

MEASURING THE VALUE OF INGREDIENT BRAND EQUITY AT MULTIPLE STAGES IN THE SUPPLY CHAIN: A COMPONENT SUPPLIER'S PERSPECTIVE

Waldemar Pfoertsch Ph.D.
CEIBS China Europe International Business School Shanghai,
China and Pforzheim University, Germany

Christian Linder Ph.D.
Faculty of Business and Law,
Pforzheim University, Germany

Jennifer D. Chandler Ph.D.
Department of Marketing,
Shidler College of Business,
University of Hawaii at Manoa, USA

Abstract

The goal of this article is to conceptualize the Ingredient Branding strategy and propose tools for measuring value derived from brand equity at the component supplier's perspective. We demonstrate how brand equity occurs and how it can be measured at three marketing stages: B2B, B2C and B2B2C. This paper characterizes different stages in the Ingredient Branding strategy. Furthermore, the paper provides a different measurement method for each stage, and highlights in the end, an overall view of all participants in the Ingredient Branding value chain.

We show first that measuring brand equity at the end user stage alone is not as useful as measuring brand equity at multiple stages of the value chain. The complexity associated with an Ingredient Branding strategy makes it a multi-stage branding and marketing effort. Therefore, various data and measurement tools are needed to meet the needs of marketing managers and scholars focused on brand strategies for differing stages of the value chain. We demonstrate that existing brand measurement methods can be modified to analyze multi-stage, interrelated exchanges.

The paper extends existing brand measurements to capture the value of an Ingredient Brand both qualitatively and quantitatively, at multiple stages of the value chain.

Keywords: Ingredient Branding, brand measurement, value chain

Paper type: Conceptual

Introduction

In today's fast-changing markets, Ingredient Branding is becoming a major marketing strategy as demonstrated by the increasing number of products sold with embedded branded components (Prince and Davies 2002; Cooke and Ryan 2000; Washburn, Till, and Priluck 2004). Despite its success in generating positive effects on participants in the value chain (for examples see Kotler and Pfoertsch 2006), the effects of Ingredient Branding in business markets has been generally overlooked in terms of brand equity (Desai and Keller 2002; McCarthy and Norris 1999; Norris 1992; Rao, Qu, and Ruekert 1999; Venkatesh and Mahajan 1997; Havenstein 2004; Pfoertsch and Mueller 2006; Kotler and Pfoertsch 2006). This work aims to shed light on understanding Ingredient Branding strategies, and suggests valuation tools for assessing brand equity from the component supplier's perspective.

The purpose of this paper is to introduce measurement instruments that enable managers to determine that value of Ingredient Brand equity at various stages of the value chain, a practice that should be beneficial for both B2B and B2C managers and scholars (Erevelles et al. 2007; Mudambi 2002; Gregory and Sexton 2007; Beverland, Napoli and Lindgreen 2007; Webster and Keller 2004; Lynch and de Chernatony 2004; Anderson and Narus 2004; Kotler and Keller 2006). The benefits of understanding and measuring value derived from Ingredient Brand equity at various stages of the value stems from the ability of high equity brands to generate opportunities for successful extensions, resilience against competitors' promotional pressures, and barriers to competitive entry (Aaker 1991, 1992; Kotler and Keller 2006; Farquhar 1989). It is not known however whether companies that rank high in brand equity – such as Intel, Tetra Park, Shimano or Dolby - (Interbrand 2006) derive value from brand equity at the original equipment manufacturer (OEM) stage, at the consumer stage, or at both stages. Traditional measures and values of brand equity focus only on next-down dyadic stages in the value creation process.

In this study, we build on the notion that component suppliers are typically Business-to-Business (B2B) companies with an OEM as a consumer brand extension. We assert that Ingredient Branding is a much more complex strategy than the strategy that most would think a B2B branding should be. This complexity requires component suppliers, as well as other firms in the value chain, to gather in-depth information from the various participants of the value chain as well as from the final customer for managing and responding to this strategy appropriately. To address these managerial needs, we extend existing marketing theory by demonstrating the

need for a more complex measurement tool that accounts for brand equity as it affects interactions across multiple stages in a value chain.

The remainder of this paper proceeds as follows: First, an overview of existing Ingredient Branding research is presented. Then, stages that are important to an Ingredient Branding strategy are defined and described. Next, measurement instruments are proposed to evaluate success at each of these stages. This leads to the assertion that fruitful stages for Ingredient Branding strategies include the B2B dyadic relationships between the component supplier and the OEM, the B2C stage between the OEM and the end user, and the B2B2C stage representing traditional communications for Ingredient Branding between component supplier and end user. We outline conclusions and provide an outlook for further research.

Ingredient Branding

Ingredient Branding is a particular type of alliance between two products, based on both firms' cooperation in designing and delivering the product, with particular emphasis on consumer recognition and identification of components in the final product (Pfoertsch and Mueller 2006). In other words, Ingredient Branding can be conceptualized as a B2B branding strategy between a manufacturer and a supplier in which the end product of the supplier becomes one of the aspects of the manufacturer's strategic concept (Ervelles et al. 2007). Ingredient Branding occurs when a branded elementary product or service is embedded within an end product that is promoted to the final user.

The motivation behind Ingredient Branding revolves around the ingredient, or component, forming an alliance with a product manufacturer in an effort to create brand awareness for the Ingredient Brand to generate pull effects with the final consumer through the value chain (Pfoertsch and Mueller 2006; Havenstein 2004). The push and pull concept is crucial to understanding Ingredient Branding and the motivations behind it. The push strategy involves directing the marketing strategy toward the original equipment manufacturers. A pull strategy involves appealing directly to the consumer. One implication of this view is that the marketing mix for an Ingredient Branding strategy involves both push and pulls effects: Consumer behavior creates pull and manufacturer behavior creates push. To demonstrate, consider push and pull effects as effects of marketing mix decisions. Supporting pull with push increases the probability of coordination. The combination of the push and pull creates synergy for the complete marketing mix. The supplier offers a component or service to his customer, the OEM. Thus, the supplier has a B2B relationship with the producers of such products as automobiles and electronic products. The OEM produces a product that is to be used by their customer, the final user. The final user

buys the product or service in a pure B2C relationship with the OEM. According to this principle, there are two separate stages of customer relationships: supplier with OEM, OEM with final user (see Fig. 1). In Ingredient Branding, the two stages are related in the following way: Step (2) follows step (1), and step (3) occurs when the supplier informs the final user that a particular ingredient is part of the final product offering and the final user chooses this product over competitive offerings. In step (4), the final customer “pulls” the product because the particular ingredient component is desired. This is a continuous process of push and pull with a high success rate if done appropriately (Luczak et al. 2007).

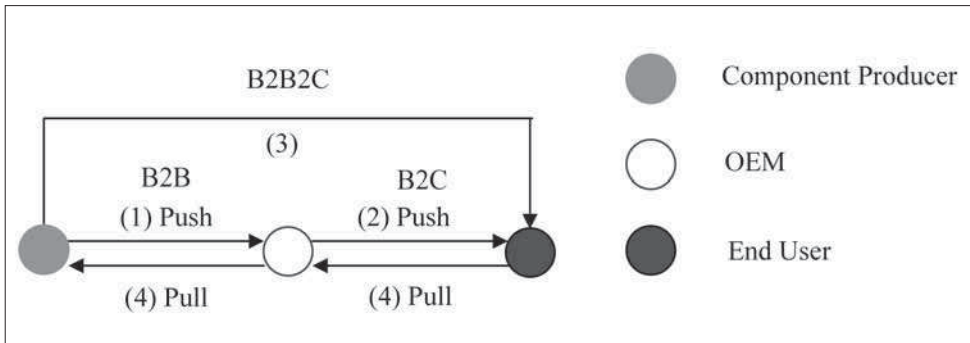

Fig. 1: *The Ingredient Brand Framework*

The notion of Ingredient Branding (Pfoertsch and Mueller 2006) is one of many brand strategies (McCarthy and Norris 1999; Norris 1992) articulated in marketing (for a summary, see Bengtsson 2002; Kotler and Pfoertsch 2006). In recent years however, its prominence and importance have increased dramatically. Examples of Ingredient Branding campaigns include “Makrolon, the High-Tech Polycarbonate“ or “100% Cotton”, which are campaigns to create brand awareness about ingredients – in this case computer chips or materials – that are contained within final consumer products. Ultimately, ingredient popularity among consumers drives demand for products and/or services that contain the branded ingredient. It has been argued that this demand then influences firms in the middle of the value chain to use these ingredients in their products or services. As a result, Ingredient Brands have been known to change the way that firms interact in the value chain (Anderson and Narus 2004; Luczak et al. 2007).

Marketing literature is inundated with studies investigating how Ingredient Brands function at the consumer level (Desai and Keller 2002; McCarthy and Norris 1999; Norris 1992; Rao, Qu, and Ruekert 1999; Venkatesh and Mahajan 1997). Why this branding strategy has positive effects has been shown in several other empirical studies (Erevelles et al. 2007; Rao and Ruekert 1994; Park, Jun, and Shocker

1996). Generally speaking, manufacturers and suppliers benefit through mutual cooperation, endorsement of each other's offerings, shared knowledge and capabilities, risk sharing, trust and shared experience. Often, an identified advantage of Ingredient Branding for component suppliers may be reducing ease of entry of competitors (Pfoertsch and Mueller 2006; Havenstein 2004; Erevelles et al. 2007). On the other side, manufacturers may enjoy a jointly enhanced market reputation. In return for the reduced probability of potential competitive entry, suppliers may reward manufacturers with a lower price. In turn, suppliers may lower costs through having a stable, long-term customer and through economies of scale (Bengtsson and Servais 2005). Another advantage focuses on the cost of the branded B2B offering which can potentially be lower due to the elimination of double marginalization resulting in lower prices for the customer. As seen in the case of Intel advertising support (Kotler and Pfoertsch 2006) the supplier helps in the marketing of the product by the manufacturer. In some cases, cash-based advertising support from the supplier to the manufacturer is passed on to the buyer in the form of lower prices (Pfoertsch and Mueller 2006). Furthermore, Ingredient Branding has been used to maximize utilization of an organization's brand assets, generate new revenues, enter new markets, create barriers to entry from competitors, share costs and risks, increase profit margins, and widen current markets (Rao and Ruekert 1994; Park, Jun and Shocker 1996).

All these advantages capture the brand value of Ingredient Branding (Aaker 1991). Among other things, this brand value can be expressed in monetary value. Existing brand literature offers various measurements of brand equity, as discussed in the following section.

Measuring Ingredient Brand Equity: An Overview

Ingredient Branding is said to have started in the chemical industry (e.g. DOW Chemical with Styron, BASF with Luran). It is possible that the first application may have occurred in the early 60's when target products were plastics and synthetic fibers. Initial scholarly studies of Ingredient Branding followed within the next few years (Corey 1962; Bergler 1963, 1968; Hertzberg 1963; Schmitt 1969; Koelbel and Schulze 1970). Marketing slogans such as "Made of Owens-Corning Fiberglas" or carpets with Stainmaster's "Always stylish, always beautiful" originated in this period.

At this time, branding strategy was defined either as an "exception" from an attribute-oriented branding strategy (Sellert 1927; Etmer 1959; Kainz 1961; Pentzlin 1973) or as an "exception" from a reaction-oriented branding strategy (Berkoven 1961; Thurmann 1961). Norris (1992) provides the initial definition that is still used today (Baumgarth 1997; Smit 1999; Freter and Baumgarth 2005; Kleinaltenkamp 2001; Havenstein 2004; Unger-Firnhaber 1996; Wiezorek and Wallinger

1997; Baumgarth 1998; Kemper 2000). Most works about Ingredient Branding are theoretical-descriptive (Simon and Sebastian 1995; Bugdahl 1996; Freter and Baumgarth 1996; Kemper 1997; Esch and Stein 2001), and empirical-quantitative studies are scarce (Havenstein 2004; Saunders and Watt 1979; Vaidyanathan and Brown 1997; Venkatesh and Mahajan 1997; Baumgarth 1998; Simonin and Ruth 1998; McCarthy and Norris 1999; Janiszewski and Van Osselaer 2000; Janiszewski, Kwee and Meyvis 2001; Van Osselaer and Janiszewski 2001; Desai and Keller 2002).

Outcomes of Ingredient Branding research have generally supported success of Ingredient Branding strategies. U.S.-based research focuses on food components such as Chiquita Bananas in infant food or Heath candy bars in ice cream. In European research, there is a focus on chemical products and technically oriented components. Examples from the automotive industry are the center of attraction.

A short characterization of research on Ingredient Branding research can be summarized with the following four attributes:

- Concentration only on select and specific questions (industry-specific)
- Out of touch with reality and factious brand and product offerings
- Limited validity due to the use of primarily university students as participants
- Research primarily concentrated on consumptive commodities (e.g. food)

Most studies focus on success and risk factors. Most include empirical analysis of products with branded ingredients compared to identical products without branded ingredients. Often, primary data utilizing survey and questionnaire data are collected (e.g. conjoint analysis) (McCarthy and Norris 1999; Havenstein 2004). Sometimes, case studies or expert interviews are used (Kotler and Pfoertsch 2006; Pfoertsch and Mueller 2006). More recently, aspects of the Service-Ingredient-Branding framework are assessed (Burmam and Weer 2007; Bruhn 2007). It should be noted that services as brand relevant components of total performance are of particular interest. Of the existing studies, however, most overlook an explicit differentiation between B2C oriented vs. B2B oriented ingredient branding strategies.

Relevant stages for measuring the value of Ingredient Brands

As seen in Fig. 1, the component supplier offers a product to the OEM (B2B). The OEM uses the component to produce the end product and sells the end product to the end user (B2C). At the same time, the component supplier communicates advantages of the component for an end product to the end user (B2B2C). It is critical that Ingredient Brand valuation captures the pull effect, resulting from the end user preference in this scenario. Most studies often focus solely on the OEM/end user stage and, as a result, success from the perspective of the component supplier at the

B2B stage is overlooked. To appropriately allocate value to an Ingredient Branding strategy, it is necessary to include the network of all up-stream markets, beginning with the component supplier and culminating with the end customers. By taking this approach, it becomes necessary to broaden the analysis of exchange beyond dyads and include those exchanges that occur within larger networks of firms. In marketing, these sets of firms have been referred to as distribution channels, value chains, embedded markets, network markets, or, simply, networks (Coughlan et al. 2001; Vargo and Lusch 2004; Wathne, Biong and Heide 2001; Frels, Shervani and Srivastava 2003; Wilkinson 2001). The key to this perspective is that the firms are inter-related because they are all involved in bundling ingredients into final products or services for consumption by an end consumer (Coughlan et al. 2001), and exchange in one dyad is affected by exchange in another dyad (Money, Gilly and Graham 1998; Wuyts, Stremersch, and Van Den Bulte 2004). This notion of interrelatedness has been the center of many studies (Wathne and Heide 2004; Achrol, Reve and Stern 1983; Bagozzi 1975).

Measuring Ingredient Brand Equity at Multiple Stages

As mentioned above, at the B2B stage, brand equity provides value for the component supplier at the supplier-OEM stage (Mudambi 2002; Beverland, Napoli and Lindgreen 2007; Webster and Keller, 2004; Lynch and de Chernatony 2004; Anderson and Narus 2004; Kotler and Keller 2006). Value at the B2B stage is heightened when there is extraneous support from a consumer pull effect (because customers will demand end products containing the branded component). When an OEM demands the branded component in response to consumer pull effects, the final step of a *successful* Ingredient Branding strategy is achieved. Because this stage represents the point where component suppliers (who have initiated the Ingredient Brand strategy) can reap the most economic benefits, it is recommended that the measurement of brand equity be isolated at this stage.

Brand equity is derived from customer willingness to pay a price premium for a branded product when compared to the price of an identical unbranded product (Subrahmanyam 2004). The price premium, as a result of brand equity, becomes a source of value for the firm (Aaker 1991, 2003; Kotler and Pfoertsch 2006; Sattler 2001). As a result, the component supplier is able to ask for higher prices with a branded component compared with an identical component that is not branded. Conversely, it may sometimes be the case that increased sales of a component improves brand equity. In these situations, brand building is seen as an investment and increases in marketing expenditures, communication costs and other brand building activities should generate increased prices and/or sales (Sattler 1997). Based on previous

studies, we define “revenue-premium” as the price premium (P_B) multiplied by sales premium (S_B) (Ailawadi, Lehmann and Neslin 2003).

The combination of price premium and sales premium can be beneficial in four ways (Fig. 3). In the best case scenario (Case A in Fig. 3), the component supplier achieves a price premium (where P_B = price of branded product and P_{unB} = price of unbranded product) as well as a sales premium (S_B = sales of branded product, S_{unB} = sales of unbranded product). In Case B, P_B is higher than P_{unB} but at the same time S_B is lower S_{unB} . The benefit for the component supplier in this case is the difference between the positive effect of P_B (+) and the negative effect of S_B (-). In case C, S_B are higher than S_{unB} but at a lower price level. In the worst case scenario (Case D), there are both lower prices and lower sales of the branded component compared to an identical component without a brand.

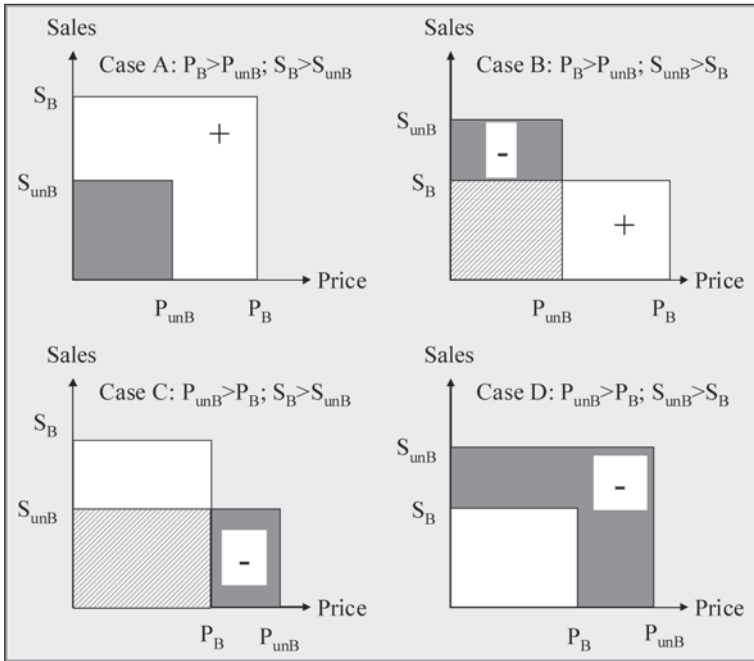

Fig. 2: Possible constellation for price and sales premium

Data to measure price and sales premium are typically available from most companies via panel data. Another way to collect data is on the basis of individual survey and/or interview. Often, self-explicated models or conjoint analyses are used to find out the willingness to pay for a special branded product compared to an unbranded one (Sattler 2001, Havenstein 2004).

Understanding where value resides for OEMs in an Ingredient Brand Strategy

OEMs pursue various goals when labeling components in their products. Differentiation from competitors (Kotler and Pfoertsch 2006; Venkatesh and Mahajan 1997), security from substitution (Norris 1992), realization of price premiums (Rao, Qu, and Ruekert 1999; Kotler and Pfoertsch 2007), reduction of marketing costs (Bengtsson and Servais 2005) or production / research / development costs (Erevelles et al. 2007) are only a few possible advantages.

However, these various advantages stem from the same source: consumer preference for an end product that contains the branded component (Rao and Ruekert 1994; Park, Jun and Shocker 1996). Extending these results, we argue that this preference becomes salient when consumers are asked to express their preference for an end product with a branded component versus an end product without the same branded component (fig.3).



Fig. 3: *Qualitative value of Ingredient Branding from the OEM point of view.*

Value in the supplier-OEM dyad is of a qualitative nature because value in business-to-business markets such as these often manifests as “softer” factors such as awareness, trust, brand association or recognized quality (Aaker 1991; Srivastava and Shocker 1991; Kotler and Keller 2006). This is difficult to understand until it is recognized that the OEM derives “softer” value and the supplier can deliver “softer” value because of where the OEM is positioned in the value chain. Specifically, the OEM sits between the component supplier and the end user. In this way, the OEM must manage both sets of relationships. As described above, the OEM derives financially-based value from its end user customers, but in order to efficiently manage its supplier relationships and focus on its end user customers, it must be able to rely and depend on its suppliers. In other words, the OEM derives relationally-oriented value from its component supplier. This relationally-oriented value assists the OEM in attaining the price premiums derived from Ingredient Brand equity at the OEM-end user stage. Component suppliers indirectly derive value from end-user Ingredient Brand equity in other ways, such as, for example, increasing market power, increasing barriers to entry, shortening length of value chain, and improving brand position, among others. These have all been shown to positively influence willingness of a component supplier to initiate an Ingredient Brand strategy (Luczak et al. 2007).

Traditional Concepts of B2C Brand Equity

To measure brand equity at the B2C level, we build on four influencing factors of the brand. Aaker (1991, 1992) suggests an all-encompassing measurement of brand value. We modify these to determine the advantages of carrying an end product with a branded ingredient. According to Aaker (1991), brand loyalty, trust, brand association and the recognized quality are factors which build brand value (Fig. 4). Each of these is detailed below.

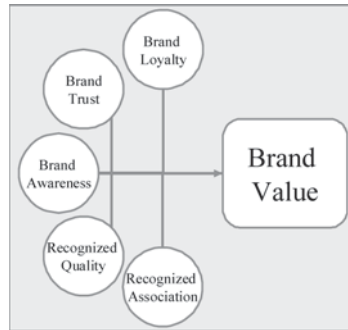

Fig. 4: *Qualitative influence factors of the brand value.*

Brand loyalty

Customer loyalty has been a major focus of strategic marketing planning (Kotler and Keller 2006) and offers an important basis for developing a sustainable competitive advantage (Dick and Basu 1994). The definition of brand loyalty by Jacoby and Chestnut (1978) is still used today (e.g., Bandyopadhyay, Gupta and Dube 2005; Quester and Lim 2003; Schoenbachler, Gordon and Aurand 2004). In their definition, Jacoby and Chestnut (1978) discuss brand loyalty as being “(1) biased (i.e., non-random), (2) behavioral response (i.e., purchase), (3) expressed over time, (4) by some decision-making unit, (5) with respect to one or more brands out of a set of such brands, and is a function of psychological (decision-making, evaluative) processes” (1978, p. 2). Despite a multitude of definitions and measurements of brand loyalty (Baldinger and Rubinson 1996; Chaudhuri 1995; Barwise and Ehrenberg 1987; Dick and Basu 1994; Kahn, Kalwani and Morrison 1986), brand loyalty generally entails a strong commitment to a particular brand on the part of the consumer. Brand loyalty is thought to be an imported concept of marketing practitioners for a number of reasons (Rundel-Thiele and Macky 2001). Dick and Basu (1994) suggest that brand loyalty favors positive word of mouth and greater resistance among loyal customers to competitive strategies. It is widely considered that loyalty is one of the ways with which consumers express his/her satisfaction with the performance of the product or service received (Kahn, Kalwani and Morrison 1986; Delgado-Ballester

and Munuera-Aleman 2000; Bloemer and Kasper 1995). Loyal consumers, compared to non-loyal consumers, will work harder to obtain that brand on each occasion, possibly by paying more attention to marketing activities such as advertising and promotion (Bandyopadhyay, Gupta and Dube 2005). However, brand loyalty is a key determinant of brand choice and brand equity (Schoenbachler, Gordon and Aurand 2004). Aaker notes that the brand loyalty of the customer base is often the core of a brand's equity (1991). If customers are indifferent to the brand and will buy with respect to features, price, etc., there is likely little equity. One big advantage of high loyal customer can be found in lower cost of holding customers than the cost of building relationships to new customers (Mussler and Mussler 1995). Brand loyalty can be measured by real customer behavior, their individual performance rating, the customers' satisfaction with product and the sympathy for the brand (Aaker 1991; Kahn, Kalwani and Morrison 1986).

Trust

Brand trust builds the core of brand value (Aaker 1991). Trust evolves from past experience and prior interaction (Garbarino and Johnson 1999) because its development is portrayed most often as an individual's experiential process of learning over time (Delgado-Ballester and Munuera-Alemán 2005). People trust a business based on their own past experience as well as by third party recommendations (Reast 2004). Seen as multidimensional in the majority of marketing studies (Raimondo 2000), trust is reported to be: involved, as part of "brand credibility", in brand extension acceptance (Keller and Aaker 1992); fundamental to the development of loyalty (Berry 1993; Reicheld and Schefter 2000); as critical in maintaining successful agency-client relationships (Labahn and Kohli 1997); as a component of brand equity (Dyson et al. 1996); and as essential in building strong customer relationships on the internet (Urban et al. 2000), and "perhaps the single most powerful relationship marketing tool available to a company" (Berry 1995). The impact of brand trust on brand value is manifold. To name only a few, the lower costs of communicating to trusting consumers instead of new ones, the reduced risk for future incomes and increased residual value as an effect of long-term brand effects because of consumers brand trust (Mussler and Mussler 1995; Jenner 2005; Aaker 1991). More, a trusting consumer base is a strong argument for listing trails with retailer. Furthermore, only the existence of loyal consumer increases the awareness of the brand (Kotler and Pfoertsch 2006). Trust is not easy to measure. It can be calculated by exploring the de facto customer behavior. The estimation of consumer satisfaction and affection to a brand can also be used as an indicator for brand trust (Aaker 1991).

Brand awareness

Brand awareness is defined as the ability of possible consumers to remember that a special brand belongs to a special product (Aaker 1991). Based on that we can separate, there are several levels of brand awareness depending on the ease with which a consumer can recall the brand. Aided recall is insufficient to generate a consumer choice by itself, since the consumer is unable to generate a picture of the brand. The associative memory model would describe the strength of association between the brand and the situation as relatively weak. However, since the consumer can recognize the brand when confronted by it, marketing efforts may still have a positive effect (Bekmeier-Feuerhahn 1998). If consumers make decisions in the store for a group of products, recognition will be very important in shaping the purchase of those products (Pitta and Katsanis 2004). For measuring the brand value for the ingredient, another dimension is necessary. Customers need to recognize the branded component without the host product. They must notice the Ingredient Brand as a special component with a special benefit for the whole product. This benefit must be linked to the component or in other words to the Ingredient Brand Positively identified with an end product, the Ingredient Brand can have positive effects on the recognition as well as the assumption about the adopted quality. Methods to measure the brand awareness are recall-test and recognition test to find out the strength of awareness (Esch and Geus 2001)

Recognized quality

The recognized quality of a product or the ingredient is understood as the customer's assumption about the quality of product function compared to another product (Aaker 1991). At first, recognized quality is an estimation about a product in the eyes of the consumer. Therefore, it can differ from the real quality of a product. We have to consider that the recognized quality of the end product can either be lower in consideration of the branded component as well as higher when first evaluated by the consumer. (Pfoertsch and Mueller 2006; Kotler and Pfoertsch 2006). This factor is the answer to an important question for the OEM: Does the Ingredient Brand enhance the recognized quality of the end product or is my product devaluated by a weaker brand? To measure this, a conjoint analysis or scanner data for the separation of the consumer preferences are used (Srivastava and Stocker 1991).

Brand association

Aaker (1991) asserted that the underlying value of a brand name often is the set of associations, its meaning for the people. Associations represent the basic for purchase decisions and for brand loyalty (Chen 2001). Keller (1993) defined brand associations as the other informational nodes linked to the brand node in memory

and contained the meaning of the brand for consumers. Consumer-derived brand meanings are, in part, conveyed in the associations they make with the brand itself (Aaker 1990; Keller 1993); and the associations also provide cues for information retrieval (Tybout et al. 1981; Janiszewski and Van Osselaer 2000; Van Osselaer and Janiszewski 2001). Strong, positive associations help to strengthen brands and the equity that is carried into a leverage situation is affected by the types of associations made with the brand (Park et al. 1991; Keller 1991; Kirmani et al. 1999; Bridges et al. 2000). Brand associations are anything about the likeability of a brand (Aaker, 1990; Keller 1993), and help in the formation of the brand's image (Biel 1991). Brand image consists of the attributes and associations that consumers connect to a brand, they can be "hard", specific tangible, functional attributes of the brand, or "soft", emotional-based attributes of the brand such as trustworthiness or dullness (Biel 1991; Keller 1993). With the help of brand image, products can be differentiated from those of competitors even when the other product is physically 100% identical (Schlagberg 1997). Associations can be measured indirectly as well as directly. The direct questioning of consumers is relatively easy (Bekmeier-Feuerhahn 1998). However, an indirect approach is needed if it's expected that the consumer won't speak clearly and openly about his feelings and attitude (Esch and Andresen 1997).

Measuring the Ingredient Brand effect on the Business-to-Consumer stage

Measurement at the B2C stage is based on Aaker's (1991) brand valuation model. The categories described above are used to illustrate the end consumer's brand understanding. The result is a qualitative brand profile that is as unique as each brand. Each category is operationalized for measuring the brand value from the consumer's perspective. The relativity of a concept such as "trust" is quite evident when considering its meaning across categories such as automotive, durable, or perishable products; explication of the meaning of "trust" should involve methodology that allows for such variations.

In order to further clarify this approach, let us consider "recognized quality". As demonstrated in previous studies, recognized quality is an important aspect to consider particularly in Ingredient Branding because it is often assumed that brands associated with high quality components have positive effects on the whole end product (Havenstein 2004; McCarthy and Norris 1999). With this approach the OEM can determine whether an Ingredient Brand improves the whole recognized quality of an end product. If such positive effects exist, it is worthwhile to position an end product competitively by displaying the Ingredient Brand logo on the end product. This approach enables managers to utilize qualitative studies effectively, and for scholars of Ingredient Branding to generate a richer understanding of the phenomenon.

To demonstrate, a series of interviews were conducted that asked for opinions of child toys with and without antibacterial protection. The end products were identical, but one of them conveyed the logo of a prominent antibacterial protection plastic. The goal was to determine the effect of an Ingredient Brand on the end product (i.e., child toy). Questions were formulated that centered on notions of child security and play toys. This was done for similar end products that either contained the Ingredient Brand or did not contain the Ingredient Brand. Respondents were instructed to respond on a 7-point scale (0 being respondent associates the end product with security and 7 being respondent does not associate the end product with security). And, responses were collected for both end products. By collecting data that measures perception of the end products WITHOUT the ingredient brand, as well as perception of end products WITH the ingredient brand, it is possible to generate two sets of data. A brand profile, as an example, is shown in fig. 5.

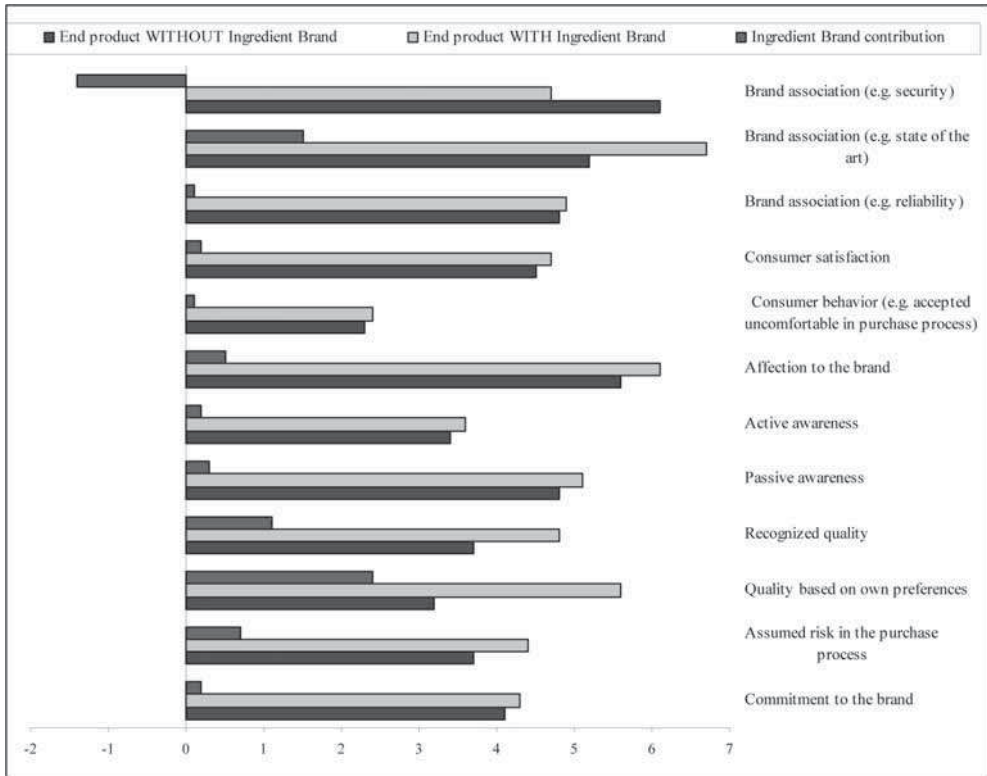

Fig. 5: *Quantitative brand value profile with and without the Ingredient Brand*

First, the black bar represents responses for end products WITHOUT the ingredient brand, while the gray bar represents responses for end products WITH the ingredient brand (Aaker 1991). Looking at these two bars in combination thereby demonstrates the contribution that an Ingredient Brand makes to the end product. The red bar demonstrates a third type of insight about the Ingredient Brand that is relevant for an OEM when deciding whether to initiate this strategy for an end product. More specifically, the red bar is the difference between the black and the gray bar, and it represents which aspects are improved by utilizing the ingredient brand and conveying its use in marketing efforts. It is necessary to keep in mind that this profile is particularly useful for situations with established Ingredient Brands.

Ingredient Branding and the B2B2C chain

In the B2B2C chain, both the component supplier and the end user are involved, and they each represent endpoints of the chain. An important assumption of Ingredient Branding in the B2B2C chain is that the component supplier undertakes the effort to communicate the benefits of a branded ingredient to the end user using instruments of the marketing mix (Kotler and Pfoertsch 2006; Luczak et al. 2007).

To determine the success of B2B2C marketing activities, Havenstein (2004) recommends using the willingness to pay price premiums. However, most component suppliers implement an Ingredient Branding strategy expecting many advantages, including reducing the anonymity of a component, differentiating components from other competitors, and generating pull effects through the value chain by generating end user preference for the branded ingredient (Pfoertsch and Mueller 2006). Measuring success on all these dimensions is difficult.

For this reason, it is recommended that “end user willingness to pay a price premium for an end product with the branded ingredient” is useful as a single index of success for the following reasons. First, it demonstrates that end users are aware of the component brand because they would not otherwise be willing to pay the price premium. Second, it demonstrates that end users are able to differentiate among competing component suppliers. More important, it demonstrates end users’ ability to recall positive associations with the Ingredient Brand and use this recall to the benefit of the whole end product. Third, it demonstrates the positive accrual of a pull effect (From this point of view, a sales premium can also be seen as a price premium, instead of a higher sales, price can be increased.). Extending the analysis to a broader realm of the B2B2C chain sheds light on otherwise “invisible” mechanisms in Ingredient Branding strategies. For example, analysis of the OEM-end user stage as extracted from the B2B2C chain makes it difficult to isolate determinants of why the OEM embedded the branded component in its end product offering to the

end user. However, investigating the end user's willingness to pay a price premium, along with the other mechanisms in the B2B2C chain does not constrain analysis to the OEM's procurement decisions. Instead, the analysis focuses on the motivations of the OEM to use the branded ingredient in an end product.

There are a wide range of instruments to measure willingness to pay for an end product embedded with an Ingredient Brand. The most prominent and well-established method is conjoint analysis because it can be used to discover and compare varying attributes and sub-benefits. One of these sub-benefits may be the Ingredient Brand (Havenstein 2004; Sattler 1997). As demonstrated above, it is a strong, attainable, and rigorous determinant of Ingredient Branding success.

Conclusion and perspectives for further development

This paper demonstrates the complex structure of an Ingredient Branding strategy by explicating how a branded component affects the multiple stages of exchange that exist among a component supplier, OEM, and end user. Giving attention to this network from the perspective of the component supplier allows an exploration of value that can be harnessed from the supplier's point of view. Building on existing marketing theory, this paper demonstrates that many questions remain unanswered and also demonstrates that the mechanisms of Ingredient Branding operate differently at each stage of the network. And, as a result, it highlights that assessing Ingredient Branding effects at multiple stages of the B2B2C chain requires varying types of measurement tools, data collection methods, and analysis techniques. These requirements demonstrate, on one hand, that each stage of Ingredient Branding requires various – perhaps contrasting – approaches to building brand equity at each stage (B2B vs. B2C and B2B2C branding). On the other hand, these requirements demonstrate that the component supplier's position and perspective relative to brand strategies are important in driving relevant, useful, and competitive brand and marketing theories.

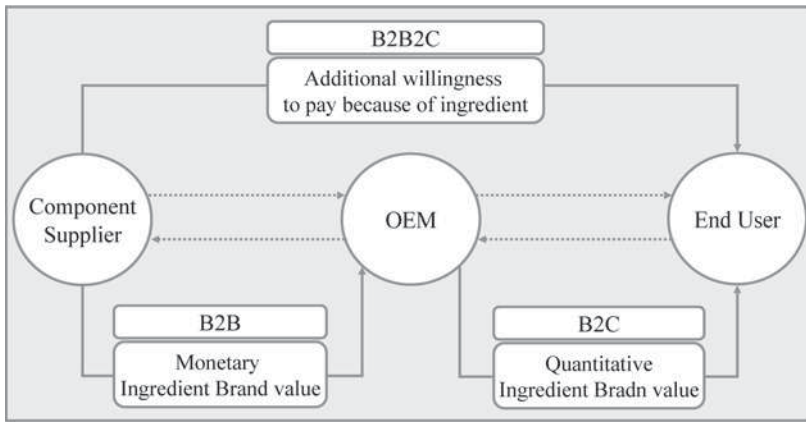

Fig. 6: *Measurement methods on the characteristic stages of Ingredient Branding*

In summary, the value of brand equity at each stage of the value chain should be considered independently and in combination with the other stages. Instruments for measuring Ingredient branding success at multiple stages are summarized below, and also in Figure 4.

- **B2B Stage:** The level between the component supplier and the OEM is the most important point at which the component supplier can generate financial benefits. Here, a successful Ingredient Branding strategy reaps the benefits of a pull effect from the end user that drives the OEM to prefer the branded component over an unbranded one. Therefore, at this stage, it is recommended that a financially-oriented measurement tool based on price premiums be used.

- **B2C Stage:** From the perspective of a component supplier, the end user is distant and often out of immediate reach. However, Ingredient Branding is most successful when it can be fruitful at all levels of the B2B2C chain. In the B2C (or OEM-end user) stage, it is recommended that success be evaluated with a quantitative method from the perspective of the OEM.

- **B2B2C Stage:** Analysis of the B2B2C chain is also quantitative, and is based specifically on end user willingness to pay a price premium. For several reasons (such as Ingredient Brand awareness, differentiation, consumer's connection of positive brand understanding and initial point for pull effects), end user willingness to pay a price premium signifies successful branding efforts from the perspective of the end user.

Literature

- Aaker, D. A. (1991), *Managing Brand Equity*, The Free Press, New York.
- Aaker, D. A. (1992), "Value of brand equity," *Journal of Business Strategy*, 13(4), pp. 27-33.
- Aaker, D. A. (2003), "The Power of the branded differentiator," *MIT Sloan Management Review*, 45(1), pp. 83-87.
- Aaker, D.A. (1990), "Brand extensions: the good, the bad, and the ugly," *MIT Sloan Management Review*, (Summer), pp.47-56.
- Achrol, R. S., T. Reve and L. W. Stern (1983), "The Environment of Marketing Channel Dyads - a Framework for Comparative-Analysis," *Journal of Marketing*, 47 (4), pp. 55-67.
- Ailawadi, K. L., D. R. Lehmann and S. A. Neslin (2003), "Revenue premium as an outcome measure of brand equity," *Journal of Marketing*, 67, pp. 1-17.
- Anderson, J.C. and J.A Narus. (2004), *Business market management: Understanding, Creating, and Delivering Value*, 2nd ed., Pearson Prentice Hall: New Jersey.
- Bagozzi, R. P. (1975), "Marketing as Exchange," *Journal of Marketing*, 39 (4), pp. 32-39.
- Baldinger, A. L. and J. Rubinson (1996), "Brand loyalty: the link between attitude and behaviour," *Journal of Advertising Research*, 36 (6), pp. 22-34.
- Bandyopadhyay, S, K. Gupta and L. Dube (2005), "Does brand loyalty influence double jeopardy? A theoretical and empirical study," *Journal of Product & Brand Management*, 14 (7), pp. 414-423.
- Barwise, T.P. and A.S.C. Ehrenberg (1985), "Consumer beliefs and brand usage," *Journal of the Market Research Society*, 27 (2), pp. 81-93.
- Baumgarth, C. (1997), *Ingredient Branding – Begriffe, State of the Art & Empirische Ergebnisse*, Working Paper, Chair of Marketing, University of Siegen: Siegen.
- Baumgarth, C. (1998), *Ingredient Branding – Markenpolitik für Produktionsgüter*, in: Tagungsband zur 1. Kunststoff-Marketing-Tagung, Breuer, H. and Dolfen, E. (Eds.), Willich, pp. 5-17.
- Bekmeier-Feuerhahn, S. (1998), *Marktorientierte Markenbewertung*, Wiesbaden.
- Bengtsson, A. (2002), *Consumers and Mixed-Brands: On the Polysemy of Brand Meaning, Marketing*, Stockholm, Lund University: Lund.

Bengtsson, A., and P. Servais (2005), "Co-branding on industrial markets," *Industrial Marketing Management*, 34(7), pp. 706–713.

Berekoven, L. (1961), "Markenbildung und Markenbewertung bei Produktivgütern," *Markenartikel*, 24 (10), pp. 814-820.

Bergler, G. (1963), "Durchgängige Werbung," *Der Markt*, 2, pp. 9-13.

Bergler, G. (1968), *Absatz – Materialien für eine Absatzlehre*, Nürnberg.

Berry, L. L. (1993), *Relationship marketing, in: Emerging Perspectives on Services Marketing*, Berry, L.L., Shostack, G.L., Dupah, G. (Eds.), Chicago, IL, pp.25-28.

Berry, L. L. (1995), "Relationship marketing of services. Growing interest, emerging perspectives," *Journal of Academy of Marketing Science*, 23 (4), pp. 236-245.

Beverland, M., A. Lindgreen and J. Napoli (2007), "Branding the business marketing offer: exploring brand attributes in business markets," *Journal of Business & Industrial Marketing*, 22 (6), pp. 394-399.

Biel, A.L. (1991), "The brandscape. Converting image into equity", *Admap*, (October), pp. 41-6.

Bloemer, J and H. Casper (1995), "The complex relationship between customer satisfaction and brand loyalty," *Journal of Economic Psychology*, 16 (2), pp. 311-329.

Bridges, S., L.K. Keller and S. Sood (2000), "Communication strategies for brand extensions: enhancing perceived fit by establishing explanatory links," *Journal of Advertising*, 29 (Winter), pp.1-11.

Bruhn, M. (2007), *Ingredient Branding bei Dienstleistungen*, in, *Ingredient Branding*, Mattmüller, R., Bernd M. and Tunder, R. M. (Eds.), Munich, Forthcoming 2008.

Bugdahl, V. (1996), "Ingredient Branding – eine Markenstrategie für mehrere Nutznießer," *Markenartikel*, 3, pp. 110-113

Burmann, C. and P. Weer (2007), *Ingredient Branding bei investiven Dienstleistungen – Das Beispiel Lufthansa Cargo*, in, *Ingredient Branding*, Mattmüller, R., Bernd M. and Tunder, R. M. (Eds.), Munich, Forthcoming 2008.

Chaudhuri, A. (1995), "Brand equity or double jeopardy?," *Journal of Product & Brand Management*, 4 (1), pp. 26-32.

Chen, A. (2001), "Using free association to examine the relationship between the characteristics of brand associations and brand equity," *Journal of Product & Brand Management*, 10 (7), pp. 439-451.

- Cooke, S., and P. Ryan (2000), "Brand alliances: From reputation to collaboration on core competencies," *Irish Marketing Review*, 13 (2), pp. 36–41.
- Corey, R. (1962), *Industrial Marketing*, Engelwood Cliffs: New York.
- Coughlan, A., E. Anderson, L.W. Stern and A. El-Ansary (2001), *Marketing Channels*, 6th ed. Upper Saddle River, New Jersey: Prentice Hall.
- Delgado-Ballester, E. and J.L. Munuera-Aleman (2000), "Brand trust in context of consumer loyalty," *European Journal of Marketing*, 35 (11 and 12), pp. 1238-1258.
- Dennis A. P. and L. P. Katsanis (2004), "Understanding brand equity for successful brand extension," *Journal of Consumer Marketing*, 12 (4), pp. 51-64.
- Desai, K. K. and K.L. Keller (2002), "The effects of ingredient branding strategies on host brand extendibility," *Journal of Marketing*, 66 (1), 73-93.
- Dick, A.S. and K. Basu. (1994), "Customer loyalty: toward an integrated conceptual framework", *Journal of Academy of Marketing Science*, 22 (2), pp. 99-113.
- Dyson, P., A. Farrand N. Hollis (1996), "Understanding, measuring, and using brand equity", *Journal of Advertising Research*, (November/December), pp. 9-21.
- Delgado-Ballester, E. and J.L. Munuera-Aleman (2005), "Does brand trust matter to brand equity?," *Journal of Product & Brand Management*, 14 (3), pp. 187-196.
- Erevelles, S., T.H. Stevenson, S. Srivivivasan and N. Fukawa. (2007), "An Analysis of B2B Ingredient Co-branding Relationships," *Industrial Marketing Management*, accepted 2007, Forthcoming.
- Esch, F.-R. and T. Andresen (1994), *Messung des Markenwerts*, in, *Marktforschung*, Tomczak, T. and Reinecke, S. (Eds.), St. Gallen, pp. 212-230.
- Esch, F.-R. and P. Geus (2001), *Ansätze zur Messung des Markenwertes*, in, *Moderne Markenführung*, Esch, F.-R. (Eds.), 3rd ed. Wiesbaden, pp. 1026–1105.
- Esch, T. and M. Stein (2001), "Ingredient Branding – Die Macht der Liferantenmarke," *Planung & Analyse*, 28 (1), pp. 64-68.
- Etmer, H. C. (1959), *Die besonderen Risiken der Markenartikelindustrie*, Munich.
- Farquhar, P.H. (1989), „Managing brand equity”, *Marketing Research*, 1, pp.24-33.
- Frels, J. K., T. Shervani, and R. K. Srivastava (2003), "The integrated networks model: Explaining resource allocations in network markets," *Journal of Marketing*, 67 (1), pp. 29-45.

Freter, H. and C. Baumgarth (1996), "Ingredient Branding - Komplexer als Konsumgüter Marketing," *Markenartikel*, 58, (10), pp. 482-489.

Freter, H. and C. Baumgarth (2005), *Ingredient Branding: Begriffe und theoretische Begründung*, in, *Moderne Markenführung*, Esch, F.-R. (Eds.), 4th ed., Wiesbaden, pp. 455-480.

Garbarino, E. and M. Johnson (1999), "The different roles of satisfaction, trust and commitment in customers relation," *Journal of Marketing*, 63 (4), pp. 70-87

Gregory, J. R. and D. E. Sexton (2007), "Hidden Wealth in B2B Brands," *Harvard Business Review*, (March), p. 23.

Havenstein, M. (2004), *Ingredient Branding - Die Wirkung der Markierung von Produktbestandteilen bei konsumtiven Gebrauchsgütern*, Wiesbaden.

Hertzberg, W. (1963), "Markenbewertung für einen Kunststoff," *Absatzwirtschaft*, 10, pp. 732-736.

Interbrand (ed.) (2006), *The best global brands 2006 – A ranking by brand value*, New York.

Jacoby, J. and , R.W. Chestnut (1978), *Brand Loyalty Measurement and Management*, John Wiley: New York,.

Janiszewski, C. and S.M.J. van Osselaer (2000), "A connectionist model of brand-quality associations," *Journal of Marketing Research*, 37 (8), pp. 331-50.

Janiszewski, C., L. Kwee and T. Meyvis (2001), *The influence of brand partners on the strength of brand associations*, Working Paper, University of Florida: Miami.

Janiszewski, C. and S. M. J van Osselaer (2000), "A Connectionist Model of Brand-Quality Associations," *Journal of Marketing Research*, 37 (1), pp. 5-20.

Jenner, T. (2005), "Anmerkungen zum Markenwert: Markenführung – Markenkontrolle - Markenwert – Realooptionen," *Die Betriebswirtschaft*, 65 (5), pp. 458-470.

Kahn, B.E., M.U. Kalwani, and D.G.Morrison (1986), "Measuring variety seeking and reinforcement behaviors using panel data", *Journal of Marketing Research*, 23(5), pp. 89-100.

Kainz, H. (1961), "Markenartikel im Produktionsbetrieb," *Markenartikel*, 23 (10), pp. 704-715.

Keller, K.L. (1991), *Conceptualizing, measuring, and managing customer-based brand equity*, Working Paper, Graduate School of Business, Stanford University: Stanford.

Keller, K.L. (1993), "Conceptualizing, measuring, and managing customer-based brand equity," *Journal of Marketing*, 57 (January), pp.1-22.

Keller, K.L. and D.A. Aaker (1992), "The effects of sequential introduction of brand extensions," *Journal of Marketing Research*, 29 (February), pp.35-50.

Kemper, A. C. (2000), *Strategische Markenpolitik im Investitionsgüterbereich*, Lohmar.

Kemper, A. K. (1997), "Ingredient Branding," *Die Betriebswirtschaft*, 57 (2), pp. 271-274.

Kirmani, A., S. Sood and S. Bridges (1999), „The ownership effect in consumer responses to brand line stretches," *Journal of Marketing*, 63 (January), pp.88-101.

Kleinaltenkamp, M. (2001), *Ingredient Branding: Markenpolitik im Business-to-Business-Geschäft*, in, Erfolgsfaktor Marke, Köhler, R., W. Majer and H. Wiezorek (Eds.), Munich, pp. 261- 270.

Koelbel, H. and J. Schulze (1970), *Der Absatz in der Chemischen Industrie*, Berlin et al.

Kotler, P. and K.L Keller. (2006), *Marketing Management*, 12th edition: New York.

Kotler, P. and W. A. Pfoertsch (2006), *B2B Brand Management*, Springer: New York.

Kotler, P. and W.A.Pfoertsch (2007), "Being Known or Being One of Many - The need for Brand Management for Business-to-Business (B2B) Companies," *Journal of Business & Industrial Marketing*, 20 (6), pp. 357-362

Labahn, D.W. and C. Kohli (1997), "Maintaining client commitment in advertising agency-client relationships," *Industrial Marketing Management*, 26 pp. 497-508.

Luczak, C., W.A. Pfoertsch, F. Beuk and J. Chandler (2007), "Ingredient branding: Development of a Conceptual Model," *Academy of Marketing Studies Journal*, 11 (2), S. 123-135.

Lynch, J. and L. de Chernatony (2004), "The power of emotion - brand communication in business to business markets," *Journal of Brand Management*, 11 (5), pp. 403-419.

McCarthy, M. S. and D.G. Norris (1999), "Improving Competitive Position using Branded Ingredients," *Journal of Product & Brand Management*, 8 (4), pp. 267-285.

Michell, P., J. King and J. Reast (2001), "Brand values related to industrial products," *Industrial Marketing Management*, 30, pp. 345-354.

Money, R. B., M. C. Gilly, and J. L. Graham (1998), "Explorations of national culture and word-of-mouth referral behavior in the purchase of industrial services in the United States and Japan," *Journal of Marketing*, 62 (4), pp. 76-87.

Mudambi, S. M. (2002), "Branding importance in business-to-business markets: Three buyer clusters," *Industrial Marketing Management*, 31 (1), pp. 525-533.

Mussler, D. and S. Mussler (1995), "Marken-Bewertung in der Praxis: Eine Zwischenbilanz – Teil 1," *Marketing Journal*, 28 (4), pp. 184-187.

Norris, D. G. (1992), "Ingredient Branding: A Strategy Option with Multiple Beneficiaries," *Journal of Consumer Marketing*, 9 (3), pp. 19-31.

Park, C. W., Jun, S. Y., and Shocker, A. D. (1996), "Composite branding alliances: An investigation of extension and feedback effects," *Journal of Marketing Research*, 33(4), pp. 453-466.

Park, C. W., S. Millberg and R. Lawson (1991), "Evaluation of brand extensions: the role of product level similarity and brand concept consistency", *Journal of Consumer Research*, 18 (September), pp. 185-193.

Pentzlin, K. (1973), *Markenartikel – Gedanken zur Begriffsbestimmung*, in, *Instrumente der Unternehmensführung*, Hax, K. and Pentzlin, K. (Eds.), Munich, pp. 80-89.

Pfoertsch, W. and I. Mueller (2006), *Marke in der Marke, Bedeutung und Macht des Ingredient Branding*, Springer: Heidelberg.

Prince, M., and M. Davies (2002), "Co-branding partners: What do they see in each other?," *Business Horizons*, 45, pp. 43-55.

Quester, P. and A. L. Lim (2003), "Product Involvement/brand loyalty: is there a link?," *Journal of Product & Brand Management*, 12(1), pp. 22-38.

Raimondo, M.A. (2000), "The measurement of trust in marketing studies: a review of models and methodologies", *IMP Conference Papers*, Bath University, Bath.

Rao, A. R., and R. W. Ruekert (1994), "Brand alliances as signals of product quality," *MIT Sloan Management Review*, 36(1), pp. 87-97.

Rao, A. R., L. Qu and R. W. Ruekert (1999), "Signaling unobservable product quality through a brand ally," *Journal of Marketing Research*, 36 (2), pp. 258-268.

Reast, J.D. (2005), "Brand trust and Brand extension acceptance: the relationship," *Journal of Product & Brand Management*, 14(1), pp. 4-13.

Reicheld, F.F. and P. Scheffer (2000), "E-loyalty: your secret weapon on the web", *Harvard Business Review*, 78 (July/August), pp.105-113.

Rundel-Thiele, S., and M.M. Mackay (2001), "Assessing the performance of brand loyalty measures," *Journal of Service Marketing*, 15(7), pp. 529-546.

Srinivasan, S. (2004), "Role of trust in e-business success," *Information Management & Computer Security* 12 (1), pp. 66-72.

Sattler, H. (1997), *Monetäre Bewertung von Markenstrategien für neue Produkte*, Stuttgart.

Sattler, H. (2001), *Markenpolitik*, Stuttgart.

Saunders, J. and A. Watt (1979), "Do brand names differentiate identical industrial products?," *Industrial Marketing Management*, 8 (2), pp. 114-123.

Schlaberg, F. (1997), *Wettbewerbsvorteil und Bewertung von Marken: Entwicklung eines Bewertungsmodells zur Effizienzsteigerung im Markenmanagement und -controlling auf Basis mikroökonomisch und finanztheoretisch fundierter Untersuchungen*, Bamberg.

Schmitt, P. (1969), "Vertikaler Ideenverbund durch Rohstoffmarken," *Jahrbuch der Absatz- und Verbrauchsforschung*, 15, pp. 235-246.

Schoenbachler, D.D., G. L. Gordon and T.W. Aurand (2004) "Building brand loyalty through individual stock ownership," *Journal of Product & Brand Management*, 13(7), pp. 488-497.

Sellert, H. (1927), *Markenartikel und Preispolitik*, Freiburg.

Simon, H. and Sebastian, K.-H. (1995), "Ingredient Branding – Reift ein neuer Markentypus," *Absatzwirtschaft*, 45(6), pp. 42-48.

Simonin, B.L. and J.A. Ruth (1998), "Is a company known by the company it keeps? Assessing the spill-over effects of brand alliances on consumer brand attitudes," *Journal of Marketing Research*, 35(1), pp. 30-42.

Smit, M. (1999), *Ingredient Branding*, in, *Co-Branding – The Science of Alliance*, Blackett, T. and Boad, B. (Eds.), Houndsmills et al., pp. 66-83.

Srivastava, R. K. and A.D. Shocker. (1991), *Brand Equity: A Perspective on its Meaning and Measurement*, Technical Working Paper, Marketing Science Institute, Report Nr. 91 – 124: Cambridge.

Subrahmanyam, S. (2004), "Effects of price premium and product type on the choice of cause-related brands: a Singapore perspective," *Journal of Product & Brand Management*, 13(2), pp. 116-124

Thurmann, P. (1961), *Grundformen des Markenartikels – Versuch einer Typologie*, Berlin.

Tybout, A.M., B.J. Calder and B. Sternthal (1981), „Using information processing theory to design marketing strategies,” *Journal of Marketing Research*, 18, pp.73-79.

Unger-Firnhaber, A. E. (1996), *Pull strategies for component suppliers in Business-to-Business markets*, St. Gallen.

Urban, G.L., F. Sultan, and W.J. Qualls (2000), “Placing trust at the center of your internet strategy,” *MIT Sloan Management Review*, 42 (Fall), pp.39-49.

Vaidyanathan, R. and M. G. Brown (1997), *National brand – Private brand strategy alliance though ingredient branding*, Working Paper, University of Minnesota: Rochester.

Van Osselaer, S. M. J. and C. Janiszewski (2001), “Two ways of learning brand association,” *Journal of Consumer Research*, 28 (2), pp. 202-223.

Vargo, S. L. and R. F. Lusch (2004), “Evolving to a new dominant logic for marketing,” *Journal of Marketing*, 68(1), pp. 1-17.

Venkatesh, R. and V. Mahajan (1997), “Products with branded components: An approach for premium pricing and partner selection,” *Marketing Science*, 16(2), pp. 146-165.

Washburn, J.H., B.D. Till and R. Priluck (2004), “Brand alliance and customer based brand equity effects,” *Psychology and Marketing*, 21(7), pp. 487–508.

Wathne, K.H. and J. B. Heide (2004), “Relationship governance in a supply chain network,” *Journal of Marketing*, 68(1), pp. 73-89.

Wathne, K.H., H. Biongand J.B. Heide (2001), “Choice of supplier in embedded markets: Relationship and marketing program effects,” *Journal of Marketing*, 65 (2), pp. 54-66.

Webster, F. E. Jr. and K. L. Keller (2004), “A roadmap for branding in industrial markets,” *Journal of Brand Management*, 11(5), pp. 388-402.

Wiezorek, H. and A. Wallinger (1997), *Wachstum mit Gewinn*, Frankfurt a. M.

Wilkinson, I. (2001), “A history of network and channels thinking in marketing in the 20th century,” *Australasian Journal of Marketing*, 9(2), pp. 23-53.

Wuyts, S., S. Stremersch, C.V. Den Bulte nd P. H Franses. (2004), “Vertical marketing systems for complex products: A triadic perspective,” *Journal of Marketing Research*, 41(4), pp. 479-487.