



<b>Title</b>	The s-mote: a versatile heterogeneous multi-radio platform for wireless sensor networks applications
<b>Author(s)</b>	Popovici, Emanuel M.; Boyle, David; O'Connell, Seán; Faul, Stephen; Angove, Philip; Buckley, John; O'Flynn, Brendan; Barton, John; Ó Mathúna, S. Cian
<b>Publication date</b>	2011-08-31
<b>Original citation</b>	POPOVICI, E., BOYLE, D., O'CONNELL, S., FAUL, S., ANGOVE, P., BUCKLEY, J., O'FLYNN, B., BARTON, J. & O'MATHUNA, C. The s-Mote: A versatile heterogeneous multi-radio platform for wireless sensor networks applications. Circuit Theory and Design (ECCTD), 2011 20th European Conference on, 29-31 Aug. 2011. pp. 421-424. doi: 10.1109/ECCTD.2011.6043376 URL: <a href="http://ieeexplore.ieee.org/stamp/stamp.jsp?tp=&amp;arnumber=6043376&amp;isnumber=6043284">http://ieeexplore.ieee.org/stamp/stamp.jsp?tp=&amp;arnumber=6043376&amp;isnumber=6043284</a>
<b>Type of publication</b>	Conference item
<b>Link to publisher's version</b>	<a href="http://ieeexplore.ieee.org/stamp/stamp.jsp?tp=&amp;arnumber=6043376&amp;isnumber=6043284">http://ieeexplore.ieee.org/stamp/stamp.jsp?tp=&amp;arnumber=6043376&amp;isnumber=6043284</a> <a href="http://dx.doi.org/10.1109/ECCTD.2011.6043376">http://dx.doi.org/10.1109/ECCTD.2011.6043376</a> Access to the full text of the published version may require a subscription.
<b>Rights</b>	<b>(c) IEEE Personal use of this material is permitted. Permission from IEEE must be obtained for all other users, including reprinting/ republishing this material for advertising or promotional purposes, creating new collective works for resale or redistribution to servers or lists, or reuse of any copyrighted components of this work in other works.</b>
<b>Item downloaded from</b>	<a href="http://hdl.handle.net/10468/513">http://hdl.handle.net/10468/513</a>

Downloaded on 2017-02-12T08:04:33Z



# UCC

University College Cork, Ireland  
Coláiste na hOllscoile Corcaigh

# The s-Mote: a Versatile Heterogeneous Multi-Radio Platform for Wireless Sensor Networks Applications

E. Popovici<sup>1,2</sup>, D. Boyle<sup>1,2</sup>, S. O'Connell<sup>1,2</sup>, S. Faul<sup>1</sup>

<sup>1</sup>Department of Electrical and Electronic Engineering  
University College Cork  
Ireland

P. Angove<sup>2</sup>, J. Buckley<sup>2</sup>, B. O'Flynn<sup>2</sup>, J. Barton<sup>2</sup>, C. O'Mathúna<sup>2</sup>

<sup>2</sup>Tyndall National Institute  
University College Cork  
Ireland

**Abstract**—This paper presents a novel architecture and its implementation for a versatile, miniaturised mote which can communicate concurrently using a variety of combinations of ISM bands, has increased processing capability, and interoperability with mainstream GSM technology. All these features are integrated in a small form factor platform. The platform can have many configurations which could satisfy a variety of applications' constraints. To the best of our knowledge, it is the first integrated platform of this type reported in the literature. The proposed platform opens the way for enhanced levels of Quality of Service (QoS), with respect to reliability, availability and latency, in addition to facilitating interoperability and power reduction compared to existing platforms. The small form factor also allows potential of integration with other mobile platforms including smart phones.

**Keywords:** *wireless sensor networks, multi radio, mote platforms, embedded systems*

## I. INTRODUCTION

Wireless Sensor Networks (WSN) are gaining fast applicability in many areas including security, mobile health, structural health and environmental monitoring, smart buildings, smart grid, automotive, home automation, home assisted living, etc. To accommodate the requirements of these applications a significant number of platforms were proposed in the both commercial and academic works. A comprehensive review, including 43 platforms of wireless sensor mote hardware was performed [1-3]. The current trend for these types of wireless mote implementations is to employ a single low power RF transceiver for radio communications. Approximately 95% of the reviewed platforms employ a single radio transceiver.

A large percentage of these motes use a radio chip which conforms to the IEEE 802.15.4 standard. One of the most common IEEE 802.15.4 compliant radio transceiver devices is the TI CC2420 device from Texas Instruments/Chipcon [4]. This is a single-chip 2.4 GHz IEEE 802.15.4 compliant RF transceiver designed for low power and low voltage wireless applications with an effective radio data rate of 250 kbps.

Only 2 of the reviewed nodes employ a multi-radio feature. The BTnode platform features two radios. It incorporates a Chipcon CC1000 low power radio (433-915 MHz) and a ZV4002 Bluetooth radio (2.4 GHz) [5]. The BTnode (Rev3) can operate both radios simultaneously or shut them down independently when not in use.

Another example of a two-radio wireless node is the Shimmer mote [6]. This mote is a wireless sensor platform designed to support wearable applications. The mote features a CC2420 IEEE 802.15.4 radio and can also be configured with an optional Bluetooth radio. The Wasp Mote [7] can also incorporate Zigbee and Bluetooth with separate modular plug-in boards. It also has separate 868 and 900MHz radio modular plug-in boards. Its main disadvantage is that only a single radio module can be operated at a time so it is not a multi-radio in our sense. The mPlatform node [8] uses both 802.11 and 802.15.4 radios. The platform uses a reconfigurable architecture and efficient data sharing mechanism for modular sensor nodes and each module has its own processor. Recently, a two radio implementation was considered linking two platforms operating on 433Mhz and 2.4Ghz frequency bands showing some important gains in overall power consumption [9]. Another approach to multi-radio implementation is given in [10], and implements four (Nordic) nRF2401 RFICs in parallel, with a flexible FPGA-based computing subsystem.

However, each transceiver functions solely in the 2.4 GHz ISM band. The platform proposed in this paper can be configured to have any of the presented radio features while adding more connectivity (more ISM bands, GSM) and available processing power (DSP and/or FPGA). It allows concurrent communication over two ISM bands and it provides the option to switch between bands dynamically, providing a range of potential improvements in QoS.

The paper is organized as follows. Section II presents the architecture of the proposed platform. Section III presents some of the potential configurations and applicability of the platform, with some results, while Section IV presents the conclusion.

## II. PROPOSED ARCHITECTURE

The architecture of the s-Mote is developed around the concept of stackable modular connector system characteristic

of the 25 mm Tyndall mote [11] [14] [15]. This feature enables simplified reconfiguration of the platform depending on application specific requirements, including: power consumption, sensing, communications and processing.

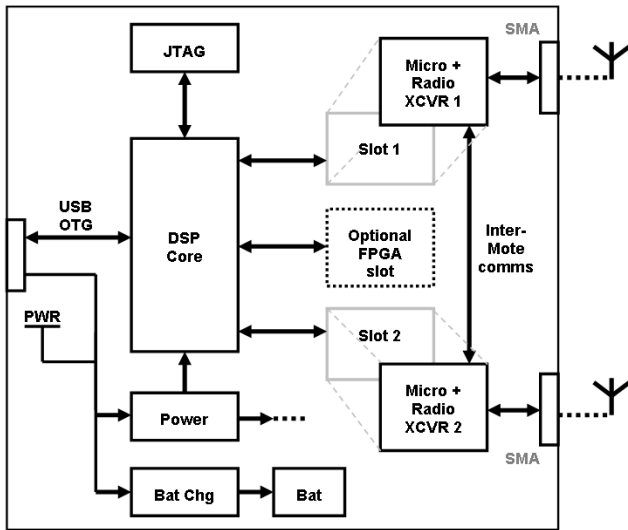

Figure 1. Block diagram of the proposed s-Mote

The first goal of the s-Mote development is to facilitate the efficient implementation of communication and signal processing algorithms for a wide range of applications of WSNs. The second goal is to achieve maximum interoperability between various networks including ISM band WSN, GSM, Bluetooth, etc. The architecture of the proposed system is presented in Figure 1. It consists of a powerful DSP block, two slots which can accommodate ISM band radio transceivers, a power management unit, two antennas and a versatile USB connectivity unit (e.g. allowing interconnectivity with a mobile phone). The two 25mm by 25mm slots (Slot 1 and Slot 2) can be stacked with a 25mm Tyndall mote [18] using a variable number of layers on top of each other in order to satisfy application requirements (Figure 2). Over 30 system layers have been developed with various sensor functionality, ISM band transceiver capability and power supply and energy harvesting options [16-18]. There are a number of benefits in adopting this modular approach for the Tyndall mote. The platform permits interoperability with a wide range of wireless technologies, and should there be a need to change technology, the background functionality of the network is retained and the need for sensor recalibration is removed. In addition, the embedded intelligence within the system can provide the necessary filtering and processing algorithms to enable autonomous operation, adaptive sampling regimes based on sensory input and data filtering using readily available embedded C or TinyOS code libraries.

The processing/communications layer that is present in all configurations of the 25mm mote is the ISM band RF transceiver layer. The most commonly used consists of an Atmel ATmega128 microcontroller and an Ember EM2420 enabling communication with other ZigBee devices (Micaz, Tmote, etc), as it is compliant with the IEEE802.15.4 standard. An alternative transceiver layer has a Nordic Semiconductor

nRF2401 radio which has a higher data rate (1Mbit/s, compared to 250kbit/s) than the Ember EM2420, which may be a requirement for certain applications. Finally, a versatile layer is configured with an Analog ADF7020 transceiver (433/868 MHz) and an MSP430 microcontroller.



Figure 2. Stackable 25mm Tyndall mote

The s-Mote platform can be readily used for any WSN application which requires in-network processing, and/or high reliability of communications and/or high rate communications and/or prolonged lifetime. The versatility and novelty of the platform resides in the fact that two ISM band radios (from Analog Devices, Nordic and/or Texas Instruments) and the associated two low power microcontrollers (MSP or Atmega) can be used simultaneously, allowing a multitude of radio configurations (covering the most popular ISM bands). For increased processing requirements we consider a low power Analog Devices Blackfin DSP present on a versatile Bluetechnix board [12], and/or a low power FPGA (Spartan from Xilinx). The DSP unit also incorporates an extended memory block of 32Mb. The platform can act stand-alone or in conjunction with a smart/mobile phone for increased interoperability of WSN with GSM/Bluetooth/Wi-Fi, etc. This is done using a USB connection. The small form factor realization on a 5cm by 6cm PCB is presented in Figure 3.

The multi-radio is currently implemented over the most popular ISM frequency bands. However, it can be easily extended to any band, allowing for adaptive protocol development, enhanced QoS, etc. In particular, a software defined radio (SDR) [13] could be implemented allowing capability of using additionally licensed bands for emergency signal relay.

The multi-radio capability can be used to implement a MIMO scheme for improved rate as well as improved reliability (by switching between various radios). Further to this a re-configurable/SDR approach could be implemented due to the inclusion of a slot for a pluggable FPGA (Xilinx Spartan). The USB feature enables interoperability with smart phone technology allowing further extension of wireless capability to GSM and Bluetooth.

Due to the smart, low-power operating circuit topology used, the system can remain in a buffered low power/sleep mode until USB data download is required, or critical event recording is required. The system is then optimised for use in highly power-constrained battery operated systems such as wireless sensor networks. All the constituent components are off the shelf, resulting in a low cost solution. It opens a number of research avenues in the broad area of wireless sensor

networks, ambulatory signal processing, gaming/entertainment, structural health monitoring, sensor web, smart grid, home automation, assisted living, etc.

In our prototype we have two radios (which can be on same or different frequency bands). Each radio is controlled by a dedicated low power microcontroller (MSP430 and/or Atmega128). The two microcontrollers in the prototype can communicate between each other (via UART) or with a DSP (through the use of a parallel bus).

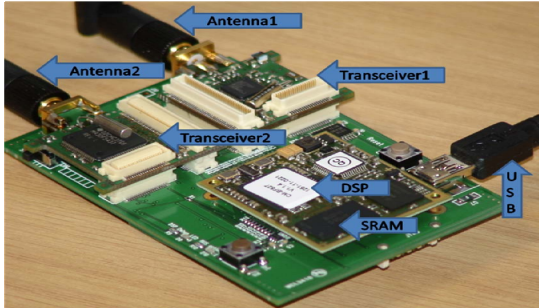

Figure 3. Small form factor s-Mote platform

Some of the key features for the s-Mote include:

- Re-configurable multi-band radio (SDR) - in particular for ISM band mote frequencies (traditionally SDR used for: 3G, GSM, WiFi, etc.)
- Re-configurable processing power from low power mote to high end critical signal event detection (DSP / FPGA),
- Power management with capability for operation in power/battery constrained system using deep sleep mode.
- The platform can be used as low latency base station receiver with significant processing capabilities for body area networks.
- Support for multiple radio interfaces including Tyndall 25mm ADF7020/MSP430 and IEEE 802.15.14/ZigBee compliant CC2420/ATMega1281 platforms. Due to the generic nature of the interface, further support for differing ISM band radio chipsets is envisaged. The current prototype supports a synchronous high speed serial port (SPORT) interface between ADI ADF7020 RF 433 – 868MHz transceiver & Blackfin BF527 DSP.
- Compatibility with other Tyndall 25mm sensor layers (ECG, Wireless Inertial Measurement Unit (WIMU), Accelerometers, GPS, etc).

### III. APPLICATIONS

The primary applicability of this multi-radio approach is in the enhancement of QoS provision for WSNs. It has been proven that as the depth of the network increases (i.e. the number of hops that a sensing node is from a sink/gateway) reliability (with respect to packet loss) degrades to unacceptable levels, subsequently giving rise to a higher number of retransmissions (thereby significantly increasing

power consumption), in addition to an increase in the end-to-end delay (latency) between an event being detected/sensed and notification to a relevant authority. In the context of multi-constrained Quality of Service (MC-QoS) parameters/metrics, increasingly exhibited by a range of potential deployment scenarios, advances can be made through the use of a multi-radio platform, such as the one proposed, operating over multiple ISM bands. If one considers the differences in range of communication between, for example, the 433 MHz and 2.4 GHz bands, with respect to power budget, associated hop-count and reliability (link-quality), the opportunity to improve QoS emerges by dynamically switching between ISM bands. Implementing the proposed platform as coordinator (of a cluster-tree topology, for example) could lead to significant improvement in the practicability of largely geographically distributed WSN deployments with respect to the satisfaction of QoS requirements (Figure 4).

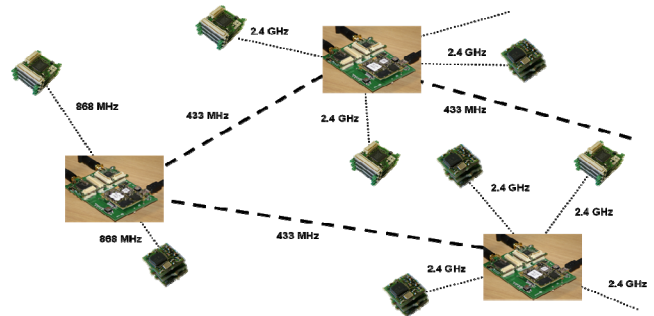

Figure 4. Heterogeneous WSN using the s-Mote

The proposed platform can provide significant improvements on reliability, latency, availability, energy conservation, scalability and distribution. Some power consumption figures for two transceiver layers and the s-Mote are given in Table 1.

TABLE I. POWER CONSUMPTION RESULTS

	Power Consumption by Mode		
	Stand-by	Tx/Rx	Processing
<b>433MHz ADF7020 RF layer + MSP430</b>	7 $\mu$ W	45/63 mW	4mW (respiration rate using SpO2 sensor)
<b>2.4GHz EM2024 RF + Atmega 124L</b>	18 $\mu$ W	64/72 mW	22mW (building management system)
<b>s-Mote (DSP + 2 x 433MHz RF)</b>	28 $\mu$ W	90/126mW (2 x 433 MHz RF)	136mW(real-time seizure detection using EEG)

The presented transceiver layers were deployed in medical applications and building management systems. The s-Mote is currently used to improve the QoS in the context of patient monitoring using accelerometers and ECG. The s-Mote is currently being evaluated as an in-network processor in this application for fall detection as part of a patient alarm system. Also, the DSP layer of the s-Mote in conjunction with the 433MHz ADF/MSP layer was instrumental in achieving low power remote EEG monitoring for real-time seizure

detection [19, 20]. Also, it is envisaged that the proposed multi-radio platform will be evaluated in the context of structural monitoring. It is expected that significant improvements in receive rates for alarm conditions, and reduced latency and power consumption (distributed across the network) will be observed.

#### IV. CONCLUSIONS

The proposed s-Mote facilitates the efficient implementation of communication and signal processing algorithms for a wide range of applications of WSN. The platform can be readily used for any wireless sensor network application which requires in-network low power processing, and/or high reliability of communications and/or high rate communications and/or prolonged lifetime. The versatility and novelty of the platform resides in the fact that multiple radios and multiple low power microcontrollers/DSP are used, allowing a multitude of radio configurations, DSP, memory and FPGA possibilities. The platform can act stand-alone or in conjunction with a smart/mobile phone for increased interoperability of WSN with GSM / Bluetooth / Wi-Fi etc. The multi-radio is currently implemented as a stand-alone platform covering all ISM bands.

Further to this a re-configurable/software defined radio (SDR) approach could be implemented due to the inclusion of a pluggable low power FPGA. The proposed architecture opens a new generation of protocols, smart phone apps for the next generation smart Wireless Sensor Networks. The presented platform is capable of acting as a sink node with GSM connectivity when used in conjunction with a suitable mobile device like a smart phone. This can potentially increase network capacity and decrease the load on existing sinks. Future work will concentrate on further power optimization, miniaturization and diversification of the application base for the proposed platform. Expected improvements with respect to enhanced levels of QoS will be thoroughly evaluated with respect to the application base.

#### ACKNOWLEDGMENT

We would like to acknowledge the generous support of SFI (grant numbers NAP 258, 07/CE/I1147, 07/SRC/I1169) and EC-FP7 Genesi: Green sensors for structural health monitoring. The authors would also like to acknowledge the support of Science Foundation Ireland (SFI) in funding the National Access Program (NAP) at the Tyndall National Institute, Irelands Higher Education Authority and Enterprise Ireland all of which have funded aspects of this work. Tyndall is part of the SFI funded CLARITY Centre for Sensor Web Technologies under grant 07/CE/I1147.

#### REFERENCES

- [1] M. Healy, T. Newe and E. Lewis (2009) "Security for Wireless Sensor Networks: A Review". *IEEE Sensors Applications Symposium (IEEE SAS 2009)*, February 17th–19th, 2009. New Orleans, LA, USA. pp 80-85. ISBN: 978-1-4244-2787-1
- [2] Wikimedia Foundation (2011) "List of wireless sensor nodes" [online], available: [http://en.wikipedia.org/wiki/List\\_of\\_wireless\\_sensor\\_nodes](http://en.wikipedia.org/wiki/List_of_wireless_sensor_nodes) [accessed: 18 July 2011]
- [3] T. Bokareva (University of New South Wales) "Mini Hardware Survey" [online], available: [http://www.cse.unsw.edu.au/~sensor/hardware/hardware\\_survey.html](http://www.cse.unsw.edu.au/~sensor/hardware/hardware_survey.html) [accessed: 18 July 2011].
- [4] Texas Instruments (2010) CC2420 Datasheet [online], available: <http://focus.ti.com/lit/ds/symlink/cc2420.pdf> [accessed: 18 July 2011].
- [5] ETH Zurich (2007) "BTnodes - A Distributed Environment for Prototyping Ad Hoc Networks" [online], available: <http://www.btnode.ethz.ch/> [accessed: 18 July 2011]
- [6] SHIMMER Research (2011) "SHIMMER – Wireless Sensor Platform for Wearable Applications" [online], available: <http://www.shimmer-research.com> [accessed: 18 July 2011].
- [7] Libelium Comunicaciones Distribuidas S.L. (2011) "Wasp mote – Wireless Sensor Networks 802.15.4 ZigBee" [online], available: <http://www.libelium.com/products/waspote/hardware> [accessed: 18 July 2011].
- [8] D. Lymberopoulos, N.B. Priyantha, M. Goraczko, Z. Feng (2008) "Towards Energy Efficient Design of Multi-radio Platforms for Wireless Sensor Networks", *Information Processing in Sensor Networks, 2008 – IPSN '08. International Conference on*, pp 257-268
- [9] J. Gummeson, D. Ganesan, M. D. Corner, and P. Shenoy (2010) "An Adaptive Link Layer for Heterogeneous Multi-Radio Mobile Sensor Networks", *IEEE JSAC*, Sept 2010.
- [10] M. Kohvakka, T. Arpinen, M. Hannikainen, and T. Hamalainen (2006) "High-performance multi-radio WSN platform". *REALMAN '06 Proceedings of the 2nd international workshop on multi-hop ad hoc networks: from theory to reality*, ACM.
- [11] B. O'Flynn, A. Lynch, K. Aherne, P. Angove, J. Barton, S. Harte, C. O'Mathuna, D. Diamond, F. Regan (2006) "The Tyndall Mote: Enabling Wireless Research and Practical Sensor Application Development". *Proc of Pervasive 2006*
- [12] Bluetechnix (2011) "Bluetechnix – Blackfin / Freescale Processor Modules and Development" [online], available: <http://www.bluetechnix.com/> [accessed: 18 July 2011]
- [13] P. Amini, E. Azarnasab, S. Akoum, B. Farhang-Boroujeny (2008) "RF-MEMS: An Experimental Cognitive Radio for First Responders", *DySPAN 2008. 3rd IEEE Symposium on New Frontiers in Dynamic Spectrum Access Networks*, Oct 2008, Chicago, IL
- [14] B. O'Flynn, S. Bellis, K. Mahmood, M. Morris, G. Duffy, K. Delaney and C. O'Mathuna (2005) "A 3-D Miniaturised Programmable Transceiver", *Microelectronics International*, Volume 22, Number 2, 2005, 8-12.
- [15] S.J. Bellis, K. Delaney, B. O'Flynn, J. Barton, K.M. Razeed and C. O'Mathuna (2005) "Development of field programmable modular wireless sensor network nodes for ambient systems", *Computer Communications - Special Issue on Wireless Sensor Networks and Applications*, Volume 28, Issue 13, (2005), 1531-1544.
- [16] J. Barton, G. Hynes, B. O'Flynn, K. Aherne, A. Norman and A. Morrissey (2006) '25mm sensor-actuator layer: A miniature, highly adaptable interface layer', *Sensors and Actuators A: Physical* 132 (2006).
- [17] C. Ó Mathúna, T. O'Donnell, R.V. Martinez-Catala, J. Rohan and B. O'Flynn (2008) 'Energy Scavenging for Long-Term Deployable Mote Networks', *Talanta*, Volume 75, Issue 3, (2008), 613-623
- [18] S. Harte, E.M. Popovici, B. O'Flynn, and S.C. Ó Mathúna (2008) "THAWS: automated design and deployment of heterogeneous wireless sensor networks", *WSEAS Trans. Circuits and Systems*, vol. 7, no. 9, pp. 829-838, Sept. 2008
- [19] W.P. Mamane, S. Faul, C. Bleakley, R. Conway, E. Jones, E. Popovici, M. de la Guia Solaz, F. Morgan, and K. Patel (2010) "Energy Efficient On-Sensor Processing In Body Sensor Networks," *IEEE EMBS Conference*, 2010.
- [20] R. McEvoy, S. Faul and W. Mamane (2010) "REACT: Real-time Seizure Detection with a DSP Microprocessor", *Proc. of the IEEE EMBS 2010*, pp 2443-2446.