

A Study on the Abrasion Effect by ^{60}Co - γ ray
Irradiation for Dental P.M.M.A. (Part I)

Hiroshi KIMURA*, Takuji YAMAGUCHI**,
Tetsuro SHIRAISHI**, Masakazu TSUBOKAWA**

(Received Jul. 24, 1980)

Reported in this article are results of experiment in which di- and tri-methacrylic acid esters and di- and tri-allyl compounds are used as cross linking monomer to coat P.M.M.A., irradiated with radioactivity to bring about linking reaction and improvement in linking density, so that the abrasion resistance of the dental P.M.M.A. can be improved.

It was found that to add diallyl compound to unsaturated polyester and to coat the material with curing catalyzer as coating material added with M.E.K.P.O. and naphthenic acid cobalt and to irradiate with radioactivity to enrich cross linking density after hot press processing were very effective as a treatment to improve abrasion resistance of dental P.M.M.A..

1. INTRODUCTION

Dental P.M.M.A. has advantages in molding, processing and aesthetical properties as well as in lightness in weight, anti-corrosion property and economic view point, and is widely used for artificial teeth and dental bases. However, being inferior in abrasion resistance, it is easily abraded and worn, luster on the surface and esthetical properties deteriorate, and there are cases when the function itself changes for worse. Reported in this article are results of experiment in which di- and tri-methacrylic acid esters and di- and tri-allyl compounds are used as cross linking monomer to coat P.M.M.A., irradiated with radioactivity to bring about linking reaction and improvement in linking density, so that the abrasion resistance of the dental P.M.M.A. can be improved. 1)~ 9)

* Osaka University Dental School, Department of Dental Technology

** Fukui University, Department of Textile Engineering

2. EXPERIMENTAL MATERIALS AND EXPERIMENTAL METHOD

Composition and treatment of the surface coating material were as follows: viz. 0.5g of mono-, di- and tri-esters of methacrylic acid and di- and tri-allyls were added as linking material to 2g of unsaturated polyester resin for common laminate (RIGOLAC 1057 made by Showa High Polymer Co., Ltd.) for the purpose of viscosity control, and 1.5% of M.E.K.P.O. and 1% of naphthenic acid cobalt were then added to the resin as curing catalyzer. 5% of silica was further added to the material identified as SCS specimen in an attempt to improve surface hardness and abrasion resistance properties. After being applied to dental P.M.M.A., the above-mentioned coating agent was dried for 20 hours in vacuum dryer kept at 30°C. However, as the same did not harden yet, the specimen was then placed between flat plates and heat-hardened for 4 hours in hot press kept at 80°C. Heat-cured type resin (Denture Acrylic SHOFU "Bio") was used for dental P.M.M.A., and molding condition was that it was subjected to compression-forming in hot press for 45 minutes at 100°C under 100kg/cm², thence hardened by natural cooling. Rational formula of monomer for linking and composition and volume of application of coating material are shown in Tables 1 and 2 respectively. Test pieces were in long rectangular shape of 40 x 10 x 2.5mm. Irradiation of ⁶⁰Co-γ rays was carried out using 45 KCi energy source of Japan Atomic Energy Research Institute placed 40cm away from the test pieces, and conditions of irradiation were that the irradiation ratio was 1.1 x 10⁵r/hr, duration 50 hours, total irradiation dose 5.5 x 10⁶r and time of irradiation from 8th to 10th December, 1979. Tests on abrasion resistance of the test pieces so prepared consisted of brushing test, barrel test, surface shape test, S.E.M. test, etc., and results of brushing test are reported in this article. In order to carry out brushing test, a special apparatus as shown in Fig.1 was made, with which 24 test pieces can be set at one time on the turn table turning at 18rpm. and brushed up with 2 brushes with constant pressure under immersed condition in tooth powder as shown in Table 3, so that each one of the test pieces is subjected to the abrasion test under the identical condition.

3. EXPERIMENTAL RESULTS AND CONSIDERATION

This article is to report the results of experiment in which qualitative data concerning effectiveness of irradiation of ⁶⁰Co-γ rays to improve abrasion resistance with various coating materials, coating

Table 2 Composition of coating materials and coated quantity.

Mark of specimen	Unsaturated polyester (g)	Monomer for crosslinking (g)	Catalyzer (g)			Coated quantity (g)
			MEKPO	*Co	SiO ₂	
SA	2	MMA 0.5	0.03	0.02		0.0128
SB	2	HEMA 0.5	0.03	0.02		0.0068
SC	2	GMA 0.5	0.03	0.02		0.0030
SD	2	EDMA 0.5	0.03	0.02		0.0423
SE	2	TMPMA 0.5	0.03	0.02		0.0746
SF	2	DAC 0.5	0.03	0.02		0.0675
SG	2	DAP 0.5	0.03	0.02		0.0512
SH	2	TAPM 0.5	0.03	0.02		0.0650
SI	2	TAC 0.5	0.03	0.02		0.0080
SK	2	TAIC 0.5	0.03	0.02		0.0254
SAS	2	MMA 0.5	0.03	0.02	0.125	0.0223
SBS	2	HEMA 0.5	0.03	0.02	0.125	0.0239
SCS	2	GMA 0.5	0.03	0.02	0.125	0.0157

*Co:Naphthenic acid cobalt

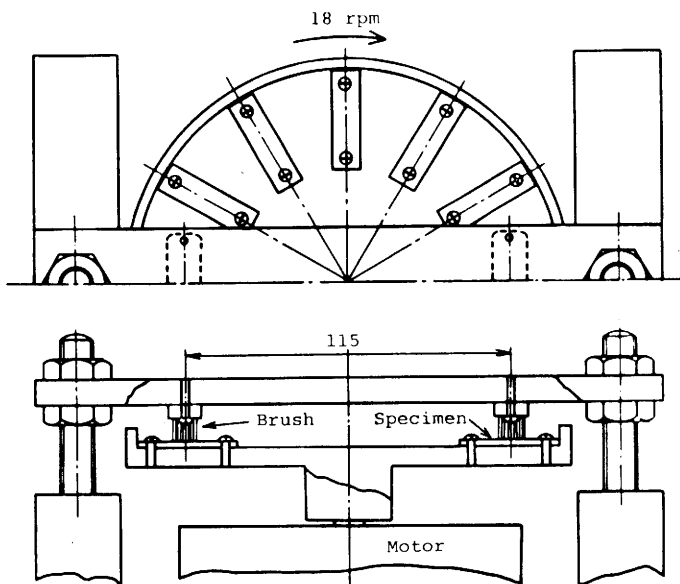

Fig.1 Self-made abrasion testing machine by brushing method.

Table 3 Composition of the tooth-paste (White and White Lion).

Function	Material
Abrasives	Hydrogen phosphate for tooth-paste
Wetting agent	Silicic anhydride
Foaming agent	Lauric sodium sulfate
Caking agent	Sodium carboxymethylcellulose
Spice agent	Sodium saccharin
Preservation agent	Paraoxy ethyl benzoic acid
Medicinal agent	Chloro hexigine hydrochloride

where, Brush:Lion T1 MO 15,pig fur,hardness;normal

Table 4 Results of abrasion tests of coated specimen.

Mark of specimen	*Amount of abrasion (mm)		Remarks
	after 5 hrs	after 10 hrs	
SA	0.02	0.02	
SB	0.02	0.05	
SC	0.03	0.04	
SD	0.02	0.05	
SE	0.03	0.04	
SF	0.00	0.00	Best 1
SG	0.04	0.08	
SH	0.00	0.01	Best 2
SI	0.04	0.08	
SK	0.03	0.06	
SAS	0.02	0.05	
SBS	0.04	0.06	
SCS	0.03	0.05	
Dental PMMA	0.03	0.06	
Dental PMMA AR processing	0.02	0.06	
**Mitsubishi Acrylite	0.03	0.05	

* Amount of abrasion is a decrement of specimen thickness measured by micrometer before and after test.

**Industrial PMMA plate.

rays by 5.5×10^6 r was found to be effective.

4. CONCLUSION

The following summary can be made from the results of the research. It was found that to add diallyl compound to unsaturated polyester and to coat the material with curing catalyzer as coating material added with M.E.K.P.O. and naphthenic acid cobalt and to irradiate with radioactivity to enrich cross linking density after hot press processing were very effective as a treatment to improve abrasion resistance of dental P.M.M.A..

ACKNOWLEDGMENTS

The irradiation facility of the Japan Atomic Energy Research Institute at Tokai was used for γ -ray irradiation of this study.

The author wishes to express sincere thanks to Dr. Yasuo ITO, Mr. Katsuo TAKAHASHI and Mr. Takemi TAKANO of National Universities' Laboratory for the Common Use of JAERI Facilities.

REFERENCES

- 1) Dirksen, L.C.: Plastic Teeth; Their Advantages, Disadvantages and Limitations. J.A.D.A., 44:265-268 (march), 1952.
- 2) Eugene W.Skinner and Ralph W.Phillips: The Science of Dental Materials, W.B.Saunders Company, 154, 1960.
- 3) H.Kimura, T.Yamaguchi, T.Shiraishi, M.Tsubokawa and T.Hirai: A Study on the Irradiation Effect of ^{60}Co - γ ray for Dental P.M.M.A. Bonded Parts - Welding of Dental P.M.M.A.-, The Journal of the Japan Research Society of Dental Materials & Appliances, Vol.36, No.4, p.507-515, 1980.
- 4) Japan Atomic Energy Research Institute: Explanation of Public Use of Japan Atomic Energy Research Institute(No.4), Business Guide No.1, 1962.
- 5) H.Kimura, T.Yamaguchi, T.Shiraishi, M.Tsubokawa, Y.Fukuda, T.Nishiura and Y.Okuno: A Study on the Composite Teeth of Polyester Resin/Glass Bead, The Journal of the Japan Research Society of Dental Materials & Appliances, Vol.36, No.3, p.390-397, 1979.
- 6) H.Kimura, T.Yamaguchi, T.Shiraishi, M.Tsubokawa, T.Hirai, J.Awataani, T.Nishiura, S.Kawai, Y.Okuno and H.Matsushiro: A Study on the Composite Teeth of Polyester Resin/Feldspar, The Journal of

the Japan Research Society of Dental Materials & Appliances, Vol. 35, No.3, p.251-258, 1978.

- 7) H.Kimura, T.Yamaguchi, T.Shiraishi, M.Tsubokawa and F.Teraoka: Irradiation Effect on the Welded Part of Polyethylene, Journal of the Society of Materials Science, Japan, Vol.27, No.296, p.416-421, 1978.
H.Kimura, T.Yamaguchi, T.Shiraishi, M.Tsubokawa and F.Teraoka: Irradiation Effect of Radioactivity on the Welded Material of Polyethylene, International Institute of Welding, Document No.XVI-330-78, 1978.
- 8) K.Kamata, Y.Yoshihara, T.Ikeda and K.Kushi: Method of Treatment of Plastic Artificial Tooth, Public Official Report of Patent, 1978-13589, Application for Patent 1976-83657, 1978.
- 9) K.Kamata, Y.Yoshihara, T.Ikeda and K.Kushi: Plastic Artificial Denture Base, Public Official Report of Patent, 1978-82088, Application for Patent 1976-156966, 1978.

