



University of HUDDERSFIELD

University of Huddersfield Repository

Gilkes, Oliver S., Mishra, Rakesh, Rao, H.V. and Fieldhouse, John D.

Transient response of turbocharged diesel engine for transient operation using air injection assist system

Original Citation

Gilkes, Oliver S., Mishra, Rakesh, Rao, H.V. and Fieldhouse, John D. (2007) Transient response of turbocharged diesel engine for transient operation using air injection assist system. In: Proceedings of Computing and Engineering Annual Researchers' Conference 2007: CEARC'07. University of Huddersfield, Huddersfield, pp. 1-7.

This version is available at <http://eprints.hud.ac.uk/3790/>

The University Repository is a digital collection of the research output of the University, available on Open Access. Copyright and Moral Rights for the items on this site are retained by the individual author and/or other copyright owners. Users may access full items free of charge; copies of full text items generally can be reproduced, displayed or performed and given to third parties in any format or medium for personal research or study, educational or not-for-profit purposes without prior permission or charge, provided:

- The authors, title and full bibliographic details is credited in any copy;
- A hyperlink and/or URL is included for the original metadata page; and
- The content is not changed in any way.

For more information, including our policy and submission procedure, please contact the Repository Team at: E.mailbox@hud.ac.uk.

<http://eprints.hud.ac.uk/>

TRANSIENT RESPONSE OF TURBOCHARGED DIESEL ENGINE FOR TRANSIENT OPERATION USING AIR INJECTION ASSIST SYSTEM

O. S. Gilkes¹, R. Mishra¹, V. Rao¹ and J. Fieldhouse¹

¹ University of Huddersfield, Queensgate, Huddersfield HD1 3DH, UK

ABSTRACT

Great improvements have been made in engine performance and emission control due to recent intensive research on engine systems. Further improvements are still required and turbocharging is aiding further improvements in emissions, power and downsizing. Turbocharged vehicles, however, exhibit a weak point of poor drivability under transient running conditions. This poor drivability has a detrimental affect on the engines emission output during the transient phase. Various methods are being researched to improve transient performance of turbocharged engine systems.

This study analyses the effectiveness of injecting air into the inlet manifold and the compressor at improving the transient performance of a turbocharged diesel engine when performing rapid load changes. The paper expands upon previous work carried out which demonstrates the potential of the system.

Computer simulations have been used to analyse the transient engine performance including the drive train. The transient engine models have been developed to analyse the transient engine performance with various injection strategies. The air injection system was modelled by injecting air into the plenum on the intake manifold and using an additional torque on the compressor wheel. The injection pressure was set at a pressure of 3 bar, which is in commonly used range. The valve and additional compressor torque were programmed to activate at the same instant that the transient regime begins.

To assess the effectiveness of the air injection strategies at improving the transient response of the engine the load step simulation was undertaken. During the simulations the air was injected either into the inlet manifold, compressor or both manifold and compressor also known as two point injection. A parametric study has been undertaken analysing vehicle speed, outlet pressure of the compressor, turbine inlet temperature and driver demand.

It has been observed that the air injection systems improve the transient response of the turbocharger and the overall performance of the engine. The vehicle speed response has been shown to be greatly improved, with the time required for the engine to reach 30kph when air injection is used, reduced by 71% with an additional minor gain for two point injection. These Improvements to the transient performance lead to a significant reduction in engine emissions.

Keywords Two-Point Air Injection, turbocharger, transient response

1 INTRODUCTION

Modern engine developers face the modern challenge of improving vehicle economy and reducing the levels of green house gas emissions. Car manufactures are keen to improve in both these areas. In Europe through the ACEA agreement manufactures have agreed to meet a new vehicle fleet average CO₂ emissions level of 140g/km. Also European Union has set a new target namely 'Euro V' which automotive manufacturers need to achieve by 2008. This will be followed by 'Euro VI' which will further restrict the outputs of harmful emissions.

Turbocharging is an increasingly popular method of reducing the harmful emissions of an Internal Combustion (IC) engines. A turbocharger utilises energy from the exhaust gases and uses it to pressurise the air at the inlet to the cylinders. This allows for the density of air in the cylinder to be greater than the density of ambient air. This allows more power to be produced for a given size of an engine. It has also been shown that use of turbochargers results in reduction the harmful emissions of an engine.

Turbocharged engines have the disadvantage of poor drivability under transient running conditions. The phenomenon known as "Turbo-lag" is particularly apparent in conditions where a rapid load change is applied at lower engine speeds with rapid acceleration (i.e. standing start or acceleration-gear change in low revs). Quick changes in rack position/accelerator pedal do not result in instantaneous response of the turbocharger and consequently vehicle acceleration. This delay has the side effect of increased harmful emissions and engine efficiency deterioration because of unfavourable air-fuel ratio. Reduced air flow in the combustion chamber while fuel is injected causes inadequate air fuel ratio (i.e. rich mixture) resulting in increased formation of emissions such as particulates, CO, CO₂ and NO_x which contribute to environmental pollution.

In general, the causes of the time delay (turbo-lag) in the transient operation of a turbocharged engine can be classified into three groups: mechanical, thermal and fluid dynamic. The first two are associated with mechanical and thermal inertia of the turbocharger rotor and exhaust manifold respectively and the third cause is fluid-dynamic from the exhaust valve up to the turbine and the compressor outlet to the cylinder.

The present work is focused on improving a turbochargers response. This response is a major problem of turbocharged engines limiting their application for a broader use. A study has been carried out looking at different methods of alleviating these problems. The study analyses transient performance improvement using air injection into the inlet manifold, compressor or both inlet manifold and compressor. In this work, performance of a turbocharged engine system has been computationally simulated using the active method of injecting air into the inlet manifold of the engine.

2 ENGINE MODEL

The engine performance has been numerically simulated within the computer software Ricardo WAVE. The modelling process is divided into different sections. This includes in-cylinder analysis, manifold flow analysis, turbocharger, drive-train and vehicle. The specifications of diesel engine modelled in present investigation are given in table 1. The engine system has a radial turbine and centrifugal compressor as turbocharger components.

In the Ricardo wave package many different processes have been modelled using a number of mathematical as well as empirical models. A brief description of models used in Ricardo wave software is given below.

This model uses the Diesel Wiebe Function for heat release (Heywood1988). This is the most appropriate heat release model as actual heat release profiles were not available. The burn duration over the engine speed range is adjusted using the model parameters. The Wiebe function included an ignition delay model to define the crank angle at which combustion is initiated.

In this model heat transfer is calculated using the Woschni model for convective heat transfer (Heywood 1988). This model assumes simple heat transfer from a confined volume surrounded on all sides by walls representing the cylinder head, cylinder liner, and piston face areas exposed to the combustion chamber.

Friction within the engine is modelled by using Friction Mean Effective Pressure (FMEP). This is used when calculating net output quantities such as Brake Mean Effective Pressure (BMEP) and Brake Horse Power (BHP). The correlation uses maximum pressure and average piston velocity term to calculate hydrodynamic friction and a second mean velocity term to calculate the windage loss factors.

The turbocharger is modelled using the "classic" quasi steady methodology (Ricardo WAVE knowledge centre). In this method the flow through the compressor or turbine has been calculated from steady state compressor or turbine maps at each time step using instantaneous inlet and outlet pressures, temperature and turbocharger speed.

The gear box is modelled as a simple ratio relationship between input and output torques. The loss in torque is calculated by an overall efficiency term and a constant loss term for each gear. The vehicle is modelled as a simple mass to which various accelerating and resistive forces are applied. The closed loop driver demand model is a proportional-integral control. The system controls the engine demand

based upon a vehicle velocity specified by the user. The engine demand is an output from the driver demand model where the vehicle velocity is given as a fraction of overall engine performance. The driver demand is a function of the maximum quantity of fuel that can be injected by the fuel injection system.

To simulate injecting air into the compressor a Simulink model was developed to input an additional torque onto the turbocharger. The model is shown in figure 2. The model is linked to the Ricardo WAVE simulation software. The outputs from the WAVE model are from sensors that give values for compressor torque, turbine torque and engine torque. The additional torque supplied by the air injection system is calculated from previous work (Ledger et al 1973). The torque values were utilised as a time dependant look up table. The torque values are summed and then converted into a compressor rotational velocity. This compressor velocity is used to define the operation of the actuators within the WAVE program.

3 SIMULATION STRATEGY

The transient performance of the engine has been simulated as a rapid gradient change at a constant velocity. The rapid gradient change acts as a rapid increase in the load applied on the engine. The closed loop driver was used for to control the vehicle velocity during the transient operation. The vehicles target velocity was a constant 30kph in fourth gear. The gradient was then increase from a gradient of 0 degrees to a gradient of 5 degrees. This gradient change was performed instantaneously.

Air was injected using three different strategies.

- No air injection
- Air injection into the manifold
- Air injection into the compressor
- Two point air injection, injecting into both the inlet manifold and the compressor

4 SIMULATION RESULTS

To asses the effectiveness of the active air injection system at reducing turbo-lag a parametric study has been carried out. The effectiveness of the system has been evaluated by monitoring variation of four parameters. The 4 parameters used to study this effect are compressor outlet pressure, turbine inlet temperature, driver demand and vehicle velocity. Compressor outlet pressure indicates the turbochargers output and the turbine inlet temperature is an indicator for how much energy is supplied to the turbocharger system. The Driver demand parameter was used to show how the control system was operating during the transient period. The vehicle speed was used to analyse the overall vehicle performance. The brake torque parameter was used to asses the response of the engine.

The effect of the different air injection strategies upon compressor outlet pressure is shown in figure 3. When the air injection system is not in operation the outlet pressure from the compressor rises at a steady rate to a steady state at a pressure of 1.15bar. When the air injection system is activated there is an initial rapid increase in compressor outlet pressure which then increases steadily until the air injection system is deactivated. At this point the compressor outlet pressure falls to a steady state of 1.15bar. The time to reach the steady state value when no air injection was used was 23 seconds. When the air injected into the inlet manifold the time was reduced by 95%. Injection into the compressor has been shown to have a marginally slower response of that to injecting into the inlet manifold. The twin point injection shows a marginal response improvement over injection into the inlet manifold.

The turbine inlet temperature response is shown in figure 4. The Turbine inlet temperature responds in a very similar way to the driver demand. As driver demand increases the temperature output from the engine increases proportionally. This is because the driver demand is directly related to the engine fuelling. When no air was injected the time period for the turbine inlet temperature to reach a steady state is 15 seconds. When air was injected for 3 seconds the time period for the turbine inlet temperature was reduced by 33%. Injection into the compressor and twin point injection show that it takes a longer time period to reach steady state. This is because the driver demand is greatly decreased because of the over-shoot in vehicle velocity.

The driver demand is shown in figure 5. This figure shows the closed loop driver output. Initially the driver demand increases rapidly to 100%. The driver demand then stays at 100% for 4 seconds before decreasing to a steady state demand of 90%. When the air was injected into the inlet manifold the driver demand rises sharply to a peak of 98% before falling immediately until the air injection system is deactivated. The driver demand then increases to the steady state value of 90%. The demand falls below the steady state value when the air injection system is in operation because the vehicle speed has increased to above the required 30kph. The demand was reduced by closed loop driver control system.

The affect of air injection on vehicle velocity is depicted in figure 6. The figure shows that as the load is applied to the engine when there is no air injection the vehicle speed decreases rapidly. After an initial drop the vehicle velocity then increases to over 30kph before decelerating to a steady state value of 30kph. When the air injection strategies are used the time for the vehicle speed to increase to over 30kph is reduced greatly. The time taken for the vehicle to initially return to 30kph when no air injection was used was calculated to be 10.5 seconds. When the air was injected into the inlet manifold the time taken to initially return to 30kph was 3 seconds. The air injection system improved the response by 71%. Small improvements were shown when injecting into the compressor or using the twin point injection.

5 CONCLUSION

This paper shows a modelling technique to simulate effects of different air injection strategies on the engine performance. The initial results show that all the air injection strategies simulated considerably reduces turbo-lag in IC engines.

1. Air injection significantly improves the transient engine performance.
2. Two point injection improves transient response by the greatest margin.

REFERENCES

GILKES O. S., MISHRA R, FIELDHOUSE J, RAO V (2007) "*Effectiveness of Active and Passive Transient Reduction Methods used in Turbocharged Engine Systems*", EAEC 2007 Budapest, AE10-4

LEE C., CHOI L., (2002) "*Effect of air injection on the characteristics of transient response in a turbocharged diesel engine*", Int. J. Therm. Sci. 41, 63-71

MATSURA Y., NAKAZAWA N., KOBAYASHI Y., OGITA H., KAWATANI T., (1992) "*Effects of Various Methods for Improving Vehicle Startability and Transient Response of Turbocharged Diesel Trucks*", SAE Paper 920044

LEDGER J., BENSON R., FURUKAWA H., (1973) "*Improvement in Transient Performance of a Turbocharged Diesel Engine by Air Injection into the Compressor*", SAE Paper 730665

HEYWOOD J., (1988) "*Internal combustion engine fundamentals*", McGraw-Hill, ISBN 007028637x

Ricardo WAVE Knowledge Centre

Engine Type	4 Stroke Diesel
Bore	85.0mm
Stroke	88.0mm
Number of Cylinders	4
Combustion System	Direct Injection
Compression Ratio	19.5
Gear Ratio in 4 th gear	37/32

Table 1: Engine Data

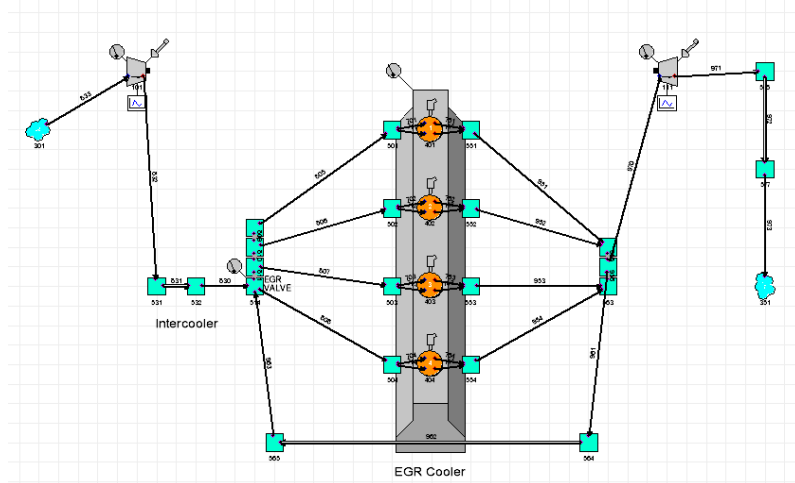

Figure 1: Engine Model

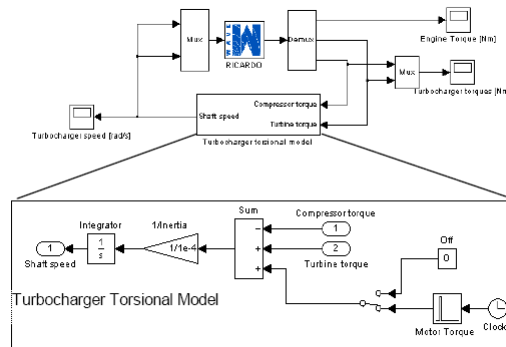

Figure 2: Compressor Injection Model

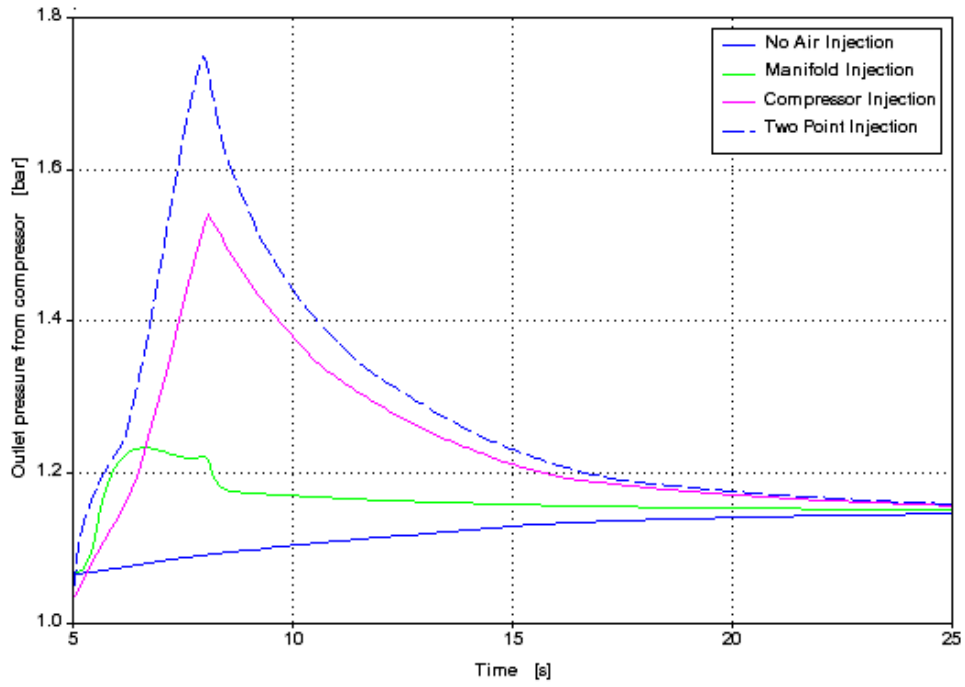

Figure 3: Vehicle Speed Response

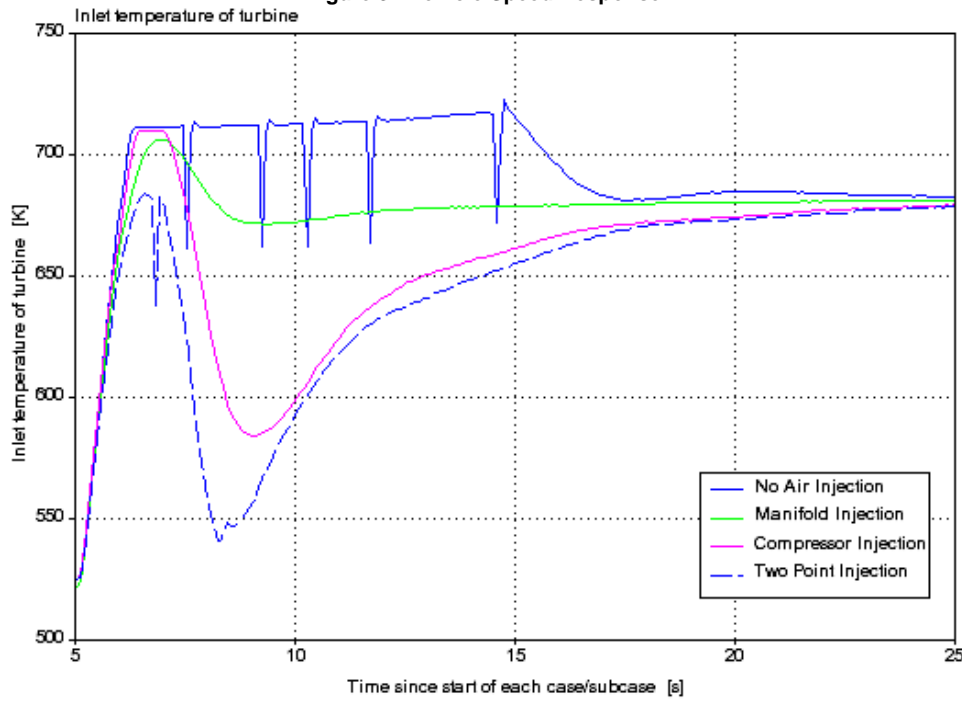

Figure 4: Turbine Inlet Temperature Response

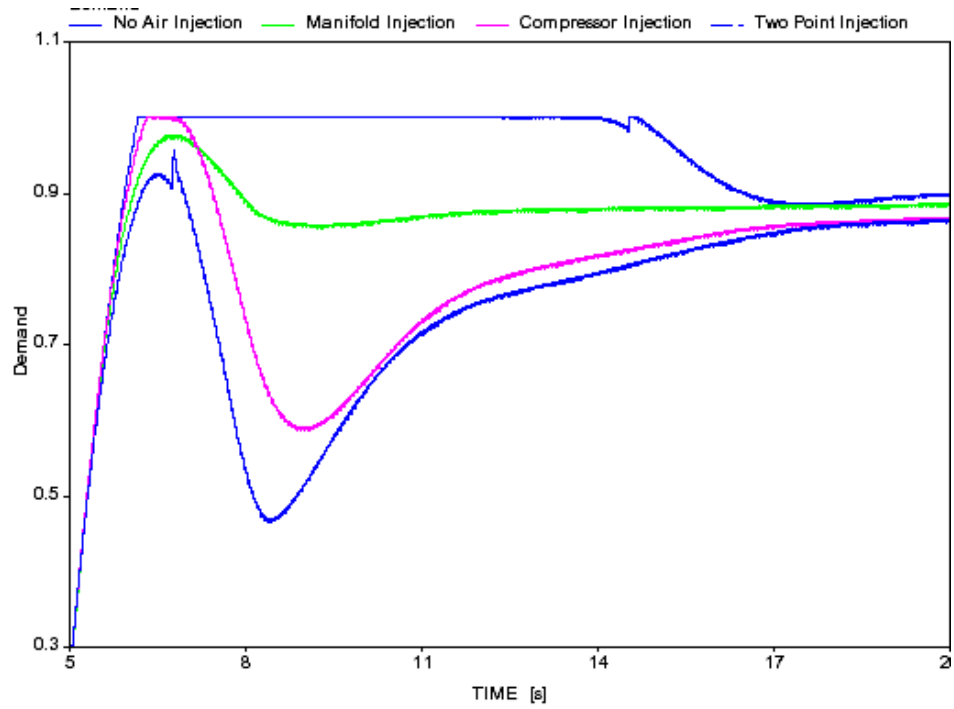

Figure 5: Driver Demand Required

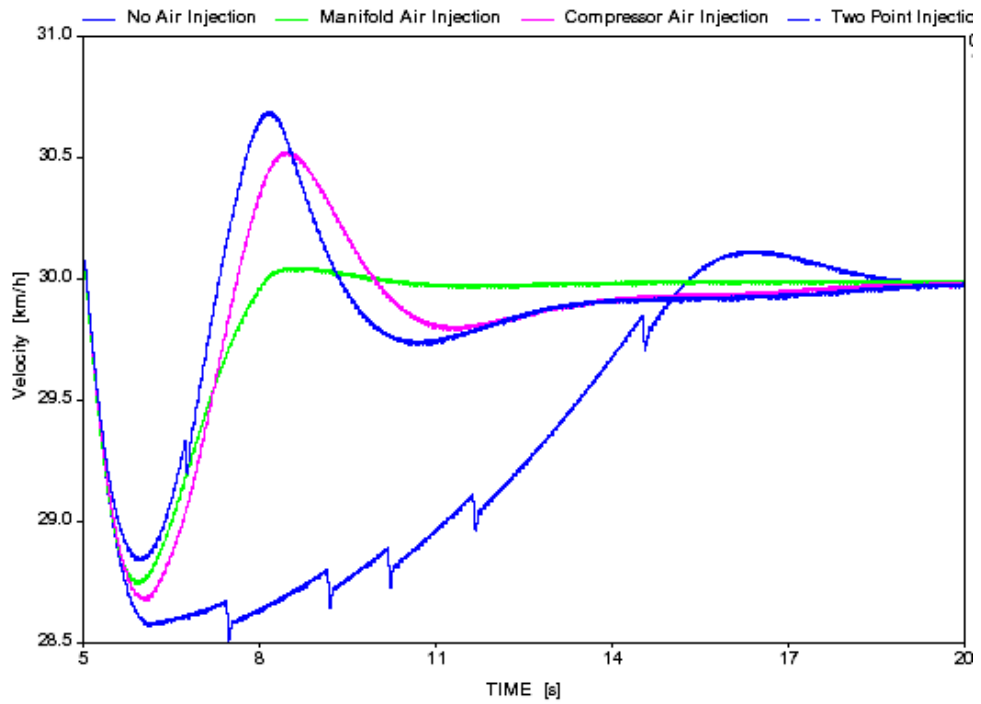

Figure 6: Vehicle Velocity Response