

Heating System Water Flow Rate Prediction Using Three Port Control Valves

Authors: Dr. J.S. Edge and Dr C.P. Underwood, School of the Built Environment,
University of Northumbria.

Summary

This work highlights the requirement for flow rate measurement in order to monitor energy use in heating systems. It recognises that not all heating systems have the facility to monitor system water flow rates. It investigates, via a test facility, the combined port flow characteristics of three port valves and fits mathematical equations to them. The paper then goes on to test the validity of the use of these relationships in the prediction of system water flow rates in practice. The work finds that there is considerable potential in using three port valves for 'passive flow monitoring'.

List of Symbols

f = flow ratio

\dot{V} = circuit volume flow rate (m^3/s)

\dot{V}' = circuit volume flow rate at design conditions (m^3/s)

1.0 Introduction

Energy monitoring is an important feature in the running of buildings today. A number of methods are used to monitor energy use in buildings. With respect to heating systems one way to monitor energy use is to measure water flow rates and flow and return water temperatures over time. These could then be used in a simple energy balance equation to give energy use. Indeed, Haberl and Watt¹ state that “flow measurement is an important part of the analysis of building energy use whenever thermal energy use is being investigated.” Flow and return water temperature monitoring is a normal function of a Building Energy Management System (BEMS). Water flow rates can be measured by a flow meter. A wide range of flow meters are available today with varying degrees of accuracy and reliability. Indeed Babus’Haq et al², when looking at the performance of heat meters, stated that “the measurement of flow rate causes by far the most significant uncertainty in the overall accuracy, despite the fact that the flow unit is the most expensive component of the heat meter.”

The capital costs and installation requirements of these flow meters may lead to the exclusion of them in the final installed system, particularly where cost cutting during the system design period is required.

Haberl and Watt¹ reinforce this view by stating that “unfortunately, the need for accurate measurement is often stifled . . . due to tight budget constraints where the building owner may not be willing to pay the additional . . . cost for the detailed measurement . . .”.

Surveys of many existing buildings serviced by conventional hot water heating and chilled water cooling reveal that all of the energy utilised usually passes at some stage through a modulating control valve. Valve position data is a normal function of a BEMS control algorithm (where control signals are calculated centrally), or is detectable (i.e. if local autonomous control is used where stand alone controllers are used at plant level, which communicate with the BEMS host). This paper investigates the possibility of using the control signals of these valves (from BEMS) together with the measured combined port flow characteristics of three port valves to predict system water flow rates, negating the requirement of separate flow metering equipment.

1.1 Background

Three-port valves are widely used in building services engineering applications. They may have either two inlet ports and one outlet port (mixing), or one inlet port and

two outlet ports (diverting). Both these types of valve may be used in mixing or diverting applications depending on their pipe work connections. They can provide either constant temperature variable flow control or variable temperature constant flow control. CIBSE³ point out that most of the three-port valves used in building services engineering have two inlet ports and one outlet port.

The relationship between the position of the valve stem and the corresponding flow rate passed by the valve is called the valve characteristic. Valves are manufactured with a certain inherent characteristic which describes this relationship whilst a constant pressure drop is achieved across the valve. This is an ideal characteristic of the valve which expresses its performance without the influence of the associated pipe work system pressure fluctuations in which it is installed. A large range of inherent characteristics are available. For three-port valves the choice of inlet port (i.e. the port connected to the load) characteristic is normally governed by the 'non-linear' relationship between flow and heat emission of most heat exchange devices. The chosen characteristic offsetting this 'non-linear' characteristic in order to achieve an overall linear relationship between valve stem position and heat emission of the device. The bypass port characteristic is chosen to achieve a constant total flow through the valve at all valve stem positions. This, however, is rarely achieved in practice.

Little work has been carried out to document the combined port flow rate performance of three port control valves. It is this knowledge of combined port outlet flow rate, as governed by the installed characteristics of a valve, that has been identified for the possible use in flow rate monitoring as an alternative to conventional flow measuring techniques. Specifically, the degree to which the three-port valve maintains a constant flow in the non-controlled part of the circuit, and at what fraction of design circuit flow this is maintained. The information obtained may then be used to consider how adequate a knowledge of the valve control signal would be in the monitoring of flow conditions in cases where conventional flow metering is impracticable or considered prohibitively expensive. Such a knowledge would provide a simple and low cost method of monitoring energy use in circuits equipped with control valves themselves positioned from signals processed in building management and computer-based control systems. It should be noted that, at this stage, this investigation uses relatively new valves for study and that factors such as valve wear, erosion, or build-up of deposits have not been taken into account.

2.0 Detailed Investigation

In order to carry out this investigation an experimental test facility was developed. The test rig was specifically designed to study the installed outlet port characteristic of the valve. The effect of the interaction of a pipe work system with a valve had to be assessed. When selecting a control valve, the valve authority takes these pressure drop characteristics into account by relating them to the pressure drop across the control valve. In order to investigate the influence of valve authority, the rig was designed with the facility to regulate the pressure drop across the flow controlled part of the circuit. Thus the installed valve authority was adjustable so that the effect of valve authority and hence differing system pressure drops were able to be studied. Typically, valve authorities of 0.3 - 0.75 were chosen, to represent a range consistent with what might be expected in practice (ref. CIBSE³ and Letherman⁴).

Referring to figure 1 the design layout for the rig was chosen so that the three port control valve was connected as would be the case for a typical, mixing/injection circuit application commonly used to convert medium/high temperature hot water to low temperature hot water for use in heating systems. The same configuration is also applicable for a compensated heating system and indeed is used commonly in building services applications. The position of the three port control valve in both these circuit configurations is an ideal point of assessment of energy use as all of the heating water associated with the controlled circuit will travel through this valve.

Figure 1: Test rig schematic

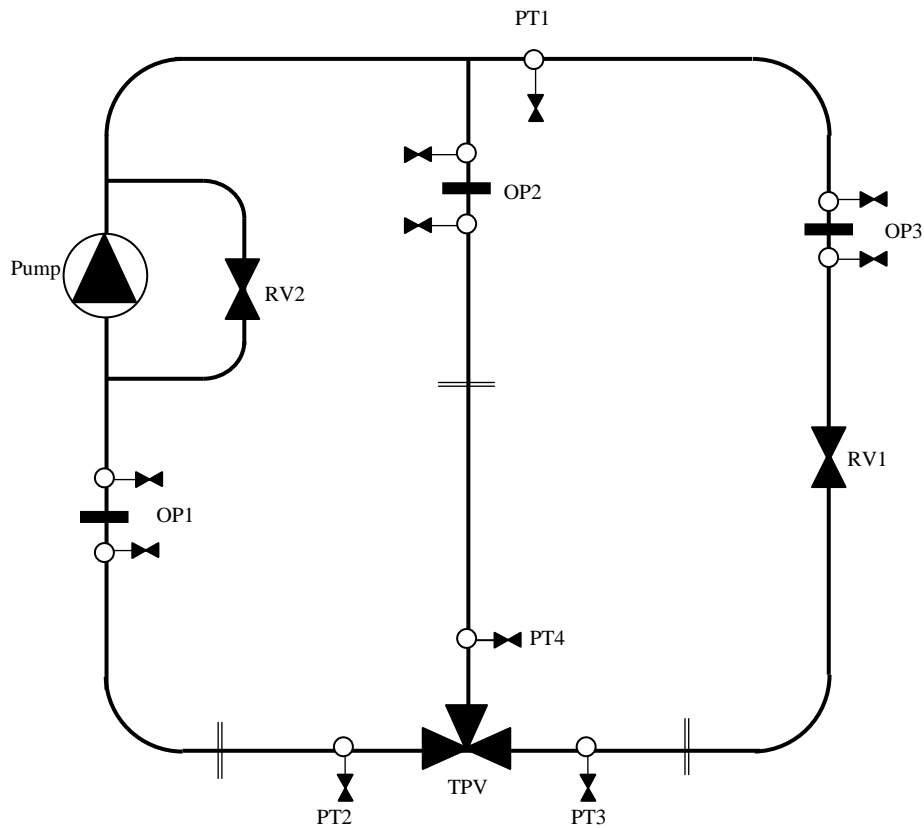

Key:	RV	regulating valve
	PT	pressure tapping
	OP	orifice plate
	TPV	three-port valve

A range of pneumatically actuated three-port control valves were donated by an established valve manufacturer. Specifically, four valves were tested - 40mm, 50mm, 65mm and 80mm nominal bore screwed cast iron valves. Pneumatic diaphragm actuators were supplied with the valves. Valve stem position was monitored from a pointer on the valve stem and a graduated scale on the valve actuator. Each of the valves had a standard configuration of two inlet ports and one outlet port. The inherent characteristics of each of the two inlet ports on the valves were linear. All valves had a let-by rate of 0.05% of design rated flow. The valves were installed in the rig for testing according to British Standard 5793 : 1981⁵. The test rig was built using welded mild steel tube with a nominal bore diameter of 80mm in order to accommodate the largest valve under test. All the orifice plates were built and

installed according to British Standard 1042⁶. A mercury filled ‘U’ tube manometer was used to monitor the pressure difference across each of the orifice plates. An 80mm nominal bore regulating valve RV1 was installed in the fixed pipe work in a position such that it could be used to adjust the pipe work system resistance in the controlled part of the circuit. Thus the valve authority could be adjusted. To calculate valve authority, the pressure drop across the valve and the pressure drop across the varying flow rate part of the circuit had to be measured. The pressure drops were measured by mercury ‘U’ tube manometers. Values of 0.3, 0.5 and 0.75 for valve authority were typically used for each test valve.

3.0 Results

Results were plotted of flow ratio versus normalised control signal as a series of line and symbol graphs to represent installed combined port flow rate characteristics for each valve at different valve authorities. Flow ratio defined in this case as;

$$f = \frac{\dot{V}}{\dot{V}'} \dots\dots\dots(1)$$

Referring to the graphs in figures 2 - 13, results for the combined plots of the upward and downward stroke flow characteristics at all valve authorities, for each valve, demonstrating the effect of valve authority on the installed flow characteristics of the valve.

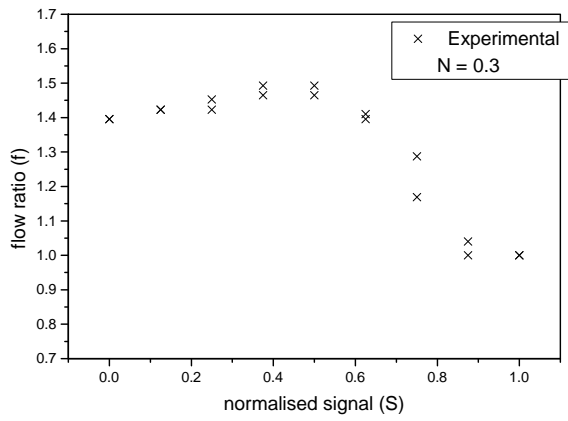

Fig.2 : 40mm valve, initial results

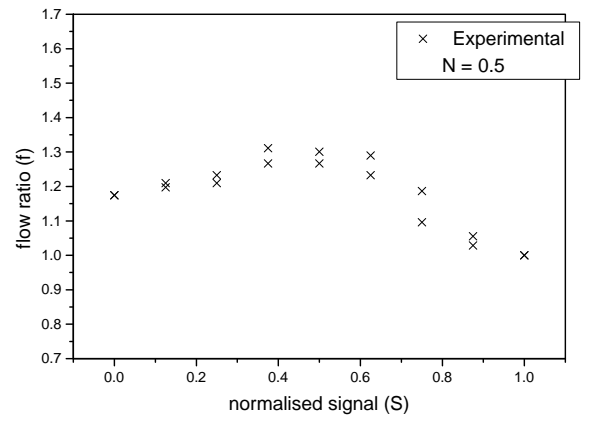

Fig.3 : 40mm valve, initial results

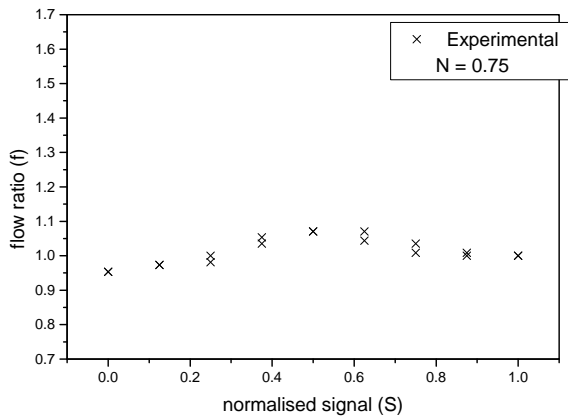

Fig.4 : 40mm valve, initial results

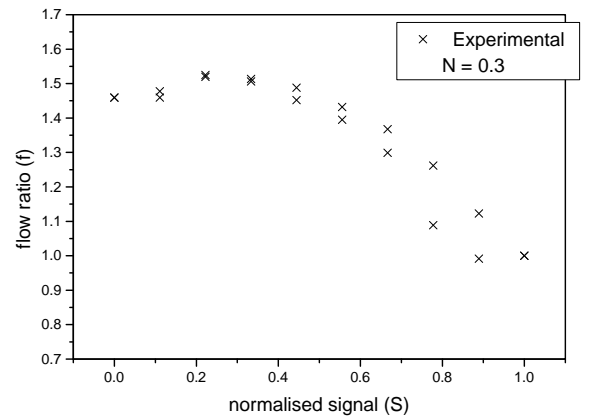

Fig.5 : 50mm valve, initial results

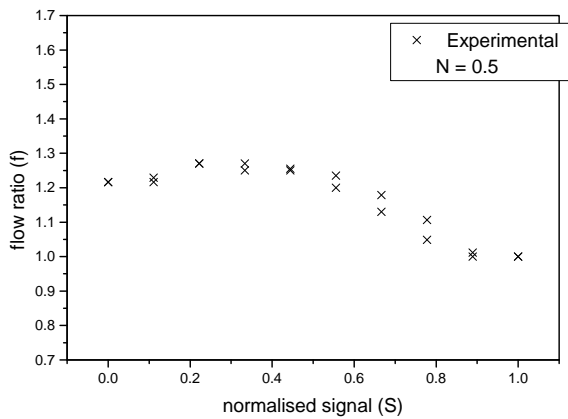

Fig.6 : 50mm valve, initial results

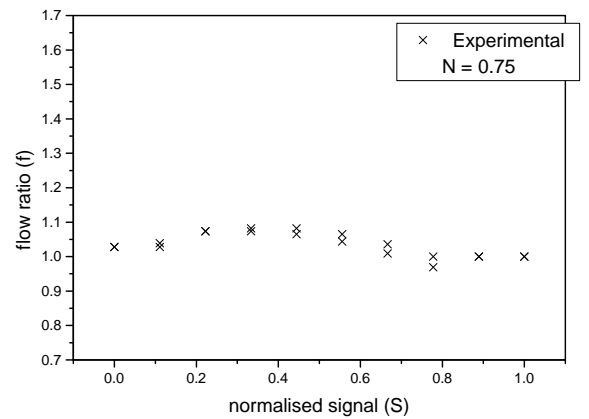

Fig.7 : 50mm valve, initial results

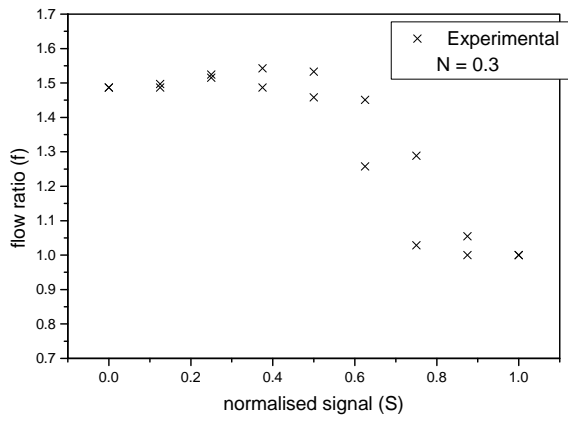

Fig.8 : 65mm valve, initial results

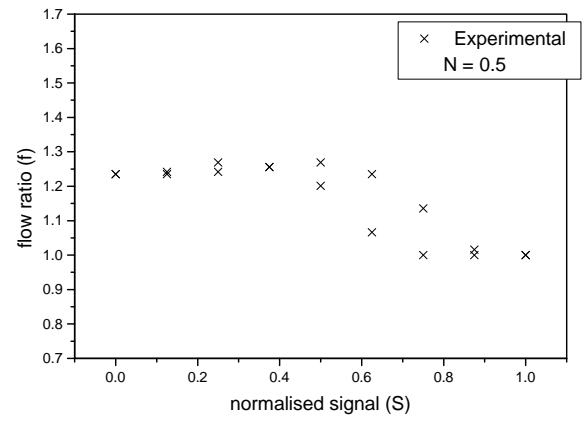

Fig.9 : 65mm valve, initial results

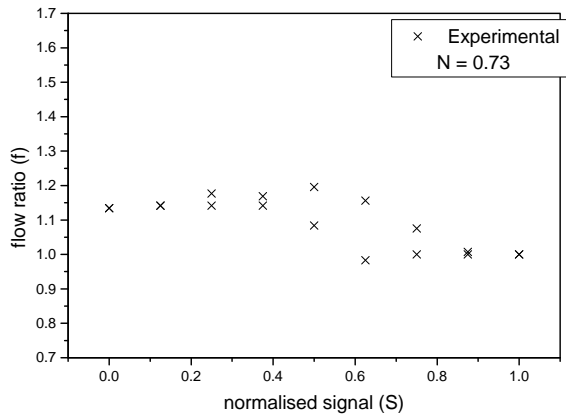

Fig.10 : 65mm valve, initial results

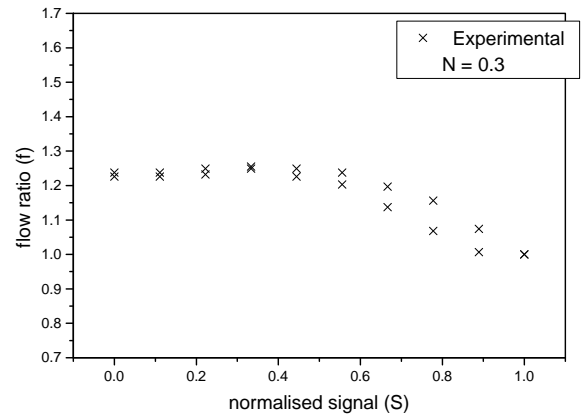

Fig.11 : 80mm valve, initial results

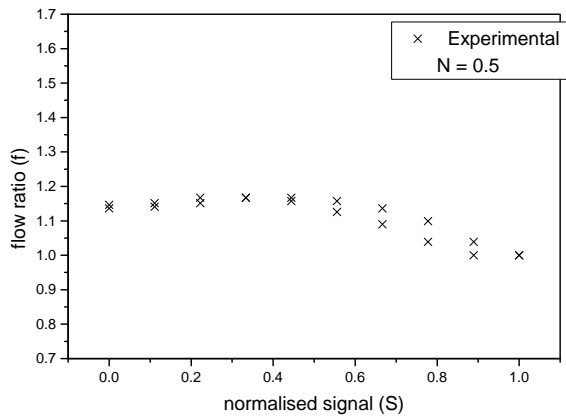

Fig.12 : 80mm valve, initial results

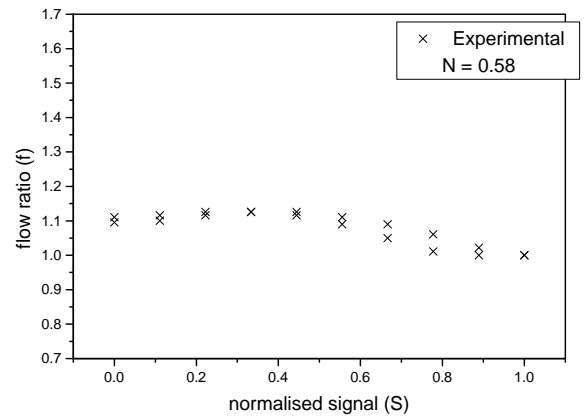

Fig.13 : 80mm valve, initial results

Referring to figures 2 - 13, it can be seen that a constant combined port outlet flow rate is not achieved for any of the valves, with the majority of flow ratio values being in excess of unity, i.e. the design flow at fully open inlet port valve position. The deviance in actual to design flow rate tends to reduce with increasing valve authorities.

4.0 Validation of Results

In order to test the validity of the results the test rig was modified. In order to incorporate these relationships into an energy use algorithm a series of mathematical curve fits to the flow/control signal relationships are made using polynomial regression analysis.

4.1 Modification of Test Rig

The original test rig used a manual adjustment of control signal to the actuator of the control valve via a regulating valve on the air line from the compressor to the final control element. The air pressure signal was monitored on a pressure gauge by visual inspection. A visual inspection of a mercury manometer allowed the differential pressure across the combined flow orifice plate to be evaluated.

In most heating systems today, monitoring and control is carried out by a Building Energy Management System (BEMS). Indeed, it is normally the task of the BEMS to issue control commands to control valves within the building services engineering systems. One of the ways in which this is done is by the output of an analogue signal, usually in the range of 4 - 20mA or 0 - 5Vd.c. via a transformer. In order to simulate a BEMS control signal, a stabilised power supply was used to give a variable analogue output d.c. current over a range of 4 - 20mA. In order to convert this electrical control signal to a proportional pneumatic control signal an electro-pneumatic transducer was used. In order to monitor the test valves combined outlet port flow rate automatically, the mercury manometer for the combined flow orifice plate (OP1) was replaced by a differential pressure transmitter. Data acquisition from the modified test rig was carried out by a data logger.

4.2 Mathematical Curve Fitting

In order to investigate the possibility of incorporating the flow/control signal relationships into a Building Energy Management (BEMS) function, mathematical

expressions were generated to describe the relationships using regression calculations in a commercially available software package. This package has a built-in least squares regression function. Because the measured result plots were of a curvilinear form a polynomial regression was considered to be appropriate. In order to represent the measured data as accurately as possible, a separate polynomial regression least squares analysis was carried out for each upward and downward stroke for each test valve at each valve authority.

4.3 Curve fitting Results

The polynomial models were represented as curvilinear plots on two-dimensional graphs. The empirical data were plotted on the same axes of the same graphs so that comparisons could be made. Fifth order polynomial expressions were found to give a satisfactory fit for all the data curves. Referring to figures 14 - 29 for the graphical comparisons it can be seen that good correlation between measured data and curve fit data was achieved. Coefficients of determination (R^2) values were given for all the polynomial regressions. These ranged from a minimum value of 0.987 to a maximum value of 0.999 indicating the quality of fit of the regression model. See Table 1 for a summary of R^2 values.

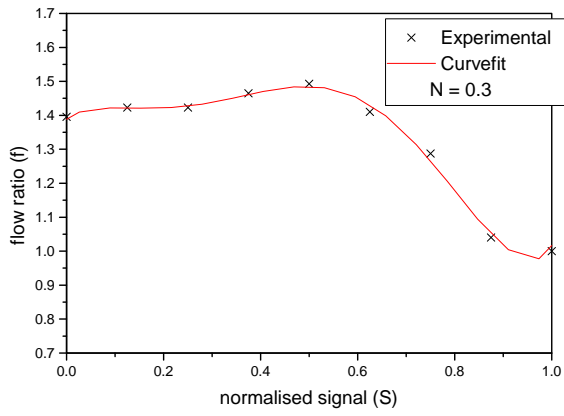

Fig.14 : 40mm valve, upstroke

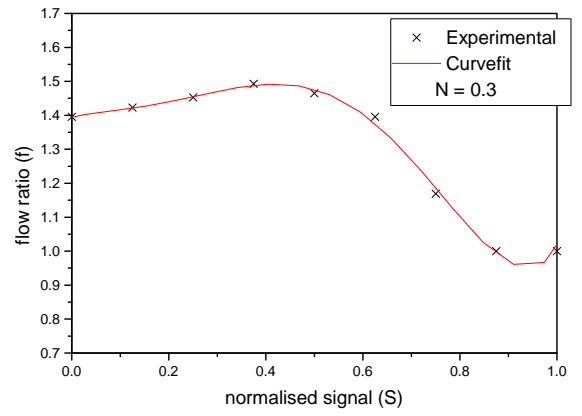

Fig.15 : 40mm valve, downstroke

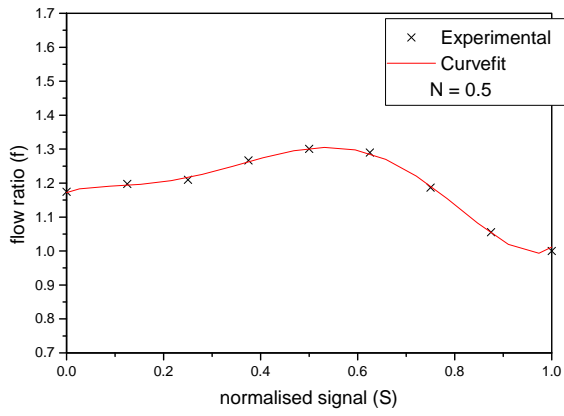

Fig.16 : 40mm valve, upstroke

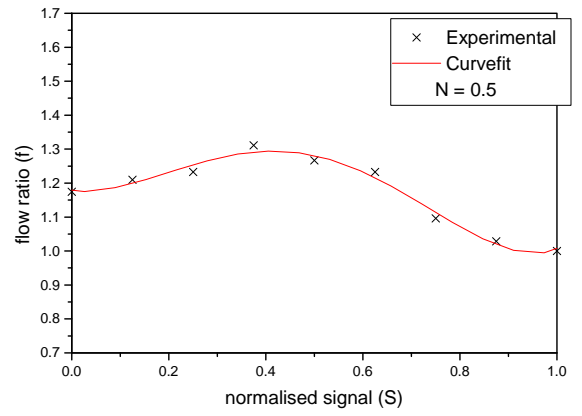

Fig.17 : 40mm valve, downstroke

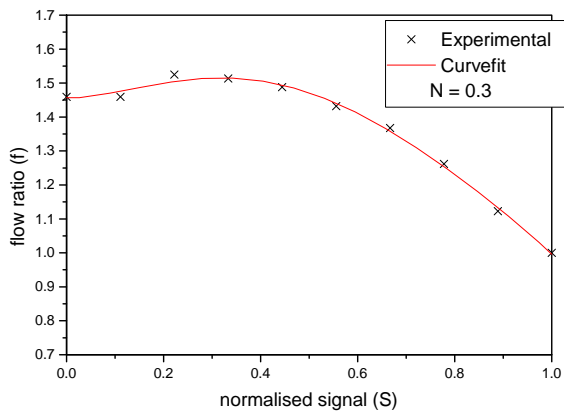

Fig.18 : 50mm valve, upstroke

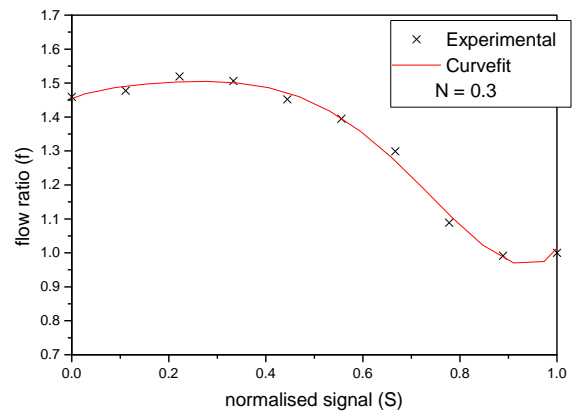

Fig.19 : 50mm valve, downstroke

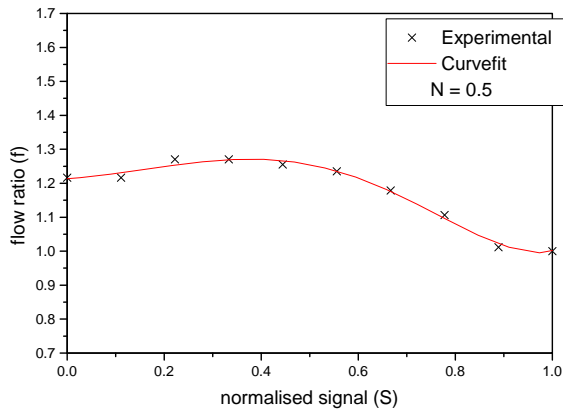

Fig.20 : 50mm valve, upstroke

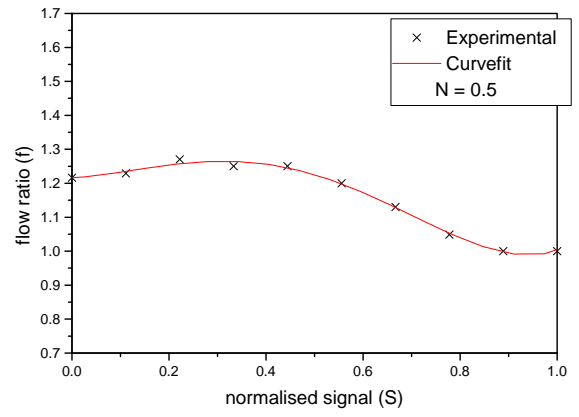

Fig.21 : 50mm valve, downstroke

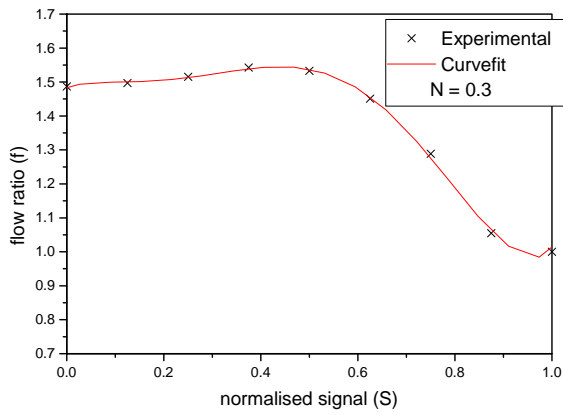

Fig.22 : 65mm valve, upstroke

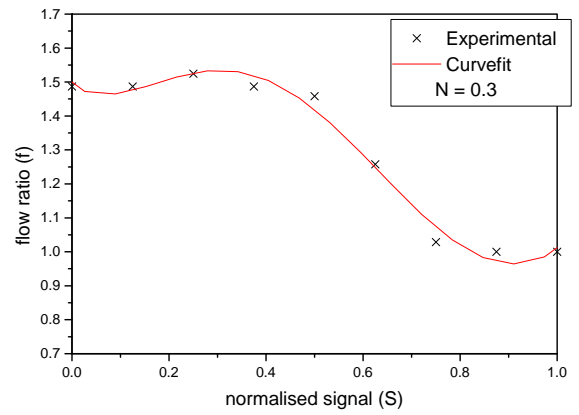

Fig.23 : 65mm valve, downstroke

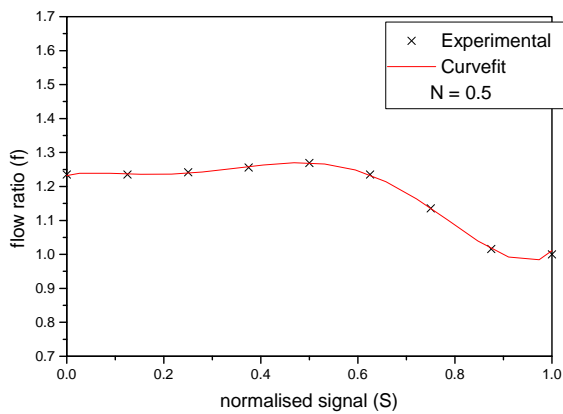

Fig.24 : 65mm valve, upstroke

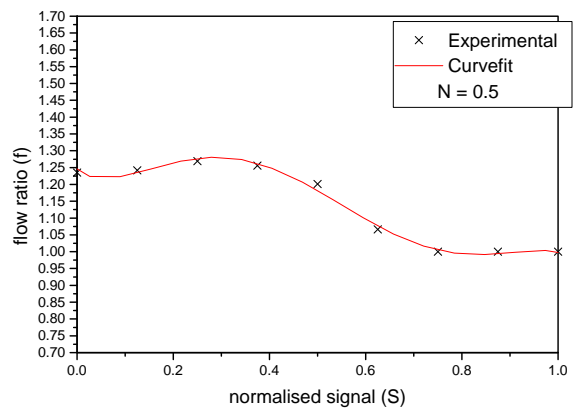

Fig.25 : 65mm valve, downstroke

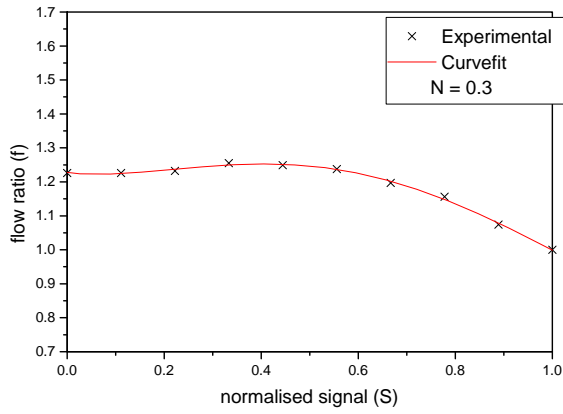

Fig.26 : 80mm valve, upstroke

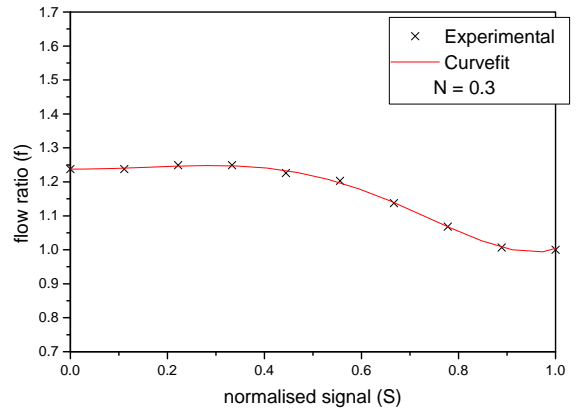

Fig.27 : 80mm valve, downstroke

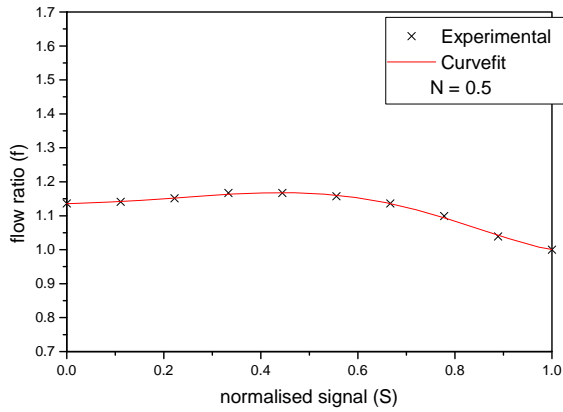

Fig.28: 80mm valve, upstroke

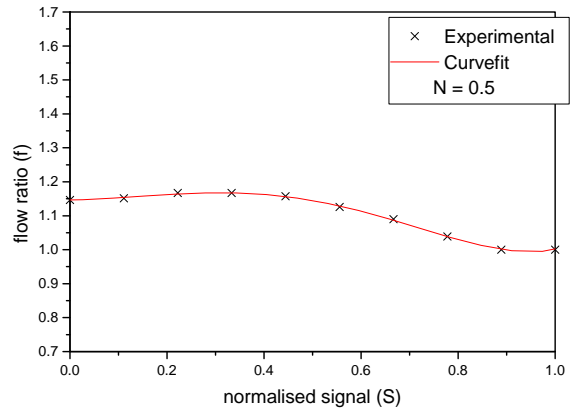

Fig.29 : 80mm valve, downstroke

Table 1: Comparison of R^2 values

Valve	R^2_{fitted} (Upstroke)	R^2_{fitted} (Downstroke)	R^2_{fitted} (Average)
80mm (N = 0.3)	0.99867	0.99943	0.99905
80mm (N = 0.5)	0.99884	0.99955	0.99919
65mm (N = 0.3)	0.99961	0.99329	0.99645
65mm (N = 0.5)	0.99987	0.99686	0.99836
50mm (N = 0.3)	0.9981	0.99719	0.99764
50mm (N = 0.5)	0.99537	0.99777	0.99657
40mm (N = 0.3)	0.99795	0.99858	0.99826
40mm (N = 0.5)	0.99931	0.98988	0.99459

4.4 Results Comparison

The results from the modified validation test rig were plotted on graphs of flow ratio versus normalised control signal for each test valve, at each valve authority. The control signal values from the modified test rig were used as an input to the polynomial regression equations in order to achieve corresponding predicted flow ratio values. These relationships were plotted on the same graphs so that a comparison could be made. Referring to figures 30 - 37 for these graphs, and also to Table 2 which summarises the results.

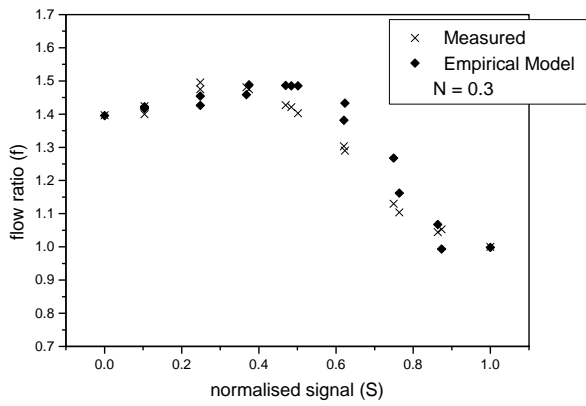

Fig.30: 40mm valve, comparison between measured flow ratios and predicted flow ratios from empirical model.

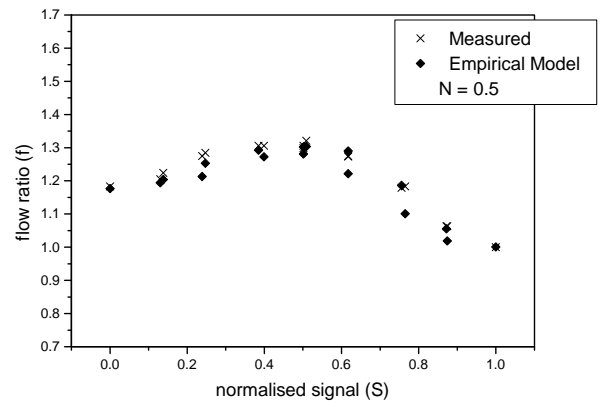

Fig.31: 40mm valve, comparison between measured flow ratios and predicted flow ratios from empirical model.

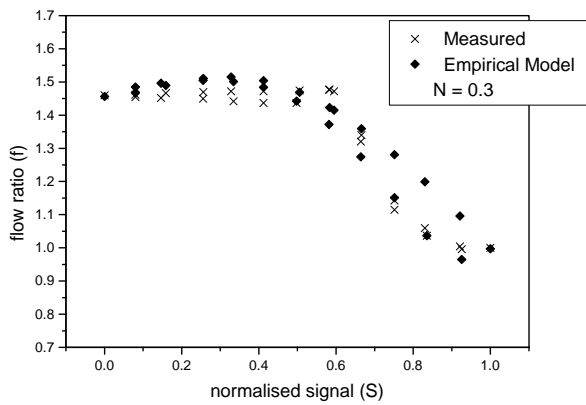

Fig.32: 50mm valve, comparison between measured flow ratios and predicted flow ratios from empirical model.

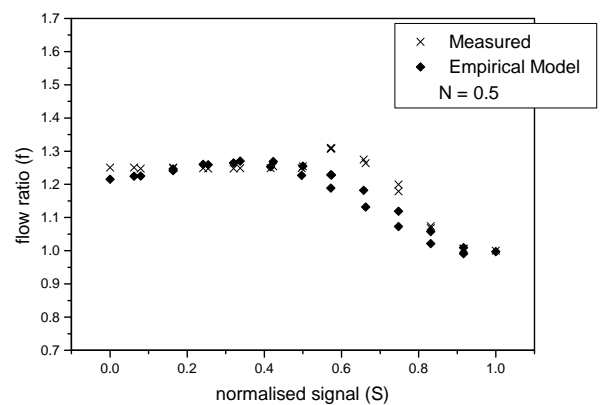

Fig.33: 50mm valve, comparison between measured flow ratios and predicted flow ratios from empirical model.

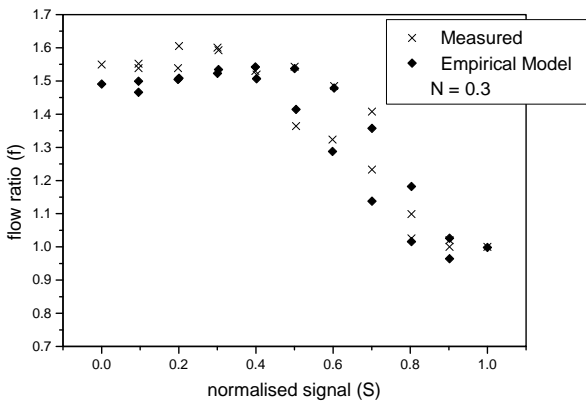

Fig.34: 65mm valve, comparison between measured flow ratios and predicted flow ratios from empirical model.

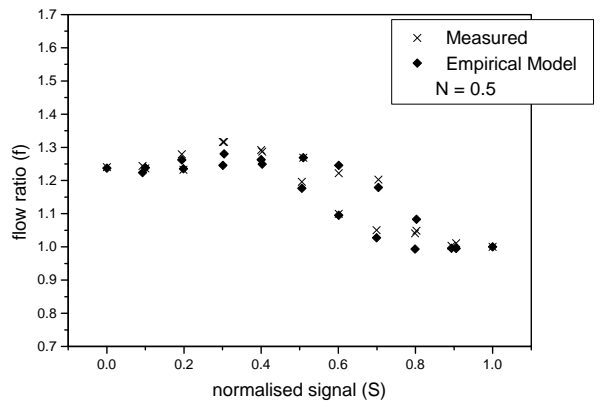

Fig.35: 65mm valve, comparison between measured flow ratios and predicted flow ratios from empirical model.

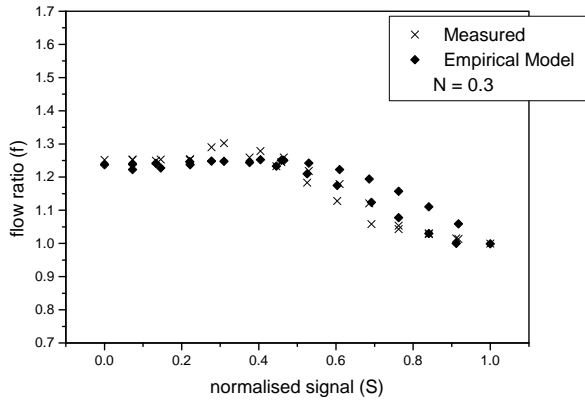

Fig.36: 80mm valve, comparison between measured flow ratios and predicted flow ratios from empirical model.

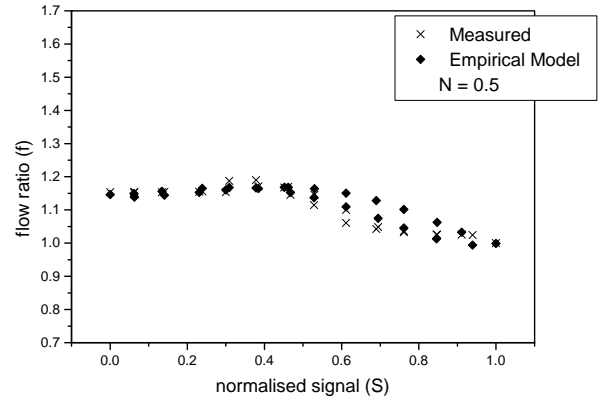

Fig.37: 80mm valve, comparison between measured flow ratios and predicted flow ratios from empirical model.

Table 2: Summary of prediction errors

Valve	Maximum Over Prediction Error	Maximum Under Prediction Error	Average Prediction Error	RMS Error
80mm (N = 0.3)	+9.81%	-4.17%	+1.071%	4.03%
80mm (N = 0.5)	+8.23%	-2.93%	+0.941%	2.86%
65mm (N = 0.3)	+7.56%	-7.71%	-1.81%	5.29%
65mm (N = 0.5)	+3.30%	-5.37%	-1.19%	2.73%
50mm (N = 0.3)	+13.13%	-7.11%	+1.74%	5.85%
50mm (N = 0.5)	+3.73%	-8.77%	-0.62%	4.66%
40mm (N = 0.3)	+12.19%	-5.6%	+2.347%	6.54%
40mm (N = 0.5)	+1.19%	-6.97%	-1.825%	3.36%

The above detailed RMS errors range from 2.73% to 6.54% and were encouragingly low, though higher errors did occur at individual control signals.

5.0 Conclusions

This work has investigated the relationship between the incoming control signal to a valve and its combined port flow ratio. It has shown that, for valves that can be tested, a mathematical equation can be fitted to the flow ratio profile and that this equation can be used in conjunction with control signal values to predict the combined port flow rates in a pipe work system. This test data will possibly be available from manufacturers. Failing this, test results are relatively easy to obtain in laboratory conditions. The control signal data will generally be available in cases where the various control systems are under computer-based control, or a building

management system is in use. These predictions can take into account the system resistance by specifying the authority (N) of the valve. Validation results demonstrate that the average RMS errors for these curve fit equations range between 2.73% to 6.54%. Therefore, for a fully modulating control valve in practice, prediction of combined port flow ratios by these empirical models is very good compared to some flow meter performances.

In summary it would be no great hardship for manufacturers to test all their valves in a similar manner to the test performed within this work. A simple test rig with valve authority adjustment is all that is required. A new British Standard could be written for valve testing to set out this form of test so that manufacturers could supply their valves as 'energy station calibrated'. This would mean that valves could be supplied with flow ratio signatures included in the manufacturers data for the valves, perhaps for a number of common valve authorities. These flow ratio signatures could be used within BEMS to predict combined port flow rates.

References

1. Haberl, J., Watt, J. Thermal energy measurement with tangential paddle wheel flow meters. Solar Engineering, vol. 12. ASME 1995.
2. Babus'Haq, R.F., Overgaard, G. and Probert, S.D., Heat-Meter Developments for CHP-DH Networks, Applied Energy, Volume 53, Issues 1-2, 1996, Pages 193-207.
3. CIBSE Guide. Volume B. Installation and Equipment Data. 1986.
4. Letherman, K.M. Automatic Controls for Heating and Air Conditioning: principles and applications. Oxford: Pergamon, 1981.
5. British Standards, BS5793 : Industrial Process Control Valves, Parts 1 and 2, London : British Standards Institution, 1989.
6. British Standards, BS1042 ; Methods of Measurement of Fluid Flow in Closed Conduits, London : British Standards Institution, 1989.