



**CHALMERS**  
UNIVERSITY OF TECHNOLOGY

## **Synthetic biology tools for environmental protection**

Downloaded from: <https://research.chalmers.se>, 2023-10-28 13:46 UTC

Citation for the original published paper (version of record):

Aminian-Dehkordi, J., Rahimi, S., Golzar-Ahmadi, M. et al (2023). Synthetic biology tools for environmental protection. *Biotechnology Advances*, 68.

<http://dx.doi.org/10.1016/j.biotechadv.2023.108239>

N.B. When citing this work, cite the original published paper.



Research review paper

## Synthetic biology tools for environmental protection

Javad Aminian-Dehkordi<sup>a</sup>, Shadi Rahimi<sup>b</sup>, Mehdi Golzar-Ahmadi<sup>c</sup>, Amritpal Singh<sup>d</sup>,  
Javiera Lopez<sup>d</sup>, Rodrigo Ledesma-Amaro<sup>d,\*,\*\*</sup>, Ivan Mijakovic<sup>b,e,\*</sup>

<sup>a</sup> Department of Bioengineering, University of California, Berkeley, USA

<sup>b</sup> Department of Life Sciences, Chalmers University of Technology, Göteborg, Sweden

<sup>c</sup> Norman B. Keevil Institute of Mining Engineering, University of British Columbia, Vancouver, Canada

<sup>d</sup> Department of Bioengineering, Imperial College London, London, SW72AZ, UK

<sup>e</sup> Novo Nordisk Foundation Center for Biosustainability, Technical University of Denmark, Lyngby, Denmark



### ARTICLE INFO

#### Keywords:

Bioremediation  
Synthetic biology  
Engineering  
Biosensor  
Phytoremediation

### ABSTRACT

Synthetic biology transforms the way we perceive biological systems. Emerging technologies in this field affect many disciplines of science and engineering. Traditionally, synthetic biology approaches were commonly aimed at developing cost-effective microbial cell factories to produce chemicals from renewable sources. Based on this, the immediate beneficial impact of synthetic biology on the environment came from reducing our oil dependency. However, synthetic biology is starting to play a more direct role in environmental protection. Toxic chemicals released by industries and agriculture endanger the environment, disrupting ecosystem balance and biodiversity loss. This review highlights synthetic biology approaches that can help environmental protection by providing remediation systems capable of sensing and responding to specific pollutants. Remediation strategies based on genetically engineered microbes and plants are discussed. Further, an overview of computational approaches that facilitate the design and application of synthetic biology tools in environmental protection is presented.

### 1. Introduction

According to a recent World Health Organization (WHO) report, environmental risk factors cause approximately 25% of human deaths, corresponding to 12.6 million yearly deaths (Prüss-Ustün et al., 2017). Various types of environmental pollutants are often widely dispersed and difficult to identify and locate. For most pollutants, there is a lack of cost-effective remediation techniques. Synthetic biology holds a promise of delivering new tools for pollution monitoring and effective and targeted remediation (Reynolds, 2021).

Human industrial activities on the ground, oil spills, unrestrained use of plastics, and landfilling of hazardous waste like electronic waste have resulted in a massive release of different pollutants such as heavy metals, polychlorinated biphenyls (PCBs), polyaromatic hydrocarbons (PAHs), volatile organic carbons (VOCs), and polybrominated biphenyls (PBBs) into soil and sediments. Major contaminants such as persistent organic pollutants (POPs) can find their way into our food chain and health system through poisoned agricultural products since they are absorbed

more quickly into solid particles than dissolving in water (Li, 2018). More importantly, the growing global population and food demand underscore the importance of the reclamation of polluted sites to access more crop cultivation land (Hossain et al., 2020).

Synthetic biology is the application of engineering, science, and technology to edit the genetic material of living organisms in order to enable them to perform new functions (Cameron et al., 2014). Such engineered organisms can provide robust solutions to our current environmental challenges. Using synthetic biology tools, microorganisms have been engineered to sense, quantify, and report the presence of specific environmental pollutants (Brutesco et al., 2017). These biosensors, reviewed in section two of this paper, provide simple and cost-effective techniques for monitoring water and soil quality. They are becoming a viable alternative to the currently used detection approaches, which are often expensive, constrained to sophisticated laboratories with expensive instrumentation, and require advanced technical expertise (Oliferova et al., 2005; Potter and Pawliszyn, 1994). Using the simpler sensors based on synthetic biology, communities, and

\* Corresponding author at: Department of Life Sciences, Chalmers University of Technology, Göteborg, Sweden.

\*\* Corresponding author.

E-mail addresses: [r.ledesma-amaro@imperial.ac.uk](mailto:r.ledesma-amaro@imperial.ac.uk) (R. Ledesma-Amaro), [ivan.mijakovic@chalmers.se](mailto:ivan.mijakovic@chalmers.se) (I. Mijakovic).

<https://doi.org/10.1016/j.biotechadv.2023.108239>

Received 15 April 2023; Received in revised form 17 August 2023; Accepted 20 August 2023

Available online 22 August 2023

0734-9750/© 2023 The Authors. Published by Elsevier Inc. This is an open access article under the CC BY license (<http://creativecommons.org/licenses/by/4.0/>).

individuals could economically and rapidly monitor the water and soil quality to meet their local needs. In this review, we describe the most commonly used synthetic biosensors. Their functions, advantages, and challenges are discussed (Fig. 1).

In section three of the review, we focus on bioremediation. An overview of synthetically engineered microbes that can degrade persistent chemicals is presented (Jaiswal and Shukla, 2020). We describe model and non-model microorganisms genetically engineered for bioremediation applications. We highlight the effective use of the CRISPR technology in genetically engineered archaea and bacteria for bioremediation. Various new techniques in advanced bioremediation are discussed, including biofilm engineering, artificial microbial communities, gene drive, insect engineering, as well as enzyme and protein engineering.

We also present an overview of the latest trends in bioremediation adapted for major classes of soil pollutants, including heavy metals, pesticides, hydrocarbons, and plastics. Environmental safety of microorganisms genetically engineered for bioremediation is critical in this field. Thus, the key risks related to the application of genetically engineered microbes are discussed, namely, genome-level interactions with the native microbial communities, selection pressure on non-target microflora, and unintentional spreading of antibiotic resistance genes (Jaiswal and Shukla, 2020). In the second part of the bioremediation section, multiple phytoremediation techniques are discussed, including phytoextraction, phytostabilization, rhizofiltration, and phytovolatilization. An exhaustive list of plant genes known to be involved in the phytoremediation of different heavy metals and herbicides is presented.

Section four of the review describes computational approaches that facilitate synthetic biology applications in environmental protection. Computational models represent valuable tools for exploring possible metabolic and other interactions within microbial communities. Such modeling approaches can facilitate the design of relatively complex strategies for engineering or/and bio-augmentation of microbial consortia with enhanced capacity to bioremediate specific pollutants.

In summary, in this review, we present synthetic biology approaches applied in bioremediation, including prediction of toxicity and degradation pathways, genome editing, metabolic engineering, synthetic biosensor systems, construction of synthetic genetic circuits in engineered microbial communities, and implementation of computational models allowing for community-level interventions.

## 2. Synthetic biology tools in constructing biosensors

Microbes have evolved abilities to sequester, pump out or metabolically inactivate large amounts of toxins. These innate mechanisms are the starting points for synthetic biology applications, aiming to engineer superior new microorganisms for bioremediation. As the technology for genome editing advanced (Engler et al., 2008; Gibson et al., 2009), so did our ability to engineer cells to perform novel functions. This ability, combined with the elucidation of novel toxin mediation systems in nature (Mutschler et al., 2011), allowed for the introduction of these systems into model organisms, which resulted in advanced biosensing systems (Shaw et al., 2019). Herein, we highlight several recent examples and discuss current methods to improve biosensing technologies.

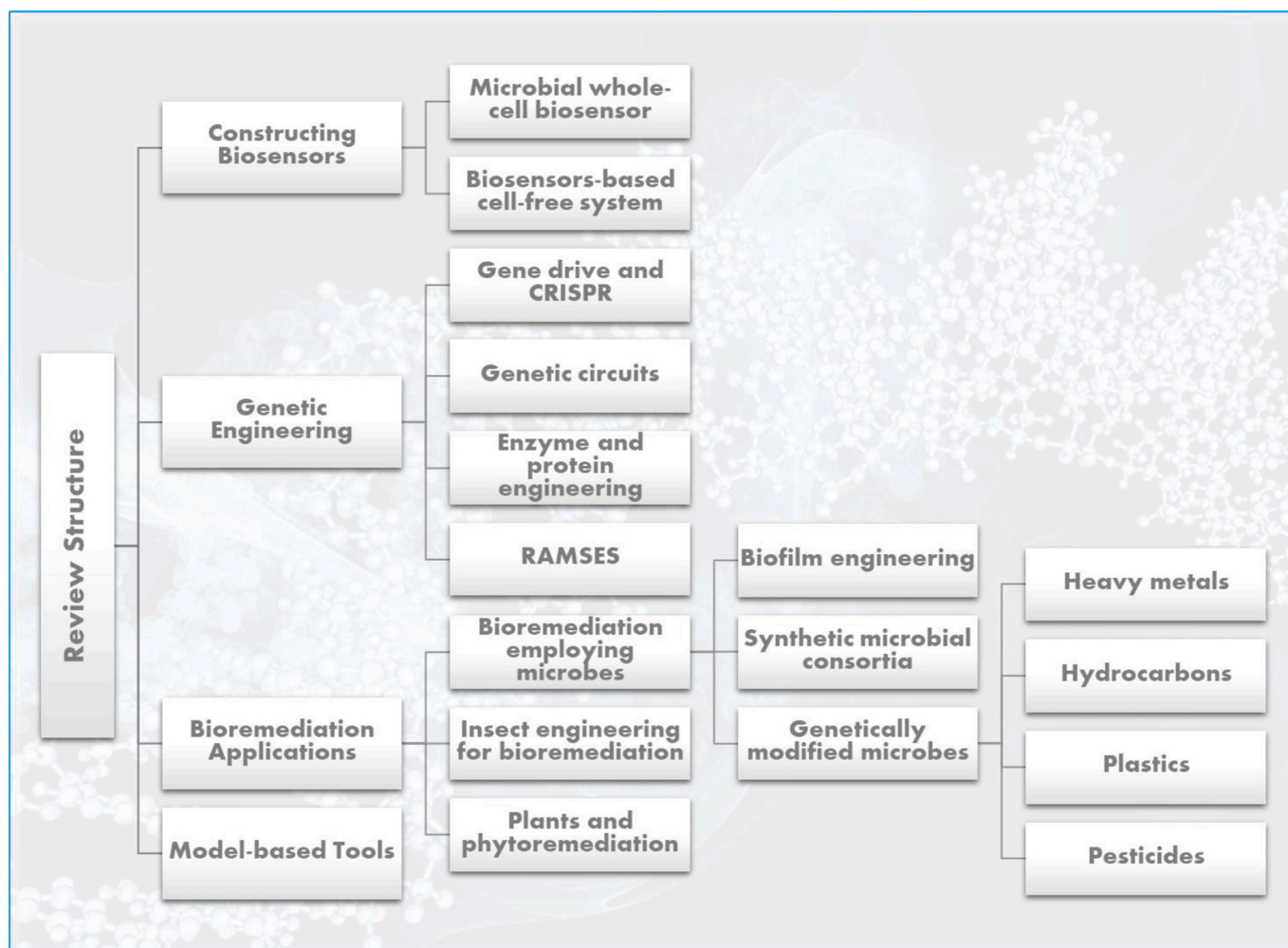

Fig. 1. An overview of the review structure.

## 2.1. Microbial whole-cell biosensors

Microbial whole-cell biosensors (MWCBs) are analytical, biological devices with a genetic element that acts as a sensor, capable of recognizing an analyte or a toxin, together with a reporter protein, capable of generating a quantifiable output signal (Daunert et al., 2000; Jiang et al., 2021; Wahid et al., 2023). This signal can be measured using inexpensive spectrophotometers or even visualized by the naked eye, adding to the benefits of MWCBs compared to the conventional use of spectroscopy and chromatography (Oliferova et al., 2005; Potter and Pawliszyn, 1994). These microorganisms typically are modified in their genome or with episomal plasmids to harbor the genes needed to assimilate the cellular response to the target analyte with the reporter. According to the reporter protein's expression type, the MWCBs can be classified as constitutive or inducible systems (Moraskie et al., 2021). Constitutive biosensors have reporters with a high basal signal due to the constitutive expression of the gene that encodes them. This signal can decrease proportionally to the toxicity of a sample tested due to changes in cell metabolism or cell viability (Fig. 2 (a)) (Mirasoli et al., 2002). Despite this type of MWCBs not being too specific, it is beneficial to determine the toxicity of complex samples in water, soil, or other environments (Bulich and Isenberg, 1981; Ramanathan et al., 1997). In the inducible MWCBs, the cells are engineered to identify different compounds by changing the expression of reporter proteins under an inducible promoter (Fig. 2 (b)). In this case, the promoter activation depends on regulatory proteins that recognize the analyte or some intermediates. Selection of the ideal promoter and the regulatory proteins involved are critical and require knowledge about the host and the genes responding to the specific analyte (Gutiérrez et al., 2015). However, compared to the constitutive MWCBs, the advantages of inducible systems include high sensitivity, specificity, modularity, and high throughput *in situ* detection (Moraskie et al., 2021).

Several MWCBs, mainly bacterial, have been developed and successfully applied to monitor environmental pollution (Table 1) (Chang

et al., 2017). One of the first biosensors of this type was a sensor for naphthalene, a polycyclic aromatic hydrocarbon (PAH) present in water and soil environments. By inserting *lux* genes, which control the synthesis of the bioluminescent protein luciferase, into the *nahG* site encoding a salicylate hydroxylase of the strain *Pseudomonas fluorescens*, it was possible to detect aromatic hydrocarbon contamination of soils (King et al., 1990). This strategy has been rebuilt by expressing the same naphthalene-degrading operon, *nahAD*, and the operons *salAR* and *luxCDABE* in the *Acinetobacter* ADPWH<sub>lux</sub> host strain. The *nahAD* operon, cloned in an episomal plasmid, enables the cell to respond to naphthalene by producing salicylate. This signaling metabolite can be detected by the induction of the operons *salAR* and *luxCDABE* (Fig. 3). This new reporter system showed higher selectivity, as it was not activated by other polycyclic aromatic hydrocarbons (PAHs). It also exhibited high sensitivity, responding to concentrations as low as 0.01 mM naphthalene (Sun et al., 2017). Since salicylate is a central molecule in the metabolism of most PAHs, this new method provided the possibility to construct several biosensors responsive to different PAHs by replacing the episomal plasmid with the respective PAH operon. With the use of popular DNA assembly methods for plasmid construction, such as Golden Gate or Gibson assembly, it is possible to efficiently construct new synthetic gene circuits, allowing a rapid detection and monitoring of contaminated environments.

Other toxic compounds, abundant in water and soil, are heavy metals, including but not limited to nickel (Ni), cadmium (Cd), arsenic (As), lead (Pb), and copper (Cu) (Table 1). MWCBs can be used for metal detection, although specificity is still challenging. For example, differentiating between metals with chemical similarities, such as Co and Ni, has been cumbersome. However, a few regulatory proteins that responded only to Ni have been recently used to develop a bioluminescent *E. coli* sensor for detecting high levels of Ni in drinking water (Cayron et al., 2017). For this, site-directed mutagenesis was carried out on the metallo-regulator RcnR Ni/Co (repressor) to increase the specificity for Ni. One of these mutants, C35A RcnR, completely abolished the

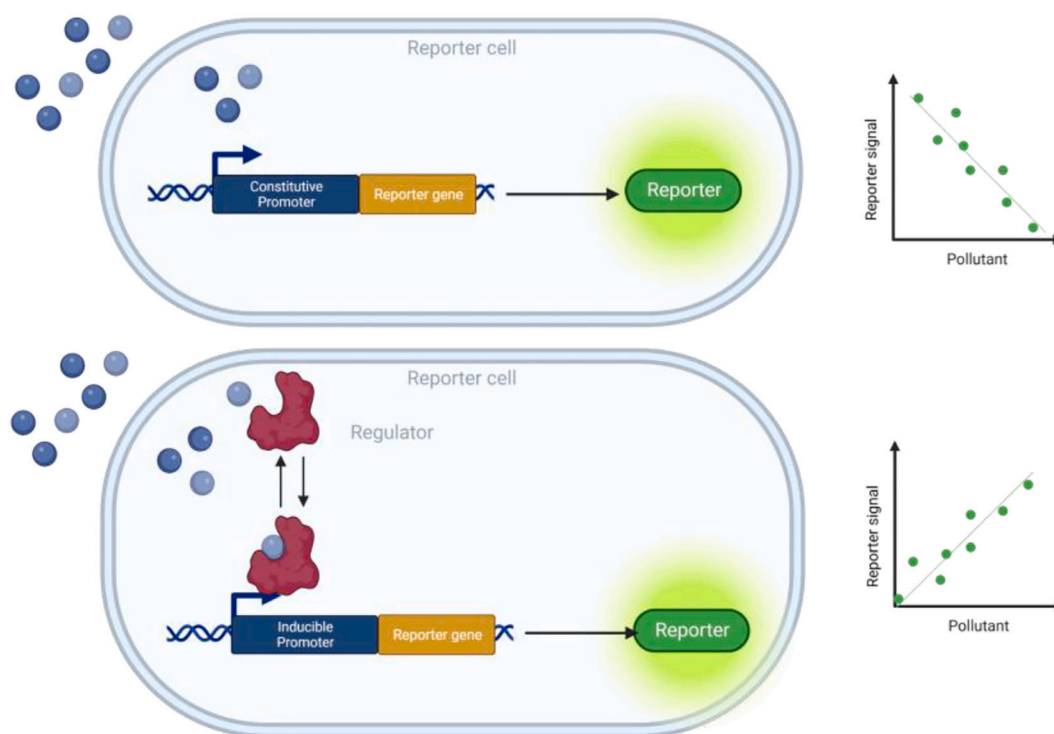

**Fig. 2.** Microbial whole-cell biosensor classification depending on the expression of the reporter. (a) Constitutive MWCBs show high signals of the reporter due to their constitutive expression. The signal decreases proportionally to the toxicity or concentration of the toxic analyzed. (b) In the inducible MWCBs, the reporter signal is absent or has a low basal level. The promoter activation depends on regulatory proteins that bind to the analyte or intermediates, creating a complex that can initiate the expression of the reporter.

**Table 1**  
Different applications of microbial whole-cell biosensors on different pollutants.

Pollutant	Microorganism	Gene/construct	Effect	Ref.
Naphthalene	<i>Acinetobacter sp.</i> ADP1	Plasmid with operon nahAD expressed in the <i>Acinetobacter</i> ADPWH <sub>lux</sub> host	Detection of naphthalene as low as 0.01 $\mu\text{M}$	(Sun et al., 2017)
Ni	<i>Escherichia coli</i>	Plasmid with lux genes fused to rcnA promoter. Mutagenesis of the regulatory protein RcnR. Deletion of efflux pump and overexpression of Ni uptake proteins	Detection of Ni as low as 80 nM	(Cayron et al., 2017)
Cd <sup>2+</sup>	<i>Escherichia coli</i>	Plasmid with <i>pzntA</i> fused to GFP	Detection of Cd <sup>2+</sup> as low as 2 $\mu\text{g/L}$	(Elcin and Öktem, 2020)
Cd <sup>2+</sup>	<i>Pseudomonas putida</i>	Plasmids with a gene circuit with positive and negative feedback. The positive loop enhances the production of mCherry reporter	Detection of Cd <sup>2+</sup> as low as 0.1 nM	(Hu et al., 2023)
As(III)	<i>Escherichia coli</i>	Plasmid with the mCherry under the <i>luxR</i> positive loop <i>luxR</i> and <i>arsR</i> under the <i>arsR</i> promoter	Detection of As(III) as low as 0.1 $\mu\text{M}$	(Jia et al., 2019)
Pb <sup>2+</sup>	<i>Escherichia coli</i>	Plasmid with GFP under the <i>luxR</i> positive loop. <i>luxR</i> and <i>pbrR</i> under the <i>pbrR</i> promoter	Detection of Pb as low as 0.001 $\mu\text{M}$	(Jia et al., 2018)
Hg(II)	<i>Escherichia coli</i>	Plasmid with the violacein operon under the mercury resistance promoter ( <i>mer</i> ) and regulator ( <i>MerR</i> )	Detection of Hg(II) as low as 0.39 $\mu\text{M}$	(Guo et al., 2021)
Cu	<i>Saccharomyces cerevisiae</i>	Plasmid with <i>pCUP1</i> fused to <i>LacZ</i> gene	Detection of Cu <sup>2+</sup> in a concentration range between 0.5 and 2 mM CuSO <sub>4</sub> due to lactose consumption by cell	(Lehmann et al., 2000)
Cu	<i>Saccharomyces cerevisiae</i>	Plasmid with <i>pCUP1</i> fused to luciferase. A second luciferase was used as cell viability control	Dual color response to Cu <sup>2+</sup> up to 0.5 $\mu\text{M}$	(Roda et al., 2011)
Cu	<i>Saccharomyces cerevisiae</i>	Plasmid pYEX-GFPuv harboring the <i>pCup1</i> fused to GFP	Detection of Cu <sup>2+</sup> as low as 0.5 $\mu\text{M}$	(Shetty et al., 2004)
Cu	<i>Saccharomyces cerevisiae</i>	Deletion of the <i>ADE2</i> gene Replacement of the native <i>ADE5,7</i> gene promoter with <i>pCUP1</i>	Red pigmentation of cells in the presence of Cu <sup>2+</sup> proportional to the range of 1–100 $\mu\text{M}$	(Vopálenská et al., 2015)
Cu	<i>Saccharomyces cerevisiae</i>	Dual reporter fluorescent system for Cu detection and cell viability, combined with promoter and transactivator engineering	Detection in the range of 10 nM to 10 mM	(Žunar et al., 2022)

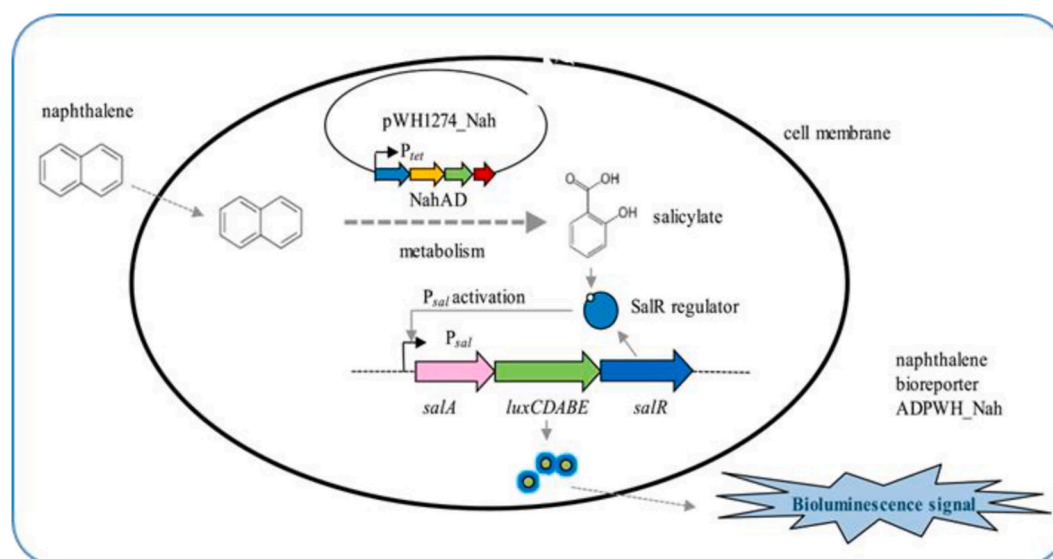

**Fig. 3.** An overview of Naphthalene metabolism with *salAR* operon induction associated with salicylate. The figure was adapted with permission from (Sun et al., 2017).

response to Co, resulting in lower sensitivity for Ni. To overcome this problem, the deletion of *rcnA*, a Ni efflux pump, and the expression of transporters to mediate Ni uptake, such as pNik, increased the sensitivity and specificity of Ni detection. Other heavy metal whole-cell biosensors have also used the same principles to detect Cd (Elcin and Öktem, 2020; Hu et al., 2023). As (Jia et al., 2019), and Pb (Jia et al., 2018). Recently, a new type of biosensor was developed in this same host, using a mercury resistance promoter (*P<sub>mer</sub>*) and mercury resistance regulator (*MerR*) to sense mercury in the environment and report it *via* activation of violacein pigment as a reporter (Fig. 4). Compared to the typical sensors based on fluorescent protein (eGFP), the response time of violacein was faster, 5 h instead of 8 h (Guo et al., 2021).

In addition to bacterial sensors, a few *Saccharomyces cerevisiae* biosensors have also been constructed for the detection of organic

molecules (Moscovici et al., 2020) and heavy metals, especially copper ions, due to the presence of their inducible CUP1 promoter, widely used in expression systems (Maya et al., 2008). The activation of the CUP1 promoter fused to the reporter genes allowed the detection of Cu<sup>2+</sup> ions with a detection threshold as low as 0.5  $\mu\text{M}$  in the case of using the GFP (Shetty et al., 2004) and 0.5 mM in the case of LacZ (Lehmann et al., 2000). But since industrial wastewater or seawater can be complex and polluted matrices, cell viability may be affected, giving less robustness and sensitivity to these single reporters. The next generation of MWBCs were two reporters are expressed in a single cell, one responding specifically to metal concentrations and the other expressed constitutively as an internal control of cell viability, can be constructed and used to correct the signal lost due to cell toxicity (Roda et al., 2011). A dual system with two luciferases (Roda et al., 2011) and, more recently, two



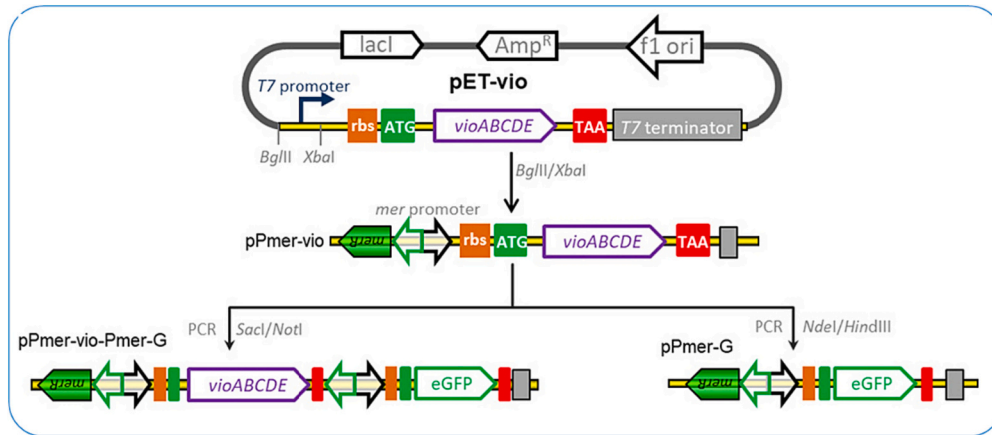

Fig. 4. Mercury resistance regulator operons for sensing Hg (II). Fluorescent reporter and violacein biosynthesis modules were assembled under the promoter. The figure was adopted with permission from (Guo et al., 2021).

fluorescent proteins responds to Cu ions with higher sensitivity and specificity, allowing the detection in the range of  $10^{-8}$  to  $10^{-3}$  M for the latter (Žunar et al., 2022). Finally, a simpler and more stable yeast sensor was created based on ADE2 deletion, which generates red colonies due to the accumulation of purine intermediates. Using this phenomenon, *S. cerevisiae* strains expressing the second gene of the purine

pathway, ADE5,7, under a CUP1 promoter, were capable of detecting Cu ions proportional to concentrations in the range of 1–100  $\mu$ M (Vopálenká et al., 2015). By creating a simple color change test readable by the naked eye and without specialized equipment, this biosensor was successfully tested in natural water samples contaminated with Cu, demonstrating its potential.

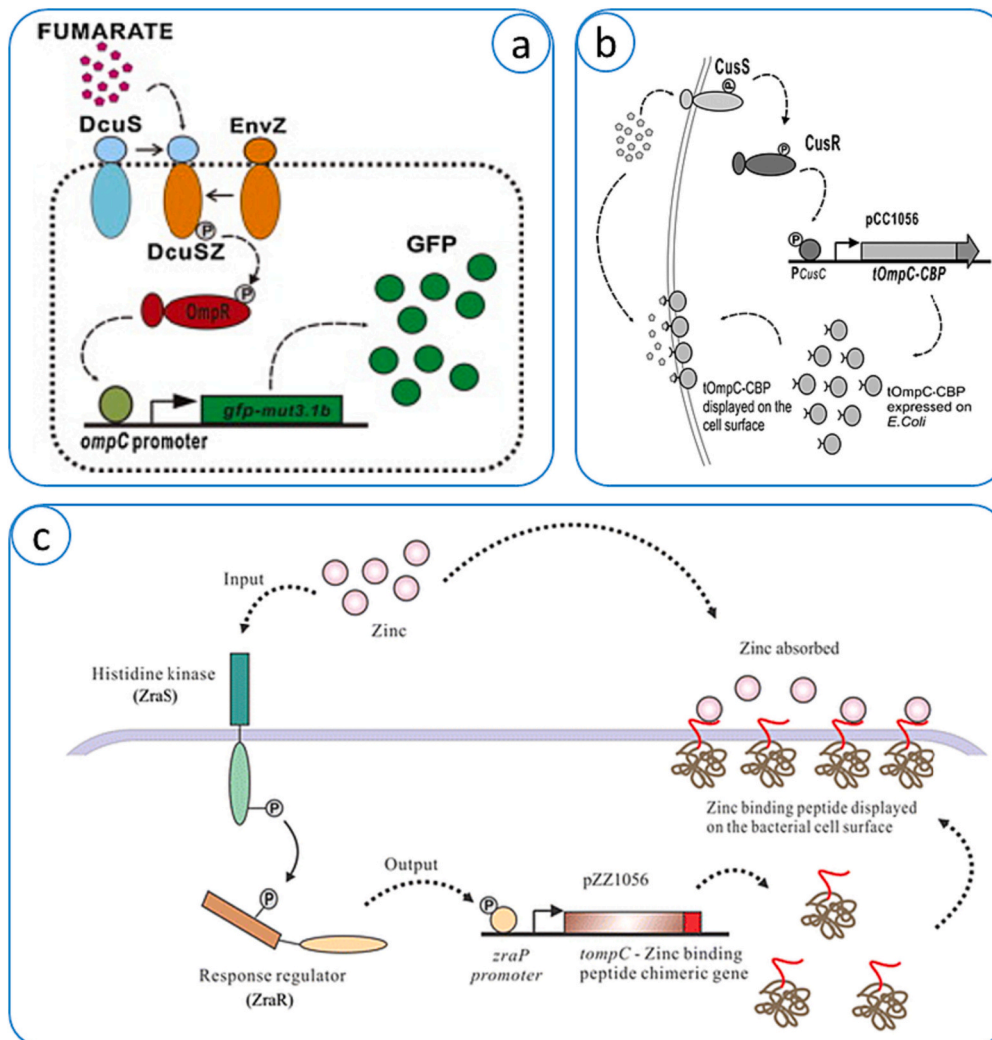

Fig. 5. (a) In *E. coli*, the histidine kinase (HK) *DcuS* responsible for sensing fumarate and the catalytic domain of *EnvZ* formed a chimeric protein under fusion. Under a phosphorylation process of *ompR*, *DcuSZ* activates *ompC* operon to express GFP. The figure was adopted with permission from (Ganesh et al., 2013); (b) *CusS* senses Cu ion, followed by HK domain and *OmpR*, which activates *CusSR*. This results in Cu ion-binding peptide on the microbe surface. The figure adopted with permission from (Ravikumar et al., 2011a); and (c) *ZraS* senses Zn ion, followed by HK domain and *OmpR*, which activates *ZarSR*. This results in Zn ion-binding peptide on the microbe surface. The figure was adopted with permission from (Ravikumar et al., 2011b).

Despite the recent development of biosensors, there are very few examples of their use in commercial products. This is partly related to the often limited specificity and selectivity and the feasibility of applying them on-site (portability, biocontainers, analysis time, and costs) (Brutesco et al., 2017). Nevertheless, these limitations can be overcome by improving our knowledge of cell metabolism and physiology, as well as improvements *via* genetic engineering. The following sections will discuss recent advances in two-component regulatory systems (TCRS) and cell-free extract (CFE) biosensors.

Two-component regulatory systems (TCRSs) are mostly found in prokaryotes and a few eukaryotic organisms, where the cells sense environmental changes and display a regulated response. The general mechanism of a TCRS consists of a histidine kinase receptor (HK) and a response regulator (RR) (Zschiedrich et al., 2016). The HK protein recognizes a signal and activates an ATP-dependent autophosphorylation of a conserved histidine residue. Then, this phosphoryl group is transferred to an aspartate residue in the RR, allowing its binding to specific promoter's sequences, either activating or repressing target genes. Since several TCRS can sense a broad range of signals, including organic compounds and metals, their potential application as biosensors has been extensively examined. For example, the EnvZ/OmpR system, one of the most studied TCRS in *E. coli*, responds to changes in osmolarity by regulating the expressions of membrane porins, *OmpF*, and *OmpC* (Egger et al., 1997). Chimeras between different HKs and the osmosensor *EnvZ* have been constructed, increasing the response by the cell to the molecules sensed. A fusion between the HK *DcuS* capable of recognizing fumarate, with the catalytic domain of *EnvZ*, along with an *ompC*-GFP reporter, were enough to create an anaerobic fumarate biosensor (Fig. 5 (a)) (Ganesh et al., 2013).

In contrast with the natural *DcuS/R* TCRS, this new system provided an enhanced output signal. Similarly, cells can be engineered to display proteins on their surface to absorb metals. A Zinc and Copper adsorption system was developed by fusing the respective RR to the *OmpC*, displaying binding peptides capable of acting even at a low concentration

(0.001 mM for Zinc) (Ravikumar et al., 2011a, 2011b). For more information, refer to Fig. 5(b) and 5(c).

The combination of sensing and absorbing systems can enable the monitoring and removal of toxic metals or other target compounds, increasing the sensor's functionality. Future works are expected to shed light on the mechanisms of action of sensors, which will facilitate their engineering to improve their sensing range and sensitivities.

## 2.2. Biosensors-based cell-free systems

CFE biosensors (also called cell-free transcription/translation -TXTL-systems) can sense, respond, and mediate contaminants in the environment. They are functionally similar to MWCBS; however, they are completely independent of cellular processes and work based on the isolation of genetic circuitry required to sense and respond. The use of CFE biosensors removes the risk of plasmid loss and genetic instability, as well as the requirement for biocontainment when released in areas of deployment. These biosensors are also suitable for high-throughput assays (Carlson et al., 2012). An excellent example of this technology is a study that uses a CFE biosensor to detect atrazine, an agricultural herbicide detected in surfaces and well waters samples that has become a threat to the environment (Silverman et al., 2020).

CFE and other types of biosensors have limitations in terms of the range of chemicals they can detect, which can be overcome by pairing metabolic pathways with transcription factor-based networks. Bioinformatic tools can be used to identify synthetic pathways to convert undetectable molecules into detectable ligands, engineering modular CFE biosensors to be designed for a wide range of applications. This strategy detected benzoic acid, hippuric acid, and cocaine using a fast and optimized CFE (see Fig. 6) (Voyvodic et al., 2019). This approach can also be applied to metal detection. Previously, biosensors for the detection of mercury had been developed based on the Hg-responsive MerR transcription activator found in Gram-negative bacteria (Brown et al., 2003). Using this circuit, a paper-based CFE sensor has recently

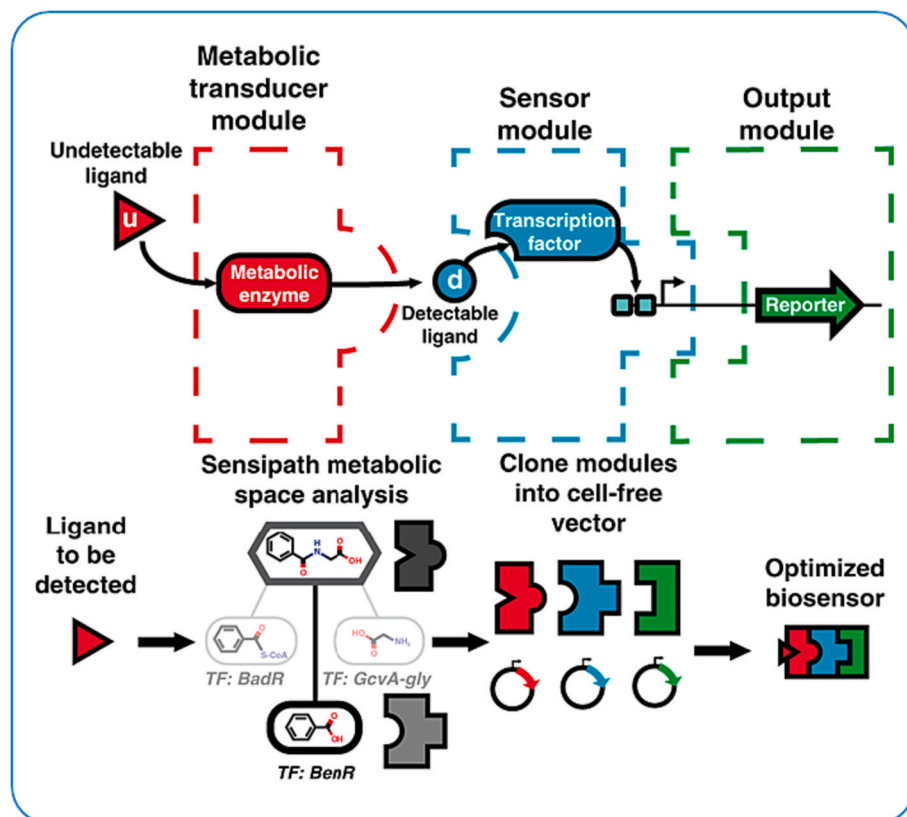

**Fig. 6.** A design for engineering modular CFE biosensors. It outlines a cascade system that incorporates several modules defined as a metabolic transducer module, a sensor module, and an output module. In this example, *BenR*, a transcription factor constitutively expressed from the sensor plasmid, binds to  $P_{Ben}$  promoter in the presence of benzoate, thus initiating the transcription of *sfGFP* in the output plasmid. To expand its chemical detection, a new transducer module was designed to convert hippuric acid and cocaine into benzoic acid, using the enzymes *HipO* and *CocE*, respectively, demonstrating the system's scalability. The figure was adapted with permission from (Voyvodic et al., 2019).

been engineered where MerR activates the expression of sfGFP via the *mer* operator in the presence of Hg (II) ions. The system detected 6  $\mu\text{g/L}$  of Hb (II) ions in contaminated water (Gräwe et al., 2019).

Further development of CFE biosensors has led to the utilization of RNA-based components in regulation (Thavarajah et al., 2020) and output (Jung et al., 2020). A novel riboswitch-based CFE biosensor for environmental fluoride was developed for point-of-use applications (Fig. 7 (a)) (Thavarajah et al., 2020). The premise of this technology was based on a fluoride-sensitive riboswitch from *Bacillus cereus*, *CrcB*, that regulates the expression of *CrcB*, a fluoride efflux pump. This regulatory RNA was utilized in the CFE sensor to control the expression of sfGFP. The sensitivity of this RNA-based CFE system for the detection of fluoride was sufficient to detect the maximum containment level of 2 ppm, as defined by the Environmental Protection Agency (Thavarajah et al., 2020). In addition, to sense water contamination, a fluorescent RNA, instead of protein, was used as an output (Fig. 7 (b)). RNA output sensors activated by ligand induction (ROSALIND) use a combination of highly processive RNA polymerase (T7 phage RNAP), allosteric protein transcription factors (aTF), and DNA transcription templates to regulate the synthesis of the final output of these constructs: a fluorescence inducing RNA aptamer which generates the last signal. The presence of a target contaminant, in this case, organic molecules and metals, induced the mobilization of the aTF, unblocking the RNAP elongation and allowing the production of the aptamer called the three-way junction dimeric Broccoli (3WJdB). Commercial RNA binding dyes, such as DFHBI-1 T, activated the fluorescence of the RNA, used as a detection method. The authors further moved on to increase the sensitivity of ROSALIND tuned by using RNA-feedback systems, which improved the detection limits of toxic compounds (Jung et al., 2020).

The use of RNA systems enables the development of RNA feedback systems, which optimize detection limits for new control variables. These RNA systems introduce new elements of control, offering a higher range of orthogonality, increased sensitivity, and the ability to invert transcription factor responses. The concentrations of transcription factors within the CFE system can be tuned to enhance the functionality of these RNA systems. Additionally, the modularity of RNA systems can be adapted to sense various compounds such as tetracyclines (Xiao et al., 2008), small molecules (Breaker et al., 2017; Husser et al., 2023; Nelson et al., 2017), and metals (Furukawa et al., 2015).

Many of the systems developed for biosensing have modular and engineerable genetic components. The engineered approach provides a

“plug-and-play” utility to these biosensing systems, allowing for high-throughput, high engineerability and portability, and easy optimization. Even though the primary limitation associated with CFEs is the high cost of their production and deployment at an industrial scale, the current advances in lysate systems are making them a more viable option (Smith et al., 2014). The large and increasing range of pollutants that CFE sensors can reliably detect indicates that they are likely to become mainstream tools in monitoring environmental pollution.

### 3. Synthetic biology tools in genetic engineering

Establishing a genetically engineered system requires a proper chassis, gene editing, and tools to control and monitor genetic reprogramming. The latest trend in bioremediation with the help of synthetic biology has been the application of non-model organisms as hosts, CRISPR as editing, and genetic circuits as pre- and post-engineering tools (Liang et al., 2020; Thorwall et al., 2020; Volke et al., 2023).

Based on the accessibility of metabolic pathways and ease of laboratory experiments, microorganisms are divided into model and non-model types, with the first category being prioritized for most synthetic biology work. However, the application of non-model organisms in bioremediation research has become focused lately due to their unique capacity for selective contaminant degradation based on exclusive metabolic pathways, carbon source utilization, and natural resistance to extreme conditions. Despite the considerable limitation of genetic tuning in non-model organisms arising from high genomic GC content, the scientific community managed to resolve these issues in some species (e.g., *Rhodococcus spp.*) by discovering and developing new genetic parts (such as reporter genes, shuttle vectors, ribosome binding sites, and promoters), delivering more efficient gene expression and manipulation (Liang and Yu, 2021). The following sections discuss specific classes of synthetic biology tools used for bioremediation, including gene drive and CRISPR-enabled tools, genetic circuits, enzyme and protein engineering, and some new bioremediation technologies.

#### 3.1. Gene drive and CRISPR-enabled tools

A newly adopted strategy in bioremediation that can be applied to large-scale pollution is gene-drive, which leads to the spreading of a particular favored gene in a whole microbial consortium or a single species population (Borchert et al., 2021). Previously, horizontal gene

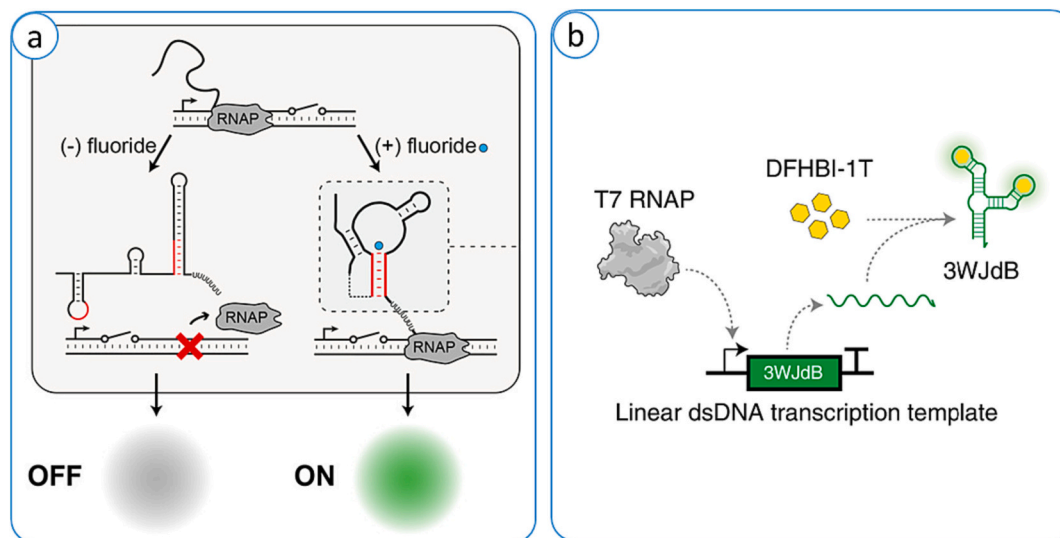

**Fig. 7.** Examples of RNA-based components in (a) regulation and (b) output. (a) Schematic of a CFE fluoride biosensor for controlling sfGFP. RNA riboswitch-based biosensor systems can be used in a real-world environment. The figure was adapted with permission from (Thavarajah et al., 2020). (b) T7 phage RNAP and aptamer and three-way junction dimeric Broccoli (3WJdB) can activate DFHBI-1 T fluorescence. The figure was adapted with permission from (Jung et al., 2020).



transfer has been exploited to clean up a contaminated site with petroleum derivatives (French et al., 2020). This was done by inoculating an *E. coli* strain carrying effective degradative genes (*alma*, *xyle*, *p450cam*) into the polluted sediments. Thereafter, native microbial consortia acquired the relevant genes and removed petroleum hydrocarbons at the site. Transferring degradative genes to local microbial communities is advantageous because there is no risk of possible ecosystem disturbance by outsider species (French et al., 2020).

Among various genome editing techniques, including TALEN, ZFN, and CRISPR, which act as artificial molecular scissors to cut the DNA at specific sites, CRISPR has proven most effective and straightforward, especially for archaeal and bacterial systems. The most significant benefit is its ability to be applied at multiple sites and high potency in implementing common engineering goals, including insertion, deletion, substitution, and site mutation (Dangi et al., 2019; Wang et al., 2021). CRISPR toolkit is majorly applied to model microorganisms like *Pseudomonas* and *E. coli*. Its application has also expanded to non-model organisms such as *Rhodococcus ruber TH*, *Comamonas testosteroni*, and *Achromobacter sp. HZ01* (Jaiswal and Shukla, 2020). Recently, various CRISPR-based genetic modification systems have been developed for extremophiles, including thermophiles, acidophiles, and halophiles which can play a key role in the advancement of bioremediation studies using these types of microbes (Mougiakos et al., 2017; Qin et al., 2018; Thorwall et al., 2020; Yamada et al., 2022; Ye et al., 2023). CRISPR has also been applied to biosurfactant-producing organisms to improve bioelectrokinetic remediation systems for the degradation of aromatic hydrocarbons and pesticides (Bokade et al., 2023; Phulpoto et al., 2022).

CRISPR interference (CRISPRi) is an engineering tool to down-regulate the expression of undesirable genes and regulate metabolic flux toward the overproduction of favorable products (Yi and Ng, 2021) (Volke et al., 2023). Conversely, a CRISPR activation (CRISPRa) tool enables the organism to upregulate a desired gene (Volke et al., 2023). For example, (DeLorenzo et al., 2018) reported the application of a CRISPRi tool to create the first system of targeted gene repression in a non-model lignocellulolytic bacterium (*Rhodococcus opacus* PD630).

CRISPR application in bioremediation for enhanced bioremoval, stress tolerance, and optimized biodegradation pathways, in general, is scarce and deserves more attention in the future. One of the early applications of CRISPR technology in bioremediation is targeted knockout and knock-in, which aided the researchers in verifying a particular gene's role and function. A notable example is a recent study by (Gallo et al., 2021), who confirmed the arsenite resistance gene (TtarsM) contribution to the detoxification system in a thermophilic bacterium (*Thermus thermophilus* HB27) using a targeted knockout by Thermo-Cas9 tool. These types of targeted knockout are also an excellent tool for optimization of CRISPR editing efficiency in non-model organisms which in turn offers the opportunity for further pathway tuning by CRISPRi and CRISPRa and multiplex genome editing (Gallo et al., 2021; Thorwall et al., 2020).

Studies about bioconversion of waste to value-added products were more profoundly pursued using the CRISPR technique. In lignocellulosic waste valorization, CRISPR-based protein engineering of lignolytic enzymes has been introduced as the most promising technology for enzyme overproduction (Asemoloye et al., 2021). Another waste bioconversion area that benefited from CRISPR is the fermentation of greenhouse gases such as CO, CO<sub>2</sub>, and CH<sub>4</sub> (also known as C-1 gases) into various value-added products. Many acetogenic bacteria application on large-scale is burdened by their low growth rate and yield on C-1 gases. CRISPR-mediated gene editing recently showed promise to overcome this limitation. *Clostridium ljungdahlii* and *Eubacterium limosum* are two acetogenic bacteria that primarily underwent CRISPR-mediated gene editing (Jin et al., 2020). For example, the utilization of two promoters (P<sub>thl</sub>, P<sub>araE</sub>) for Cas9 and sgRNA expression and the deletion of four genes (*pta*, *adhE1*, *ctf*, and *pyrE*) from *Clostridium ljungdahlii* had a beneficial effect on the growth rate, as well as on acetic and ethanol formation from the fermentation of C-1 gases (Huang et al., 2016).

CRISPRi toolbox was also applied to *Clostridium ljungdahlii* for enhanced greenhouse gas fermentation to butyric acid and reduction of carbon flux into the side pathway of ethanol production (Zhao et al., 2019).

One of the main challenges with CRISPR-based gene modification is off-target editions which occur through DNA cleavage in unwanted locations due to the sequence similarity to the target location (Braddick and Ramarohetra, 2020). Attention to this context is critically important, especially in developing CRISPR-based gene drives for bioremediation purposes to prevent undesirable changes in the natural ecosystem. To this end, numerous strategies have been developed to ensure the safety of CRISPR-based genetic engineering and gene drive (see Table 2).

### 3.2. Genetic circuits

Analogous to an electric circuit, genetic circuits can be designed and built from constituting molecular parts: reporter genes, metabolic genes, promoters, replicons, and selectable markers. These can be used to alter cell behavior, enhance metabolic output, or monitor post-engineering metabolic activity. The availability of suitable genetic elements is of paramount importance for the construction of such genetic circuits. Lack of reporter systems and inducible promoters, for example, have limited the use of genetic circuits engineering of acetogens to improve the conversion of air pollutants to value-added products (Jin et al., 2020). Therefore, characterizing new and efficient genetic parts is essential for effective genetic reprogramming (Jin et al., 2020; Wang et al., 2021). For instance, the development of efficient inducible and constitutive promoters for *Cupriavidus metallidurans* CH34, a multipurpose chemolithoautotrophic organism with applications in aromatic compounds degradation, bioelectricity generation from wastewater and biomineralization of precious metals, helped to control protein production and optimize CRISPR editing efficiency (Turco et al., 2022).

Application of genetic circuits can also be combined with CRISPRi to build transcriptional logic gates, controlling cellular behavior, such as sugar consumption, by circuit output results (Nielsen and Voigt, 2014). Implementation of this strategy in acetogens has been used to link metabolic activity to environmental changes, e.g., a pH shift and a change in growth substrate concentration (Jin et al., 2020).

**Table 2**  
Biosafety approaches for engineered species.

Strategy 1	Optimization of CRISPR gene edition efficiency with better control over its components function, e.g., Cas9 enzyme, gRNA, and also better genetic elements, including promoters, inducible, etc. (Bhagtaney and Sundarajan, 2023; Braddick and Ramarohetra, 2020).
Strategy 2	Precautionary measures including meticulous selection of modification site to minimize cleavage of similarly sequenced off-targets and apply <i>in silico</i> predictions (using online bioinformatic services, e.g., Cas-OFFinder, TALE-NT, PROGNOSE) to provide a picture of possible off-target mutations (Bhagtaney and Sundarajan, 2023; Braddick and Ramarohetra, 2020).
Strategy 3	Post-engineering measures including gene drive control methods (Cas9-triggered chain ablation (CATCHA) (Wu et al., 2016), chemical-based inactivation switch (Chae et al., 2020), engineered kill switch systems (Rottinghaus et al., 2022), RNA-guided drives (reversal, immunizing) (Esvelt et al., 2014)

\*CATCHA is a CRISPR-based system to call for brake in gene drive propagation in insect populations by turning future cas9 allele into a brake using a gRNA expressed from a U6:2 promoter (Wu et al., 2016). A reversal RNA-guide drive can reverse and remove genomic changes made in the initial drive by overwriting the engineered sequence (Esvelt et al., 2014). Immunizing RNA-guide drive can inhibit and halt an unintended drive by altering the off-target sequence (Esvelt et al., 2014). Kill switch is a biocontainment strategy causing cell death in response to activating a genetic circuit or chemical inducer generating toxins expression, protein denaturation, and genome degradation (Rottinghaus et al., 2022). Engineered kill switch systems driven by CRISPR deliver more efficacy and stability against mutational inactivation (Rottinghaus et al., 2022).

### 3.3. Enzyme and protein engineering

Biotreatment of complex structure environmental pollutants, such as lignin in paper and pulp effluents, pesticides, aromatic hydrocarbons, and plastics, relies on the robust activity of microbial degradative enzymes. These enzymes are naturally produced in insufficient quantities unless their expression is manipulated genetically (Singh et al., 2021; Wang and Sun, 2021). Currently, different tools are being used in genetically engineered bioremediation systems for enzyme optimization, including rational, semi-rational design, and directed evolution (Asemoloye et al., 2021). A rational restructuring of a carboxylase enzyme through the replacement of functional groups in the active site increased the biodegradation of a highly toxic phenol derivative (4-hydroxy styrene) by 40% while enhancing stereoselectivity 39-fold (Payer et al., 2018). On the other hand, directed evolution, a non-structure-based method relying on random mutations, has developed new features such as extreme pH resistivity in ligninolytic enzymes in fungi with some applications in bioremediation biorefineries (Asemoloye et al., 2021). Directed engineering of protein expression in peroxisome has also been suggested as the best approach to establishing synthetic methylotrophy in yeasts. This is particularly important in biological carbon capture processes by methylotrophic microorganisms, especially synthetically methanol-consuming yeasts (synthetic methylotrophs) like *Yarrowia lipolytica* (Fabarius et al., 2021).

In addition to the methods mentioned, recombinant DNA technology and heterologous expression have also been utilized to bolster enzyme production and purification at a large scale when genes with pollutant degradation ability are expressed in a microbial host. Activity and range of substrates have been improved by site-directed mutagenesis (Carr et al., 2020). Metagenomic analysis of unculturable environmental samples has also aided researchers in finding novel genes encoding degradative enzymes with specific functionality (Carr et al., 2020).

### 3.4. Rapid advantageous mutation screening and selection

A new screening method has been developed to rapidly identify the beneficial mutants after employing adaptive laboratory evolution (ALE). This can facilitate subsequent reverse engineering and construction of hyper tolerant and pollutant-degrading strains. Traditionally, whole-genome sequencing is performed after stepwise adaptation of strains to toxic substances or suboptimal growth conditions to reveal genetic change (Wang et al., 2019). However, the emergence of multiple mutations during ALE makes locating the affected genes problematic and time-consuming. In the rapid advantageous mutation screening and selection (RAMSES) method, adding mutated DNA to the culture at the exponential stage results in DNA incorporation into the chromosome by allelic replacement. The transformed strain is then used under increasing selected stress. Thus, advantageous mutants appear with promoted growth (Jin et al., 2022). A group of scientists utilized this method to characterize beneficial mutations in a lignin degrader bacterium (*Acinetobacter baylyi* ADP1) after exposure to a high concentration of ferulate (a lignin derivative aromatic compound). They further engineered the bacteria with the beneficial mutations (in genes *hcaE*, *hcaK*) to improve tolerance to ferulate (Fig. 8) (Jin et al., 2022).

## 4. Recent achievements in bioremediation applications

### 4.1. New bioremediation technologies

The bioremediation research effort was initiated by studying essential *in-situ* technologies such as bioaugmentation, biosparging, bioventing, and *ex-situ* methods like composting, landfarming, biopiling and bio-reactors (Jaiswal and Shukla, 2020). These methods were mainly applied to unmanipulated living organisms to mitigate environmental pollution. Later, researchers started to evaluate the ability of new natural bio-based enzymes, different isolated microorganisms, growth

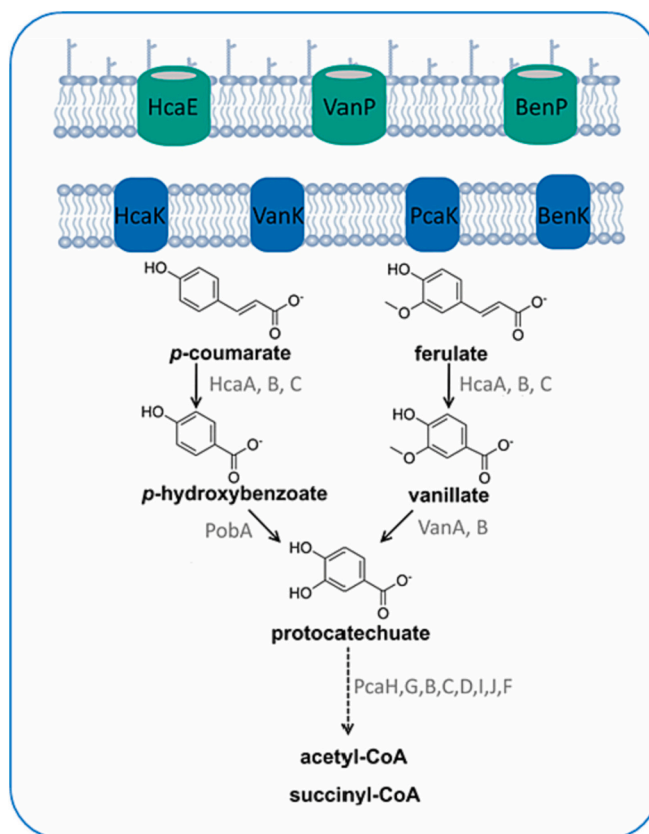

**Fig. 8.** Schematic of possible aromatic acid transport systems in *Acinetobacter baylyi* ADP1 (blue: transporters, green: porins). The dashed arrow refers to multiple steps. The figure was adapted with permission from (Jin et al., 2022). (For interpretation of the references to color in this figure legend, the reader is referred to the web version of this article.)

optimization, and applying simple gene-editing methods. Current synthetic biology efforts have successfully pushed the bioremediation barriers by adopting new techniques like biofilm engineering and synthetic microbial consortia.

#### 4.1.1. Biofilm engineering

Bioengineered biofilms are a recent line of research in bioremediation, developed to attenuate the effects of poisonous metals, hydrocarbons, and pesticides in nature and overcome natural biofilm limitations. A synthetic biofilm can be designed by incorporating signaling pathways, metabolic engineering of pathways, and extracellular polymeric substance (EPS) rearrangement (Li et al., 2022). The regeneration ability of biofilms allows them to be used sustainably, and the tunability of EPS composition enables specific functions for various bioremediation purposes. Bioleaching (heavy metal dissolution from the solid matrix), metal corrosion inhibition, and wastewater treatment with microbial fuel cells (MFCs) are some of the traditional bioremediation applications that biofilm engineering can further improve. For instance, a selective mercury detoxification system was established in which a mercury detector (MerR promoter) was constitutively expressed in *E. coli*. Then free mercury was dynamically sequestered through a synthesized nanofiber called curli (Tay et al., 2017). Moreover, a functional biofilm was fabricated with selective absorption capability for a rare earth element ( $Tb^{3+}$ ) by modifying curli fibers with lanthanide binding tags (Tay et al., 2018).

Such studies exemplified how bioengineered biofilms can be utilized for the selective recovery of heavy metals from wastewater and solid wastes. The future environmental research direction of synthetic biofilm involves its trial on a larger scale, optimization of responsive circuits,

and expanding engineering works from EPS proteins to other biofilm components like polysaccharides and nucleic acids (Li et al., 2022).

#### 4.1.2. Synthetic microbial consortia

Bioremediation can be significantly aided by finding desirable traits in artificially selected microbial communities (Chang et al., 2020). A synthetic microbial consortium involves the co-cultivation of particular strains with desirable traits. In this setup, each microorganism can partially participate in the degradation pathway. Hence, excessive engineering of a single strain and its related metabolic burden can be avoided. Also, understanding the cooperation effects among the microbial community members can open an avenue to discover novel enzymes and biodegradation pathways, leading to higher contaminant removal (Arias-Sánchez et al., 2019; Borchert et al., 2021; Xie et al., 2019).

Simultaneous remediation of multiple wastes and production of added-value products using hazardous wastes as raw materials is possible with engineered microbial communities. This could be accomplished by transforming biodegradation products into monomer units that can be used as feedstock for the biosynthesis of another product (Frandsen et al., 2018). For instance, ethylene glycol, a common chemical pollutant, was used as feedstock and turned into a bioplastic (polyhydroxyalkanoate (PHA)) by an engineered *Pseudomonas* strain. Researchers have also succeeded in exploiting hydrolyzation products (adipic acid, ethylene glycol, and 1,4-butanediol) of a recalcitrant plastic waste, polyurethane (PU), to feed a mixed culture of *Pseudomonas putida* derivatives and produce value-added products such as rhamnolipid (Catur Utomo et al., 2020). Another study reported the possibility of using a yeast-based consortium for simultaneous biofuel production and reactive azo dye removal from lignocellulosic materials. Synthetic yeast consortia in this study showed enhanced enzyme activity and higher reduction compared to the single culture of each member (Ali et al., 2020). Other examples include consolidated bioprocess of cellulose to produce organic acids from lignocellulosic waste by synthetic microbial consortia (Schlembach et al., 2020). The artificially selected microbial community has also been applied for the bioremediation of petroleum and acid mine drainage (Jaiswal and Shukla, 2020). This is undoubtedly one of the most significant lines of progress that synthetic biology has brought to bioremediation research owing to its opportunity to achieve zero-waste goals in many industrial processes by establishing a circular economy and industrial ecology model.

The stability of microbial communities, ecologically and evolutionarily, is one of the practical challenges in the field. Various measurement techniques for online and offline monitoring and controlling mixed culture population dynamics have recently been introduced (Schlembach et al., 2021). Applying a propagule strategy to evaluate the reproducibility and functionality preservation of two artificially constructed bacterial communities is one of the positive examples (Chang et al., 2020). The available toolkits for engineering a synthetic microbial community, including quorum sensing signaling molecules, inducers, and syntrophic interaction generation, have been recently reviewed (McCarty and Ledesma-Amaro, 2019).

Recent improvements in co-culturing methods, such as spatially linked microbial consortia (SLMC), have offered a chance to build synthetic microbial communities with incompatible physiological requirements (for instance, co-culture of acidophiles with alkaliphiles and aerobes with anaerobes), which is not possible using traditional techniques. SLMC involves engineering culture media environment rather than microbial strains and co-culturing different microorganisms inside interconnected modules (Said and Or, 2017). SLMC enables the exchange of metabolites between incompatible strains and provides more flexibility in selecting consortium members. However, controlling the population size in each module and flux exchange is challenging and has limited the concrete applications of this technology. (Ben Said et al., 2020).

#### 4.1.3. Bioremediation of soil and pesticides

Physical and chemical routes of soil detoxification, such as soil excavation and solvent-based washing, may negatively impact soil quality through unintended interruption of soil microbiome, nutrient cycle, and organic matter storage (Lin et al., 2022). Therefore, the advancement of bioremediation as a low-cost, labor-, energy- and chemical-saving method in pollution management is of the utmost importance. In this section, the latest trends in the bioremediation of major soil pollutants will be outlined (See Table 3).

- Heavy metals

There are various methods to mitigate and neutralize heavy metal threats to the environment. Sustainable, environmentally friendly options are bioleaching (extraction and dissolving), biosorption, bio-reduction (nanoparticle biosynthesis), biomineralization (precipitation and stabilization), phytoremediation (plants), and newly emerged methods such as binding peptides and siderophores (Pollmann et al., 2018). A common limitation of the large-scale application of these processes is prolonged time and insufficient metal removal. Therefore, synthetic biologists started to tackle the challenges by modifying living organism systems (Capeness and Horsfall, 2020). Increasing heavy metal tolerance in selected strains for bioremediation is a common practice to improve the process rate and efficiency. One of the ways to elevate tolerance is the insertion of resistance genes. Several engineering strategies to increase microorganism tolerance to Cu have lately been introduced (Giachino et al., 2021). Other efforts include finding competent genetic elements necessary for genetic reprogramming, which is severely limited for main metal-eating bacteria (*Acidithiobacillus spp.*). An efficient reporter gene based on luciferase activity that can be applied in all *Acidithiobacillus spp.* to monitor gene expression and regulation has been identified (Chen et al., 2020). Previously researchers have sought other types of microbial chassis, like heterotrophs, cyanobacteria, and methanotrophs, to implement genetic tools (Giachino et al., 2021). The application of synthetic biology toolkits in metal biorecovery is still in its infancy. Further improvement of the above-mentioned microbial processes can present an unprecedented opportunity for green and effective remediation of metal pollution and recycling metals from hazardous solid waste like electronic waste.

- Hydrocarbons

Synthetic biology has a growing impact on the bioremediation of hydrocarbons. Hydrocarbons include polyaromatic hydrocarbons (PAHs), petroleum and its derivatives, hexachlorocyclohexane (HCH), aromatic dyes, chloroalkanes, polychlorinated biphenyls (PCBs), and organohalides (Dangi et al., 2019). Biodegradation enhancement strategies for the compounds like PAHs by GMO involve: finding survival and dissolution genes as well as degradation-related enzyme genes in addition to the adjustment of gene expression, biocatalyst activity increase, and applying new degradation pathways (Sakshi and Haritash, 2020). Recently, synthetic biology tools have been successfully used for the manipulation of gene expression in *E. coli* to optimize aromatic pollutants bioremediation and homologous and heterologous over-expression of nitroalkane-oxidizing enzymes (NOEs) in two thermophilic bacteria (Tang et al., 2018; Zhang et al., 2021). Microorganisms capable of polyurethane (PU) degradation include some bacterial strains like *Comamonas*, *Pseudomonas*, *Bacillus*, *Acinetobacter*, *Corynebacterium*, and fungal species such as *Aspergillus*, *Pestalotiopsis*, *Cladosporium*, *Fusarium*, *Penicillium*. *Aspergillus* species have shown the most promising ability in PU depolymerization (Liu et al., 2021a). Microbial enzymes responsible for PU breakdown mainly include hydrolases type (protease (peptide breakers), esterase, urease, and amidase (amid breakers).



**Table 3**  
The genetically engineered microbes used for bioremediation.

Pollutant	Microorganism	Gene	Effect	ref
Heavy Metal				
U (VI)	<i>Shewanella oneidensis</i> MR-1	<i>mtrB</i> , <i>mtrC</i> , <i>mtrA</i> , <i>omcA</i> , <i>cymA</i> , <i>ribC</i> , <i>ribBA</i> , <i>ribE</i> , <i>ribH</i> , <i>ribD</i> , <i>mdh</i> , <i>fdh</i>	2–6-fold overexpression of <i>mtr</i> genes, a 10-fold increase in flavin synthesis, 234 and a 10-fold increase in <i>fdh</i> and <i>mdh</i> expression 3.6-fold increase in U (VI) bioreduction	(Fan et al., 2021)
As	<i>Thermus thermophilus</i> HB27	<i>TtarsM</i>	Arsenite detoxification	(Gallo et al., 2021)
Cr (VI)	<i>Shewanella oneidensis</i> MR-1	<i>dmsE</i>	38% improvement in Cr reduction	(Li et al., 2020)
Hg	<i>Cupriavidus metallidurans</i> MSR33	<i>merR1TPAGB1</i> , <i>merR2B2D2E</i>	Improved Hg tolerance	(Rojas et al., 2011)
Ni	<i>E. coli</i> JM109	<i>nixA</i> and metallothionein (MT)	6-fold higher Ni bioaccumulation	(Deng et al., 2003)
Hydrocarbon				
Oil sludge	<i>M257E.xiangfangensis</i>	<i>vgrG</i>	2-fold increase in biosurfactant production	(Muneeswari et al., 2022)
Phenol	<i>E. coli</i> BL-phe/cat	<i>pheA1</i> , <i>pheA2</i> , <i>catA</i> , <i>catB</i> , <i>catC</i> , <i>catD</i> , <i>pcaI</i> , <i>pcaJ</i> , <i>pcaF</i>	Sequential conversion of phenol to catechol and acetyl-CoA, overexpression of related genes	(Wang et al., 2019)
Long-chain alkane	<i>E. coli</i> DH5α <i>E. coli</i> BL21 (DE3)	<i>almA</i>	Higher biodegradation rate	(Meng et al., 2018)
3-Methyldiphenylether (MDE)	<i>E. coli</i> BL21 (DE3)	<i>mdeABCD</i>	Methy oxidation of MDE	(Yang et al., 2016)
Plastic				
Polyethylene (PE)	<i>E. coli</i> BL21 pET-PsLAC	<i>inakn</i>	Low-temperature laccase-mediated depolymerization	(Zhang et al., 2023)
Polyethylene terephthalate (PET)	<i>E. coli</i> BL21 (DE3)	DuraPETase (enzyme)	Improved thermal stability of enzyme, 3-fold rise of biodegradation	(Liu et al., 2022)
Polyethylene terephthalate (PET)	<i>I. sakaiensis</i>	IsPETase	Enhanced catalytic activity with fusion to a cellulose-binding domain (CBM) from <i>Trichoderma reesei</i>	(Dai et al., 2021)
poly (ε-caprolactone) (PCL)	<i>Pichia pastoris</i>	lipase-cutinase (enzyme)	bifunctional enzyme overexpression 13-fold higher biodegradation	(Liu et al., 2019b)
Polyethylene terephthalate (PET)	<i>I. sakaiensis</i> 201-F6 PETase	PETase (enzyme)	PETase conversion to cutinase-like structure	(Austin et al., 2018)
Pesticide				
Pyrethroids	<i>E. coli</i>	Esterase Est816 (enzyme)	Enhanced catalytic activity with rational design	(Fan et al., 2023)
Bensulfuron-methyl (BSM)	<i>Methylomonas</i> sp. LW13	<i>sule</i>	Conferring BSM degrading ability	(Liu et al., 2021b)
Carbamates pyrethroids, and organophosphates	<i>Pseudomonas putida</i> KT2440	<i>mpd</i> , <i>pytH</i> , <i>mcd</i> , <i>cehA</i> , <i>vgb</i> , <i>gfp</i>	Simultaneous degradation of three pesticides	(Gong et al., 2018)
γ-Hexachlorocyclohexane and Methyl Parathion	<i>Pseudomonas putida</i> KT2440	<i>mpd</i> , <i>pytH</i>	Simultaneous degradation of two pesticides	(Gong et al., 2016)
Mixture of Organochlorine and Organophosphate	<i>E. coli</i> DH5α <i>E. coli</i> BL21 (DE3)	<i>mpd</i> , <i>linA</i>	7-fold rise in biodegradation	(Yang et al., 2012)
Others				
Azo dye	<i>Shewanella oneidensis</i> MR-1	minCDE, SO_3166	2.5-and 2.9-fold higher power generation and azo dye degradation	(Chen et al., 2022)

#### • Plastics

Microbial decontamination of plastics is an enzyme-driven process conducted by various microorganisms, including actinomycetes, algae, bacteria, and fungi (Amobonye et al., 2021). Different approaches in synthetic biology, such as metagenomics, cloning, and computational methods, have been used to enhance the capability of *Pseudomonas*, *Escherichia*, and *Bacillus* species in enzymatic depolymerization of plastics (Amobonye et al., 2021). Most engineering studies in plastic biodegradation have focused on modifying genes encoding effective degradative enzymes. *Pseudomonas* species were of great help in supplying effective enzymes for cloning in other bacterial hosts (Skariyachan et al., 2021). However, non-bacterial hosts have also attracted notable traction lately. A new study has reported the successful utilization of *Phaeodactylum tricorutum* as an algal genetic host and its low-cost growth conditions for the biodegradation of polyethylene terephthalate (PET) (for more information, see Fig. 9(a)). This was done by expressing a key enzyme (PETase) from *Ideonella sakaiensis* in the genetic host (Moog et al., 2019). PET has been the most studied plastic by bioremediation researchers over the past 20 years due to its challenging depolymerization and difficulty in hydrolyzing. Recently, manipulation of thermostability and activity of a cutinase enzyme resulted in more

than 90% biodegradation (33 times more than previously found enzymes) of a PET bottle sample (Tournier et al., 2020). Catalytic activity improvement was performed using mutagenesis of amino acid residues identified by molecular docking and binding mode analysis. To assess the mechanism by which a microbial community from landfill cleave polyether-polyurethanes (PE)-PU plastics, a new metagenomic approach (proximity ligation-based) was conducted together with physical and chemical analysis (Fig. 9(b)) (Gaytán et al., 2020). The results revealed each species' degradative genes and enzymes, providing insight into how each species enhance and contribute to the biodegradation of plastic. A review paper has provided a list of polyethylene terephthalate (PET) hydrolytic enzymes identified in native strains (Carr et al., 2020).

#### • Pesticides

Different strategies have been examined to improve pesticide bioremediation in recent years. The focus has been on artificially selected communities, taking advantage of adaptive gene loss, metabolic burden division, enzyme engineering, and quorum sensing for enhanced pesticide removal. Different mechanisms and strategies to engineer microbial communities and examples of such systems have been reviewed in detail recently (Bhatt et al., 2020; Liu et al., 2019). In a



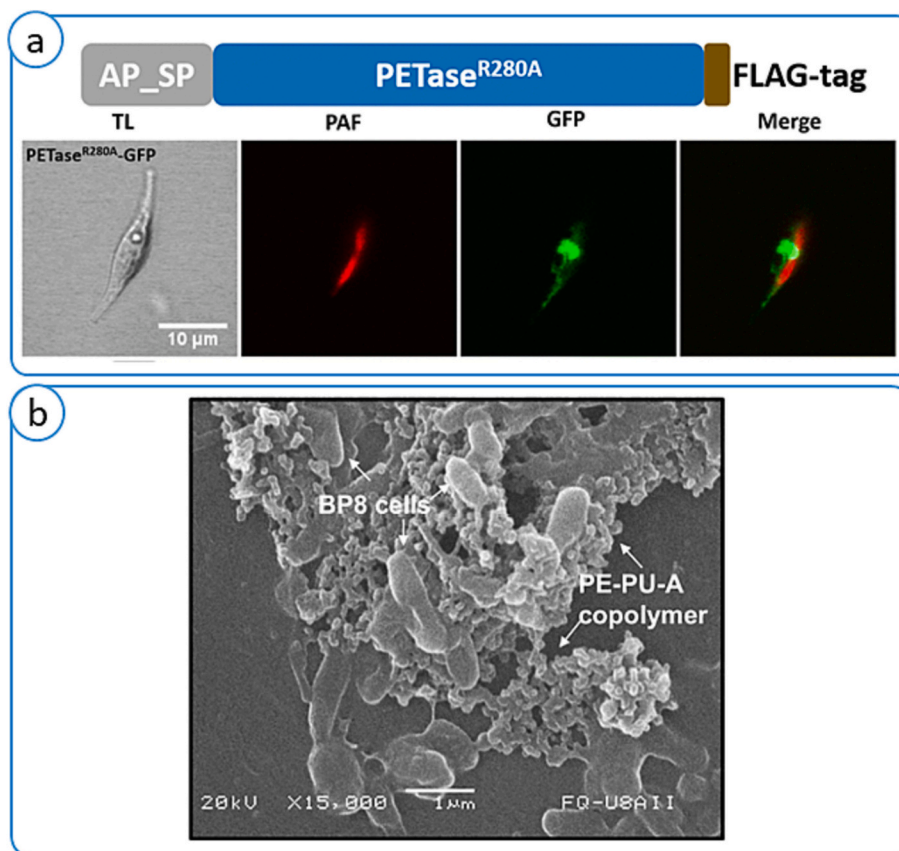

**Fig. 9.** (a) (Upper) Schematic of AP\_SP-PETase-FLAG protein, and (Bottom) Expression of PETase-GFP showing the protein is localized in the ER. The figure was adapted with permission from (Moog et al., 2019). (b) Scanning electron microscopy analysis of BP8 cells attaching to polyether-polyurethane-acrylate after cultivation. The figure was adapted with permission from (Gaytán et al., 2020).

recent investigation, the organophosphate hydrolase (OPH) enzyme was engineered to improve the degradation of organophosphorus compounds (OPCs), a widespread family of pesticides. Site-directed mutagenesis was used to enhance OPH hydrolase stereoselectivity. Engineering methods such as protein fusion, immobilization, and chemical modification have improved catalytic performance, enzyme stability, and substrate affinity (Wang and Sun, 2021). In some cases, a complete biodegradation pathway can be introduced to a new strain. Zhao et al. have achieved the complete removal of  $\gamma$ -hexachlorocyclohexane ( $\gamma$ -HCH) (an organochlorine pesticide) and 1,2,3-trichloropropane (TCP) (a toxic solvent) using a new strategy in biodegradation pathway construction. This involved a combination of pathway assembly by DNA assembler and chromosomal integration by a counterselection system, introduced into *Pseudomonas putida* KT2440 (Zhao et al., 2021). A recent review paper has collected research studies conducted on esterase enzymes, the application of heterologous gene expression to introduce potential esterase from plants and animals into microbes, and their role in biodegradation of OPCs, carbamate, and pyrethroid, three main categories of pesticides (Bhatt et al., 2021b).

#### 4.2. Insects engineering for bioremediation

Insects engineering is one of the latest bioremediation technologies presented as a viable alternative to engineered microbes. Sterilization, a simple and effective method of biosafety control for engineered insects, can provide a safe programmed organism for enhanced bioremediation. The robust digestion system of insects facilitates crude waste valorization without pretreatments and sterilization needs. Facile upscaling, minimum land use, and manageable infrastructure installment are other benefits of this technology. Therefore, using insects as a biological

factory to produce industrially essential biomolecules such as enzymes and lipids has been suggested as an untapped waste valorization opportunity. To assess this idea, a fungal laccase enzyme from *Trametes trogii* was recently expressed in a model insect (*Drosophila melanogaster*). The engineered fly removed 50% of bisphenol A in their feed. Lyophilized powder of transgenic insects could decolorize 90% of indigo carmine in water (Clark et al., 2022). These results indicated the potential of transgenic insects to be used as a new chassis for enzyme production and *in-situ* bioremediation.

#### 4.3. Plants and phytoremediation

Plants can transform or eliminate environmental pollutants through a process known as phytoremediation. Numerous heavy metal-contaminated sites can benefit from the use of plant genotypes with increased metal stabilization or extraction capacity for soil remediation and phytoremediation. This procedure uses various techniques, including phytoextraction, phytostabilization, rhizofiltration, and phytovolatilization (Fig. 9). In phytoextraction, the plants extract the heavy metals from the waters, sediments, as well as soils and accumulate them in aboveground parts. Thus, harvesting plants can remove heavy metals from the environment (Ghazaryan et al., 2019). Phytostabilization is the process whereby the heavy metals are immobilized in belowground metal-tolerant plants and decrease their bioavailability in soil (Pérez-Palacios et al., 2017b). In rhizofiltration, plant roots absorb, concentrate, and precipitate the toxic metals from the contaminated water (Pérez-Palacios et al., 2017a). Phytovolatilization is used by plant roots to uptake the contaminant, convert it to a gaseous state, and release it into the atmosphere (Zhang et al., 2017).

In phytoextraction, metal is taken up by plants, moved, and then

concentrated in tissues above ground. Plants that accumulate high levels of heavy metals are known as hyperaccumulators. These hyperaccumulators are widely used for two different classifications of phytoextraction: phytoextraction chelate-assisted or induced phytoextraction, and long-term or continuous phytoextraction (Ghazaryan et al., 2019). Despite significant interest in the application of chelate-assisted phytoextraction using EDTA, utilization of biodegradable chelants, such as asethylenediamine disuccinate (EDDS), with less harm to the environment is proposed (Bian et al., 2018) (Fig. 10(a)), which is beneficial to the degradation of chelants after phytoextraction.

Toxic ions can be maintained in polluted substrates and immobilized in roots during phytostabilization within the rhizosphere. This process can be facilitated by microbial communities like bacterial endophytes in partnership with plants (Ahsan et al., 2017, 2018) (Fig. 10(b)). A composite *Medicago truncatula* plant expressed the *Arabidopsis thaliana* metallothionein gene *mt4a* in roots. In contrast, a *Ensifer medicae* strain expressed *Pseudomonas fluorescens* copper resistance gene *copAB* driven

by *nifH*p, a nodulation promoter, used for inoculation with the plant. This double symbiotic system is an example of Cu rhizophytostabilization (Pérez-Palacios et al., 2017b).

The pollutants in the effluents can also be absorbed, concentrated, and precipitated by the roots during rhizofiltration. Transgenic tobacco hairy roots, for example, expressing the *P. fluorescens CopC* gene (encodes the Cu-binding periplasmic protein *CopC*) and targeting it to the vacuole (CuHR-V), might result in Cu-hyperaccumulator hairy roots with reduced toxicity stress symptoms (Pérez-Palacios et al., 2017a) (Fig. 10(c)). Plant biomass with accumulated toxic metals requires harvesting after phytoextraction and rhizofiltration. Pyrolysis is the most promising thermochemical technique for large-scale heat and energy recovery from heavy metal-contaminated plant biomass (Dastyar et al., 2019). In sufficient amounts, metal-containing combusted plant materials can be used for metal recycling in eco-catalysts, lowering the overall environmental impacts of extracting metals using current mining procedures (Chaney, 2018; Harumain et al., 2017). Then, during

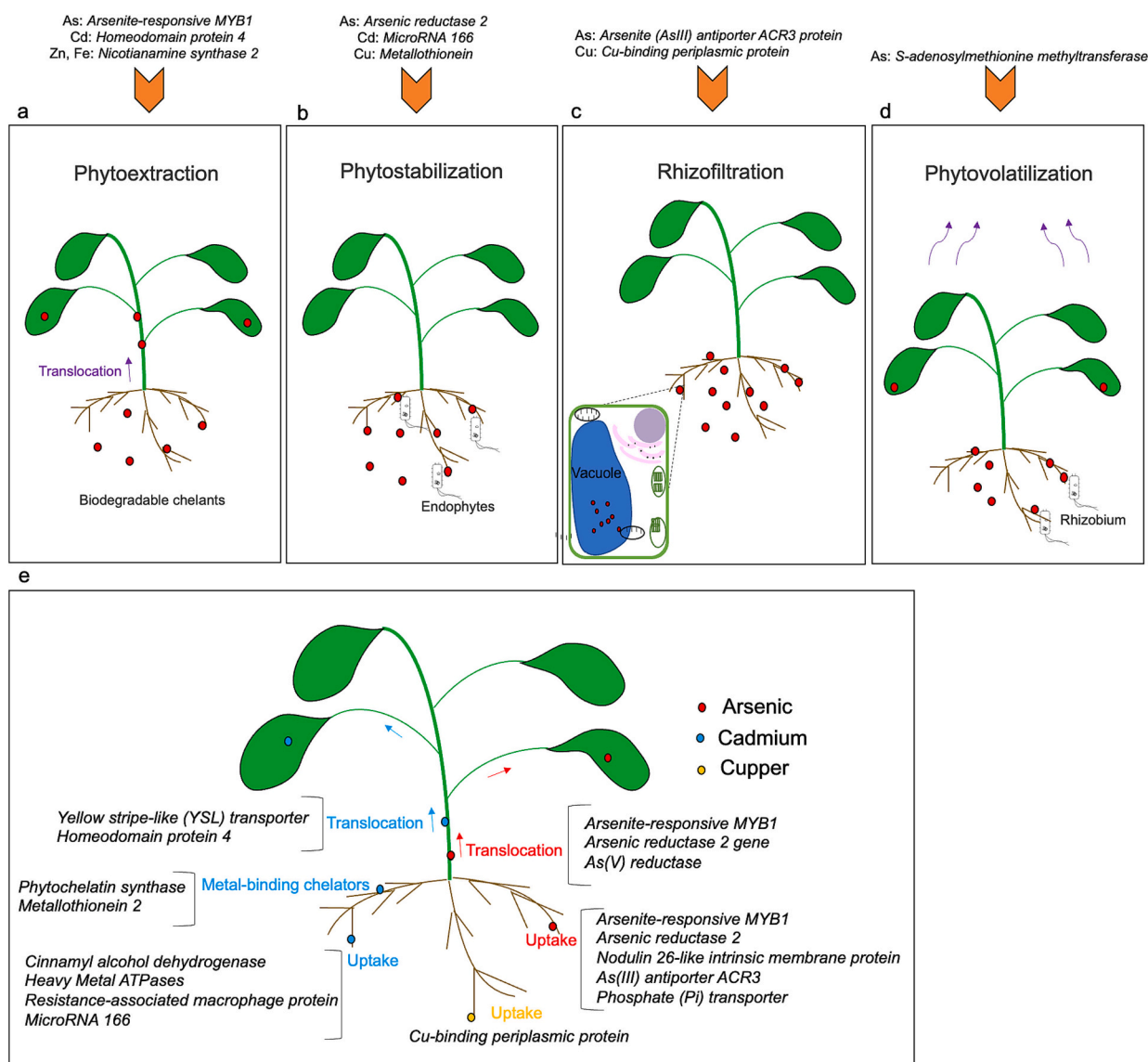

**Fig. 10.** Phytoremediation techniques for treating metal-contaminated sites include phytoextraction, phytostabilization, rhizofiltration, and phytovolatilization. (a) Phytoextraction in the presence of biodegradable chelants, (b) Phytostabilization in the presence of endophytes, (c) Rhizofiltration by sequestering heavy metals into the vacuole, (d) Phytovolatilization in the presence of Rhizobium. Relevant to panel a-d, the genes utilized in different phytoremediation techniques are listed above each technique, and red circles represent the heavy metal pollutants. (e) The genes involved in arsenic (red), cadmium (blue), and copper (yellow) uptake and translocation functions are listed beside each marked function. (For interpretation of the references to color in this figure legend, the reader is referred to the web version of this article.)

volatilization, metals can biologically be converted to gaseous forms by plants and released into the atmosphere. For instance, *Chlamydomonas reinhardtii* As(III) S-adenosylmethionine methyltransferase (*arsM*) gene expressed in rhizobium-legume symbiont revealed methylation and subsequently volatilization of As (Zhang et al., 2017) (Fig. 10(d)). It highlighted the potential use of legume-rhizobia symbionts for As bioremediation.

There are advantages to using phytoremediation, including: (i) it is economically feasible, as it is powered by solar energy; thus, it is simple to manage, and the cost of installation and maintenance is low, (ii) it is environment and eco-friendly while reducing the exposure of the

environment and ecosystem to the pollutants, (iii) it is applicable over a large-scale field, (iv) it prevents metal leaching and erosion while stabilizing the heavy metals, and thereby reducing the risk of spreading contaminants, (v) it can improve soil fertility by releasing organic matters to the soil (Shen et al., 2022). However, several limitations restrict the efficiency of this technology, including: (i) low bioavailability of heavy metals in the soil by, for example, pH, organic matter, oxygen, moisture, and other factors in the soil, (ii) low plant biomass production, and (iii) lack of effective dispose methods for contaminated biomass (Shen et al., 2022). Therefore, choosing the appropriate plants with high growth rates and biomass and strong abilities to absorb and

**Table 4**  
The genetically engineered plants used for phytoremediation.

Pollutant	Plant	Gene	Effect	Ref.
As	<i>Oryza sativa</i>	Arsenite-responsive MYB1 (OsARM1)	Arsenic tolerance, uptake, root-to-shoot translocation	(Wang et al., 2017)
As	<i>Oryza sativa</i>	<i>Nodulin 26-like intrinsic membrane protein (OsNIP3;2)</i>	As uptake by lateral roots	(Chen et al., 2017c)
As	<i>Arabidopsis thaliana</i>	<i>Arsenic reductase 2 (AtACR2)</i>	As accumulation in root	(Nahar et al., 2017)
As	<i>Oryza sativa</i>	<i>As(V) reductase (OsHAC4)</i>	As(V) reduction, As(III) efflux	(Xu et al., 2017)
As	<i>Oryza sativa</i>	<i>Phosphate transporter (OsPT4)</i>	AsV uptake and translocation	(Cao et al., 2017)
As	<i>Pteris vittata</i>	<i>Arsenite (AsIII) antiporter ACR3 protein</i>	As accumulation in roots, sequestering As (III) into vacuoles	(Chen et al., 2017b)
As	<i>Arabidopsis thaliana</i>	Vacuolar phosphate transporter (AtVPT1)	As accumulation	(Luan et al., 2018)
As	<i>Oryza sativa</i>	<i>Phosphate transporter (OsPT4)</i>	As(V) uptake and transport	(Ye et al., 2017)
Cd	<i>Brassica napus</i>	Phytochelatin synthase	Cd accumulation and translocation	(Bai et al., 2019)
Cd	<i>Vicia sativa</i>	<i>Phytochelatin synthases (PCS1)</i>	Increased PCs-chelated Cd in the cytosol	(Zhang et al., 2018)
Cd, Zn	<i>Morus notabilis</i>	MnPCS1 and MnPCS2	Zn <sup>2+</sup> /Cd <sup>2+</sup> accumulation	(Fan et al., 2018)
Cd	<i>Prosopis juliflora</i>	<i>Heavy metal ATPases (PjHMT)</i>	Cd <sup>2+</sup> accumulation	(Keeran et al., 2017)
Cd	<i>Sedum alfredii</i>	<i>Natural resistance-associated macrophage protein (SaNramp6)</i>	Cd <sup>2+</sup> accumulation	(Chen et al., 2017a)
Cd	<i>Suaeda salsa</i>	<i>Metallothionein 2 (SsMT2)</i>	Cd <sup>2+</sup> accumulation	(Jin et al., 2017)
Cd	<i>Sedum alfredii</i>	<i>Cinnamyl alcohol dehydrogenase (SaCAD)</i>	Cd <sup>2+</sup> accumulation in cell wall	(Qiu et al., 2018)
Cd	<i>Miscanthus sacchariflorus</i>	<i>Yellow stripe-like (MsYSL1)</i>	Higher Cd, Fe, and Mn translocation ratios	(Chen et al., 2018)
Cu, Cd	<i>Physcomitrella patens</i>	<i>Metallothioneins 2</i>	Tolerance to high concentrations of CuSO <sub>4</sub> and CdCl <sub>2</sub>	(Liu et al., 2020)
Cd	<i>Sedum plumbizincicola</i>	<i>Metallothionein-like protein</i>	Cd accumulation and tolerance	(Peng et al., 2017)
Cd	<i>Oryza sativa</i>	<i>Homeodomain containing protein4 (OsHB4)</i>	Cd sensitivity and accumulation in the leaves and grains	(Ding et al., 2018)
Cu	<i>Pseudomonas fluorescens</i>	<i>Cu-binding periplasmic protein (CopC)</i>	Targeted to the vacuole, Cu-hyperaccumulation in hairy roots with alleviated toxicity	(Pérez-Palacios et al., 2017a)
Hg	<i>Populus trichocarpa</i>	<i>ATP-binding cassette transporter gene (PtABCC1)</i>	Hg accumulation	(Sun et al., 2018)
V, Pb	<i>Arabidopsis</i>	<i>ATP sulfurylase</i>	Tolerance and metal uptake, Pb(NO <sub>3</sub> ) <sub>2</sub> , CdSO <sub>4</sub> , CuSO <sub>4</sub> , NiSO <sub>4</sub> , Na <sub>3</sub> VO <sub>4</sub>	(Kumar et al., 2019)
Zn, Fe	<i>Oryza sativa</i>	<i>Nicotianamine synthase 2</i>	Zn and Fe accumulation in grains	(Singh et al., 2017)
Zn, Fe	<i>AtNAS</i> and <i>AtFRD3</i> from <i>A. thaliana</i> , <i>PvFER</i> from <i>Phaseolus vulgaris</i>	<i>Nicotianamine synthase 1 (AtNAS1)</i> , <i>transporter loading xylem with citrate-iron complex (AtFRD3)</i> , <i>ferritin (PvFER)</i>	Zn and Fe accumulation in grains	(Wu et al., 2018)
Herbicide isoproturon	Human	Cytochrome (P450-1A2)	Metabolize the herbicide isoproturon	(Azab et al., 2020)
Herbicide linuron	Human	Cytochrome (P450-1A2)	Tolerance and detoxification of linuron	(Azab et al., 2018)
Herbicide chlortoluron	<i>Panax ginseng</i>	Cytochrome (PgCYP76B93)	Phytoremediation of the herbicide chlortoluron	(Jang et al., 2020)
Herbicide chlortoluron, isoproturon	<i>P. ginseng</i>	Cytochrome (CYP736A12)	Chlortoluron and isoproturon tolerance	(Khanom et al., 2019)
Herbicide acetochlor	<i>Sphingomonas wittichii</i> DC-6	The oxygenase component, <i>CndA</i> , of the bacterial acetochlor <i>N</i> -dealkylase system, <i>CndABC</i>	Degradation, tolerance to acetochlor	(Chu et al., 2020)

Cd: Cadmium, Cu: Copper, Fe: Iron, Pb: lead, V: Vanadium, Zn: Zinc.

accumulate heavy metals would be the critical element for an efficient phytoremediation process (see Table 4). Furthermore, the advancements in genetic engineering speed up the development of phytoremediation technology, as we discuss the following.

- Genes involved in the phytoremediation of different heavy metals

Genetically modified plants with overexpressed or inactivated genes involved in metal absorption, transport, and sequestration can possess increased phytoremediation capabilities. Metal uptake from the soil via roots, complex formation with ligands and chelators, deposition in vacuoles, and long-distance transport to shoots are all potential mechanisms that can be controlled to increase metal accumulation in plant tissues. Metal transporters and metal-binding chelators are the most commonly employed genes for manipulating plant metal metabolism; nevertheless, in the following section, we will also review other genes involved in phytoremediation, which are classified by their application.

**Arsenic phytoremediation.** In response to As stress, plants sequester it into vacuoles, which are then moved from the roots to the shoots (Deng et al., 2018; Wang et al., 2017). Knockout of Arsenite-responsive MYB1 transcription factor (*OsARM1*) (CRISPR/Cas9-generated mutant) can improve tolerance to As(III), but the overexpression increased sensitivity to As(III). When the As(III) concentration is low (2 M), more As is transported from the roots to the shoots in the *OsARM* mutant, whereas when the As(III) concentration is high (25 M), roots collect more As in the *OsARM1* overexpressed line (Wang et al., 2017), implying that the *OsARM1* transcription factor regulates As uptake and root-to-shoot translocation in rice. The arsenic reductase 2 gene (*AtACR2*) from *A. thaliana* introduced into the tobacco genome (*Nicotiana tabacum*, var. Sumsun) reduced the arsenic content in the soil. While the arsenic content was significantly higher in the roots of transgenic plants than that of wild-type (WT) plants (Nahar et al., 2017). Moreover, mutation of As(V) reductase (*OsHAC4*) in rice plants could reduce the As(V) retention in roots, As(III) efflux, and accumulation of As in shoots. However, the opposite was true when rice overexpressed it. Thus, *OsHAC4* detoxifies As(V) by As(V) reduction, followed by As(III) efflux (Xu et al., 2017). Moreover, due to the similarity of phosphate (Pi) chemistry and As(V), soil As(V) could enter the plant cells mainly through the plasma membrane phosphate (Pi) transporters (Luan et al., 2018; Ye et al., 2017). A major vacuolar phosphate transporter in *A. thaliana* (*AtVPT1*) is involved in As(V) tolerance while contributing to vacuolar Pi sequestration (Luan et al., 2018). The Nodulin 26-like intrinsic membrane protein *OsNIP3;2* was shown to be involved in As(III) uptake by lateral roots. However, its contribution to the accumulation of As in the shoots was limited (Chen et al., 2017c). Yanshan Chen et al. expressed As(III) antiporter *ACR3* (*PvACR3;1*) in *A. thaliana* and *Nicotiana tabacum*. The transgenic *A. thaliana* resulted in higher As retention in roots but less in shoots than WT. Thus, *PvACR3;1* can boost As retention in roots while reducing As in shoots and/or grains by sequestering As(III) into vacuoles.

**Cadmium phytoremediation.** Plants and certain microbes contain phytochelatin, which are enzymatically produced from glutathione in the presence of heavy metals via phytochelatin synthases activity. The phytochelatin synthase (PCS) genes were discovered to be particularly efficient in heavy metal phytoremediation (Bai et al., 2019; Fan et al., 2018; Zhang et al., 2018). These findings enrich the original model of Cd detoxification mediated by phytochelatin synthases in higher plants. In another study, *Brassica napus* phytochelatin synthase gene was transformed into *A. thaliana* *AtPCS1* mutant *cad1-3* indicating a highly efficient transgenic line efficient in Cd remediation (Bai et al., 2019). *Vicia sativa* PCS gene (*VsPCS1*) could retain Cd in the cytosol rather than the vacuole (Zhang et al., 2018). Fan et al. identified two *Morus alba* phytochelatin synthase genes and transformed them into *A. thaliana* and *N. tabacum* (Zhang et al., 2018). The concentration of  $Zn^{2+}/Cd^{2+}$  in both shoots and roots of transgenic seedlings of *Arabidopsis* was higher than WT. Thus, they are suggested as promising genetic resources for heavy

metals phytoremediation. Metallothioneins are low molecular weight cysteine-rich proteins/polypeptides found in a wide range of organisms and plants that maintain cellular homeostasis through binding with essential or non-essential metals (Fasani et al., 2018). *SsMT2*, a type 2 metallothionein gene from *Suaeda salsa*, a salt- and alkali-tolerant plant, was cloned to *A. thaliana* and accumulated more  $Cd^{2+}$  but less  $Na^{+}$  (Jin et al., 2017).

The yellow stripe-like (YSL) family of transporters transferring metal ions chelated with phytosiderophore or nicotianamine (NA) are involved in the uptake, translocation, and distribution of various mineral elements. *Arabidopsis* overexpressing *Miscanthus sacchariflorus* yellow stripe-like (*MsYSL1*) gene showed resistance to Cd. It was accompanied by longer root length, lower levels of Cd, Zn, and Mn in roots, and higher Cd, Fe, and Mn translocation ratios under Cd stress conditions (Chen et al., 2018). Thus, *MsYSL1* involved in transporting diverse metal-NAs could participate in the Cd detoxification while mediating the reallocation of other metal ions. Transgenic *A. thaliana* expressing *Sedum alfredii* metal transporter natural resistance-associated macrophage protein (*SaNramp6*) also exhibited high Cd accumulation levels (Chen et al., 2017a). Transgenic tobacco plants constitutively expressing *Prosopis juliflora* heavy metal ATPases (*PjHMT*), an ATP-driven heavy metal pump, accumulated and tolerated Cd efficiently (Keeran et al., 2017). Cinnamyl alcohol dehydrogenase (CAD) catalyzing the final step in the phenylpropanoid lignin biosynthetic pathway is involved in the stress resistance process. Overexpression of *Sedum alfredii* cinnamyl alcohol dehydrogenase in *Arabidopsis* increased the tolerance and accumulation of Cd by the absorption and fixation of Cd to lignified cell walls during stress conditions (Qiu et al., 2018). Therefore, besides phytochelatin synthase, metallothioneins, and transporters, the genes involved in lignin biosynthesis are useful for Cd remediation.

**Mercury phytoremediation.** The genetic transformation of plants with ATP-binding cassette (ABC) family genes can impact heavy metal mobility; thereby, overexpression of ABC genes in plants can enhance the translocation of metals such as Hg. Hg is a highly biotoxic heavy metal contaminant in the environment. Overexpression of the *Populus trichocarpa* ATP-binding cassette (ABC) transporter gene (*PtABCC1*) can improve Hg tolerance and accumulation in *Arabidopsis* and poplar (Sun et al., 2018).

- Genes involved in phytoremediation of herbicides

Excessive usage of herbicides may lead to many environmental issues. Cytochrome P450 enzymes are members of a superfamily that also includes heme monooxygenases. P450s play a role in metabolizing a wide range of endogenous substrates. The cytochrome P450 enzymes were discovered to have unique biological applications in herbicide phytoremediation. The herbicide isoproturon was metabolized by human cytochrome P450-1A2 expressed in *A. thaliana*. Meanwhile, WT growth was considerably hampered by isoproturon at doses greater than 50 M (Azab et al., 2020). Interestingly, the expression of human *P450-1A2* in *A. thaliana* can also enhance the linuron herbicide tolerance and detoxification (Azab et al., 2018). In addition to the functionality of human P450s in phytoremediation, overexpression of *Panax ginseng* *CYP76B93* in *A. thaliana* can improve resistance to the herbicide chlorotoluron (Jang et al., 2020). Furthermore, when the ginseng-derived *CYP736A12* was overexpressed in *A. thaliana*, it was implicated in chlortoluron and isoproturon tolerance (Khanom et al., 2019).

Acetochlor, a widely used herbicide, can be degraded and tolerated by transgenic *A. thaliana* synthesizing CndA, the oxygenase component of CndABC, which is the acetochlor *N*-dealkylase system in the bacteria. The metabolite of the CndA-catalyzed acetochlor *N*-dealkylation process was discharged outside of the cell and might be degraded further by soil microorganisms (Chu et al., 2020). Overall, using cytochrome P450s for phytoremediation of herbicide residues in water and soil could be beneficial.



## 5. Model-based tools for environmental synthetic biology

Computational methods running in conjunction with synthetic biology approaches have found different applications in bioremediation studies. Manipulation of biodegradative pathways has been introduced as one of the most promising ways to improve the ability of microbes to decontaminate wastes at large scales (Sanghvi et al., 2020). Several fields of science are often involved in these types of research studies, such as genomics, proteomics, bioinformatics, molecular modeling, and molecular dynamics simulation. Common *in silico* techniques in bioremediation are molecular docking of enzymes and pollutants, molecular dynamics simulation, and *in silico* toxicology (Balan et al., 2021; Bhatt et al., 2021a; Singh et al., 2020). The University of Minnesota has compiled a list of 543 bacterial strains with their associated degrading pollutant (Gao et al., 2010). This type of database can be helpful, especially for *in silico* simulations and choosing the right bioremediation strategy.

Synthetic biology utilizes various molecular and computational technologies to produce enzymes that match industry standards. To maximize gene expression and protein production, regulatory and genetic elements, e.g., promoter, terminator, and binding sequences, can be engineered to influence microbial metabolism (Carr et al., 2020). Molecular docking is also used in bioremediation studies to explore favorable interactions between the pollutant and enzyme binding site, forming stable complexes with minimum binding energy. While molecular docking itself is not considered part of synthetic biology, it plays a role in guiding the design of bioremediation strategies. A list of various molecular docking and biodegradation pathway prediction software has been provided before (Singh et al., 2020).

Synthetic biology and metabolic engineering have significantly contributed to bioremediation process development (Liang et al., 2020; Plewniak et al., 2018). They are areas where we can improve the production of various chemicals used as biodegrading agents (Sharma et al., 2019). Efforts in environmental synthetic biology need to be directed to systems biology tools, particularly metabolic models. Environmental systems biology provides invaluable information about interactions within the networks of microbial communities in different ecosystems under different conditions. This information has become more attractive with the advances in omics data and genomic methods, which are culture-independent. Using culture-independent techniques, such as metagenomics and metatranscriptomics, researchers can directly analyze genetic material from environmental samples and capture a broader range of microbial diversity, including previously unculturable species. This comprehensive understanding of the microbial community's composition and dynamics allows for a more accurate assessment of bioremediation processes. This enables researchers to develop simulation models for predicting the biodegradation of specific pollutants more effectively and design strategies for constructing microbial consortia tailored to the bioremediation of a given substance. The use of culture-independent data in environmental systems biology thus empowers the advancement of bioremediation processes by providing a more comprehensive, accurate, and ecologically relevant understanding of microbial interactions and functions within natural ecosystems.

So far, scientists using traditional approaches have often overlooked the potential of high-throughput technologies and have thus failed to gain mechanistic insights into microbial communities and identifying their functions. High-throughput data including proteomics (Nzila et al., 2018), fluxomics (Zhang et al., 2020), metabolomics (Jain and Chen, 2018), and transcriptomics (Pinel-Cabello et al., 2021; Sengupta et al., 2019) integrated with genomics and metagenomics (Guerra et al., 2018) hold promise for performing more comprehensive studies to reveal the underlying mechanisms of microorganisms involved in bioremediation processes. A recent review paper has provided a detailed list of different genomic and transcriptomics technologies as well as proteomic and metabolomic tools that have been used over the years for pesticide bioremediation (Rodríguez et al., 2020). This is where machine learning

approaches can guide our perception regarding the available data. Different bioremediation processes have used various methods, including deep neural nets, radial basis functions, multi-layer perceptron, and decision trees (Gupta et al., 2021).

As a constraint-based model, flux balance analysis (FBA) is widely used *in silico* to analyze genome-scale metabolic networks. By maximizing a desired objective function, such as the flux of a specific reaction within the network, FBA predicts the optimal flux distribution of metabolic reactions under given environmental conditions using linear programming (Aminian-Dehkordi et al., 2020). It utilizes genome-scale metabolic models (GEMs) to consider the stoichiometry of metabolic reactions and constraints such as nutrient availability or energy production rate. GEMs serve as the foundation for FBA by comprehensively representing the metabolic network and its associated cellular functions, unraveling genotype-phenotype associations in different microorganisms and even consortiums.

In the context of bioremediation, constraint-based models can help identify potential biodegradation pathways and predict the growth rate and efficiency of microbial communities involved in pollutant degradation. They can be used to design optimized microbial consortia for efficient bioremediation of specific pollutants by predicting the cross-feeding interactions among different microbial species (Said et al., 2020; Scott Jr et al., 2023). Integrating high-throughput data with constraint-based modeling makes FBA a crucial tool for understanding and optimizing bioremediation processes in different ecosystems. For instance, GEMs of *Pseudomonas putida* have been instrumental in identifying essential genes and pathways for degrading a wide range of pollutants, aiding in designing optimized microbial consortia for efficient bioremediation (Lewis et al., 2020b; Nogales et al., 2008; Yuan et al., 2017). GEMs of *Bacillus megaterium* have elucidated the essential metabolic pathways involved in cyanide production, contributing to understanding its bioremediation potential for gold leaching from telecommunication printed circuit boards waste (Aminian-Dehkordi et al., 2020). Furthermore, GEMs of cyanobacteria have been employed to engineer strains for efficient pollutant degradation (Norena-Caro et al., 2021). A list of generated GEMs for different organisms involved in various bioremediation processes is provided in Table 5.

Based on the principles applied to FBA, models have been developed to optimize microbial strains. Computational tools, including but not limited to OptKnock (Burgard et al., 2003), OptStrain (Pharkya et al., 2004), and OptReg (Pharkya and Maranas, 2006), can be used for metabolic engineering in bioremediation. OptKnock focuses on gene deletion strategies for specific bioremediation processes. In contrast, OptStrain adopts a gene mining approach, extracting valuable genes from diverse strains and integrating them into specific GEMs to construct an optimized microbial strain with enhanced bioremediation

**Table 5**  
Presented genome-scale metabolic models for different organisms involved in bioremediation processes.

Organism	Objective	Model name	Reference
<i>Paenarthrobacter aureus</i>	Atrazine bioremediation	iRZ1179	(Dangi et al., 2019) (Aminian-Dehkordi et al., 2019)
<i>Bacillus megaterium</i>	Cyanide bioleaching	iJA1121	(Lewis et al., 2020b; Nogales et al., 2020; Zhao et al., 2021)
<i>Pseudomonas putida</i>	Evolution of the biodegradation capacity, Breakdown of plastic wastes	iJN1462	(Koduru et al., 2020)
<i>Xanthomonas oryzae</i>	Antimicrobial targets identification	iXO0673	(Huang and Lin, 2020)
<i>Pseudomonas fluorescens</i>	Bioremediation of petroleum aromatic hydrocarbon (PAH)	iCW1057	(Coppens et al., 2023)
<i>Vibrio natriegens</i>	A salt-induced bioremediation	iLC858	

capabilities. On the other hand, OptReg enables researchers to manipulate gene regulation, positively or negatively, to fine-tune metabolic pathways and enzymatic activities involved in a bioremediation process. Researchers can tailor microbial strains to achieve superior biodegradation capabilities by employing these computational tools, making bioremediation processes more effective and sustainable.

In case of the availability of rigorous data, GEMs can be used to describe complex cellular behavior precisely. In this regard, it is vital to reconstruct well-established metabolic networks. Despite the development of several automatic and semi-automatic reconstruction and gap-filling algorithms (Aite et al., 2018; Karlsen et al., 2018; Machado et al., 2018; Wang et al., 2018), none of them could match the benefits of manual refinement so far. Therefore, it is always recommended to perform a manual curation process before publishing a GEM (Norsigian et al., 2020).

Various tools and databases have been developed to study the metabolic pathways involved in bioremediation. These tools help in generating robust and accurate models of bioremediation. <sup>13</sup>C metabolic flux analysis accompanied by isotope labeling experiments is another potent strategy for identifying intracellular bottlenecks of genome-scale networks. Zhang et al. (Zhang et al., 2020) revealed the importance of the TCA cycle and ED pathway in the aerobic denitrification and carbon removal process by *Paracoccus denitrificans* Z195. Using <sup>13</sup>C MFA, strategies can be defined to investigate the association between carbon conversion and carbon availability to overproduce a desired metabolite during bioremediation (Sun et al., 2020).

Mathematical modeling and computational biology not only have significant roles in understanding the metabolism of microorganisms, but they can also guide researchers in defining appropriate strategies in different aspects of synthetic biology experiments. After the development of the automated bio-model selection system (BMSS) to recognize transient dynamic behaviors of gene circuits (Yeoh et al., 2019), a new Python package, BMSS2, has been introduced, which facilitates model selection and development for synthetic biology research regarding the DBTL cycle (Ngo et al., 2021). Protein Sequence Activity Relationship (ProSAR) models are computational tools that link the protein sequence to its activity or fitness (Wang et al., 2019). They can assist in enzyme engineering to improve the efficiency of detoxifying enzymes in myco-toxin bioremediation. In addition, several bioinformatic frameworks are available to study and interpret different omics data (Santiago et al., 2019).

New fields such as molecular dynamics simulation, *in silico* toxicology, molecular modeling and docking are being used in metabolic engineering to improve the efficiency of the process. Molecular docking techniques can help predict the fate of a pollutant at its biodegradation stage (Basharat et al., 2019). These tools can also be used to design strategies for constructing a synthetic microbial consortium. With the help of such tools, we can improve our microorganisms' efficiency and produce higher-quality chemical compounds.

## 6. Prospects

Synthetic biology has demonstrated its capacity to revolutionize fields of environmental sciences, and many ongoing efforts are being made to address challenges and develop reliable and effective biological systems. To overcome the difficulties associated with biosensor sensitivity and stability, it is suggested that different machine-learning tools be used to explore new patterns in order to improve biosensor performance. It has also been reported that using nanomaterials improves biosensor stability (Purohit et al., 2020). A significant bottleneck in bioremediation is the limited range of pollutants that current strategies can degrade. Moreover, bioremediation can be slow and inefficient, making it impractical for some applications, and bioaugmentation can help to overcome these limitations by introducing exogenous microorganisms into contaminated environments. Metagenomic research can also help speed up the identification of novel enzymes and

microorganisms. Thus, integrating *in silico* approaches with experimental methods would be critical for producing more robust results. Phytoremediation is constrained in terms of effectiveness and scalability due to the relatively slow growth of plants, which is compounded by the limited availability of suitable plant species and the unpredictable gene expressions in plants. To deal with the challenge, new genome editing technologies and the integration of computational modeling and high-throughput data are required.

Although critical challenges remain to be addressed, synthetic biology can potentially address and limit environmental damage while transforming it into environmental safety and sustainability. More outstanding efforts will be required to accelerate the transition to synthetic biology approaches from current conventional methods. Because most environmental damage takes a long time to manifest, investments in environmental remediation should be made with a long-term perspective in mind. We expect to engineer more microorganisms and plants to sense, quantify, and target specific environmental pollutants more efficiently as efforts to develop synthetic biology methods intensify.

## Declaration of Competing Interest

None.

## Acknowledgment

This study was supported by a grant from the Novo Nordisk Foundation [NNF200C0064547].

## References

- Ahsan, M.T., Najam-ul-haq, M., Idrees, M., Ullah, I., Afzal, M., 2017. Bacterial endophytes enhance phytostabilization in soils contaminated with uranium and lead. *Int. J. Phytoremediation* 19, 937–946. <https://doi.org/10.1080/15226514.2017.1303813>.
- Ahsan, M.T., Najam-ul-haq, M., Saeed, A., Mustafa, T., Afzal, M., 2018. Augmentation with potential endophytes enhances phytostabilization of Cr in contaminated soil. *Environ. Sci. Pollut. Res.* 25, 7021–7032. <https://doi.org/10.1007/s11356-017-0987-x>.
- Aite, M., Chevallier, M., Frioux, C., Trotter, C., Got, J., Cortés, M.P., Mendoza, S.N., Carrier, G., Dameron, O., Guillaudeux, N., Latorre, M., Loira, N., Markov, G.V., Maass, A., Siegel, A., 2018. Traceability, reproducibility and wiki-exploration for “à-la-carte” reconstructions of genome-scale metabolic models. *PLoS Comput. Biol.* 14, e1006146. <https://doi.org/10.1371/JOURNAL.PCBL1006146>.
- Ali, S.S., Al-Tohamy, R., Xie, R., El-Sheekh, M.M., Sun, J., 2020. Construction of a new lipase- and xylanase-producing oleaginous yeast consortium capable of reactive azo dye degradation and detoxification. *Bioresour. Technol.* 313, 123631. <https://doi.org/10.1016/j.biortech.2020.123631>.
- Aminian-Dehkordi, J., Mousavi, S.M., Jafari, A., Mijakovic, I., Marashi, S.A., 2019. Manually curated genome-scale reconstruction of the metabolic network of bacillus megaterium DSM319. *Sci. Rep.* 9, 1–14. <https://doi.org/10.1038/s41598-019-55041-w>.
- Aminian-Dehkordi, J., Mousavi, S.M., Marashi, S.-A., Jafari, A., Mijakovic, I., 2020. A systems-based approach for cyanide overproduction by bacillus megaterium for gold bioleaching enhancement. *Front. Bioeng. Biotechnol.* 0, 528. <https://doi.org/10.3389/FBIOE.2020.00528>.
- Amobonye, A., Bhagwat, P., Singh, S., Pillai, S., 2021. Plastic biodegradation: frontline microbes and their enzymes. *Sci. Total Environ.* 759, 143536. <https://doi.org/10.1016/j.scitotenv.2020.143536>.
- Arias-Sánchez, F.I., Vessman, B., Mitri, S., 2019. Artificially selecting microbial communities: if we can breed dogs, why not microbiomes? *PLoS Biol.* 17. <https://doi.org/10.1371/journal.pbio.3000356>.
- Asemoloye, M.D., Marchisio, M.A., Gupta, V.K., Pecoraro, L., 2021. Genome-based engineering of ligninolytic enzymes in fungi. *Microb. Cell Factories* 20, 1–18. <https://doi.org/10.1186/s12934-021-01510-9>.
- Austin, H.P., Allen, M.D., Donohoe, B.S., Rorrer, N.A., Kearns, F.L., Silveira, R.L., Pollard, B.C., Dominick, G., Duman, R., El Omari, K., 2018. Characterization and engineering of a plastic-degrading aromatic polyesterase. *Proc. Natl. Acad. Sci.* 115, E4350–E4357.
- Azab, E., Kebeish, R., Hegazy, A.K., 2018. Expression of the human gene CYP1A2 enhances tolerance and detoxification of the phenylurea herbicide linuron in *Arabidopsis thaliana* plants and *Escherichia coli*. *Environ. Pollut.* 238, 281–290. <https://doi.org/10.1016/j.envpol.2018.03.025>.
- Azab, E., Hegazy, A.K., Gobouri, A.A., Elkesh, A., 2020. Impact of transgenic *arabidopsis thaliana* plants on herbicide isoproturon phytoremediation through expressing human cytochrome P450-1A2. *Biol. (Basel)* 9, 1–14. <https://doi.org/10.3390/biology9110362>.

- Bai, J., Wang, X., Wang, R., Wang, J., Le, S., Zhao, Y., 2019. Overexpression of three duplicated BnPCS genes enhanced Cd accumulation and translocation in Arabidopsis thaliana mutant cad1-3. *Bull. Environ. Contam. Toxicol.* 102, 146–152. <https://doi.org/10.1007/s00128-018-2487-1>.
- Balan, B., Dhauraniya, A.S., Varma, D.A., Sodhi, K.K., Kumar, M., Tiwari, M., Singh, D.K., 2021. Microbial biofilm ecology, in silico study of quorum sensing receptor-ligand interactions and biofilm mediated bioremediation. *Arch. Microbiol.* 203, 13–30. <https://doi.org/10.1007/S00203-020-02012-9/FIGURES/12>.
- Basharat, Z., Bibi, M., Yasmin, A., 2019. Implications of molecular docking assay for bioremediation. *Data Anal. Med.* 1556–1577 <https://doi.org/10.4018/978-1-7998-1204-3.CH078>.
- Ben Said, S., Tecon, R., Borer, B., Or, D., 2020. The engineering of spatially linked microbial consortia – potential and perspectives. *Curr. Opin. Biotechnol.* 62, 137–145. <https://doi.org/10.1016/j.copbio.2019.09.015>.
- Bhagtaney, L., Sundarajan, P., 2023. An overview of tools for genome editing: ZFNs, mega nucleases, and TALENs. *Cris. Genome Ed. Plants* 37–64.
- Bhatt, P., Bhatt, K., Sharma, A., Zhang, W., Mishra, S., Chen, S., 2020. Biotechnological basis of microbial consortia for the removal of pesticides from the environment. *Crit. Rev. Biotechnol.* 41, 317–338. <https://doi.org/10.1080/07388551.2020.1853032>.
- Bhatt, P., Joshi, T., Bhatt, K., Zhang, W., Huang, Y., Chen, S., 2021a. Binding interaction of glyphosate with glyphosate oxidoreductase and C-P lyase: Molecular docking and molecular dynamics simulation studies. *J. Hazard. Mater.* 409, 124927 <https://doi.org/10.1016/J.JHAZMAT.2020.124927>.
- Bhatt, P., Zhou, X., Huang, Y., Zhang, W., Chen, S., 2021b. Characterization of the role of esterases in the biodegradation of organophosphate, carbamate, and pyrethroid pesticides. *J. Hazard. Mater.* 411, 125026 <https://doi.org/10.1016/j.jhazmat.2020.125026>.
- Bian, X., Cui, J., Tang, B., Yang, L., 2018. Chelant-induced phytoextraction of heavy metals from contaminated soils: a review. *Pol. J. Environ. Stud.* 27, 2417–2424. <https://doi.org/10.15244/pjoes/81207>.
- Bokade, P., Gaur, V.K., Tripathi, V., Bobate, S., Manickam, N., Bajaj, A., 2023. Bacterial remediation of pesticide polluted soils: exploring the feasibility of site restoration. *J. Hazard. Mater.* 441, 129906.
- Borchert, E., Hammerschmidt, K., Hentschel, U., Deines, P., 2021. Enhancing microbial pollutant degradation by integrating eco-evolutionary principles with environmental biotechnology. *Trends Microbiol.* xx, 1–11. <https://doi.org/10.1016/j.tim.2021.03.002>.
- Braddick, D., Ramarohetra, R.F., 2020. Emergent challenges for CRISPR: biosafety, biosecurity, patenting, and regulatory issues. In: *Genome Engineering via CRISPR-Cas9 System*. Elsevier, pp. 281–307.
- Breaker, R.R., Atilho, R.M., Malkowski, S.N., Nelson, J.W., Sherlock, M.E., 2017. The biology of free guanidine as revealed by riboswitches. *Biochemistry* 56 (2), 345–347.
- Brown, N.L., Stoyanov, J.V., Kidd, S.P., Hobman, J.L., 2003. The MerR family of transcriptional regulators. *FEMS Microbiol. Rev.* 27, 145–163. [https://doi.org/10.1016/S0168-6445\(03\)00051-2](https://doi.org/10.1016/S0168-6445(03)00051-2).
- Brutesco, C., Prévéral, S., Escoffier, C., Descamps, E.C.T., Prudent, E., Cayron, J., Dumas, L., Riquebourg, M., Adryanczyk-Perrier, G., de Groot, A., Garcia, D., Rodrigue, A., Pignol, D., Ginot, N., 2017. Bacterial host and reporter gene optimization for genetically encoded whole cell biosensors. *Environ. Sci. Pollut. Res.* 24, 52–65. <https://doi.org/10.1007/s11356-016-6952-2>.
- Bulich, A.A., Isenberg, D.L., 1981. Use of the luminescent bacterial system for the rapid assessment of aquatic toxicity. *ISA Trans.* 20, 29–34.
- Burgard, A.P., Pharkya, P., Maranas, C.D., 2003. OptKnock: a bilevel programming framework for identifying gene knockout strategies for microbial strain optimization. *Biotechnol. Bioeng.* 84 (6), 647–657. <https://doi.org/10.1002/bit.10803>.
- Cameron, D.E., Bashor, C.J., Collins, J.J., 2014. A brief history of synthetic biology. *Nat. Rev. Microbiol.* 125 (12), 381–390. <https://doi.org/10.1038/nrmicro3239>.
- Cao, Y., Sun, D., Ai, H., Mei, H., Liu, X., Sun, S., Xu, G., Liu, Y., Chen, Y., Ma, L.Q., 2017. Knocking out OsPT4 gene decreases arsenate uptake by rice plants and inorganic arsenic accumulation in rice grains. *Environ. Sci. Technol.* 51, 12131–12138. <https://doi.org/10.1021/acs.est.7b03028>.
- Capeness, M.J., Horsfall, L.E., 2020. Synthetic biology approaches towards the recycling of metals from the environment. *Biochem. Soc. Trans.* 48, 1367–1378. <https://doi.org/10.1042/BST20190837>.
- Carlson, E.D., Gan, R., Hodgman, C.E., Jewett, M.C., 2012. Cell-free protein synthesis: applications come of age. *Biotechnol. Adv.* 30, 1185–1194. <https://doi.org/10.1016/j.biotechadv.2011.09.016>.
- Carr, C.M., Clarke, D.J., Dobson, A.D.W., 2020. Microbial polyethylene terephthalate hydrolases: current and future perspectives. *Front. Microbiol.* 11, 1–23. <https://doi.org/10.3389/fmicb.2020.571265>.
- Catur Utomo, R.N.N., Li, W.J.J., Tiso, T., Eberlein, C., Doeker, M., Heipieper, H.J.J., Jupke, A., Wierckx, N., Blank, L.M.M., Utomo, R.N.C., Li, W.J.J., Tiso, T., Eberlein, C., Doeker, M., Heipieper, H.J.J., Jupke, A., Wierckx, N., Blank, L.M.M., 2020. Defined microbial mixed culture for utilization of polyurethane monomers. *ACS Sustain. Chem. Eng.* 8, 17466–17474. <https://doi.org/10.1021/acssuschemeng.0c06019>.
- Cayron, J., Prudent, E., Escoffier, C., Gueguen, E., Mandrand-Berthelot, M.A., Pignol, D., Garcia, D., Rodrigue, A., 2017. Pushing the limits of nickel detection to nanomolar range using a set of engineered bioluminescent *Escherichia coli*. *Environ. Sci. Pollut. Res.* 24, 4–14. <https://doi.org/10.1007/s11356-015-5580-6>.
- Chae, D., Lee, J., Lee, N., Park, K., Moon, S.J., Kim, H.H., 2020. Chemical controllable gene drive in drosophila. *ACS Synth. Biol.* 9, 2362–2377. <https://doi.org/10.1021/acssynbio.0c00117>.
- Chaney, R.L., 2018. Nickel in Soils and Plants. CRC Press. <https://doi.org/10.1201/9781315154664>.
- Chang, H., Voyvodic, P.L., Zúñiga, A., Bonnet, J., 2017. Microbially derived biosensors for diagnosis, monitoring and epidemiology. *Microb. Biotechnol.* 10, 1031–1035.
- Chang, C.Y., Osborne, M.L., Bajic, D., Sanchez, A., 2020. Artificially selecting bacterial communities using propagule strategies\*. *Evolution (N. Y.)* 74, 2392–2403. <https://doi.org/10.1111/evo.14092>.
- Chen, S., Han, X., Fang, J., Lu, Z., Qiu, W., Liu, M., Sang, J., Jiang, J., Zhuo, R., 2017a. Sedum alfredii SaNrp6 metal transporter contributes to cadmium accumulation in transgenic Arabidopsis thaliana. *Sci. Rep.* 7, 1–13. <https://doi.org/10.1038/s41598-017-13463-4>.
- Chen, Yanshan, Hua, C.Y., Jia, M.R., Fu, J.W., Liu, X., Han, Y.H., Liu, Y., Rathinasabapathi, B., Cao, Y., Ma, L.Q., 2017b. Heterologous expression of Pteris vittata Arsenite antiporter PvACR3;1 reduces arsenic accumulation in plant shoots. *Environ. Sci. Technol.* 51, 10387–10395. <https://doi.org/10.1021/acs.est.7b03369>.
- Chen, Yi, Sun, S.K., Tang, Z., Liu, G., Moore, K.L., Maathuis, F.J.M., Miller, A.J., McGrath, S.P., Zhao, F.J., 2017c. The Nodulin 26-like intrinsic membrane protein OsNIP3;2 is involved in arsenite uptake by lateral roots in rice. *J. Exp. Bot.* 68, 3007–3016. <https://doi.org/10.1093/jxb/erx165>.
- Chen, H., Zhang, C., Guo, H., Hu, Y., He, Y., Jiang, D., 2018. Overexpression of a Miscanthus sacchariflorus yellow stripe-like transporter MsYSL1 enhances resistance of Arabidopsis to cadmium by mediating metal ion reallocation. *Plant Growth Regul.* 85, 101–111. <https://doi.org/10.1007/s10725-018-0376-6>.
- Chen, X., Liu, Xiuje, Gao, Y., Lin, Jianqiang, Liu, Xiangmei, Pang, X., Lin, Jianqun, Chen, L., 2020. Application of firefly luciferase (Luc) as a reporter gene for the chemoautotrophic and acidophilic Acidithiobacillus spp. *Curr. Microbiol.* 77, 3724–3730. <https://doi.org/10.1007/s00284-020-02195-w>.
- Chen, Y., Niu, X., Cheng, M., Wang, L., Sun, P., Song, H., Cao, Y., 2022. Crispr/dcas9-rpod-mediated simultaneous transcriptional activation and repression in shewanella oneidensis mr-1. *ACS Synth. Biol.* 11, 2184–2192.
- Chu, C., Liu, B., Liu, J., He, J., Lv, L., Wang, H., Xie, X., Tao, Q., Chen, Q., 2020. Phytoremediation of acetochlor residue by transgenic Arabidopsis expressing the acetochlor N-dealkylase from *Sphingomonas wittichii* DC-6. *Sci. Total Environ.* 728, 138687 <https://doi.org/10.1016/j.scitotenv.2020.138687>.
- Clark, M., Tepper, K., Petroll, K., Kumar, S., Sunna, A., Maselko, M., 2022. Bioremediation of industrial pollutants by insects expressing a fungal laccase. *ACS Synth. Biol.* 11, 308–316. <https://doi.org/10.1021/acssynbio.1c00427>.
- Coppens, L., Tschirhart, T., Leary, D.H., Colston, S.M., Compton, J.R., Judson, W., Iv, H., Dana, K.L., Vora, G.J., Bordel, S., Ledesma-Amaro, R., 2023. Vibrio natriegens genome-scale modeling reveals insights into halophilic adaptations and resource allocation. *Mol. Syst. Biol.* e10523 <https://doi.org/10.15252/MSB.202110523>.
- Dai, L., Qu, Y., Huang, J.-W., Hu, Y., Hu, H., Li, S., Chen, C.-C., Guo, R.-T., 2021. Enhancing PET hydrolytic enzyme activity by fusion of the cellulose-binding domain of cellobiohydrolase I from *Trichoderma reesei*. *J. Biotechnol.* 334, 47–50.
- Dangi, A.K., Sharma, B., Hill, R.T., Shukla, P., 2019. Bioremediation through microbes: systems biology and metabolic engineering approach. *Crit. Rev. Biotechnol.* 39, 79–98. <https://doi.org/10.1080/07388551.2018.1500997>.
- Dastyar, W., Raheem, A., He, J., Zhao, M., 2019. Biofuel production using thermochemical conversion of heavy metal-contaminated biomass (HMCB) harvested from phytoextraction process. *Chem. Eng. J.* 358, 759–785. <https://doi.org/10.1016/j.cej.2018.08.111>.
- Dauert, S., Barrett, G., Feliciano, J.S., Shetty, R.S., Shrestha, S., Smith-Spencer, W., 2000. Genetically engineered whole-cell sensing systems: coupling biological recognition with reporter genes. *Chem. Rev.* 100, 2705–2738.
- DeLorenzo, D.M., Rottinghaus, A.G., Henson, W.R., Moon, T.S., 2018. Molecular toolkit for gene expression control and genome modification in *Rhodococcus opacus* PD630. *ACS Synth. Biol.* 7, 727–738. <https://doi.org/10.1021/acssynbio.7b00416>.
- Deng, X., Li, Q.B., Lu, Y.H., Sun, D.H., Huang, Y.L., Chen, X.R., 2003. Bioaccumulation of nickel from aqueous solutions by genetically engineered *Escherichia coli*. *Water Res.* 37, 2505–2511.
- Deng, F., Yamaji, N., Ma, J.F., Lee, S.K., Jeon, J.S., Martinoia, E., Lee, Y., Song, W.Y., 2018. Engineering rice with lower grain arsenic. *Plant Biotechnol. J.* 16, 1691–1699. <https://doi.org/10.1111/pbi.12905>.
- Ding, Y., Gong, S., Wang, Y., Wang, F., Bao, H., Sun, J., Cai, C., Yi, K., Chen, Z., Zhu, C., 2018. MicroRNA166 modulates cadmium tolerance and accumulation in rice. *Plant Physiol.* 177, 1691–1703. <https://doi.org/10.1104/pp.18.00485>.
- Egger, L.A., Park, H., Inouye, M., 1997. Signal transduction via the histidyl-aspartyl phosphorelay. *Genes Cells.* <https://doi.org/10.1046/j.1365-2443.1997.d01311.x>.
- Elcin, E., Öktem, H.A., 2020. Inorganic cadmium detection using a fluorescent whole-cell bacterial bioreporter. *Anal. Lett.* 53, 2715–2733. <https://doi.org/10.1080/00032719.2020.1755867>.
- Engler, C., Kandzia, R., Marillonnet, S., 2008. A one pot, one step, precision cloning method with high throughput capability. *PLoS One* 3, e3647. <https://doi.org/10.1371/journal.pone.0003647>.
- Esvelt, K.M., Smidler, A.L., Catteruccia, F., Church, G.M., 2014. Concerning RNA-guided gene drives for the alteration of wild populations. *Elife* 3, e03401.
- Fabarius, J.T., Wegat, V., Roth, A., Sieber, V., 2021. Synthetic methylotrophy in yeasts: towards a circular bioeconomy. *Trends Biotechnol.* 39, 348–358. <https://doi.org/10.1016/j.tbttech.2020.08.008>.
- Fan, W., Guo, Q., Liu, C.Y., Liu, X., Zhang, M., Long, D., Xiang, Z., Zhao, A., 2018. Two mulberry phytochelatin synthase genes confer zinc/cadmium tolerance and accumulation in transgenic Arabidopsis and tobacco. *Gene* 645, 95–104. <https://doi.org/10.1016/j.gene.2017.12.042>.
- Fan, Y.-Y., Tang, Q., Li, F.-H., Sun, H., Min, D., Wu, J.-H., Li, Y., Li, W.-W., Yu, H.-Q., 2021. Enhanced bioreduction of radionuclides by driving microbial extracellular electron pumping with an engineered CRISPR platform. *Environ. Sci. Technol.* 55, 11997–12008.



- Fan, X., Zhao, M., Wen, H., Zhang, Yanyu, Zhang, Yixin, Zhang, J., Liu, X., 2023. Enhancement degradation efficiency of pyrethroid-degrading esterase (Est816) through rational design and its application in bioremediation. *Chemosphere* 319, 138021.
- Fasani, E., Manara, A., Martini, F., Furini, A., DalCorso, G., 2018. The potential of genetic engineering of plants for the remediation of soils contaminated with heavy metals. *Plant Cell Environ.* 41, 1201–1232. <https://doi.org/10.1111/pce.12963>.
- Frandsen, M.A., Jayakody, L.N., Li, W.J., Wagner, N.J., Cleveland, N.S., Michener, W.E., Hauer, B., Blank, L.M., Wierckx, N., Klebensberger, J., Beckham, G.T., 2018. Engineering *Pseudomonas putida* KT2440 for efficient ethylene glycol utilization. *Metab. Eng.* 48, 197–207. <https://doi.org/10.1016/j.ymben.2018.06.003>.
- French, K.E., Zhou, Z., Terry, N., 2020. Horizontal 'gene drives' harness indigenous bacteria for bioremediation. *Sci. Rep.* 10, 1–11. <https://doi.org/10.1038/s41598-020-72138-9>.
- Furukawa, K., Ramesh, A., Zhou, Z., Weinberg, Z., Vallery, T., Winkler, W.C., Breaker, R.R., 2015. Bacterial riboswitches cooperatively bind Ni<sup>2+</sup> or Co<sup>2+</sup> ions and control expression of heavy metal transporters. *Mol. Cell* 57, 1088–1098.
- Gallo, G., Mouggiakos, I., Bianco, M., Carbonaro, M., Carpentieri, A., Illiano, A., Pucci, P., Bartolucci, S., van der Oost, J., Fiorentino, G., 2021. A hyperthermostable-Cas9 editing tool reveals the role of a unique arsenite methyltransferase in the arsenic resistance system of *Thermus thermophilus* HB27. *MBio* 12, e02813–e02821.
- Ganesh, I., Ravikumar, S., Lee, S.H., Park, S.J., Hong, S.H., 2013. Engineered fumarate sensing *Escherichia coli* based on novel chimeric two-component system. *J. Biotechnol.* 168, 560–566. <https://doi.org/10.1016/j.jbiotec.2013.09.003>.
- Gao, J., Ellis, L.B.M., Wackett, L.P., 2010. The University of Minnesota biocatalysis/biodegradation database: improving public access. *Nucleic Acids Res.* 38, D488–D491. <https://doi.org/10.1093/NAR/GKP771>.
- Gaytán, I., Sánchez-Reyes, A., Burelo, M., Vargas-Suárez, M., Liachko, I., Press, M., Sullivan, S., Cruz-Gómez, M.J., Loza-Tavera, H., 2020. Degradation of recalcitrant polyurethane and xenobiotic additives by a selected landfill microbial community and its biodegradative potential revealed by proximity ligation-based metagenomic analysis. *Front. Microbiol.* 10 <https://doi.org/10.3389/fmicb.2019.02986>.
- Ghazaryan, K.A., Movsesyan, H.S., Minkina, T.M., Sushkova, S.N., Rajput, V.D., 2019. The identification of phytoextraction potential of *Melilotus officinalis* and *Amaranthus retroflexus* growing on copper- and molybdenum-polluted soils. *Environ. Geochem. Health* 43, 1327–1335. <https://doi.org/10.1007/s10653-019-00338-y>.
- Giachino, A., Focarelli, F., Marles-Wright, J., Waldron, K.J., 2021. Synthetic biology approaches to copper remediation: bioleaching, accumulation and recycling. *FEMS Microbiol. Ecol.* 97, 1–14. <https://doi.org/10.1093/femsec/iaa249>.
- Gibson, D.G., Young, L., Chuang, R.Y., Venter, J.C., Hutchison, C.A., Smith, H.O., 2009. Enzymatic assembly of DNA molecules up to several hundred kilobases. *Nat. Methods* 6, 343–345. <https://doi.org/10.1038/nmeth.1318>.
- Gong, T., Liu, R., Zuo, Z., Che, Y., Yu, H., Song, C., Yang, C., 2016. Metabolic engineering of *Pseudomonas putida* KT2440 for complete mineralization of methyl parathion and  $\gamma$ -hexachlorocyclohexane. *ACS Synth. Biol.* 5, 434–442.
- Gong, T., Xu, X., Dang, Y., Kong, A., Wu, Y., Liang, P., Wang, S., Yu, H., Xu, P., Yang, C., 2018. An engineered *Pseudomonas putida* can simultaneously degrade organophosphates, pyrethroids and carbamates. *Sci. Total Environ.* 628, 1258–1265.
- Gräwe, A., Dreyer, A., Vornholt, T., Barteczko, U., Buchholz, L., Drews, G., Linh Ho, U., Eva Jackowski, M., Kracht, M., Lüders, J., Bleckwehl, T., Rositzka, L., Ruwe, M., Wittchen, M., Lutter, P., Müller, K., Kalinowski, J., Gräwe, A., Dreyer, A., Vornholt, T., Barteczko, U., Buchholz, L., Drews, G., Ho, U.L., Jackowski, M.E., Kracht, M., Lüders, J., Bleckwehl, T., Rositzka, L., Ruwe, M., Wittchen, M., Lutter, P., Müller, K., Kalinowski, J., Gräwe, A., Dreyer, A., Vornholt, T., Barteczko, U., Buchholz, L., Drews, G., Linh Ho, U., Eva Jackowski, M., Kracht, M., Lüders, J., Bleckwehl, T., Rositzka, L., Ruwe, M., Wittchen, M., Lutter, P., Müller, K., Kalinowski, J., Gräwe, A., Dreyer, A., Vornholt, T., Barteczko, U., Buchholz, L., Drews, G., Ho, U.L., Jackowski, M.E., Kracht, M., Lüders, J., Bleckwehl, T., Rositzka, L., Ruwe, M., Wittchen, M., Lutter, P., Müller, K., Kalinowski, J., 2019. A paper-based, cell-free biosensor system for the detection of heavy metals and date rape drugs. *PLoS One* 14, e0210940. <https://doi.org/10.1371/journal.pone.0210940>.
- Guerra, A.B., Oliveira, J.S., Silva-Portela, R.C.B., Araújo, W., Carlos, A.C., Vasconcelos, A.T.R., Freitas, A.T., Domingos, Y.S., de Farias, M.F., Fernandes, G.J.T., Agnez-Lima, L.F., 2018. Metagenome enrichment approach used for selection of oil-degrading bacteria consortia for drill cutting residue bioremediation. *Environ. Pollut.* 235, 869–880. <https://doi.org/10.1016/j.envpol.2018.01.014>.
- Guo, Y., Hui, C., Ye, Liu, L., Chen, M., Peng, Huang, H., Ying, 2021. Development of a bioavailable Hg(II) sensing system based on MerR-regulated visual pigment biosynthesis. *Sci. Rep.* 11, 1–13. <https://doi.org/10.1038/s41598-021-92878-6>.
- Gupta, P.K., Yadav, B., Kumar, A., Himanshu, S.K., 2021. Machine learning and artificial intelligence application in constructed wetlands for industrial effluent treatment: advances and challenges in assessment and bioremediation modeling. *Bioremediation Environ. Sustain.* 403–414 <https://doi.org/10.1016/B978-0-12-820524-2.00016-X>.
- Gutiérrez, J.C., Amaro, F., Martín-González, A., 2015. Heavy metal whole-cell biosensors using eukaryotic microorganisms: an updated critical review. *Front. Microbiol.* 6, 48.
- Harumain, Z.A.S., Parker, H.L., Muñoz García, A., Austin, M.J., McElroy, C.R., Hunt, A.J., Clark, J.H., Meech, J.A., Anderson, C.W.N., Ciacci, L., Graedel, T.E., Bruce, N.C., Rylott, E.L., 2017. Toward financially viable phytoextraction and production of plant-based palladium catalysts. *Environ. Sci. Technol.* 51, 2992–3000. <https://doi.org/10.1021/acs.est.6b04821>.
- Hossain, Akbar, Krupnik, Timothy J., Timsina, Jagadish, Golam Mahboob, M., Chaki, Apurbo Kumar, Farooq, M., Bhatt, R., Fahad, S., Hasanuzzaman, M., Hossain, A., Krupnik, T.J., Timsina, J., Mahboob, M.G., Chaki, A.K., 2020. Agricultural land degradation: processes and problems undermining future food security. *Environ. Clim. Plant Veg. Growth* 17–61. [https://doi.org/10.1007/978-3-030-49732-3\\_2](https://doi.org/10.1007/978-3-030-49732-3_2).
- Hu, S., Zhang, G., Jia, X., 2023. Improvement of a highly sensitive and specific whole-cell biosensor by adding a positive feedback amplifier. *Synth. Syst. Biotechnol.* 8, 292–299.
- Huang, X., Lin, Y.-H., 2020. Reconstruction and analysis of a three-compartment genome-scale metabolic model for *Pseudomonas fluorescens*. *Biotechnol. Appl. Biochem.* 67, 133–139. <https://doi.org/10.1002/BAB.1852>.
- Huang, H., Chai, C., Li, N., Rowe, P., Minton, N.P., Yang, S., Jiang, W., Gu, Y., 2016. CRISPR/Cas9-based efficient genome editing in *Clostridium ljungdahlii*, an autotrophic gas-fermenting bacterium. *ACS Synth. Biol.* 5, 1355–1361. <https://doi.org/10.1021/acssynbio.6b00044>.
- Husser, C., Vuilleumier, S., Ryckelynck, M., 2023. FluorMango, an RNA-based fluorogenic biosensor for the direct and specific detection of fluoride. *Small* 19, 2205232.
- Jain, A., Chen, W.N., 2018. Involvement of organic acids and amino acids in ameliorating Ni(II) toxicity induced cell cycle dysregulation in *Caulobacter crescentus*: a metabolomics analysis. *Appl. Microbiol. Biotechnol.* 102, 4563–4575. <https://doi.org/10.1007/S00253-018-8938-0>.
- Jaiswal, S., Shukla, P., 2020. Alternative strategies for microbial remediation of pollutants via synthetic biology. *Front. Microbiol.* <https://doi.org/10.3389/fmicb.2020.00808>.
- Jang, J., Khanom, S., Moon, Y., Shin, S., Lee, O.R., 2020. PgCYP76B93 docks on phenylurea herbicides and its expression enhances chlorotoluron tolerance in *Arabidopsis*. *Appl. Biol. Chem.* 63 <https://doi.org/10.1186/s13765-020-00498-x>.
- Jia, X., Zhao, T., Liu, Y., Bu, R., Wu, K., 2018. Gene circuit engineering to improve the performance of a whole-cell lead biosensor. *FEMS Microbiol. Lett.* 365, 1–8. <https://doi.org/10.1093/femsle/fny157>.
- Jia, X., Bu, R., Zhao, T., Wu, K., 2019. Sensitive and specific whole-cell biosensor for arsenic detection. *Appl. Environ. Microbiol.* 85 (1–10) <https://doi.org/10.1128/AEM.00694-19.e00694-19>.
- Jiang, B., Song, Y., Liu, Z., Huang, W.E., Li, G., Deng, S., Xing, Y., Zhang, D., 2021. Whole-cell bioreporters for evaluating petroleum hydrocarbon contamination. *Crit. Rev. Environ. Sci. Technol.* 51, 272–322.
- Jin, S., Xu, C., Li, G., Sun, D., Li, Y., Wang, X., Liu, S., 2017. Functional characterization of a type 2 metallothionein gene, SsMT2, from alkaline-tolerant *Suaeda salsa*. *Sci. Rep.* 7, 1–11. <https://doi.org/10.1038/s41598-017-18263-4>.
- Jin, S., Bae, J., Song, Y., Pearcy, N., Shin, J., Kang, S., Minton, N.P., Soucaille, P., Cho, B.-K., 2020. Synthetic biology on acetogenic bacteria for highly efficient conversion of C1 gases to biochemicals. *Int. J. Mol. Sci.* <https://doi.org/10.3390/ijms21207639>.
- Jin, L., A., M.E., R., B.S., Ville, S.L.N.E., Suvi, S., Maia, K., 2022. Characterization of highly ferulate-tolerant acetinobacter baylyi ADP1 isolates by a rapid reverse engineering method. *Appl. Environ. Microbiol.* 88 <https://doi.org/10.1128/AEM.01780-21.e01780-21>.
- Jung, J.K., Alam, K.K., Verosloff, M.S., Capdevila, D.A., Desmau, M., Clauer, P.R., Lee, J. W., Nguyen, P.Q., Pastén, P.A., Matiassek, S.J., Gaillard, J.F., Giedroc, D.P., Collins, J. J., Lucks, J.B., 2020. Cell-free biosensors for rapid detection of water contaminants. *Nat. Biotechnol.* 38, 1451–1459. <https://doi.org/10.1038/s41587-020-0571-7>.
- Karlsen, E., Schulz, C., Almaas, E., 2018. Automated generation of genome-scale metabolic draft reconstructions based on KEGG. *BMC Bioinforma* 19, 1–11. <https://doi.org/10.1186/S12859-018-2472-Z>.
- Keeran, N.S., Ganesan, G., Parida, A.K., 2017. A novel heavy metal ATPase peptide from *Prosopis juliflora* is involved in metal uptake in yeast and tobacco. *Transgenic Res.* 26, 247–261. <https://doi.org/10.1007/s11248-016-0002-1>.
- Khanom, S., Jang, J., Lee, O.R., 2019. Overexpression of ginseng cytochrome P450 CYP736A12 alters plant growth and confers phenylurea herbicide tolerance in *Arabidopsis*. *J. Ginseng Res.* 43, 645–653. <https://doi.org/10.1016/j.jgr.2019.04.005>.
- King, J.M.H., Digrazia, P.M., Applegate, B., Burlage, R., Sanseverino, J., Dunbar, P., Larimer, F., Saylor, G.S., 1990. Rapid, sensitive bioluminescent reporter technology for naphthalene exposure and biodegradation. *Science* 249 (80), 778–781. <https://doi.org/10.1126/science.249.4970.778>.
- Koduru, L., Kim, H.Y., Lakshmanan, M., Mohanty, B., Lee, Y.Q., Lee, C.H., Lee, D.-Y., 2020. Genome-scale metabolic reconstruction and in silico analysis of the rice leaf blight pathogen, *Xanthomonas oryzae*. *Mol. Plant Pathol.* 21, 527–540. <https://doi.org/10.1111/MPP.12914>.
- Kumar, V., AlMomin, S., Al-Shatti, A., Al-Aqeel, H., Al-Salameen, F., Shajan, A.B., Nair, S. M., 2019. Enhancement of heavy metal tolerance and accumulation efficiency by expressing *Arabidopsis* ATP sulfurylase gene in alfalfa. *Int. J. Phytoremediation* 21, 1112–1121. <https://doi.org/10.1080/15226514.2019.1606784>.
- Lehmann, M., Riedel, K., Adler, K., Kunze, G., 2000. Amperometric measurement of copper ions with a deputy substrate using a novel *Saccharomyces cerevisiae* sensor. *Biosens. Bioelectron.* 15, 211–219.
- Lewis, L.A., Perisin, M.A., Tobias, A.V., States, C.A.R.L.A.U., 2020. Metabolic Modeling of *Pseudomonas putida* to Understand and Improve the Breakdown of Plastic Waste. *CCDC Army Res. Lab, Adelphi United States*.
- Li, Z., 2018. Health risk characterization of maximum legal exposures for persistent organic pollutant (POP) pesticides in residential soil: an analysis. *J. Environ. Manag.* 205, 163–173. <https://doi.org/10.1016/J.JENVMAN.2017.09.070>.
- Li, J., Tang, Q., Li, Y., Fan, Y.-Y., Li, F.-H., Wu, J.-H., Min, D., Li, W.-W., Lam, P.K.S., Yu, H.-Q., 2020. Redirecting electron flux with an engineered CRISPR-ddAsCpf1 system to enhance the pollutant degradation capacity of *Shewanella oneidensis*. *Environ. Sci. Technol.* 54, 3599–3608.



- Li, Z., Wang, X., Wang, J., Yuan, X., Jiang, X., Wang, Y., Zhong, C., Xu, D., Gu, T., Wang, F., 2022. Bacterial biofilms as platforms engineered for diverse applications. *Biotechnol. Adv.* 57, 107932 <https://doi.org/10.1016/j.biotechadv.2022.107932>.
- Liang, Y., Yu, H., 2021. Genetic toolkits for engineering *Rhodococcus* species with versatile applications. *Biotechnol. Adv.* 49, 107748 <https://doi.org/10.1016/j.biotechadv.2021.107748>.
- Liang, Y., Jiao, S., Wang, M., Yu, H., Shen, Z., 2020. A CRISPR/Cas9-based genome editing system for *Rhodococcus ruber* TH. *Metab. Eng.* 57, 13–22. <https://doi.org/10.1016/j.ymben.2019.10.003>.
- Lin, S., Chen, X.W., Cai, Z., Shi, J., Fu, J., Jiang, G., Wong, M.H., 2022. Remediation of emerging contaminated sites due to uncontrolled e-waste recycling. *Chem. Eng. J.* 430, 133169 <https://doi.org/10.1016/j.cej.2021.133169>.
- Liu, L., Bilal, M., Duan, X., Iqbal, H.M.N., 2019a. Mitigation of environmental pollution by genetically engineered bacteria — current challenges and future perspectives. *Sci. Total Environ.* 667, 444–454. <https://doi.org/10.1016/j.scitotenv.2019.02.390>.
- Liu, M., Zhang, T., Long, L., Zhang, R., Ding, S., 2019b. Efficient enzymatic degradation of poly ( $\epsilon$ -caprolactone) by an engineered bifunctional lipase-cutinase. *Polym. Degrad. Stab.* 160, 120–125.
- Liu, Y., Kang, T., Cheng, J., Shan, Yi, Y., Jun, Han, J., Jie, Cheng, H., Long, Li, Q., Tang, N., Liang, M., Xia, 2020. Heterologous expression of the metallothionein PpMT2 gene from *Physcomitrella patens* confers enhanced tolerance to heavy metal stress on transgenic *Arabidopsis* plants. *Plant Growth Regul.* 90, 63–72. <https://doi.org/10.1007/s10725-019-00558-3>.
- Liu, J., He, J., Xue, R., Xu, B., Qian, X., Xin, F., Blank, L.M., Zhou, J., Wei, R., Dong, W., Jiang, M., 2021a. Biodegradation and up-cycling of polyurethanes: Progress, challenges, and prospects. *Biotechnol. Adv.* 48, 107730 <https://doi.org/10.1016/j.biotechadv.2021.107730>.
- Liu, Y., Zhang, H., He, X., Liu, J., 2021b. Genetically engineered methanotroph as a platform for bioaugmentation of chemical pesticide contaminated soil. *ACS Synth. Biol.* 10, 487–494.
- Liu, Y., Liu, Z., Guo, Z., Yan, T., Jin, C., Wu, J., 2022. Enhancement of the degradation capacity of IsPETase for PET plastic degradation by protein engineering. *Sci. Total Environ.* 834, 154947.
- Luan, M., Liu, J., Liu, Y., Han, X., Sun, G., Lan, W., Luan, S., 2018. Vacuolar phosphate transporter 1 (VPT1) affects arsenate tolerance by regulating phosphate homeostasis in *Arabidopsis*. *Plant Cell Physiol.* 59, 1345–1352. <https://doi.org/10.1093/pcp/pcy025>.
- Machado, D., Andrejev, S., Tramontano, M., Patil, K.R., 2018. Fast automated reconstruction of genome-scale metabolic models for microbial species and communities. *Nucleic Acids Res.* 46, 7542–7553. <https://doi.org/10.1093/NAR/GKY537>.
- Maya, D., Quintero, M.J., de la Cruz Muñoz-Centeno, Chávez, S., 2008. Systems for applied gene control in *Saccharomyces cerevisiae*. *Biotechnol. Lett.* 30, 979–987.
- McCarty, N.S., Ledesma-Amaro, R., 2019. Synthetic biology tools to engineer microbial communities for biotechnology. *Trends Biotechnol.* 37, 181–197. <https://doi.org/10.1016/j.tibtech.2018.11.002>.
- Meng, L., Bao, M., Sun, P., 2018. Construction of long-chain alkane degrading bacteria and its application in bioremediation of crude oil pollution. *Int. J. Biol. Macromol.* 119, 524–532.
- Mirasoli, M., Feliciano, J., Michelini, E., Daunert, S., Roda, A., 2002. Internal response correction for fluorescent whole-cell biosensors. *Anal. Chem.* 74, 5948–5953.
- Moog, D., Schmitt, J., Senger, J., Zarzycki, J., Rexer, K.H., Linne, U., Erb, T., Maier, U.G., 2019. Using a marine microalga as a chassis for polyethylene terephthalate (PET) degradation. *Microb. Cell Factories* 18, 1–15. <https://doi.org/10.1186/s12934-019-1220-z>.
- Moraskie, M., Roshid, M.H.O., O'Connor, G., Dikici, E., Zingg, J.-M., Deo, S., Daunert, S., 2021. Microbial whole-cell biosensors: current applications, challenges, and future perspectives. *Biosens. Bioelectron.* 191, 113359 <https://doi.org/10.1016/j.bios.2021.113359>.
- Moscovici, L., Rieggraf, C., Abu-Rmailah, N., Atias, H., Shakibai, D., Buchinger, S., Reifferscheid, G., Belkin, S., 2020. Yeast-based fluorescent sensors for the simultaneous detection of estrogenic and androgenic compounds, coupled with high-performance thin layer chromatography. *Biosensors* 10, 169.
- Mougiakos, I., Mohanraj, P., Bosma, E.F., Vrouwe, V., Finger Bou, M., Naduthodi, M.I. S., Gussak, A., Brinkman, R.B.L., Van Kranenburg, R., Van Der Oost, J., 2017. Characterizing a thermostable Cas9 for bacterial genome editing and silencing. *Nat. Commun.* 8, 1647.
- Muneswari, R., Iyappan, S., Swathi, K.V., Vinu, R., Ramani, K., Sekaran, G., 2022. Biocatalytic lipoprotein bioamphiphile induced treatment of recalcitrant hydrocarbons in petroleum refinery oil sludge through transposon technology. *J. Hazard. Mater.* 431, 128520.
- Mutschler, H., Gebhardt, M., Shoeman, R.L., Meinhardt, A., 2011. A novel mechanism of programmed cell death in bacteria by toxin-antitoxin systems corrupts peptidoglycan synthesis. *PLoS Biol.* 9, e1001033 <https://doi.org/10.1371/journal.pbio.1001033>.
- Nahar, N., Rahman, A., Nawani, N.N., Ghosh, S., Mandal, A., 2017. Phytoremediation of arsenic from the contaminated soil using transgenic tobacco plants expressing ACR2 gene of *Arabidopsis thaliana*. *J. Plant Physiol.* 218, 121–126. <https://doi.org/10.1016/j.jplph.2017.08.001>.
- Nelson, J.W., Atilho, R.M., Sherlock, M.E., Stockbridge, R.B., Breaker, R.R., 2017. Metabolism of free guanidine in bacteria is regulated by a widespread riboswitch class. *Mol. Cell* 65, 220–230.
- Ngo, R.K.J., Yeoh, J.W., Fan, G.H.W., Loh, W.K.S., Poh, C.L., 2021. BMSS2: a unified database-driven modelling tool for systematic model selection and identifiability analysis. *bioRxiv*. <https://doi.org/10.1101/2021.02.23.432592>, 2021.02.23.432592.
- Nielsen, A.A.K., Voigt, C.A., 2014. Multi-input CRISPR/Cas genetic circuits that interface host regulatory networks. *Mol. Syst. Biol.* 10, 763. <https://doi.org/10.1525/msb.20145735>.
- Nogales, J., Palsson, B.O., Thiele, I., 2008. A genome-scale metabolic reconstruction of *Pseudomonas putida* KT2440: iJN746 as a cell factory. *BMC Syst. Biol.* 2, 1–20.
- Nogales, J., Mueller, J., Gudmundsson, S., Canalejo, F.J., Duque, E., Monk, J., Feist, A. M., Ramos, J.L., Niu, W., Palsson, B.O., 2020. High-quality genome-scale metabolic modelling of *Pseudomonas putida* highlights its broad metabolic capabilities. *Environ. Microbiol.* 22, 255–269. <https://doi.org/10.1111/1462-2920.14843>.
- Norena-Caro, D.A., Zuniga, C., Pete, A.J., Saemundsson, S.A., Donaldson, M.R., Adams, A.J., Dooley, K.M., Zengler, K., Benton, M.G., 2021. Analysis of the cyanobacterial amino acid metabolism with a precise genome-scale metabolic reconstruction of *Anabaena* sp. UTEX 2576. *Biochem. Eng. J.* 171, 108008.
- Norsigian, C.J., Fang, X., Seif, Y., Monk, J.M., Palsson, B.O., 2020. A workflow for generating multi-strain genome-scale metabolic models of prokaryotes. *Nat. Protoc.* 15, 1–14.
- Nzila, A., Ramirez, C.O., Musa, M.M., Sankara, S., Basheer, C., Li, Q.X., 2018. Pyrene biodegradation and proteomic analysis in *Achromobacter xylosoxidans*, PY4 strain. *Int. Biodeterior. Biodegradation* 130, 40–47. <https://doi.org/10.1016/j.ibiod.2018.03.014>.
- Oliferova, L., Statkuc, M., Tsytsin, G., Shpigun, O., Zolotov, Y., 2005. On-line solid-phase extraction and HPLC determination of polycyclic aromatic hydrocarbons in water using fluorocarbon polymer sorbents. *Anal. Chim. Acta* 538, 35–40. <https://doi.org/10.1016/j.aca.2005.01.061>.
- Payer, S.E., Pollak, H., Glueck, S.M., Faber, K., 2018. A rational active-site redesign converts a decarboxylase into a C<sub>2</sub>C hydratase: “tethered acetate” supports enantioselective hydration of 4-Hydroxystyrenes. *ACS Catal.* 8, 2438–2442. <https://doi.org/10.1021/acscatal.7b04293>.
- Peng, J.S., Ding, G., Meng, S., Yi, H.Y., Gong, J.M., 2017. Enhanced metal tolerance correlates with heterotypic variation in SpMTL, a metallothionein-like protein from the hyperaccumulator sedum plumbizincicola. *Plant Cell Environ.* 40, 1368–1378. <https://doi.org/10.1111/pce.12929>.
- Pérez-Palacios, P., Agostini, E., Ibáñez, S.G., Talano, M.A., Rodríguez-Llorente, I.D., Caviedes, M.A., Pajuelo, E., 2017a. Removal of copper from aqueous solutions by rhizofiltration using genetically modified hairy roots expressing a bacterial Cu-binding protein. *Environ. Technol. (U. K.)* 38, 2877–2888. <https://doi.org/10.1080/09593330.2017.1281350>.
- Pérez-Palacios, P., Romero-Aguilar, A., Delgadillo, J., Doukali, B., Caviedes, M.A., Rodríguez-Llorente, I.D., Pajuelo, E., 2017b. Double genetically modified symbiotic system for improved Cu phytostabilization in legume roots. *Environ. Sci. Pollut. Res.* 24, 14910–14923. <https://doi.org/10.1007/s11356-017-9092-4>.
- Pharkya, P., Burgard, A.P., Maranas, C.D., 2004. OptStrain: a computational framework for redesign of microbial production systems. *Genome Res.* 14 (11), 2367–2376. <https://doi.org/10.1101/gr.2872004>.
- Pharkya, P., Maranas, C.D., 2006. An optimization framework for identifying reaction activation/inhibition or elimination candidates for overproduction in microbial systems. *Metab. Eng.* 8 (1), 1–13. <https://doi.org/10.1016/j.ymben.2005.08.003>.
- Phulpoto, I.A., Yu, Z., Qazi, M.A., Ndayisenga, F., Yang, J., 2022. A comprehensive study on microbial-surfactants from bioproduction scale-up toward electrokinetics remediation of environmental pollutants: challenges and perspectives. *Chemosphere* 136979.
- Pinel-Cabello, M., Jroundi, F., López-Fernández, M., Geffers, R., Jarek, M., Jauregui, R., Link, A., Vilchez-Vargas, R., Merroun, M.L., 2021. Multisystem combined uranium resistance mechanisms and bioremediation potential of *Stenotrophomonas bentonitica* BII-R7: Transcriptomics and microscopic study. *J. Hazard. Mater.* 403, 123858 <https://doi.org/10.1016/j.jhazmat.2020.123858>.
- Plewniak, F., Crognale, S., Rossetti, S., Bertin, P.N., 2018. A genomic outlook on bioremediation: the case of arsenic removal. *Front. Microbiol.* 9, 820. <https://doi.org/10.3389/fmicb.2018.00820>.
- Pollmann, K., Kutschke, S., Matys, S., Raff, J., Hlawacek, G., Lederer, F.L., 2018. Bio-recycling of metals: recycling of technical products using biological applications. *Biotechnol. Adv.* 36, 1048–1062. <https://doi.org/10.1016/j.biotechadv.2018.03.006>.
- Potter, D.W., Pawliszyn, J., 1994. Rapid determination of Polyaromatic hydrocarbons and polychlorinated biphenyls in water using solid-phase microextraction and GC/MS. *Environ. Sci. Technol.* 28, 298–305. <https://doi.org/10.1021/es00051a017>.
- Prüss-Ustün, A., Wolf, J., Corvalán, C., Neville, T., Bos, R., Neira, M., 2017. Diseases due to unhealthy environments: an updated estimate of the global burden of disease attributable to environmental determinants of health. *J. Public Health (Bangkok)* 39, 464–475. <https://doi.org/10.1093/PUBMED/FDW085>.
- Purohit, B., Vernekar, P.R., Shetti, N.P., Chandra, P., 2020. Biosensor nanoengineering: design, operation, and implementation for biomolecular analysis. *Sensors Int.* 1, 100040 <https://doi.org/10.1016/J.SINTL.2020.100040>.
- Qin, Q., Ling, C., Zhao, Y., Yang, T., Yin, J., Guo, Y., Chen, G.Q., 2018. CRISPR/Cas9 editing genome of extremophile *Halomonas* spp. *Metab. Eng.* 47, 219–229.
- Qiu, W., Song, X., Han, X., Liu, M., Qiao, G., Zhuo, R., 2018. Overexpression of sedum alfredii cinnamyl alcohol dehydrogenase increases the tolerance and accumulation of cadmium in *Arabidopsis*. *Environ. Exp. Bot.* 155, 566–577. <https://doi.org/10.1016/j.envexpbot.2018.08.003>.
- Ramanathan, S., Ensor, M., Daunert, S., 1997. Bacterial biosensors for monitoring toxic metals. *Trends Biotechnol.* 15, 500–506.
- Ravikumar, S., Yoo, I.K., Lee, S.Y., Hong, S.H., 2011a. Construction of copper removing bacteria through the integration of two-component system and cell surface display. *Appl. Biochem. Biotechnol.* 165, 1674–1681. <https://doi.org/10.1007/S12010-011-9386-9/FIGURES/4>.

- Ravikumar, S., Yoo, I.K., Lee, S.Y., Hong, S.H., 2011b. A study on the dynamics of the *zraP* gene expression profile and its application to the construction of zinc adsorption bacteria. *Bioprocess Biosyst. Eng.* 34, 1119–1126. <https://doi.org/10.1007/S00449-011-0562-7/FIGURES/6>.
- Reynolds, J.L., 2021. Engineering biological diversity: the international governance of synthetic biology, gene drives, and de-extinction for conservation. *Curr. Opin. Environ. Sustain.* 49, 1–6. <https://doi.org/10.1016/J.COSUST.2020.10.001>.
- Roda, A., Roda, B., Cevenini, L., Michellini, E., Mezzanotte, L., Reschiglian, P., Hakkila, K., Virta, M., 2011. Analytical strategies for improving the robustness and reproducibility of bioluminescent microbial bioreporters. *Anal. Bioanal. Chem.* 401, 201–211.
- Rodríguez, A., Castrejón-Godínez, M.L., Salazar-Bustamante, E., Gama-Martínez, Y., Sánchez-Salinas, E., Mussali-Galante, P., Tovar-Sánchez, E., Ortiz-Hernández, M.L., 2020. Omics approaches to pesticide biodegradation. *Curr. Microbiol.* 77, 545–563. <https://doi.org/10.1007/s00284-020-01916-5>.
- Rojas, L.A., Yáñez, C., González, M., Lobos, S., Smalla, K., Seeger, M., 2011. Characterization of the metabolically modified heavy metal-resistant *Cupriavidus metallidurans* strain MSR33 generated for mercury bioremediation. *PLoS One* 6, e17555.
- Rottinghaus, A.G., Ferreira, A., Fishbein, S.R.S., Dantas, G., Moon, T.S., 2022. Genetically stable CRISPR-based kill switches for engineered microbes. *Nat. Commun.* 13, 672. <https://doi.org/10.1038/s41467-022-28163-5>.
- Said, S. Ben, Or, D., 2017. Synthetic microbial ecology: engineering habitats for modular consortia. *Front. Microbiol.* 8 <https://doi.org/10.3389/fmicb.2017.01125>.
- Said, S. Ben, Tecon, R., Borer, B., Or, D., 2020. The engineering of spatially linked microbial consortia—potential and perspectives. *Curr. Opin. Biotechnol.* 62, 137–145.
- Sakshi, Haritash, A.K., 2020. A comprehensive review of metabolic and genomic aspects of PAH-degradation. *Arch. Microbiol.* 202, 2033–2058. <https://doi.org/10.1007/s00203-020-01929-5>.
- Sanghvi, G., Thanki, A., Pandey, S., Singh, N.K., 2020. Engineered bacteria for bioremediation. *Bioremediation Pollutants* 359–374. <https://doi.org/10.1016/b978-0-12-819025-8.00017-x>.
- do N Santiago, C.R., de A B Assis, R., Moreira, L.M., Digiampietri, L.A., 2019. Gene tags assessment by comparative genomics (GTACG): a user-friendly framework for bacterial comparative genomics. *Front. Genet.* 0, 725. <https://doi.org/10.3389/FGENE.2019.00725>.
- Schlembach, I., Hosseinpour Tehrani, H., Blank, L.M., Büchs, J., Wierckx, N., Regestein, L., Rosenbaum, M.A., 2020. Consolidated bioprocessing of cellulose to itaconic acid by a co-culture of *Trichoderma reesei* and *Ustilago maydis*. *Biotechnol. Biofuels* 13, 1–18. <https://doi.org/10.1186/s13068-020-01835-4>.
- Schlembach, I., Grünberger, A., Rosenbaum, M.A., Regestein, L., 2021. Measurement techniques to resolve and control population dynamics of mixed-culture processes. *Trends Biotechnol.* 39, 1093–1109. <https://doi.org/10.1016/j.tibtech.2021.01.006>.
- Scott Jr., W.T., Benito-Vaquero, S., Zimmermann, J., Bajić, D., Heinken, A., Suarez-Diez, M., Schaap, P.J., 2023. A structured evaluation of genome-scale constraint-based modeling tools for microbial consortia. *PLoS Comput. Biol.* 19, e1011363.
- Sengupta, K., Swain, M.T., Livingstone, P.G., Whitworth, D.E., Saha, P., 2019. Genome sequencing and comparative Transcriptomics provide a holistic view of 4-Nitrophenol degradation and concurrent fatty acid catabolism by *Rhodococcus* sp. strain BUPNP1. *Front. Microbiol.* 0, 3209. <https://doi.org/10.3389/FMICB.2018.03209>.
- Sharma, V., Kumar, R., Sharma, V.K., Yadav, A., Kumar, Tiirola, M., Sharma, P.K., 2019. Expression, purification, characterization and in silico analysis of newly isolated hydrocarbon degrading bleomycin resistance dioxygenase. *Mol. Biol. Reports* 47, 533–544. <https://doi.org/10.1007/S11033-019-05159-X>.
- Shaw, W.M., Yamauchi, H., Mead, J., Gowers, G.O.F., Bell, D.J., Öling, D., Larsson, N., Wigglesworth, M., Ladds, G., Ellis, T., 2019. Engineering a model cell for rational tuning of GPCR signaling. *Cell* 177. <https://doi.org/10.1016/j.cell.2019.02.023>, 782–796.e27.
- Shen, X., Dai, M., Yang, J., Sun, L., Tan, X., Peng, C., Ali, I., Naz, I., 2022. A critical review on the phytoremediation of heavy metals from environment: performance and challenges. *Chemosphere* 291, 132979.
- Shetty, R.S., Deo, S.K., Liu, Y., Daunert, S., 2004. Fluorescence-based sensing system for copper using genetically engineered living yeast cells. *Biotechnol. Bioeng.* 88, 664–670. <https://doi.org/10.1002/bit.20331>.
- Silverman, A.D., Akova, U., Alam, K.K., Jewett, M.C., Lucks, J.B., 2020. Design and optimization of a cell-free atrazine biosensor. *ACS Synth. Biol.* 9, 671–677. <https://doi.org/10.1021/acssynbio.9b00388>.
- Singh, S.P., Keller, B., Gruissem, W., Bhullar, N.K., 2017. Rice NICOTIANAMINE SYNTHASE 2 expression improves dietary iron and zinc levels in wheat. *Theor. Appl. Genet.* 130, 283–292. <https://doi.org/10.1007/s00122-016-2808-x>.
- Singh, A.K., Chowdhary, P., Raj, A., 2020. In silico bioremediation strategies for removal of environmental pollutants released from paper mills using bacterial ligninolytic enzymes. *Microorg. Sustain. Environ. Heal.* 249–285 <https://doi.org/10.1016/B978-0-12-819001-2.00013-9>.
- Singh, A.K., Bilal, M., Iqbal, H.M.N., Meyer, A.S., Raj, A., 2021. Bioremediation of lignin derivatives and phenolics in wastewater with lignin modifying enzymes: status, opportunities and challenges. *Sci. Total Environ.* 777 <https://doi.org/10.1016/j.scitotenv.2021.145988>.
- Skariyachan, S., Taskeen, N., Kishore, A.P., Krishna, B.V., Naidu, G., 2021. Novel consortia of *Enterobacter* and *Pseudomonas* formulated from cow dung exhibited enhanced biodegradation of polyethylene and polypropylene. *J. Environ. Manag.* 284, 112030 <https://doi.org/10.1016/J.JENVMAN.2021.112030>.
- Smith, M.T., Hawes, A.K., Shrestha, P., Rainsdon, J.M., Wu, J.C., Bundy, B.C., 2014. Alternative fermentation conditions for improved *Escherichia coli*-based cell-free protein synthesis for proteins requiring supplemental components for proper synthesis. *Process Biochem.* 49, 217–222. <https://doi.org/10.1016/j.procbio.2013.10.012>.
- Sun, Y., Zhao, X., Zhang, D., Ding, A., Chen, C., Huang, W.E., Zhang, H., 2017. New naphthalene whole-cell bioreporter for measuring and assessing naphthalene in polycyclic aromatic hydrocarbons contaminated site. *Chemosphere* 186, 510–518. <https://doi.org/10.1016/j.chemosphere.2017.08.027>.
- Sun, L., Ma, Y., Wang, H., Huang, W., Wang, X., Han, L., Sun, W., Han, E., Wang, B., 2018. Overexpression of PtABC1 contributes to mercury tolerance and accumulation in *Arabidopsis* and poplar. *Biochem. Biophys. Res. Commun.* 497, 997–1002. <https://doi.org/10.1016/j.bbrc.2018.02.133>.
- Sun, H., Ren, Y., Lao, Y., Li, X., Chen, F., 2020. A novel fed-batch strategy enhances lipid and astaxanthin productivity without compromising biomass of *Chromochloris zoffingensis*. *Bioresour. Technol.* 308, 123306 <https://doi.org/10.1016/J.BIORTECH.2020.123306>.
- Tang, Q., Lu, T., Liu, S.J., 2018. Developing a synthetic biology toolkit for *Comamonas testosteroni*, an emerging cellular chassis for bioremediation. *ACS Synth. Biol.* 7, 1753–1762. <https://doi.org/10.1021/acssynbio.7b00430>.
- Tay, P.K.R., Nguyen, P.Q., Joshi, N.S., 2017. A synthetic circuit for mercury bioremediation using self-assembling functional amyloids. *ACS Synth. Biol.* 6, 1841–1850. <https://doi.org/10.1021/acssynbio.7b00137>.
- Tay, P.K.R., Manjula-Basavanna, A., Joshi, N.S., 2018. Repurposing bacterial extracellular matrix for selective and differential abstraction of rare earth elements. *Green Chem.* 20, 3512–3520. <https://doi.org/10.1039/C8GC01355A>.
- Thavarajah, W., Silverman, A.D., Verosloff, M.S., Kelley-Loughnane, N., Jewett, M.C., Lucks, J.B., 2020. Point-of-use detection of environmental fluoride via a cell-free riboswitch-based biosensor. *ACS Synth. Biol.* 9, 10–18. <https://doi.org/10.1021/acssynbio.9b00347>.
- Thorwall, S., Schwartz, C., Chartron, J.W., Wheeldon, I., 2020. Stress-tolerant non-conventional microbes enable next-generation chemical biosynthesis. *Nat. Chem. Biol.* 16, 113–121.
- Tournier, V., Topham, C.M., Gilles, A., David, B., Folgoas, C., Moya-Leclair, E., Kamionka, E., Desrousseaux, M.L., Texier, H., Gavalda, S., Cot, M., Guémar, E., Dalibey, M., Nomme, J., Cioci, G., Barbe, S., Chateau, M., André, I., Duquesne, S., Marty, A., 2020. An engineered PET depolymerase to break down and recycle plastic bottles. *Nature* 580, 216–219. <https://doi.org/10.1038/s41586-020-2149-4>.
- Turco, F., Garavaglia, M., Van Houdt, R., Hill, P., Rawson, F.J., Kovacs, K., 2022. Synthetic biology toolbox, including a single-plasmid CRISPR-Cas9 system to biologically engineer the electrogenic, metal-resistant bacterium *Cupriavidus metallidurans* CH34. *ACS Synth. Biol.* 11, 3617–3628. <https://doi.org/10.1021/acssynbio.2c00130>.
- Volke, D.C., Orsi, E., Nikel, P.I., 2023. Emergent CRISPR-Cas-based technologies for engineering non-model bacteria. *Curr. Opin. Microbiol.* 75, 102353.
- Vopálenská, I., Váňová, L., Palková, Z., 2015. New biosensor for detection of copper ions in water based on immobilized genetically modified yeast cells. *Biosens. Bioelectron.* 72, 160–167. <https://doi.org/10.1016/j.bios.2015.05.006>.
- Voyvodic, P.L., Pandi, A., Koch, M., Conejero, I., Valjent, E., Courtet, P., Renard, E., Faulon, J.L., Bonnet, J., 2019. Plug-and-play metabolic transducers expand the chemical detection space of cell-free biosensors. *Nat. Commun.* 10, 1–8. <https://doi.org/10.1038/s41467-019-09722-9>.
- Wahid, E., Ocheja, O.B., Marsili, E., Guaragnella, C., Guaragnella, N., 2023. Biological and technical challenges for implementation of yeast-based biosensors. *Microb. Biotechnol.* 16, 54–66.
- Wang, L., Sun, Y., 2021. Engineering organophosphate hydrolase for enhanced biocatalytic performance: a review. *Biochem. Eng. J.* 168, 107945 <https://doi.org/10.1016/j.bej.2021.107945>.
- Wang, F.Z., Chen, M.X., Yu, L.J., Xie, L.J., Yuan, L.B., Qi, H., Xiao, M., Guo, W., Chen, Z., Yi, K., Zhang, J., Qiu, R., Shu, W., Xiao, S., Chen, Q.F., 2017. OsARM1, an R2R3 MYB transcription factor, is involved in regulation of the response to arsenic stress in rice. *Front. Plant Sci.* 8, 1–16. <https://doi.org/10.3389/fpls.2017.01868>.
- Wang, H., Marcisauskas, S., Sánchez, B.J., Domenzain, I., Hermansson, D., Agren, R., Nielsen, J., Kerkhoven, E.J., 2018. RAVEN 2.0: a versatile toolbox for metabolic network reconstruction and a case study on *Streptomyces coelicolor*. *PLoS Comput. Biol.* 14, e1006541 <https://doi.org/10.1371/JOURNAL.PCBI.1006541>.
- Wang, B., Xu, J., Gao, J., Fu, X., Han, H., Li, Z., Wang, L., Tian, Y., Peng, R., Yao, Q., 2019. Construction of an *Escherichia coli* strain to degrade phenol completely with two modified metabolic modules. *J. Hazard. Mater.* 373, 29–38.
- Wang, Q., Zhang, J., Al Makishah, N.H., Sun, X., Wen, Z., Jiang, Y., Yang, S., 2021. Advances and perspectives for genome editing tools of *Corynebacterium glutamicum*. *Front. Microbiol.* 12, 1–9. <https://doi.org/10.3389/fmicb.2021.654058>.
- Wu, B., Luo, L., Gao, X.J., 2016. Cas9-triggered chain ablation of cas9 as a gene drive brake. *Nat. Biotechnol.* 34, 137–138. <https://doi.org/10.1038/nbt.3444>.
- Wu, T.Y., Gruissem, W., Bhullar, N.K., 2018. Facilitated citrate-dependent iron translocation increases rice endosperm iron and zinc concentrations. *Plant Sci.* 270, 13–22. <https://doi.org/10.1016/j.plantsci.2018.02.002>.
- Xiao, H., Edwards, T.E., Ferré-D'Amaré, A.R., 2008. Structural basis for specific, high-affinity tetracycline binding by an in vitro evolved aptamer and artificial riboswitch. *Chem. Biol.* 15, 1125–1137.
- Xie, L., Yuan, A.E., Id, W.S., 2019. Simulations Reveal Challenges to Artificial Community Selection and Possible Strategies for Success. <https://doi.org/10.1371/journal.pbio.3000295>.
- Xu, J., Shi, S., Wang, L., Tang, Z., Lv, T., Zhu, X., Ding, X., Wang, Y., Zhao, F.J., Wu, Z., 2017. OsHAC4 is critical for arsenate tolerance and regulates arsenic accumulation in rice. *New Phytol.* 215, 1090–1101. <https://doi.org/10.1111/nph.14572>.

- Yamada, S., Suzuki, Y., Kouzuma, A., Watanabe, K., 2022. Development of a CRISPR interference system for selective gene knockdown in *Acidithiobacillus ferrooxidans*. *J. Biosci. Bioeng.* 133, 105–109.
- Yang, J., Liu, R., Song, W., Yang, Y., Cui, F., Qiao, C., 2012. Construction of a genetically engineered microorganism that simultaneously degrades organochlorine and organophosphate pesticides. *Appl. Biochem. Biotechnol.* 166, 590–598.
- Yang, Q., Cai, S., Dong, S., Chen, L., Chen, J., Cai, T., 2016. Biodegradation of 3-methyldiphenylether (MDE) by *Hydrogenophaga* atypical strain QY7-2 and cloning of the methy-oxidation gene *mdeABCD*. *Sci. Rep.* 6, 39270.
- Ye, Y., Li, P., Xu, T., Zeng, L., Cheng, D., Yang, M., Luo, J., Lian, X., 2017. *Ospt4* contributes to arsenate uptake and transport in rice. *Front. Plant Sci.* 8, 1–12. <https://doi.org/10.3389/fpls.2017.02197>.
- Ye, J.-W., Lin, Y.-N., Yi, X.-Q., Yu, Z.-X., Liu, X., Chen, G.-Q., 2023. Synthetic biology of extremophiles: a new wave of biomanufacturing. *Trends Biotechnol.* 41 (3), 342–357.
- Yeoh, J.W., Ng, K.B.I., Teh, A.Y., Zhang, J., Chee, W.K.D., Poh, C.L., 2019. An automated biomodel selection system (BMSS) for gene circuit designs. *ACS Synth. Biol.* 8, 1484–1497. <https://doi.org/10.1021/ACSSYNBIO.8B00523>.
- Yi, Y.C., Ng, I.S., 2021. Redirection of metabolic flux in *Shewanella oneidensis* MR-1 by CRISPRi and modular design for 5-aminolevulinic acid production. *Bioresour. Bioprocess.* 8 <https://doi.org/10.1186/s40643-021-00366-6>.
- Yuan, Q., Huang, T., Li, P., Hao, T., Li, F., Ma, H., Wang, Z., Zhao, X., Chen, T., Goryanin, I., 2017. Pathway-consensus approach to metabolic network reconstruction for *Pseudomonas putida* KT2440 by systematic comparison of published models. *PLoS One* 12, e0169437.
- Zhang, J., Xu, Y., Cao, T., Chen, J., Rosen, B.P., Zhao, F.J., 2017. Arsenic methylation by a genetically engineered *Rhizobium-legume* symbiont. *Plant Soil* 416, 259–269. <https://doi.org/10.1007/s11104-017-3207-z>.
- Zhang, X., Rui, H., Zhang, F., Hu, Z., Xia, Y., Shen, Z., 2018. Overexpression of a functional *Vicia sativa* PCS1 homolog increases cadmium tolerance and phytochelatin synthesis in *Arabidopsis*. *Front. Plant Sci.* 9, 1–12. <https://doi.org/10.3389/fpls.2018.00107>.
- Zhang, H., Li, S., Ma, B., Huang, T., Qiu, H., Zhao, Z., Huang, X., Liu, K., 2020. Nitrate removal characteristics and 13C metabolic pathways of aerobic denitrifying bacterium *Paracoccus denitrificans* Z195. *Bioresour. Technol.* 307, 123230 <https://doi.org/10.1016/j.biortech.2020.123230>.
- Zhang, B., Sun, L., Song, X., Huang, D., Li, M., Peng, C., Wang, W., 2021. Genetically engineered thermotolerant facultative anaerobes for high-efficient degradation of multiple hazardous nitroalkanes. *J. Hazard. Mater.* 405, 124253 <https://doi.org/10.1016/j.jhazmat.2020.124253>.
- Zhang, A., Hou, Y., Wang, Y., Wang, Q., Shan, X., Liu, J., 2023. Highly efficient low-temperature biodegradation of polyethylene microplastics by using cold-active laccase cell-surface display system. *Bioresour. Technol.* 382, 129164.
- Zhao, R., Liu, Y., Zhang, H., Chai, C., Wang, J., Jiang, W., Gu, Y., 2019. CRISPR-Cas12a-mediated gene deletion and regulation in *Clostridium ljungdahlii* and its application in carbon flux redirection in synthesis gas fermentation. *ACS Synth. Biol.* 8, 2270–2279. <https://doi.org/10.1021/acssynbio.9b00033>.
- Zhao, Y., Che, Y., Zhang, F., Wang, J., Gao, W., Zhang, T., Yang, C., 2021. Development of an efficient pathway construction strategy for rapid evolution of the biodegradation capacity of *Pseudomonas putida* KT2440 and its application in bioremediation. *Sci. Total Environ.* 761, 143239 <https://doi.org/10.1016/j.scitotenv.2020.143239>.
- Zschiedrich, C.P., Keidel, V., Szurmant, H., 2016. Molecular mechanisms of two-component signal transduction. *J. Mol. Biol.* 428, 3752–3775.
- Žunar, B., Mosrin, C., Benedetti, H., Vallée, B., 2022. Re-engineering of CUP1 promoter and Cup2/Ace1 transactivator to convert *Saccharomyces cerevisiae* into a whole-cell eukaryotic biosensor capable of detecting 10 nM of bioavailable copper. *Biosens. Bioelectron.* 214, 114502.