


Spring 1984

# IXTOC I: Case Study of a Major Oil Spill

Peter G. Myer  
*University of Rhode Island*

Follow this and additional works at: [http://digitalcommons.uri.edu/ma\\_etds](http://digitalcommons.uri.edu/ma_etds)

 Part of the [Environmental Law Commons](#), and the [Oceanography and Atmospheric Sciences and Meteorology Commons](#)

---

## Recommended Citation

Myer, Peter G., "IXTOC I: Case Study of a Major Oil Spill" (1984). *Theses and Major Papers*. Paper 133.

This Major Paper is brought to you for free and open access by the Marine Affairs at DigitalCommons@URI. It has been accepted for inclusion in Theses and Major Papers by an authorized administrator of DigitalCommons@URI. For more information, please contact [digitalcommons@etal.uri.edu](mailto:digitalcommons@etal.uri.edu).

IXTOC I: Case Study of a Major Oil Spill

Peter G. Myer  
Marine Affairs Program  
Spring 1984

## INTRODUCTION

The most disastrous oil spill the western hemisphere has ever witnessed occurred during the 10 months between June 1979 and March 1980, when the experimental well IXTOC I blew out off the coast of Mexico's Yucatan Peninsula. The beaches of Mexico's eastern shore suffered the heaviest contamination from the spill while containment efforts and fortunate weather saved the United States' Gulf Coast from the severe contamination many feared, but the combination of dirty beaches and media coverage brought about many tragic economic impacts. The disaster's effects on South Texas virtually destroyed a year's earnings for the region's tourism industry and cut into the profits of many commercial fishermen. On seeking to recover their losses through legal actions, these businessmen and the governments of Texas and the United States found themselves caught in the gap between domestic and international legalities. The United States courts found their jurisdiction severely limited since the accident was brought about by Mexicans, while the State Department found no adequate footing in international law from which to claim financial liability against the Mexican concerns involved. Though not entirely concluded, the litigation to date has left the marine interests of South Texas and the United States Government badly under-compensated for their economic losses. The case bears scrutiny both as an object lesson in the sudden and dire consequences of even so little contamination and as an indicator of major loopholes in our pollution liability laws that need

to be filled. The activities at the well that caused the blowout and subsequent spill, the effects of the oil on Texas' Gulf Coast, and the legal attempts to recover against losses suffered as a result of the spill will be examined.

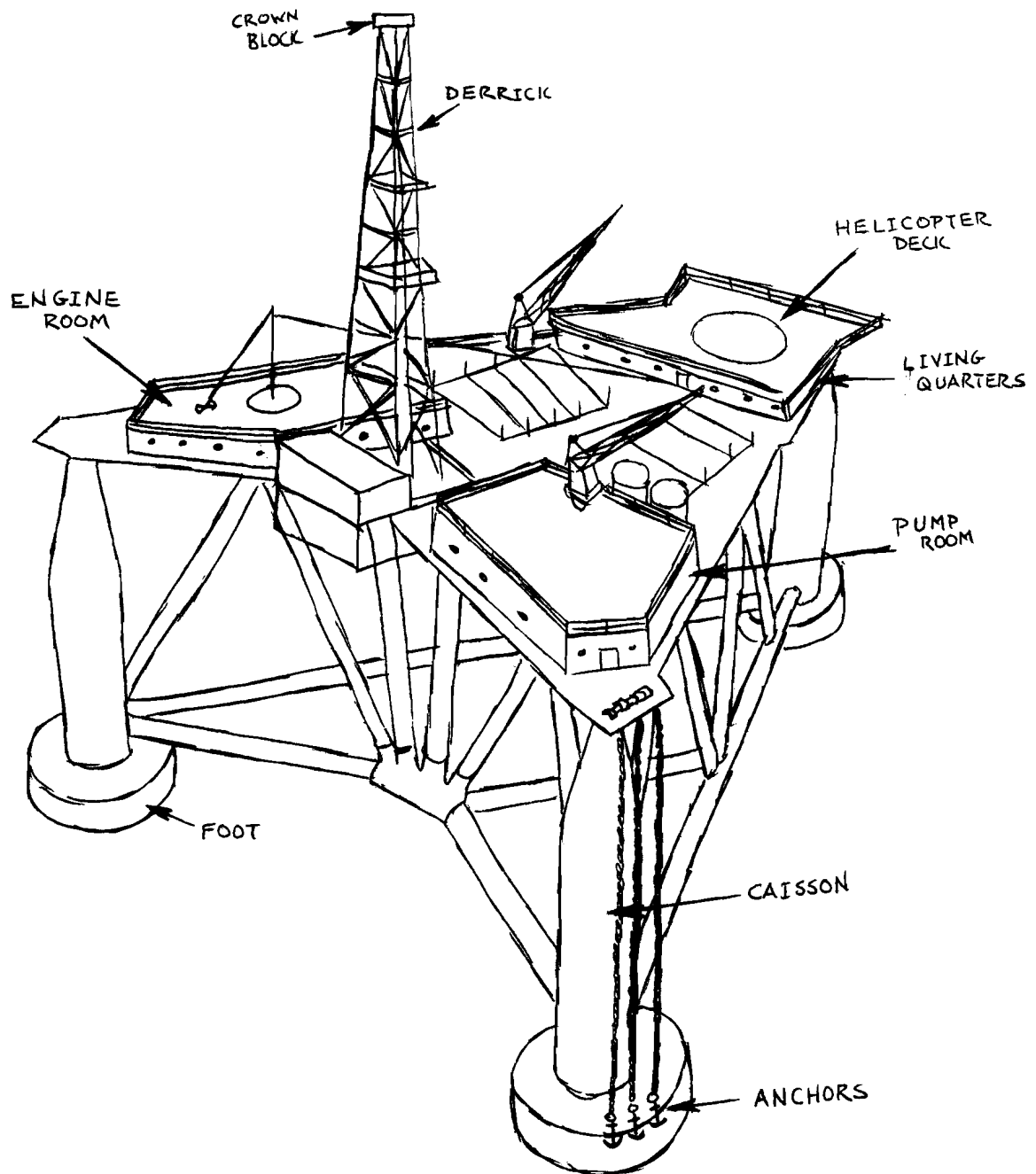
## I. At the Well<sup>1</sup>

### The Platform

The drilling platform designated Sedco 135 was built by the Ingalls Shipyard of Pascagoula, Mississippi in 1965, under contracts from the Southeastern Drilling Company, Inc. (Sedco). It was a 3,527 ton semi-submersible rig with 3 cylindrical caissons for buoyancy while floating or columnar support while resting on the sea floor. A drawing of the platform is provided as Figure 1.

Upon taking delivery of the platform, Sedco attained all licensing and inspections required by the U.S. Coast Guard to place it in service as a merchant vessel in the domestic trade. After 5 years' service in the Gulf of Mexico, Sedco 135 was chartered by foreign concerns, requiring a modification to its license, and towed to coastal west Africa in late 1970 for extended drilling operations. With the rig in foreign waters when the initial Certificate of Inspection expired, re-inspection requirements were waived by the Coast Guard and a temporary Certificate of Registry was issued for the platform in 1971. In 1975, Sedco 135 returned to the Americas and was placed in service to a charterer drilling off Trinidad. In May 1978, a third foreign charter was approved by the U.S. Department of Commerce, this to Perferaciones Marinas del Golfo (Permargo), a Mexican drilling concern under contract to Petroleos Mexicanos (Pemex), the nationalized Mexican oil company. The bareboat charter went into effect in the summer of 1978 and drilling commenced December 1 of that year on the first exploratory well, designated IXTOC I by the Mexicans.

Figure 1: Sedco 135



From Richard E. Ford, USCG, Investigation on "Semi-submersible drill barge SEDCO 135, O.N. 298297; IXTOC-1 well blowout with subsequent fire in the Bay of Campeche, Mexico, in position 19-24N, 92-12W, on 3 June 1979 without personnel injuries, but with major oil pollution.", U.S. Coast Guard serial 16732/3104/REF of 23 April 1981, p.3

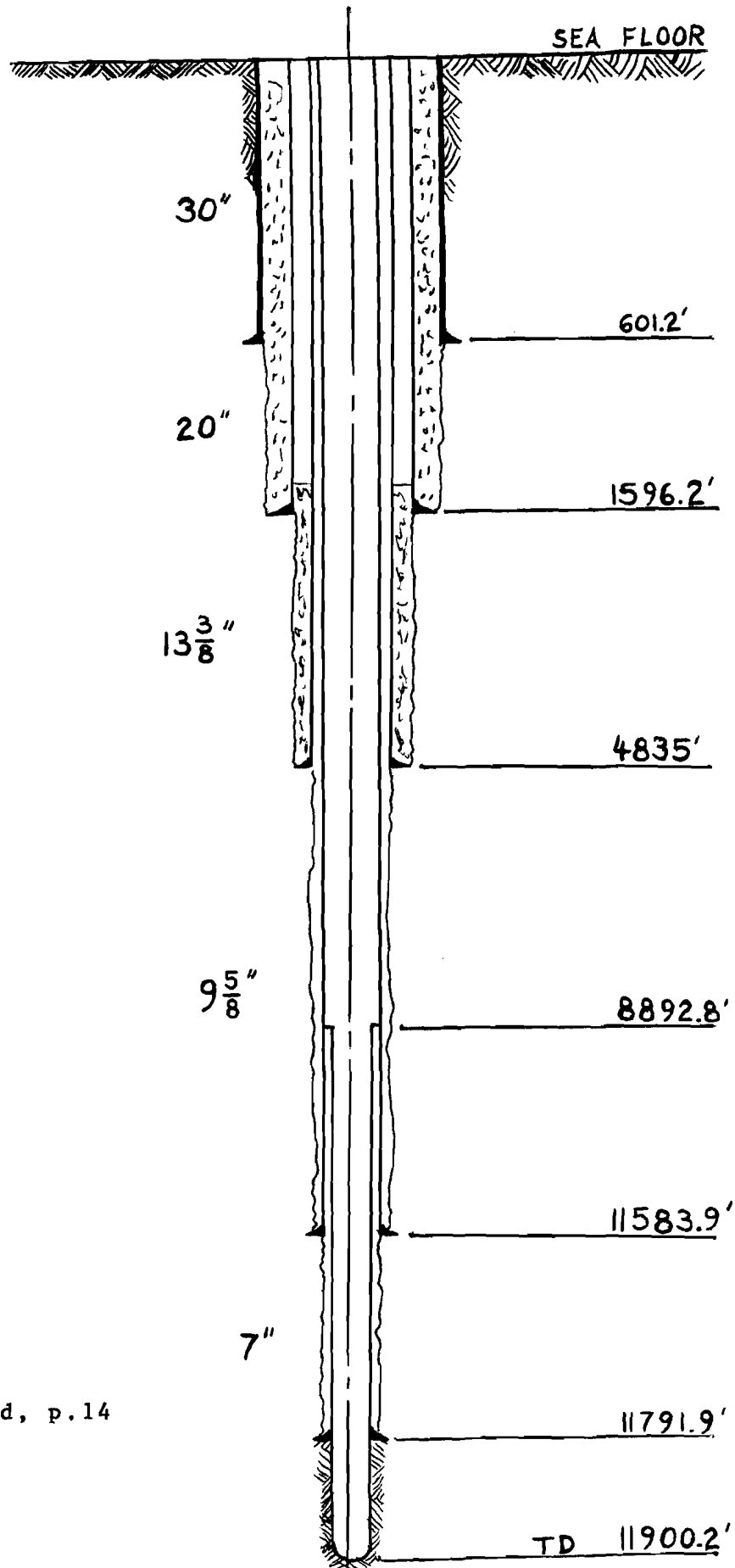
## Drilling Operations

To fully understand the events leading to the blowout of IXTOC I, a brief explanation of some procedures and terminology used in offshore drilling will be required.

To drill a deep well, hollow piping is used as the stem between the platform and the drilling bit. A bit with larger diameter than the piping is attached to a collar, also of larger outside diameter, at the lower end of the drill string. Ninety (90) foot sections of pipe are added as needed by raising one end of the new section to the crown block at the top of the platform's derrick and threading the lower end into the drill string just above the rotary kelly table at the platform's main deck. Piping of decreasing diameter is sunk into the earth to various depths and drilling continues with a smaller bit through the existing casing, making a telescoping drill string as shown in Figure 2. To clean the cutting faces of the bit, a ready-mix mud compound of proper consistency is pumped down the interior of the pipe string, through openings in the center of the bit, and back up the hole around drill string in a continuous flow, as illustrated in Figure 3.

Notice that there is nothing but drilling mud blocking the escape of oil through the drill string should it be encountered unexpectedly. For this purpose, a Blowout Preventer stack is installed below the kelly table; at the sea floor in the case of an offshore well. This equipment has two basic elements, each provided in triplicate for U.S.

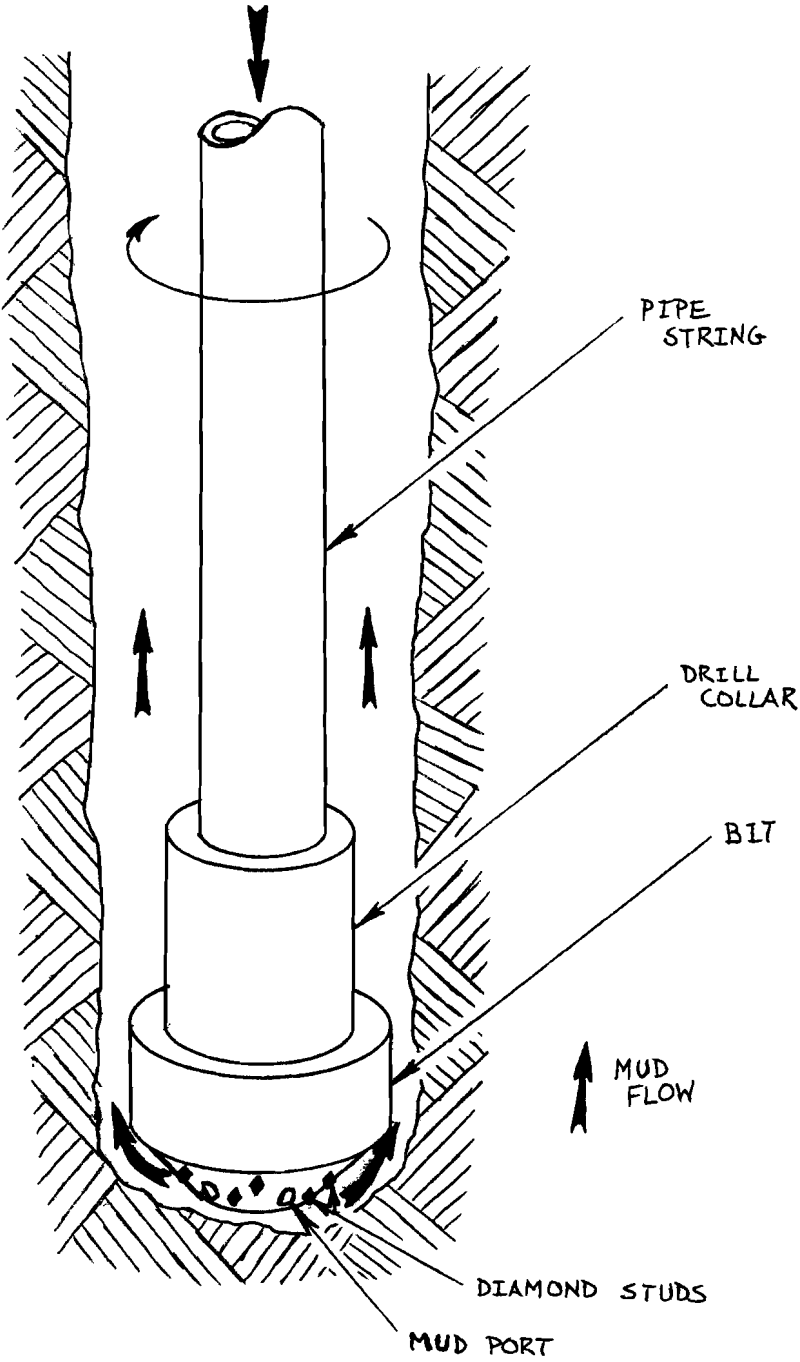
Figure 2: IXTOC I Casing Strings



From Ford, p.14



Figure 3: Drilling Bit



certification as in the case of Sedco 135. The ram shears cut through the pipe string and seal it shut when their explosive propellant is fired; the annular preventer wedges into the space between the drill string and the outermost casing to block the oil's escape there, also using explosive propellant. See Figure 4.

#### The Blowout

The IXTOC I well, as planned by Pemex, was to be a geological exploration to a depth of 18,044 feet. The site was in the Bay of Campeche, off Yucatan, at 19° 24.5' N, 92° 12.5' W, where the water depth is approximately 160 feet. See Figure 5.

By the first of June, 1979, the drilling had reached 11,792 feet, where a seven (7) inch diameter casing ended and a six (6) inch bit on 3 1/2 inch drill pipe was used to drill out the cement plug at the bottom of the casing and continue to greater depths. During the June 1 drilling operations, three losses of mud circulation occurred, requiring retraction to the bottom of the 7" casing at 11,792 feet. After the first two losses, circulation was restored by adding mud and some specially designed lost circulation materials. In trying to stabilize the well after the third loss, the onboard supply of mud compounds was exhausted. At this point, Mr. John Merrel, the senior of seven Sedco advisors constantly on the platform, recommended that the well be filled with sea water and observed for a period of several days. Based on their experience in the vicinity of the site and

Figure 4: Blowout Preventer (Schematic)

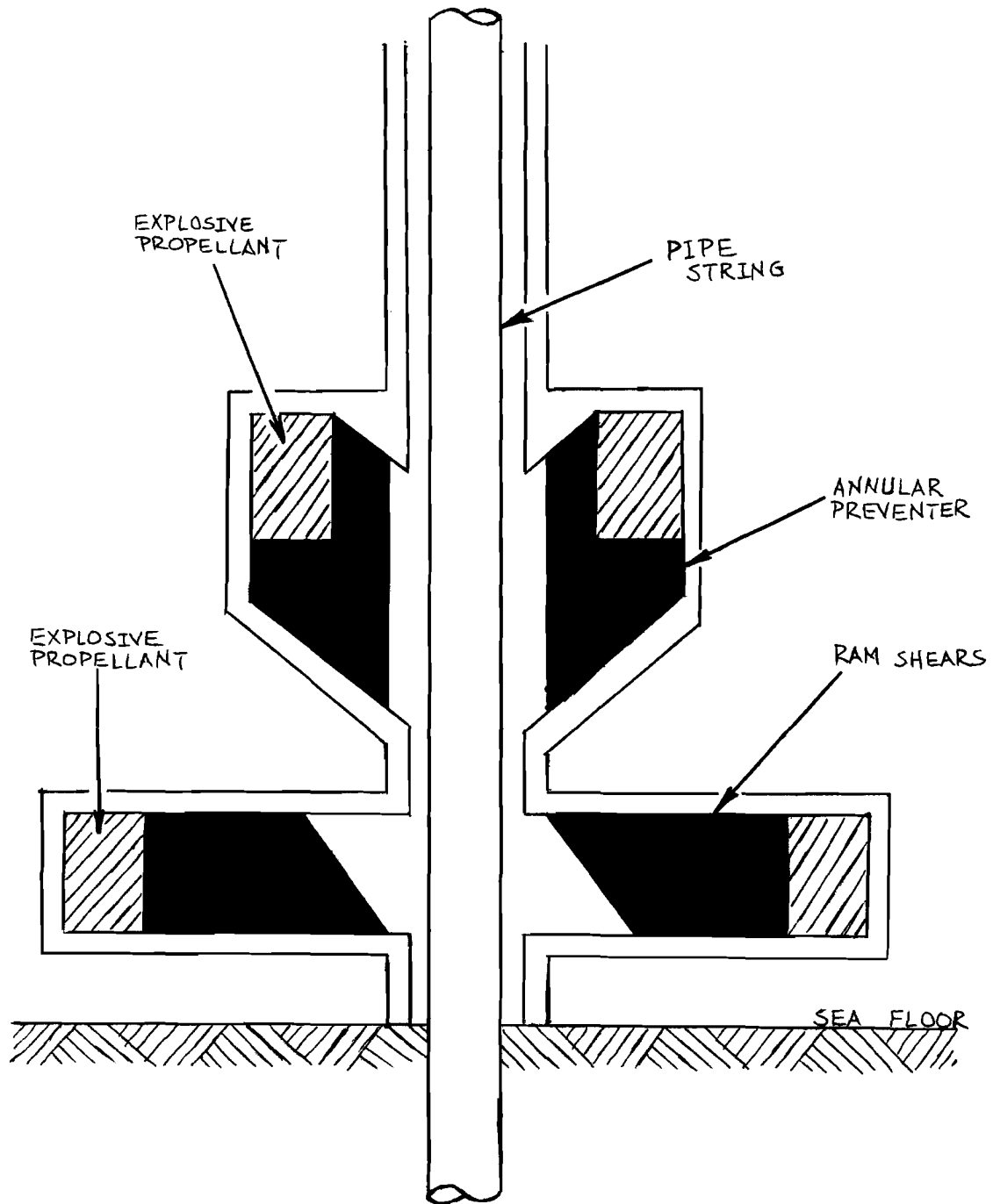
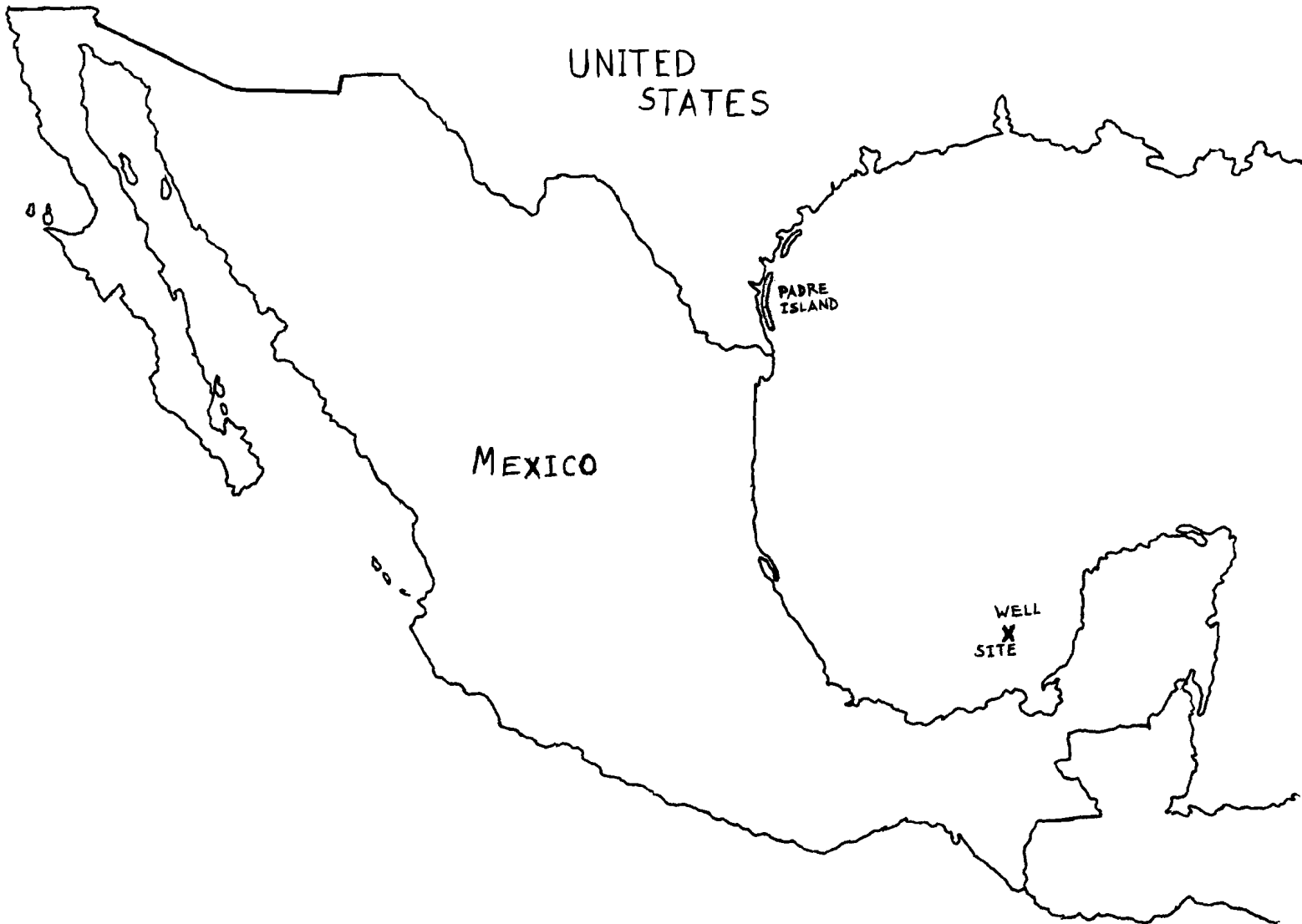


Figure 5: IXTOC I Well Site



geologists' assurances that no oil was expected in the formation that had been reached, Pemex, the final authority on operational matters, instead ordered the drill string withdrawn and the bit checked. On the night of June 2, the extraction of the string began. Pressure readings in the string were carefully monitored and seemed to indicate a dropping mud pressure and no building oil pressure in the well. At approximately three o'clock in the morning on June 3, the last stand (90 feet) of drill piping was being removed on the platform, placing the oversized drill collar in the blowout preventer stack on the sea floor. An unexpected surge of pressure from the well cross-threaded the piping being removed and jammed the disconnecting wrenches in place. A second, stronger surge blew mud followed by oil out the top of the string at the crown block and through the cross-threaded joint. With the wrenches jammed, the string could not be dropped back into the hole to clear the blowout preventer stack of the drill collar and the ram shears could not cut through the oversized collar when fired. At 0315, the escaping oil and gas caught fire and by 0330 the platform was abandoned as out of control.

Two supply vessels stood by for eight hours pumping water onto the burning rig, but the flames enveloping Sedco 135 made attempts to extinguish the fire futile. The derrick and much of the equipment stored on the platform collapsed onto the blowout preventer at mid-morning, but the anchors held the floating caissons fast. At noon,

the anchor chains were ordered cut, a process that took 24 hours. The platform was then towed 30 miles northwest of the well site and boarded by 11 marine surveyors. After a week of inspections, Sedco 135 was declared a total loss, towed further into the Gulf of Mexico, and scuttled.

### The Spill

The initial rate of flow from the unattended well was estimated by most creditable sources as 30,000 barrels/day (1,260,000 gallons/day) for the first two months of the spill<sup>2</sup>. Red Adair's attempts to clear the blowout preventer shears and reclose them reduced the flow for only a few hours, as the collapse of the platform had knocked over the Blowout preventer column. The flow rate was not significantly reduced until mid-August, when Pemex pumped thousands of steel and lead balls into the well, bringing the rate to 10,000 barrels/day.<sup>3</sup> During this month, the U.S. Coast Guard lent its support at Pemex's request and realized a maximum flow of 5,000 barrels/day through several weeks. In mid-September, the Coast Guard withdrew when Pemex installed an inverted "sombbrero" collector over the well.<sup>4</sup> After the collector, as illustrated in Figure 6, was in place, an engineering consultant from the Massachusetts Institute of Technology, Mr. Jerome Milgram, visited the well and estimated the device to be 90% effective in collecting natural gas, but only 10% effective in controlling the escape of crude oil. He also placed the

leakage rate at that time as high as 50,000 barrels/day.<sup>5</sup> By the end of February, 1980, two relief wells had been completed and Mexican authorities claimed the leakage rate to be less than 2,000 barrels/day,<sup>6</sup> and on March 5, 1980, the New York Times reported the flow rate as negligible and capping operations nearing completion.<sup>7</sup>

## II. On The Beach

### The Slicks<sup>8</sup>

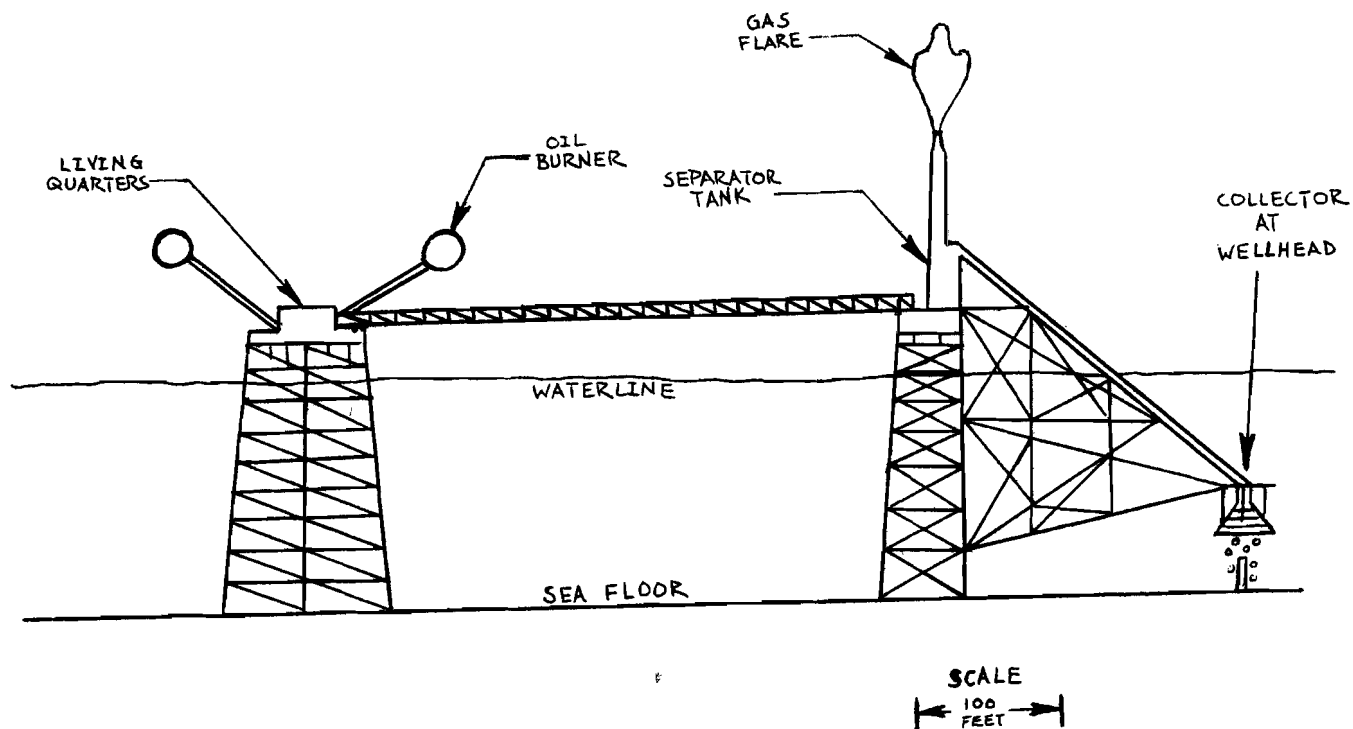
Though light lines of tar balls appeared on Texas beaches on August 6, 1979, they weathered away quickly. On August 13, however, the oil coverage began building (see Figures 7-9). There was light oiling as far north as Aransas Pass by August 17. The first heavy oiling occurred on South Padre Island on August 24. By August 26, U.S. Coast Guard personnel had placed 11 oil-absorbant booms across Brazos-Santiago Pass, six booms across Mansfield Pass, five booms across Aransas Pass, and three across Cedar Bayou. The heaviest impacts were felt between August 29 and September 1, when the levels of oil on Texas beaches reached 3,900 metric tons. No new oil was observed arriving on the beaches after September 1 and the pollution already present began to weather. By September 14, coverage was uniformly light and a tropical depression that hit during the next week reduced it further. Mousse patches found along most of North and South Padre Islands' beaches during October were broken up or buried by clean-up crews. The oil-absorbant booms prevented any serious contamination of the Laguna Madre, though minor impacts were observed at some sites.

### Wildlife Damage

Due to the relatively short period of heavy oiling, the protection of the Laguna Madre, and the natural resilience of the resources of the area, damage to South Texas' marine wildlife from IXTOC I was lighter than most had expected. In its 1981 summary of biological studies, the National Oceanic and Atmospheric Administration (NOAA)

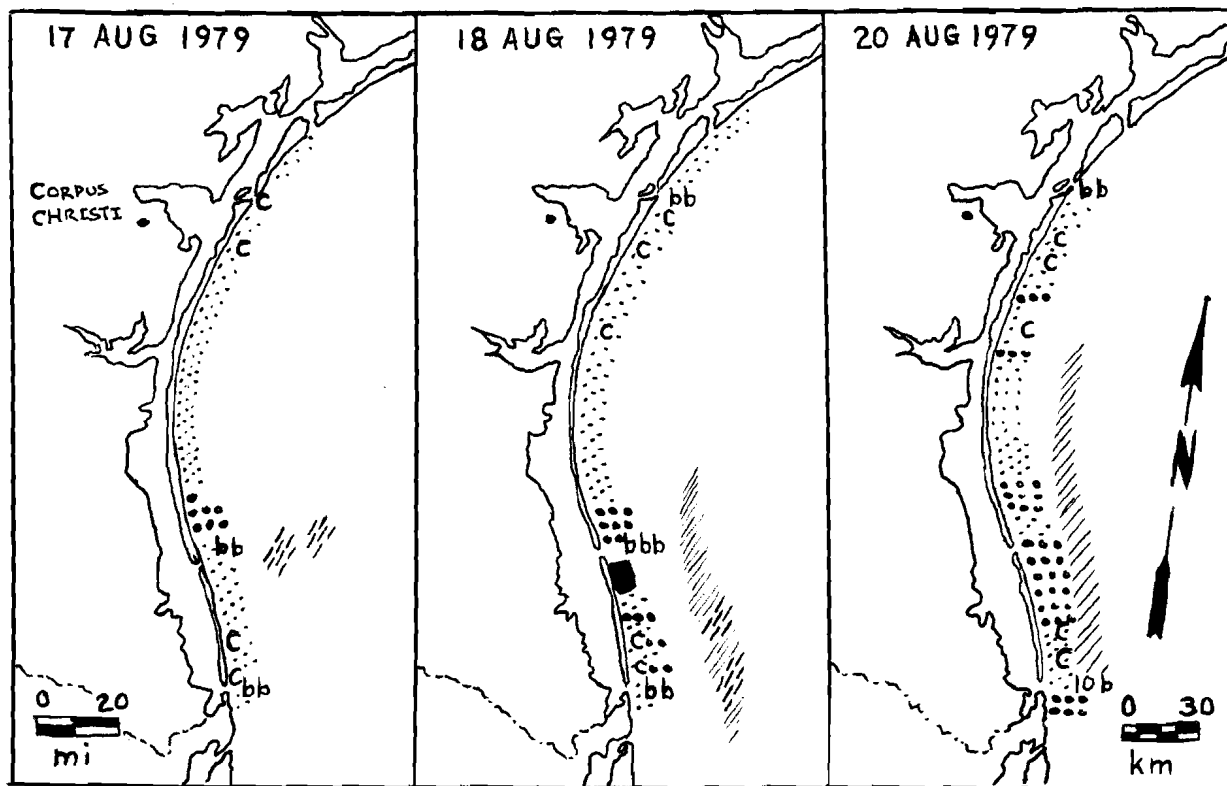


Figure 6: Steel Sombrero System



From U.S. Congress, Senate, Committee on Commerce, Science, and Transportation and Committee on Energy and Natural Resources, Campeche Oil Spill. Hearings before joint committee. 96th Cong., 1st Sess., ser. 96-66, 5 December 1979, p.93

Figure 7: Oiling of south Texas beaches, 17-20 August 1979



SHORELINE OIL

OFFSHORE OIL

VERY LIGHT

MODERATE

SHEEN

LIGHT

HEAVY

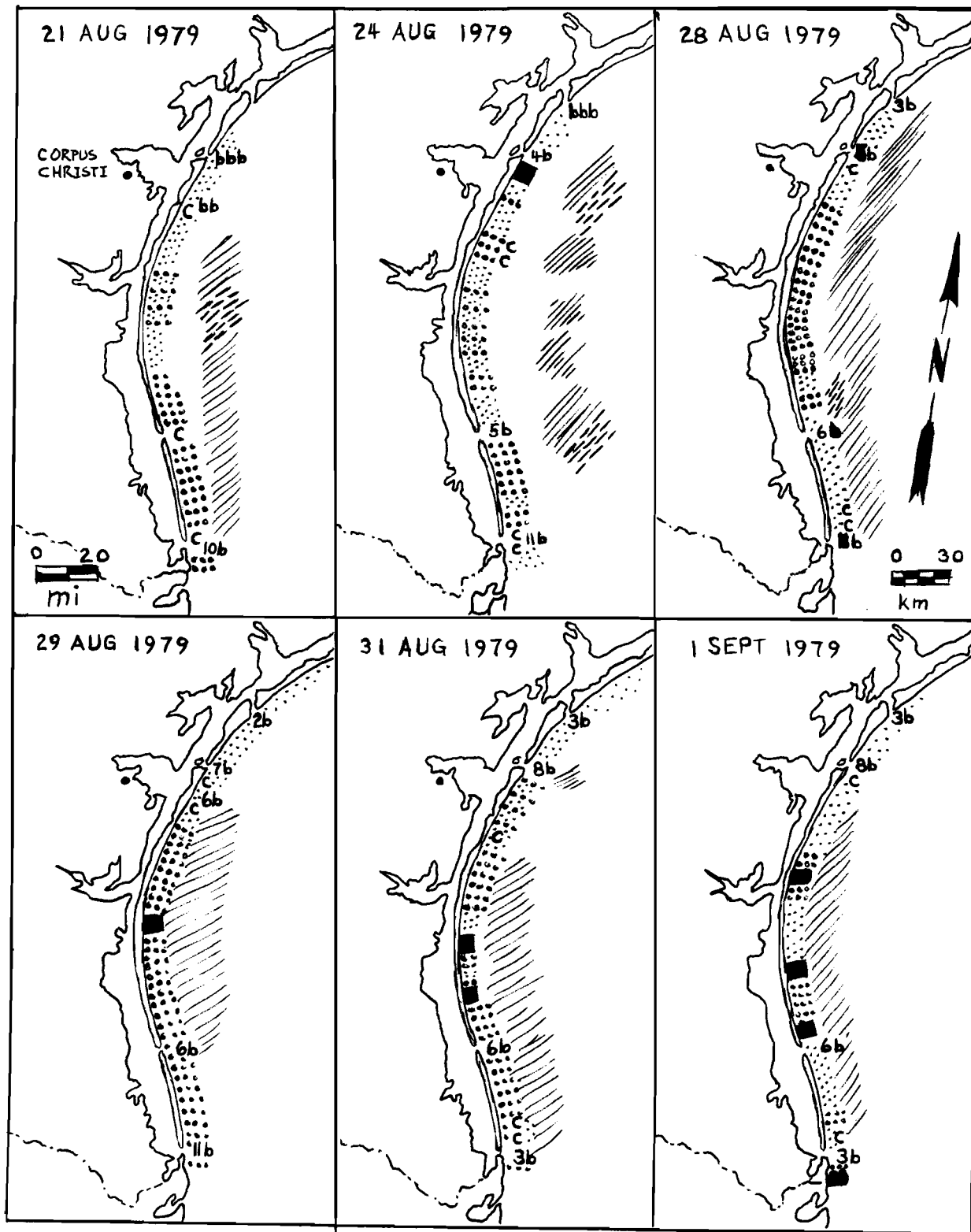
MOUSSE

b-BOOM

c-CLEANUP OPERATIONS

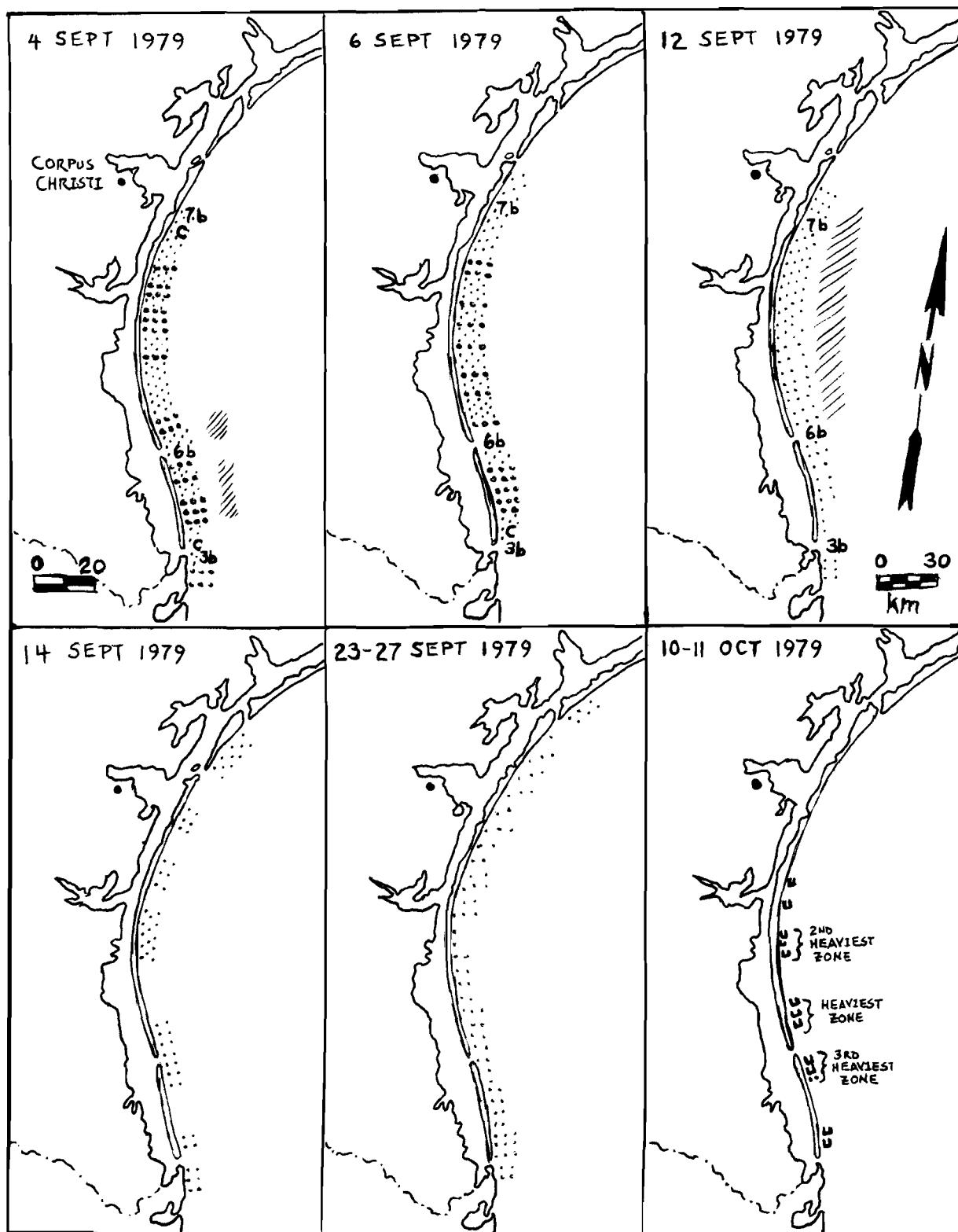
From Craig H. Hooper, ed., The IXTOC I Oil Spill: The Federal Scientific Response, NOAA Special Report (Washington D.C.: U.S. Government Printing Office, December 1981) p.42

Figure 8: Oiling of south Texas beaches, 21 Aug-1 Sept 1979



From Hooper, pp.43-44

Figure 9: Oiling of south Texas beaches, 4 Sept-11 Oct 1979



U-MOUSSE PATCHES

From Hooper, pp.45-46

listed the results of survey after survey as minor or insignificant. In the inlets and lagoons, the only significant oil impact observed was the oiling of a marsh for 10 days, which "...did not immediately inhibit photosynthesis or respiration of representative nearshore plankton samples and seagrasses."<sup>9</sup> On the sand beaches, NOAA found that the migratory birds instinctively avoided the more heavily oiled beaches, and "Ground observations of wading and shorebirds indicated that the oiled birds never exceeded 10%, peaking during periods of heaviest oiling."<sup>10</sup> Though populations of crabs and other beach infauna were significantly reduced along the intertidal zones, it was pointed out that "It was difficult to distinguish the effects of the oil spill from natural factors, especially storms and natural population variations."<sup>11</sup> Furthermore, "results of acute toxicity tests, conducted on subtidal amphipods and zooplankton, suggested that IXTOC I oil was not toxic to these species."<sup>12</sup> Toxicity tests on redfish, sea trout, and brown shrimp, the major fisheries species in the area, indicated no acute toxicity to adults, but high mortality and deformity rates in juvenile and larval populations.<sup>13</sup> In the actual fisheries, however, Food and Drug Administration (FDA) and National Marine Fisheries Service (NMFS) organoleptic tests did not find any seafood unfit for the market in representative samples, both oiled and clean.<sup>14</sup> Offshore populations renewed themselves quickly. Marine biologist Henry Hildebrand, testifying before Congress, said that,

"These organisms (offshore species) have tremendous reproductive capacity. Nearly every one we have on this coast does, because we have a very severe environment in this part of Texas."<sup>15</sup>

Concern with long term subtoxic effects was expressed in all of the studies reported and expert testimony before Congress, but most would by now agree with Linda Garmon's sources in the October 25, 1980 Science News,

...the overall environmental impact of IXTOC I will take years to evaluate. Still, some researchers already say the Gulf of Mexico seems back to normal. 'If you go to the beaches of South Padre Island today' said ACS Oil Spill Symposium participant Edward B. Overton, 'you'll find good swimming and good fishing.' Although it looks like 'the end of the world' on the beaches during an oil spill, 'the environment springs back.'<sup>16</sup>

#### Economic Damages

The economic damages to South Texas from the spill are difficult to quantify. As in any such disaster, the effects of the oil were not confined to the sea. Governmental costs were assessed by totalling monies spent to protect the Laguna Madre, clean the beaches, study the spill, and assist the local maritime industries, but the costs to the private sector were hidden in business losses.

The fishing industry is very important to South Texas, with commercial fishermen having landed \$125 million worth of catches in the region in 1978. The estimated value of the catch taken in bays and estuaries within the spill region in 1978 was \$4.5 million.<sup>17</sup> NMS and FDA programs worked through the fall of 1979 and the spring of

1980 to keep fishermen advised of the oil's whereabouts and to bolster consumer confidence in the Gulf's seafood,<sup>18</sup> but the small losses in catch levels and wholesale prices came at the expense of relocation and aggravation for many fishermen.

The deepest economic impact was felt by the area's tourist industry. Expenditures for tourist-related activities on Texas' coast were placed at \$445 million in 1972,<sup>19</sup> and the industry had certainly grown since. Though South Padre Island was heavily oiled for only a few weeks, the region's resort owners, charter boat operators, and Chambers of Commerce fought tremendous public relations battles. The media coverage of the spill simply did not create an image conducive to beach vacations during the summer of 1979. As the New York Times reported on August 11 of that year,

At South Padre Island itself, civic leaders have been angered by what they say are misleading reports of the situation. They especially criticize the television reports that, they say, make it look as if the beaches here are the heavily polluted Mexican beaches. They say that hurt more than the oil.<sup>20</sup>

Although Representative Kika de la Garza quoted a partial list of constituents' losses in his testimony before a subcommittee of the House Public Works and Transportation Committee on September 26, 1979,<sup>21</sup> the best indicator available is probably the legal claims made by various private concerns for some \$350 million in damages. Coupled with suits from the governments of the United States and the State of Texas, these claims boosted the costs of the spill to South Texas, as claimed in court, to nearly \$400 million.

### III. Before The Courts

#### Domestic Legislation

The history of federal pollution liability and compensation legislation in the United States shows an interesting progression. See Table 1. In 1851, when the first law broaching the subject was passed, little concern was felt for pollution. The encouragement of seagoing commerce was the major concern of Congress and, as such, the Limitation of Liability Statutes<sup>22</sup> stipulated that no vessel owner would be liable for any amount greater than the value of his vessel. By 1924, some interest in the preservation of our harbors and waterways had surfaced, and the discharge of oil, intentional or otherwise, was made illegal within the territorial waters of the United States under the Oil Pollution Act<sup>23</sup> of that year. The only liability assumed by a violator of that law, however, was a fine \$500 to \$2500. This prohibition was extended to 50 nautical miles from our coasts by the 1961 Oil Pollution Act<sup>24</sup>, but the concept of oil pollution prevention by simple prohibition lasted nearly 50 years. The first provisions dealing with tort liabilities in marine pollution appeared in the 1970 Water Quality Improvement Act<sup>25</sup>, indicating a change in federal policy. This law established the maximum liability of a tanker owner at \$100 per ton or \$14 million and placed the liability limit for offshore platforms at \$8 million. Along with amendments to the existing Federal Water Pollution Control Act<sup>26</sup>, the Water Quality Improvement Act (WQIA) established a liability on the part of the tanker owner and the offshore driller for damage done to



Table 1: Legislation Concerning Liability  
and Compensation for Oil Pollution

Year	Act	Liability		Compensation	
		Ship	Offshore Platform	Tax Levied	Fund Limit
1851	Limitation of Liability Act	Vessel Value	----	----	----
1924	Oil Pollution Act	\$500 to \$2500	----	----	----
1948	Water Pollution Control Act	----	----	----	----
1961	Oil Pollution Act	\$500 to \$2500	----	----	----
1966	Oil Pollution Act	\$500 to \$2500	----	----	----
1970	Water Quality Improvement Act	\$100/ton to \$14m	\$8m	----	\$35m
1972	Federal Water Pollution Control Act Amendments	\$100/ton to \$14m	\$8m	----	\$35m
1973	Oil Pollution Act Amendments	\$500 to \$2500	----	----	----
1973	Trans-Alaska Pipeline Authorization Act	\$14m	\$100m	5¢/bbl	\$100m
1974	Deepwater Port Act	\$150/ton to \$20m	----	2¢/bbl	\$100m
1977	Clean Water Act	\$150/ton to \$250k	----	----	\$35m
1978	Outer Continental Shelf Lands Act Amendments	\$300/ton	\$35m	3¢/bbl	\$200m
1981	H.R. 85 (Proposed)	\$300/ton	\$50m	1.3¢/bbl	\$375m

Condensed from: Neal Shapiro, "Oil Pollution Liability and Compensation:", Marine Technology Society Journal 16 (January 1982) 25

other marine activities or the environment. Monies were set aside for compensation of damages exceeding the limits established under the laws, with the funds, not to exceed \$35 million, appropriated annually from the federal budget. Yet another new concept found voice in three further laws: the 1973 Trans-Alaska Pipeline Act<sup>27</sup>, the 1974 Deepwater Port Act<sup>28</sup>, and the 1978 Outer Continental Shelf Lands Act Amendments<sup>29</sup>. The framers of these laws instituted taxes on the petroleum products transported through their subject domains to fill the coffers of the compensation funds. Though the taxes are only a small percentage of the value of the oil, the maximum levy being \$.05 per barrel, compensation limits rose to \$200 million under this scheme. A large fund also allows quicker compensation for damages, as the government can be seen as an insurer, in effect, paying claims from the fund and itself prosecuting for damages. Although the concept of user fees has been highly praised by all concerned, no comprehensive fund has been established to this day. Though an accident in domestic drilling would have afforded some compensation under the law, the lack of such a comprehensive law left South Texas' damaged parties to their own devices in court.

In summary, domestic legislation does not provide sufficient relief from the damage caused by a blowout on the high seas. The Limitation of Liability Act remains in effect, arguably vitiating the provisions of more recent statutes such as the FWPCA and the OCSLA. Although the latter acts are intended to compensate victims of oil spills, they overlap, and their jurisdiction is restricted to two hundred miles offshore...hence, none of the parties can rely on existing legislation for relief<sup>30</sup>.

## International Law

The body of international law agreed upon between the United States and Mexico unfortunately provides little recourse to claimants of damages from transnational pollution. Gerhard von Glahn, in his book, Law Among Nations, takes the direction of the Statute of the International Court of Justice in defining the sources of international law, stating that,

Article 38 of the Statute directs the International Court of Justice to apply: (1) international conventions, whether general or particular, establishing rules expressly recognized by the contesting states; (2) international custom, as evidence of a general practice accepted as law; (3) the general principles of law recognized by civilized nations; and (4) subject to the provisions of Article 59, judicial decisions and the teachings of the most highly qualified publicists (writers) of various nations as subsidiary means for determination of rules of law.<sup>31</sup>

The International Maritime Organization of the United Nations maintains two international conventions dealing with vessel source pollution liability: the 1969 International Convention on Civil Liability for Oil Pollution Damage<sup>32</sup> and the 1971 Convention on the Establishment of an International Fund for Compensation of Oil Pollution Damage<sup>33</sup>, which provide liberal compensation for such damages as were suffered in Texas. The IXTOC I platform, however, did not fall under their definitions. "Ship" as subject to these conventions,

...means any sea-going vessel of any type whatsoever, and any seaboarne craft carrying oil in bulk, but does not include any warship or other ship owned or operated by a State and used for the time being only on government non-commercial service.<sup>34</sup>

The issue of pollution liability is contemporary and formative enough that few questions were raised of customary international law to cover U.S. claims.

The concept of sic utero tuo ("one must so use his own as not to do injury to another") as elaborated in the 1972 Stockholm Declaration of the United Nations Conference on the Human Environment<sup>35</sup> and tort liability provisions in the Federal Civil Code of the Republic of Mexico<sup>36</sup> were cited as applicable principles of law by claimants, but no specific compensation requirements appear in either reference, allowing Mexico an out.

As for judicial decisions, many writers cited the 1905 Trail Smelter Arbitration<sup>37</sup> between the United States and Canada, wherein Canada was held liable for damages to U.S. interests as a result of air pollution from a privately owned and operated smelter located in British Columbia, as a precedent<sup>38</sup>. The analogy to the IXTOC claims was, in fact, a very good one but Mexico responded by reiterating previous claims against the United States for salt-spoiled farmlands on the southern shores of the Rio Grande.

It is important to note that, though a case may be made for Mexican liability on the strength of general principles of law and a previous International Court of Justice decision, the lack of specific treaty law and the absence of a specifically agreed upon compromise between the United States and Mexico made adjudication by the International Court of Justice impossible. Few wondered that Mexico did

not agree to such. As Karl E. Meyer pointed out in his October, 1979 editorial "What Mexico Remembers,"

...the Mexican president says there will be no compensation. Did the United States, he wonders, compensate Mexico for the ruination of the Mexicali Valley by the Colorado River's saline water? It did not.

A less recent episode, however, yields deeper explanation for Mexico's resentment. American and European oil companies once made huge compensation claims against Mexico. The Mexican government was eventually forced to pay about \$130 million for assets it had seized-but only after enduring a punishing boycott by the oil companies<sup>39</sup>.

The settlement to which Mr. Meyer refers was paid in 1941, but its memory returned with a vengeance in 1979.

#### Litigation

The attempts to recover losses suffered as a result of IXTOC I's blowout were initiated in the United States District Court for the Southern District of Texas, where the first suits were filed during September and October of 1979. On September 13, a class action suit was filed by a group of fishermen seeking \$155 million in damages.<sup>40</sup> This suit was joined by other private commercial interests through the next year and by early 1983 the claims had risen to \$350 million.<sup>41</sup> The State of Texas filed suit on October 19 to recover \$10 million in clean-up costs and public expenditures.<sup>42</sup> The United States government sued on October 24, setting its claim at \$6 million.<sup>43</sup> The respondents named in all three suits were Sedco, Permargo, and Pemex.

The obvious and overriding obstacle to U.S. claims was jurisdiction. The accident occurred in Mexican waters; the drilling

was financed entirely by a Mexican corporation (and a nationalized one, at that); and the purpose of the project was exploration, not production. Sedco 135 was owned by a Texas corporation, but Sedco, Inc. quickly moved to limit its liability under the 1851 Limitation of Liability Act. The motion by plaintiffs seeking jurisdiction over Permargo and Pemex in District Court was based on Texas' long-arm statute<sup>44</sup>, which provides in part that,

Any foreign corporation, association, joint stock company... that engages in business in this State...and does not maintain a regular place of business in this State or a designated agent upon whom service of process may be made upon causes of action arising out of such business done in the State, the act or acts of engaging in such business...shall be deemed equivalent to an appointment...of the Secretary of State of Texas as agent upon whom service of process may be made in any action, suit or proceedings arising out of such business done in this State...<sup>45</sup>

Pemex immediately moved for exemption, claiming itself an agent of the Mexican government and thereby immune from tort liability under the Foreign Sovereign Immunities Act of 1976<sup>46</sup>. Permargo also attempted to deny the jurisdiction of the U.S. courts, claiming that its business ties with Texas were insufficient to satisfy the long-arm statute.

In a preliminary ruling on March 30, 1982, District Court Judge O'Connor delineated liabilities in the face of these motions and virtually dashed the plaintiffs' hopes of recovering their full losses. Pemex's plea of sovereign immunity was upheld over attempted invocation of exceptions listed in the Foreign Sovereign Immunities Act, as Judge O'Connor held that,

Pemex, in this case, was executing a national plan formulated at the highest levels of the Mexican government by exploring for Mexico's natural resources. Any act performed by a subordinate of Pemex in furtherance of this exploration plan was still discretionary in nature and immune from suit under the FSIA. To deny immunity to a foreign state for the implementation of its domestic economic policies would be to completely abrogate the doctrine of foreign sovereign immunity by allowing an exception to swallow the grant of immunity...<sup>47</sup>

In the matter of Permargo's liability, Judge O'Connor denied the motion for dismissal due to lack of jurisdiction, stating that,

Here, the Court has determined that Permargo has availed itself of the benefits and laws of this forum and that Court may constitutionally exercise personal jurisdiction with respect to the private and public plaintiffs' direct claims against Permargo. Sedco, like the direct plaintiffs, has served Permargo pursuant to (the long-arm statute). Since Sedco seeks to recover over against Permargo for claims arising from the alleged maritime tort made the basis of the direct plaintiffs' claims, this Court finds that it is amenable to service of process under the Texas long-arm statute for the reasons previously discussed.<sup>48</sup>

As for Sedco's liability, Judge O'Connor upheld the motion seeking exoneration under the Limitation of Liability Act. To plaintiffs' complaints that the law was outmoded, Judge O'Connor replied that, "Whether the Act retains vitality within the sphere in which it has traditionally applied is a matter for Congress, not the courts, to decide."<sup>49</sup> These rulings effectively denied the plaintiffs access to the "deep pocket" defendants since Permargo's assets simply would not cover any reasonable settlement.

The case stalled at this juncture for a year. In February of 1983, Judge O'Connor held a closed meeting with the litigants and Sedco offered to settle out of court with the plaintiffs shortly thereafter.

The federal government and the private interests accepted this offer and in March 1983, Sedco made payments of \$2 million and \$2.14 million respectively to the U.S. government and the businessmen who had joined in the suit.<sup>50</sup> As agreed in the settlement, these parties immediately dropped their suits against Permargo and Pemex. Sedco, however, retained its actions against both Mexican companies. The State of Texas, not having accepted the settlement with Sedco, also remains in litigation at this writing.

#### Effects and Proposals

In view of the settlements made in this case to date, the tremendous disparity between the damages suffered by private industry and the monies received by them in compensation must concern any maritime businessman. The U.S. government has concerned itself, also, and several proposals have emerged in the aftermath of the spill.

On the domestic front, bills have been introduced in both Houses of Congress since 1979 to provide a "superfund" for the compensation of victims of oil pollution. The money would be drawn from a tax on oil imports and refinery products and the definitions would be expanded to include pollution from incidents on the high seas or in foreign waters. In effect, the federal government would be providing insurance against future spill damages in a single compensation fund. H.R. 85, A Bill to Provide a Comprehensive of System Liability and Compensation for Oil Spill Damage and Removal Costs, passed the House



of Representatives in late 1981, but was not acted upon by the Senate before adjournment. Though reintroduced with each succeeding Congress, the proposal has yet to be passed into law. The major obstacles to passage of such a law are the preemptive provisions of the federal act over state-administered funds, the relation of such domestic legislation to international treaties, and the administrative details of liability limits and ancillary uses of the fund. These concerns, though valid, pale before the need to close the loopholes in our laws and protect our maritime businessmen. As Congressman E. (Kika) de la Garza of South Texas stated before a Congressional subcommittee hearing,

Simply stated, the measure is long overdue. The tragic effects of the Padre Island oil spill would have been sharply diminished had the measure been acted on affirmatively...the effects of this spill illustrate poignantly the helplessness of the small businessman to cope financially with the forces of matters over which he has no control.<sup>51</sup>

In the international arena, regulation by law-making treaty is winning support within the community of nations. In an interesting proposal, William N. Hancock and Robert M. Stone suggest in a Hastings International and Comparative Law Review article that,

The problem of oil well blowouts, however, could be addressed at a more 'local' level. Oil rig platforms generally operate in a narrow band along a nation's continental shelf or in relatively shallow seas. Therefore, an agreement between only two or three nations may prove effective in providing a scheme of liability for offshore blowouts. For example, an agreement between the United States and Mexico, or among the United Kingdom, France, and Belgium, may be on a scale sufficient to provide true protection to the contracting states.<sup>52</sup>

Hancock and Stone point to an existing agreement among 13 oil companies operating in the North Sea, but an accord on the subject with Mexico seems a hopeful ideal at this point. With the animosity to U.S. claims felt south of the border, the only treaty that could be negotiated in IXTOC's aftermath is the Agreement of Cooperation between the United States of America and the United Mexican States regarding Pollution of the Marine Environment by Discharge of Hydrocarbons and Other Hazardous Substances of June 24, 1980.<sup>53</sup> The Harvard International Law Review noted that "The agreement...fails to establish procedures or mechanisms for determining liability and compensation for marine pollution damage, leaving most victims without adequate remedy."<sup>54</sup> Even at such a regional level, much remains to be negotiated.

## CONCLUSIONS

There is a range of conclusions that may be drawn from the aftermath of IXTOC I's blowout, from the deepened conviction within the oil industry that offshore drilling will not permanently degrade our beaches to the dread realization on the part of many resort operators and fishermen that the economic nightmares of transnational pollution may next be theirs. By any standard, however, the importance of the conclusion drawn is found in the changes made as a result. Whether by using the scientific data on spill effects to justify further offshore operations or by working to plug the legal loopholes that cost South Texas so much, the lessons of IXTOC I must be used to further our management of the nation's marine resources.

## ENDNOTES

<sup>1</sup>Except as noted otherwise, all facts and figures from: Richard E. Ford, USCG, Investigation on "Semi-submersible drill barge SEDCO 135, O.N. 298297; IXTOC I well blowout with subsequent fire in the Bay of Campeche, Mexico, in position 19-24N, 92-12W, on 3 June 1979 without personnel injuries, but with major oil pollution," U.S. Coast Guard serial 16732/3104/REF of April 23, 1981.

<sup>2</sup>"Well Blows Out Off Yucatan; Oil Find Hinted," New York Times, 9 June 1979, p.1; and U.S. Congress, Senate, Committee on Commerce, Science, and Transportation and Committee on Energy and Natural Resources, Campeche Oil Spill. Hearings before joint committee. 96th Cong., 1st Sess., ser. 96-66, 5 December 1979, p. 13.

<sup>3</sup>"Mexico's Gains on Oil Well May Save Beaches of Texas," New York Times, 28 February 1980, p. 18.

<sup>4</sup>U.S. Congress, Campeche Oil Spill, p. 16.

<sup>5</sup>Ibid., pp. 95, 99.

<sup>6</sup>"Mexico's Gains," p. 18.

<sup>7</sup>"Mexico Caps Runaway Oil Well; Loss is Put at 3.1 Million Barrels," New York Times, 25 March 1980, p. A4.

<sup>8</sup>Facts and figures from Craig H. Hooper, ed., The IXTOC I Oil Spill: The Federal Scientific Response, NOAA Special Report (Washington, D.C.: U.S. Government Printing Office, December 1981) pp. 41-54.

<sup>9</sup>Ibid., p. 166.

<sup>10</sup>Ibid., p. 167.

<sup>11</sup>Ibid., p. 169.

<sup>12</sup>Ibid.

<sup>13</sup>Ibid.

<sup>14</sup>Ibid., p. 114.

<sup>15</sup>U.S. Congress, House, Committee on Merchant Marine and Fisheries and subcommittee of Committee on Public Works and Transportation, Blowout of Mexican Oil Well IXTOC I. Hearings before joint committee. 96th Cong., 1st Sess., ser. 96-19, 8-9 September 1979, p. 235.

<sup>16</sup>Linda Garmon, "Autopsy of an Oil Spill, Science News 118 (25 October 1980) 269-270.

<sup>17</sup>Hooper, p. 100.

<sup>18</sup>Ibid., pp. 113-115.

<sup>19</sup>Ibid., p. 99

<sup>20</sup>"Texas Surviving Worst Oil Spill, but Experts Say Harm May Not Be Known for Years," New York Times, 11 August 1979, p. 6.

<sup>21</sup>U.S. Congress, House, Subcommittee of the Committee on Public Works and Transportation, H.R. 85: A Bill to Provide a Comprehensive System of Liability for Oil Spill Damage and Removal Costs. Hearing before the Subcommittee on Water Resources. 96th Cong., 1st Sess., ser. 96-26, 26 September 1979, pp. 397-400.

<sup>22</sup>46 USC § § 183-189 (1851).

<sup>23</sup>Act of 7 June 1924, Ch. 316, 43 Stat. 604.

<sup>24</sup>33 USC § § 1001-1015.

<sup>25</sup>84 Stat. 91-107.

<sup>26</sup>33 USC § § 1151 et. seq. (1970).

<sup>27</sup>43 USC § § 1651-1655.

<sup>28</sup>33 USC § § 1501-1524; 43 USC § 1333.

<sup>29</sup>43 USC § § 1801 et. seq. (1978).

<sup>30</sup>Hilde D. Preston, "Domestic and International Liability for the Bay of Campeche Oil Spill," International Trade Law Journal 6 (Fall/Winter 1980-1981) 67.

<sup>31</sup>Gerhard von Glahn, Law Among Nations: An Introduction to Public International Law, 4th ed. (New York: MacMillan Publishing Company, 1981) p. 16.

<sup>32</sup>"International Convention on Civil Liability for Oil Pollution Damage," American Journal of International Law 64 (April 1970) 481-490.

<sup>33</sup>"Convention on the Establishment of an International Fund for Compensation for Oil Pollution Damage," International Legal Materials 11 (March 1972) 284-302.

<sup>34</sup>"Civil Liability Convention," p. 454.

<sup>35</sup>"The U.N. Conference on the Human Environment held at Stockholm," Department of State Bulletin LXVII (24 July 1972) 105-118.

<sup>36</sup>Federal Civil Code of the Republic of Mexico, Art. 1910 and 1913; and Regulations for the Petroleum Operations, D.O. Ch. I, Art. 94, 358-29 and Art. 32, 358-61.

<sup>37</sup>"Trail Smelter Arbitration," American Journal of International Law 35 (1941) 684-736.

<sup>38</sup>Cited by Preston, pp. 70-71; and William N. Hancock and Robert M. Stone, "Liability for Transnational Pollution Caused by Offshore Oil Rig Blowouts," Hastings International and Comparative Law Review 5 (Spring 1980) 378-380.

<sup>39</sup>Karl E. Meyer, "What Mexico Remembers," New York Times, 4 October 1979, p. A 30.

<sup>40</sup>"Sedco, Mexico Firms Sued by Fishermen for Oil Spill Losses," Wall Street Journal, 14 September 1979, p. 18.

<sup>41</sup>"Sedco Settles Oil Spill Suit; Amount Represents Fraction of Sum Sought," Dallas Morning News, 24 March 1983, p. A 7.

<sup>42</sup>"Texas Sues Sedco, Inc. and Mexican Concern for Oil Spill Damages," Wall Street Journal, 19 October 1979, p. 34.

<sup>43</sup>"U.S. Seeks to Recover \$6 Million from Sedco for Oil Spill Cleanup," Wall Street Journal, 24 October 1979, p. 2.

<sup>44</sup>Texas Revised Civil Statute Art. 2031b (Vernon 1975 and supp. 1982).

<sup>45</sup>*Ibid.*, § 4.

<sup>46</sup>28 USC § § 1602 et. seq. (FSIA).

<sup>47</sup>543 Federal Supplement 561 (1982) p. 567.

<sup>48</sup>*Ibid.*, p. 570.

<sup>49</sup>Ibid., p. 572.

<sup>50</sup>"Sedco Agrees to Pay \$2 Million to Settle '79 Oil Spill Claims," Wall Street Journal, 3 March 1983, p. 3; and "Judge Finalizes Accord with Sedco in Oil Spill Suits," Oil Daily, 16 June 1983, p. 3.

<sup>51</sup>U.S. Congress, H.R. 85, p. 397.

<sup>52</sup>Hancock and Stone, p. 393.

<sup>53</sup>"Agreement of Cooperation between the United States of America and the United Mexican States Regarding Pollution of the Marine Environment by Discharge of Hydrocarbons and Other Hazardous Substances," International Legal Materials 20 (May 1980) 696-710.

<sup>54</sup>Barry C. Barnett, "Transnational Pollution: Agreement Regarding Marine Pollution Incidents," Harvard International Law Journal 23 (1982) 184.

SELECTED BIBLIOGRAPHY

- "Agreement of Cooperation between the United States of America and the United Mexican States Regarding Pollution of the Marine Environment by Discharge of Hydrocarbons and Other Hazardous Substances." International Legal Materials 20 (May 1980) 696-710.
- Barnett, Barry C. "Transnational Pollution: Agreement Regarding Marine Pollution Incidents," Harvard International Law Journal 23 (1982) 177-184.
- "Convention on the Establishment of an International Fund for Compensation for Oil Pollution Damage," International Legal Materials 11 (March 1972) 284-302.
- Ford, Richard E. USCG. Investigation on "Semi-submersible drill barge SEDCO 135, O.N. 298297; IXTOC I well blowout with subsequent fire in the Bay of Campeche, Mexico, in position 19-24N, 92-12W, on 3 June 1979 without personnel injuries, but with major oil pollution." U.S. Coast Guard serial 16732/3104/REF of April 23, 1981.
- Gorman, Linda "Autopsy of an Oil Spill," Science News 118 (25 October 1980) 267-270.
- Hancock, William N. and Stone, Robert M. "Liability for Transnational Pollution Caused by Offshore Oil Rig Blowouts." Hastings International and Comparative Law Review 5 (Spring 1980) 377-395.
- Helfrich, James C. "Problems in Pollution Response Liability Under Federal Law: FWPCA Section 311 and the Superfund." Journal of Maritime Law and Commerce 13 (July-October) 455-479.
- Hooper, Craig H. ed. The IXTOC I Oil Spill: The Federal Scientific Response, NOAA Special Report (Washington, D.C.: U.S. Government Printing Office, December 1981).
- "International Convention on Civil Liability for Oil Pollution Damage." American Journal of International Law 64 (April 1970) 481-490.
- Leventhal, F. Daniel. "The Bay of Campeche Oil Spill: Obtaining Jurisdiction Over Petroleos Mexicanos Under the Foreign Immunities Act of 1976." Ecology Law Quarterly 9 (Winter 1980-1981) 341-377.
- Preston, Hilde D. "Domestic and International Liability for the Bay of Campeche Oil Spill," International Trade Law Journal 6 (Fall/Winter 1980-1981) 67.



- Shapiro, Neal. "Oil Pollution Liability and Compensation." Marine Technology Society Journal 16 (January 1982) 23-28.
- "Trail Smelter Arbitration," American Journal of International Law 35 (1941) 684-736.
- "The U.N. Conference on the Human Environment held at Stockholm," Department of State Bulletin LXVII (24 July 1972): 105-118.
- U.S. Congress, House, Committee on Merchant Marine and Fisheries and subcommittee of Committee on Public Works and Transportation, Blowout of Mexican Oil Well IXTOC I. Hearings before joint committee. 96th Cong., 1st Sess., ser. 96-19, 8-9 September 1979.
- U.S. Congress, House, Subcommittee of the Committee on Public Works and Transportation, H.R. 85: A Bill to Provide a Comprehensive System of Liability for Oil Spill Damage and Removal Costs. Hearing before the Subcommittee on Water Resources. 96th Cong., 1st Sess., ser. 96-26, 26 September 1979.
- U.S. Congress, Senate, Committee on Commerce, Science, and Transportation and Committee on Energy and Natural Resources, Campeche Oil Spill. Hearings before joint committee. 96th Cong., 1st Sess., ser. 96-66, 5 December 1979.
- Glahn, Gerhard von Law Among Nations: An Introduction to Public International Law, 4th ed. (New York: MacMillan Publishing Company, 1981).
- West, James M. "The IXTOC I Oil Spill Litigation: Jurisdictional Disputes at the Threshold of Transnational Pollution Responsibility." Texas International Law Journal 16 (Summer 1981) 475-532.