

---

# The value of simulation and immersive virtual reality environments to design decision making in new product development.

**Dr A J Robotham, Dr F Shao**

Virtual Engineering Centre / University of Liverpool  
Daresbury Science and Innovation Campus, Warrington, WA4 4AD, UK  
A.J.Robotham@liverpool.ac.uk, shaofei7@liverpool.ac.uk  
web-page: <http://www.virtualengineeringcentre.com/>

## ABSTRACT

In response to the need to develop more sophisticated, higher quality products product developers are more and more expecting engineering simulations to provide them with the data, information, and knowledge required to make design decisions. Engineering simulations provide insight into the behaviour of virtual product designs and have the capacity to be executed many thousands of times to provide a comprehensive coverage of the solution space being explored. However, engineering simulations are only representative of a reduced set of product properties and are bound by the constraints imposed by the fidelity of the underlying physics of the simulation tools being used. .

In this paper, we will briefly explore a number of different types of engineering simulation that the Virtual Engineering Centre has been involved in creating and consider the value that the data, information and knowledge that each creates to the decision making process.

We will also explore how different visualisation methods being used at the Virtual Engineering Centre support decision making by individuals and groups of people in a design review context. Specifically, we will discuss the use of immersive virtual reality in reviewing simulation results and highlight the limitations of using this technology in group decision making using case studies taken from our work with different companies.

We will conclude that whilst virtual technologies provide opportunities to generate data and information early in the product development process, the ever increasing demands for accuracy and fidelity in representation in mature product sectors outstrips the capability of the technology to fully support decision making in a complete virtual world.

**Keywords:** Simulation, Virtual Reality, Immersion, Decision Making

## INTRODUCTION

Product development is an ongoing cycle of new product development projects that seeks to maintain, if not enhance, the competitive advantage of a company. Successful companies, e.g. market leaders, recognise that the competitive advantage they have over their rivals is due to superior product quality, value for money, service and closeness to their customer.

In order to achieve competitive advantage in product quality, a cornerstone of new product development should be life cycle oriented design. Whilst a full argumentation for this approach will not be detailed here, the principles are outlined below. Life cycle oriented design is a foundation of design for quality, which focuses upon creating high quality products with appropriate quality properties that satisfy the needs of everyone who has a stake in the product during its life cycle.

---

## Product quality and life cycle oriented design

During the “cradle to grave” life of a product, many different people will interact with the product, each in a different context and with a purpose different to the others. These people are known as stakeholders and each will have a set of needs to be satisfied. The work of Mørup in “Design for Quality” [1], fully describes the relationship between product quality, the product life cycle, and stakeholders.

Product quality starts in the design process with the design team. In life cycle oriented design, the design team must anticipate all the life cycle demands made of the product and create design solutions that will have the appropriate properties to fulfil the quality expectations of all the stakeholders. The failure to consider or anticipate a likely mode of use, context of use, or type of user may result in the product being used in a manner that had not been considered and where failure could have considerable consequences on product quality and acceptance.

In order to create a model of the product life cycle, it is necessary to determine each of the discrete meetings, which will occur between the product and the stakeholders. Scenarios are a highly relevant means for describing what occurs in these meetings and, if organised in a sequence, can be used to map the product passing through all the phases of its life.

Understanding of the events which occur in each meeting enables the needs of the stakeholder to be identified, the functions of the product to be determined, and what properties the product should have to satisfy, and even delight, the customer. The level of abstraction used to describe a meeting will vary depending upon the design context. However, if a meeting is sub-divided into smaller, more discrete events, then a larger number of functions (or rather sub-functions) and properties will be identified.

With this detailed understanding of the product life cycle, functions, needs and properties, the design task is then to create a solution that best satisfies all of these requirements. During the design process, the performance of new ideas should be evaluated for all life phases, and successful solutions for one function synthesised with solutions for other functions. By continually comparing design results with life cycle needs, it is possible to maintain a check upon whether a design solution is emerging with the appropriate quality properties.

However, despite all the efforts that can be made during the product development process to validate the design solution, the true quality of the solution can only be verified when the product is realised and each stakeholder can interact with it. In summary: *The totality of product quality is achieved only when all life cycle phases have been thoughtfully considered, and all stakeholders delighted by their interaction with the product* [2].

## Scenarios

*“Scenarios are not formal; they are not scientific in any fancy sense. We know that they can be used because they already do play many roles in the system lifecycle. Perhaps the time has come to consider how a more integrative scenario perspective for system development can be constructed”* [3]

*“Multiple scenarios allow us to explore different visions of the future – “cover the field” as much as possible.”* [4]

Scenarios have become a popular vehicle in a problem area central to all design efforts:

---

the management of change. By offering a down-to-earth middle-level abstraction between models and reality, scenarios promote shared understanding of the current situation and joint creativity toward the future [5,6].

The main purpose of introducing scenarios in design is to stimulate thinking, e.g. scenarios are “*a creative tool that facilitates the leap from observation to invention*” [4]. This is also apparent in Carroll’s definition of the concept:

*“The defining property of a scenario is that it projects a concrete description of activity that the user engages in when performing a specific task, a description sufficiently detailed so that design implications can be inferred and reasoned about”* [3].

People use scenarios for a variety of different tasks and to accomplish a variety of specific goals, for example: in requirements analysis to embody the needs apparent in current work practice [7] in user-designer communication as a mutually understood means of illustrating important design issues or possible designs [8] in software design as a means to identify the central work domain objects that must be suitably included in the system; in documentation and training as a means to bridge the gap between the system as an artefact and the tasks users want to accomplish using it; and in evaluation as a means of defining the tasks the system has to be evaluated against [9].

Scenarios take many forms with respect to form, contents, purpose, and life cycle issues. Some use narrative text to produce extensive descriptions of how the system interacts with its environment, and use these descriptions in a range of activities throughout the development process. Others use diagrammatic notations to produce dense descriptions of interactions among internal system components, and use these descriptions to ensure agreement among partial views at a few clearly defined points in the development process [6].

Scenarios are, however, not simply available for use, they have to be managed. The need for scenario management increases, as scenarios become increasingly pervasive artefacts used throughout the product life cycle. Scenario management involves: capturing/generating scenarios; structuring and co-ordination of scenarios; evolution and traceability; reviewing scenarios; and documenting scenarios.

## **Engineering simulations**

In response to the need to develop more sophisticated, higher quality products, product developers are more and more expecting engineering simulations to provide them with the data, information, and knowledge required to make design decisions. Engineering simulations provide insight into the behaviour of *virtual products* and systems and have the capacity to be executed many thousands of times to provide a comprehensive coverage of the solution space being explored.

Engineering simulations, in the context of the discussion here, are generally deterministic in nature, with well-defined behavioural properties of the engineering systems being studied; the solution space to be evaluated is pre-determined; and transient changes to the input parameters are usually specified at the start the simulation process. The objective of engineering simulations is to understand the dynamic behaviour of an engineering system over time and/or determine its steady state response. Engineering simulations are built on a foundation of physical science knowledge and models of behaviour; complex, multi-disciplinary solutions will be built from the integration of several discrete simulations, with the interaction of different physical phenomena coupled through iterative workflows.

The search for an optimised solution across the solution space further complicates the demands of simulation; its requires many thousands of simulations to be executed, each responding to a variation in both the input parameters and the behavioural properties of the engineering system.

However, engineering simulations are only representative of a reduced set of product properties and are bound by the constraints imposed by the fidelity of the underlying physics of the simulation tools being used. Therefore, hundreds of different simulation models will be required to fully represent all the scenarios identified in the product life cycle. Additionally, each scenario will require an accurate representations of the way products are likely to behave, the influence of the active environment, and of human operator involved in the task being undertaken.

Consequently, developing a new product using virtual engineering technologies demands several thousand of simulations being devised. The questions asked here are:

*"Can engineering simulations provide complete coverage of all the scenarios that represent the life cycle of a product to ensure the totality of product quality is achieved?"*

*"Can engineering simulations enable all stakeholders to be delighted by their interaction with the virtual product?"*

## VIRTUAL ENGINEERING

Virtual Engineering (VE) is concerned with integrated product and process modelling, where product models embody the design data, developed through process models. A Virtual Prototype (VP) is created when a virtual product model is embedded within a synthetic environment of the relevant life cycle phase (Figure 1). Virtual prototypes can be used to optimise the design of the product to meet the multitude of requirements across the product life cycle.

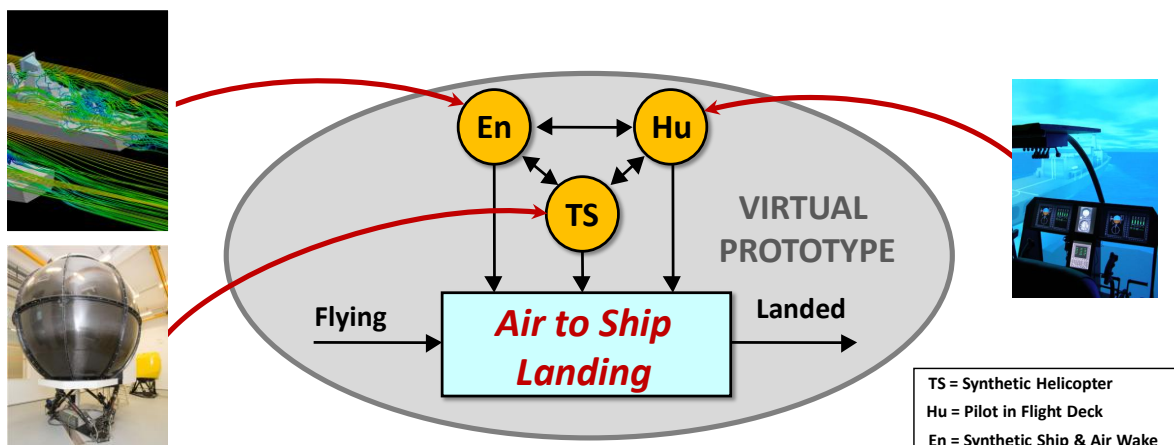

Figure 1: Example of a Virtual Prototype

At the Virtual Engineering Centre, the Theory of Technical Systems [10] has been adapted to describe the principal elements of a virtual prototype: technical system; active environment; and human operator. When these three elements are present and interacting with each other, some activity or process can be carried out. The example shown in Figure 1

represents a flight simulator: the technical system is a virtual representation of the flying behaviour of the aircraft (a helicopter); the active environment is the air flow around the ship in the vicinity of the landing pad; and the human operator is the pilot undergoing training in the flight simulator. All three elements combine to provide a real-time simulation of the air-to-ship landing scenario for which the pilot is being trained. The virtual prototype derives inputs from all three elements to control the physical behaviour of the simulator and the synthetic images displayed to the pilot in the cockpit of the simulator. The realism of the experience very much depends upon the fidelity and quality of the elements of the virtual prototype.

The expected value to be derived from VE allows credible design decisions to be pulled forward to the earliest point where they *can* be made, based on the outputs from high fidelity virtual prototypes, rather than left until they *must* be made.

The elements of the VP are derived from engineering simulations that seek to represent the behaviour of an engineering system in the context of the active environment and user operations. The Virtual Engineering Centre has developed many different types of simulation model to demonstrate the value of VE in different product life cycle scenarios.

The common feature of all these engineering simulations is that a specific functionality of the product is numerically represented with models that depict the geometric configuration of the system, its material properties, and the physics that determine its behaviour to external stimuli. The outcome of the simulation is usually a vast array of numeric data that is then used to create visualisations of the behaviour of the product (Figure 2).

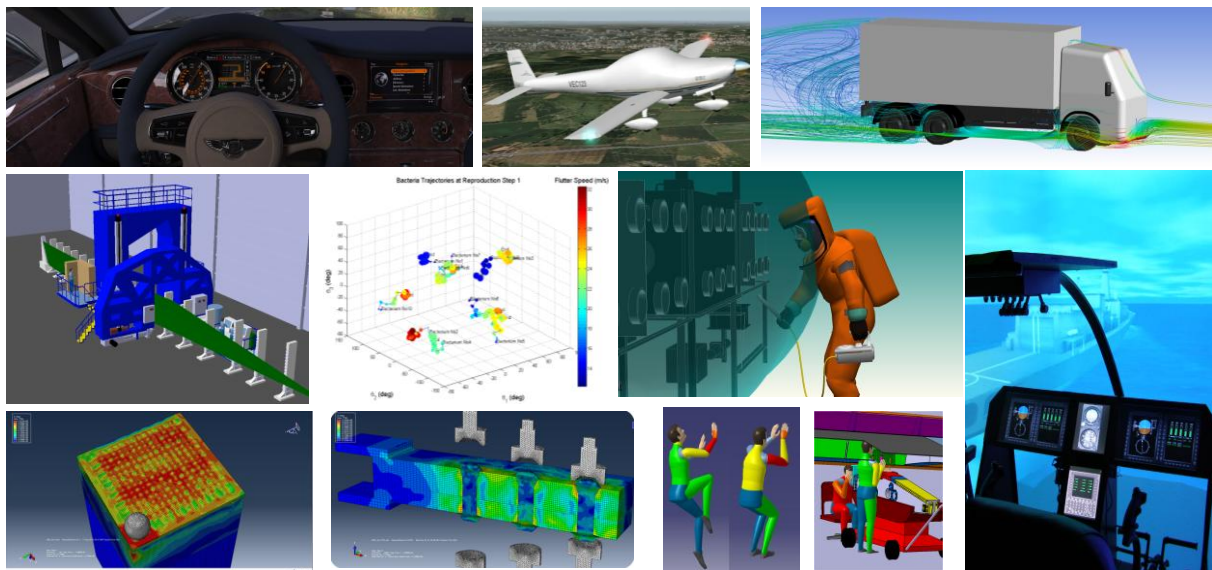

Figure 2: Examples of Engineering Simulations carried out at the VEC

Design decisions will be made on the basis of interpretation of the information these visualisations provide and selective interrogation of the underlying data where necessary. However, to achieve the coverage necessary to reflect the totality of the solution space for just one scenario requires thousands of such simulations to be performed to allow for variability of all the driving parameters.

---

## Immersive Virtual Reality

The Virtual Engineering Centre is also exploring the value of immersive virtual reality (VR) technologies to support design making decision; a full description of the VR facilities can be found in Shoa *et al* [11].



Figure 3: Immersive Virtual Reality - First Person Perspective Vehicle Interior

The primary advantage of the immersive virtual reality environment over "traditional" visualisations of engineering data is the ability to interact with the virtual product in real-time (Figure 3). This enables designers to explore many different aspects of a scenario and instantly obtain information about the variability of their own stimuli on the functionality of the virtual product. However, to achieve real-time interaction often requires engineering simulations to be simplified and limited to tasks that can be computed very quickly.

In the case studies described below, immersive VR demonstrators have been developed to assess the value of the technology to support decision making in a number of different scenarios across the product lifecycle. In all cases, the Virtual Engineering Centre has worked with virtual product data supplied by its industrial partners. Consequently, the challenge has been to ensure the fidelity of the information and data provided can be maintained in the VR environment.

## CASE STUDIES

### Case Study A: Diesel Engine Design Review- Technomot

In this case study, a 3D computer-aided design (CAD) model of a commercial diesel engine was supplied to the Virtual Engineering Centre by Technomot Limited. The 3D CAD model provided a detailed geometric representation of all of the individual components that make up the engine. The 3D CAD model was imported into an immersive VR environment, which has a number of features to support a design review scenario (Figure 4).

The immersive VR environment used here has been created with a number of standard features: a 3D CAD model of a large building- the *virtual* Virtual Engineering Centre; a virtual turntable; keyboard navigation; and user-centric tracking.

The virtual building provides an environment in which to place the diesel engine; it helps provide a sense of scale and orientation to observers when navigating through the virtual environment. In the building, we have placed a virtual turntable; it is not visible, but provides a location on which to anchor the 3D CAD model of the diesel engine.



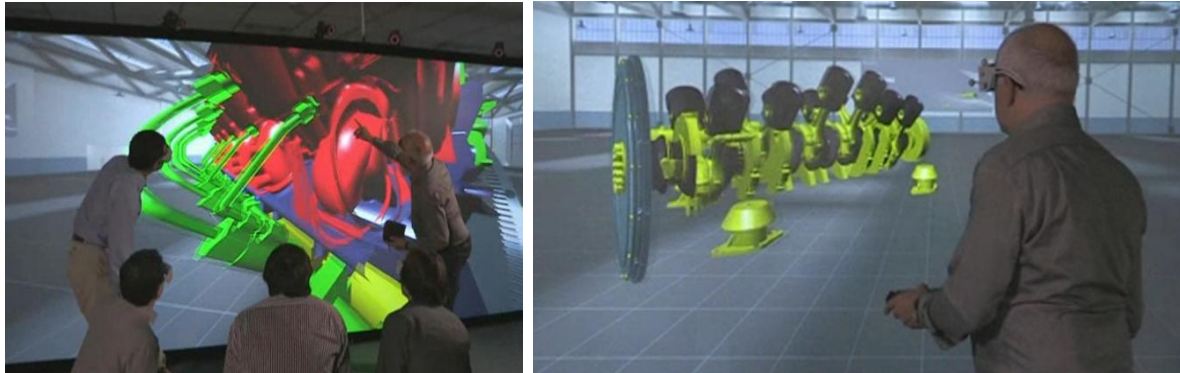

Figure 4: Immersive Virtual Reality - Design Review of a Diesel Engine

The virtual turntable provides the user with a simple means of raising/lowering/rotating the diesel engine in the virtual environment, thereby allowing inspection of the model from any desired position. Similarly, keyboard navigation allows the whole environment to be moved relative to the position of the user allowing all of the virtual factory space to be explored without limitation.

User-centric tracking determines the position of the person primarily using the VR system. At the Virtual Engineering Centre, we track the head-position of the primary user to control the virtual camera that creates the image on the VR projection screen; consequently, the primary user sees a 1:1 scale representation of the diesel engine with perspective true to their position relative to the virtual models being observed (11). In the space available, the primary user can be tracked across a 5.0m x 4.0m x 1.8m volume of space directly in front of the VR projection screen.

In addition to the features described above, the 3D CAD model of the diesel engine was modified to better support the requirements of a design review. First, different coloured materials were assigned to the surfaces of the model; this allows components to be more distinctive in appearance. Second, the components were grouped so that each group could be either visible/hidden from view; a useful feature for reviewing components that are normally obscured (Figure 4).

The primary purpose of the design review scenario represented in this demonstration was merely to inspect the spatial arrangement of the components of the diesel engine. The 3D CAD model provided by Technomot Limited included a complete representation of each component in the engine. The keyboard controls provide a simple means to position and orientate the model appropriately in an intuitive manner. However, the user-centric tracking enables the primary user to move “around” the virtual prototype being represented; in the space available, it is quite feasible to walk from one side of the engine to the other and look both underneath and on top of the engine. This manner of interaction is very natural and is not impeded by any control devices.

### **Case Study B: Glovebox Operation - National Nuclear Laboratories**

In this case study, a 3D CAD model of a glovebox was supplied to the Virtual Engineering Centre by the National Nuclear Laboratories. The glovebox model was placed in the same immersive VR environment described above with the same large building environment, virtual turntable, keyboard navigation, and user-centric tracking facilities. The primary purpose of the demonstration was to evaluate the usability of the glovebox and to assess

whether equipment located inside the box could be reached by an operator. To support this requirement, the position and orientation of the primary user's hands are tracked to control the position and orientation of virtual hand models (Figure 5). This additional VR facility provides the primary user with a means to interact with the glovebox model. For example, Figure 5 shows a hand being inserted into the glovebox through an access port; the task is to reach the pair of tweezers that are visible on the floor of the compartment.



Figure 5: Immersive Virtual Reality - Operation of a Glovebox

The life size virtual hands are a simple means of enhancing the immersive VR experience. Since the virtual hands are co-located to the real hands of the primary user, they provide an additional means for judging the size, scale and position of the components in the virtual prototype. As a consequence, it is quite feasible to make accurate judgements about whether equipment can be reached and whether operational tasks can be carried out.

Whilst this demonstration was originally conceived for assessing the design of the glovebox, it is evident that the same immersive VR environment can be used to train glovebox operatives so that they can familiarise themselves with working procedures.

### **Exterior Design Audit - Bentley Motors**

In this case study, a 3D CAD model of the Mulsanne car was supplied to the Virtual Engineering Centre by Bentley Motors Limited. The objective of the demonstration was to assess whether immersive VR could displace the need for expensive physical prototypes for design development reviews. Once again, the 3D CAD model of the Mulsanne car was placed inside the same immersive VR environment as described above. However, the 3D CAD model was modified to reduce the number of components active in the demonstration to ensure the real-time response of the VR system was acceptable (see Shao *et al* [11]). For the exterior design audit (Figure 6), the visible surfaces (A-surfaces) of the outer bodywork were the only components of the original CAD model carried over into the VR environment.

For this scenario, a number of additional VR features were introduced. Figure 6 shows a 3D pointer that allows the primary user to identify individual features of the virtual prototype using a virtual laser pointer; a small sphere at the end of the virtual laser beam touches the first surface aligned with the beam. Coupled to the 3D pointer is an inspection routine; when activated the VR display uses a close-up camera that moves around the selected feature to give a magnified view of the point of interest.



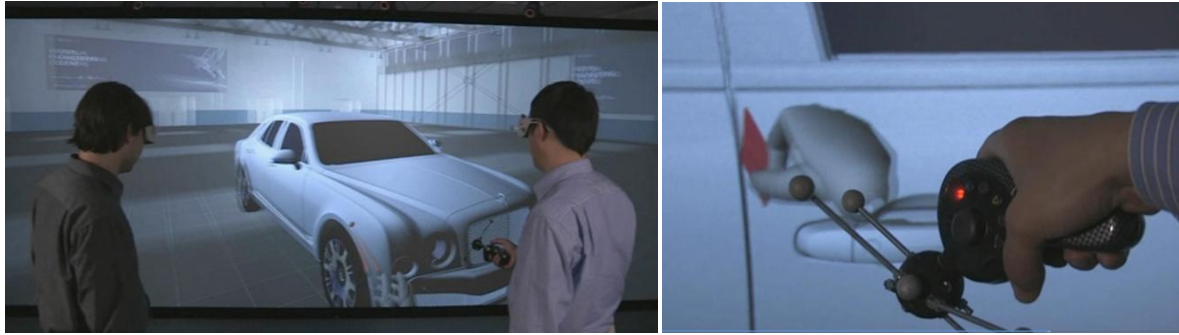

Figure 6: Immersive Virtual Reality – Exterior Design Audit

To assist with the assessment of build quality, a number of tools have been attached the virtual hands. Figure 6 shows a credit card sized “gap-tool” that can be inserted between adjacent panels. Normally the gap-tool is coloured green, however, when the tool comes in to contact with a panel surface, the tool colour changes to red. Careful positioning and orientation of the gap-tool will allow the primary user to check the nominal build condition.

Finally, to ensure a consistent approach to the design audit, a sequence of audit points has been established. At each point the position and orientation of the vehicle is pre-defined, which ensures a repeatable audit sequence has been embedded into the VR environment. However, the user-centric tracking ensures the primary user still has the freedom to move around the pre-defined audit point and inspect the virtual vehicle in a naturalistic manner.

### Interior Design Audit - Bentley Motors

In this case study, the focus of attention was the driver experience of the vehicle interior. For the interior design audit (Figure 3), the A-surfaces of the cockpit were the only elements of the original CAD model carried over into the VR environment.

Once again the virtual hand is a useful device that creates a connection between real and virtual worlds to re-enforce the true scale of the virtual vehicle in the mind of the observer. In this case the outstretched forefinger of the right hand is fully aligned to the extended tracker marker on the glove worn by the primary user; this correlation provides a powerful tool for ergonomic assessment of the vehicle interior, e.g. reach to rear-view mirror, centre console switches and dials, and sun visor (Figure 7).



Figure 7a: Immersive Virtual Reality - Ergonomic Review



Figure 7b: Immersive Virtual Reality - Ergonomic Review

To further enhance the accuracy of the immersive experience, a physical buck was supplied by Bentley Motors. The physical buck includes the driver's seat, adjustable steering column, gear shift stick, pedal box, and arm rests all of which are accurately positioned on a framework in same relative locations to each other as they are on the Mulsanne car itself (Figure 8). The physical buck and steering column are independently tracked and their position and orientation used to control the position and orientation of the virtual vehicle CAD model and virtual steering column CAD model. Thus when the primary user sits in the driver's seat they are immersed into the vehicle from the driver's point of view; using the virtual hand they can interact with both physical and virtual representations of the steering wheel and gear shift stick.

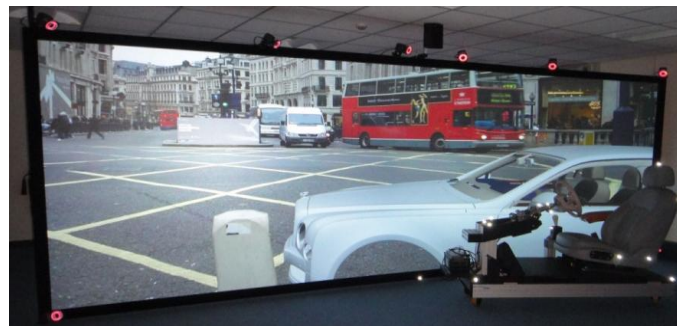

Figure 8: Immersive Virtual Reality - Integration of Virtual and Physical Worlds

The challenge was to ensure that the visualisation of the vehicle interior is completely representative of what would be experienced if sitting in a real car. This led to a number of physics based behaviours having to be simulated in real-time, whilst ensuring that the image that is displayed can be refreshed at a frequency that satisfies the observer [11].

Through collaboration with optical simulation specialists Optis, the optical properties of the materials and textures used on the virtual prototype have been measured and applied appropriately to the A-surfaces; the graphics on the instruments have been modelled in fine detail; lighting levels in the environment are representative of the interior lights of the vehicle and sunlight received from the surrounding environment; true physics based reflections have been simulated in real-time (Figure 9). However, the introduction of a high fidelity, physics based simulation does compromise the real-time response of the VR environment; for example, the ray-traced image on the left of Figure 9 takes several seconds to compute, whereas the shaded image on the right of Figure 9 can be updated several times per second.



Figure 9: Immersive Virtual Reality – Physics Based Simulation of Reflections

## DISCUSSION

The questions asked here were: *"Can engineering simulations provide complete coverage of all the scenarios that represent the life cycle of a product to ensure the totality of product quality is achieved?"* and *"Can engineering simulations enable all stakeholders to be delighted by their interaction with the virtual product?"*.

It is evident from the work carried out at the Virtual Engineering Centre that engineering simulations, *in their own right*, cannot as yet provide complete coverage of all the scenarios that represent the life cycle of product. An engineering simulation is currently limited by the extent of physical behaviour it can represent and are usually deterministic in their solution approach. Where complex physical behaviour is required to be modelled, the results of several different types of simulation will need to be integrated to form the whole solution. Where variation is required to be understood, thousands of simulations will be required to provide insight of the whole solution space.

Furthermore, engineering simulations tend not be interactive; there is usually little opportunity for human intervention in the scenario being represented. However, immersive VR environments do provide an opportunity for human interaction with the engineering simulations in real-time.

From the examples described here, immersive VR provides a design environment for the design team; an information resource shared by all; a means of communication; a means for visualising life cycle events and maintaining a high level of awareness of stakeholders' needs during design; a stimulus for creativity and synthesis; a means to monitor the progress of design work; and a means to support quality assurance efforts in design. It is feasible to achieve good quality, real-time interaction between users and the virtual prototypes, provided the fidelity of the virtual prototype is appropriate for the scenario being represented.

However, immersive VR is limited by the fidelity of the underpinning physical behaviours that can be represented. Where the VR environment is augmented by high fidelity, physics based engineering simulations, the real-time response of the system can be severely compromised. It remains a challenge of how best to integrate real-time immersive VR with high fidelity engineering simulations.

## CONCLUSIONS

Whilst virtual technologies provide opportunities to generate data and information early in the product development process, the ever increasing demands for accuracy and fidelity in representation in mature product sectors outstrips the capability of the technology to fully

---

support decision making in a complete virtual world for the many thousands of scenarios that are representative of the product life cycle. Virtual scenarios demand management: capturing/generating scenarios; structuring and co-ordination of scenarios; evolution and traceability; reviewing scenarios; and documenting scenarios.

## ACKNOWLEDGMENTS

This work was undertaken at the Virtual Engineering Centre and funded by the Northwest Regional Development Agency and European Regional Development Fund. Our thanks to Technomot Limited, National Nuclear Laboratories, Bentley Motors Limited, and Optis for their support in the development of the case studies.

## REFERENCES

1. Mørup, M., (1993), "Design for Quality", PhD thesis, Institute for Engineering Design, Technical University of Denmark, Lyngby.
2. Robotham, A.J., Andreassen, M.M.: 'The Chain of Quality through Integrated Product Development', Engineering Design in IPD, Poland, October 2000
3. Carroll, J.M., (1995), "Introduction: The scenario perspective on system development"; in *Scenario-Based Design: Envisioning work and technology in system development*, ed. by Carroll, J.M., Wiley, New York, pp. 1-17.
4. Verplank, W., Fulton, J., Black, A., & Moggridge, W., (1993), "Observation, Characterisation and Scenarios", Tutorial notes, *InterCHI 93 conference*.
5. Jarke, M., Bui, X.T., & Carroll, J.M., (1998), "Scenario management: An interdisciplinary approach", *Requirements Engineering*, 3, pp. 155-173.
6. Weidenhaupt, K., Pohl, K., Jarke, M., & Haumer, P., (1998), "Scenarios in system development: Current practice", *IEEE Software*, 15, 2, pp 34-45.
7. Jacobsen, I., (1995), "The use-case construct in object-oriented software engineering"; in *Scenario-Based Design: Envisioning work and technology in system development*, ed. by Carroll, J.M., Wiley, New York, pp. 309-336.
8. Kyng, M., (1995), "Creating contexts for design", in *Scenario-Based Design: Envisioning work and technology in system development*, ed. by Carroll, J.M., Wiley, New York, pp. 85-108.
9. Nielsen, J., (1995), "Scenarios in discount usability engineering", in *Scenario-Based Design: Envisioning work and technology in system development*, ed. by Carroll, J.M., Wiley, New York, pp. 59-84
10. Hubka, V. & Eder, W.E., (1988), "Theory of Technical Systems: A Total Concept Theory for Engineering Design", Springer-Verlag, Berlin Heidelberg.
11. Shao, F., Robotham, A.J., & Hon, B.K.K., (2012), "Development of a 1:1 Scale True Perception Virtual Reality System for Design Review in the Automotive Industry", Proc. of the 10<sup>th</sup> Int. Conf. on Manufacturing Research ICMR 2012, Birmingham.