



University of HUDDERSFIELD

University of Huddersfield Repository

Zhen, Dong, Fan, Yibo, Gu, Fengshou and Ball, Andrew

A Study of Sound Source Characteristics in Active Noise Control and Fault Diagnosis

Original Citation

Zhen, Dong, Fan, Yibo, Gu, Fengshou and Ball, Andrew (2010) A Study of Sound Source Characteristics in Active Noise Control and Fault Diagnosis. In: Inter noise 2010-39th International congress on Noise Control Engineering, 13-16 June 2010, Lisbon, Portugal. (Unpublished)

This version is available at <http://eprints.hud.ac.uk/7889/>

The University Repository is a digital collection of the research output of the University, available on Open Access. Copyright and Moral Rights for the items on this site are retained by the individual author and/or other copyright owners. Users may access full items free of charge; copies of full text items generally can be reproduced, displayed or performed and given to third parties in any format or medium for personal research or study, educational or not-for-profit purposes without prior permission or charge, provided:

- The authors, title and full bibliographic details is credited in any copy;
- A hyperlink and/or URL is included for the original metadata page; and
- The content is not changed in any way.

For more information, including our policy and submission procedure, please contact the Repository Team at: E.mailbox@hud.ac.uk.

<http://eprints.hud.ac.uk/>



A Study of Sound Source Characteristics in Active Noise Control and Fault Diagnosis

D. Zhen; Y. Fan; F. Gu; A. Ball

School of Computing and Engineering, University of Huddersfield, Huddersfield, HD1 3DH, UK
D.Zhen@hud.ac.uk

Abstract

Active noise control (ANC) is an effective technique used to reduce noise levels at the controlled points by introducing a cancellation sound wave into the primary acoustic field. To achieve better sound design and noise attenuation, it is critical to have good knowledge of the characteristics of the primary noise source, which is also necessary for condition monitoring (CM).

This paper investigates various ANC schemes to achieve both noise reduction and fault diagnosis. Firstly an effective acoustic measurement method is developed to estimate the characteristics of noise sources for the ANC in a pipeline system. Two sensors are mounted along the pipe to measure the acoustic signals and the source of the noise is estimated based on these measurements. An ANC algorithm embedded with CM capability is developed for both noise reduction and fault detection in the system. The algorithm is evaluated through both simulation study and experimental work. Preliminary results show that both noise reduction and fault diagnosis can be achieved and the system operates reliably under different operating conditions.

Keywords: Active noise control, Condition monitoring, Diesel engine, Fault diagnosis.

1 Introduction

With growing interest in condition monitoring, more and more advanced techniques are being introduced to detect and diagnose faults in machines more accurately. Acoustic methods are amongst the most useful. It has been demonstrated that the analysis of airborne acoustic signals outperforms that of vibration signals in detecting many faults from engines, gearboxes and motors [1, 2]. However, the airborne acoustic signals are inevitably influenced by background noise. In particular, when the acoustic reverberation is high, such as inside engine rooms and power stations, the reference noise signal which is a vital part in active

noise control system is hard to obtain. It is also difficult to extract condition monitoring information from the airborne acoustic signals due to the low signal to noise ratio. Cavina, N., et al develop a methodology for pre-processing the combustion time intervals in order to increase the signal-to-noise ratio to enable a more efficient misfire diagnosis [3]. Therefore, it is necessary to analyze the characteristics of the sound source for noise control and fault diagnosis in machines.

The acoustic impedance measurement method has been explored to obtain the sound source characteristics from the exhaust pressure signals measured inside an exhaust pipe in[4]. Its purpose is to obtain accurate source characteristics in a multi-component pipeline by minimizing the influence of reverberation based on the impedance calculation, and hence to produce more accurate detection and diagnosis results. The acoustic impedance measurement method was first developed for muffler and silencer design [4-6]. Because of the impressive performance of acoustic parameters for describing characteristics of acoustic sources, related subjects are investigated for numerous different kinds of fluid machines, such as pumps, fans and engines. Many works have been done in both practical and theoretical investigations.

Noise can be controlled by either passive or active techniques. Passive control is a simple and effective method to provide solutions for medium and high frequency noise. By using low cost components such as mufflers and silencers, reasonable noise control is achieved. However, for low frequency noise, passive control implies bulk and weight constraints which are often unacceptable by industry. On the other hand, active control based on the destructive interference principle, introduces a secondary noise field, known as antinoise. The antinoise is opposite in phase with the existing primary field, to provide an attenuated residual field.

Acoustical and control constraints restrict the feasibility of active systems for low frequency noise control. Therefore, when the noise consists of low, medium and high frequencies, the noise control solution should include both passive and active techniques. Active noise control is complementary, rather than being an alternative, to passive noise control. Cuesta, M. and P. Cobo [5] tried to reduce the noise radiated by a generator using passive and active noise control.

Many investigations have been carried out for determining the characteristics of the sound source in a pipeline system in order to get accurate fault diagnoses. Also a lot of researches have investigated noise control, including passive and active control. Only a few of them have considered the use of active noise control in machine condition monitoring. In this paper, the active noise control technique is used to reduce the noise in an engine exhaust pipe, and at the same time, engine fault diagnosis can be achieved by comparing the error signals obtained from the active noise control operating under different operating conditions.

2 Active noise control system (ANC)

A single input and single output (SISO) ANC system is designed to reduce the noise in the engine exhaust pipe and detect the fault of the engine operating under different conditions. There exists extensive literature reporting theoretical aspects of the performance of ANC systems in ducts and many other applications[6]. The performance of an ANC system depends on the correct interrelation between the acoustical and the control aspects, these configurable options and parameters must be chosen according with the temporal, frequency, and spatial characteristics of the noise to be canceled.

The basic feedforward ANC system used with the narrow duct is shown in figure 1. The undesired noise from a primary noise source is measured by a reference input microphone, filtered through an adaptive filter, and used to drive the controlling loudspeaker to cancel the

noise in the duct. The residual noise is detected by an error microphone and is used to update the coefficients of the adaptive filter to minimize the residual noise.

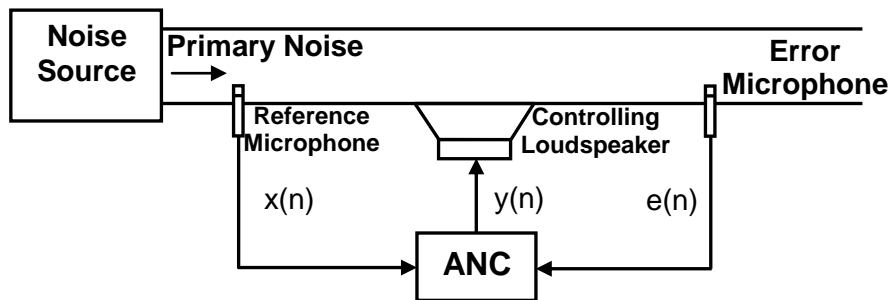

Figure 1- Single-channel feedforward ANC system in duct

In real application, a simplified form of this type of ANC system is considered as an adaptive system identification problem, in which an adaptive filter $W(z)$ is used to estimate an unknown plant $P(z)$, as shown in figure 2. The plant and the adaptive filter are assumed to be driven by the same input $x(n)$.

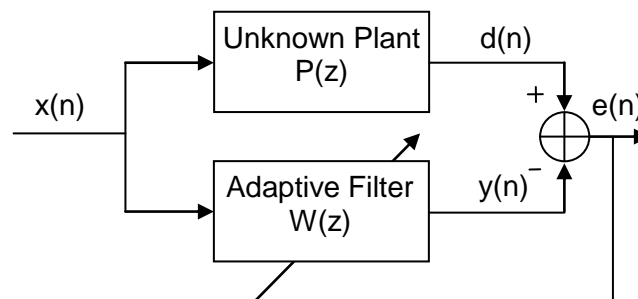

Figure 2- System identification of ANC

The identification is an adaptation process, if the plant is dynamic, the model will be time-varying. The adaptive algorithm then has the task of keeping the modeling error small by continuously tracking time variations of the plant dynamic. The primary path $P(z)$ consists of the acoustic response from the reference input sensor to the error sensor where the noise attenuation is to be realized. The objective of the adaptive filter $W(z)$ is to minimize the residual error signal $e(n)$.

From figure 2, the z-transform of $e(n)$ and $x(n)$ is denoted as $E(z)$ and $X(z)$, and it is expressed as

$$E(z) = D(z) - Y(z) = P(z)X(z) - W(z)X(z). \quad (1)$$

Ideally, $E(z) = 0$ after the adaptive filter $W(z)$ converges. From equation (1) can have

$$W(z) = P(z). \quad (2)$$

For $X(z) \neq 0$, this implies that

$$y(n) = d(n). \quad (3)$$

So the residual error is

$$e(n) = d(n) - y(n) = 0. \quad (4)$$

This results in perfect cancellation of both sounds based on the principle of acoustic superposition.

2.1 Secondary path identification

The summing junction in figure 2 represents acoustic superposition in the space from the controlling loudspeaker to the error microphone, where the primary noise is combined with the output of the adaptive filter. Therefore, it is necessary to compensate for the secondary path transfer function $S(z)$ from $y(n)$ to $e(n)$, which includes the D/A (digital-to-analog) converter, reconstruction filter, power amplifier, loudspeaker, acoustic path from loudspeaker to error microphone, error microphone, preamplifier, antialiasing filter, and A/D (analog-to-digital) converter. The secondary path response needs to be identified before using the ANC system to attenuate the primary noise.

On-line and Off-line modeling techniques are the two main methods for the secondary path identification[7]. The Off-line modeling technique is chosen to estimate the secondary path response in this paper. White noise signal is used as the input excitation signal $x(n)$, which shown in figure 3(a). The adaptive filter $W(z)$ is employed to estimate the secondary path transfer function. The function of Least-Mean-Square (LMS) algorithm is to update the coefficients of $W(z)$ to minimize the instantaneous squared error $e^2(n)$. The coefficients of $W(z)$ can be used as the estimate of the secondary path transfer function when the adaptation process is convergent. The estimation results are shown in figure 3(b), it is clear that the adaptation process is convergent after the fluctuation at the beginning.

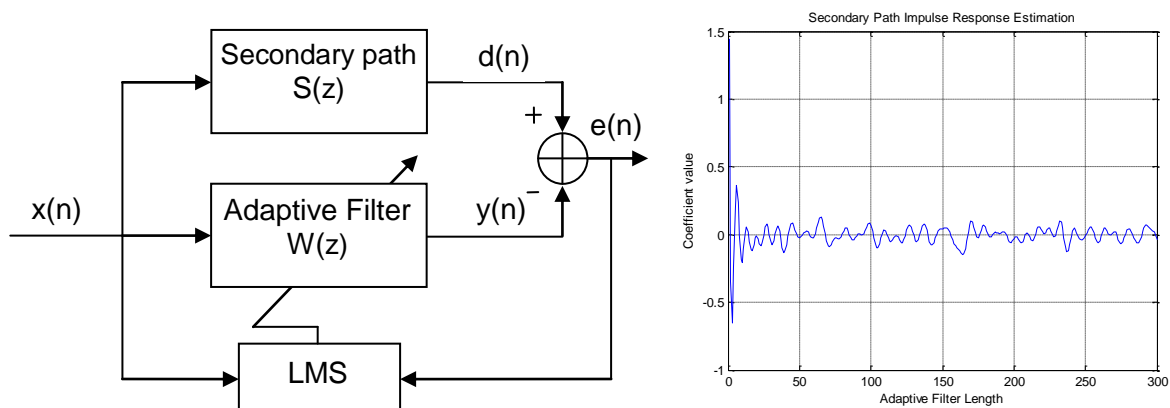

Figure 3 - Secondary path impulse estimation

2.2 The Filtered-X Least-Mean-Square (FXLMS) algorithm[6]

As discussed above, the placement of the secondary path transfer function $S(z)$, is after the adaptive filter $W(z)$ in figure 3(a). Thus the residual signal should be expressed as

$$\begin{aligned} e(n) &= d(n) - y'(n) \\ &= d(n) - s(n) * y(n) \\ &= d(n) - s(n) * [w^T(n)x(n)]. \end{aligned} \quad (5)$$

Where $s(n)$ is the impulse response of secondary path $S(z)$ at time n , and

$$w(n) = [w_0(n) \quad w_1(n) \quad \dots \quad w_{L-1}(n)]^T \quad (6)$$

$$x(n) = [x(n) \quad x(n-1) \quad \dots \quad x(n-L+1)]^T \quad (7)$$

$w(n)$ is the coefficient vector of $W(z)$ at time n , and $x(n)$ is the signal vector at time n , where L is the order of adaptive filter $W(z)$. The objective of the adaptive filter is to minimize the instantaneous squared error $e^2(n)$. The LMS is used here to update the coefficient vector in the negative gradient direction with step size μ :

$$w(n+1) = w(n) - \mu \nabla e^2(n) / 2. \quad (8)$$

Where $\nabla e^2(n)$ is an instantaneous estimate of the Mean-Square-Error (MSE) gradient at time n , and can be expressed as

$$\nabla e^2(n) = 2[\nabla e(n)]e(n). \quad (9)$$

From equation (5)

$$\nabla e(n) = -s(n) * x(n) = -x'(n). \quad (10)$$

Therefore, the gradient estimate becomes

$$\nabla e^2(n) = -2x'(n)e(n). \quad (11)$$

Where

$$x'(n) = [x'(n) \quad x'(n-1) \quad \dots \quad x'(n-L+1)]^T. \quad (12)$$

$$x'(n) = s(n) * x(n). \quad (13)$$

So the FXLMS algorithm is:

$$w(n+1) = w(n) + \mu x'(n)e(n). \quad (14)$$

The FXLMS algorithm used in ANC system is shown in figure 4. It shows that when a transfer function follows the adaptive filter, this transfer function must also be placed in the weight update path. The transfer function $S(z)$ is unknown in practical applications, and it needs to be estimated using the secondary path identification methods, so using $\hat{S}(z)$ instead of $S(z)$.

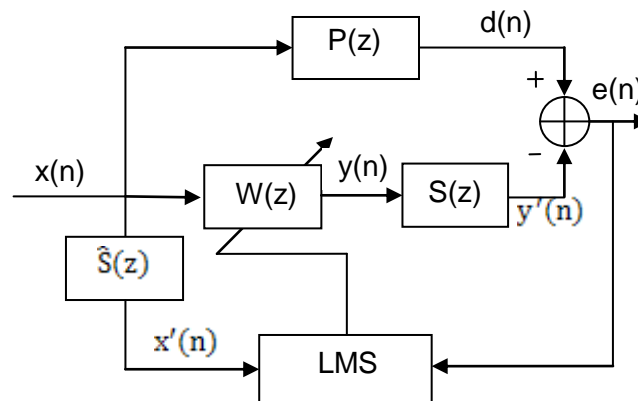

Figure 4 – Block diagram of ANC system using FXLMS algorithm

2.3 Reference signal

A good quality reference signal, coherent with the primary noise, is paramount for the performance of a feedforward ANC system. The input signal from the reference sensor must be well correlated with the noise from the primary source. When the reference sensor is an acoustical sensor, such as microphone, the acoustical reference signal picked up from the reference microphone not only includes the primary noise information, but also contains the acoustic wave from the controlling loudspeaker. The coupling of the acoustic wave from the controlling loudspeaker to the reference microphone is called acoustic feedback[6], which introduces poles on the transfer function between the control source and the reference sensor, and can cause the control algorithm to become unstable. In order to avoid the acoustical feedback, the best alternative is to use a non-acoustical reference.

In this paper, for the engine noise control and fault diagnosis, the pressure signal propagating in the exhaust pipe, which is calculated by the two sensors measurement method that is mentioned in [4], is chosen as the reference signal for the ANC system.

3 Simulation study

The residual error signals are detected by an error microphone and are used to update the coefficients of the adaptive filter in the FXLMS algorithm to minimize the residual noise. In theory, the error signal will be approximated to zero when the algorithm is convergent and the ANC system is stable. The simulation residual signals in a stable ANC system are shown in figure 5(c). The reference signal in this simulation is a single-frequency signal with 250Hz,

which is shown in figure 5(a). There a slight difference between the signals in figure 5(a) and (b), which is difficult to distinguish directly.

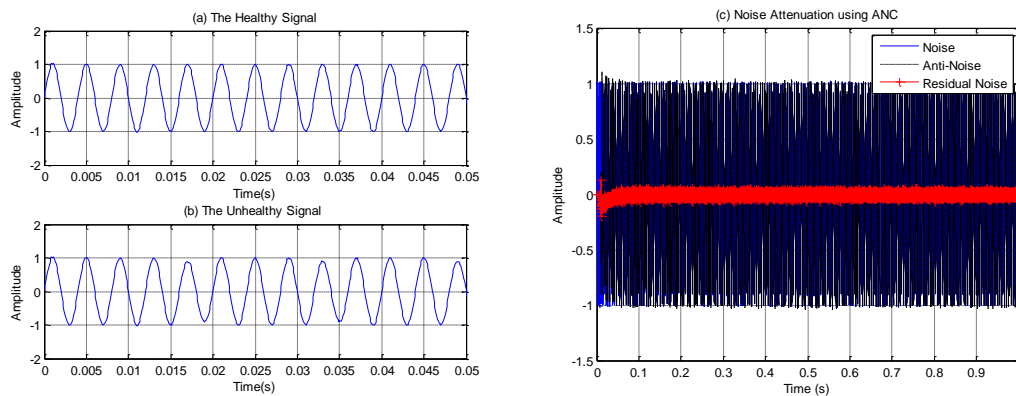

Figure 5 - The simulation of healthy and fault engine exhaust signals

Figure 5(c) indicates that the amplitude of the error signals is fluctuating at the beginning, this is because the adaptive filter needs time to adjust its coefficient to get the optimal ones for calculating the control signal, but when the algorithm is convergent and stable, the error signals is also stable. The effect of noise attenuation is clear through comparing the noise with the residual noise in figure 5(c).

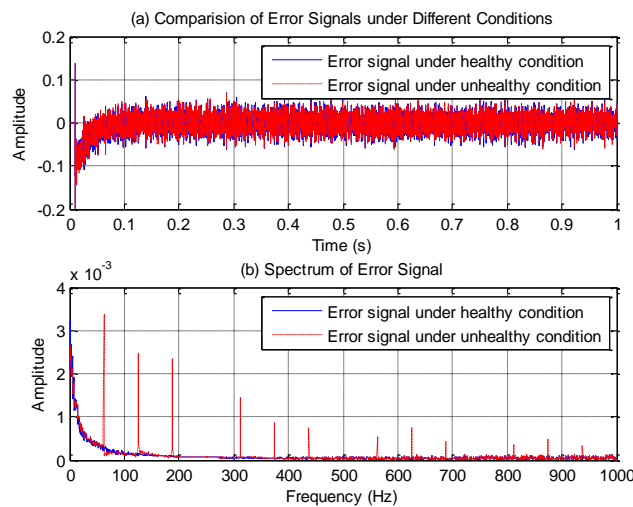

Figure 6 - The analysis of error signals in simulation

The analysis results of the error signal obtained from noise attenuation is shown in figure 6. Comparing the error signals under healthy condition (bold) with error signals under unhealthy condition (dashed), it was found that the error signals under unhealthy condition have more abnormal components in the frequency domain as shown in figure 6(b). So the faults of the engine can be detected through analyzing the residual signals during the process of noise reduction.

4 Experimental study

In the experiment, a test pipe is connected to a speaker fed with engine exhaust noise recorded from a diesel engine. The noise is reduced in the test pipe using ANC. The reference signal is obtained by the two sensors measurement method which was mentioned above. Figure 7(a) and (b) show the healthy and faulty engine exhaust noise respectively. The feature of a fault cannot be extracted from the two signals just as analysis in simulation.

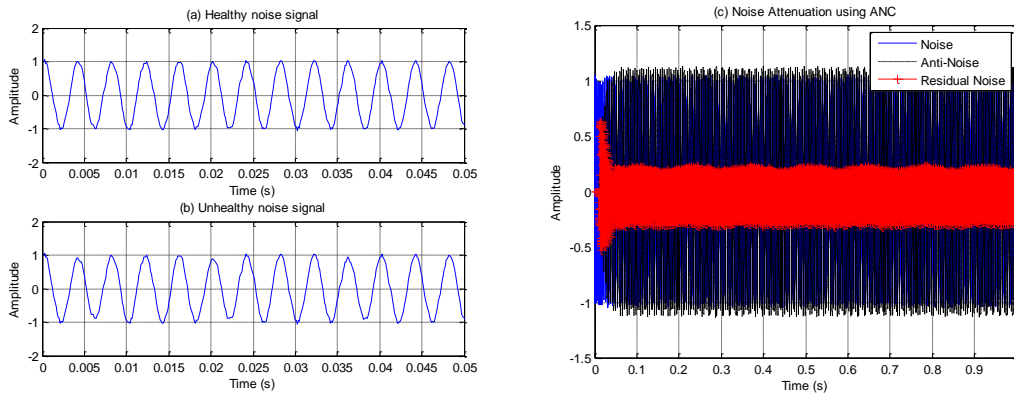

Figure 7 - The experimental healthy and fault engine exhaust signals

The effect of noise reduction is presented in figure 7(c). The noise attenuation system is active when the ANC system became stable after the algorithm is convergent. The reduction of the noise is about 3dB, this is calculated by comparing the original noise with the residual noise.

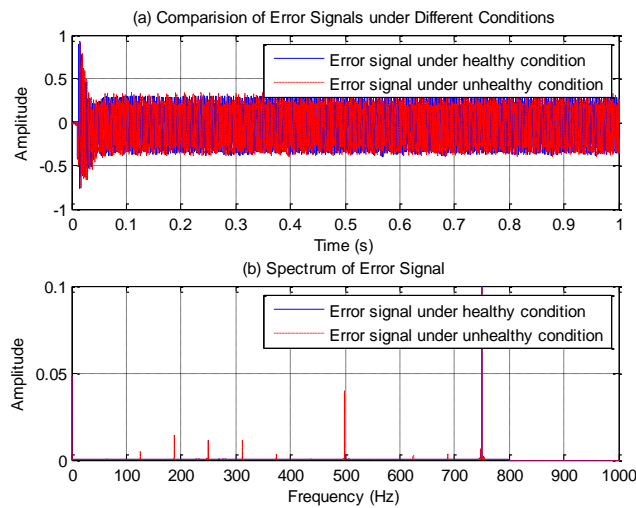

Figure 8 - The analysis of experimental error signals

The analysis of the error signals obtained from ANC system is shown in figure 8. In the time domain, it was found the error signal fluctuated at the beginning and then converged. It remained stable due to the adaptive process of the algorithm. In the frequency domain, which is shown in figure 8(b), some excrement components were found comparing the error signals under healthy condition (bold line) with error signals under unhealthy condition (dashed line).

5 Conclusions

In this paper, a classic ANC algorithm (FXLMS) based on the principle of acoustic wave superposition was used for noise reduction. In addition, the CM methods are also included in the process of noise attenuation in order to develop fault diagnosis. The healthy and faulty signals are studied both theoretically and experimentally for both reducing low frequency noise in a pipeline system and for monitoring abnormal changes in sources. The experimental results show that the effect of the noise reduction is significant and diagnoses information can be extracted through analyzing the residual noise of the ANC system, especially in frequency domain. Therefore, it has been demonstrated that it is feasible to realise simultaneous CM and ANC with a single system. Thus it allows full use of hardware resources available.

References

- [1] Li, W.; et al. A STUDY OF THE NOISE FROM DIESEL ENGINES USING THE INDEPENDENT COMPONENT ANALYSIS. *Mechanical Systems and Signal Processing*, 2001. **15**(6): p. 1165-1184.
- [2] G.Ramroop; et al. Airborne Acoustic Condition Monitoring of a Gearbox System. *2001 5th Annual Maintenance and Reliability Conference (MARCON 2001)*, May 2001, Gatlinburg, Tennessee, USA, 2005.
- [3] Cavina, N.; et al. A methodology for increasing the signal to noise ratio for the misfire detection at high speed in a high performance engine. *Control Engineering Practice*, 2006. **14**(3): p. 243-250.
- [4] Jiang, J.; et al. Monitoring of diesel engine combustions based on the acoustic source characterisation of the exhaust system. *Mechanical Systems and Signal Processing*, 2008. **22**(6): p. 1465-1480.
- [5] Cuesta, M.; P. Cobo. Active control of the exhaust noise radiated by an enclosed generator. *Applied Acoustics*, 2000. **61**(1): p. 83-94.
- [6] M.Kuo, S. and D.R. Morgan, *Active Noise Control Systems-Algorithms and DSP Implementations*. 1996.
- [7] Fujii, K.; J. Ohga. Method to update the coefficients of the secondary path filter under active noise control. *Signal Processing*, 2001. **81**(2): p. 381-387.