



UNIVERSITÀ DEGLI STUDI DI PALERMO

DIPARTIMENTO DI BIOMEDICINA SPERIMENTALE E
NEUROSCIENZE CLINICHE (BIONEC)

Dottorato in Fisiopatologia Neurosensoriale

Il trattamento con RSV e l'espressione transgenica di PGC-1 α proteggono i neuroni dopaminergici nel modello MPTP murino del morbo di Parkinson.

**Resveratrol treatment and transgenic expression of PGC-1 α protect
dopaminergic neurons in the MPTP mouse model of Parkinson's disease.**



Settore scientifico disciplinare BIO/09

TESI DI
DOTT.SSA MELANIA OLIVIERI

COORDINATORE DEL DOTTORATO
PROF. GIUSEPPE FERRARO

TUTOR
PROF. NATALE BELLUARDO

Cover Figure- Scheme showing dopaminergic neurons projecting from the substantia nigra pars compacta to the striatum.

Table of contents

<i>Table of contents</i>	<i>i</i>
<i>Paper included in the thesis</i>	<i>iii</i>
<i>Abbreviations</i>	<i>iv</i>
<i>Summary</i>	<i>v</i>
<i>Background</i>	<i>1</i>
Involvement of oxidative stress in Neurodegenerative diseases	1
Role of oxidative stress in the pathogenesis of Parkinson's disease (PD)	2
Oxidative stress in MPTP model of PD	5
Neuroprotective strategies against oxidative stress in PD.....	8
Antioxidative effects of RSV against oxidative stress	11
Role of RSV in Neuroprotection and in Neurodegenerative diseases treatment.....	13
PGC-1 α play an important role in Neurodegenerative diseases.....	15
<i>Aims</i>	<i>20</i>
Aim 1	20
Aim 2	20
<i>Materials and methods</i>	<i>21</i>
Animals.....	21
Generation of PGC-1 α transgenic mice.....	21
Drug treatments	22
Immunohistochemistry	23
Preparation and immunoblotting of different brain regions	24
Cell cultures and immunoblotting	25
Immunoprecipitation of PGC-1 α	26
Transfection and promotor assays	26
ROS measurements	26
Quantitative RT-PCR	27
High-pressure liquid chromatography (HPLC)	27
Isolation of mitochondria and measurement of respiratory control	28
Quantitative evaluations and statistics.....	28

<i>Results</i>	29
Neuroprotective effects of RSV in dopaminergic neurons in vivo	29
MPTP lesion and neuroprotective effect of RSV treatment evaluated by optical count of dopaminergic neurons in the SNc.....	29
MPTP lesion and effects of RSV treatment on density of dopaminergic fibers in the striatum evaluated by western blotting and immunohistochemistry	30
RSV treatment enhances antioxidant enzyme SOD2 levels in SN.....	32
RSV treatment enhances DAT expression in the striatum of female mouse.....	32
Estrogen receptors mediate RSV effect on DAT.....	34
Mechanisms of RSV-mediated cell protection as studied in dopaminergic cells	36
Neuroprotective effect of RSV in SN4741 cells exposed to oxidative stress.....	36
Effect of RSV on expression of antioxidant enzymes SOD2 and Trx2 in SN4741 cells	36
Effect of RSV on expression of PGC-1 α in SN4741.....	37
Effect of RSV on gene transcription of PGC-1 α in SN4741.....	39
PGC-1 α transgenic mice are protected against MPTP-induced cell degeneration.....	40
Analyses of transgenic mice with overexpression of PGC-1 α in brain and in dopaminergic neurons.....	40
Effects of overexpression of PGC-1 α on mitochondrial antioxidants SOD2 and Trx2 and on the mitochondrial enzyme COXIV in SN	41
PGC-1 α protects against MPTP-induced neuronal degeneration in vivo in the SN.....	42
PGC-1 α protects against MPTP-induced neuronal degeneration in vivo in striatum...	43
PGC-1 α counteracts the decrease in striatal DA and DOPAC levels induced by MPTP	44
PGC-1 α affects the respiration of isolated brain mitochondria	45
<i>Discussion</i>	46
Neuroprotective effects of RSV in dopaminergic neurons in vivo	46
RSV effect on DAT expression in the striatum of female mouse	47
Mechanisms of RSV-mediated dopaminergic cell protection.....	49
PGC-1 α transgenic mice are protected against MPTP-induced cell degeneration.....	51
<i>Conclusions</i>	53
<i>Acknowledgements</i>	54
<i>Papers published during doctorate</i>	55
<i>Reference List</i>	56

Paper included in the thesis

Di Liberto V., Mäkelä J., Korhonen L., Olivieri M., Tselykh T., Mäkiä A., Do Thi H., Belluardo N., Lindholm D., Mudò G. Involvement of estrogen receptors in the RSV-mediated increase in dopamine transporter in human dopaminergic neurons and in striatum of female mice. *Neuropharmacology*. 2011 Oct 24.

Mudò G., Mäkelä J., Di Liberto V., Tselykh T.V., Olivieri M., Piepponen P., Eriksson O., Mäkiä A., Bonomo A., Kairisalo M., Aguirre J.A., Korhonen L., Belluardo N., Lindholm D. Transgenic expression and activation of PGC-1 α protect dopaminergic neurons in the MPTP mouse model of Parkinson's disease. *Cell Mol Life Sci*. 2011 Oct 8.

Abbreviations

AD, Alzheimer's disease;
ALS, amyotrophic lateral sclerosis;
AMPK, 5' AMP-activated protein kinase;
ATP, Adenosine triphosphate;
cAMP cyclic adenosine monophosphate;
CNS, central nervous system;
COX IV, cytochrome c oxidase IV;
CoQ10, il coenzim Q10;
DAT, dopamine active transporter;
ERR α , estrogen-related receptor alpha;
GAPDH, Glyceraldehyde 3-phosphate dehydrogenase;
HAT, Histone Acetyltransferase;
HD, Huntington's disease;
HO1, Heme oxygenase;
iNOS, inducible NO synthase;
MAO, monoamine oxidase;
MPP⁺, 1-methyl-4- phenyl-pyridinium ion;
MPTP, 1-methyl-4-phenyl- 1, 2, 3, 6-tetrahydropyridine;
mtTFA, mitochondrial transcription factor A;
NO, nitric oxide;
NRF, nuclear respiratory factor;
PGC-1 α , peroxisome proliferator-activated receptor gamma coactivator 1-alpha;
PD, parkinson's disease;
RNS, reactive nitrogen species;
RSV, 3,4',5-trihydroxystilbene;
ROS, reactive oxygen species;
SIRT, Sirtuin;
SNc, substantia nigra pars compacta;
SOD, superoxide dismutases;
TaClo, 1-trichloromethyl-1,2,3,4-tetrahydro- β -carboline;
TLZ, temporal lobe epilepsy;
VMAT2, the vesicular monoamine transporter 2.

Summary

Accumulating evidence indicates that multiple factors, including genetic and environmental ones, contribute to dopaminergic neuron degeneration in Parkinson's disease (PD) (de Lau and Breteler 2006; Schapira et al. 2009; Gupta et al. 2008). Particularly, alterations in mitochondrial functions (Banerjee et al. 2009; Abou-Sleiman et al. 2006) with an increased production of reactive oxygen species (ROS) have been associated with degeneration of midbrain dopaminergic neurons (Zhou et al. 2008).

Increasing number of *in vitro* and *in vivo* studies demonstrated the efficacy of polyphenolic antioxidants to reduce or to block neuronal death occurring in the pathophysiology of some neurodegenerative disorders (Ramassamy 2006). Particularly, Resveratrol (3,4',5-trihydroxystilbene, RSV), a polyphenol primarily found in grapes and red wine, has attracted considerable interest as being a free radical scavenger and potent antioxidant that enhances the activities of a variety of antioxidant enzymes (Baur et al. 2006). Therefore, on the basis of these observations, using different approaches, the first aim of present study was to analyze neuroprotective effects of RSV in MPTP-mouse model of PD, inducing death of dopaminergic neurons in the substantia nigra pars compacta (SNc), and in dopaminergic neuronal (cell lines SN4741) exposed to oxidative stress.

In both these models we could show a significant neuroprotective effect of RSV on dopaminergic neurons. The investigation was also extent to mechanisms involved on neuroprotective effect of RSV. RSV enhanced the levels of the mitochondrial antioxidants, superoxide dismutases 2 (SOD2) and thioredoxin (Trx), and both the levels and activity of transcriptional coactivator of peroxisome proliferator-activated receptor- γ (PGC-1 α). Results obtained revealed that the beneficial effect of RSV was dependent on its effects on PGC-1 α . During the course of these experiments, both *in vivo* and *in vitro* (cell lines SN4741), we observed unexpectedly that RSV treatment leads to a strong increase of dopamine transporter (DAT) expression in the striatum only in female mice. Since RSV is a phytoestrogen with striking similarity to the synthetic estrogen diethylstilbestrol, we also showed that the effect of RSV on DAT expression involves estrogen receptor activation by RSV.

On the basis of results revealing an increased levels and activity of PGC-1 α after treatment with RSV, as second aim of this work, the neuroprotective role of PGC-1 α was explored in MPTP mouse model of Parkinson's disease, using transgenic mice overexpressing PGC-1 α (PGC1-tg). Transgenic mice overexpressing PGC-1 α in DA neurons were protected against cell degeneration induced by MPTP treatments. The levels of the mitochondrial antioxidants, SOD2 and Trx2 were found increased in the SN of PGC-1 α transgenic mice compared with wild-type animals. Likewise, the mitochondrial enzyme cytochrome c oxidase IV (COX IV) was also elevated in the transgenic mice compared to controls. The increase in protein levels in the PGC-1 α transgenic mice was accompanied by an enhanced gene expression, as shown here for SOD2 and COX IV using RT-PCR. This shows that overexpression of PGC-1 α leads to changes in gene expression for a particular set of proteins in the SN with a potentially protective function in cell stress.

Taken together the findings of this work suggest that RSV shows a neuroprotective effects in dopaminergic neurons both in vitro and in vivo and the results reveal an important function of the PGC-1 α signaling in DA neurons to combat oxidative stress; furthermore, it may be possible to modulate both the activity and levels of PGC-1 α by RSV in neurons to increase neuronal viability and to treat oxidative stress on different neurological diseases including PD.

Background

Involvement of oxidative stress in Neurodegenerative diseases

Mammalian life depends upon oxygen as the final acceptor of electrons in mitochondrial electron transport for energy production; these reactions in turn produce ROS (Liu et al. 2002;Phillips et al. 2003), such as superoxide anions, hydrogen peroxide, hydroxyl radical, peroxy radicals, and reactive nitrogen species (RNS). While these reactive species are important for execution of physiological functions, a their excessive production is detrimental to cell membranes and can cause cell death (Loh et al. 2006). Biological systems have evolved with endogenous defense mechanisms to help protect against free radical-induced cell damage. Glutathione peroxidase, catalase, and SOD are antioxidant enzymes, which metabolize toxic oxidative intermediates (Fang et al. 2002). They require micronutrients as cofactors such as selenium, iron, copper, zinc, and manganese for optimum catalytic activity and effective antioxidant defence mechanisms (Halliwell and Gutteridge 1992;Halliwell 2001). The disturbance in the balance between the production of ROS, or free radicals and antioxidant defenses, which may lead to tissue injury, has been defined "oxidative stress".

The central nervous system (CNS) is especially vulnerable to oxidative stress because of brain's high oxygen consumption, its abundant lipid content, and the relative paucity of antioxidant enzymes as compared with other tissues (Skaper et al. 1999;Roediger and Armati 2003). Moreover, brain has a high ratio of membrane surface area to cytoplasmic ratio, extended axonal morphology prone to injury, and neuronal cells are non-replicating. ROS can increase the permeability of the blood brain barrier, alter tubulin formation, and inhibit the mitochondrial respiration. If unchecked, it can lead to a geometrically progressing lipid peroxidation. Evidence also indicate that ROS may stimulate extracellular release of excitatory aminoacids (Gilman et al. 1993;Rasheed et al. 2010). Glutamate is the major excitatory aminoacid in the brain. It acts through various types of ionotropic receptors, the most significant being, NMDA receptors (Ross et al. 2011). There seems to be a bi-directional relationship between the

ROS production and release of excitatory aminoacids (Coyle and Puttfarcken 1993;Alexandrova and Bochev 2005). Free radicals generated in the brain are also reported to influence gene expression, subsequently effecting apoptosis and neuronal death (Gilgun-Sherki et al. 2002;Gupta et al. 2003).

There is substantial evidence that mitochondrial dysfunction and oxidative stress are a causative or at least ancillary factor in the pathogenesis of major neurodegenerative diseases, including PD, Alzheimer's disease (AD), Huntington's disease (HD) and amyotrophic lateral sclerosis (ALS) as well as in cases of stroke, trauma, and seizures (Beal et al. 2000;Ienco et al. 2011); moreover, oxidative stress is a common pathogenic mechanism underlying many major psychiatric disorders (Wang et al. 2009). Infact, the loss of the redox balance implies a loss of regulation of the inflammatory response, which then causes a reparative and self-limiting response (Floyd et al. 2011). This becomes a perpetual response, a vicious cycle, in which there is mitochondrial failure that leads to a lack of adenosine triphosphate (ATP), an increase in the state of oxidative stress, loss of regulation of inflammatory markers, blocking of antioxidant systems, inability to synthesize new proteins, disorders of the proteasome, accumulation of misfolded proteins and, the conformational change in key receptors involved in metabolism and cell signaling (Sevcsik et al. 2011). All of them, established slowly over time, can produce chronic degenerative diseases and neurodegenerative diseases as a manifestation of a series of alterations caused by multiple factors, including that of the establishment of a state of chronic-oxidative stress (Halliwell 2006).

Role of oxidative stress in the pathogenesis of Parkinson's disease (PD)

Parkinson's disease is a common adult-onset neurodegenerative disorder. PD is clinically characterized by the tetrad of motor manifestations of tremor, rigidity, slowness of voluntary movements, and poor balance (Fahn 2003). PD arises essentially as a sporadic condition, that is, in absence of any evidence of genetic linkage, but, in a handful of cases, it is inherited (Dauer and Przedborski 2003). These rare occurrences can be from a variety of genetic defects, such as mutations in α -synuclein (Polymeropoulos et al. 1997), parkin (Kitada et al. 1998), DJ1 (Bonifati et al. 2003), PINK1 (Valente et al. 2004), and LRRK2 (Zimprich et al. 2004;Paisan-Ruiz et al. 2004)

which are transmitted as either dominant or recessive Mendelian traits (Vila and Przedborski 2004). That being said, clinically both the sporadic and the familial forms of PD are almost indistinguishable and they share the same basic biochemical hallmark, that is, a profound deficit in brain dopamine. The reason for this reduction in brain dopamine is because all of the ascending dopaminergic pathways in the CNS degenerate, albeit to variable degrees (Hornykiewicz and Kish 1987). For instance, among these pathways, the nigrostriatal pathway-which is composed of dopaminergic neurons residing in the ventral midbrain nucleus, called the SN, and which projects upward to the striatum, is consistently the most severely affected. It is important to stress, however, that PD neurodegeneration is not restricted to the dopaminergic systems as widespread neuronal loss can be detected in other catecholaminergic and noncatecholaminergic nuclei (Braak et al. 1995; Braak et al. 1995). Thus, if the main motor manifestations of PD are likely linked to neurodegeneration in the dopaminergic systems, nonmotor manifestations of PD, such as pain, cognitive impairments, and constipation, are more likely linked to neurodegeneration in these nondopaminergic pathways.

Two other prominent features of PD neuropathologies include the presence of intraneuronal proteinaceous inclusions, called Lewy bodies, which are insoluble protein aggregates mainly composed of α -synuclein, found within many of the spared neurons in nearly all affected brain areas (Shults 2006) and gliosis (Przedborski 2007).

The etiology of PD is unknown; however it is believed to be due to one or more of the following: age, genetics and/or environmental factors such as pesticides (Miller et al. 2007). 1-methyl-4-phenyl- 1, 2, 3, 6-tetrahydropyridine (MPTP) is a chemical that is related to the opioid analgesic drugs. MPTP is oxidized by monoamine oxidase B (MAO-B) to form 1-methyl-4- phenyl-pyridinium ion (MPP⁺), which is taken up by dopaminergic neurons and leads to cell death. It has been reported (Langston et al. 1984) that injections of MPTP in squirrel monkeys resulted in parkinsonism. However, oxidative stress has been hypothesized to be linked to both the initiation and the progression of PD. Preclinical findings from both in vitro and in vivo experimental models of PD suggest that the neurodegenerative process starts with otherwise healthy neurons being hit by some etiological factors, which sets into motion a cascade of deleterious events. In these models initial molecular alterations in degenerating dopaminergic neurons include increased formation of reactive oxygen species,

presumably originating from both inside and outside the mitochondria (Zhou et al. 2008).

A number of studies have searched for indices of oxidative stress in autopsy materials obtained from PD patients. These markers come in different flavors since ROS and RNS can damage virtually all biological macromolecules. First oxidative metabolism of dopamine itself (Graham et al. 1978) exposes dopaminergic neurons of the SNc to chronic oxidative stress compared to other regions of the brain. Dopamine as a neurotransmitter is stable in the synaptic vesicle, but when an excess amount of cytosolic dopamine exists outside of the synaptic vesicle in the damaged neurons, dopamine is easily metabolized via MAO or by auto-oxidation to produce cytotoxic ROS (Sulzer et al. 2000). In the oxidation of dopamine by MAO, H_2O_2 and dihydroxyphenylacetic acid (DOPAC) are generated. In contrast, non-enzymatical and spontaneous auto-oxidation of dopamine produces O_2^- and reactive quinones (Graham 1978). Generated O_2^- is converted to H_2O_2 by SOD and O_2^- also reacts with nitric oxide radicals ($NO\cdot$) to consequently generate peroxynitrite. In the dopaminergic neurons, where metals are abundant, H_2O_2 can react with metals, especially iron, to form the most cytotoxic radical ($OH\cdot$). Enzymatic oxidation of dopamine to H_2O_2 causes also increased formation of oxidized glutathione, suggesting the occurrence of oxidative stress and impairment of a major antioxidant system (Spina and Cohen 1988).

Mitochondrial dysfunction is also an intrinsic aspect of an oxidative stress hypothesis due to their major role in the production of cellular ROS. Consistent deficits in the subunits and activity of mitochondrial complex I (NADH ubiquinone Oxidoreductase) of the electron transport chain in blood platelets and SNc of PD patients is a prominent phenomenon (Keeney et al. 2006;Beal 2005), suggesting central role of mitochondrial dysfunction in PD. A recent study demonstrated that SNc neurons have high amount of mitochondrial DNA (mtDNA) deletions in postmortem PD patients when compared with other neuronal populations in brain- and age-matched controls (Bender et al. 2006). A related study identified that nigral neurons from PD patients contain high levels of clonally expanded somatic mtDNA deletions leading to mitochondrial dysfunction (Kraytsberg et al. 2006). Also a decrease in the function of Complex III has also been reported in the lymphocytes and platelets of PD patients (Shinde and Pasupathy 2006). Studies of families who suffer from inherited forms of PD have identified a number of genes encoding mitochondrial proteins or proteins implicated in mitochondrial dysfunction (Oakley et al. 2007). Moreover, mitochondrial

DNA is particularly susceptible to oxidative damage, because of its vicinity with ROS source (electron transport chain) and because it is not protected by histones and is inefficiently repaired. Furthermore, NO accumulation can form adducts with mitochondrial enzymes and dysregulate mitochondrial function (Ebadi and Sharma 2003; Yamamoto et al. 2007).

Recent studies suggest that also Endoplasmatic Reticulum stress by accumulation of unfolded and/or misfolded proteins contribute to PD (Wang and Takahashi 2007). Finally, inflammation can also contribute to ROS production and has been implicated in the pathogenesis of PD; infact, activation of microglia in response to injury is associated with an upregulation of inducible nitric oxide synthase (iNOS) resulting in increased production of NO (Drechsel and Patel 2008).

Oxidative stress in MPTP model of PD

Animal models are an invaluable tool for studying the pathogenesis and therapeutic intervention strategies of PD by toxin-induced Parkinsonism. Infact, there is extensive evidence that PD can be caused by neurotoxins, specifically MPTP (Davis et al. 1979), rotenone (Greenamyre et al. 1999), paraquat (Liou et al. 1997), diquat (Sechi et al. 1992), and 1-Trichloromethyl-1,2,3,4-tetrahydro- β -carboline (TaClo) (Bringmann et al. 1995a; Bringmann et al. 1995b). These compounds are thought to act via various mechanisms, but all by causing mitochondrial dysfunction. To date, MPTP remains the best characterized PD model and has provided the strongest support for the role of oxidative stress in disease pathogenesis. MPTP is a by-product of the chemical synthesis of a meperidine analog with potent heroin-like effects (Langston and Irwin 1986).

In humans and non-human primates, depending on the regimen used, MPTP can produce an irreversible and severe parkinsonian syndrome that replicates almost all of the features of PD, including tremor, rigidity, slowness of movement, postural instability, and even freezing (Przedborski et al. 2001). The most frequently used animals for MPTP studies are monkeys, mice and rats. The administration of MPTP through a number of different routes using different dosing regimens has led to the development of several distinct models, each characterized by some unique behavioral

and/or biochemical features. MPTP is a lipophilic protoxin that readily crosses the blood brain barrier and is converted to MPP^+ by MAO-B in astrocytes (Nicklas et al. 1985). Subsequently, MPP^+ produced is then released from astrocytes and taken up by dopaminergic neurons (Schober 2004) by binding to DAT with high affinity (fig. 1) and accumulated to high levels in mitochondria where MPP^+ inhibits mitochondrial Complex I (NADH quinone oxidoreductase) (fig. 2) (Nicklas et al. 1987). This inhibition of Complex I leads to cell death via energy deficits (Przedborski et al. 2000), free radical and ROS generation (Cleeter et al. 1992) and possibly excitotoxicity (Bezard et al. 2006). Inside neurons, MPP^+ can also bind to the vesicular monoamine transporter-2 (VMAT2), which translocates MPP^+ into synaptosomal vesicles (Schober 2004). This uptake system serves as a detoxification mechanism and mice with depletion of vesicular monoamine transporters are more sensitive to MPP^+ toxicity (Schober 2004).

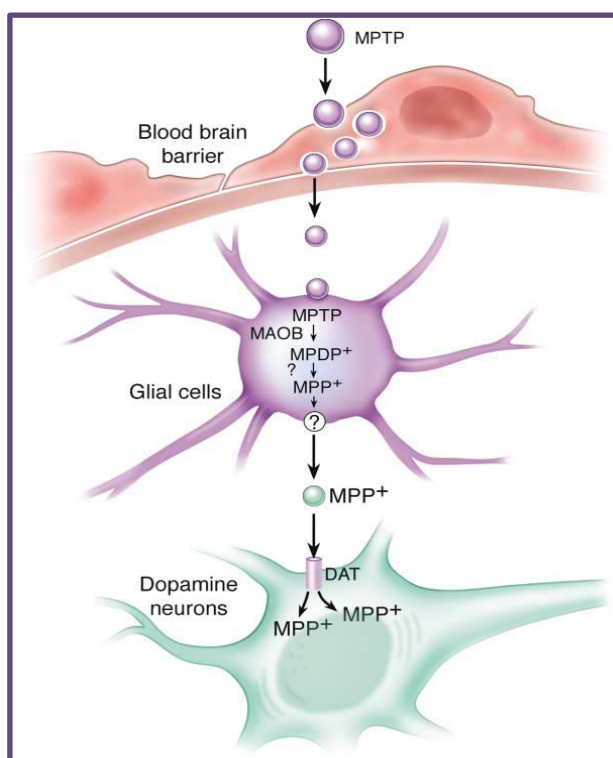

Fig. 1- Schematic MPTP metabolism in the nigrostriatal system.

Studies have shown that MPP^+ can also directly inhibit complexes III (ubiquinol: ferrocyanochrome c oxidoreductase) and IV (ferrocyanochrome c: oxygen oxidoreductase or cytochrome c oxidase) of the electron transport chain (Mazzio and Soliman 2004). This leads to impairment of ATP production, elevated intracellular calcium levels, and free radical generation, thereby exhibiting dopaminergic neurotoxicity (Yokoyama et al. 2008). MPTP administration has been shown to be more efficient at killing dopamine neurons in mice than rats, despite greater MPP^+ formation and uptake in rat striatum (Guillot and Miller 2009).

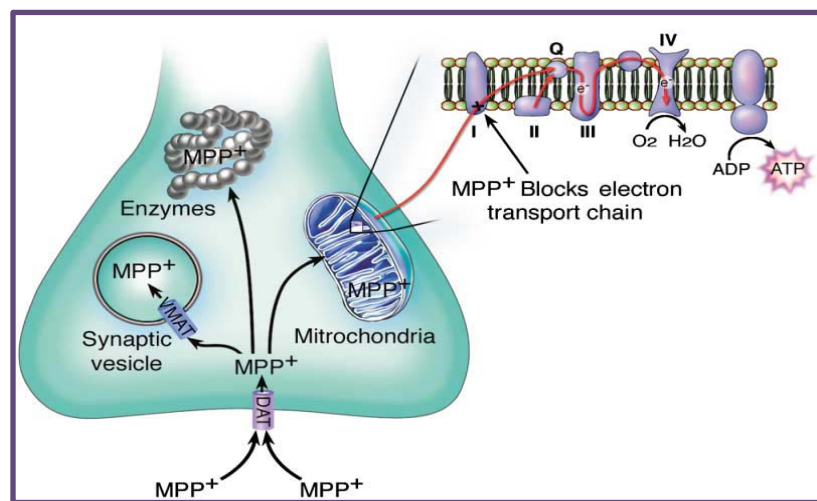

Fig. 2- Schematic representation of MPP^+ intracellular pathways.

Neuroprotective strategies against oxidative stress in PD

During the last few decades, there has been a remarkable progress in the understanding of the biology of PD, which has been translated into the development of numerous antiparkinsonian drugs. There are different therapeutic strategies for patients in an early stage versus patients in a late stage of the disease. The approach with dopamine precursor treatment in the form of L-dopa, represents the backbone of therapy. Although levodopa is considered the gold standard for treatment of PD, multiple complications such as motor fluctuations, hallucinations, and psychosis arise from long-term therapy (Olanow 2002; Jankovic 2002). For this reason, new neuroprotective strategies are needed and controlled clinical trials are focused on agents that combat excitotoxicity, counteract inflammation, provide trophic factors, inhibit apoptosis, reduce oxidative stress, and enhance mitochondria function (Ginsberg 2008). These new approaches include antiapoptotic drugs, pro-mitochondrial drugs and antioxidant drugs (Schapira 2008).

Antiapoptotic drugs: Apoptosis is considered to be an important cause of cell death in PD. The known genetic causes of PD and the toxins that induce dopaminergic cell death all mediate neuronal loss via apoptosis, although this may not be the only mechanism by which they act. Drugs that block apoptosis, therefore, seem to be good candidates for trials in PD. Selegiline, a selective irreversible MAO-B inhibitor, can protect cultured dopaminergic neurons against the MPP⁺ and in animal models can reduce dopaminergic cell loss in response to MPTP (Mytilineou and Cohen 1985; Wu et al. 2000). Selegiline also protects against apoptotic cell death induced by serum and growth factor withdrawal (Palhagen et al. 2006), possibly via an increased production of Bcl-2. Selegiline, by virtue of its MAO-B inhibitory activity will reduce the turnover of dopamine and so reduce free radical generation. Rasagiline is a more potent MAO-B inhibitor than selegiline and has also demonstrated protective effects against a wide range of neurotoxins both in vitro and in vivo studies. For instance, it protects against MPTP/MPP⁺ and 6-hydroxydopamine (6-OHDA) toxicity and excitotoxic-mediated damage, and stabilizes the mitochondrial membrane potential to reduce apoptotic cell death (Akao et al. 2002; Bar et al. 2004). Rasagiline has an advantage over selegiline in that both the parent compound and the aminoindan metabolite have neuroprotective actions, while selegiline-mediated neuroprotection appears to depend on its desmethyl

metabolite. Furthermore, selegiline is metabolized to metamphetamine, a compound which itself has neurotoxic effects and which also blocks the protective action of rasagiline, aminoindan and selegiline. The isomer of rasagiline devoid of MAO-B inhibitory activity is also active in laboratory neuroprotective studies, indicating that this property is independent of MAO-B inhibition (Youdim et al. 2001). Another antiapoptotic drug is the TCH346 that incorporates a propargyl ring within its molecular structure and so resembles selegiline. However, as it does not inhibit MAO-B, it was not anticipated to have symptomatic effects in clinical trials. Like other propargylamines (Schapira et al. 2005), TCH346 has been shown to prevent death of dopamine neurons in various in vitro models of apoptosis (Carlile et al. 2000; Waldmeier et al. 2000) and to protect against behavioural abnormalities and neurodegeneration in animal models of PD; in fact, TCH346 has been shown to prevent the stress-induced translocation of the glycolytic enzyme glyceraldehyde 3-phosphate dehydrogenase (GAPDH) from the cytoplasm to the nucleus where it promotes nerve cell death by blocking the transcriptional upregulation of protective molecules such as Bcl-2 and SOD (Carlile et al. 2000; Tatton et al. 2002).

Promitochondrial drugs: The recognition that mitochondrial dysfunction plays a role in PD pathogenesis provided a rationale to test the hypothesis that drugs that improve mitochondrial function might slow the progression of the disease (Schapira 2007). The first of these studies used coenzyme Q10 (CoQ10) which functions as both a component of the respiratory chain in shuttling electrons between complexes I and III, and as an antioxidant. Creatine is another treatment investigated for potential disease-modifying effect based upon the evidence for mitochondrial dysfunction in PD. Creatine is converted to phosphocreatine and can transfer a phosphoryl group to ADP to synthesize ATP and so enhance energy production. Creatine can reduce dopaminergic cell loss in the MPTP rodent model of PD (Matthews et al. 1999). One key set of genes dysfunctional in the brains of Parkinson's patients is controlled by the master switch PGC-1 α . PGC-1 α activates mitochondrial genes, including many of those needed to maintain and repair the power plants in the mitochondria. Reduced expression of the genes that PGC-1 α regulates likely occurs during the initial stages of PD, perhaps even before the onset of symptoms. The researchers then showed that PGC-1 α can be used as a "power switch" to turn on the expression of the energy genes-which are deactivated in patients with Parkinson's - in cell models of the disease (Zheng et al. 2010).

Antioxidant drugs: Dopamine agonists have a hydroxylated benzyl ring structure and so may have natural activity as free radical scavengers. Several dopamine agonists have demonstrated antioxidant activity in different in vitro systems. For instance, apomorphine scavenges free radicals from isolated rat brain mitochondria (Gassen et al. 1996) and can also reduce iron (Ubeda et al. 1993). Bromocriptine protects mice against 6-OHDA and MPTP-induced cell loss and attenuates dopamine depletion in mouse striatum in response to methamphetamine (Ogawa et al. 1994). Cabergoline decreased lipid peroxidation in rat striatum (Finotti et al. 2000) and also protected against 6-OHDA toxicity in mice (Yoshioka et al. 2002). Pramipexole and pergolide scavenge hydroxyl superoxide and nitric oxide radicals (Gomez-Vargas et al. 1998) and pergolide upregulates SOD in basal ganglia (Clow et al. 1993). Ropinirole increases the concentration of glutathione, catalase and SOD (Iida et al. 1999). Although there is good evidence that agonists may function as free radical scavengers, the concentration required for them to have this activity is probably higher than levels that might be achieved by oral administration.

Recently, we have been examining the neuroprotective effects of flavonoids which are powerful antioxidants, able to chelate metal ions as iron and have been shown in-vitro to boost cellular anti-oxidant levels. Although flavonoids are present in our diet, they are generally found in the parts of fruits that we throw away like the pith, peel and the core. Hence, flavonoids seem ideal agents to test as neuroprotective agents in PD (Soobrattee et al. 2005). Studies indicate that moderate amounts of wine, rich in polyphenolic compounds, can prevent the formation of free radicals, and then be used in the treatment of neurological diseases as Parkinson (Arvanitoyannis and Giakoundis 2006).

Antioxidative effects of RSV against oxidative stress

Increasing number of in vitro and in vivo studies demonstrated the efficacy of polyphenolic antioxidants to reduce or to block neuronal death occurring in the pathophysiology of some neurodegenerative disorders (Ramassamy 2006). Polyphenols are natural substances that are present in plants, fruits, and vegetables, including olive oil, red wine, and tea. Tea polyphenols have been found to be potent scavengers of singlet oxygen, superoxide anions, hydroxyl radicals and peroxy radicals (Morel et al. 1993; Nanjo et al. 1996) and consumption of tea has beneficial role in reducing risk of PD (Checkoway et al. 2002). Among polyphenolic compounds, numerous phytoalexins have been tested for their putative therapeutic functions either in vitro and in vivo experimental models and particular accumulating number of evidence suggests that RSV might possess a clinical usefulness (Pezzuto 2004).

RSV has been classified as a phytoalexin with a stilbene structure (fig. 3), for being synthesized in spermatophytes in response to injury, UV irradiation, and fungal attack (Ignatowicz and Baer-Dubowska 2001). It is present in a wide variety of dietary sources including grapes, plums and peanuts, but also in wines, especially red wines and to a much lesser extent in white wines. RSV is a phytoestrogen with striking similarity to the synthetic estrogen diethylstilbestrol, and available data suggests that RSV may be an estrogen receptors (ERs) agonist (Gehm et al. 1997) that bind to both ER α - and ER β (Bowers et al. 2000; Mueller et al. 2004; Robb and Stuart 2011; Wu et al. 2008). RSV exists as cis- and trans-isomers. Trans-RSV is the preferred steric form and is relatively stable if it is protected from high pH and light. One of the biological activities that has been ascribed to RSV involves its antioxidant potential (fig. 4). The ability of the polyphenolic compounds to act as antioxidants depends on the redox properties of their phenolic hydroxy groups and the potential for electron delocalization across the chemical structure (Martin et al. 2006).

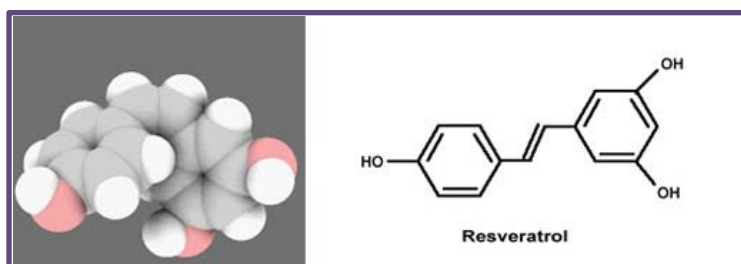

Fig. 3- Chemical structure of RSV.

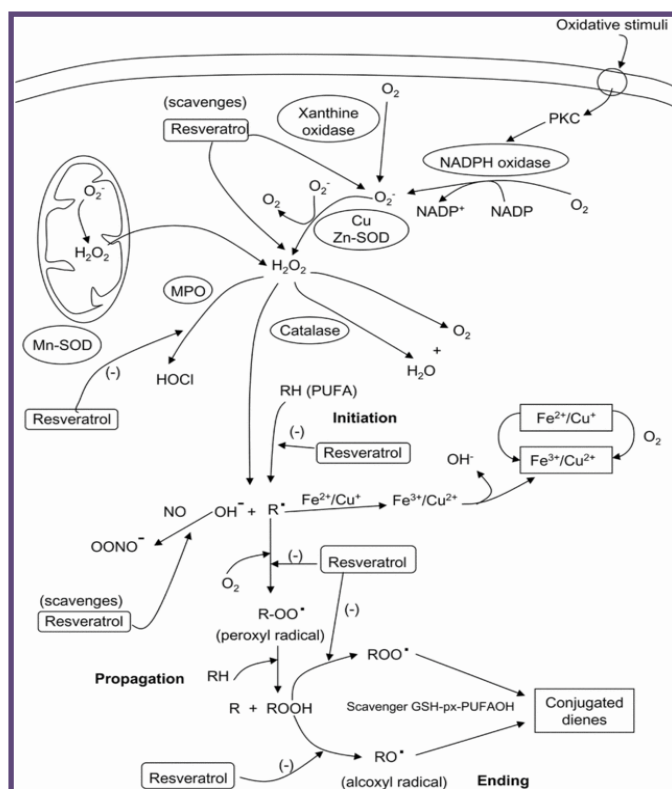

Fig. 4- Intracellular oxidative stress and potential antioxidant action sites of RSV.

The common recognition of RSV as a natural antioxidant was clarified by Zini et al. (Zini et al. 1999), who suggested three different antioxidant mechanisms: (i) competition with coenzyme Q and, to decrease the oxidative chain complex, the site of ROS generation; (ii) scavenging $O_2^{\cdot-}$ radicals formed in the mitochondria; (iii) inhibition of lipid peroxidation. According, numerous studies have demonstrated the ability of RSV to scavenge both $O_2^{\cdot-}$ and $\cdot OH$ radicals (fig. 4) (Leonard et al. 2003;Losa 2003;Martinez and Moreno 2000). However, RSV is both a free radical scavenger and a potent antioxidant because of its ability to promote the activities of a variety of antioxidant enzymes. In this context, RSV can increase the amounts of several antioxidant enzymes, including glutathione peroxidase, glutathione S-transferase and glutathione reductase (Yen et al. 2003).

Recent studies seem to support also pro-oxidant activities of RSV, depending on its concentration and the cell type. For example pro-oxidant action of RSV leading to oxidative breakage of cellular DNA has been proposed as action mechanism of its anticancer and apoptotic properties (de la Lastra and Villegas 2005). In a recent work the connection between RSV and oxidative stress in PC6.3 cells (a neuron-like cell line from the peripheral nervous system) has been investigated. Data showed that RSV at lower concentrations had a beneficial effect in PC6.3 cells, counteracting oxidative stress and increasing cell viability. Treatment with RSV increased levels of mitochondrial antioxidants and activated NF-kB signaling that may contribute to cell protection (Kairisalo et al. 2011).

Role of RSV in Neuroprotection and in Neurodegenerative diseases treatment

The natural phytochemical RSV has been considered for many years a potential anticancer drug, but recently it has come to the attention of neuroscientist too. Infact, RSV has neuroprotective features both in vitro and in vivo in models of AD, ischemic stroke, epilepsy, HD and PD (Albani et al. 2010). The AMP-activated protein kinase (AMPK), sirtuin 1 (SIRT1), and PGC-1 α were all thought to be involved in the etiology of these neurological disorders. Based on evidence that RSV modulates these proteins, it was proposed that RSV has therapeutic potential in the above-mentioned neurodegenerative disease (Canto and Auwerx 2009;Um et al. 2010;Vingtdeux et al.

2010). SIRT1 appears to be required for RSV metabolic functions in vivo by contributing to an energy sensing network involving AMPK and PGC-1 α (Canto and Auwerx 2009;Ruderman et al. 2010).

Consistent observations have demonstrated that moderate red wine consumption beneficially modulates AD-type cognitive deterioration in the Tg2576 transgenic mouse model of AD by attenuating A β neuropathology (Wang et al. 2006;Ho et al. 2009). Importantly, Kim and colleagues (Kim et al. 2007) recently reported that intracerebroventricular injection of RSV reduced neurodegeneration in the hippocampus and prevented learning impairment in the p25 transgenic AD mouse model by a mechanism that may involve a decrease in the acetylation of known SIRT1 substrates, for example, PGC-1 α and p53. The scientists have been exploring the ability of RSV to provide neuroprotection against ischemic attack. A recent study revealed that RSV, selectively induces heme oxygenase 1 (HO1) in a dose- and time-dependent manner in cultured mouse cortical neuronal cells and provides neuroprotection from free-radical or excitotoxicity damage. These data suggest a potential intracellular pathway by which RSV can provide cell/organ resistance against neuropathological conditions in ischemic stroke (Sakata et al. 2010). Moreover, laboratory animals given intraperitoneal injections of RSV showed less motor impairment and significantly smaller infarct volume, together with decreased delayed neuronal cell death and glial cell activation after ischemia (Raval et al. 2008). There are also some clear evidences that RSV decreased the frequency of spontaneous seizures and inhibited the epileptiform discharges. Moreover, RSV could protect neurons against kainate-induced neuronal cell death in CA1 and CA3a regions and depressed mossy fiber sprouting, which are general histological characteristics both in temporal lobe epilepsy patients and animal models (Wu et al. 2009). The authors showed the in vitro efficacy of RSV to protect against mutant polyglutamine-mediated cell death in striatal neuronal cultures isolated from the HdhQ111 knock-in mice model of HD (Parker et al. 2005). In addition, the authors also demonstrated RSV may neuroprotect HdhQ111 striatal neuron cultures through promotion of SIRT1-related mechanisms. Recent evidence suggests that PGC-1 α deregulation may be essential in the pathogenesis of HD (Chaturvedi et al. 2010;McGill and Beal 2006).

Based on this, together with in vitro evidence that RSV promotes SIRT-1 deacetylase activity (Howitz et al. 2003) and additional in vitro studies suggesting that RSV may protect against HD-type neurotoxicity. Previous in vivo studies suggest that

RSV exerts beneficial effects in experimental models of PD (Chao et al. 2008). For example, the administration of a diet containing RSV or treatment with RSV to adult mice prior to treatment with the neurotoxin MPTP exerts neuroprotective effects on dopaminergic neurons (Blanchet et al. 2008;Lu et al. 2008). Furthermore, RSV is known to protect neuronal cells against MPP⁺- induced oxidative stress and cellular death in vitro (Gelinas and Martinoli 2002;Okawara et al. 2007). Jin et al have showed that RSV treatment significantly counteracts SNc neuronal death in rats treated with 6-OHDA by reducing inflammatory reaction (Jin et al. 2008). Accordingly, RSV could be an interesting candidate for potential application in the treatment of PD; at present it remains to be clarified if RSV could activates SIRT1 and offers neuroprotection in PD (Pallas et al. 2009).

In some work has also been hypothesized that the neuroprotective effect of RSV in Parkinson's disease, may be linked to its ability to act as a phytoestrogen; infact, RSV can mimic the action of Ers agonist (Gehm et al. 1997;Bowers et al. 2000) and this has a correlation with the information that the PD is almost twice as common in men as in women (Shulman 2007). Therefore researchers have long hypothesized that sex hormones might play a role in the disease (Gelinas and Martinoli 2002;Pozzi et al. 2006). Infact, currently in the research community, there is much interest in the possibility of using estrogen to either slow the progression or reduce the risk of PD (Shulman 2007).

PGC-1 α play an important role in Neurodegenerative diseases

Recent studies indicate that maintenance of mitochondrial function is beneficial in the prevention or delay of neurodegenerative diseases. A central molecule seems to be the PGC-1 α , which is the key regulator of mitochondrial biogenesis and oxidative metabolism (Lin et al. 2004;Tynismaa et al. 2010). The transcriptional coactivator PPARGC1A (PGC-1 α) gene is located on chromosome 5 in mice (chromosome 4 in humans) and encodes a protein containing 797 (mouse) or 798 (human) amino acids (Puigserver et al. 1998). PGC-1 α belongs to a small family of transcriptional coactivators, including PGC-1 β and PGC-1-related coactivator (PRC), which possess a common function in mitochondrial physiology, in addition to control over separate

specific biological programs. PGC-1 α was the first member identified as a cofactor for the nuclear hormone receptor PPAR γ that is required for the adaptive thermogenic response to lower temperatures (Puigserver et al. 1998; Puigserver et al. 1999).

PGC-1 α as a transcriptional coactivator functions through direct physical interaction with transcription factors directly bound to DNA promoter regions. Structural and functional studies have indicated that PGC-1 α has a strong transcriptional activation domain at the N-terminus, which interacts with several histone acetyltransferase complexes including 3'-5'-cyclic adenosine monophosphate (cAMP) response element-binding protein (CREB)-binding protein, p300, and steroid receptor coactivator-1 (fig. 5) (Puigserver et al. 1999). These proteins acetylate histones and remodel chromatin structure into a state that is permissive for transcriptional activation. Adjacent to the N-terminal domain is a regulatory region that roughly spans 200 amino acids. Toward the C-terminus, PGC-1 α recruits the thyroid receptor-associated protein/vitamin D receptor interacting protein/mediator complex that facilitates direct interaction with the transcription initiation machinery (Wallberg et al. 2003). The Ser/Arg-rich domain and an RNA-binding domain toward C-terminus have been demonstrated to couple pre-mRNA splicing with transcription (fig. 5) (Monsalve et al. 2000).

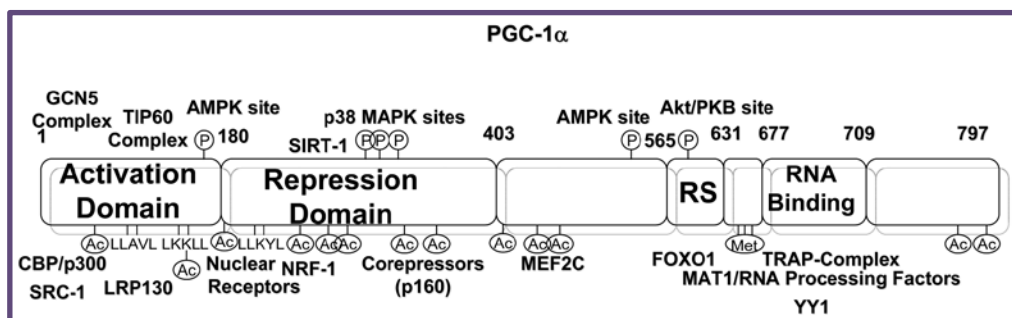

Fig. 5- Architecture of the PGC-1 α transcriptional coactivator. PGC-1 α contains several functional domains that correlate with the interactions with different proteins and complexes.

As such, PGC-1 α serves as a platform for the recruitment and assembly of various chromatin remodeling and histone-modifying enzymes to alter local chromatin state. Importantly, the PGC-1 α transcriptional activator complex is also able to displace repressor proteins, such as histone deacetylase and small heterodimer partner, on its target promoters, providing an alternative mechanism for gene activation (Borgius et al. 2002). PGC-1 α and PGC-1 β share extensive domain similarity and several clusters of conserved amino acids, such as the LXXLL motif that interacts with nuclear receptors and host cell factor 1 interacting motif (Lin et al. 2003). The third family member, PRC, also contains the activation domain and RNA-binding domain, but overall has more limited homology to PGC-1 α and PGC-1 β (Andersson and Scarpulla 2001). PGC-1 α contains specific phosphorylated, acetylated and methylated amino acids which can modulate its activity as well as interaction with other proteins including corepressors (Lerin et al. 2006). An important regulatory mechanism of PGC-1 α is through SIRT1-mediated lysine de-acetylation. Moreover, SIRT-1 activation will maintain PGC-1 α in a deacetylated active form bound to the chromatin and increasing rates of transcription (Rodgers et al. 2005;Gerhart-Hines et al. 2007).

PGC-1 α is abundantly expressed in tissues with high energy demand, including the brown adipose tissue (BAT), heart, skeletal muscle, kidney, liver and brain (fig. 6) (Wu et al. 1999;Knutti et al. 2000). Infact, when ectopically expressed in fat or muscle cells, PGC-1 α strongly stimulates the program of nuclear and mitochondrial-encoded mitochondrial genes as well as organelle biogenesis (Wu et al. 1999). The stimulatory effects of PGC-1 α on mitochondrial genes are achieved through its coactivation of nuclear respiratory factors 1 and 2 (NRF1 and NRF2, respectively) and the estrogen-related receptor α (ERR α) (fig. 6) (Mootha et al. 2004;Schreiber et al. 2004).

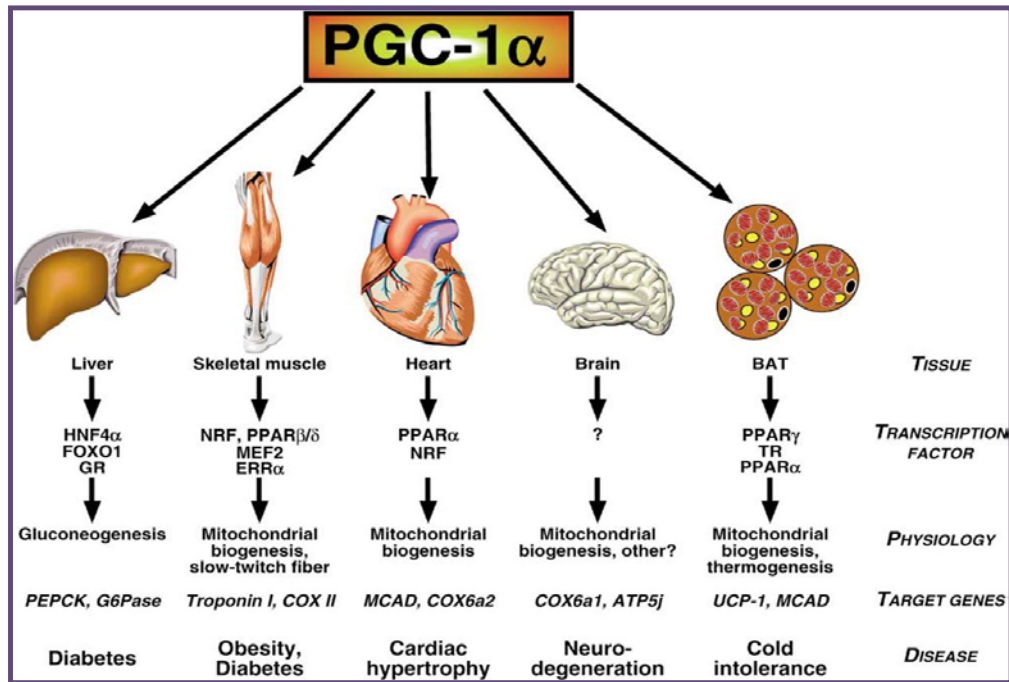

Fig. 6- Schematic representation of the different functions of PGC-1 α in its target tissues.

The induction of NRF1 and NRF2 subsequently leads to the increased expression of mitochondrial transcription factor A (mtTFA) (Wu et al. 1999) as well as other mitochondrial subunits of the electron transport chain complex such as ATP synthase, cytochrome c, and COXIV (Scarpulla 2002a; Scarpulla 2002b). mtTFA translocates to mitochondrial matrix, where it stimulates mitochondrial DNA replication and mitochondrial gene expression (Larsson et al. 1998). The brain constitutes perhaps the most vulnerable tissue to oxidative stress. Impaired PGC-1 α expression and mitochondrial function contributes to neurodegeneration in susceptible neurons (Weydt et al. 2006). In addition, PGC-1 α plays an important role in the regulation of genes responsible for the detoxification of ROS, including copper/zinc SOD1, manganese SOD2, and glutathione peroxidase 1 (St-Pierre et al. 2006). Interestingly, SIRT-1 plays a similar role in oxidative stress function in combination with FoxO transcription factors (Brunet et al. 2004). For this reason, PGC-1 α plays an important role in normal brain function and a major role in the oxidative stress response (St-Pierre et al. 2006).

In mice, PGC-1 α deficiency causes behavioral changes including anxiety and hyperactivity as well as hind limb claspings. These behavioral changes are associated with spongiform-like vacuolization primarily in the striatum associated with gliosis and leads to reduced expression of several brain-specific genes that are all associated with

normal brain function (Lin et al. 2004). SN and CA1 neurons are more susceptible to neurodegeneration in response to neurotoxins suggesting an important role of PGC-1 α in neuronal maintenance (Lin et al. 2004). PGC-1 α also seems to be involved in the control of neurite growth and neuronal synaptic function (Cowell et al. 2009). PGC-1 α has been implicated in the onset and progression of neurodegenerative diseases. Postmortem brain samples of patients with HD had a decreased level of PGC-1 α mRNA (Cui et al. 2006;Weydt et al. 2006). PGC-1 α is repressed by a mutant form of the Huntington protein which leads to mitochondrial dysfunction and neurodegeneration. Over-expression of PGC-1 α rescues cells from the deleterious effect of HD, whereas loss of PGC-1 α in HD mice aggravated neurodegeneration (Cui et al. 2006). Moreover, PGC-1 α KO mice show HD like phenotype and neuronal lesions suggesting that PGC-1 α is crucial for maintenance of striatal function. Additionally, PGC-1 α SNPs are associated with the age of onset of HD. Polymorphisms are also associated with the onset of AD (Qin et al. 2009). In a PD mouse model, PGC-1 α deficiency caused an increased degeneration of dopaminergic neurons in the SN associated with oxidative damage (St-Pierre et al. 2006;Bender et al. 2006).

Interestingly, activators of PGC-1 α such as RSV have a neuroprotective effect in acute and chronic brain injury as well as in neurodegenerative diseases suggesting a role for PGC-1 α in modulating the outcome of the disease (Sun et al. 2010). In addition, studies with mice treated with RSV and ectopic expression of SIRT1 (that correlated with deacetylation of PGC-1 α) in the hippocampus further support the neuroprotective role of SIRT1 in AD and ALS (Kim et al. 2007). Together, these studies suggest that PGC-1 α and SIRT1 might be potential targets to treat neurodegenerative diseases.

Aims

Aim 1

The aim 1 of present work was to study the neuroprotective effect of RSV against oxidative stress using both in vivo and in vitro models. To this end, we evaluated neuroprotective effects of RSV in MPTP-mouse model of PD, inducing death of dopaminergic neurons in the SN and in dopaminergic neuronal cell lines SN4741 exposed to oxidative stress. Additionally, in order to identify the possible “neuroprotective signaling” involved in the effect of RSV, the investigation was also extent to evaluation of RSV effect on expression of SOD2 and Trx2 and on the activity and the levels of transcriptional coactivator PGC-1 α that is a master regulator of cell metabolism, mitochondrial biogenesis, oxidative stress and gene expression.

Aim 2

The aim 2 of present work was to explore the neuroprotective role of PGC-1 α in MPTP mouse model of PD, using transgenic mice overexpressing PGC-1 α (PGC1-tg).

Materials and methods

Animals

Adult male and female C57/BL6 mice (25-28 g b.w.) from local stock have been used for the present study. The mice were kept under environmentally controlled conditions, ambient temperature 24°C, humidity 40% and 12-h light/dark cycle with food and water ad libitum. Procedures involving animals and their care were conducted in conformity with the institutional guidelines that are in compliance with national (D.L. n. 116,G.U., suppl. 40, 18 Feb. 1992) and international laws and policies (EEC Council Directive 86/609, OJ L 358,1, Dec. 12,1987; NIH Guide for the Care and Use of Laboratory Animals, NIH Publication no. 80-23, 1985 and Guidelines for the Use of Animals in Biomedical Research, *Thromb. Haemost.* 58, 1078–1084,1987). All efforts were made to minimize the number of animals used and their suffering and all experiments were approved by the local ethical committee.

Generation of PGC-1 α transgenic mice

The PGC-1 α cDNA with a Flag-tag was cloned into the Thy 1.2 expression cassette that drives transgene expression in brain neurons (Caroni 1997;Trapp et al. 2003). Transgenic mice were generated using standard techniques at the Uppsala Transgenic Facility, at Uppsala University, Sweden. The genetic background of the mice was CBA \times C57BL/6 and they were backcrossed to C57BL/6 mice for several generations to produce stable PGC-1 α transgenic mouse lines, and controls were from the same breeding. The levels of PGC-1 α in brain tissue including SN and striatum were studied by immunoblotting and using a polyclonal anti-PGC-1 α antibody raised in rabbit against the amino acids 221–234 in the mouse sequence. Immunoblots were done as described below.

To analyze the transgenic expression of PGC1 in dopaminergic neurons, immunostaining in SN was done using anti-Flag antibodies (1:300; Cell Signaling) in combination with anti-TH antibodies and employing appropriate fluorescent-labeled secondary antibodies. The mice showed expression of the PGC-1 α transgene in dopaminergic neurons. Apart from midbrain, the transgene was expressed in other brain regions (data not shown), and a thorough characterization of gene expression in the PGC-1 α transgenic mice will be reported later.

Drug treatments

All experiments were approved by the local ethical committee and performed in accordance with the European Communities Council Directive (86/609/EEC). Mice received three intraperitoneal (i.p.) injections of 14 mg/kg MPTP (Fluka Biochemica) within a time period of 3 h followed by a fourth injection using 7 mg/kg MPTP. This protocol induced a lesion of TH-positive neurons in the SNc with a low degree of mortality of animals. Twenty mg/kg RSV (R5010 Sigma) was dissolved in 50% DMSO/70% ethanol and diluted in saline until to a final volume of 0.2 ml per mice and given i.p. Control mice received vehicle 50% (DMSO/70% ethanol diluted in saline) only. All mice were killed 7 days after the MPTP treatment using deep anesthesia and their brains were collected for immunohistochemistry or Western-blot analysis.

To verify the involvement of estrogen receptors on RSV-enhanced DAT expression, groups of mice were treated with the antiestrogen ICI 182,780 also known as Fulvestrant (Tocris Bioscience, Bristol, UK; cat. no. 1047). ICI 182,780 was used at dose of 2 mg/kg b.w., and was dissolved first in absolute ethanol and thereafter diluted in sesame oil and injected subcutaneously in 50 μ l. Mice were treated with RSV or antiestrogens according to injection scheme described in results section. Control mice received an equal volume of vehicle. Mice were killed under deep anesthesia.

Immunohistochemistry

Cell counting and measurements of fiber densities as described below were all carried out in a double-blind manner. To compare experimental groups, the sections from control and treated animals were processed at the same time and under the same conditions. Collected brains were fixed with 4% paraformaldehyde in 0.1 M phosphate buffer (pH 7.4) for 3 days, immersed in a 10% sucrose solution for 1 day and in 20% sucrose for a further day and subsequently frozen in cooled isopentane and 20- μ m-thick coronal sections were prepared on a cryostat (Micron, HM 500 M, Walldorf, Germany) for striatum and SN as following described. Striatum sections were prepared from A 4.70 mm to A 5.70 mm, according to the mouse atlas. For each striatum were collected 15 sections by systematic sampling every third section. Five control sections were selected to determine optical background of TH and DAT immunostaining for fiber density analysis. We analyzed the entire SN from bregma level A2.54 to A4. Coronal sections were made and examined for TH-positive cell count were sampled every two sections. In the SNc, cell number was determined by using TH and neuron-specific DNA-binding protein (NeuN) immunostaining. These two methods were used to explore whether the loss of cells after MPTP treatment was due to loss of antigen expression (TH) or to a loss of the cells themselves (NeuN). For TH, DAT and NeuN immunostaining floating brain sections were used. Following a washing for 5 min in PBS, the sections were preincubated for 30 min in blocking buffer consisting of 2.5% normal goat serum and 0.3% Triton X-100 and 0.3% hydrogen peroxidase, then washed two times. Sections were subsequently incubated overnight at 4°C in PBS/0.3% Triton-X-100 in the presence of the primary antibody and 1.5% blocking serum. The following antibodies and dilutions were used: mouse polyclonal anti-TH and monoclonal anti-NeuN antibodies diluted 1:1,000 and 1:300, respectively (AB152 and MAB377 Chemicon, Temecula, CA, USA); rat monoclonal anti-DAT antibodies diluted 1:200 (SC32258 Santa Cruz Biotech, CA, USA). Control sections were processed without primary antibodies in order to determine optical background of TH and DAT immunostaining. After three 5-min washings with PBS, the sections were incubated for 1 h with a horseradish peroxidase–streptavidin complex (Vector, Burlingame, CA), diluted 1:100 in PBS. After one washing in PBS and one in Tris–HCl buffer (0.1 M pH 7.4), the peroxidase reaction was developed in the same buffer containing 0.05% 3,3-diaminobenzidine-4 HCl and 0.003% hydrogen peroxide. The sections were dehydrated

and covered with Entellan. The quantification of fibers densities in striatum was performed using ImageJ software (<http://rsb.info.nih.gov/ij/>). The number of TH-positive DA neurons of SNc was counted using stereology procedures as described (Aguirre et al. 2008). Every mounted section was numbered following the rostrocaudal level corresponding to the mouse brain atlas. The total number of cells in different groups was estimated by means of the optical fractionator, which combines the optical dissector with the fractionator-sampling scheme. Volume fraction estimations for TH-positive neurons were computed by applying the Cavalieri method based on point counts obtained during the application of the optical fractionator. An Olympus BH2 microscope (Olympus, Denmark) was interfaced with a computer (DGC systems, Stockholm, Sweden) and a color video camera (CCD-iris, Sony, Japan). The CAST-Grid software package (Olympus, Glostrup, Denmark) generated sampling frames with a known area and directed the motorized X–Y stage (Lang, Huttenberg, Germany), and a microcator (MT12, Heidenheim, Germany), which monitored the movements in the Z-axis with a resolution of 0.5 μm . Both sides of the SNc were defined using a 4 \times objective. After having counted the objects (ΣQ^-), the total number of cells in the nigral region was then estimated as: $n = \Sigma fs \cdot fa \cdot fh$, where fs is the numerical fraction of the section used and considered in the present analysis as $fs = 2$ since the SN sections examined were sampled every two sections, fa is the areal fraction and fh is the linear fraction of section thickness. The coefficient of error (CE) for each estimation and animal ranged from 0.03 to 0.09. The total CE of each group ranged from 0.02 to 0.06.

Preparation and immunoblotting of different brain regions

SN and striatum from brains of different experimental groups were dissected under stereomicroscopy and frozen in cooled isopentane. The SN was dissected as follows: a thick brain coronal section at SN level (A 0,500; A 1,700), according to mouse atlas was made using a brain slicer and on this section SN corresponding area, including SNc and SNr, was dissected under stereomicroscopy and used for WB analysis by pooling left and right SN. Striatum and SN tissue pieces were homogenized in cold buffer containing 50 mM Tris HCl pH 7.5, 100 mM NaCl, 1 mM DTT, 5% NP-40, 10 $\mu\text{g}/\text{ml}$ aprotinin, 10 $\mu\text{g}/\text{ml}$ leupeptin, 0.1 mM phenylmethylsulfonyl fluoride, 100 μM sodium orthovanadate (Na_3VO_4) and 1 mM EDTA (Sigma-Aldrich, St. Louis, MO, USA). The homogenate was

left on ice for 30 min and centrifuged at $10,000 \times g$ for 15 min at 4°C to yield supernatant fractions that were stored at -80°C until use. To obtain enough material, the two SN were pooled from one animals and run together whereas individual striatum was analyzed separately. Using SDS-PAGE, 30–40 μg of protein was separated, transferred to nitrocellulose membranes (Hybond-C Extra, Amersham), blocked for 1 h in TBST and 5% skim milk, and incubated overnight at 4°C with primary antibodies, including anti-DAT, anti- TH (1:2,000), anti-SOD2 (1:5,000; Abfrontier, Seoul, Korea) and anti-COX IV (diluted 1:5,000, Abcam) antibodies. After washing, the membrane was incubated for 1 h at room temperature with peroxidase-conjugated secondary antibodies (diluted 1:5,000) and bands were visualized by enhanced chemiluminescence (Amersham ECL). β -actin (SC47778 Santa Cruz Biotech, CA, USA 1:6,000) was used as loading control. Quantification was performed using ImageJ software (<http://rsb.info.nih.gov/ij/>).

Cell cultures and immunoblotting

The SN4741 dopaminergic cell line derived from mouse SN (Son et al. 1999) was cultured in Dulbecco's modified Eagle's medium/2% fetal calf serum to about 80% confluence. Cells were incubated in 96-well Costar plates and treated with different concentrations of 1-methyl-4-phenyl pyridinium (MPP^+ , Sigma) in the absence or presence of 5–10 μM RSV. Cell viability was determined using the 3-(4,5-dimethylthiazol-2-yl)-2,5-diphenyl tetrazolium bromide (Sigma) assay as described (Korhonen et al. 2001; Sokka et al. 2007). Immunoblots were done as described (Kairisalo et al. 2009; Reijonen et al. 2010) using the following primary antibodies: anti-DAT antibodies diluted 1:200 (SC32258 Santa Cruz Biotech, CA, USA), SIRT1 (1:2000; Abcam, Cambridge, UK), PGC-1 α (1:1000; Cell Signaling, Danvers, MA, USA), SOD1 (1:5,000; Santa Cruz Biotech), SOD2 (1:30,000; Abfrontier), Trx2 (1:1,000; Abfrontier), Catalase (1:500; Abcam), HO-1 (1:500; Stressgen, Ann Arbor, MI, USA), and XIAP (1:5,000; BD Biosciences, Franklin Lakes, NJ, USA). Appropriate peroxidase-conjugated antibodies (1:2,500, Jackson ImmunoResearch, Biofellow, Helsinki, Finland) were added for 1 h and detection was performed using Super Signal West Pico Substrate (Pierce). Quantification was performed using ImageJ software.

Immunoprecipitation of PGC-1 α

Lysates from control and RSV-treated SN4741 cells were incubated overnight at 4°C on a rotary shaker using 10 μ g/ml anti-PGC-1 α antibodies (Calbiochem, San Diego, CA, USA). Immune complexes were bound to Sepharose- A for 2 h at 4°C and recovered by centrifugation. Beads were washed three times and the samples resuspended in SDS PAGE buffer and subjected to immunoblotting using either anti-PGC-1 α antibodies (1:1,000; Cell Signaling) or anti-acetylated-lysine antibodies (1:1,000; Cell Signaling). The intensity of the bands reveals the degree of acetylation of PGC-1 α under different conditions.

Transfection and promotor assays

SN4741 cells in six-well plates were transfected for 24 h with 0.5 μ g of PGC-1 α promoter constructs linked to luciferase reporter (St-Pierre et al. 2006) using the Transfectin reagent followed by treatment with 5–10 μ M RSV for 24 h. To control for transfection efficiency, 0.02 μ g Renilla luciferase pRL-TK was used. Cells were harvested after 48 h using Passive Lysis Buffer, and the Renilla and the firefly luciferase activities were measured using a luminometer (Promega, Biofellow, Helsinki, Finland) (Kairisalo et al. 2009). Results are shown as fold increase in luciferase normalized to Renilla activity.

ROS measurements

Cells were treated for 24 h with MPTP or RSV. The levels of reactive oxidative species (ROS) were measured by loading cells for 15 min with 10 μ M dihydroethidium (Molecular Probes) followed by examination using fluorescence- activated cell sorter Aria (FACS; BD Biosciences) as described earlier (Reijonen et al. 2010;Kairisalo et al. 2007).

Quantitative RT-PCR

Total RNA was extracted from SN of wild-type and PGC1- tg mice using RNeasy tissue kit (QIAGEN) followed by cDNA synthesis. Sybergreen (Applied Biosystems) realtime quantitative PCR assays were performed on an ABI Prism 7000 Sequence Detector essentially as described (Hong et al. 2010). Results show averages of triplicate experiments normalized to GAPDH. Primer sequences were:

SOD2,

forward (Fw), 5'-GACCCATTGCAAGGAACAA-3'

and reverse (Rev), 5'-GTAGTAAGCGTGCTCCCACAC-3';

COX IV,

Fw, 5' TCACTGCGCTCGTTCTGAT -3'

and Rev, 5'-CGATC GAAAGTATGAGGGATG-3'.

High-pressure liquid chromatography (HPLC)

Dopamine (DA) and 3,4-dihydroxyphenylacetic acid (DOPAC) concentrations in mouse striatal tissue were determined essentially as described before (Airavaara et al. 2006). In brief, the frozen samples were homogenized in 0.5 ml of homogenization solution consisting of six parts of 0.2 M HClO₄ and one part of antioxidant solution containing oxalic acid in combination with acetic acid and L-cysteine. The homogenates were centrifuged at 20,800 × g for 35 min at 4°C. The supernatant was removed to 0.5 ml Vivaspin filter concentrators (10,000 MWCO PES; Vivascience AG, Hannover, Germany) and centrifuged at 8,600 × g at 4°C for 35 min. Filtrates containing monoamines were analyzed using high-pressure liquid chromatography with electrochemical detection.

Isolation of mitochondria and measurement of respiratory control

Mitochondria from wild-type and PGC1-tg mice were prepared essentially as described previously for rat liver mitochondria (Speer et al. 2003). In brief, brain tissue was excised and minced into pieces in isolation medium containing 10 mM Hepes-K pH 7.4, 1 mM EGTA, and sufficient sucrose to obtain an osmolarity of 300 mOsm. The brain pieces were homogenized and centrifugated at $800 \times g$ for 8 min, and the resulting supernatant centrifugated twice at $10,000 \times g$ for 10 min to obtain a mitochondrial pellet that was resuspended in 300 μ l of isolation medium. All steps were carried out at $+4^{\circ}\text{C}$ and mitochondria were used for measurements of membrane potential and respiration within 4 h. Mitochondrial respiration was measured using a Clarktype electrode (Yellow Springs Instruments, USA). Mitochondria were suspended in medium containing 125 mM KCl, 10 mM Hepes-K pH 7.4, 2 mM MgCl, 1 mM Pi, 100 μ M EGTA. Respiration was started by the addition of 10 mM malate plus 10 mM glutamate or 10 mM succinate. The respiratory control ratio was determined by the addition of aliquots of ADP. Mitochondrial membrane potential was measured with the fluorescent dye tetramethylrhodamine (TMRM) using a Cary Eclipse Fluorescence Spectrophotometer (Varian, USA) set to operate with excitation at 550 nm and emission at 575 nm. The measurement medium was supplemented with 0.5 μ M TMRM.

Quantitative evaluations and statistics

Quantification of fiber densities was performed using ImageJ software. Immunoblots were evaluated by one-way ANOVA with intergroup differences analyzed by Fisher's protected least significant difference (PLSD) test, corrected by Bonferroni's procedure for dependent samples. Statistics of cell viability were performed using Student's t test comparing two groups, and one-way ANOVA followed by Bonferroni's post hoc test when comparing three or more groups.

Results

Neuroprotective effects of RSV in dopaminergic neurons in vivo

MPTP lesion and neuroprotective effect of RSV treatment evaluated by optical count of dopaminergic neurons in the SNc

The first aim of the present work was to analyze the neuroprotective effect of RSV against MPTP-induced dopaminergic cell death in the mouse SNc. The MPTP and RSV treatment used, are shown in the scheme of figure 7A. In coronal brain sections, following immunohistochemical detection of dopaminergic neurons by tyrosine hydroxylase (TH) antibodies, was performed an optical count of TH-positive neurons in the SNc, in order to evaluate the neuroprotective effects of RSV treatment. Treatment with MPTP induced a 44% reduction in the number of dopaminergic neurons in the SNc compared with vehicle treated control mice (fig. 7B and 7C). However, co-treatment with 20mg/kg RSV restored the number of TH-positive cells to 83% of control (fig. 7B and 7C). The number of NeuN-stained cells in the SNc in the three experimental groups corresponded to the data obtained with TH immunostaining showing that RSV was largely neuroprotective after the MPTP insult (fig. 7D).

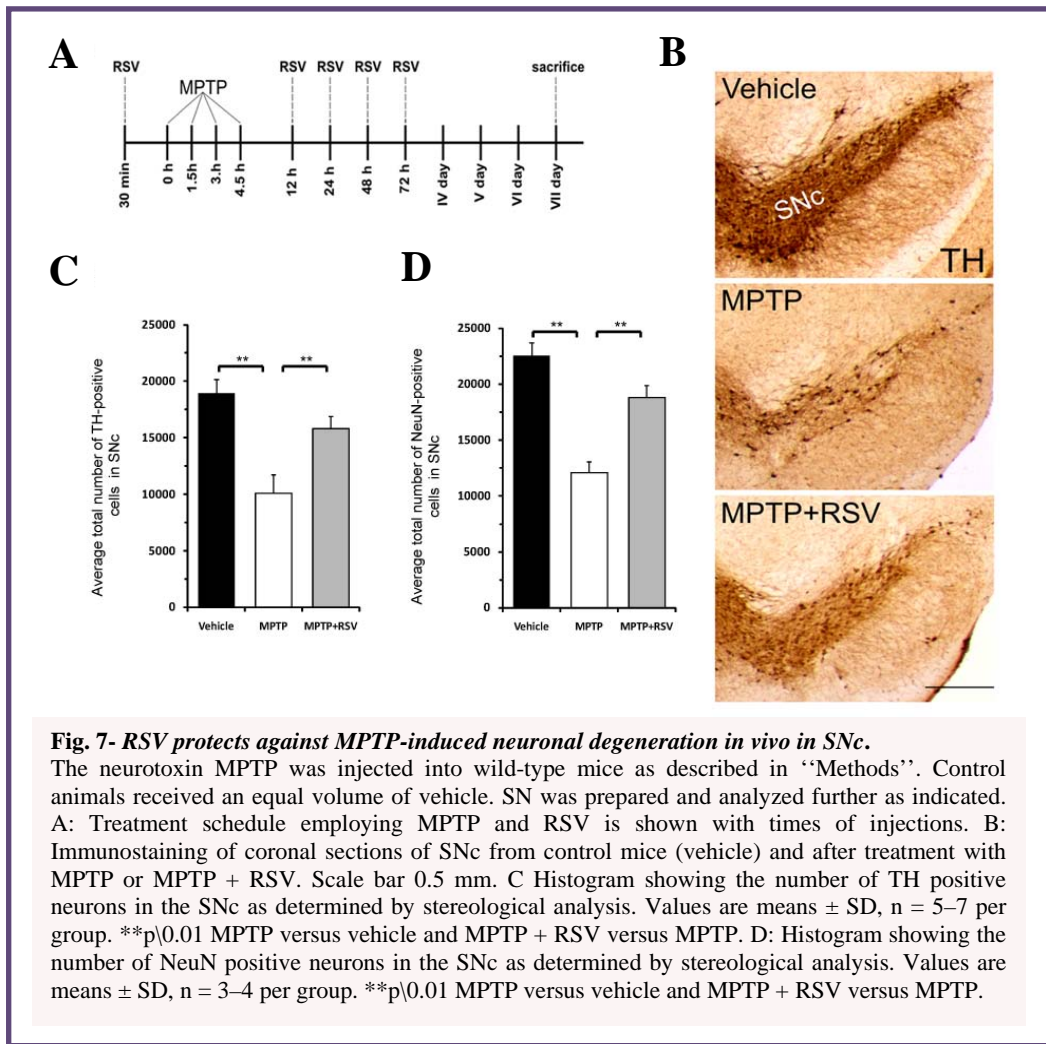

MPTP lesion and effects of RSV treatment on density of dopaminergic fibers in the striatum evaluated by western blotting and immunohistochemistry

In order to further evaluate the neuroprotective effects of RSV treatment we examined the density of dopaminergic fibers in the striatum by evaluating TH and DAT protein expression levels using western blotting procedure. MPTP treatment led to a dramatic reduction (about 63%) of TH protein expression levels in the striatum, as compared to control vehicle treated (fig. 8A), but the administration of RSV was able to restore the TH levels to 78% of the values observed in vehicle treated control (fig. 8A).

The levels of DAT were also reduced by MPTP treatment to about 25% of controls, and RSV also increased this value to about 75% of controls (fig 8B). In control mice, the administration of 20 mg/kg RSV alone changed neither the TH nor the DAT protein levels (fig. 8A and 8B). Immunohistochemistry combined with densitometry revealed a

significant preservation of TH- and DAT-positive fibers in the striatum of MPTP-treated mice after RSV administration (fig. 8C and 8D).

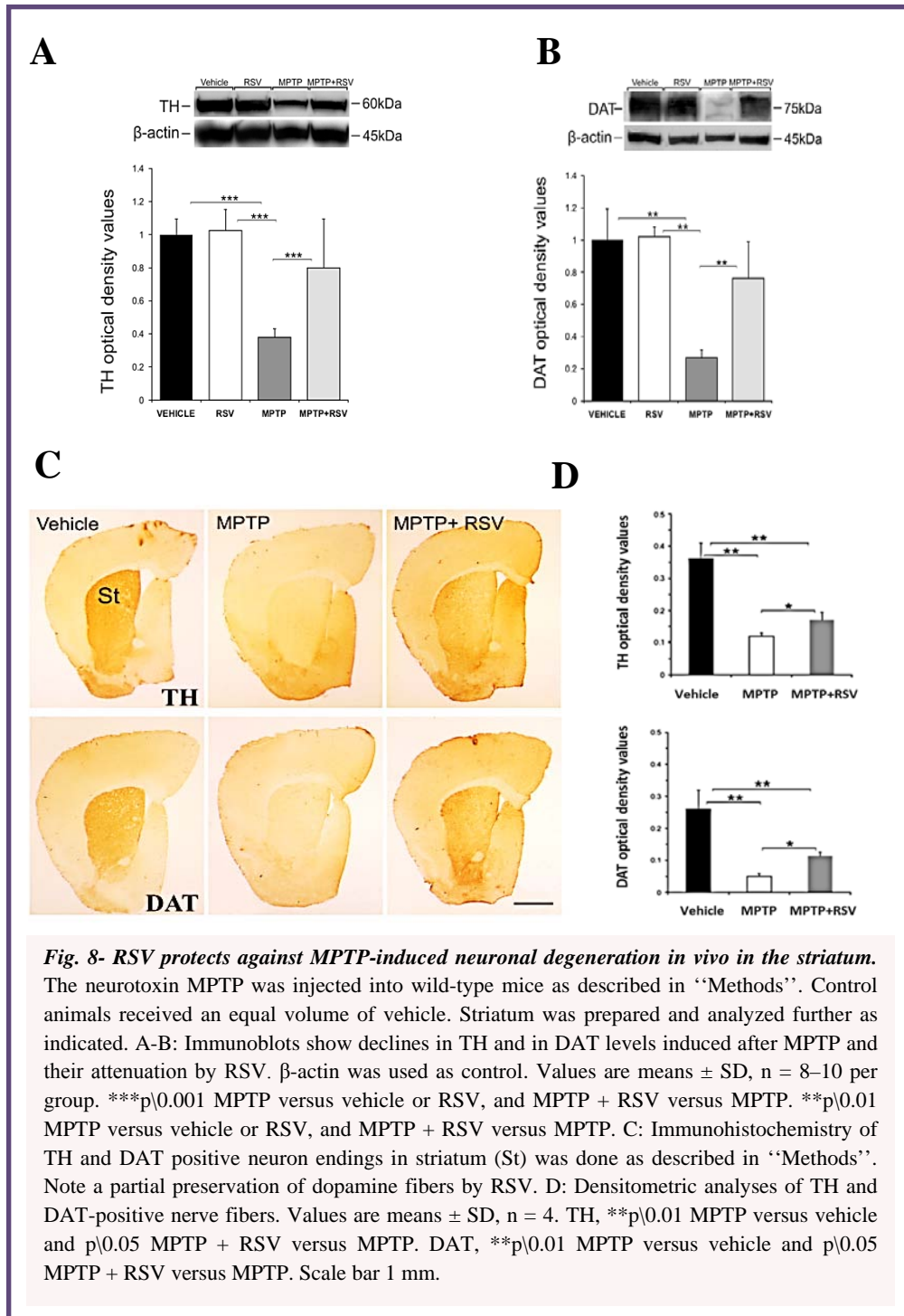

RSV treatment enhances antioxidant enzyme SOD2 levels in SN

Since RSV is both a free radical scavenger and a potent antioxidant because of its ability to promote the activities of a variety of antioxidant enzymes, we evaluated the levels of the antioxidant enzyme SOD2 both in the SN than in striatum using western blotting procedure. We observed that RSV increased the levels of SOD2 in the SN but not in striatum (fig. 9A and 9B).

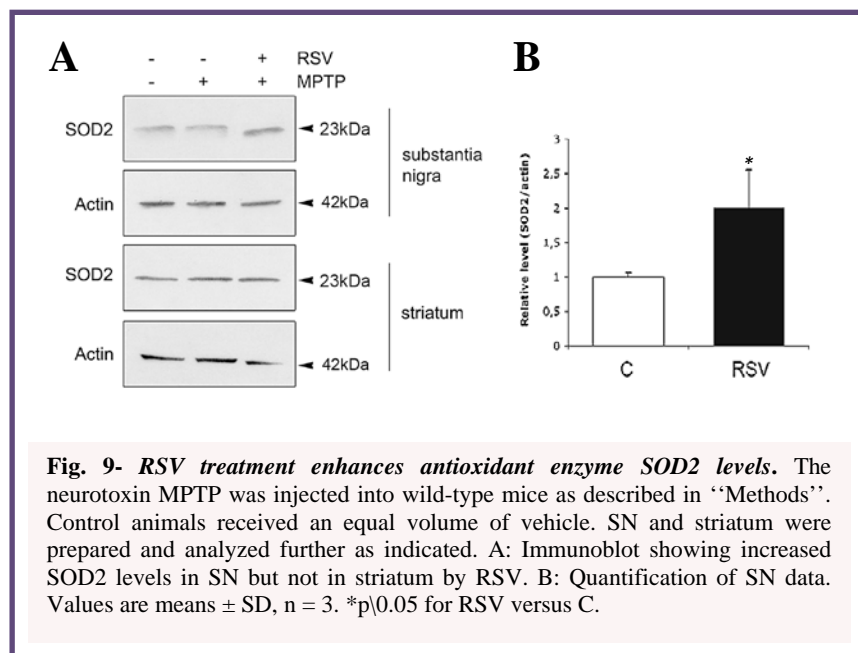

RSV treatment enhances DAT expression in the striatum of female mouse

The striking similarity of chemical structure of RSV to the synthetic estrogen diethylstilbestrol prompted us to consider the possibility that the extent of neuroprotective effects of RSV on MPTP model could be different in male mouse as compared to female mouse.

During these experiments was unexpectedly observed that in female mouse, but not in male mouse, RSV treatment may lead to a strong increase of dopamine transporter (DAT) in the striatum. We treated male and female mice with RSV using daily injections of RSV (20 mg/Kg i.p.) for four days and analyzing the brains eight days after the first injection of RSV (fig. 10A). Data showed that RSV significantly increased DAT protein levels in the striatum of female mice as compared to matched control (fig. 10B). This effect of RSV on DAT levels was also observed in the SN (data not shown). By contrast,

RSV was not able to increase DAT levels in the striatum of male mice (fig 10C). Comparing the basic DAT levels between males and females, we did not observe significant difference linked to sex (fig. 10D). A time-course study of RSV treatment in female mice showed that DAT levels were not yet significantly increased after the last injection of RSV, which corresponds to four days from the first injection of RSV (fig. 10E). In parallel we examined the TH levels in the striatum and found no change of TH levels, suggesting a specificity of RSV effect on DAT. TH levels were used as index of nigrostriatal innervations and this was not changed by RSV treatment (fig. 10F).

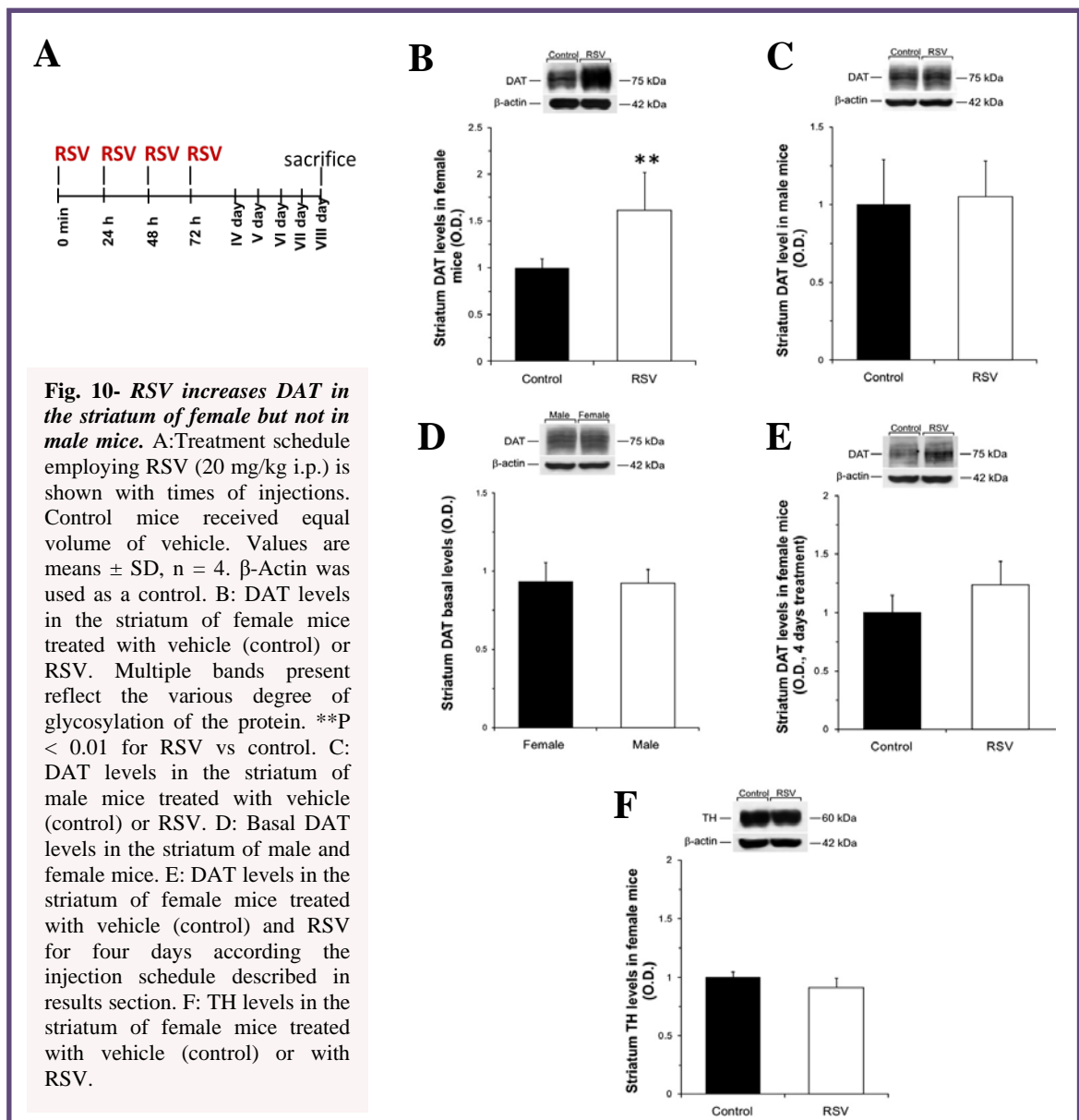
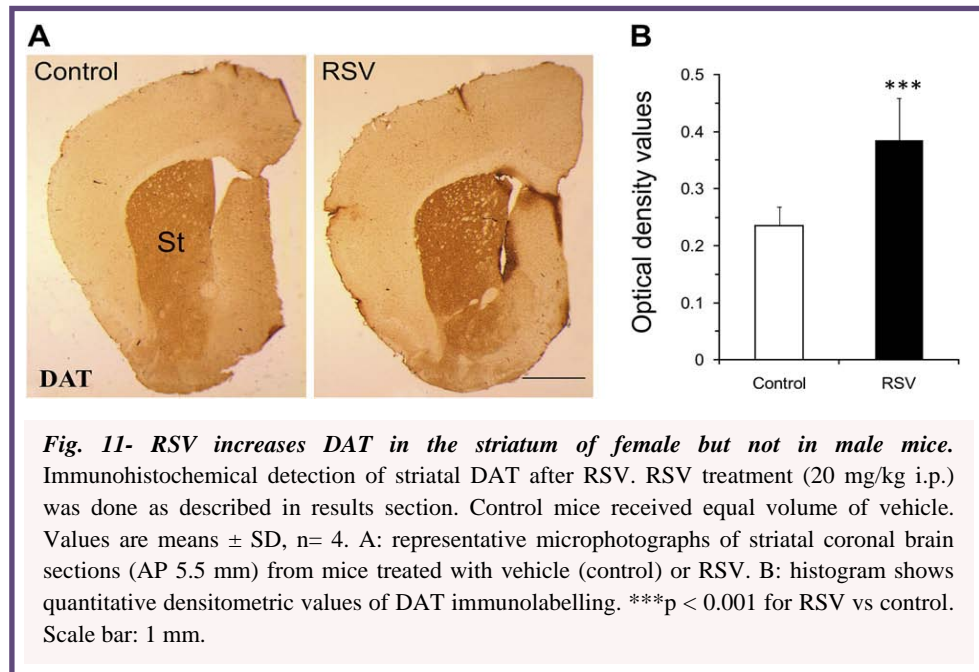

Fig. 10- RSV increases DAT in the striatum of female but not in male mice. A: Treatment schedule employing RSV (20 mg/kg i.p.) is shown with times of injections. Control mice received equal volume of vehicle. Values are means \pm SD, n = 4. β -Actin was used as a control. B: DAT levels in the striatum of female mice treated with vehicle (control) or RSV. Multiple bands present reflect the various degree of glycosylation of the protein. **P < 0.01 for RSV vs control. C: DAT levels in the striatum of male mice treated with vehicle (control) or RSV. D: Basal DAT levels in the striatum of male and female mice. E: DAT levels in the striatum of female mice treated with vehicle (control) and RSV for four days according the injection schedule described in results section. F: TH levels in the striatum of female mice treated with vehicle (control) or with RSV.

Result obtained by immunoblotting were substantiated using densitometric measurements of striatal DAT- immunostained sections, which revealed a significant increase in DAT-positive fiber staining in the striatum of female mice treated with RSV (fig. 11).



Estrogen receptors mediate RSV effect on DAT

To verify the involvement of estrogen receptors on RSV-enhanced DAT levels we performed a pretreatment of female mice with the selective estrogen receptor antagonist ICI 182,780. The dose and scheme of ICI 182,780 and RSV treatment were made as follow. Mice were daily pretreated with ICI 182,780 (2 mg/kg s.c.) and after 1,5h were treated with RSV (20mg/kg i.p.) and this treatment was repeated for four days and mice sacrificed at eighth day from the first injection (fig. 12A). One group of mice received the same number of injection with ICI 182,780 alone or RSV alone and an other control group of mice received the same number of injections with vehicle. The pretreatment with ICI 182,780 led to a complete block of RSV effect on DAT protein levels in the striatum as compared to control treated with vehicle or with RSV alone (fig.12B). The treatment with ICI 182,780 alone did not change the DAT levels in the striatum as compared to control treated with vehicle (fig.12B).

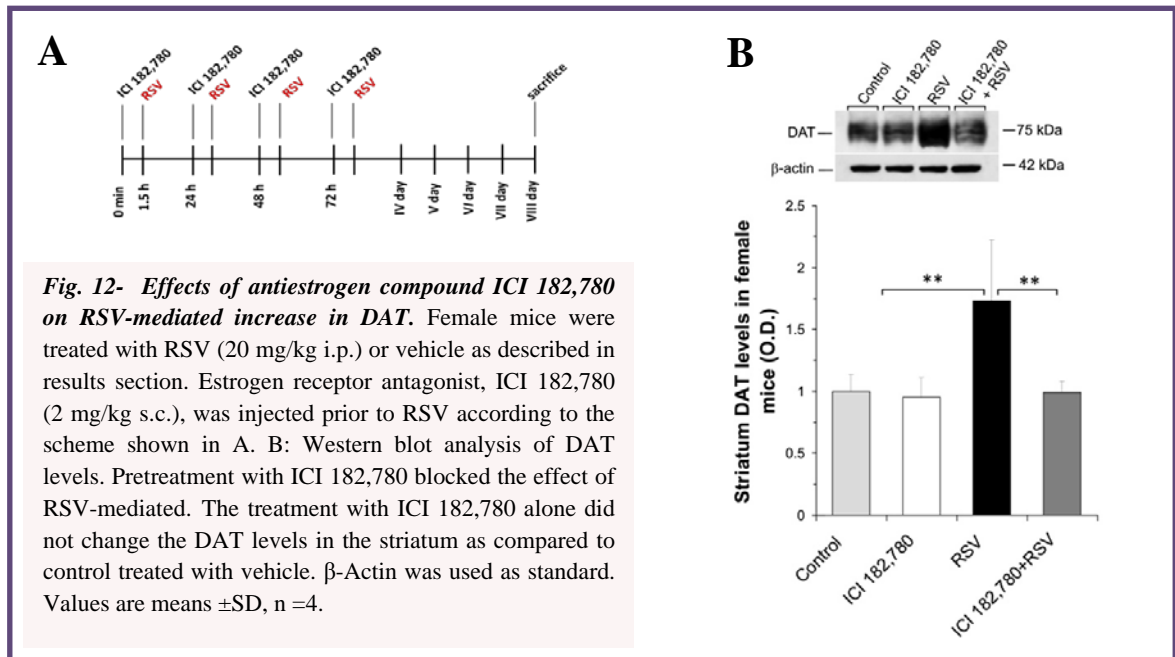

To confirm the observation made in vivo, using the mouse SN4741 cell line, we observed that the addition of 10μM RSV for 24h also increased DAT levels in dopaminergic cells SN4741 (fig 13A and 13B). Pretreatment with 2 μM of ICI 182,780 blocked the effect of RSV on DAT levels, as observed in vivo study.

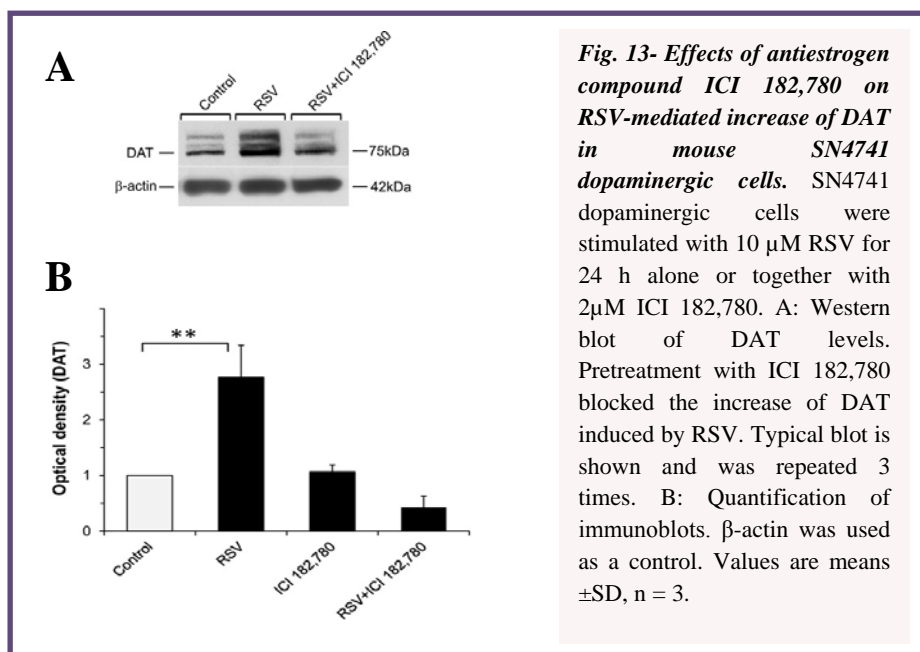

Mechanisms of RSV-mediated cell protection as studied in dopaminergic cells

Neuroprotective effect of RSV in SN4741 cells exposed to oxidative stress

To analyze the mechanisms of RSV action in dopaminergic cells in more detail, we studied cultured dopaminergic SN4741 cells that were originally established from mouse SN (Son et al. 1999). Treatment of these cells with 1-methyl-4-phenyl pyridinium (MPP⁺) at doses of 400 and 800 μM produced a significant loss in cell viability that was counteracted by the addition of 5-10 μM RSV (fig. 14A). Since MPP⁺ is known to produce ROS reactive oxidative species and oxidative stress in dopaminergic neurons, we evaluated ROS levels in the same models. We observed that MPP⁺ produced an increase in ROS in the SN4741 cells, and this was counteracted by the addition of RSV (fig. 14B).

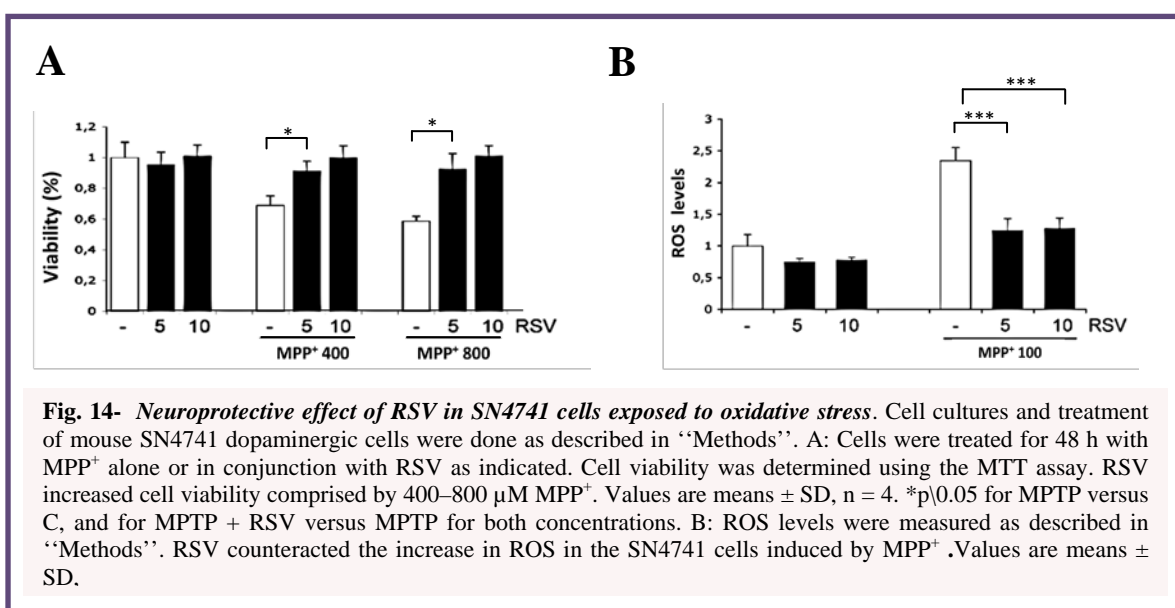

Effect of RSV on expression of antioxidant enzymes SOD2 and Trx2 in SN4741 cells

Since this antioxidant effect of RSV can also be due to its potential ability to promote the activities of a variety of antioxidant enzymes, we next examined in SN4741 cells using immunoblotting, the effect of RSV on expression of antioxidant enzymes SOD2 and Trx2, two mitochondrial antioxidant enzymes that could be involved in counteracting ROS formation. Data showed that RSV elevated SOD2 and Trx2 in the SN4741 cells, especially

at a dose of 10 μ M (fig. 15A and 15B). As control, we also evaluated the levels of SOD1, but have not seen it increased after treatment with RSV (fig. 15A). The increase in SOD2 by RSV was associated with an enhanced expression of SOD2-mRNA, as evaluated by RT-PCR (data not shown).

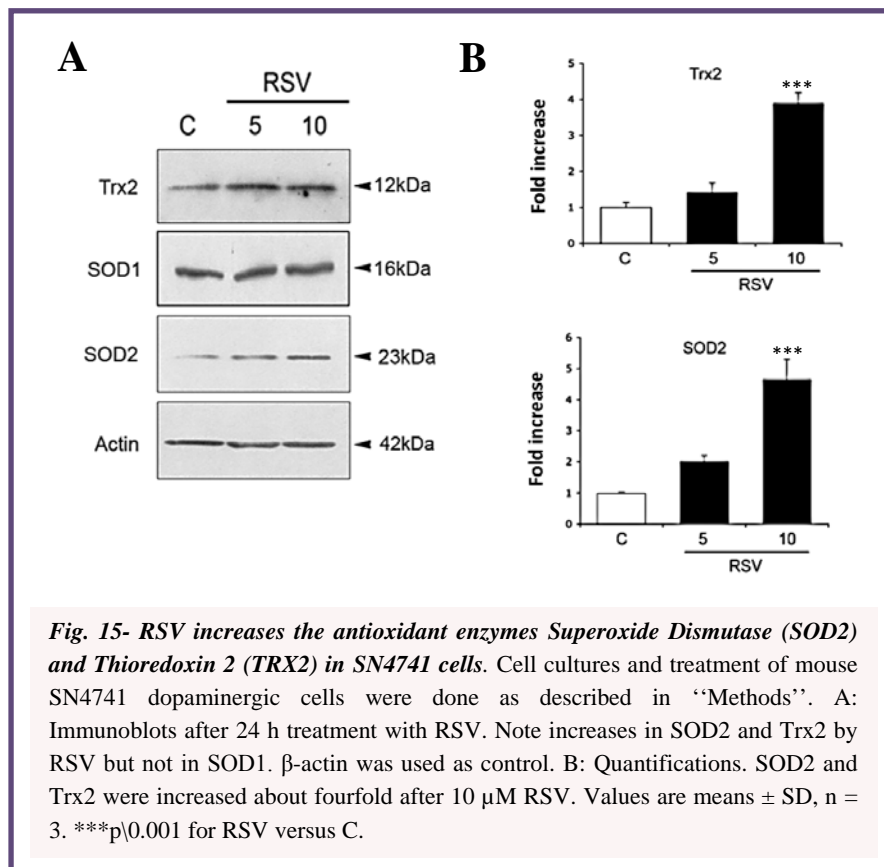

Effect of RSV on expression of PGC-1 α in SN4741.

In order to investigate the possible “neuroprotective signaling” involved in the mechanism of action of RSV, we evaluated in SN4741 cells the effect of RSV on expression of PGC-1 α , a coactivator involved in transcription of mitochondrial genes with antioxidant activity. In particular, the choice of studying the possible involvement of PGC-1 α in the mechanism of action of RSV was created by the recent evidence that PGC-1 α knockout mice are hypersensitive to the neurotoxin MPTP (St-Pierre et al. 2006) that causes degeneration of dopaminergic neurons in mice and in non-human primates. In

additionally, PGC-1 α is regulated by post-transcriptional modifications such as protein deacetylation by the mammalian SIRT1 protein which itself can be activated by RSV (Feige et al. 2008; Lagouge et al. 2006; Baur and Sinclair 2006). First we found that in SN4741 cells RSV increases levels of PGC-1 α and SIRT1 by immunoblotting (fig. 16A). Moreover, in order to evaluate whether the RSV was able to influence the activation status of PGC-1 α , we immunoprecipitated for PGC-1 α and used an antibody that recognizes its acetylated lysines as described in materials and methods. The degree of acetylation of PGC-1 α was reduced by about 40% (fig 16B) in SN4741 cells after treatment with RSV at a dose of 10 μ M. Thus, RSV has a dual effect on PGC-1 α in the dopaminergic cells, increasing both the activity and the levels of the protein. In contrast to this, the levels of catalase, heme oxygenase, or X-chromosome linked inhibitory apoptosis protein (XIAP) were not significantly altered by RSV in the dopaminergic cells (fig. 16C).

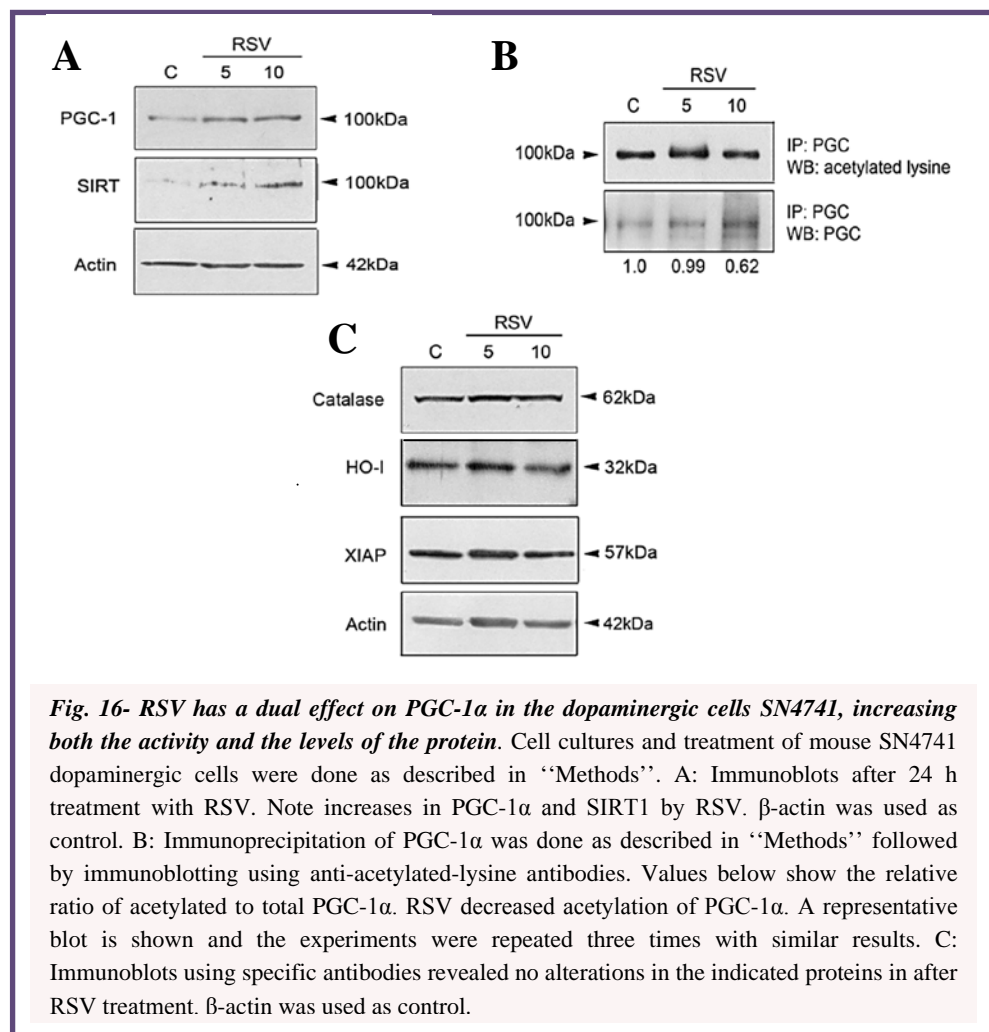

Effect of RSV on gene transcription of PGC-1 α in SN4741.

The increase in PGC-1 α levels by RSV was unexpected and promoted us to study whether RSV may influence PGC-1 α gene expression. To examine this, we employed PGC-1 α -promoter constructs linked to a luciferase reporter gene (St-Pierre et al. 2006). Data showed that the gene activity of the PGC-1 α was enhanced by about 80% in the SN4741 cells cultured in the presence of 10 μ M RSV (fig. 17A).

Likewise, in neuronal PC6.3 cells the increase in PGC-1 α promoter activity by 10 μ M RSV was about twofold (fig. 17B). Mutation in the MAD box transcription enhancer factor (MEF) site in the PGC-1 α -promoter reduced the induction in promoter activity brought about by RSV (fig. 17A). Mutation in the cAMP response element (Cre)- binding protein (CREB) site abolished the RSV-mediated increase and reduced the overall PGC-1 α -promoter activity (fig. 17A). This shows that the activity of the PGC-1 gene in neuronal cells is enhanced by RSV and involves the binding of various transcription factors to the promoter.

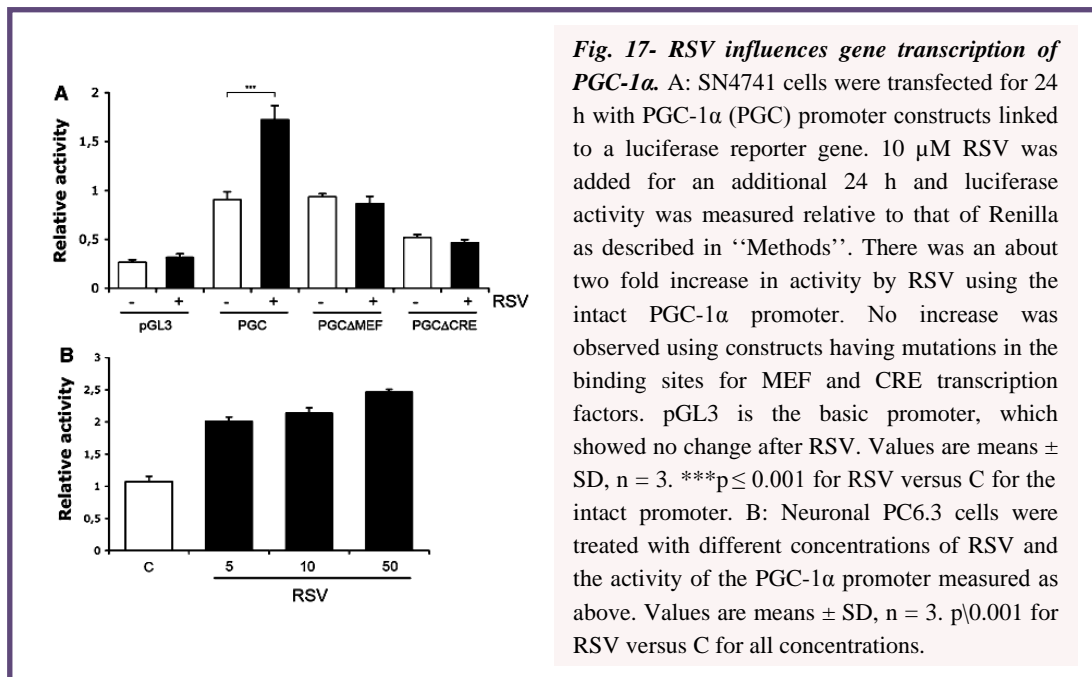

PGC-1 α transgenic mice are protected against MPTP-induced cell degeneration

Analyses of transgenic mice with overexpression of PGC-1 α in brain and in dopaminergic neurons.

The second aim of the present work was to explore the neuroprotective role of PGC-1 α in MPTP mouse model of PD, using transgenic mice overexpressing PGC-1 α (PGC1-tg). PGC-1 α is a master regulator of oxidative stress and mitochondrial metabolism. As shown in gene-deleted mice decreases in the levels of PGC-1 α influences neuronal viability and responses to injury in particular parts of the brain (St-Pierre et al. 2006). To study whether an overexpression of PGC-1 α may be neuroprotective in vivo, we generated transgenic mice expressing PGC-1 α in neurons under the control of the Thy-1 promoter (fig. 18A). By immunoblots we could show that the levels of PGC-1 α were increased in the nigrostriatal system in the transgenic compared with controls (fig. 18B). Immunostaining using anti-Flag antibodies revealed that the TH-positive dopaminergic neurons expressed Flag-PGC-1 α that was not observed in controls (fig. 18C).

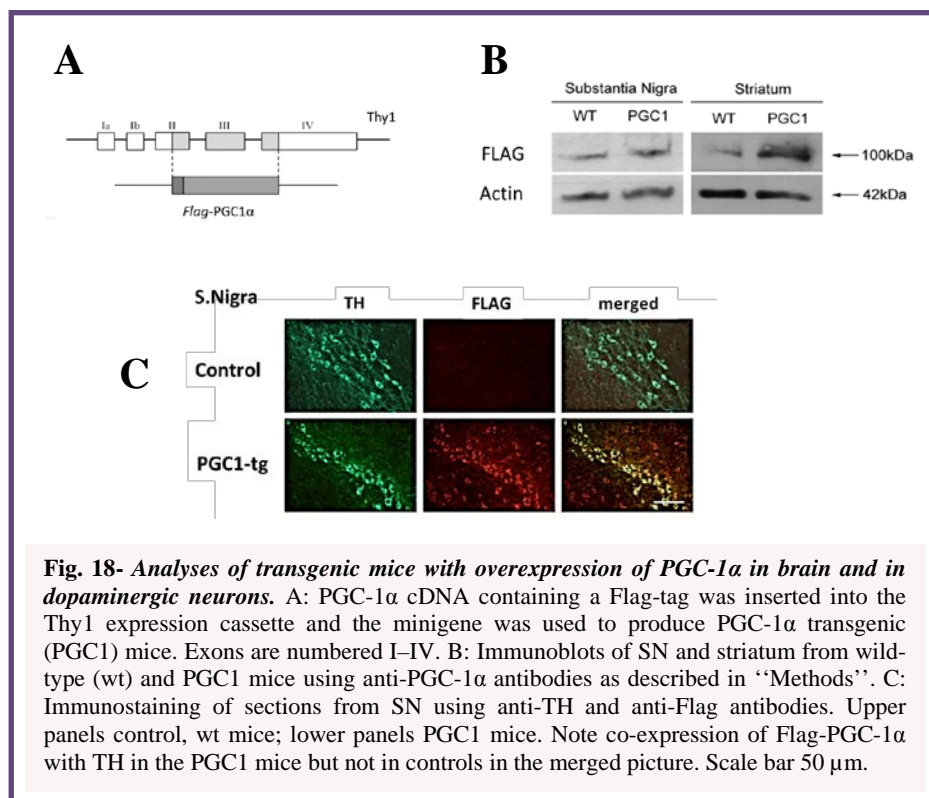

Effects of overexpression of PGC-1 α on mitochondrial antioxidants SOD2 and Trx2 and on the mitochondrial enzyme COXIV in SN

As PGC-1 α is known to influence different transcriptional programs, we studied the expression of some antioxidants and mitochondrial proteins involved in cell stress. Immunoblots of SN showed that the levels of the mitochondrial antioxidants, SOD2 and Trx2 are increased in the SN of PGC-1 α transgenic mice compared with wild-type animals (fig. 19A). Likewise, the mitochondrial enzyme COXIV was also elevated in the transgenic mice compared to controls (fig. 19A). The increase in protein levels in the PGC-1 α transgenic mice was accompanied by an enhanced gene expression, as shown here for SOD2 and COX IV using RT-PCR (fig. 19B). This shows that overexpression of PGC-1 α leads to changes in gene expression for a particular set of proteins in the SN with a potentially protective function in cell stress.

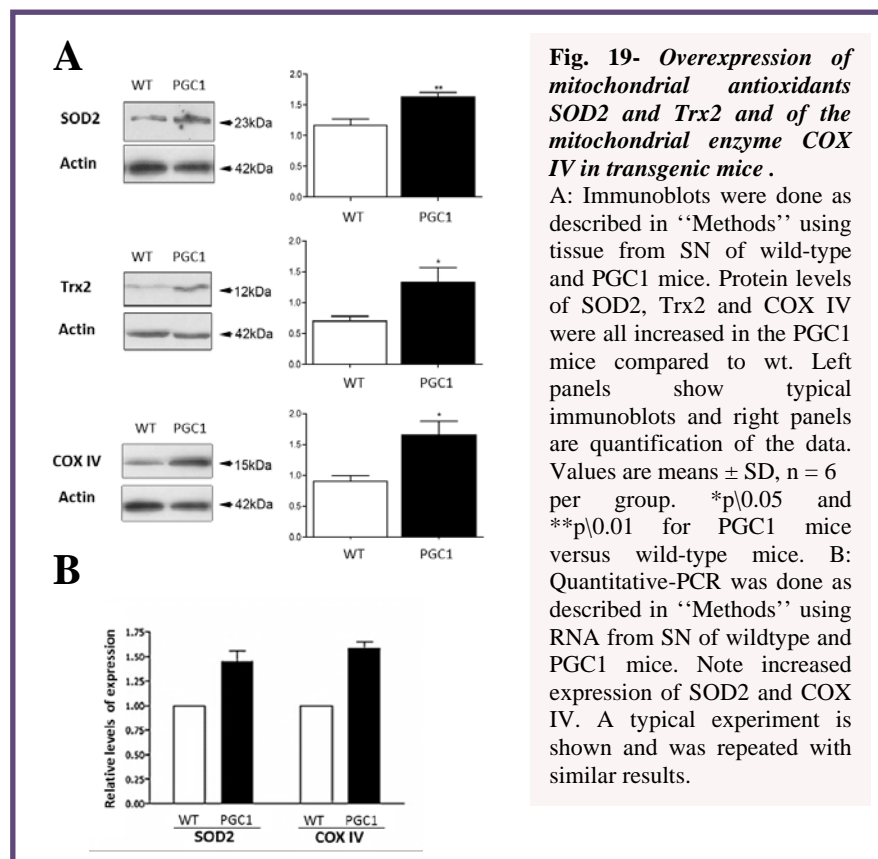

PGC-1 α protects against MPTP-induced neuronal degeneration in vivo in the SN

To study neuroprotection in the context of dopaminergic neurons, we treated the mice with the neurotoxin MPTP. Treatment of wild-type mice with MPTP is known to decrease the number of TH-positive neurons in the SNc (Thomas and Beal 2007), and this was also evident here as shown in figures 20A and 20B. However, in the PGC-1 α transgenic mice, the same treatment did not significantly reduce the number of TH-positive cells, indicating a robust neuroprotection (fig. 20A and B). Figure 20C shows that the number of NeuN-stained cells in the SNc in the PGC-1 α transgenic mice did not change after MPTP. In controls, the number of NeuN-positive neurons decreased in SNc as shown in figure 7D, and similar results using MPTP have been observed in several studies before. The preservation of NeuN-positive cells together with TH-positive neurons supports the view that PGC-1 α counteracts cell degeneration in SNc after MPTP treatment.

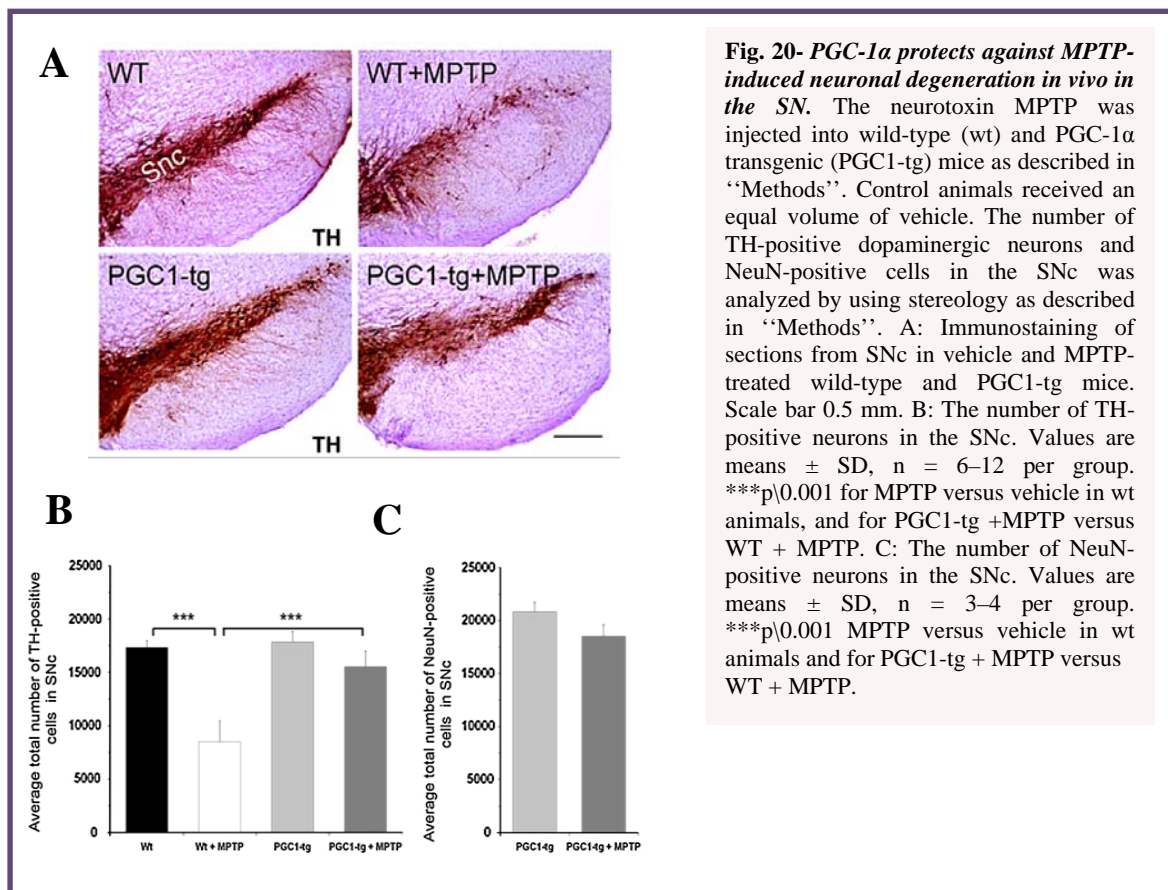

PGC-1 α protects against MPTP-induced neuronal degeneration in vivo in striatum

The neuroprotective role of PGC-1 α in transgenic mice observed in the SN, was also seen in the striatum. In fact, immunoblots of TH levels in the striatum showed a decrease in wild-type but not in PGC-1 α transgenic mice (fig. 21). In these experiments, we analyzed separately two transgenic mouse lines, PGC11 and PGC12 with similar expression of PGC-1 α in the brain, and obtained the same results (fig. 21). This shows that the transgenic expression of PGC-1 α can protect dopaminergic neurons against cell degeneration induced by MPTP.

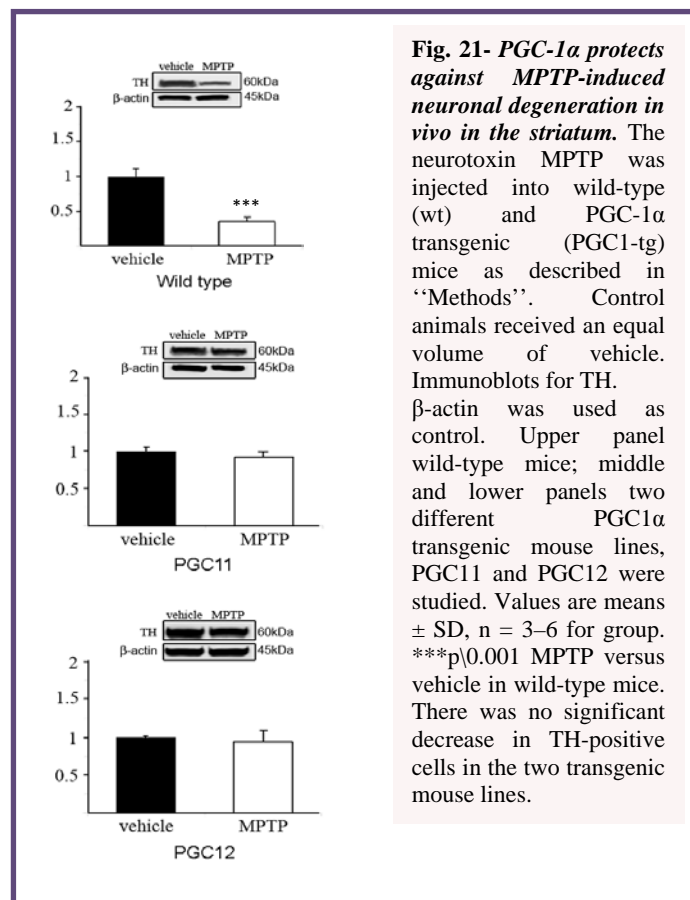
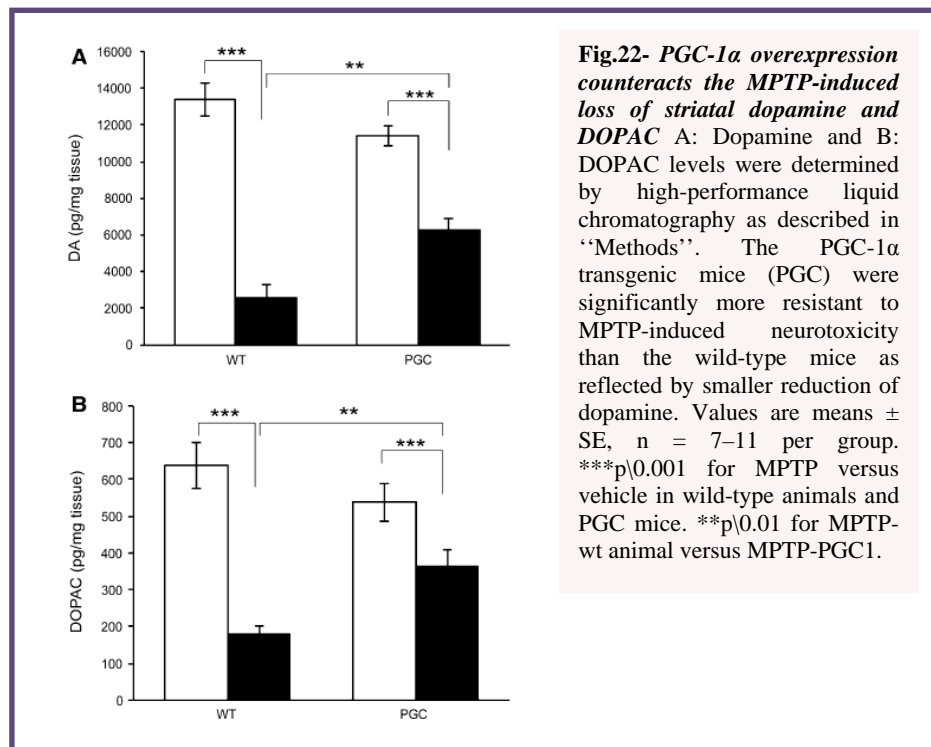

Fig. 21- PGC-1 α protects against MPTP-induced neuronal degeneration in vivo in the striatum. The neurotoxin MPTP was injected into wild-type (wt) and PGC-1 α transgenic (PGC1-tg) mice as described in ‘‘Methods’’. Control animals received an equal volume of vehicle. Immunoblots for TH. β -actin was used as control. Upper panel wild-type mice; middle and lower panels two different PGC1 α transgenic mouse lines, PGC11 and PGC12 were studied. Values are means \pm SD, n = 3–6 for group. ***p<0.001 MPTP versus vehicle in wild-type mice. There was no significant decrease in TH-positive cells in the two transgenic mouse lines.

PGC-1 α counteracts the decrease in striatal DA and DOPAC levels induced by MPTP

We measured the DA and DOPAC levels in wild-type and PGC-1 α transgenic mice after MPTP treatment. As expected (Heikkila et al. 1984), MPTP decreased the striatal concentration of dopamine and DOPAC and increased the DOPAC/dopamine ratio (fig. 22A and 22B). The PGC-1 α transgenic mice were significantly more resistant to MPTP-induced neurotoxicity than the wild-type mice as reflected by smaller reduction of dopamine and DOPAC (fig. 22A and 22B). In addition, the increase of dopamine/DOPAC ratio was lower in the PGC-1 α transgenic mice as compared to controls. Taken together, this data shows that the overexpression of PGC-1 α prevents changes in DA and DOPAC striatum induced by MPTP treatment showing a beneficial effect on the functional state of the nigrostriatal system in these mice.



PGC-1 α affects the respiration of isolated brain mitochondria

To explore the mechanisms for neuroprotection, we isolated mitochondria from the brains of PGC-1 α transgenic and wild-type mice. Measurements of mitochondrial oxygen consumption in vitro (Speer et al. 2003) showed an increased rate of respiratory control rate in mitochondria from PGC-1 α transgenic mice as compared to organelles from wild-type mice (fig. 23). The relative small difference observed (fig. 23) may be due to the fact that mitochondria were isolated from whole brain, thus including also glial cells, which have no expression of exogenous PGC-1 α driven by the Thy1 construct, being a neuron-specific promoter (Caroni 1997;Trapp et al. 2003). The higher respiratory control ratio observed in brain mitochondria from PGC-1 α transgenic mice indicates that the neuronal capacity for ATP production is higher in these mice compared to wild-type animals.

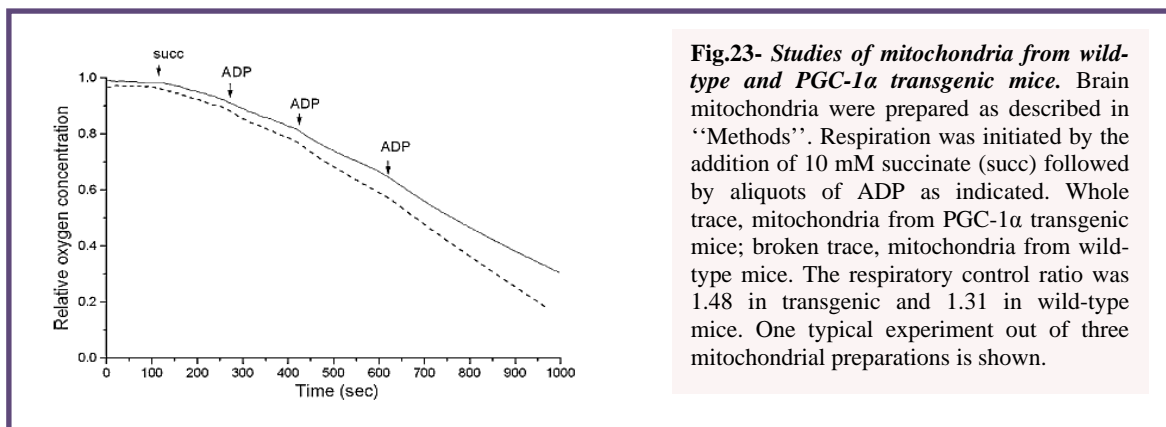

Discussion

Neuroprotective effects of RSV in dopaminergic neurons in vivo

Treatment with small molecular compounds appears to be an attractive means to combat nerve cell degeneration accompanying different brain diseases. In the present work using both in vivo and in vitro models, we defined the neuroprotective role of RSV, focusing our investigation on neuronal dopaminergic cells. To this end, we first evaluated neuroprotective effects of RSV both against MPTP-induced death of SNc in C57BL/6 mice and oxidative stress induced neuronal cell death in vitro model (SN4741 cells).

Subsequently, using in vitro model, we examined the possible mechanisms involved on RSV induced neuroprotection. We used MPTP administration to C57BL mice to cause a severe Parkinson-like syndrome (Langston and Irwin 1986;Kopin and Markey 1988;Heikkila et al. 1989;Calon et al. 2001) and, according to previous studies, we showed that MPTP administration to C57BL mice leads to the death of DA neurons in the SNc (Jakowec et al. 2004) as well as to a dramatically decline of striatal DA and TH levels. The dose and scheme of MPTP treatment used have been able to induce about 44% of TH-positive cells death in the SNc generating a severe condition of neuronal damage. In this model we could show a significant neuroprotection of RSV treatment; infact, co-treatment with 20 mg/kg RSV restored the number of TH-positive cells to 83% of control by the evaluation of dopaminergic cells number in the whole SNc performed both by stereological analysis and by double blind optical count. This neuroprotection has also been evaluated by measuring both TH and DAT proteins levels in the whole striatum, a parameter largely used as analysis of dopaminergic fiber density and therefore as index of dopaminergic neurons survival and efficient behavioral recovery in PD animal model.

While our investigation was in progress, Blanchet et al. reported that the administration of a diet containing RSV to adult mice prior to acute treatment with the toxin MPTP prevented cellular loss in the SNc in vivo (Blanchet et al. 2008). These data are in agreement with the present findings, although the different route of RSV

administration. However, there are some previous evidences suggesting that RSV treatment could elicit neuroprotective effects on different Parkinsonism models.

RSV protects dopaminergic neurons in midbrain slice cultures against metabolic and oxidative insults (Okawara et al. 2007) or in mice model against MPTP-induced hydroxyl radical overloading and neuronal loss (Lu et al. 2008) and in 6-OHDA-induced Parkinson's disease rat model (Jin et al. 2008). Taken together these and our data strengthen the idea that RSV may be used as therapy in neurodegenerative diseases of PD. The precise mechanisms and targets for RSV in brain tissue are not fully understood at the moment. We observed for example that the protection afforded by RSV on fiber density in striatum was less than that observed in SN on TH and DAT levels, possibly reflecting a difference in the action of RSV in the cell body and in the nerve terminals of TH-positive neurons that requires further studies.

One conclusion that can be drawn here is that the beneficial effect of RSV in neuroprotection was related to an increase in SOD2 in brain in vivo, probably contributing to the decrease in oxidative stress. In a recent study RSV reduces oxidative stress and cell death in neuronal PC6.3 increasing the levels of antioxidants, SOD2 and TRX2, and of X chromosome-linked inhibitor of apoptosis protein (Kairisalo et al. 2011).

RSV effect on DAT expression in the striatum of female mouse

Recent studies have evidenced a neuroprotective role for estrogens in PD (Garcia-Segura et al. 2001) and in MPTP-mice model or 6-OHDA-lesioned rats (Dluzen 2000; Ramirez et al. 2003; Murray et al. 2003). It is now recognized that estrogen replacement therapy in postmenopausal women reduces the risk of neurodegenerative PD diseases and that the antioxidant properties of estrogens contribute to their neuroprotective effects (Currie et al. 2004). On the other hand, RSV is a phytoestrogens, which are naturally occurring molecules that may exert similar neuroprotective effects as estrogens (Esposito et al. 2002).

The striking similarity of chemical structure of RSV to the synthetic estrogen diethylstilbestrol prompted us to consider the possibility that the extent of neuroprotective effects of RSV on MPTP model could be different in male mouse as compared to female mouse. The results showed that neuroprotective action of RSV against MPTP induced

dopaminergic neuron death does not change between male and female. However, during the course of these experiments, we have also show unexpectedly that RSV treatment in mice leads to a significant increase of DAT expression in the striatum of female but not of male mice. This gender difference and the striking similarity of chemical structure of RSV to the synthetic estrogen diethylstilbestrol (Gehm et al. 1997) suggested us to verify the possibility that RSV effects on DAT levels may be mediated by estrogen receptors. The results obtained both in vivo and in vitro (SN4741 cells) using the selective ER antagonist ICI 182,780 showed that estrogen receptors are involved in the up-regulation of DAT in the striatum. It has previously been shown using in situ hybridization and immunohistochemistry that ERs are present in the SN of adult rats (Shughrue et al. 1997;Zhang et al. 2002;Creutz and Kritzer 2002;Laflamme et al. 1998). Available data suggest that RSV is an agonist for ERs (Gehm et al. 1997) and may bind to both ER α and ER β (Bowers et al. 2000;Mueller et al. 2004;Robb and Stuart 2011;Wu et al. 2008). RSV may also activate the non-genomic ER-pathways stimulating intracellular phosphorylation events such as mitogen activated protein kinase signaling as shown in vascular endothelial cells (Klinge et al. 2005), and phosphatidylinositol-3-kinase signaling activation mediated by ER α (Pozo-Guisado et al. 2004). Concerning the binding affinities for RSV on ER it was previously shown that RSV activates estrogen-responsive reporter plasmids in the μ M range (Gehm et al. 1997), and in the present study we therefore used 10 μ M to stimulate dopaminergic neurons in our vitro model. Pretreatment with ICI 182,780 blocked the effect of RSV on DAT levels. Studies of DAT expression in dopaminergic cells showed that DAT mRNA is regulated by RSV that suggests a genomic effect of RSV via ICI 182,780-sensitive ERs. As ICI 182,780 all bind both to ER α and ER β (Kuiper et al. 1998;el-Mowafy et al. 2002;Pozo-Guisado et al. 2004;Bowers et al. 2000), is not possible to distinguish which estrogen receptor subtype is involved in the RSV action. Previously, it was reported that 2,3-bis (4-hydroxyphenyl)-propionitrile, that is an ER β agonist, mediates the estradiol mediated increase of striatal DAT (Le Saux and Di Paolo 2006), suggesting that ER β may be involved in the RSV increase in DAT in striatum. However, RSV has a structural similarity mainly to diethylstilbestrol that is an ER α agonist (Le Saux and Di Paolo 2006). It remains therefore to be studied which estrogen receptor subtype is involved in the RSV action in dopaminergic neurons and in brain in general.

The involvement of ERs in the regulation of DAT by RSV is in line with previous works showing an increase in DAT after estradiol treatment of female mouse (Jourdain et al. 2005). It has also been shown that ovariectomy and oestradiol affect DAT and its

expression in the rat striatum (Bosse et al. 1997) as well as in SNc (Morissette and Di 1993). In addition, in vivo imaging studies showed an increase in DAT in the putamen in postmenopausal women who received estrogen replacement therapy (Gardiner et al. 2004). Dopamine is an important brain neurotransmitter involved in locomotor processes as well as cognitive and emotional function. DAT is a key mediator of dopamine uptake and thus regulates the amount of dopamine in the synaptic cleft (Gainetdinov and Caron 2003). Studies have shown that DAT levels decrease with ageing and this is correlated with a deterioration in memory functions (Erixon-Lindroth et al. 2005).

The present results show that RSV increases DAT levels suggesting that RSV may have beneficial effects in ageing and in other cognitive disorders. Estrogen replacement therapy in postmenopausal women can reduce the risk of neurodegenerative diseases including PD (Dluzen 2000; Garcia-Segura et al. 2001; Currie et al. 2004). However, as shown in epidemiological studies there are other risks associated with longterm use of estrogens (Hulley and Grady 2004). However, so far the risks and neuroprotective roles of estrogen-like polyphenolic compounds, including RSV have not been analyzed in different neurodegenerative diseases (Ramassamy 2006).

Mechanisms of RSV-mediated dopaminergic cell protection

In the present work, following the in vivo evidence of neuroprotective action of RSV, we approached the in vitro model (SN4741 cells) in order to identify any potential molecular targets of RSV that give account of beneficial effects observed on dopaminergic neurons. In the MPTP mouse model of PD the catecholamine-degrading enzyme MAO B transforms MPTP into toxic metabolite in the astrocytes, MPP⁺ and dopaminergic neurons are the primary targets of MPP⁺, which accumulates in mitochondria and interrupts the complex I of the respiratory chain and promotes oxygen free radical formation (Adams, Jr. et al. 2001; Rajeswari 2006).

Based on this oxidative stress mechanism of MPTP induced dopaminergic cell death, we observed that treatment of these cells with 1-methyl-4-phenyl pyridinium (MPP⁺) at doses of 400 and 800 μM produced a significant loss in cell viability that was counteracted by the addition of 5-10 μM RSV. Subsequently, testing the RSV ability to

counteract ROS production under oxidative stress, it was possible to show a strong ability of RSV to reduce ROS production in both models of cells line used.

However, more interesting we found that RSV can protect dopaminergic neurons by enhancing effects on the expression levels of two antioxidant enzymes (SOD2 and Trx2). SOD2 and Trx2 regulate oxidative stress at the level of the mitochondria and these proteins are regulated in brain neurons partly by NF- κ B activation that is induced by various signals including XIAP (Kairisalo et al. 2007;Kairisalo et al. 2011).

In this study, we observed no change in NF- κ B signaling by RSV, suggesting another mechanism of action. An obvious candidate for this is SIRT1, which is an NAD⁺-dependent deacetylase involved in metabolic regulations and adaptations to stress (Feige et al. 2008;Lagouge et al. 2006). SIRT1 activity is linked to neuroprotection in Alzheimer's disease (Qin et al. 2006), and the protein is altered in motor neurons in ALS models (Kim et al. 2007). Previous studies have shown that RSV counteracts cell stress and activates PGC-1 α as well as AMP kinase in neurons (Baur and Sinclair 2006;Dasgupta and Milbrandt 2007).

We observed that RSV increased the levels of SIRT1 in the SN4741 cells and activated PGC-1 α by reducing acetylation of the protein. Apart from this, RSV increased the levels of PGC-1 α in the dopaminergic cells probably by affecting gene expression as shown using the PGC-1 α gene promoter constructs. This data was unexpected, and adds to the known biological effects of RSV with a focus particularly on neuronal cells and cell protection. Previous studies on RSV indicate that the compound is able to cross the blood–brain barrier (Baur and Sinclair 2006). RSV was reported to protect against brain damage induced by glutamate excitotoxicity, and after brain trauma and ischemia (Baur and Sinclair 2006;Della-Morte et al. 2009;Ates et al. 2007).

The present results obtained with RSV in dopaminergic cells suggest that RSV and other small molecular compounds acting via the SIRT1/PGC-1 α system may be useful agents for neuroprotection in PD. However, the potential use of RSV in different brain disorders will require careful analyzes of the kinetics, biological actions, and pharmacological profiles of the compound in brain tissue.

PGC-1 α transgenic mice are protected against MPTP-induced cell degeneration

On the basis of results revealing an increased levels and activity of PGC-1 α after treatment with RSV, we have also explored the neuroprotective role of PGC-1 α in MPTP mouse model of Parkinson's Disease, using transgenic mice overexpressing PGC-1 α (PGC1-tg). Therefore, in the present study, we used the well-characterized promoter, Thy1 that targets expression of PGC-1 α into brain neurons and allows for the study of neuron-specific changes after brain injuries (Trapp et al. 2003; Wang et al. 2004; Wootz et al. 2006; Zhu et al. 2007).

Using PGC-1 α transgenic mice, we were able to demonstrate that the overexpression of PGC-1 α in dopaminergic neurons partially counteracted cell degeneration induced by acute MPTP treatments. In PGC-1 α transgenic the number of TH-positive neurons in the SNc declining after MPTP was significantly protected and the decreases in DA and its metabolic DOPAC observed after MPTP were significantly less in these mice compared to wild-type ones. Together, this data underscores the importance of PGC-1 α signaling in neuroprotection of dopaminergic neurons, and adds to previous studies on the role of PGC-1 α in models of neuronal excitotoxicity and cell stress (St-Pierre et al. 2006; Lu et al. 2010).

The beneficial effect observed with the PGC-1 α transgenic was related to the overexpression of the PGC-1 α in dopaminergic neurons in the SN. However, the detailed mechanism by which PGC-1 α is neuroprotective in vivo remains to be studied, including the pattern of genes regulated PGC-1 α in neurons. We observed that mitochondria isolated from PGC-1 α transgenic mice had an increased respiratory control ratio compared with organelles from wild-type mice, suggesting an increased overall metabolic capacity. Whether this is due to increased turnover or dynamics of mitochondria in the PGC-1 α transgenic mice, remains to be studied.

Recently, it was shown that overexpression of PGC-1 α in cultured neurons increased the mitochondrial capacity and protected cells against mitochondrial loss induced by mutant α -synuclein and huntingtin proteins (Wareski et al. 2009). Previous studies on PGC-1 α expression in rat brain revealed a localization of PGC-1 α preferentially in GABAergic neurons with a weak immunostaining of neurons in the midbrain (Cowell et al. 2009).

It is reasonable to assume that the endogenous PGC-1 α levels in DA neurons are too low to be protective, but that higher levels of PGC-1 α can offer neuroprotection. Preliminary analyses on mice showed that other neurons than dopaminergic ones were also Flag-immunopositive in the SN of PGC-1 α transgenic mice. It will be important to analyze the nature of these neurons further, and whether they may somehow contribute to the neuroprotection observed here.

Conclusions

Overall, we have shown that the beneficial effect of RSV was dependent on its effects on PGC-1 α , a major regulator of cell metabolism and oxidative stress in cells, and on mitochondrial antioxidants, SOD2 and Trx2. Therefore, compounds acting, as the RSV, on PGC-1 α may protect cell degeneration in the SN against oxidative stress and may be useful as neuroprotective agents in Parkinson's Disease and possible in other neurological disorders.

Acknowledgements

I would like to thank all those persons that during the last three years, in various manners, have supported my work.

Especially thanks to Prof. Natale Belluardo, who introduced me to the world of the research, and guide me with professionalism during this beautiful and exciting experience. Thanks for his contagious passion for the research that stimulated me to do my work in a best way, and for his scientific support that contributed to my professional growth. Thanks for all his teachings which, I am sure, will be precious for my future.

Thanks also to D.ssa Giuseppa Mudò for her essential technical and moral support. Thanks for her words that encouraged me when the experiments do not work.

Thanks to my lab colleagues, Monica (especially), Valentina, Florinda, Maria, for the funny moments spent together.

Finally I want also say thanks to my parents who encouraged me and supported all my decisions.

Papers published during doctorate

Di Liberto V., Mäkelä J., Korhonen L., Olivieri M., Tselykh T., Mälkiä A., Do Thi H., Belluardo N., Lindholm D., Mudò G. Involvement of estrogen receptors in the RSV-mediated increase in dopamine transporter in human dopaminergic neurons and in striatum of female mice. *Neuropharmacology*. 2011 Oct 24.

Mudò G., Mäkelä J., Di Liberto V., Tselykh T.V., Olivieri M., Piepponen P., Eriksson O., Mälkiä A., Bonomo A., Kairisalo M., Aguirre J.A., Korhonen L., Belluardo N., Lindholm D. Transgenic expression and activation of PGC-1 α protect dopaminergic neurons in the MPTP mouse model of Parkinson's disease. *Cell Mol Life Sci*. 2011 Oct 8.

Frinchi M., Di Liberto V., Olivieri M., Fuxe K., Belluardo N., Mudò G. FGF-2/FGFR1 neurotrophic system expression level and its basal activation do not account for the age-dependent decline of precursor cell proliferation in the subventricular zone of rat brain. *Brain Res*. 2010 Oct 28;1358:39-45. Epub 2010 Sep 18.

Reference List

- Abou-Sleiman P. M., Muqit M. M. and Wood N. W. (2006) Expanding insights of mitochondrial dysfunction in Parkinson's disease. *Nat. Rev. Neurosci.* **7**, 207-219.
- Adams J. D., Jr., Chang M. L. and Klaidman L. (2001) Parkinson's disease--redox mechanisms. *Curr. Med. Chem.* **8**, 809-814.
- Aguirre J. A., Leo G., Cueto R., Andbjør B., Naylor A., Medhurst A. D., Agnati L. F. and Fuxe K. (2008) The novel cyclooxygenase-2 inhibitor GW637185X protects against 1-methyl-4-phenyl-1,2,3,6-tetrahydropyridine toxicity. *Neuroreport* **19**, 657-660.
- Airavaara M., Mijatovic J., Vihavainen T., Piepponen T. P., Saarma M. and Ahtee L. (2006) In heterozygous GDNF knockout mice the response of striatal dopaminergic system to acute morphine is altered. *Synapse* **59**, 321-329.
- Akao Y., Maruyama W., Yi H., Shamoto-Nagai M., Youdim M. B. and Naoi M. (2002) An anti-Parkinson's disease drug, N-propargyl-1(R)-aminoindan (rasagiline), enhances expression of anti-apoptotic bcl-2 in human dopaminergic SH-SY5Y cells. *Neurosci. Lett.* **326**, 105-108.
- Albani D., Polito L., Signorini A. and Forloni G. (2010) Neuroprotective properties of RSV in different neurodegenerative disorders. *Biofactors* **36**, 370-376.
- Alexandrova M. L. and Bochev P. G. (2005) Oxidative stress during the chronic phase after stroke. *Free Radic. Biol. Med.* **39**, 297-316.
- Andersson U. and Scarpulla R. C. (2001) Pgc-1-related coactivator, a novel, serum-inducible coactivator of nuclear respiratory factor 1-dependent transcription in mammalian cells. *Mol. Cell Biol.* **21**, 3738-3749.
- Arvanitoyannis I. S. and Giakoundis A. (2006) Current strategies for dairy waste management: a review. *Crit Rev. Food Sci. Nutr.* **46**, 379-390.
- Ates O., Cayli S., Altinoz E., Gurses I., Yucel N., Sener M., Kocak A. and Yologlu S. (2007) Neuroprotection by RSV against traumatic brain injury in rats. *Mol. Cell Biochem.* **294**, 137-144.
- Banerjee R., Starkov A. A., Beal M. F. and Thomas B. (2009) Mitochondrial dysfunction in the limelight of Parkinson's disease pathogenesis. *Biochim. Biophys. Acta* **1792**, 651-663.
- Bar A. O., Amit T. and Youdim M. B. (2004) Contrasting neuroprotective and neurotoxic actions of respective metabolites of anti-Parkinson drugs rasagiline and selegiline. *Neurosci. Lett.* **355**, 169-172.
- Baur J. A., Pearson K. J., Price N. L., Jamieson H. A., Lerin C., Kalra A., Prabhu V. V., Allard J. S., Lopez-Lluch G., Lewis K., Pistell P. J., Poosala S., Becker K. G., Boss O., Gwinn D., Wang M., Ramaswamy S., Fishbein K. W., Spencer R. G., Lakatta E. G., Le C. D., Shaw R. J., Navas P., Puigserver P., Ingram D. K., de C. R. and Sinclair D. A. (2006) RSV improves health and survival of mice on a high-calorie diet. *Nature* **444**, 337-342.

- Baur J. A. and Sinclair D. A. (2006) Therapeutic potential of RSV: the in vivo evidence. *Nat. Rev. Drug Discov.* **5**, 493-506.
- Beal M. F. (2005) Mitochondria take center stage in aging and neurodegeneration. *Ann. Neurol.* **58**, 495-505.
- Beal M. F., Palomo T., Kostrzewa R. M. and Archer T. (2000) Neuroprotective and neurorestorative strategies for neuronal injury. *Neurotox. Res.* **2**, 71-84.
- Bender A., Krishnan K. J., Morris C. M., Taylor G. A., Reeve A. K., Perry R. H., Jaros E., Hersheson J. S., Betts J., Klopstock T., Taylor R. W. and Turnbull D. M. (2006) High levels of mitochondrial DNA deletions in substantia nigra neurons in aging and Parkinson disease. *Nat. Genet.* **38**, 515-517.
- Bezard E., Gerlach I., Moratalla R., Gross C. E. and Jork R. (2006) 5-HT_{1A} receptor agonist-mediated protection from MPTP toxicity in mouse and macaque models of Parkinson's disease. *Neurobiol. Dis.* **23**, 77-86.
- Blanchet J., Longpre F., Bureau G., Morissette M., DiPaolo T., Bronchti G. and Martinoli M. G. (2008) RSV, a red wine polyphenol, protects dopaminergic neurons in MPTP-treated mice. *Prog. Neuropsychopharmacol. Biol. Psychiatry* **32**, 1243-1250.
- Bonifati V., Rizzu P., van Baren M. J., Schaap O., Breedveld G. J., Krieger E., Dekker M. C., Squitieri F., Ibanez P., Joosse M., van Dongen J. W., Vanacore N., van Swieten J. C., Brice A., Meco G., van Duijn C. M., Oostra B. A. and Heutink P. (2003) Mutations in the DJ-1 gene associated with autosomal recessive early-onset parkinsonism. *Science* **299**, 256-259.
- Borgius L. J., Steffensen K. R., Gustafsson J. A. and Treuter E. (2002) Glucocorticoid signaling is perturbed by the atypical orphan receptor and corepressor SHP. *J. Biol. Chem.* **277**, 49761-49766.
- Bosse R., Rivest R. and Di P. T. (1997) Ovariectomy and estradiol treatment affect the dopamine transporter and its gene expression in the rat brain. *Brain Res. Mol. Brain Res.* **46**, 343-346.
- Bowers J. L., Tyulmenkov V. V., Jernigan S. C. and Klinge C. M. (2000) RSV acts as a mixed agonist/antagonist for estrogen receptors alpha and beta. *Endocrinology* **141**, 3657-3667.
- Braak H., Braak E., Yilmazer D., Schultz C., de Vos R. A. and Jansen E. N. (1995) Nigral and extranigral pathology in Parkinson's disease. *J. Neural Transm. Suppl* **46**, 15-31.
- Bringmann G., God R., Feineis D., Janetzky B. and Reichmann H. (1995a) TaClo as a neurotoxic lead: improved synthesis, stereochemical analysis, and inhibition of the mitochondrial respiratory chain. *J. Neural Transm. Suppl* **46**, 245-254.
- Bringmann G., God R., Feineis D., Wesemann W., Riederer P., Rausch W. D., Reichmann H. and Sontag K. H. (1995b) The TaClo concept: 1-trichloromethyl-1,2,3,4-tetrahydro-beta-carboline (TaClo), a new toxin for dopaminergic neurons. *J. Neural Transm. Suppl* **46**, 235-244.

- Brunet A., Sweeney L. B., Sturgill J. F., Chua K. F., Greer P. L., Lin Y., Tran H., Ross S. E., Mostoslavsky R., Cohen H. Y., Hu L. S., Cheng H. L., Jedrychowski M. P., Gygi S. P., Sinclair D. A., Alt F. W. and Greenberg M. E. (2004) Stress-dependent regulation of FOXO transcription factors by the SIRT1 deacetylase. *Science* **303**, 2011-2015.
- Calon F., Lavertu N., Lemieux A. M., Morissette M., Goulet M., Grondin R., Blanchet P. J., Bedard P. J. and Di P. T. (2001) Effect of MPTP-induced denervation on basal ganglia GABA(B) receptors: correlation with dopamine concentrations and dopamine transporter. *Synapse* **40**, 225-234.
- Canto C. and Auwerx J. (2009) PGC-1alpha, SIRT1 and AMPK, an energy sensing network that controls energy expenditure. *Curr. Opin. Lipidol.* **20**, 98-105.
- Carlile G. W., Chalmers-Redman R. M., Tatton N. A., Pong A., Borden K. E. and Tatton W. G. (2000) Reduced apoptosis after nerve growth factor and serum withdrawal: conversion of tetrameric glyceraldehyde-3-phosphate dehydrogenase to a dimer. *Mol. Pharmacol.* **57**, 2-12.
- Caroni P. (1997) Overexpression of growth-associated proteins in the neurons of adult transgenic mice. *J. Neurosci. Methods* **71**, 3-9.
- Chao J., Yu M. S., Ho Y. S., Wang M. and Chang R. C. (2008) Dietary oxyRSV prevents parkinsonian mimetic 6-hydroxydopamine neurotoxicity. *Free Radic. Biol. Med.* **45**, 1019-1026.
- Chaturvedi R. K., Calingasan N. Y., Yang L., Hennessey T., Johri A. and Beal M. F. (2010) Impairment of PGC-1alpha expression, neuropathology and hepatic steatosis in a transgenic mouse model of Huntington's disease following chronic energy deprivation. *Hum. Mol. Genet.* **19**, 3190-3205.
- Checkoway H., Powers K., Smith-Weller T., Franklin G. M., Longstreth W. T., Jr. and Swanson P. D. (2002) Parkinson's disease risks associated with cigarette smoking, alcohol consumption, and caffeine intake. *Am. J. Epidemiol.* **155**, 732-738.
- Cleeter M. W., Cooper J. M. and Schapira A. H. (1992) Irreversible inhibition of mitochondrial complex I by 1-methyl-4-phenylpyridinium: evidence for free radical involvement. *J. Neurochem.* **58**, 786-789.
- Clow A., Freestone C., Lewis E., Dexter D., Sandler M. and Glover V. (1993) The effect of pergolide and MDL 72974 on rat brain CuZn superoxide dismutase. *Neurosci. Lett.* **164**, 41-43.
- Cowell R. M., Talati P., Blake K. R., Meador-Woodruff J. H. and Russell J. W. (2009) Identification of novel targets for PGC-1alpha and histone deacetylase inhibitors in neuroblastoma cells. *Biochem. Biophys. Res. Commun.* **379**, 578-582.
- Coyle J. T. and Puttfarcken P. (1993) Oxidative stress, glutamate, and neurodegenerative disorders. *Science* **262**, 689-695.
- Creutz L. M. and Kritzer M. F. (2002) Estrogen receptor-beta immunoreactivity in the midbrain of adult rats: regional, subregional, and cellular localization in the A10, A9, and A8 dopamine cell groups. *J. Comp Neurol.* **446**, 288-300.

- Cui L., Jeong H., Borovecki F., Parkhurst C. N., Tanese N. and Krainc D. (2006) Transcriptional repression of PGC-1alpha by mutant huntingtin leads to mitochondrial dysfunction and neurodegeneration. *Cell* **127**, 59-69.
- Currie L. J., Harrison M. B., Trugman J. M., Bennett J. P. and Wooten G. F. (2004) Postmenopausal estrogen use affects risk for Parkinson disease. *Arch. Neurol.* **61**, 886-888.
- Dasgupta B. and Milbrandt J. (2007) RSV stimulates AMP kinase activity in neurons. *Proc. Natl. Acad. Sci. U. S. A* **104**, 7217-7222.
- Dauer W. and Przedborski S. (2003) Parkinson's disease: mechanisms and models. *Neuron* **39**, 889-909.
- Davis G. C., Williams A. C., Markey S. P., Ebert M. H., Caine E. D., Reichert C. M. and Kopin I. J. (1979) Chronic Parkinsonism secondary to intravenous injection of meperidine analogues. *Psychiatry Res.* **1**, 249-254.
- de la Lastra C. A. and Villegas I. (2005) RSV as an anti-inflammatory and anti-aging agent: mechanisms and clinical implications. *Mol. Nutr. Food Res.* **49**, 405-430.
- de Lau L. M. and Breteler M. M. (2006) Epidemiology of Parkinson's disease. *Lancet Neurol.* **5**, 525-535.
- Della-Morte D., Dave K. R., DeFazio R. A., Bao Y. C., Raval A. P. and Perez-Pinzon M. A. (2009) RSV pretreatment protects rat brain from cerebral ischemic damage via a sirtuin 1-uncoupling protein 2 pathway. *Neuroscience* **159**, 993-1002.
- Dluzen D. E. (2000) Neuroprotective effects of estrogen upon the nigrostriatal dopaminergic system. *J. Neurocytol.* **29**, 387-399.
- Drechsel D. A. and Patel M. (2008) Role of reactive oxygen species in the neurotoxicity of environmental agents implicated in Parkinson's disease. *Free Radic. Biol. Med.* **44**, 1873-1886.
- Ebadi M. and Sharma S. K. (2003) Peroxynitrite and mitochondrial dysfunction in the pathogenesis of Parkinson's disease. *Antioxid. Redox. Signal.* **5**, 319-335.
- el-Mowafy A. M., Abou-Zeid L. A. and Edafiogho I. (2002) Recognition of RSV by the human estrogen receptor-alpha: a molecular modeling approach to understand its biological actions. *Med. Princ. Pract.* **11**, 86-92.
- Erixon-Lindroth N., Farde L., Wahlin T. B., Sovago J., Halldin C. and Backman L. (2005) The role of the striatal dopamine transporter in cognitive aging. *Psychiatry Res.* **138**, 1-12.
- Esposito E., Rotilio D., Di M., V, Di G. C., Cacchio M. and Algeri S. (2002) A review of specific dietary antioxidants and the effects on biochemical mechanisms related to neurodegenerative processes. *Neurobiol. Aging* **23**, 719-735.
- Fahn S. (2003) Description of Parkinson's disease as a clinical syndrome. *Ann. N. Y. Acad. Sci.* **991**, 1-14.
- Fang Y. Z., Yang S. and Wu G. (2002) Free radicals, antioxidants, and nutrition. *Nutrition* **18**, 872-879.

- Feige J. N., Lagouge M., Canto C., Strehle A., Houten S. M., Milne J. C., Lambert P. D., Matakis C., Elliott P. J. and Auwerx J. (2008) Specific SIRT1 activation mimics low energy levels and protects against diet-induced metabolic disorders by enhancing fat oxidation. *Cell Metab* **8**, 347-358.
- Finotti N., Castagna L., Moretti A. and Marzatico F. (2000) Reduction of lipid peroxidation in different rat brain areas after cabergoline treatment. *Pharmacol. Res.* **42**, 287-291.
- Floyd R. A., Towner R. A., He T., Hensley K. and Maples K. R. (2011) Translational research involving oxidative stress and diseases of aging. *Free Radic. Biol. Med.* **51**, 931-941.
- Gainetdinov R. R. and Caron M. G. (2003) Monoamine transporters: from genes to behavior. *Annu. Rev. Pharmacol. Toxicol.* **43**, 261-284.
- Garcia-Segura L. M., Azcoitia I. and DonCarlos L. L. (2001) Neuroprotection by estradiol. *Prog. Neurobiol.* **63**, 29-60.
- Gardiner S. A., Morrison M. F., Mozley P. D., Mozley L. H., Brensinger C., Bilker W., Newberg A. and Battistini M. (2004) Pilot study on the effect of estrogen replacement therapy on brain dopamine transporter availability in healthy, postmenopausal women. *Am. J. Geriatr. Psychiatry* **12**, 621-630.
- Gassen M., Glinka Y., Pinchasi B. and Youdim M. B. (1996) Apomorphine is a highly potent free radical scavenger in rat brain mitochondrial fraction. *Eur. J. Pharmacol.* **308**, 219-225.
- Gehm B. D., McAndrews J. M., Chien P. Y. and Jameson J. L. (1997) RSV, a polyphenolic compound found in grapes and wine, is an agonist for the estrogen receptor. *Proc. Natl. Acad. Sci. U. S. A* **94**, 14138-14143.
- Gelinas S. and Martinoli M. G. (2002) Neuroprotective effect of estradiol and phytoestrogens on MPP⁺-induced cytotoxicity in neuronal PC12 cells. *J. Neurosci. Res.* **70**, 90-96.
- Gerhart-Hines Z., Rodgers J. T., Bare O., Lerin C., Kim S. H., Mostoslavsky R., Alt F. W., Wu Z. and Puigserver P. (2007) Metabolic control of muscle mitochondrial function and fatty acid oxidation through SIRT1/PGC-1 α . *EMBO J.* **26**, 1913-1923.
- Gilgun-Sherki Y., Rosenbaum Z., Melamed E. and Offen D. (2002) Antioxidant therapy in acute central nervous system injury: current state. *Pharmacol. Rev.* **54**, 271-284.
- Gilman S. C., Bonner M. J. and Pellmar T. C. (1993) Effect of oxidative stress on excitatory amino acid release by cerebral cortical synaptosomes. *Free Radic. Biol. Med.* **15**, 671-675.
- Ginsberg M. D. (2008) Neuroprotection for ischemic stroke: past, present and future. *Neuropharmacology* **55**, 363-389.
- Gomez-Vargas M., Nishibayashi-Asanuma S., Asanuma M., Kondo Y., Iwata E. and Ogawa N. (1998) Pergolide scavenges both hydroxyl and nitric oxide free radicals in vitro

and inhibits lipid peroxidation in different regions of the rat brain. *Brain Res.* **790**, 202-208.

Graham D. G. (1978) Oxidative pathways for catecholamines in the genesis of neuromelanin and cytotoxic quinones. *Mol. Pharmacol.* **14**, 633-643.

Graham D. G., Tiffany S. M., Bell W. R., Jr. and Gutknecht W. F. (1978) Autoxidation versus covalent binding of quinones as the mechanism of toxicity of dopamine, 6-hydroxydopamine, and related compounds toward C1300 neuroblastoma cells in vitro. *Mol. Pharmacol.* **14**, 644-653.

Greenamyre J. T., MacKenzie G., Peng T. I. and Stephans S. E. (1999) Mitochondrial dysfunction in Parkinson's disease. *Biochem. Soc. Symp.* **66**, 85-97.

Guillot T. S. and Miller G. W. (2009) Protective actions of the vesicular monoamine transporter 2 (VMAT2) in monoaminergic neurons. *Mol. Neurobiol.* **39**, 149-170.

Gupta A., Dawson V. L. and Dawson T. M. (2008) What causes cell death in Parkinson's disease? *Ann. Neurol.* **64 Suppl 2**, S3-15.

Gupta Y. K., Gupta M. and Kohli K. (2003) Neuroprotective role of melatonin in oxidative stress vulnerable brain. *Indian J. Physiol Pharmacol.* **47**, 373-386.

Halliwell B. (2001) Role of free radicals in the neurodegenerative diseases: therapeutic implications for antioxidant treatment. *Drugs Aging* **18**, 685-716.

Halliwell B. (2006) Oxidative stress and neurodegeneration: where are we now? *J. Neurochem.* **97**, 1634-1658.

Halliwell B. and Gutteridge J. M. (1992) Biologically relevant metal ion-dependent hydroxyl radical generation. An update. *FEBS Lett.* **307**, 108-112.

Heikkila R. E., Cabbat F. S., Manzano L. and Duvoisin R. C. (1984) Effects of 1-methyl-4-phenyl-1,2,5,6-tetrahydropyridine on neostriatal dopamine in mice. *Neuropharmacology* **23**, 711-713.

Heikkila R. E., Sieber B. A., Manzano L. and Sonsalla P. K. (1989) Some features of the nigrostriatal dopaminergic neurotoxin 1-methyl-4-phenyl-1,2,3,6-tetrahydropyridine (MPTP) in the mouse. *Mol. Chem. Neuropathol.* **10**, 171-183.

Ho L., Chen L. H., Wang J., Zhao W., Talcott S. T., Ono K., Teplow D., Humala N., Cheng A., Percival S. S., Ferruzzi M., Janle E., Dickstein D. L. and Pasinetti G. M. (2009) Heterogeneity in red wine polyphenolic contents differentially influences Alzheimer's disease-type neuropathology and cognitive deterioration. *J. Alzheimers. Dis.* **16**, 59-72.

Hong C., Duit S., Jalonen P., Out R., Scheer L., Sorrentino V., Boyadjian R., Rodenburg K. W., Foley E., Korhonen L., Lindholm D., Nimpf J., van Berkel T. J., Tontonoz P. and Zelcer N. (2010) The E3 ubiquitin ligase IDOL induces the degradation of the low density lipoprotein receptor family members VLDLR and ApoER2. *J. Biol. Chem.* **285**, 19720-19726.

Hornykiewicz O. and Kish S. J. (1987) Biochemical pathophysiology of Parkinson's disease. *Adv. Neurol.* **45**, 19-34.

Howitz K. T., Bitterman K. J., Cohen H. Y., Lamming D. W., Lavu S., Wood J. G., Zipkin R. E., Chung P., Kisielewski A., Zhang L. L., Scherer B. and Sinclair D. A. (2003) Small molecule activators of sirtuins extend *Saccharomyces cerevisiae* lifespan. *Nature* **425**, 191-196.

Hulley S. B. and Grady D. (2004) The WHI estrogen-alone trial--do things look any better? *JAMA* **291**, 1769-1771.

Ienco E. C., Simoncini C., Orsucci D., Petrucci L., Filosto M., Mancuso M. and Siciliano G. (2011) May "mitochondrial eve" and mitochondrial haplogroups play a role in neurodegeneration and Alzheimer's disease? *Int. J. Alzheimers. Dis.* **2011**, 709061.

Ignatowicz E. and Baer-Dubowska W. (2001) RSV, a natural chemopreventive agent against degenerative diseases. *Pol. J. Pharmacol.* **53**, 557-569.

Iida M., Miyazaki I., Tanaka K., Kabuto H., Iwata-Ichikawa E. and Ogawa N. (1999) Dopamine D2 receptor-mediated antioxidant and neuroprotective effects of ropinirole, a dopamine agonist. *Brain Res.* **838**, 51-59.

Jakowec M. W., Nixon K., Hogg E., McNeill T. and Petzinger G. M. (2004) Tyrosine hydroxylase and dopamine transporter expression following 1-methyl-4-phenyl-1,2,3,6-tetrahydropyridine-induced neurodegeneration of the mouse nigrostriatal pathway. *J. Neurosci. Res.* **76**, 539-550.

Jankovic J. (2002) Levodopa strengths and weaknesses. *Neurology* **58**, S19-S32.

Jin F., Wu Q., Lu Y. F., Gong Q. H. and Shi J. S. (2008) Neuroprotective effect of RSV on 6-OHDA-induced Parkinson's disease in rats. *Eur. J. Pharmacol.* **600**, 78-82.

Jourdain S., Morissette M., Morin N. and Di P. T. (2005) Oestrogens prevent loss of dopamine transporter (DAT) and vesicular monoamine transporter (VMAT2) in substantia nigra of 1-methyl-4-phenyl-1,2,3,6-tetrahydropyridine mice. *J. Neuroendocrinol.* **17**, 509-517.

Kairisalo M., Bonomo A., Hyrskyluoto A., Mudo G., Belluardo N., Korhonen L. and Lindholm D. (2011) RSV reduces oxidative stress and cell death and increases mitochondrial antioxidants and XIAP in PC6.3-cells. *Neurosci. Lett.* **488**, 263-266.

Kairisalo M., Korhonen L., Blomgren K. and Lindholm D. (2007) X-linked inhibitor of apoptosis protein increases mitochondrial antioxidants through NF-kappaB activation. *Biochem. Biophys. Res. Commun.* **364**, 138-144.

Kairisalo M., Korhonen L., Sepp M., Pruunsild P., Kukkonen J. P., Kivinen J., Timmusk T., Blomgren K. and Lindholm D. (2009) NF-kappaB-dependent regulation of brain-derived neurotrophic factor in hippocampal neurons by X-linked inhibitor of apoptosis protein. *Eur. J. Neurosci.* **30**, 958-966.

Keeney P. M., Xie J., Capaldi R. A. and Bennett J. P., Jr. (2006) Parkinson's disease brain mitochondrial complex I has oxidatively damaged subunits and is functionally impaired and misassembled. *J. Neurosci.* **26**, 5256-5264.

Kim D., Nguyen M. D., Dobbin M. M., Fischer A., Sananbenesi F., Rodgers J. T., Delalle I., Baur J. A., Sui G., Armour S. M., Puigserver P., Sinclair D. A. and Tsai L. H. (2007)

SIRT1 deacetylase protects against neurodegeneration in models for Alzheimer's disease and amyotrophic lateral sclerosis. *EMBO J.* **26**, 3169-3179.

Kitada T., Asakawa S., Hattori N., Matsumine H., Yamamura Y., Minoshima S., Yokochi M., Mizuno Y. and Shimizu N. (1998) Mutations in the parkin gene cause autosomal recessive juvenile parkinsonism. *Nature* **392**, 605-608.

Klinge C. M., Blankenship K. A., Risinger K. E., Bhatnagar S., Noisin E. L., Sumanasekera W. K., Zhao L., Brey D. M. and Keynton R. S. (2005) RSV and estradiol rapidly activate MAPK signaling through estrogen receptors alpha and beta in endothelial cells. *J. Biol. Chem.* **280**, 7460-7468.

Knutti D., Kaul A. and Kralli A. (2000) A tissue-specific coactivator of steroid receptors, identified in a functional genetic screen. *Mol. Cell Biol.* **20**, 2411-2422.

Kopin I. J. and Markey S. P. (1988) MPTP toxicity: implications for research in Parkinson's disease. *Annu. Rev. Neurosci.* **11**, 81-96.

Korhonen L., Belluardo N. and Lindholm D. (2001) Regulation of X-chromosome-linked inhibitor of apoptosis protein in kainic acid-induced neuronal death in the rat hippocampus. *Mol. Cell Neurosci.* **17**, 364-372.

Kraytsberg Y., Kudryavtseva E., McKee A. C., Geula C., Kowall N. W. and Khrapko K. (2006) Mitochondrial DNA deletions are abundant and cause functional impairment in aged human substantia nigra neurons. *Nat. Genet.* **38**, 518-520.

Kuiper G. G., Lemmen J. G., Carlsson B., Corton J. C., Safe S. H., van der Saag P. T., van der B. B. and Gustafsson J. A. (1998) Interaction of estrogenic chemicals and phytoestrogens with estrogen receptor beta. *Endocrinology* **139**, 4252-4263.

Laflamme N., Nappi R. E., Drolet G., Labrie C. and Rivest S. (1998) Expression and neuropeptidergic characterization of estrogen receptors (ERalpha and ERbeta) throughout the rat brain: anatomical evidence of distinct roles of each subtype. *J. Neurobiol.* **36**, 357-378.

Lagouge M., Argmann C., Gerhart-Hines Z., Meziane H., Lerin C., Daussin F., Messadeq N., Milne J., Lambert P., Elliott P., Geny B., Laakso M., Puigserver P. and Auwerx J. (2006) RSV improves mitochondrial function and protects against metabolic disease by activating SIRT1 and PGC-1alpha. *Cell* **127**, 1109-1122.

Langston J. W. and Irwin I. (1986) MPTP: current concepts and controversies. *Clin. Neuropharmacol.* **9**, 485-507.

Langston J. W., Irwin I., Langston E. B. and Forno L. S. (1984) 1-Methyl-4-phenylpyridinium ion (MPP+): identification of a metabolite of MPTP, a toxin selective to the substantia nigra. *Neurosci. Lett.* **48**, 87-92.

Larsson N. G., Wang J., Wilhelmsson H., Oldfors A., Rustin P., Lewandoski M., Barsh G. S. and Clayton D. A. (1998) Mitochondrial transcription factor A is necessary for mtDNA maintenance and embryogenesis in mice. *Nat. Genet.* **18**, 231-236.

Le Saux M. and Di Paolo T. (2006) Influence of oestrogenic compounds on monoamine transporters in rat striatum. *J. Neuroendocrinol.* **18**, 25-32.

- Leonard S. S., Xia C., Jiang B. H., Stinefelt B., Klandorf H., Harris G. K. and Shi X. (2003) RSV scavenges reactive oxygen species and effects radical-induced cellular responses. *Biochem. Biophys. Res. Commun.* **309**, 1017-1026.
- Lerin C., Rodgers J. T., Kalume D. E., Kim S. H., Pandey A. and Puigserver P. (2006) GCN5 acetyltransferase complex controls glucose metabolism through transcriptional repression of PGC-1alpha. *Cell Metab* **3**, 429-438.
- Lin J., Tarr P. T., Yang R., Rhee J., Puigserver P., Newgard C. B. and Spiegelman B. M. (2003) PGC-1beta in the regulation of hepatic glucose and energy metabolism. *J. Biol. Chem.* **278**, 30843-30848.
- Lin J., Wu P. H., Tarr P. T., Lindenberg K. S., St-Pierre J., Zhang C. Y., Mootha V. K., Jager S., Vianna C. R., Reznick R. M., Cui L., Manieri M., Donovan M. X., Wu Z., Cooper M. P., Fan M. C., Rohas L. M., Zavacki A. M., Cinti S., Shulman G. I., Lowell B. B., Krainc D. and Spiegelman B. M. (2004) Defects in adaptive energy metabolism with CNS-linked hyperactivity in PGC-1alpha null mice. *Cell* **119**, 121-135.
- Liou H. H., Tsai M. C., Chen C. J., Jeng J. S., Chang Y. C., Chen S. Y. and Chen R. C. (1997) Environmental risk factors and Parkinson's disease: a case-control study in Taiwan. *Neurology* **48**, 1583-1588.
- Liu Y., Fiskum G. and Schubert D. (2002) Generation of reactive oxygen species by the mitochondrial electron transport chain. *J. Neurochem.* **80**, 780-787.
- Loh K. P., Huang S. H., De S. R., Tan B. K. and Zhu Y. Z. (2006) Oxidative stress: apoptosis in neuronal injury. *Curr. Alzheimer Res.* **3**, 327-337.
- Losa G. A. (2003) RSV modulates apoptosis and oxidation in human blood mononuclear cells. *Eur. J. Clin. Invest* **33**, 818-823.
- Lu K. T., Ko M. C., Chen B. Y., Huang J. C., Hsieh C. W., Lee M. C., Chiou R. Y., Wung B. S., Peng C. H. and Yang Y. L. (2008) Neuroprotective effects of RSV on MPTP-induced neuron loss mediated by free radical scavenging. *J. Agric. Food Chem.* **56**, 6910-6913.
- Lu Z., Xu X., Hu X., Fassett J., Zhu G., Tao Y., Li J., Huang Y., Zhang P., Zhao B. and Chen Y. (2010) PGC-1 alpha regulates expression of myocardial mitochondrial antioxidants and myocardial oxidative stress after chronic systolic overload. *Antioxid. Redox. Signal.* **13**, 1011-1022.
- Martin A. R., Villegas I., Sanchez-Hidalgo M. and de la Lastra C. A. (2006) The effects of RSV, a phytoalexin derived from red wines, on chronic inflammation induced in an experimentally induced colitis model. *Br. J. Pharmacol.* **147**, 873-885.
- Martinez J. and Moreno J. J. (2000) Effect of RSV, a natural polyphenolic compound, on reactive oxygen species and prostaglandin production. *Biochem. Pharmacol.* **59**, 865-870.
- Matthews R. T., Ferrante R. J., Klivenyi P., Yang L., Klein A. M., Mueller G., Kaddurah-Daouk R. and Beal M. F. (1999) Creatine and cyclocreatine attenuate MPTP neurotoxicity. *Exp. Neurol.* **157**, 142-149.

- Mazzio E. A. and Soliman K. F. (2004) Effects of enhancing mitochondrial oxidative phosphorylation with reducing equivalents and ubiquinone on 1-methyl-4-phenylpyridinium toxicity and complex I-IV damage in neuroblastoma cells. *Biochem. Pharmacol.* **67**, 1167-1184.
- McGill J. K. and Beal M. F. (2006) PGC-1alpha, a new therapeutic target in Huntington's disease? *Cell* **127**, 465-468.
- Miller L. R., Mukherjee S., Ansah T. A. and Das S. K. (2007) Cigarette smoke and dopaminergic system. *J. Biochem. Mol. Toxicol.* **21**, 325-335.
- Monsalve M., Wu Z., Adelmant G., Puigserver P., Fan M. and Spiegelman B. M. (2000) Direct coupling of transcription and mRNA processing through the thermogenic coactivator PGC-1. *Mol. Cell* **6**, 307-316.
- Mootha V. K., Handschin C., Arlow D., Xie X., St Pierre J., Sihag S., Yang W., Altshuler D., Puigserver P., Patterson N., Willy P. J., Schulman I. G., Heyman R. A., Lander E. S. and Spiegelman B. M. (2004) Erralpha and Gabpa/b specify PGC-1alpha-dependent oxidative phosphorylation gene expression that is altered in diabetic muscle. *Proc. Natl. Acad. Sci. U. S. A* **101**, 6570-6575.
- Morel I., Lescoat G., Cogrel P., Sergent O., Padeloup N., Brissot P., Cillard P. and Cillard J. (1993) Antioxidant and iron-chelating activities of the flavonoids catechin, quercetin and diosmetin on iron-loaded rat hepatocyte cultures. *Biochem. Pharmacol.* **45**, 13-19.
- Morissette M. and Di P. T. (1993) Effect of chronic estradiol and progesterone treatments of ovariectomized rats on brain dopamine uptake sites. *J. Neurochem.* **60**, 1876-1883.
- Mueller S. O., Simon S., Chae K., Metzler M. and Korach K. S. (2004) Phytoestrogens and their human metabolites show distinct agonistic and antagonistic properties on estrogen receptor alpha (ERalpha) and ERbeta in human cells. *Toxicol. Sci.* **80**, 14-25.
- Murray H. E., Pillai A. V., McArthur S. R., Razvi N., Datla K. P., Dexter D. T. and Gillies G. E. (2003) Dose- and sex-dependent effects of the neurotoxin 6-hydroxydopamine on the nigrostriatal dopaminergic pathway of adult rats: differential actions of estrogen in males and females. *Neuroscience* **116**, 213-222.
- Mytilineou C. and Cohen G. (1985) Deprenyl protects dopamine neurons from the neurotoxic effect of 1-methyl-4-phenylpyridinium ion. *J. Neurochem.* **45**, 1951-1953.
- Nanjo F., Goto K., Seto R., Suzuki M., Sakai M. and Hara Y. (1996) Scavenging effects of tea catechins and their derivatives on 1,1-diphenyl-2-picrylhydrazyl radical. *Free Radic. Biol. Med.* **21**, 895-902.
- Nicklas W. J., Vyas I. and Heikkila R. E. (1985) Inhibition of NADH-linked oxidation in brain mitochondria by 1-methyl-4-phenyl-pyridine, a metabolite of the neurotoxin, 1-methyl-4-phenyl-1,2,5,6-tetrahydropyridine. *Life Sci.* **36**, 2503-2508.
- Nicklas W. J., Youngster S. K., Kindt M. V. and Heikkila R. E. (1987) MPTP, MPP+ and mitochondrial function. *Life Sci.* **40**, 721-729.

Oakley A. E., Collingwood J. F., Dobson J., Love G., Perrott H. R., Edwardson J. A., Elstner M. and Morris C. M. (2007) Individual dopaminergic neurons show raised iron levels in Parkinson disease. *Neurology* **68**, 1820-1825.

Ogawa N., Tanaka K., Asanuma M., Kawai M., Masumizu T., Kohno M. and Mori A. (1994) Bromocriptine protects mice against 6-hydroxydopamine and scavenges hydroxyl free radicals in vitro. *Brain Res.* **657**, 207-213.

Okawara M., Katsuki H., Kurimoto E., Shibata H., Kume T. and Akaike A. (2007) RSV protects dopaminergic neurons in midbrain slice culture from multiple insults. *Biochem. Pharmacol.* **73**, 550-560.

Olanow C. W. (2002) The role of dopamine agonists in the treatment of early Parkinson's disease. *Neurology* **58**, S33-S41.

Paisan-Ruiz C., Jain S., Evans E. W., Gilks W. P., Simon J., van der Brug M., Lopez de M. A., Aparicio S., Gil A. M., Khan N., Johnson J., Martinez J. R., Nicholl D., Carrera I. M., Pena A. S., De S. R., Lees A., Marti-Masso J. F., Perez-Tur J., Wood N. W. and Singleton A. B. (2004) Cloning of the gene containing mutations that cause PARK8-linked Parkinson's disease. *Neuron* **44**, 595-600.

Palhagen S., Heinonen E., Hagglund J., Kaugesaar T., Maki-Ikola O. and Palm R. (2006) Selegiline slows the progression of the symptoms of Parkinson disease. *Neurology* **66**, 1200-1206.

Pallas M., Casadesus G., Smith M. A., Coto-Montes A., Pelegri C., Vilaplana J. and Camins A. (2009) RSV and neurodegenerative diseases: activation of SIRT1 as the potential pathway towards neuroprotection. *Curr. Neurovasc. Res.* **6**, 70-81.

Parker A. J., Arango M., Abderrahmane S., Lambert E., Tourette C., Catoire H. and Neri C. (2005) [RSV rescues mutant polyglutamine cytotoxicity in nematode and mammalian neurons]. *Med. Sci. (Paris)* **21**, 556-557.

Pezzuto J. M. (2004) RSV: a whiff that induces a biologically specific tsunami. *Cancer Biol. Ther.* **3**, 889-890.

Phillips M., Cataneo R. N., Greenberg J., Gunawardena R. and Rahbari-Oskoui F. (2003) Increased oxidative stress in younger as well as in older humans. *Clin. Chim. Acta* **328**, 83-86.

Polymeropoulos M. H., Lavedan C., Leroy E., Ide S. E., Dehejia A., Dutra A., Pike B., Root H., Rubenstein J., Boyer R., Stenroos E. S., Chandrasekharappa S., Athanassiadou A., Papapetropoulos T., Johnson W. G., Lazzarini A. M., Duvoisin R. C., Di I. G., Golbe L. I. and Nussbaum R. L. (1997) Mutation in the alpha-synuclein gene identified in families with Parkinson's disease. *Science* **276**, 2045-2047.

Pozo-Guisado E., Lorenzo-Benayas M. J. and Fernandez-Salguero P. M. (2004) RSV modulates the phosphoinositide 3-kinase pathway through an estrogen receptor alpha-dependent mechanism: relevance in cell proliferation. *Int. J. Cancer* **109**, 167-173.

Pozzi S., Benedusi V., Maggi A. and Vegeto E. (2006) Estrogen action in neuroprotection and brain inflammation. *Ann. N. Y. Acad. Sci.* **1089**, 302-323.

Przedborski S. (2007) Neuroinflammation and Parkinson's disease. *Handb. Clin. Neurol.* **83**, 535-551.

Przedborski S., Jackson-Lewis V., Djaldetti R., Liberatore G., Vila M., Vukosavic S. and Almer G. (2000) The parkinsonian toxin MPTP: action and mechanism. *Restor. Neurol. Neurosci.* **16**, 135-142.

Przedborski S., Jackson-Lewis V., Naini A. B., Jakowec M., Petzinger G., Miller R. and Akram M. (2001) The parkinsonian toxin 1-methyl-4-phenyl-1,2,3,6-tetrahydropyridine (MPTP): a technical review of its utility and safety. *J. Neurochem.* **76**, 1265-1274.

Puigserver P., Adelmant G., Wu Z., Fan M., Xu J., O'Malley B. and Spiegelman B. M. (1999) Activation of PPARgamma coactivator-1 through transcription factor docking. *Science* **286**, 1368-1371.

Puigserver P., Wu Z., Park C. W., Graves R., Wright M. and Spiegelman B. M. (1998) A cold-inducible coactivator of nuclear receptors linked to adaptive thermogenesis. *Cell* **92**, 829-839.

Qin W., Haroutunian V., Katsel P., Cardozo C. P., Ho L., Buxbaum J. D. and Pasinetti G. M. (2009) PGC-1alpha expression decreases in the Alzheimer disease brain as a function of dementia. *Arch. Neurol.* **66**, 352-361.

Qin W., Yang T., Ho L., Zhao Z., Wang J., Chen L., Zhao W., Thiyagarajan M., MacGrogan D., Rodgers J. T., Puigserver P., Sadoshima J., Deng H., Pedrini S., Gandy S., Sauve A. A. and Pasinetti G. M. (2006) Neuronal SIRT1 activation as a novel mechanism underlying the prevention of Alzheimer disease amyloid neuropathology by calorie restriction. *J. Biol. Chem.* **281**, 21745-21754.

Rajeswari A. (2006) Curcumin protects mouse brain from oxidative stress caused by 1-methyl-4-phenyl-1,2,3,6-tetrahydropyridine. *Eur. Rev. Med. Pharmacol. Sci.* **10**, 157-161.

Ramassamy C. (2006) Emerging role of polyphenolic compounds in the treatment of neurodegenerative diseases: a review of their intracellular targets. *Eur. J. Pharmacol.* **545**, 51-64.

Ramirez A. D., Liu X. and Menniti F. S. (2003) Repeated estradiol treatment prevents MPTP-induced dopamine depletion in male mice. *Neuroendocrinology* **77**, 223-231.

Rasheed A. S., Venkataraman S., Jayaveera K. N., Fazil A. M., Yasodha K. J., Aleem M. A., Mohammed M., Khaja Z., Ushasri B., Pradeep H. A. and Ibrahim M. (2010) Evaluation of toxicological and antioxidant potential of *Nardostachys jatamansi* in reversing haloperidol-induced catalepsy in rats. *Int. J. Gen. Med.* **3**, 127-136.

Raval A. P., Lin H. W., Dave K. R., DeFazio R. A., Della M. D., Kim E. J. and Perez-Pinzon M. A. (2008) RSV and ischemic preconditioning in the brain. *Curr. Med. Chem.* **15**, 1545-1551.

Reijonen S., Kukkonen J. P., Hyrskyluoto A., Kivinen J., Kairisalo M., Takei N., Lindholm D. and Korhonen L. (2010) Downregulation of NF-kappaB signaling by mutant huntingtin proteins induces oxidative stress and cell death. *Cell Mol. Life Sci.* **67**, 1929-1941.

- Robb E. L. and Stuart J. A. (2011) RSV interacts with estrogen receptor-beta to inhibit cell replicative growth and enhance stress resistance by upregulating mitochondrial superoxide dismutase. *Free Radic. Biol. Med.* **50**, 821-831.
- Rodgers J. T., Lerin C., Haas W., Gygi S. P., Spiegelman B. M. and Puigserver P. (2005) Nutrient control of glucose homeostasis through a complex of PGC-1alpha and SIRT1. *Nature* **434**, 113-118.
- Roediger B. and Armati P. J. (2003) Oxidative stress induces axonal beading in cultured human brain tissue. *Neurobiol. Dis.* **13**, 222-229.
- Ross J. R., Ramakrishnan H., Porter B. E. and Robinson M. B. (2011) Group I mGluR-regulated translation of the neuronal glutamate transporter, excitatory amino acid carrier 1. *J. Neurochem.* **117**, 812-823.
- Ruderman N. B., Xu X. J., Nelson L., Cacicedo J. M., Saha A. K., Lan F. and Ido Y. (2010) AMPK and SIRT1: a long-standing partnership? *Am. J. Physiol Endocrinol. Metab* **298**, E751-E760.
- Sakata Y., Zhuang H., Kwansa H., Koehler R. C. and Dore S. (2010) RSV protects against experimental stroke: putative neuroprotective role of heme oxygenase 1. *Exp. Neurol.* **224**, 325-329.
- Scarpulla R. C. (2002a) Nuclear activators and coactivators in mammalian mitochondrial biogenesis. *Biochim. Biophys. Acta* **1576**, 1-14.
- Scarpulla R. C. (2002b) Transcriptional activators and coactivators in the nuclear control of mitochondrial function in mammalian cells. *Gene* **286**, 81-89.
- Schapira A., Bate G. and Kirkpatrick P. (2005) Rasagiline. *Nat. Rev. Drug Discov.* **4**, 625-626.
- Schapira A. H. (2007) Mitochondrial dysfunction in Parkinson's disease. *Cell Death. Differ.* **14**, 1261-1266.
- Schapira A. H. (2008) Progress in neuroprotection in Parkinson's disease. *Eur. J. Neurol.* **15 Suppl 1**, 5-13.
- Schapira A. H., Agid Y., Barone P., Jenner P., Lemke M. R., Poewe W., Rascol O., Reichmann H. and Tolosa E. (2009) Perspectives on recent advances in the understanding and treatment of Parkinson's disease. *Eur. J. Neurol.* **16**, 1090-1099.
- Schober A. (2004) Classic toxin-induced animal models of Parkinson's disease: 6-OHDA and MPTP. *Cell Tissue Res.* **318**, 215-224.
- Schreiber S. N., Emter R., Hock M. B., Knutti D., Cardenas J., Podvinec M., Oakeley E. J. and Kralli A. (2004) The estrogen-related receptor alpha (ERRalpha) functions in PPARgamma coactivator 1alpha (PGC-1alpha)-induced mitochondrial biogenesis. *Proc. Natl. Acad. Sci. U. S. A* **101**, 6472-6477.
- Sechi G. P., Agnetti V., Piredda M., Canu M., Deserra F., Omar H. A. and Rosati G. (1992) Acute and persistent parkinsonism after use of diquat. *Neurology* **42**, 261-263.

Sevcsik E., Trexler A. J., Dunn J. M. and Rhoades E. (2011) Allosterity in a disordered protein: oxidative modifications to alpha-synuclein act distally to regulate membrane binding. *J. Am. Chem. Soc.* **133**, 7152-7158.

Shinde S. and Pasupathy K. (2006) Respiratory-chain enzyme activities in isolated mitochondria of lymphocytes from patients with Parkinson's disease: preliminary study. *Neurol. India* **54**, 390-393.

Shughrue P. J., Lane M. V. and Merchenthaler I. (1997) Comparative distribution of estrogen receptor-alpha and -beta mRNA in the rat central nervous system. *J. Comp Neurol.* **388**, 507-525.

Shulman L. M. (2007) Gender differences in Parkinson's disease. *Gend. Med.* **4**, 8-18.

Shults C. W. (2006) Lewy bodies. *Proc. Natl. Acad. Sci. U. S. A* **103**, 1661-1668.

Skaper S. D., Floreani M., Ceccon M., Facci L. and Giusti P. (1999) Excitotoxicity, oxidative stress, and the neuroprotective potential of melatonin. *Ann. N. Y. Acad. Sci.* **890**, 107-118.

Sokka A. L., Putkonen N., Mudo G., Pryazhnikov E., Reijonen S., Khiroug L., Belluardo N., Lindholm D. and Korhonen L. (2007) Endoplasmic reticulum stress inhibition protects against excitotoxic neuronal injury in the rat brain. *J. Neurosci.* **27**, 901-908.

Son J. H., Chun H. S., Joh T. H., Cho S., Conti B. and Lee J. W. (1999) Neuroprotection and neuronal differentiation studies using substantia nigra dopaminergic cells derived from transgenic mouse embryos. *J. Neurosci.* **19**, 10-20.

Soobrattee M. A., Neergheen V. S., Luximon-Ramma A., Aruoma O. I. and Bahorun T. (2005) Phenolics as potential antioxidant therapeutic agents: mechanism and actions. *Mutat. Res.* **579**, 200-213.

Speer O., Morkunaite-Haimi S., Liobikas J., Franck M., Hensbo L., Linder M. D., Kinnunen P. K., Wallimann T. and Eriksson O. (2003) Rapid suppression of mitochondrial permeability transition by methylglyoxal. Role of reversible arginine modification. *J. Biol. Chem.* **278**, 34757-34763.

Spina M. B. and Cohen G. (1988) Exposure of striatal [corrected] synaptosomes to L-dopa increases levels of oxidized glutathione. *J. Pharmacol. Exp. Ther.* **247**, 502-507.

St-Pierre J., Drori S., Uldry M., Silvaggi J. M., Rhee J., Jager S., Handschin C., Zheng K., Lin J., Yang W., Simon D. K., Bachoo R. and Spiegelman B. M. (2006) Suppression of reactive oxygen species and neurodegeneration by the PGC-1 transcriptional coactivators. *Cell* **127**, 397-408.

Sulzer D., Bogulavsky J., Larsen K. E., Behr G., Karatekin E., Kleinman M. H., Turro N., Krantz D., Edwards R. H., Greene L. A. and Zecca L. (2000) Neuromelanin biosynthesis is driven by excess cytosolic catecholamines not accumulated by synaptic vesicles. *Proc. Natl. Acad. Sci. U. S. A* **97**, 11869-11874.

Sun A. Y., Wang Q., Simonyi A. and Sun G. Y. (2010) RSV as a therapeutic agent for neurodegenerative diseases. *Mol. Neurobiol.* **41**, 375-383.

Tatton W. G., Chalmers-Redman R. M., Ju W. J., Mammen M., Carlile G. W., Pong A. W. and Tatton N. A. (2002) Propargylamines induce antiapoptotic new protein synthesis in serum- and nerve growth factor (NGF)-withdrawn, NGF-differentiated PC-12 cells. *J. Pharmacol. Exp. Ther.* **301**, 753-764.

Thomas B. and Beal M. F. (2007) Parkinson's disease. *Hum. Mol. Genet.* **16 Spec No. 2**, R183-R194.

Trapp T., Korhonen L., Besselmann M., Martinez R., Mercer E. A. and Lindholm D. (2003) Transgenic mice overexpressing XIAP in neurons show better outcome after transient cerebral ischemia. *Mol. Cell Neurosci.* **23**, 302-313.

Tyynismaa H., Carroll C. J., Raimundo N., Ahola-Erkkila S., Wenz T., Ruhanen H., Guse K., Hemminki A., Peltola-Mjosund K. E., Tulkki V., Oresic M., Moraes C. T., Pietilainen K., Hovatta I. and Suomalainen A. (2010) Mitochondrial myopathy induces a starvation-like response. *Hum. Mol. Genet.* **19**, 3948-3958.

Ubeda A., Montesinos C., Paya M. and Alcaraz M. J. (1993) Iron-reducing and free-radical-scavenging properties of apomorphine and some related benzyloisoquinolines. *Free Radic. Biol. Med.* **15**, 159-167.

Um J. H., Park S. J., Kang H., Yang S., Foretz M., McBurney M. W., Kim M. K., Violette B. and Chung J. H. (2010) AMP-activated protein kinase-deficient mice are resistant to the metabolic effects of RSV. *Diabetes* **59**, 554-563.

Valente E. M., Abou-Sleiman P. M., Caputo V., Muqit M. M., Harvey K., Gispert S., Ali Z., Del T. D., Bentivoglio A. R., Healy D. G., Albanese A., Nussbaum R., Gonzalez-Maldonado R., Deller T., Salvi S., Cortelli P., Gilks W. P., Latchman D. S., Harvey R. J., Dallapiccola B., Auburger G. and Wood N. W. (2004) Hereditary early-onset Parkinson's disease caused by mutations in PINK1. *Science* **304**, 1158-1160.

Vila M. and Przedborski S. (2004) Genetic clues to the pathogenesis of Parkinson's disease. *Nat. Med.* **10 Suppl**, S58-S62.

Vingtdeux V., Giliberto L., Zhao H., Chandakkar P., Wu Q., Simon J. E., Janle E. M., Lobo J., Ferruzzi M. G., Davies P. and Marambaud P. (2010) AMP-activated protein kinase signaling activation by RSV modulates amyloid-beta peptide metabolism. *J. Biol. Chem.* **285**, 9100-9113.

Waldmeier P. C., Boulton A. A., Cools A. R., Kato A. C. and Tatton W. G. (2000) Neurorescuing effects of the GAPDH ligand CGP 3466B. *J. Neural Transm. Suppl* 197-214.

Wallberg A. E., Yamamura S., Malik S., Spiegelman B. M. and Roeder R. G. (2003) Coordination of p300-mediated chromatin remodeling and TRAP/mediator function through coactivator PGC-1alpha. *Mol. Cell* **12**, 1137-1149.

Wang H. Q. and Takahashi R. (2007) Expanding insights on the involvement of endoplasmic reticulum stress in Parkinson's disease. *Antioxid. Redox. Signal.* **9**, 553-561.

Wang J., Ho L., Zhao Z., Seror I., Humala N., Dickstein D. L., Thiyagarajan M., Percival S. S., Talcott S. T. and Pasinetti G. M. (2006) Moderate consumption of Cabernet

Sauvignon attenuates Abeta neuropathology in a mouse model of Alzheimer's disease. *FASEB J.* **20**, 2313-2320.

Wang X., Zaidi A., Pal R., Garrett A. S., Braceras R., Chen X. W., Michaelis M. L. and Michaelis E. K. (2009) Genomic and biochemical approaches in the discovery of mechanisms for selective neuronal vulnerability to oxidative stress. *BMC. Neurosci.* **10**, 12.

Wang X., Zhu C., Wang X., Hagberg H., Korhonen L., Sandberg M., Lindholm D. and Blomgren K. (2004) X-linked inhibitor of apoptosis (XIAP) protein protects against caspase activation and tissue loss after neonatal hypoxia-ischemia. *Neurobiol. Dis.* **16**, 179-189.

Wareski P., Vaarmann A., Choubey V., Safiulina D., Liiv J., Kuum M. and Kaasik A. (2009) PGC-1 α and PGC-1 β regulate mitochondrial density in neurons. *J. Biol. Chem.* **284**, 21379-21385.

Weydt P., Pineda V. V., Torrence A. E., Libby R. T., Satterfield T. F., Lazarowski E. R., Gilbert M. L., Morton G. J., Bammler T. K., Strand A. D., Cui L., Beyer R. P., Easley C. N., Smith A. C., Krainc D., Luquet S., Sweet I. R., Schwartz M. W. and La Spada A. R. (2006) Thermoregulatory and metabolic defects in Huntington's disease transgenic mice implicate PGC-1 α in Huntington's disease neurodegeneration. *Cell Metab* **4**, 349-362.

Wootz H., Hansson I., Korhonen L. and Lindholm D. (2006) XIAP decreases caspase-12 cleavage and calpain activity in spinal cord of ALS transgenic mice. *Exp. Cell Res.* **312**, 1890-1898.

Wu F., Khan S., Wu Q., Barhoumi R., Burghardt R. and Safe S. (2008) Ligand structure-dependent activation of estrogen receptor α /Sp by estrogens and xenoestrogens. *J. Steroid Biochem. Mol. Biol.* **110**, 104-115.

Wu R. M., Chen R. C. and Chiueh C. C. (2000) Effect of MAO-B inhibitors on MPP⁺ toxicity in Vivo. *Ann. N. Y. Acad. Sci.* **899**, 255-261.

Wu Z., Puigserver P., Andersson U., Zhang C., Adelmant G., Mootha V., Troy A., Cinti S., Lowell B., Scarpulla R. C. and Spiegelman B. M. (1999) Mechanisms controlling mitochondrial biogenesis and respiration through the thermogenic coactivator PGC-1. *Cell* **98**, 115-124.

Wu Z., Xu Q., Zhang L., Kong D., Ma R. and Wang L. (2009) Protective effect of RSV against kainate-induced temporal lobe epilepsy in rats. *Neurochem. Res.* **34**, 1393-1400.

Yamamoto F., Ohgari Y., Yamaki N., Kitajima S., Shimokawa O., Matsui H. and Taketani S. (2007) The role of nitric oxide in delta-aminolevulinic acid (ALA)-induced photosensitivity of cancerous cells. *Biochem. Biophys. Res. Commun.* **353**, 541-546.

Yen G. C., Duh P. D. and Lin C. W. (2003) Effects of RSV and 4-hexylresorcinol on hydrogen peroxide-induced oxidative DNA damage in human lymphocytes. *Free Radic. Res.* **37**, 509-514.

Yokoyama H., Takagi S., Watanabe Y., Kato H. and Araki T. (2008) Role of reactive nitrogen and reactive oxygen species against MPTP neurotoxicity in mice. *J. Neural Transm.* **115**, 831-842.

Yoshioka M., Tanaka K., Miyazaki I., Fujita N., Higashi Y., Asanuma M. and Ogawa N. (2002) The dopamine agonist cabergoline provides neuroprotection by activation of the glutathione system and scavenging free radicals. *Neurosci. Res.* **43**, 259-267.

Youdim M. B., Wadia A., Tatton W. and Weinstock M. (2001) The anti-Parkinson drug rasagiline and its cholinesterase inhibitor derivatives exert neuroprotection unrelated to MAO inhibition in cell culture and in vivo. *Ann. N. Y. Acad. Sci.* **939**, 450-458.

Zhang J. Q., Cai W. Q., Zhou D. S. and Su B. Y. (2002) Distribution and differences of estrogen receptor beta immunoreactivity in the brain of adult male and female rats. *Brain Res.* **935**, 73-80.

Zheng B., Liao Z., Locascio J. J., Lesniak K. A., Roderick S. S., Watt M. L., Eklund A. C., Zhang-James Y., Kim P. D., Hauser M. A., Grunblatt E., Moran L. B., Mandel S. A., Riederer P., Miller R. M., Federoff H. J., Wullner U., Papapetropoulos S., Youdim M. B., Cantuti-Castelvetri I., Young A. B., Vance J. M., Davis R. L., Hedreen J. C., Adler C. H., Beach T. G., Graeber M. B., Middleton F. A., Rochet J. C. and Scherzer C. R. (2010) PGC-1alpha, a potential therapeutic target for early intervention in Parkinson's disease. *Sci. Transl. Med.* **2**, 52ra73.

Zhou C., Huang Y. and Przedborski S. (2008) Oxidative stress in Parkinson's disease: a mechanism of pathogenic and therapeutic significance. *Ann. N. Y. Acad. Sci.* **1147**, 93-104.

Zhu C., Xu F., Fukuda A., Wang X., Fukuda H., Korhonen L., Hagberg H., Lannering B., Nilsson M., Eriksson P. S., Northington F. J., Bjork-Eriksson T., Lindholm D. and Blomgren K. (2007) X chromosome-linked inhibitor of apoptosis protein reduces oxidative stress after cerebral irradiation or hypoxia-ischemia through up-regulation of mitochondrial antioxidants. *Eur. J. Neurosci.* **26**, 3402-3410.

Zimprich A., Biskup S., Leitner P., Lichtner P., Farrer M., Lincoln S., Kachergus J., Hulihan M., Uitti R. J., Calne D. B., Stoessl A. J., Pfeiffer R. F., Patenge N., Carbajal I. C., Vieregge P., Asmus F., Muller-Myhsok B., Dickson D. W., Meitinger T., Strom T. M., Wszolek Z. K. and Gasser T. (2004) Mutations in LRRK2 cause autosomal-dominant parkinsonism with pleomorphic pathology. *Neuron* **44**, 601-607.

Zini R., Morin C., Bertelli A., Bertelli A. A. and Tillement J. P. (1999) Effects of RSV on the rat brain respiratory chain. *Drugs Exp. Clin. Res.* **25**, 87-97.