

**Nationaal Lucht- en Ruimtevaartlaboratorium**

National Aerospace Laboratory NLR



NLR-TP-2003-536

## **Multi-agent situation awareness error evolution in accident risk modelling**

S.H. Stroeve, H.A.P. Blom, M.N.J. van der Park



NLR-TP-2003-536

## Multi-agent situation awareness error evolution in accident risk modelling

S.H. Stroeve, H.A.P. Blom, M.N.J. van der Park

This report contains a paper presented at the 5th USA/Europe Air Traffic Management R&D Seminar, at Budapest, Hungary on 23-27 June 2003; the paper received the “Best paper Award for Quality Research in the area of Safety” from the scientific committee.

The contents of this report may be cited on condition that full credit is given to NLR and the authors.

Customer: National Aerospace Laboratory NLR  
Working Plan number: I.1.A.2  
Owner: National Aerospace Laboratory NLR  
Division: Air Transport  
Distribution: Unlimited  
Classification title: Unclassified  
November 2003

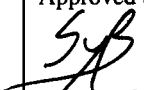
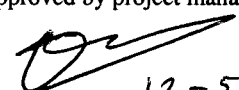
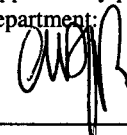
Approved by author:  12-5-04	Approved by project manager:  12-5-04	Approved by project managing department:  13-5-04
---	---	---



## **Summary**

A mathematical model is presented for the evolution of situation awareness within the context of human performance modelling in accident risk assessment for ATM. Various aspects of situation awareness are defined within a group of agents, such as human operators and technical systems. Application of the model is illustrated for an accident risk assessment of an active runway crossing operation.



## **Contents**

<b>1</b>	<b>Introduction</b>	<b>5</b>
<b>2</b>	<b>An active runway crossing operation</b>	<b>8</b>
<b>3</b>	<b>Multiple agents in the model</b>	<b>10</b>
<b>4</b>	<b>Modelling situation awareness</b>	<b>12</b>
<b>5</b>	<b>Integration of situation awareness with other human performance models</b>	<b>15</b>
<b>6</b>	<b>Accident risk model</b>	<b>17</b>
<b>7</b>	<b>Preliminary risk results for the active runway crossing operation model</b>	<b>18</b>
<b>8</b>	<b>Concluding remarks</b>	<b>20</b>
<b>9</b>	<b>References</b>	<b>21</b>
	<b>Appendix A Mathematical representation of multi-agent situation awareness</b>	<b>22</b>
	<b>Appendix B List of symbols</b>	<b>24</b>

(25 pages in total)



## 1 Introduction

Since capacity and efficiency are the drivers of the development of advanced air traffic operations, by now there is a broad consensus that appropriate accident risk assessment models are needed to assess safety in relation to capacity with the aim to optimise advanced air traffic operations [1], [2], [3]. Air traffic operations account for highly distributed interactions between human operators, procedures and technical systems. As such, the safety of an air traffic operation depends not only on the functioning of its individual elements, but also on their complex interactions, especially in non-nominal situations. Because of this distributed control nature of air traffic, established techniques fall short in performing accident risk assessment. In [4] this problem has been addressed with the development of a stochastic analysis based methodology that takes an integral approach towards accident risk assessment for air traffic.

A crucial issue in accident risk assessment for air traffic operations is the appropriate incorporation of the human factors. Hence, there is a clear need for a modelling approach to assess and understand accident risk in relation to the performance of the human operators involved. This means that appropriate human performance models are required that describe human cognitive and responsibility principles up to the level of accident risk. In [5] and [6] we have started the development of an approach for human performance modelling in accident risk assessment for air traffic management. This resulted in a successful integration of several psychological models, i.e. Wickens's Multiple Resources model [7], human error and error correction modelling [8], [9], and Hollnagel's Contextual Control Mode model [10], and a successful use of these models in accident risk assessment applications.

In the literature it is well recognised that situation awareness (SA) and the lack of or errors in SA are important contributing factors to many accidents [11], [12], [13]. Moreover, our own finding is that during hazard identification brainstorm sessions with operational experts, many of the identified hazards appear to be of SA error evolution type. In such case there is a root cause, often so minor that it goes unnoticed initially. However, the multi-agent interactions cause an evolution over time which amplifies the root cause into significant differences in the SA of the agents. In such case the SA of at least one of the agents is erroneous. Hence, in the context of accident risk assessment there exists a major interest in errors in situation awareness and the relation of these errors to accidents.

Endsley [11] defines SA as follows:

*Situation awareness is the perception of elements in the environment within a volume of time and space, the comprehension of their meaning, and the projection of their status in the near future.*



Furthermore, the process of achieving, acquiring and maintaining situation awareness is referred to as *situation assessment* [11]. Following these definitions, SA is a dynamic state of knowledge which discerns three levels:

1. perception of elements in the environment,
2. comprehension of the current situation,
3. projection of the future status.

Endsley [11] discusses errors in SA at these three levels, and clearly distinguishes incomplete SA (knowledge of only some elements) from inaccurate SA (erroneous knowledge concerning the value of some elements). At level 1, a person may wrongly or not perceive task-relevant information. This may depend on, e.g., related signal characteristics, perception strategies in complex environments and expectations. At level 2, a person may wrongly interpret perceived information. This may depend on, e.g., the miss-use or non-existence of proper mental models of the environment. At level 3, a person may wrongly predict a future status, for instance, due to lack of a good mental model or memory limitations.

In addition to these SA error categories, in a multi-agent environment such as air traffic is, one should be aware that errors in SA may evolve due to intra-agent interaction, such as communication, without erroneous perception, interpretation or prediction processes. For instance, an agent may have received erroneous or incomplete information from another agent. These types of SA errors may contribute importantly to accident risk.

Another important issue is that in air traffic there also are interactions with agents that are not human, while the SA definition provided by Endsley [11] implicitly considers environment knowledge of human agents only. Hence, for the formulation of SA in this paper we will use the concept of agent to come up with a more general group of entities that may have SA, on the one hand, and to define the environment for which SA is attained, on the other hand. An agent is an entity such as a human operator or a technical system, which may possess SA of the environment. For the definition of the environment we consider a group of agents. The environment of each agent consists of the complete group of agents.

The aim of the current paper is to extend the human performance modelling approach in quantitative accident risk assessment in [5] and [6] with a model for Multi-Agent Situation Awareness Error Evolution. Our approach has much in common with the Updateable World Representation (UWR) in MIDAS [14]. By exploiting a mathematical modelling framework it has enhanced capabilities in managing the complexity in multi-agent SA error evolution modelling.



This paper is organised as follows. Section 2 introduces the air traffic operation example for which the modelling approach will be illustrated. Section 3 discusses the agents in the air traffic operation considered. Section 4 provides a mathematical model of situation awareness and situation assessment in a group of agents. Section 5 describes the integration of the SA models with other human performance models. Section 6 presents the accident risk decomposition for the accident risk model. Section 7 provides results of this accident risk model. Concluding remarks are given in Section 8.



## 2 An active runway crossing operation

In this paper the situation awareness modelling approach will be illustrated for an active runway crossing operation. This example accounts for a considerable number of interacting agents. The runway configuration of the active runway crossing operation considered is shown in Figure 1. The configuration takes into account one runway, named Runway A, with holdings, crossings and exits. The crossings enable traffic between the aprons and a second runway, named Runway B. Each crossing has remotely controlled stopbars on both sides of the runway. Also the holdings have remotely controlled stopbars and each exit has a fixed stopbar.

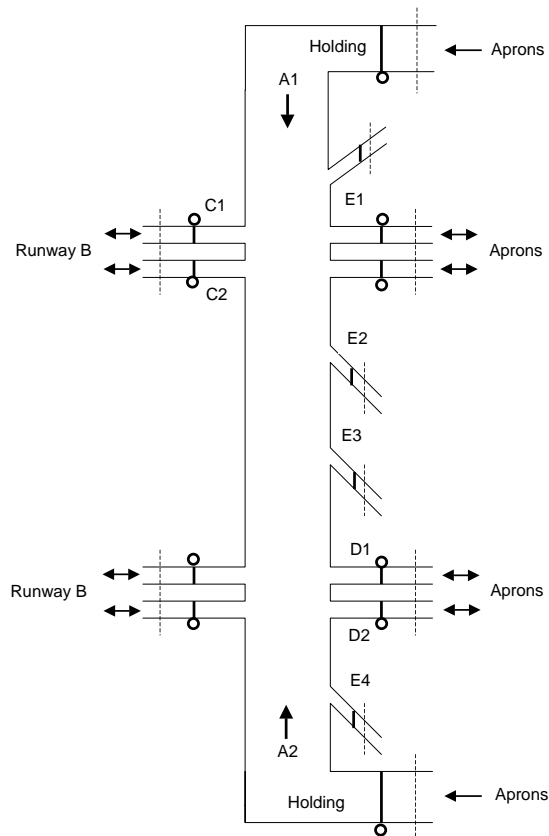

**Figure 1:** Runway configuration of active runway crossing procedure.

The involved human operators include the start-up controller, the ground controller, the Runway A controller, the Runway B controller, the departure controller, and the pilots flying and pilots not flying of taking off aircraft and crossing aircraft. The active runway crossing operation is considered under good visibility condition only, enabling pilots and controllers to monitor the traffic situation via direct visual observation.





Communication between controllers and aircraft crews is via standard VHF R/T. Communication between controllers is supported by telephone lines. Monitoring by the controllers can be by direct visual observation and is supported by radar track plots. The Runway A controller is supported by a runway incursion alert system and a stopbar violation alert system. The Runway A controller manages the remotely controlled stopbars and the runway lighting. Monitoring by the aircraft crews is by visual observation and is supported by the VHF R/T party-line effect.

In the runway crossing operation considered, the control over the crossing aircraft is transferred from the ground controller or the Runway B controller (depending on the direction of the runway crossing) to the Runway A controller. If the Runway A controller is aware that the runway is not used for a take-off, the crew of an aircraft intending to cross is cleared to do so and the remotely controlled stopbar is switched off. The Pilot-Not-Flying of the crossing aircraft acknowledges the clearance and then the Pilot-Flying initiates the runway crossing. When the crossing aircraft has vacated the runway, then the Pilot-Not-Flying reports this to the Runway A Controller. Next the control over the aircraft is transferred from the Runway A controller to either the Runway B controller or the ground controller.

### 3 Multiple agents in the model

The model for the active runway crossing operation described in Section 2 includes the following agents (see also Figure 2), where an agent is an entity that has elements of a situation awareness model as defined in Section 4:

- aircraft (taking off or taxiing),
- aircraft's flight management systems (FMS),
- pilots flying (PF's),
- pilots not flying (PNF's),
- Runway A controller,
- Runway B controller,
- ground controller,
- departure controller,
- start-up controller,
- ATC system, which is broadly defined to include:
  - airport manoeuvre control systems,
  - surveillance systems,
  - airport configuration,
  - environmental conditions,
  - communication systems.

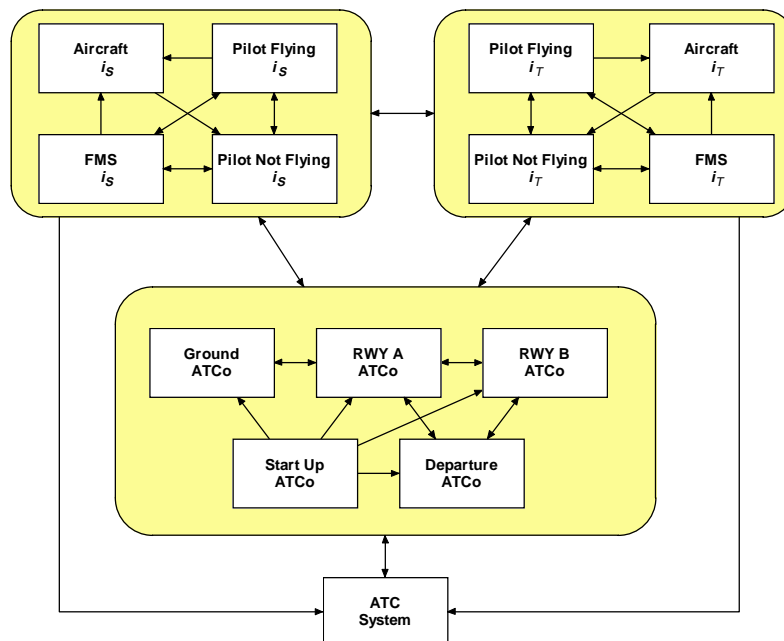

**Figure 2:** Relations between agents identified for the active runway crossing operation. The index  $i_s$  denotes an aircraft starting (taking off) from runway A and the index  $i_T$  denotes an aircraft taxiing across Runway A.



Prior to the development of a quantitative accident risk model, for the active runway crossing operation considered a qualitative accident risk assessment has been performed. It follows from this qualitative study that of all identified conflict scenarios, there are three conflict scenarios which may pose unacceptable safety effects. In this paper, we focus on the details of a quantitative accident risk model for one of these conflict scenarios. In this conflict scenario there is one aircraft that takes off and has been allowed to do so and there is one aircraft that crosses the runway while it should not. The visibility conditions are assumed to be good. Taxiing along a straight line over one of the standard runway crossings (i.e., via C1, C2, D1 or D2 in Figure 1) is considered. Hence, in the illustrative example of this paper, emphasis is placed on the models of the aircraft, pilot flying, Runway A controller and ATC system agents.

### **Aircraft**

A taking-off aircraft initiates take-off from a position at the beginning of the runway. A crossing aircraft initiates crossing at a position close to the remotely controlled stopbar with a normal taxiing speed or from a hold state.

### **Pilot flying of taking off aircraft**

Initially, the pilot flying (PF) of a taking off aircraft has the SA that take-off is allowed and initiates a take-off. During the take-off the PF monitors the traffic situation on the runway visually and via the VHF communication channel. The PF starts a collision avoidance braking action if a crossing aircraft is observed within a critical distance from the runway centre-line or in reaction to an ATCo clearance, and it is decided that braking will stop the aircraft in front of the crossing aircraft.

### **Pilot flying of crossing aircraft**

Initially, the PF has the intent SA that the next airport way-point is either a regular taxiway or a runway crossing. In the former case the PF proceeds taxiing and in the latter case the PF may have the SA that crossing is allowed. The characteristics of the visual monitoring process of the PF depend on the intent SA. In case of awareness of a conflict, either due to own visual observation or due to an ATCo call, the PF stops the aircraft, unless it is already within a critical distance from the runway centre-line.

### **Runway A controller**

The Runway A controller visually monitors the traffic and has support from a stopbar violation alert and a runway incursion alert. If the ATCo is aware that a crossing aircraft has passed the stopbar, a hold clearance is specified to both the crossing and the taking off aircraft.

### **ATC system**

The ATC system includes communication systems, tracking systems, a stopbar violation alert, a runway incursion alert and remotely controlled stopbars.



#### 4 Modelling situation awareness

A general mathematical representation for the situation awareness (SA) of agent  $k$  at time  $t$  consists of a column of SA subprocesses:

$$\sigma_{t,k} = \begin{pmatrix} \overset{1}{i}_{t,k} \\ \overset{1}{x}_{t,k} \\ \overset{1}{\theta}_{t,k} \\ \overset{1}{v}_{t,k} \end{pmatrix},$$

with the following SA components:

- $\overset{1}{i}_{t,k}$  denotes the awareness by agent  $k$  at time  $t$  of the identity of other agents. For example, it may represent the awareness of a pilot concerning the identity code of a nearby aircraft.
- $\overset{1}{x}_{t,k}$  denotes the awareness by agent  $k$  at time  $t$  of continuous-valued state components of other agents. For example, it may represent the awareness by a runway controller of the position and velocity of an aircraft.
- $\overset{1}{\theta}_{t,k}$  denotes the awareness by agent  $k$  at time  $t$  of discrete-valued state components (modes) of other agents. For example, it may represent the awareness of an air traffic controller of mode of an alert.
- $\overset{1}{v}_{t,k}$  denotes the awareness by agent  $k$  at time  $t$  of the intent of other agents. The intent  $\overset{1}{v}_{t,k}$  has various elements, which represent the anticipation by agent  $k$  at time  $t$  of modes and continuous states of other agents, and related times at which these modes or continuous states are expected to be achieved. These elements are fully specified in Appendix A. For example, it may represent the expectations by a runway controller of the mode of an aircraft (e.g., ‘ground run’, ‘hold’, ‘airborne’), a way-point of an aircraft and the passage time of a way-point by an aircraft.

Each component of  $\sigma_{t,k}$  may take values in its normal state space enlarged with  $\{\}$ , representing an unknown. The first three components of the SA column (i.e., all but the intent) is named ‘state SA’. The fourth component is named ‘intent SA’.

##### Situation assessment

Achieving, acquiring and maintaining situation awareness is a dynamic process, which is sometimes referred to as situation assessment [11]. In the current paper this dynamic process is mathematically formulated by considering, firstly, a number of types of SA updating processes and, secondly, an SA updating scheduling process, which specifies the times at which the SA becomes updated. The application of situation assessment processes for the active runway crossing accident risk model, including the relation other human performance models will be presented in Section 5.



### SA updating

The following updating processes for the situation awareness of an agent are considered:

1. observation,
2. communication, and
3. reasoning.

Implications of these processes for the update of SA components are discussed in the following paragraphs.

#### Observation

An update of the SA of agent  $k$  via observation can be represented by an observation mapping  $f_k^{\text{obs}}(\cdot)$ :

$$\sigma_{t,k} = f_k^{\text{obs}}(\sigma_{t^-,k}, i_t, x_t, \theta_t, \varepsilon_{t,k}),$$

where  $t^-$  denotes the time just before the update,  $i_t$  is the actual identity of an observed agent,  $x_t$  is the actual continuous state of an observed agent,  $\theta_t$  is the actual mode of an observed agent and  $\varepsilon_{t,k}$  represents stochastic effects that may influence the observation process. The variable  $\varepsilon_{t,k}$  may, for instance, be assumed to depend on noise, perception errors and the cognitive mode of a human operator.

#### Communication

An update of the SA of agent  $k_1$  via communication with agent  $k_2$  can be represented by a communication mapping  $f_{k_1,k_2}^{\text{com}}(\cdot)$ :

$$\sigma_{t,k_1} = f_{k_1,k_2}^{\text{com}}(\sigma_{t^-,k_1}, \sigma_{t,k_2}, \varepsilon_{t,k_1,k_2}),$$

which states that the update of situation awareness of agent  $k_1$  is depends on the previous SA of agent  $k_1$ , on the SA of agent  $k_2$  and on a stochastic variable  $\varepsilon_{t,k_1,k_2}$ , which may, e.g., be assumed to depend on noise and the cognitive mode of the human operators involved.

#### Reasoning

An update of SA of agent  $k$  via reasoning can be represented by a reasoning mapping  $f_k^{\text{rea}}(\cdot)$ :

$$\sigma_{t,k} = f_k^{\text{rea}}(\sigma_{t^-,k}, \varepsilon_{t,k}),$$

which only depends on the previous SA and a stochastic component  $\varepsilon_{t,k}$ .

### SA update scheduling

The SA updating scheduling process determines the times at which the SA is updated by one of the SA updating processes. This scheduling process may vary considerably for various types of agents. In general, the SA updating scheduling process can be seen as part of the overall task scheduling process.



A high-level representation of the task scheduling process of an agent can be represented by the combination of a task triggering process and a task scheduling process. The task triggering process for task  $q$  of agent  $k$  specifies times when it is desired to complete the task:

$$t_{k,q}^{\text{trigger}} = f_{k,q}^{\text{trigger}}(\sigma_{t,k}, \eta_{t,k}),$$

and may depend of the SA of the agent and other agent specific variables  $\eta_{t,k}$ . The task scheduling process specifies times at which the SA may be updated as a result of task  $q$ :

$$t_{k,q}^{\text{update}} = f_k^{\text{sched}}(\sigma_{t,k}, t_{k,q}^{\text{trigger}}, \eta_{t,k}),$$

and may depend on the SA of the agent, the task triggering times and other agent specific variables  $\eta_{t,k}$  (e.g., cognitive mode, task processing behaviour).

## 5 Integration of situation awareness with other human performance models

In this section we will describe how the elements of the SA modelling approach are included in the human operators' models for the agents of the active runway crossing operation and how these SA models interact with other cognitive performance models of the human operators considered.

The development of the human operator models is based on the situation awareness modelling approach presented in the previous sections and the human cognition modelling methods presented in [5].

Specifically, for a human operator

- £ a decomposition of the tasks of the human operator is identified,
- £ the most essential cognitive control modes are identified,
- £ the characteristics of the operator tasks are identified for the most important cognitive control modes,
- £ clusters of tasks are identified,
- £ hierarchy and concurrency for the task clusters are identified.

These model development steps, including the situation awareness representation, give rise to a model structure that is similar for each of the human operators. As an illustrative example, we will use the model of the pilot flying of an aircraft that taxis towards the runway crossing. A high-level overview of the model elements of the pilot flying agent is shown in Figure 3.

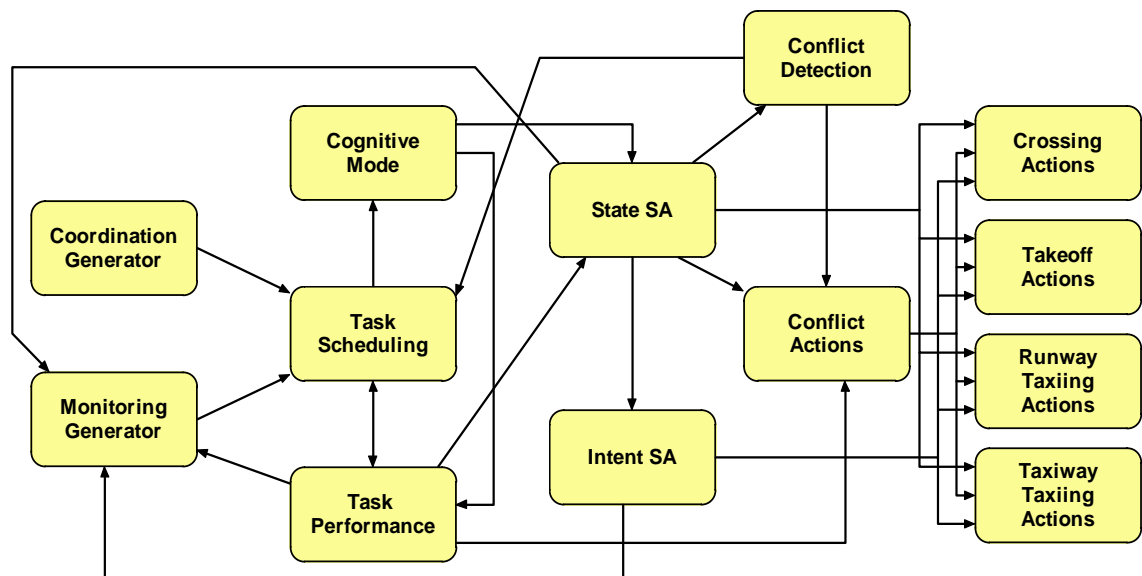

Figure 3: High-level overview of the model elements of the pilot flying agent.



The human operator models include the following groups of model elements.

#### Task triggering

Task triggering processes specify times at which it is desired to complete a task. They may depend on other processes, such as task performance and situation awareness. For example, the model blocks *Monitoring Generator* and *Coordination Generator* in Figure 3 represent task triggering processes of a PF and specify times at which monitoring of the traffic situation and coordination with the PNF is desired, respectively. These model blocks receive several inputs. For instance, the dependence of *Monitoring Generator* from *Intent SA* enables an intent-dependent visual updating frequency.

#### Task scheduling

Task scheduling processes determine which tasks should currently be processed by the human operator. Task scheduling processes may depend on other processes, e.g., task triggering, task performance and situation awareness processes. For example, in Figure 3 the *Task Scheduling* block represents a scheduling process with a fixed hierarchy and concurrency structure.

#### Task performance

Task performance processes describe the development of the progress of a task. They may, e.g., depend on task scheduling and cognitive mode processes. For example, in Figure 3 the *Task Performance* block depends on the *Cognitive Mode* block, resulting in a faster task performance in the opportunistic control mode with respect to the tactical control mode of the pilot flying.

#### Cognitive control mode

Cognitive control mode processes describe the cognitive control mode of the human operator. They may, e.g., depend on the number and types of scheduled tasks. See, for instance, the *Cognitive Mode* block in Figure 3.

#### Situation awareness

Situation awareness model elements represent the state SA and intent SA, as outlined in Section 4. In Figure 3, the model blocks *State SA*, *Intent SA* and *Conflict Detection* represent SA components. Here, the *Conflict Detection* block represents the detection process and the SA of a conflict. In Figure 3, the *State SA* block depends on the *Cognitive Mode* block, representing that (errors in) the state SA updating process can depend on the cognitive mode.

#### Task specific actions

Task specific actions represent particular elements of tasks of a human operator. For instance, for a pilot flying these may include (see Figure 3) *Crossing Actions*, *Takeoff Actions*, *Runway Taxiing Actions*, *Taxiway Taxiing Actions* and *Conflict Actions*.



## 6 Accident risk model

For the conflict scenario considered, an accident risk model has been developed represents using the mathematical modelling formalism of Dynamically Coloured Petri Nets [14]. It represents nominal and non-nominal behaviour of the agents discussed. In the present model version most emphasis is placed on the models of the aircraft, pilot flying, Runway A controller and ATC system agents [16].

Furthermore, an accident risk decomposition has been developed in [16], which is required to efficiently evaluate the collision risk and to promote insight in the risk contributions. The evaluation of the collision risk is based on the probabilities and the conditional collision risks of combinations of event sequences, as have been identified in the decomposition process. The decomposition process considers whether alert systems, remotely controlled stopbar and communication systems are functioning well or not. In particular, the decomposition process considers

- the aircraft type of each aircraft to be either a medium-weight Airbus *A320* or a heavy-weight Boeing *747*;
- the intent SA of the PF of a crossing aircraft concerning the next way-point (*Taxiway / Crossing*) and concerning allowance of runway crossing (*Allowed / Not Allowed*);
- whether alert systems are functioning well or not;
- whether the remotely controlled stopbar is functioning well or not;
- whether communication systems are functioning well or not.

The present version of the model of the active runway crossing procedure accounts for intent-dependent and cognitive mode-dependent error-prone perception processes of pilots flying and the Runway A controller. Table 1 shows how a number of situation awareness related hazards of the operation considered were accounted for in the quantitative accident risk model.

*Table 1: Examples of the representation of SA related hazards in the accident risk model of the active runway crossing procedure.*

SA hazard	Model representation
Runway incursion alert is active, but runway controller has wrong ‘picture’ of the situation, and therefore reacts too late, not or wrongly.	In response to an alert there is a chance that the runway controller does not observe the conflict and therefore does not react.
Pilots get confused because of complexity of the taxiways in the new operation.	The PF of a taxiing aircraft may be aware that the aircraft is taxiing on a regular taxiway while it actually is on a runway crossing.
Pilot reacts not, wrongly, too late or cannot react to conflict solving clearance of runway controller.	There is a chance that the PF does not or only after a long time becomes aware of a clearance.



## 7 Preliminary risk results for the active runway crossing operation model

Using the detailed mathematical formulation of the accident risk model for the active runway crossing procedure [16], of which elements have been introduced in Section 3, Monte Carlo simulation software was developed to evaluate the conditional collision risk for the events resulting from the decomposition process. Some initial results of the model are presented in this section. They have a preliminary status, because the model has not been reviewed by operational experts and a bias and uncertainty assessment [17] for the model results remains to be done.

Table 2 provides collision risk results for a crossing distance of 1000 m from the runway threshold. It specifies the total collision risk as well as risk contributions for certain events. It follows from Table 2 that events for which the PF of a crossing aircraft has the intent SA to proceed on a regular taxiway rather than a runway crossing contribute largely (92.1%). Furthermore, it follows from Table 2 that (non-nominal) events in which alerting systems or communication systems are not functioning well, hardly contribute to the accident risk. It implies that the failure probabilities of these systems may be extensively larger before they will make a significant contribution to the accident risk.

*Table 2: Initial results of the accident risk model for the active runway crossing procedure. The column 'Events' specifies some event types, the column 'Risk' specifies the collision risk contribution for each event, and the last column gives the relative risk.*

Events		Risk (per take-off)	Relative risk
All		$1.1 \cdot 10^{-8}$	100%
Intent PF taxiing a/c	<i>Taxiway</i>	$1.0 \cdot 10^{-8}$	92.1%
	<i>Crossing</i>	$8.8 \cdot 10^{-10}$	7.9%
Alerting systems	<i>Up</i>	$1.1 \cdot 10^{-8}$	99.99%
	<i>Down</i>	$5.7 \cdot 10^{-13}$	0.0052%
Comm. systems	<i>Up</i>	$1.1 \cdot 10^{-8}$	99.99%
	<i>Down</i>	$1.4 \cdot 10^{-12}$	0.012%

In the model, the accident risk is dominated by events which are nominal, except for the intent SA of the PF of the crossing aircraft regarding the next airport way-point. The events that are nominal concern the remotely controlled stopbar (*On*), the alerting systems of the runway controller (*Working*), ATC communication systems (*Up*) and aircraft type (Airbus *A320* or Boeing *747*). In Table 3 probability metrics are gathered for event groups  $K_{\text{taxiway}}^{\text{nominal}}$  and  $K_{\text{crossing}}^{\text{nominal}}$  of runway crossings while all events are nominal and with the intent SA of the PF of



the crossing aircraft regarding the next way-point being either *Taxiway* or *Crossing*, respectively. It follows from Table 3 that the large contribution from events with the intent SA being *Taxiway* is due to the largely enhanced conditional collision risk for this situation by about a factor 73, rather due to the event probability, which is about a factor 5.7 smaller. The enhanced conditional collision risk for the situation considered is due to the intent SA adapted monitoring process of the PF of the crossing aircraft.

*Table 3: Probability metrics for two main groups of events contributing to the accident risk. The probabilities are specified as occurrence per take-off and are initial model results.*

Probability metric	Event combinations	
	$K_{\text{taxiway}}^{\text{nominal}}$	$K_{\text{crossing}}^{\text{nominal}}$
Event condition	$3.5 \cdot 10^{-5}$	$2.0 \cdot 10^{-4}$
Conditional collision risk	$2.9 \cdot 10^{-4}$	$4.0 \cdot 10^{-6}$
Collision risk	$1.0 \cdot 10^{-8}$	$8.0 \cdot 10^{-10}$
Contr. to total collision risk	92.1 %	7.1 %

The effect on conflict resolution of the various human operators can be determined in the model. Table 4 shows estimates of conflict resolution probabilities of the pilots of both aircraft together and of the runway controller. It follows that for the operation considered the pilots contribute largely to successful conflict resolution, where the success rate is strongly determined by the intent SA of the PF of the crossing aircraft. A remarkable result from the model is (see Table 4), that the runway controller on average hardly contributes to conflict resolution in addition to the conflicts detected and resolved by the pilots themselves.

*Table 4: Conflict resolution probabilities (initial results) of involved human operators for some conditions.*

Human operators	Condition	Conflict resolution probability
Pilots of both aircraft	Intent = <i>Taxiway</i>	0.996
Pilots of both aircraft	Intent = <i>Crossing</i>	0.99997
Runway controller	Conflict not resolved by pilots	0.15



## **8 Concluding remarks**

We have developed a mathematical model for situation awareness and situation assessment in a multi-agent environment. The development of this framework was stimulated by our recognition that situation awareness errors evolution in a multi-agent environment plays a key role in ATM accident risk models.

The components of the mathematical SA representation account for a multi-agent environment, are time-dependent and include agent identity, continuous state variables, mode variables and intent variables. Here, an agent may represent a human operator or a technical system, leading to an enhanced definition of entities that may have SA. Given the SA components, for each agent it may represent the perceived and interpreted status (continuous-valued state and mode variables) and the status in the near future (intent variables). Thus it can account for the SA elements in the definition of Endsley [11], which was given in Section 1. Naturally, the exact definition of the SA subprocesses depends on the application at hand.

The feasibility of this framework has been illustrated for an accident risk model of an active runway crossing operation. This example accounts for a considerable number of interacting agents. The preliminary results obtained indicate that the situation awareness model can be combined well with other human performance models, and that the intent-dependent situation assessment process of the pilot flying of a crossing aircraft has a major effect on the accident risk.

### **Acknowledgements**

The authors would like to thank Kevin Corker (San Jose State University, CA) for very helpful discussions on SA error evolution modelling. This research has been supported by the European Commission within the OPAL project and by ATAC Corporation (CA) within the NASA System-wide Safety Modelling project.



## 9 References

- [1] Haraldsdottir A, Schwab RW, Alcabin MS. Air Traffic Management Capacity Driven Operational Concept Through 2015. In: Donohue GL and Zellweger AG (eds.), *Air Transp. Systems Eng.*, AIAA, pp. 9-25, 2001
- [2] Odoni AR et al. *Existing and required modelling capabilities for evaluating ATM systems and concepts*. Report MIT, 1997.
- [3] Wickens CD, Mavor AS, Parasuraman R, McGee JP (eds.). *The future of Air Traffic Control, Human Operators and Automation*. National Academy Press, Washington DC, 1998.
- [4] Blom HAP, Bakker GJ, Blanker PJG, Daams J, Everdij MHC, Klompstra MB. Accident risk assessment for advanced air traffic management. In: Donohue GL and Zellweger AG (eds.), *Air Transp. Systems Eng.*, AIAA, pp. 463-480, 2001. (Also published as NLR-TP-2001-642)
- [5] Blom HAP, Daams J, Nijhuis HB. Human cognition modelling in ATM safety assessment. In: Donohue GL and Zellweger AG (eds.), *Air Transp. Systems Eng.*, AIAA, pp. 481-511, 2001. (Also published as NLR-TP-2001-636)
- [6] Blom HAP, Stroeve SH, Everdij MHC, Van der Park MNJ. Human cognition performance model to evaluate safe spacing in air traffic. *Human Factors and Aerospace Safety*, 3(1): 59-82, 2003. (Also published as NLR-TP-2002-690)
- [7] Wickens CR. *Engineering, Psychology and Human Performance*. Columbus: Merrill, 1992.
- [8] Kirwan B. *A guide to practical human reliability assessment*. Taylor and Francis, 1994.
- [9] Amalberti R, Wioland L. Human error in aviation. In Soekkha H (ed.), *Aviation Safety*, pp. 91-108, 1997.
- [10] Hollnagel E. *Human reliability analysis, context and control*. Academic Press, London, 1993.
- [11] Endsley MR. Towards a theory of situation awareness in dynamic systems. *Human Factors*, 37(1): 32-64, 1995.
- [12] ESSAI project team. Orientation on situation awareness and crisis management. National Aerospace Laboratory NLR, Report NLR-TR-2000-668, 2000.
- [13] Rodgers MD, Mogford RH, Strauch B. Post hoc assessment of situation awareness in air traffic control incidents and major aircraft accidents. In: Endsley MR, Garland DJ (eds.), *Situation Awareness Analysis and Measurement*, Lawrence Erlbaum Associates, Mahwah, New Jersey, 2000.
- [14] Laughery K, Corker K. Computer modeling and simulation. In: Salvendy G (ed.), *Handbook of Human Factors*, pp. 1375-1408, 1997.
- [15] Everdij MHC, Blom HAP. *Piecewise deterministic Markov processes represented by Dynamically Coloured Petri Nets*. National Aerospace Laboratory NLR, report NLR-TP-2000-428, 2000.
- [16] Stroeve SH, Van der Park MNJ, Blom HAP, Klompstra MB, Bakker GJ. *Accident risk assessment model for active runway crossing procedure*. National Aerospace Laboratory NLR, report NLR-TR-2001-527, NLR Company Confidential, 2002.
- [17] Everdij MHC, Blom HAP. *Bias and uncertainty in accident risk assessment*. National Aerospace Laboratory NLR, report NLR-TR-2002-137, 2002.



## Appendix A Mathematical representation of multi-agent situation awareness

### SA in a group of multiple agents

To complete the definition of SA in a group of agents we specify the identity of an agent by a pair of indices  $(h,i)$  or  $(l,j)$ . The first element of each index pair ( $h$  or  $l$ ) indicates the type of the agent and the second element of each index pair ( $i$  or  $j$ ) indicates a (serial) number or code of the agent. For example, in the context of ATM,  $h$  or  $l$  may be ‘pilot flying’, ‘aircraft’ or ‘air traffic controller’, and  $i$  or  $j$  may be an aircraft’s call-sign if the agent type is aircraft or pilot flying, and type of controller (e.g., ‘runway’, ‘departure’, ‘start-up’) if the agent is an air traffic controller.

Using these indices, the situation awareness held by an agent  $k \equiv (l,j)$  at time  $t$  concerning an agent  $(h,i)$  is given by the column of SA subprocesses:

$$\sigma_{t,l,j}^{h,i} = \begin{matrix} \textcircled{P} \\ \textcircled{C} \\ \textcircled{X} \\ \textcircled{1} \\ \textcircled{\theta} \\ \textcircled{1} \\ \textcircled{TM} \end{matrix} \begin{matrix} h,i \\ t,l,j \\ h,i \\ t,l,j \\ h,i \\ t,l,j \\ h,i \\ t,l,j \end{matrix} \Bigg| .$$

### Intent SA

The intent SA  $\bar{v}_{t,l,j}^{h,i}$  is represented by a matrix that consists of a number of ordered columns of intent SA subprocesses  $(\bar{v}_{t,l,j}^{h,i})_p$ :

$$(\bar{v}_{t,l,j}^{h,i})_p = \begin{matrix} \textcircled{P} \\ \textcircled{C} \\ \textcircled{X} \\ \textcircled{1} \\ \textcircled{TM} \end{matrix} \begin{matrix} h,i \\ t,l,j \\ h,i \\ t,l,j \\ h,i \\ t,l,j \end{matrix} \Bigg|_p .$$

The elements of the intent SA matrix represent the following aspects.

- $(\bar{\theta}_{t,l,j}^{h,i})_p$  denotes a mode of agent  $(h,i)$  that is anticipated by agent  $(l,j)$ . For example, it may represent the expectation of the mode of the aircraft (e.g., ‘ground run’, ‘hold’, ‘airborne’) by a runway controller.
- $(\bar{x}_{t,l,j}^{h,i})_p$  denotes a continuous-valued state component of agent  $(h,i)$  that is anticipated by agent  $(l,j)$ . For example, it may represent the expectation of a way-point of an aircraft by a runway controller.
- $(\bar{t}_{t,l,j}^{h,i})_p$  denotes the expectation of agent  $(l,j)$ , held at time  $t$ , concerning the time at which the continuous-valued state component  $(\bar{x}_{t,l,j}^{h,i})_p$  will be attained, or the expectation of the time up to which the mode  $(\bar{\theta}_{t,l,j}^{h,i})_p$  will be attained by agent  $(h,i)$ . For example, it may represent the expectation by a controller of the passage time of a way-point by an aircraft.



For a more precise definition for the relation between the intent SA components a stopping time  $(\tau_{l,j}^{h,i})_p$  is used.

If  $(\bar{x}_{t,l,j}^{h,i})_p$  is specified, then

$$(\tau_{l,j}^{h,i})_p = \inf(t; \bar{x}_{t,l,j}^{h,i} = \bar{x}_{t,l,j}^{h,i}),$$

$$(\hat{t}_{t,l,j}^{h,i})_p = (\tau_{l,j}^{h,i})_p,$$

else (i.e., if  $(\bar{x}_{t,l,j}^{h,i})_p = \{\}$ )

$$(\tau_{l,j}^{h,i})_p = (\hat{t}_{t,l,j}^{h,i})_p.$$

Using this stopping time, the intent SA for the mode of agent  $(h,i)$  now is

$$\bar{\theta}_{t,l,j}^{h,i} = (\bar{\theta}_{t,l,j}^{h,i})_p \quad \text{for } (\tau_{l,j}^{h,i})_{p-1} \leq t < (\tau_{l,j}^{h,i})_p.$$

For example, in the context of ATM, a pilot flying of an aircraft who intends to subsequently taxi over a taxiway segment  $T1$ , taxi via a runway crossing  $C1$ , taxi towards a runway holding  $H1$  and take-off at a time  $t_{\text{take-off}}$  may have the following intent:

$$\bar{v}_{l,j}^{h,i} = \left. \begin{array}{cccc} \text{Ⓢ taxi} & \text{taxi} & \text{taxi} & \text{take - off} \\ \text{Ⓢ T1} & C1 & H1 & \{\} \\ \text{Ⓢ } \{\} & \{\} & \{\} & t_{\text{take-off}} \end{array} \right\}.$$



## Appendix B List of symbols

$f_{k_1, k_2}^{\text{com}}(\cdot)$	Mapping describing situation awareness update of agent $k_1$ via communication with agent $k_2$ .
$f_k^{\text{obs}}(\cdot)$	Mapping describing situation awareness update of agent $k$ via observation.
$f_k^{\text{rea}}(\cdot)$	Mapping describing situation awareness update of agent $k$ via reasoning.
$f_k^{\text{sched}}(\cdot)$	Mapping specifying the situation awareness updating time of agent $k$ as the result of the completion of a task.
$f_{k, q}^{\text{trigger}}(\cdot)$	Mapping specifying the desired completion time of task $q$ by agent $k$ .
$i_t$	Actual identity of an agent
$\overset{1}{i}_{t, k}$	Awareness by agent $k$ at time $t$ of the identity of other agents.
$\overset{1}{i}_{t, l, j}^{h, i}$	Awareness by agent $(l, j)$ at time $t$ of the identity of agent $(h, i)$ .
$t^-$	Time just before update of situation awareness.
$t_{k, q}^{\text{trigger}}$	Desired completion time of task $q$ by agent $k$ .
$t_{k, q}^{\text{update}}$	Situation awareness updating time of agent $k$ as a result of the completion of task $q$ .
$(\overset{1}{t}_{l, j}^{h, i})_p$	Expectation of agent $(l, j)$ concerning the time at which the continuous-valued state component $(\bar{x}_{l, j}^{h, i})_p$ will be attained, or the expectation of the time up to which the mode $(\bar{\theta}_{l, j}^{h, i})_p$ will be attained by agent $(h, i)$ .
$x_t$	Actual continuous-valued state component of an agent.
$\overset{1}{x}_{t, k}$	Awareness by agent $k$ at time $t$ of continuous-valued state components of other agents.
$\overset{1}{x}_{t, l, j}^{h, i}$	Awareness by agent $(l, j)$ at time $t$ of continuous-valued state component of agent $(h, i)$ .
$(\bar{x}_{l, j}^{h, i})_p$	Continuous-valued state component of agent $(h, i)$ that is anticipated by agent $(l, j)$ .
$\mathcal{E}_{t, k}$	Stochastic contribution in update of situation awareness by agent $k$ via observation or reasoning.
$\mathcal{E}_{t, k_1, k_2}$	Stochastic contribution in update of situation awareness by agent $k_1$ via communication with agent $k_2$ .
$\eta_{t, k}$	Agent $k$ specific variables that influence agent task triggering and task scheduling processes.
$\theta_t$	Actual mode of an agent.
$\overset{1}{\theta}_{t, k}$	Awareness by agent $k$ at time $t$ of modes of other agents.
$\overset{1}{\theta}_{t, l, j}^{h, i}$	Awareness by agent $(l, j)$ at time $t$ of modes of agent $(h, i)$ .





$(\bar{\theta}_{l,j}^{h,i})_p$	Mode of agent $(h,i)$ that is anticipated by agent $(l,j)$ .
$\sigma_{t,k}$	Situation awareness of agent $k$ at time $t$ .
$\sigma_{t,l,j}^{h,i}$	Situation awareness of agent $(l, j)$ at time $t$ concerning agent $(h,i)$
$(\tau_{l,j}^{h,i})_p$	Stopping time for the definition of the situation awareness of agent $(l,j)$ concerning the $p^{\text{th}}$ mode or way-point intended by agent $(h,i)$ .
$\hat{v}_{t,k}$	Awareness by agent $k$ at time $t$ of the intent of other agents.
$\hat{v}_{t,l,j}^{h,i}$	Awareness by agent $(l,j)$ at time $t$ of the intent of agent $(h,i)$ .