



## Executive summary

# Dutch helicopter-ship qualification - Ready for the future



### **Problem area**

Within the next few years the Netherlands Ministry of Defence will not only introduce the NH90 NFH and marinized TTH on their existing ships, but will also introduce three more classes of helicopter carrying ships.

### **Description of work**

The National Aerospace Laboratory NLR has 40 years of experience in the field of helicopter-ship qualification testing. A cost effective and safe approach has been developed in the course of time, based on a thorough understanding of the helicopter (shore-based) operational characteristics and the ship's environment.

To be able to efficiently and safely perform the large amount of upcoming qualification programmes, NLR has upgraded their ship and helicopter instrumentation package, as well as data processing and presentation facilities in the past few years.

Furthermore, pilot-in-the-loop simulation is introduced parallel to the qualification process to develop a simulation capacity aimed at supporting the current SHOL (Ship Helicopter Operational Limitation) determination process in the future. Besides a description of the proven qualification process, this paper describes the recent developments in ship and helicopter instrumentation package, data processing and presentation facilities. Furthermore, the

### **Report no.**

NLR-TP-2006-568

### **Author(s)**

P.J.A. Booij  
J.F. Hakkaart  
A.J. Striegel  
J. van der Vorst

### **Classification report**

Unclassified

### **Date**

October 2006

### **Knowledge area(s)**

Helicopter technology  
Flight tests

### **Descriptor(s)**

helicopter  
ship  
instrumentation  
flight trials

This report is based on a presentation held at the 32<sup>nd</sup> European Rotorcraft Forum, Maastricht (the Netherlands), 12-14 September 2006.

introduction of pilot-in-the-loop simulation in the qualification process is discussed briefly.

### **Results and conclusions**

The new instrumentation, data processing and presentation facilities were proven to be valuable in several test campaigns in 2005 and will continue to be enhanced in the future.

It is expected that pilot-in-the-loop simulation will be a valuable contribution in both the determination of the candidate flight envelope as well as the evaluation of the flight test results.



NLR-TP-2006-568

## Dutch helicopter-ship qualification - Ready for the future

P.J.A. Booij, J.F. Hakkaart, A.J. Striegel and J. van der Vorst



This report is based on a presentation held at the 32<sup>nd</sup> European Rotorcraft Forum, Maastricht (the Netherlands), 12-14 September 2006.

The contents of this report may be cited on condition that full credit is given to NLR and the authors.

This publication has been refereed by the Advisory Committee AEROSPACE VEHICLES.

Customer	National Aerospace Laboratory NLR
Contract number	----
Owner	National Aerospace Laboratory NLR
Division	Aerospace Vehicles
Distribution	Unlimited
Classification of title	Unclassified
	September 2007

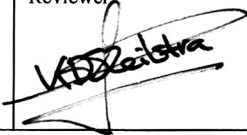
Approved by:

Author 	Reviewer 	Managing department 
-----------------------------------------------------------------------------------------------	-------------------------------------------------------------------------------------------------	--------------------------------------------------------------------------------------------------------------



## Summary

Within the next few years the Netherlands Ministry of Defence will not only introduce the NH90 NFH and maritized TTH on their existing ships, but will also introduce three more classes of helicopter carrying ships.

The National Aerospace Laboratory NLR - the Netherlands has 40 years of experience in the field of helicopter-ship qualification testing. A cost effective and safe approach has been developed in the course of time, based on a thorough understanding of the helicopter (shore-based) operational characteristics and the ship's environment.

To be able to efficiently and safely perform the large amount of upcoming qualification processes, NLR has enhanced their instrumentation package, data processing and presentation facilities.

Besides a description of the proven qualification process, this report describes the recent developments in ship and helicopter instrumentation package, data processing and presentation facilities. Furthermore, the introduction of pilot-in-the-loop simulation in the qualification process is discussed briefly.



## Contents

<b>1</b>	<b>Introduction</b>	<b>9</b>
<b>2</b>	<b>Experience</b>	<b>12</b>
<b>3</b>	<b>Qualification programme</b>	<b>13</b>
3.1	General	13
3.2	Environment	15
3.2.1	Wind tunnel tests on a scale model of the ship	15
3.2.2	Full-scale ship's wind climate and motion tests	16
3.2.3	Instrumentation	17
3.3	Helicopter - shore based hover trials	18
3.3.1	Instrumentation	20
3.4	Candidate flight envelope	21
3.5	Helicopter qualification flight testing on board a ship	24
3.5.1	Test programme	24
3.5.2	Test execution	28
3.5.3	Post processing	29
3.5.4	Usage of test results	30
3.5.5	Measured parameters	31
3.5.6	Instrumentation	32
3.5.6.1	Mobile test centre	33
3.5.6.2	Telemetry receiving system	34
3.5.6.3	Telemetry ground station	35
3.5.6.4	Video camera	35
3.6	Drafting SHOLs/Constructing Wind Envelopes	36
<b>4</b>	<b>Introduction of simulation in qualification programme</b>	<b>37</b>
<b>5</b>	<b>Concluding Remarks</b>	<b>39</b>
<b>6</b>	<b>References</b>	<b>40</b>

## Abbreviations

A/F	Aft/Fore
AFS	Advanced Flight Simulator
AGL	Above Ground Level
AUM	helicopter All-Up Mass
CC	Command & Control Centre [UK: Opsroom; USA:Combat Information Centre]
F/A	Fore/Aft
FDO	Flight Deck Officer
GIS	Generic Instrumentation System
GPI	Glide Path Indicator
GSI	Glide Slope Indicator
HCO	Helicopter Control Officer
HEDAS	Helicopter Data Acquisition System
HIFR	Helicopter In Flight Refuelling
HPS	Helicopter Pilot Station
IGE	In Ground Effect (hover)
JLSS	Joint Logistic Support Ship
LPD	Landing Platform Dock
M	helicopter Mass
MAUM	Maximum All Up Mass
NFH	Nato Frigate Helicopter
NLR	Nationaal Lucht- en Ruimtevaartlaboratorium (National Aerospace Laboratory NLR - the Netherlands)
NVG	Night Vision Goggles
OAT	Outside Air Temperature
o/b	on board
OGE	Out of Ground Effect (hover)
OPV	Offshore Patrol Vessel
PC	Personal Computer
PD	Project Definition
RMDU	Remote Multiplexing/Digitizer Unit
RMS	Root Mean Square
RNLAF	Royal Netherlands Air Force
RNLN	Royal Netherlands Navy

ROSDIS	ROtorcraft Ship Dynamic Interface Simulation
RRR	Rotors Running Refuelling
RW	Relative Wind
SHOLs	Ship Helicopter Operational Limitations
TTH	Tactical Transport Helicopter
UVW	Orthogonal velocity components of a local wind velocity vector
Vertrep	Vertical replenishment
WAU	Wind data Acquisition Unit
XD	Cross Deck
$\sigma_d$	Air density ratio



## 1 Introduction

Within the next few years the Netherlands Ministry of Defence will not only introduce the NH90 NFH and maritized TTH on their existing helicopter carrying ships, but will also introduce three more classes of helicopter carrying ships.

At this moment, the Royal Netherlands Naval Air Service consists of one command, the group MARitime HELicopters (MARHELI), consisting of two squadrons, VGSQ 7 and VGSQ 860. Both squadrons are equipped with the upgraded Lynx SH-14D helicopter and are based at Naval Air Station “De Kooy”. The Lynx helicopters will be replaced by 12 NH90 NATO Frigate Helicopters starting in December 2007.

In December 2007 the first of 20 NH90 helicopters (Fig. 1) will arrive, which are ordered in two versions: 12 NATO Frigate Helicopters (NH90 NFH) and 8 Maritized Tactical Transport Helicopters (NH90 MTTH ). They will be placed under the new “Defensie Helikopter Commando” (Defence Helicopter Command), based at Air Force Base “Gilze-Rijen”, also the base of the MTTH version, while the NFH version will be based at Naval Air Station “De Kooy”.



*Figure 1 NH90 (source: NH Industries).*

In the fall of 2006, the second Landing Platform Dock (LPD) “Hr. Ms. Johan de Witt” of the Royal Netherlands Navy will make its maiden voyage. The ship is equipped with two landing spots and a hangar with a capacity for six NH90 helicopters. Design work has been started on two new ship classes: an Offshore Patrol Vessel (OPV) and a Joint Logistics Support Ship

(JLSS). It is expected that the first OPV will enter service in 2009 and the final unit in 2011. The OPVs will be fitted with a flight deck and hangar to support one NH-90 helicopter. The JLSS requirement is for one unit to replace the “Hr. Ms. Zuiderkruis” in 2012. The JLSS is expected to combine transport, tanker and helicopter support capabilities in one hull.

In recent years, operations with a large variety of helicopter types from various classes of naval ships have steadily increased world-wide. The improved capabilities of present-generation helicopters offer a wide range of possibilities for ship-helicopter combinations to cope with the growing demand being put on modern maritime forces. Many, even relatively small, vessels are being equipped with a helicopter flight deck.

Sometimes an almost marginal facility is provided for take-off, landing and deck handling. Yet, helicopter operations may be required in a wide range of operational conditions (day, night, sea-state, wind, visibility etc.) with the highest possible payload. Nowadays, in line with the increasing importance of helicopter/ship operations the helicopter manufacturer sometimes additionally provides limitations of a general nature for helicopter-ship operations.

The limitations for land-based operations (determined after extensive factory testing) are based amongst others on a non-moving and unobstructed landing site. On the other hand, the limitations for ship-borne operations are to be based on an obstructed landing site (flight deck) which may show random oscillatory movement and where amongst others extremely turbulent wind conditions can prevail.

Unlike land-based take-offs and landings, ship-borne take-offs and landings occur in winds from any direction relative to the helicopter. The freedom of naval ships to manoeuvre is often limited by operational constraints, thus creating relative winds in which the helicopter is forced to take off or land in non-ideal conditions.

In figure 2 a launch/recovery platform with multiple landing spots (flight deck) aboard a ship of the Royal Netherlands Navy is shown.

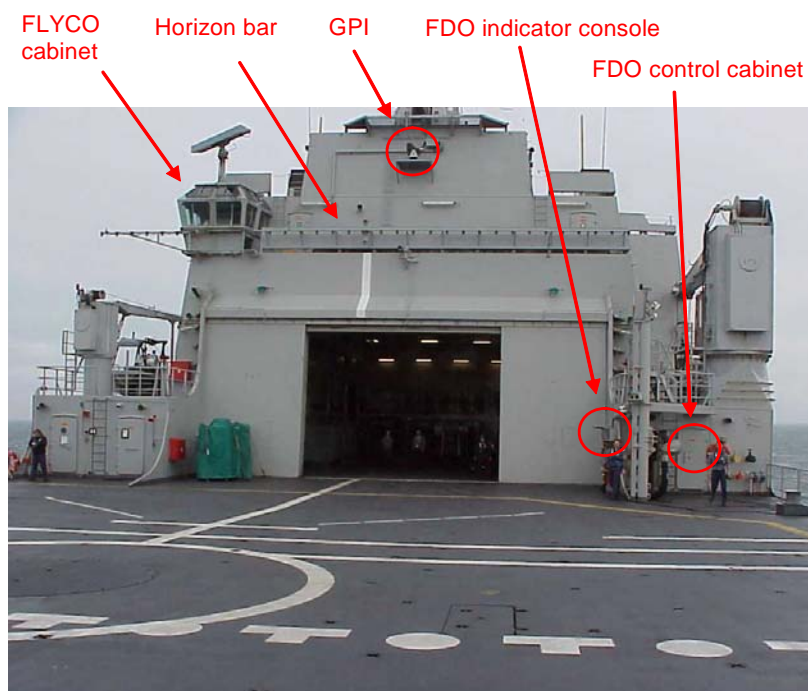

Figure 2 Flight deck and hangar lay-out on board a Royal Netherlands Navy ship.

Typical land-based helicopter platforms are normally large, flat, open spaces which are conducive to low atmospheric wind turbulence. Conversely, a ship's superstructure always creates air-wake turbulence over the flight deck and the platform attitude is never stationary. In addition, the interaction of the ambient environment (true winds and sea motion) with the ship, which creates the operational environment for the helicopter, is not the same for every class of ship.

For land-based helicopter operations, the manufacturer provides the operational limitations and procedures. These are laid down in the manuals. As the oscillations of the landing platform on a moving vessel are strongly dependent on the ships' characteristics and the operational environment, the helicopter manufacturer can only provide some general guidance for ship-borne helicopter operations. Dedicated operational limitations for ship-borne operations are therefore the responsibility of the operator.

Because of the unique characteristics of each helicopter-type/class-of-ship combination and the innumerable combinations possible, it is understandable that usually no (extensive) testing has been carried out by the helicopter manufacturer for all combinations that may be of interest. It follows that the limitations given, if any, must be considered as general guidelines, with large safety margins with respect to the helicopter capabilities and pilot ability to control the helicopter, and thus do not provide a maximum operational availability of the helicopter on board the ship. It is expected that the actual limitations, i.e. those that allow maximum

availability of the helicopter within the constraints of safety, are lying somewhere between the limitations for land-based and those for ship-borne operations as given by the manufacturer. To determine these limitations a dedicated helicopter-ship qualification programme is to be executed. Figure 3 shows an example of helicopter operations in rough weather.



*Figure 3 Helicopter operations on board a ship in a rough environment.*

In this report an explanatory overview is given of the factors influencing helicopter-ship operations, the way they are determined in various qualification programme elements and how they are used to set up a flight test programme on board a ship.

Besides a description of the proven qualification process, this report describes their recent developments in ship and helicopter instrumentation package, data processing and presentation facilities. Furthermore, the introduction of pilot-in-the-loop simulation in the qualification process is discussed briefly.

## **2 Experience**

The Royal Netherlands Navy (RNLN), being one of the first operators of helicopters on small ships and operating world-wide, pioneered more than 40 years ago with National Aerospace Laboratory NLR in the development of helicopter-ship qualification procedures. This collaborative effort has led to a five-step qualification programme described in this report. NLR is the Netherlands expert institute on aerospace technology and related subjects. From 1964 to date it actively participated in twenty-one qualification programmes. Six of these programmes were carried out in co-operation with four international operators. In total thirteen classes of ships and eleven helicopter types were involved (Fig. 4).



Figure 4 Some helicopter types qualified in recent years by NLR for operations on board ships.

### 3 Qualification programme

#### 3.1 General

One of the most important requirements for helicopter compatible ships is the helicopter type to be operated from a given class of ship. This requirement implicitly defines the deck sizing, hangar spacing and technical support features for optimal and safe helicopter operations.

A ship can be considered as an isolated island, which is in turn domicile and working area of several disciplines. Each discipline has its own specific requirements.

The designers of a ship attempt to meet all requirements within predefined constraints. The final draft by the design office will therefore be a compromise, within which each discipline must strive to fulfil its tasks.

As the helicopter is one of the many systems of a ship, it is obvious that helicopter operations are to be performed within the constraints of the aforementioned compromise.

The main objectives of a qualification programme are:

- the determination of operational limitations, regarding flight as well as deck handling etc., for a specific helicopter-ship combination;



- the adjustment of standard operations;
- the establishment of additional rules and procedures if applicable;
- the establishment of a data base for safe future flight activities.

The determined SHOLs contain in general the following information:

- helicopter type / day or night / flight condition (launch/recovery or traversing/ranging the helicopter from hangar to flight deck and vice versa, etc.);
- applied flight procedures during launch/recovery;
- allowable maximum all-up masses of the helicopter;
- wind limitations. The data are presented as a polar diagram, the radius representing the wind speed and the azimuth the wind direction as measured by the ships' systems;
- allowable ship motions.

The execution of a complete qualification programme may seem to be rather elaborate. However the advantages that are gained in the long run are enormous. Once a ship and a helicopter have been qualified for ship-borne operations, updating the SHOLs after modifications on the helicopter or on the ship is relatively easy as only the relevant parts of the qualification programme have to be carried out. The same holds for the determination of SHOLs for a new helicopter type or a new class of ship put into service with the operator. In this respect the reader should be aware of the following:

1. The life cycle of a helicopter is nowadays 30 to 35 years.
2. The lead-time for the design and building of a ship is approximately 8 years.
3. The life cycle of a ship is at least 25 to 35 years.
4. Although the lifespan of both platforms is almost equal, they hardly ever coincide with each other.

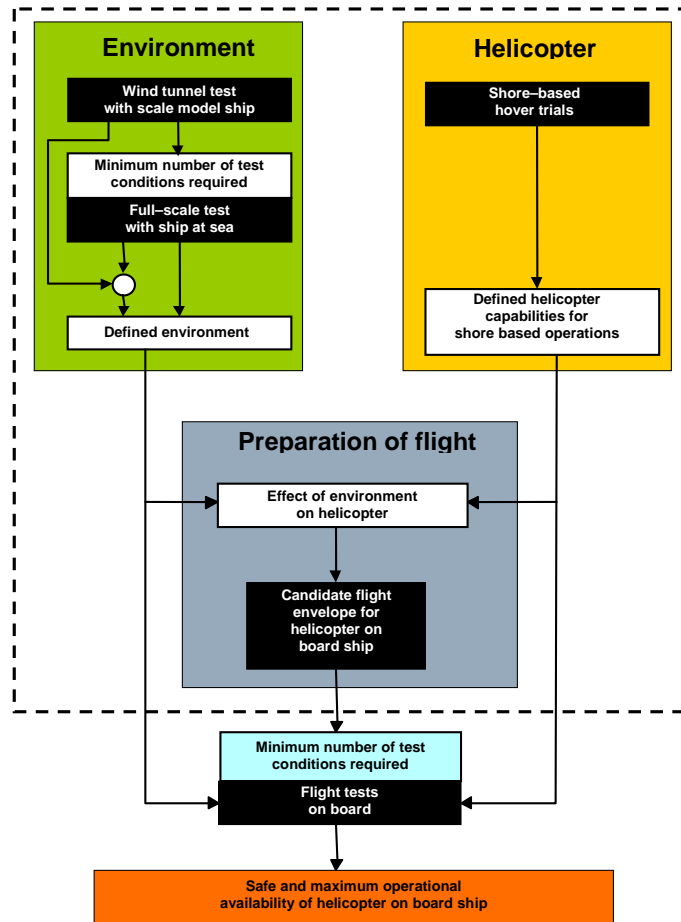

Figure 5 Set-up of helicopter-ship qualification programme as applied by NLR.

An important aspect of helicopter-ship qualification testing is safety. The problem is to define this in quantitative terms, taking into account the limitations imposed by the environment, the capabilities of the helicopter and the capabilities of the pilot. In order to obtain the required data in a safe and efficient way, a programme of preparatory measurements, analysis and flight testing is executed. The scheme presently in use is depicted in figure 5.

### 3.2 Environment

#### 3.2.1 Wind tunnel tests on a scale model of the ship

Wind tunnel tests on ship models are carried out to determine the airflow characteristics (airflow deviations with respect to the undisturbed oncoming relative wind, turbulence) above the flight deck and in the possible approach paths of the helicopter to the ship as function of the relative wind. The relative wind is the wind vector resulting from the true wind and ship's course and speed. Furthermore the ship's exhaust plume paths and prediction of plume temperature (by

plume dispersion measurement) as a function of ship's power settings and relative wind conditions are determined.

By carrying out these tests in the design stage of the ship it is often possible to determine that by a small change to the superstructure the airflow patterns above the flight deck can be improved and the exhaust gas nuisance can be decreased.

This prevents costly modifications of the existing ship. The same holds for the position of the ship's anemometers on a yard of a mast and in relation to other sensors. Furthermore one must keep in mind that an optimum stack/funnel design for flight operations does not automatically include an optimum for Infra Red Signature and/or Radar Reflection Cross-Section, so often compromises have to be made.

Finally the position error of the ship's anemometer is determined which is, apart from the instrumentation error of the anemometer, needed to establish the relation between the undisturbed relative wind conditions and those prevailing above the flight deck and along the helicopter approach paths.

An example of a wind tunnel investigation on stack and funnel design in relation to smoke nuisance, is presented in figure 6. The figure shows the original design (bottom part) and the proposed design (top part) determined from the wind tunnel investigation. Both situations presented are for identical head wind and exhaust gas dispersion.

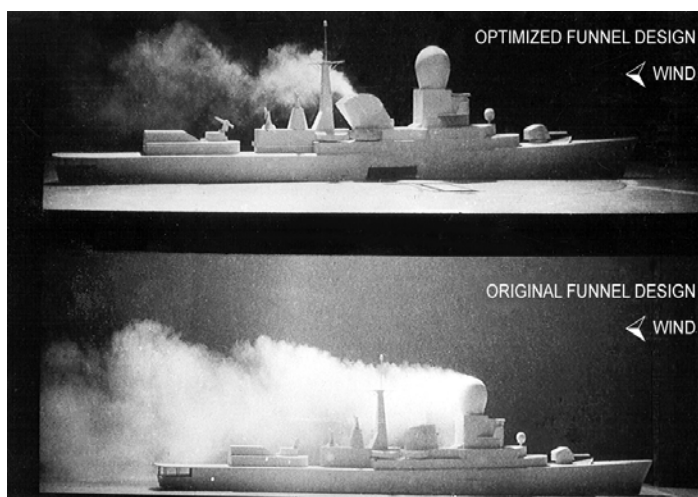

Figure 6 Stack & exhaust gas nuisance investigation on a wind tunnel model.

### 3.2.2 Full-scale ship's wind climate and motion tests

Airflow trials are conducted on every ship prior to helicopter tests on board. The aim of these tests is to establish the magnitude of errors in the ship's anemometer system. The instrumentation error of the ship's anemometer is determined and the position error, as established during the wind tunnel tests, is verified. With the information obtained, an



unambiguous relation between the anemometer readings, the air flow conditions above the flight deck and in the helicopter approach paths and the undisturbed relative wind condition is determined. Such information is vital since, unless the system is to a required accuracy, helicopter operations from that ship class will not be recommended.

Wind climate tests on board the ship are also carried out to verify the wind-tunnel test results concerning the air flow characteristics above the flight deck. For these tests two movable masts with wind measuring systems including temperature probes and data acquisition units are used by NLR.

One mast contains two measuring and acquisition systems at heights of 5 m and 10 m above the flight deck and the second a system at 3 m height (Fig. 7).

With the established relation between the wind tunnel test results and full-scale ship test results (Fig. 7), the actual wind climate in the various helicopter approach paths and over the flight deck can be predicted.

Furthermore ship motion characteristics (pitching and rolling motions) are determined as a function of sea state, wave/swell direction and ship's speed.

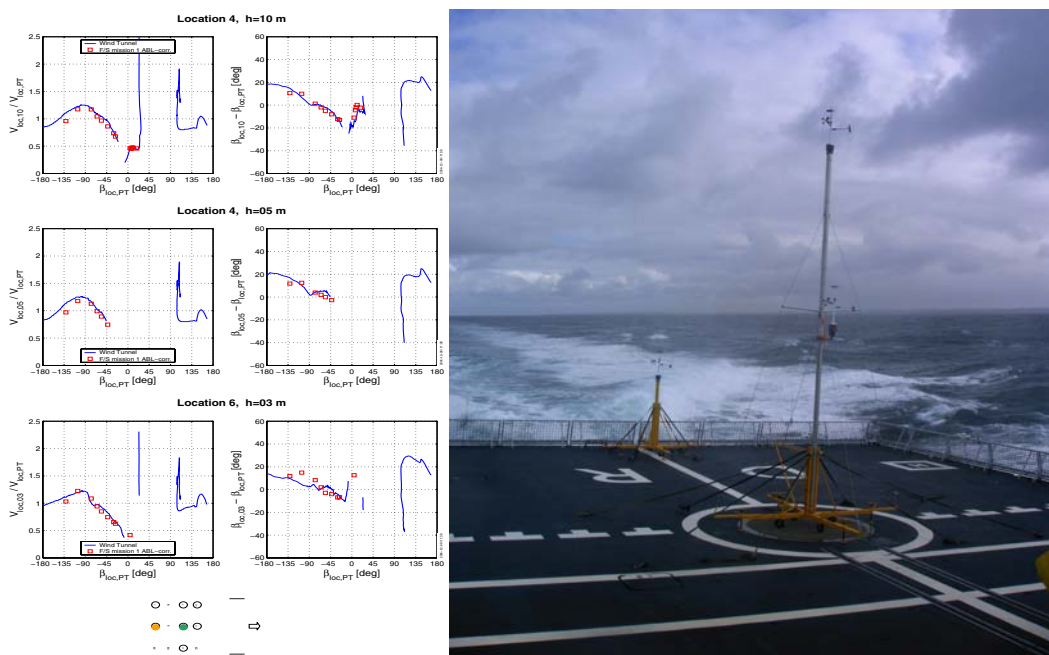

Figure 7 NLR moveable measuring masts on flight deck. The graphs on the left show the comparison of wind-tunnel- and full-scale measurement results.

### 3.2.3 Instrumentation

On board of the ship an instrumentation system is installed, consisting of:

- a reference anemometer system on the jack staff of the ship

- two masts containing three anemometer systems (Fig. 7)
- “Mobile” test centre (paragraph 3.5.6.1)
- a Data Acquisition Unit (DAU) (Fig. 8)

The recently renewed Data Acquisition Unit (DAU) (Fig. 8) can be easily reconfigured for various ships and is significantly reduced in size and weight, partly due to a touch-screen interface for the operator. The complete compact unit can be placed close to the ships’ wheel house.



*Figure 8 Data Acquisition Unit (DAU), installed in the vicinity of the wheel house.*

The DAU is developed to acquire ship parameters to obtain information of the environment during the ship-helicopter flight test trials. Specific parameters are ship roll and pitch movements, course and speed, wind information of the ship systems, position and temperature. Each ship class has a unique system configuration; to measure the various configurations the DAU is suited with a variety of interface boards.

### **3.3 Helicopter - shore based hover trials**

The purpose of the shore based hover trials (Fig. 9) is to establish power margins and controllability limits in omnidirectional wind envelope to complement the flight manual information, as these are generally lacking detailed information (Fig. 10).

The test is performed at several altitudes above ground level (AGL), yawing the helicopter relative to the ambient wind in steps of 45 degree increments and when necessary in smaller increments. Starting with head winds (wind on the nose of the helicopter) and working around from 0 to 405 degrees (360 + 45 degrees). When a stable hover condition is obtained, engine torque, rotor rpm, helicopter attitudes, and flight control positions are recorded in addition to ambient conditions (pressure altitude, OAT, ambient winds etc.).



*Figure 9 General set-up during shore based hover trials.*

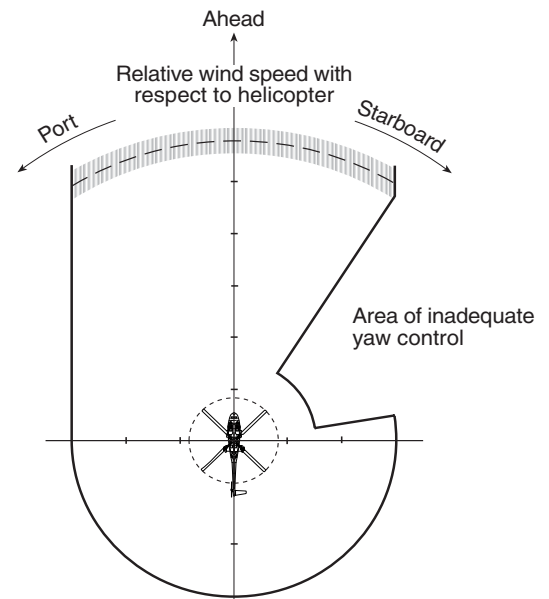

*Figure 10 Typical relative low wind speed envelope as provided by the manufacturer.*

Furthermore helicopter pitch and bank angles needed for hover at high wind speeds from all directions relative to the helicopter are determined. Finally tests are carried out in those wind conditions where main/tail rotor interference might exist, causing helicopter oscillations. It must be understood that these tests are executed within the limitations for land-based operations as given by the helicopter manufacturer.

The data obtained should indicate where, within the land-based envelope, regions exist where the margin between available and required helicopter performance is small. An example of torque and yaw control performance obtained from such tests is given in Figure 11.

The final results of this test programme provide a good baseline to work from to predict helicopter power and control performance requirements when operating in a disturbed airflow environment out at sea.

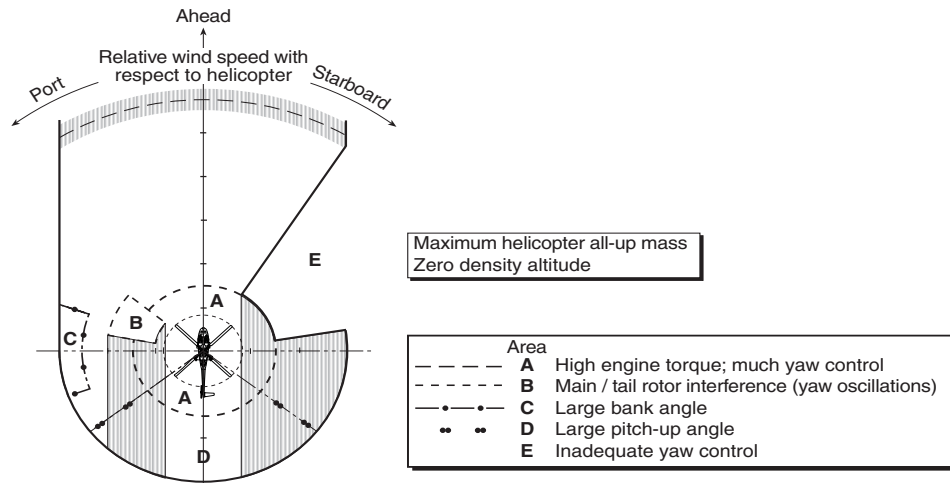

Figure 11 Detailed results from land based hover trials.

### 3.3.1 Instrumentation

In the past ten years the number of helicopter types operated by the Dutch Ministry of Defence has been doubled. Since modern helicopters are equipped with avionics systems with a digital databus, helicopter instrumentation systems should be capable to acquire the data directly from that databus. Based on the requirement for easy re-configurability for various helicopters (high flexibility) and with stringent requirements on the maximum size, the new NLR Generic Instrumentation System (GIS, Fig. 12) is designed to be compatible with most (modern) avionics systems.

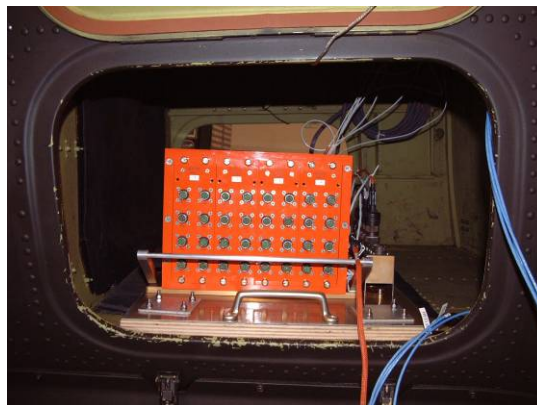

Figure 12 Generic Instrumentation System (GIS) installed in AH-64 helicopter.

The GIS contains data acquisition equipment (35 x 26 x 21 cm), additional sensors, a data registration recorder and a data processing station.

- **Data acquisition equipment**

The acquisition equipment is a KAM500 chassis with several interface boards. Based on a project parameter list, interface boards are selected to acquire the parameters. The

parameters are mostly available in aircraft systems as a: voltage, frequency, strain gauges or in MIL-STD-1553B and ARINC-429 data busses. For safety or budgetary reasons additional sensors can easily be installed (e.g. instead of using data from aircraft systems with unknown characteristics, requiring additional investigation).

▪ **Data recorder**

The data is recorded by a solid state recorder (SSR) with a capacity of 4GB, which is at least 8 hours recording time with a GIS data rate of 500 kbps.

▪ **Data Processing System**

The recorded data is extracted and directly archived at the Data Processing System (DPS). Hereafter the data is converted to the IRIG-Chapter 10 format. At this point the data can be replayed at the Omega Windows Ground System or it can be converted to Matlab™ binary files. In Matlab™ the quick-look analysis will be performed by NLR personnel.

**3.4 Candidate flight envelope**

The starting point is the land based relative wind diagram of the helicopter, based on the manufacturer’s low speed flight envelope and on the shore-based hover trials (fig. 11). When areas of the land-based relative-wind diagram, in which either of the hazardous conditions may occur are left out, a candidate ship-operation-relative-wind diagram results of which an example is shown in figure 13.

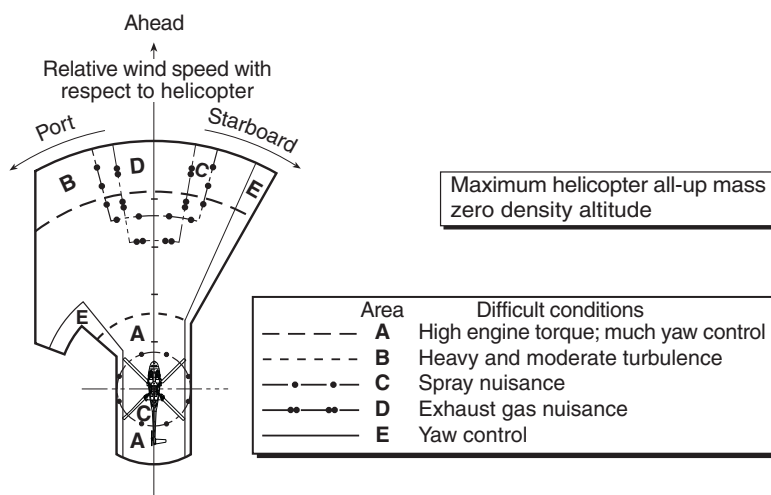

Figure 13 Candidate flight envelope to be tested on board a ship.

It should be noted that such a diagram results from measurement of the ship's environment, helicopter performance measurements and analyses. Whether or not the diagram can be used operationally has to be determined by means of dedicated flight tests. To determine those areas in which testing has to be carried out, an evaluation of conditions has to be made, where

difficult and demanding situations will occur for the pilot. Examples of these areas are shown in figure 13.

At low relative wind speeds, high power and large control inputs are required to precisely control the helicopter, while the ship's stabilization system being generally less effective causes additional control inputs (areas A, C & E) to correct for ship motions.

At high relative wind speed from ahead, the accompanying turbulence (moderate to heavy; area B) and especially the large pitch amplitudes of the ship need much control effort of the pilot which might result in such large power variations that the maximum allowable continuous torque is often exceeded. Besides, the presence of spray and exhaust gas (areas C, D), reducing the pilot's view over the flight deck, increases his workload even more. Hot exhaust gasses above the flight deck and along the helicopter flight path close to the ship, have a similar effect on the helicopter rotor and engine performances as increased density altitude.

The Candidate Flight Envelopes for ship-borne testing can be divided into various aircraft mass bands for each type of landing to be evaluated. Generally speaking, an aircraft will have a wider (larger) operating envelope at light all up mass (AUM) than at heavy AUM due to reduced control and power margins as the helicopter mass increases. The aircraft mass bands are decided upon before any trials take place and depend upon the particular aircraft. The aim is to produce several equally divided bands covering the range of masses at which the aircraft will be required to operate. This range normally extends some way beyond the maximum permitted AUM of the aircraft to account for non-standard atmospheric conditions. The test mass, calculated in terms of  $M/\sigma d$  (mass divided by density ratio) is referred to as density mass. The trials are conducted at various values of  $M/\sigma d$  which are used to produce the "density mass envelopes" which are issued by the operators.

The real challenge is to define the limitations imposed by the environment in quantitative terms.

From the analyses described previously, candidate relative wind diagrams can be constructed for various helicopter approach headings with respect to the ship (Fig. 14).

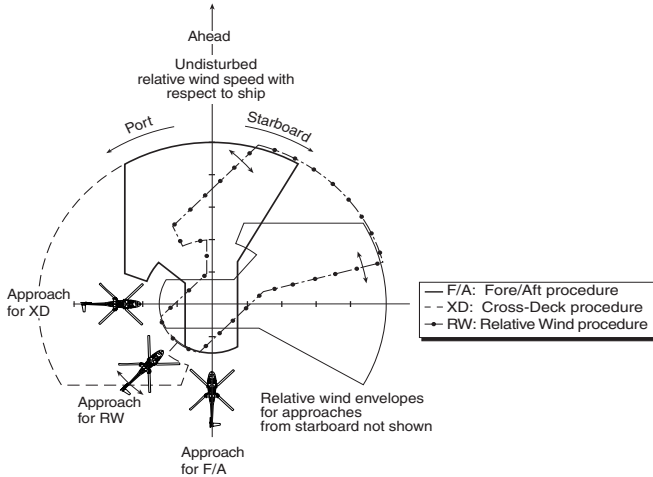

Figure 14 Composition of possible wind envelopes for various helicopter approach headings with respect to the ship.

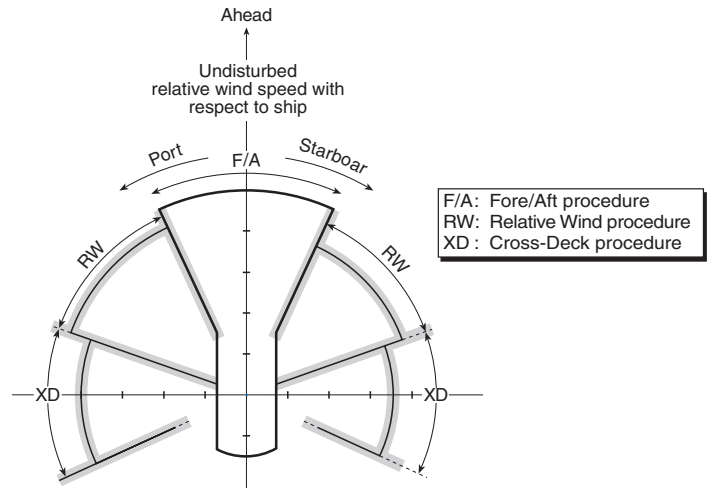

Figure 15 Example of a resultant Candidate Flight Envelope.

These diagrams then are combined to form a candidate helicopter-ship operations envelope. Since overlaps of the relative-wind diagrams for the various procedures will occur, a choice is made, taking into account the relative size of each of the overlapping sectors (maximizing the ship-borne operations envelope) and the expected ease of operating the helicopter. The trade-off is made, using operator requirements, engineering and pilot judgement. An example of a resultant Candidate Flight Envelope is shown in figure 15. Using ship anemometer calibration data, obtained during wind climate measurements, this operational envelope is related to wind information available on the ship in relation to actual wind conditions above the flight deck. An example of such an envelope (valid for the fore/aft procedure of Fig. 13) is shown in figure 16.

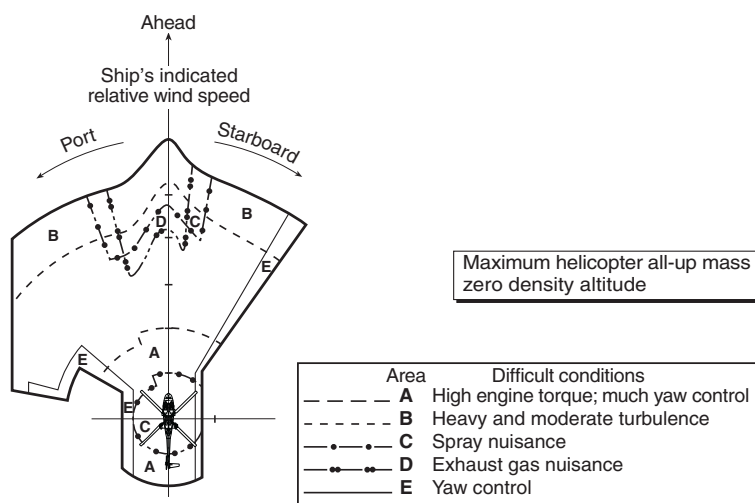

Figure 16 Candidate Flight Envelope, for fore/aft take-off and landing, corrected for ship anemometer system information.

### 3.5 Helicopter qualification flight testing on board a ship

#### 3.5.1 Test programme

The Candidate Flight Envelopes will contain a number of areas for which the analyses indicates a requirement for testing. The problems that may occur are identified and the test procedure and instrumentation, required to investigate these areas safely, are determined.

In these areas a number of conditions, which are preferably to be tested, are drawn-up.

Since the flight-testing is to be carried out on board a ship in a limited period of time, the exact conditions at which tests can take place cannot be determined beforehand. Conditions that will be tested depend on the sea-state and wind conditions that are present in the area where the tests are taking place. Of course, the area and time of the year are selected to maximize the probable occurrence of the desired test conditions. However, this still does not provide the experimenter with a free hand to vary his test conditions at will.

As evident from the previous paragraph, the flight-test programme has to be defined in an interactive way during the testing period. The actual execution of the flight-test programme is governed by three main aspects:

- safety,
- efficiency,
- available conditions.

Safety is principally obtained by starting the flight tests in conditions easy for aircraft and ship personnel, leading to test team familiarization:





- low helicopter mass
- relative-wind conditions well inside the boundaries of the candidate relative-wind envelope (no "tough" conditions; e.g. Fig. 2)
- fore/aft procedure (the easiest)
- fair weather
- first by day, later on by night.

After a thorough familiarization, efficiency is obtained by making adequate use of the information that becomes available during the flight tests and by analyzing, on board the ship, that information in conjunction with the data base obtained prior to the flight tests. Thus maximum use is made of the information obtained from the tests, and the number of test flights required can be minimized.

During the test period the selection of test conditions is a major task. Based on the analyzed results of the tests that have already been carried out, a number of alternatives for the next test condition are defined. This exercise is carried out in parallel for test conditions related to each of the potential problem areas of the Candidate Flight Envelope, thus yielding a large selection of usable test conditions. The choice of the next test condition then depends on the available forecast wind/sea state conditions in the area within reach of the ship. Problems like judging the reliability of weather forecast versus time of the ship to travel to the area of interest are to be solved.

Given certain environmental conditions (wind, sea state, temperature) a number of conditions can be created by changing ship speed and heading relative to the wind (relative wind conditions) and waves (flight deck motion), although these cannot always be changed independently. The only parameter that can be changed independently appears to be helicopter mass.

Clever use of information obtained on board, in conjunction with thorough knowledge of the factors that limit operations, is used to minimize the problems created by the difficulty to establish the most desirable test conditions. Often it is not a matter of demonstrating the capability to operate the helicopter at the condition specified, but to obtain data at differing conditions and interpolating or extrapolating the results to the conditions required.

For this purpose, the results can be graphically displayed. A MATLAB™ Graphical User Interface (GUI) has been developed to display the flight test results graphically. It provides the following functions (Fig. 17):

- Selection of the landing procedure and weight class (if applicable);
- Display of Candidate Flight Envelope;

- Display of previous runs of the same landing procedure, color coded (accepted/marginal/rejected);
- Cross plotting of previous runs: for example a run of one procedure and weight class at night which is accepted, will also be accepted in the same procedure and weight class during daytime. Cross plotted points are indicated with different symbols.
- Representation of encountered ship motion;
- Representation of wind envelope: the current or recently measured true wind can be used to calculate possible indicated (relative wind) conditions. In figure 24 this is represented by 2 blue round objects. The blue lines are not perfect circles, because the possible true wind conditions are converted to indicated wind.
- Representation and editing of test program. The yellow/red diamonds in figure 17 represent points of the currently selected test program. Test programs can be edited, loaded and saved. A set of briefing sheets can be printed containing a map of the current location, the applicable SHOL's with previous runs and test program, such as in figure 17.

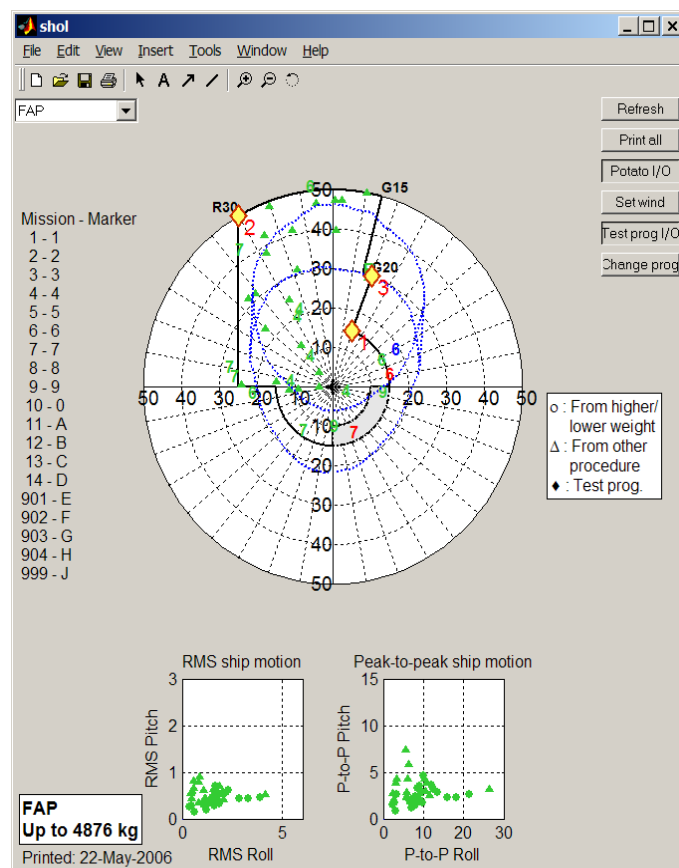

Figure 17 MATLAB™ Graphical User Interface in use with helicopter flight trials on board a ship.

Furthermore, for a series of test points, a range of required true wind speeds can be calculated and plotted. This is represented in figure 18. This tool helps the longer term planning of the test campaign, since it indicates if high or low true wind speeds are required. It also shows, for example, that the first and second condition in figure 18 can never be tested at the same time as the last two conditions.

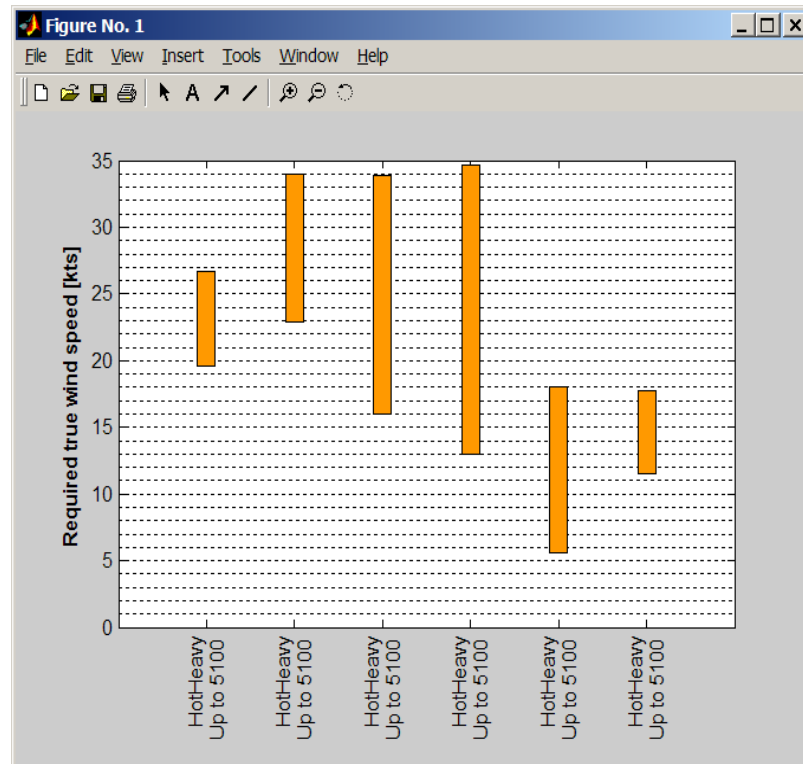

Figure 18 Graphic display to present true wind speed required for helicopter-ship flight trials.

Additionally, some other tools were developed:

- Easy plotting of time traces of selected parameters, including additional statistical functionalities.
- A ‘Course/Speed Advisor’ tool, which calculates on line what the ship’s course and speed should be using the current true wind and required test condition (indicated wind). Since this tool uses the ship’s sensor calibrations and wind tunnel results, it provides a faster and more accurate result than the manually calculated course and speed by the Officer of the Watch on the bridge.
- Data mining tool to obtain results over a large amount of runs (for example: maximum engine torque for all runs with high mass and green winds).

These tools were extensively tested, polished and compared to the older post-processing procedure during three test campaigns executed in 2005. The improvements in calculation speed

and graphical interface have reduced the entire post-processing procedure to a matter of minutes per run, allowing a fast analysis of the flight test results.

### 3.5.2 Test execution

To improve visualization of the available data, new Quick Look displays were developed, using the open structure of the Omega system (paragraph 3.5.6.3) custom Active-X. An example of the display used for the helicopter-ship flight trials is shown in figure 19.

In the top left corner the most critical helicopter data (radio altitude, pedal deflection, engine torque and lateral cyclic stick deflection) are displayed in strip charts, together with colour-coded limit indications. This enables the NLR crew to monitor the limiting parameters for flight safety.

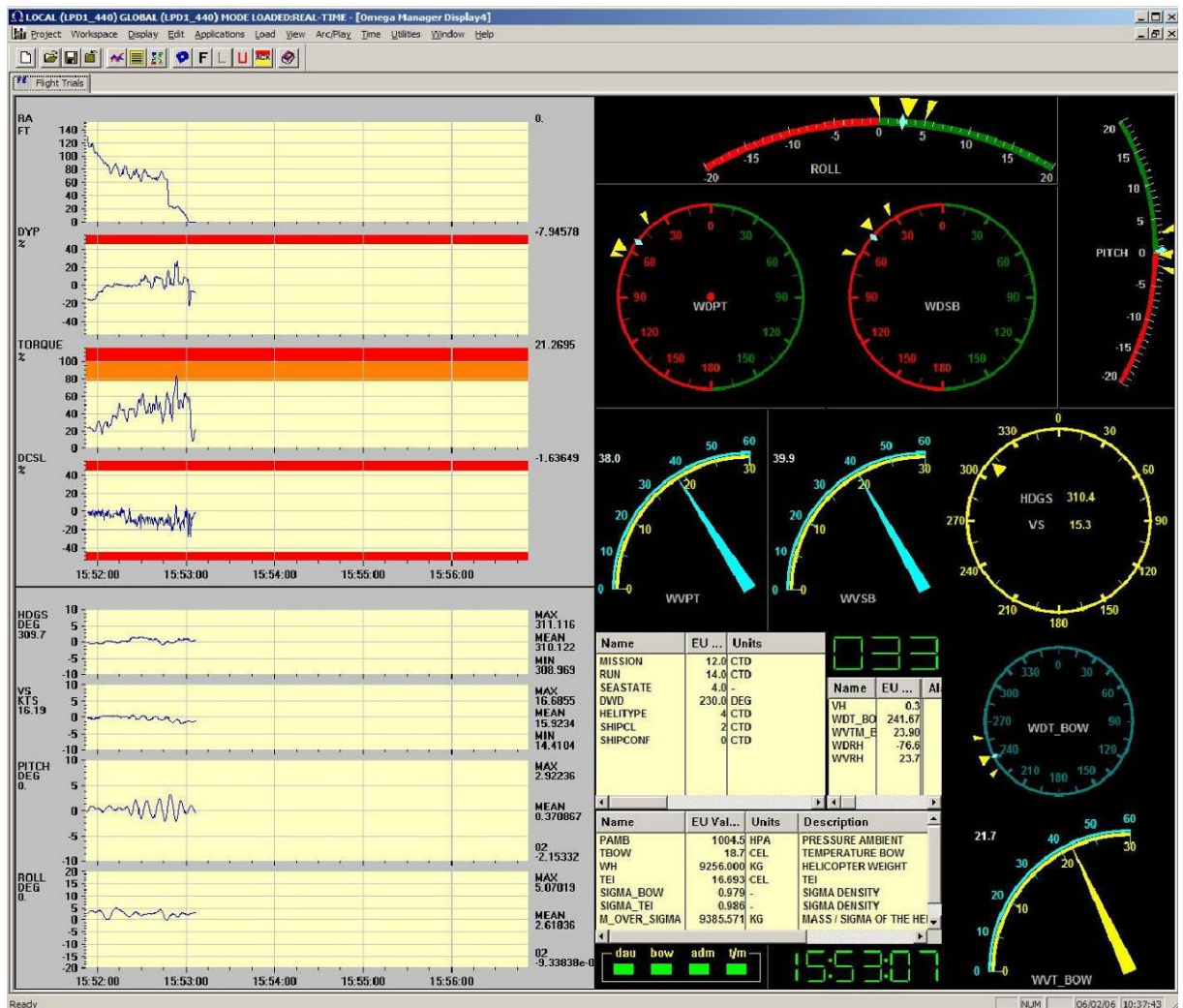

Figure 19 Real-time Quick-Look display for flight trials.



In the lower left corner the ship's heading, speed and motion in roll and pitch is displayed to monitor the stability of the conditions. These data are also presented in strip charts, however the offset of the x-axis is determined using the data in the first measurement which allows better monitoring.

The upper right part of the screen is used for angular gauge presentation of ship data, including wind direction and speed from the port and starboard ship anemometers. The wind direction gauges also display the minimum, maximum and mean value calculated during the measurement run.

In the lower middle part some administrative and more or less static parameters are displayed in table format. At the bottom some indicators are placed to monitor the instrumentation subsystems. Adjoining them is the colour-coded time-display, indicating the backup tape recording status in the helicopter (amber recording not started, green recording started). Finally in the lower right corner the true wind conditions are displayed. These are real-time calculated using the output of the reference anemometer on the bow and are corrected for instrument error and position error caused by ship geometry influence.

### **3.5.3 Post processing**

To attempt to assess all wind conditions at all masses would be a very large if not untenable task. The philosophy therefore allows for this by permitting landings at different masses to be read across (cross plotted) to other procedures. However, there are rules for this and not all take-offs or landings can be read across.

In essence take-offs or landings which are rated as unacceptable at low mass are also read up to higher masses as unacceptable. Take-offs or landings which are rated as acceptable at high mass are read down to lower masses. The reasoning behind this is perhaps obvious; an easy landing at high mass is also likely to be easy (if not easier) at a lower mass. Equally a landing which is rated as unacceptable at low mass because of lack of power or control margins will not be any better at a higher mass and the same is considered to be true of handling issues. This provides a rational basis for expanding the evidence available at any one mass without conducting a particular test point at that mass.

Recently, it has been decided to improve the post-processing activities that are performed after each run. The existing software written in Turbo Pascal was converted to a number of MATLAB™ scripts, which enabled the addition of a Graphical User Interface (GUI) and a number of additional functionalities.

After a run is finished, the data becomes available on the local network from Omega as a binary Matlab file. This file is post-processed as follows:

- Any required operations are performed to obtain a clean data set (such as removal of stale and overflow data).
- Subsequently spikes are removed from the data. Initially this is performed automatically. If required, this can be followed by a manual spike removal process, using a GUI, which allows fast and accurate spike removal (including undo function, usage of the mouse to remove multiple points).
- Post-processing: the measured (indicated) wind data is converted to undisturbed relative wind and finally to true wind using sensor calibrations and wind tunnel results.
- For analysis purposes the mean, minimum, maximum and Root Mean Square (RMS) of selected parameters is calculated and sent to file and hardcopy output.
- Selected mean and RMS data is added to an Excel sheet of the current test mission for manual addition of pilot rating and comments.

Subsequently, the results can be graphically displayed in the MATLAB™ GUI described in the paragraph “Test Programme”.

#### **3.5.4 Usage of test results**

Within the constraints imposed by the environment in which the tests have to be carried out, all effort is made to carry out the testing as efficient as possible. To this end the nominal procedure as depicted in figure 20 is used.

For each condition tested, the results are evaluated and subsequently the required increase in severity of the conditions of the next test condition is determined. Of course in this process both engineering insight and flight technical skill (of the pilot) is involved.

With the knowledge available in advance and the data obtained during the previous test flight, the influence of a given test condition on the helicopter limitations can be predicted rather well.

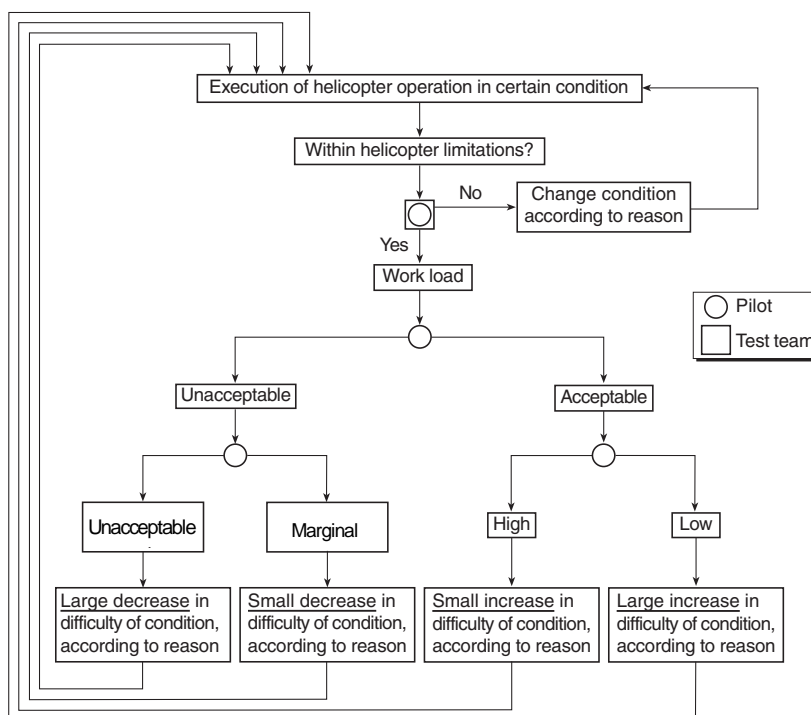

Figure 20 Flight test procedure on board the ship.

A prediction of the increase in pilot workload is only possible to a certain extent. If, for example, the workload in a certain condition is "low", the permitted increase in difficulty of the next test condition will be greater than in the case for "high" workload. The same rule is applied (in reverse). In case a condition is considered "marginal" a decrease in difficulty is applied whereas if the condition is considered "unacceptable", a larger decrease in difficulty is applied. With the application of these prediction methods, good engineering judgment and the experience of pilot and test team, the number of flying hours can be reduced to a minimum, and a maximum of results will be obtained in the shortest possible time.

### 3.5.5 Measured parameters

The essential helicopter parameters for the proper determination of the SHOLs are the same as measured during the shore based hover trials:

- engine torques
- control deflections
- pitch and bank angles
- heading
- radar altimeter
- Doppler velocities

- engine inlet temperature
- type-dependent additional parameters

The essential ship parameters are the same as measured during the wind climate and ship motion full scale tests, with the exception of flight deck wind and temperature parameters.

- speed
- heading
- wave/swell direction (estimation)
- pitching and rolling angles
- anemometer readings (relative wind condition)
- stabilization data
- propulsion mode

Pilot's comment on workload with respect to take-off and landing procedure, influenced by:

- ship's motions
- turbulence
- view over the flight deck
- spray and exhaust gas nuisance.

### **3.5.6 Instrumentation**

An overview of the complete instrumentation is given in figure 21. The system is modular in architecture allowing the same system to be used for the different measurement programs defined previously.



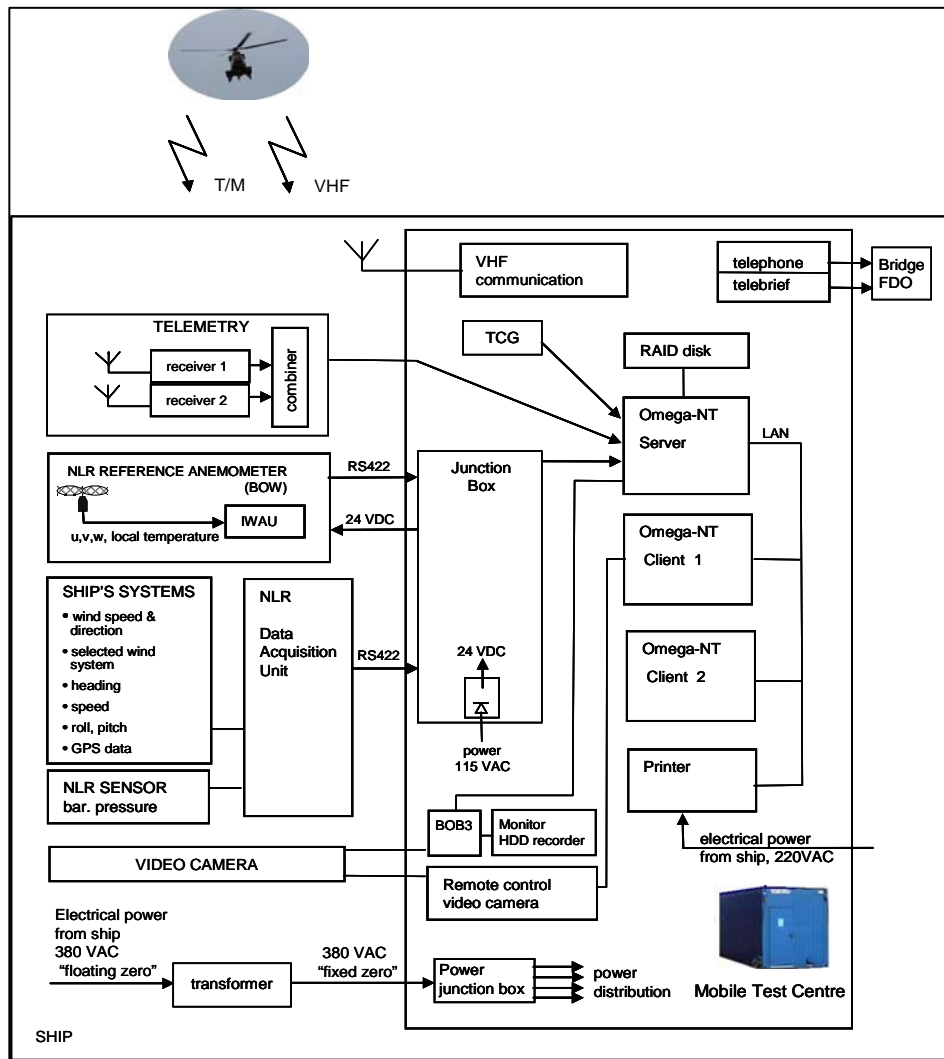

Figure 21 Block diagram of the instrumentation system used on board the ship.

### 3.5.6.1 Mobile test centre

Most of the equipment is installed in the mobile test centre which is used when sufficient space is available on board a ship (Fig. 22 and Fig 23).



Figure 22 Mobile test centre (porta-cabin) located in the hangar of “Hr. Ms. Rotterdam”.



Figure 23 Set-up of working stations in the mobile test centre.



Figure 24 NLR test centre in crew chief office.

Generally most ships are not so spacious as a support ship or a LPD (e.g. “Hr. Ms. Rotterdam”) and one has to make use of the available space in the vicinity of the hangar to create a test centre. In mutual concert with the maintenance crew chief use of his office can be made for the duration of the flight trials. An example of such a solution is shown in figure 24.

### 3.5.6.2 Telemetry receiving system

For reception of the helicopter data a mobile telemetry receiving system is used, consisting of two antenna/receiver combinations (Fig. 25). The antennas are spatially separated for improved telemetry coverage. The outputs of the receivers are combined in space diversity mode in a signal combiner for optimal signal output for the processing system. In order to reduce antenna cable length the unit is installed on board the ship in the close vicinity of the antennas.

The locations of the T/M antennas and the VHF antenna are shown in figure 26. Both T/M antennas are fitted with a plastic cover to protect them from salt water. All antennas are

mounted near the hangar and in such a manner that maximum line of sight with the helicopter is achieved.



*Figure 25 Telemetry receivers and signal combiner installed used by the test centre.*

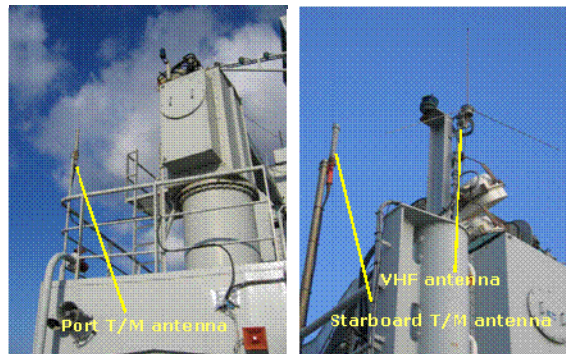

*Figure 26 NLR telemetry - and VHF antenna as installed on a ship.*

### 3.5.6.3 Telemetry ground station

The NLR telemetry ground station has recently been improved and now uses a WYLE Omega real-time telemetry processing system in a server-client network environment. The server is operated by the instrumentation engineer and processes and distributes all available data from helicopter, ship and anemometers. The system design allows for quick configuration changes for the different test programmes (i.e. activating or deactivating telemetry).

A shared RAID disk is used for securely archiving the received data.

The specialists are provided with client computers, enabling them to monitor and analyse the distributed data as necessary.

The network is completed with several laptop stations to facilitate in transport of data for further analysis off-line and a network printer.

### 3.5.6.4 Video camera

To monitor the helicopter movements in the vicinity of the flight deck, a remote controlled video camera is installed. Figure 27 shows the installation on a ship with a FLYCO cabinet. Generally the camera has to be mounted on an external position outside of the hangar. In this event a perspex dome (Fig. 28) is used to house and to protect the camera.

The camera is manually operated by the flight test team. For identification of the images a "BOB3" unit (a Dutch acronym for picture-in-picture) is used for inserting mission and run numbers obtained from the Omega server into the video picture.

The video data is recorded on a HDD/DVD video recorder.



*Figure 27 Video camera installed in the FLYCO cabinet.*

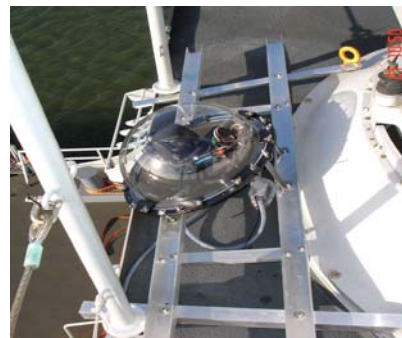

*Figure 28 External installation of the video camera.*

### **3.6 Drafting SHOLs/Constructing Wind Envelopes**

The operational wind envelopes are drawn up around the acceptable test points attained during the trials. The complete SHOL comprises both the wind envelopes and the ship motion limitations.

Different envelopes are produced for use by day and by night. The main difficulty with landing at night is due to the scotopic vision of the human eye in these conditions. At low light levels the visual acuity of the eye is degraded so that distance and hence speed/closure rate are difficult to judge. For this reason winds from astern are not cleared for night operations anymore. The RNLN experience has shown that there are too many pilots' errors of judgement leading to overtorqueing and/or overshooting the approach. In general this is the only difference between day and night wind envelopes. The deck motion limits applied at night are generally somewhat lower than those permitted by day.

At the completion of the flight tests on board the ship, a fair idea about the operational limitations has usually been obtained. For final results, measured data (of helicopter and ship) together with pilot's comment are analysed in detail. The operational limitations are presented in the form of graphs. An example is given in figure 29. In this graph limitations are given for the fore/aft take-off and landing for two density masses.

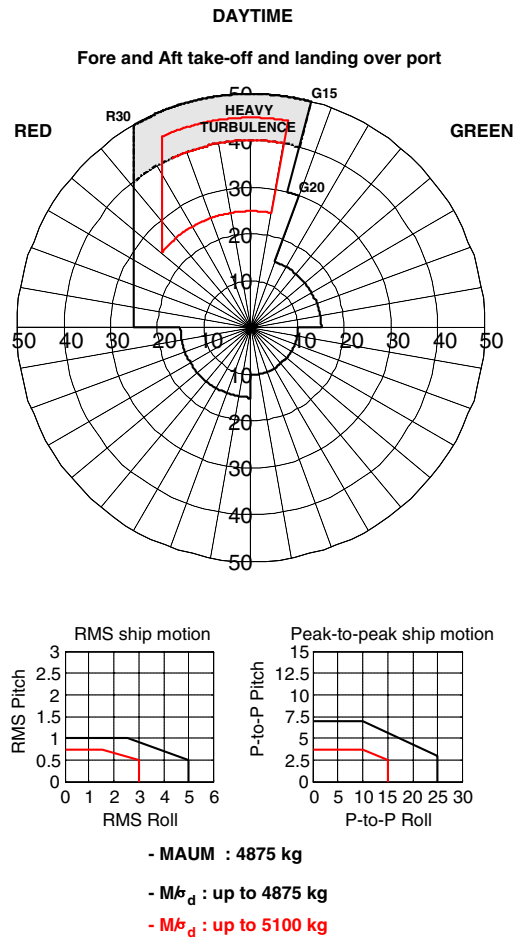

Figure 29 Example of SHOL for daytime fore-aft procedure.

Following the determination of acceptable wind envelopes and ship motion limits, the SHOLs for a range of aircraft density masses are issued to the operators. Furthermore, flight safety advice concerning modifications to the ship such as improved deck markings or lighting and any warnings about turbulence are also given. Should any helicopter deficiencies have come to light during the trials then these will also be brought to the attention of the appropriate authority.

#### 4 Introduction of simulation in qualification programme

In the last 2 years research has been performed at NLR in the ROSDIS project (Ref. 3) to develop a simulation capacity aimed at supporting the current SHOL determination process in the future. A helicopter ship simulation capacity enables safe exploration of the Candidate Flight Envelope in an early stage without depending on the availability of personnel and materiel. Also, in simulation, the required environmental conditions (strong winds, low density) can be set, including heavy ship motion which sometimes does not occur during flight testing. It

is therefore expected that in the future simulation can reduce the required (flight & sailing) testing effort and will further increase safety during the flight trials.

Modelling of the rotorcraft-ship dynamic interface consisted of three main items: ship wake, ship motion and helicopter modelling. The ship air wake has been implemented using steady wind tunnel rake wake measurements, available from the current SHOL determination method. Both NLR measurements of full-scale ship motions and off-line 6 degrees of freedom ship motion calculations have been used for implementation in the simulation. The latter approach enables the use of simulation at a stage when the ship has not yet made its maiden trip. Also, calculated ship motion provides the opportunity to explore the operational limits beyond the measured ship motions. A flight mechanics model of the Westland Lynx has been developed to enable comparison between simulation results and flight test. The most recently qualified RNLN ship and flight test data was used to validate the helicopter model.

For the pilot-in-the-loop simulation sessions NLR's Helicopter Pilot Station (HPS) was used (Fig. 30). The HPS is a fixed-base, reconfigurable research simulator. It consists of a fixed cockpit surrounded by three screens, providing a field-of-view of 135° by 34°. A digital electric control loading system provides force feedback on the collective, stick and pedals.

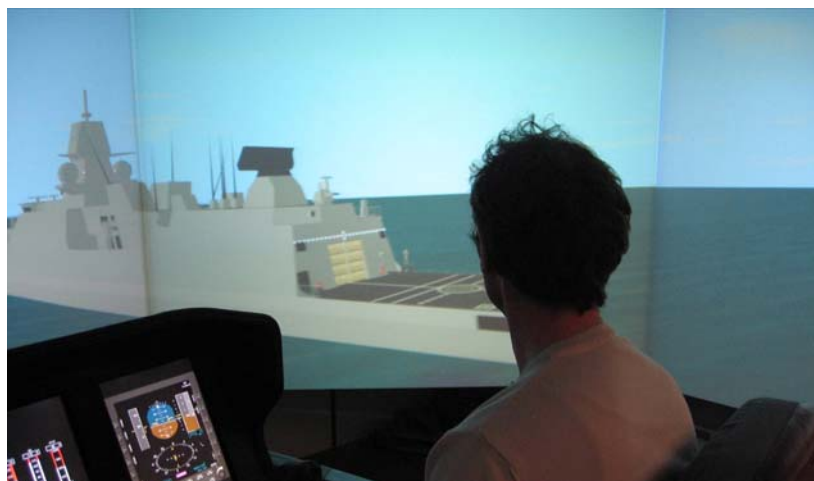

*Figure 30 Helicopter Pilot Station.*

For the purpose of ROSDIS, generic instrument displays are used created with the NLR tool VINCENT [ref. 4]. The outside visual model of the RNLN ship was enhanced with a glide path indicator, horizon bar and animated Flight Deck Officer. At the end of 2007 the visual system of the HPS will be upgraded to a field of view of 180° by 50°.

Through piloted sessions in the HPS, the fidelity of the modelling was regularly evaluated and further improvements were defined. In the final phase of the project the same environmental conditions as in the most recent helicopter-ship flight trials will be reproduced and several

RNLN pilots will participate. This allows for a unique comparison with flight test data from the NLR sea trials.

The fidelity of the simulation capacity will likely be further evaluated in a follow-up project. The focus will be on the actual use of simulation by running parallel to the upcoming qualification process of the next RNLN helicopter-ship combination.

## **5 Concluding Remarks**

A description of the five step approach for the helicopter-ship qualification as applied by NLR in the Netherlands is given together with an outline of the aspects to be tested and the influences of various factors on each aspect. The programme build up is such that the risk and the time required for the actual helicopter flight testing on board a ship is minimized.

This methodology has been applied and further refined since 1964. The Dutch clearance process has been successfully and safely applied for over 4 decennia.

To be able to efficiently and safely perform the large amount of upcoming qualification programmes, NLR has upgraded their ship and helicopter instrumentation package, as well as data processing and presentation facilities in the past few years. These new facilities were proven to be valuable in several test campaigns in 2005 and will continue to be enhanced in the future.

Furthermore, pilot-in-the-loop simulation is introduced parallel to the qualification process to develop a simulation capacity aimed at supporting the current SHOL determination process in the future. It is expected that pilot-in-the-loop simulation will be a valuable contribution in both the determination of the Candidate Flight Envelope as well as the evaluation of the flight test results.

So, the Dutch helicopter-ship qualification process is clearly ready for the future.

## 6 References

- [1] R. Fang, P.J.A. Booij, “Helicopter-Ship qualification testing, The Dutch clearance process”, Presented at the American Helicopter Society 62<sup>nd</sup> Annual Forum, Phoenix, Arizona, May 9-11 2006
  
- [2] P.J.A. Booij, A.J. Striegel, and J. van der Vorst, “Recent developments for efficient helicopter-ship qualification testing”, Presented at the 17th SFTE (EC) Symposium, 12-14 June 2006, Amsterdam, the Netherlands
  
- [3] G.C.S. Hommel and J. van der Vorst, “ROtorcraft Ship Dynamic Interface Simulation (ROSDIS)”, Presented at the 32<sup>nd</sup> European Rotorcraft Forum, 12-14 September 2006, Maastricht, the Netherlands
  
- [4] R.P.M. Verhoeven and A.J.C. de Reus, “Prototyping interactive cockpit applications”, Conference paper DASC 2004