

UNCLASSIFIED

Nationaal Lucht- en Ruimtevaartlaboratorium

National Aerospace Laboratory NLR

Executive summary



Folding, Adaptive, Steerable Textile Wing Structure for Capital Loads

Description of the Guidance, Navigation and Control System

Problem area

The FASTWing CL, the “Foldable Adaptive Steerable Textile Wing for Delivery of Capital Loads” – project is aiming at the development of a GPS navigated parafoil/payload system for cargo up to 6000kg. The main applications focus on airdrop systems for “humanitarian aid” and “military delivery”, as well as rescue and recovery systems for aircraft and space vehicles.

The steering of the parafoil is performed under control of a Guidance, Navigation and Control system. The aim of this system is to guide the parafoil autonomously towards a pre-programmed target point within a distance of 100 m. The FASTWing CL project is supported by the European Commission.

Description of work

This activity includes the realisation of a guidance system that controls the deflection of the trailing edge of the parafoil. This onboard computer system, called the Guidance, Navigation and Control System, computes the deflection using position information from various sensors and commands two

actuators accordingly. The computer system uses a tailored version of the control software that is used for the SPADES system (an NLR/Dutch Space development). The two actuators are controlling the steering lines connected to the trailing edge of the parafoil system. This actuator system is using commercially available actuator and control systems.

Using standard batteries to power the actuator system would result in a large and heavy power pack. Therefore an advanced power supply has been developed that makes use of ultra capacitors. Using this technology the weight and size of the power pack has been tremendously reduced.

Results and conclusions

Extensive ground tests have been performed and these tests have shown that the system meets the requirements. Flight tests are scheduled with loads up to 3200 kg (restricted by carrier aircraft).

Report no.

NLR-TP-2009-094

Author(s)

P.M.N. Hollestelle
A. Grunwald
A. Jimenez Olazabal

Report classification

UNCLASSIFIED

Date

December 2009

Knowledge area(s)

Avionicasystemen

Descriptor(s)

Guided parafoil
Guidance, Navigation and Control

This report is based on a presentation held at the 20th AIAA Aerodynamic Decelerator Systems Technology Conference and Seminar, Seattle (U.S.A.), May 2009.

UNCLASSIFIED

Folding, Adaptive, Steerable Textile Wing Structure for Capital Loads
Description of the Guidance, Navigation and Control System

Nationaal Lucht- en Ruimtevaartlaboratorium, National Aerospace Laboratory NLR

Anthony Fokkerweg 2, 1059 CM Amsterdam,
P.O. Box 90502, 1006 BM Amsterdam, The Netherlands
Telephone +31 20 511 31 13, Fax +31 20 511 32 10, Web site: www.nlr.nl



NLR-TP-2009-094

Folding, Adaptive, Steerable Textile Wing Structure for Capital Loads

Description of the Guidance, Navigation and Control System

P.M.N. Hollestelle, A. Grunwald¹ and A. Jimenez Olazabal²

1 Technion, Israel



2 CESA, Spain

This report is based on a presentation held at the 20th AIAA Aerodynamic Decelerator Systems Technology Conference and Seminar, Seattle (U.S.A.), May 2009.

The contents of this report may be cited on condition that full credit is given to NLR and the authors.

Customer	European Commission
Contract number	----
Owner	National Aerospace Laboratory NLR
Division NLR	Aerospace Systems & Applications
Distribution	Unlimited
Classification of title	Unclassified
	December 2009

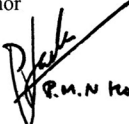
Approved by:

Author  P.M.N. Hollestelle	Reviewer 	Managing department 
---	--	--

Summary

The FASTWing CL, the “Foldable Adaptive Steerable Textile Wing for Delivery of Capital Loads” – project is aiming at the development of a GPS navigated parafoil/payload system for cargo up to 6000kg. The main applications focus on airdrop systems for “humanitarian aid” and “military delivery”, as well as rescue and recovery systems for aircraft and space vehicles.

Under this project a Guidance, Navigation and Control System (GNCS) was developed. This activity includes the development of an advanced power supply, based upon the use of ultra capacitors. The system will autonomously guide the parafoil towards a pre-programmed target point within a distance of 100 m. This will be done by controlling the deflection of the trailing edge of the parafoil. An onboard computer system will compute the deflection using position information from various sensors and commands the two winches accordingly.

The FASTWing CL project is supported by the European Commission under EC contract AST-CT-2006-030778.



This page is intentionally left blank.

Contents

1	Introduction	7
2	Summary description	7
3	Design Goals	8
4	Task division	9
5	Architecture of the Guidance, Navigation and Control System	9
5.1	Guidance, Navigation and Control Computer System	11
5.1.1	GNCIU Software	12
5.1.2	Sensors	13
5.1.2.1	GPS/Heading Sensor	14
5.1.2.2	Barometric pressure	14
5.1.2.3	Radar Altimeter	14
6	Actuator System	14
7	Power Supply	16
7.1	Energy and power demand considerations	17
8	TeleCommand/Telemetry System	19
9	Integration	20
10	System test	21
10.1	Closed loop laboratory test	21
10.2	Actuator/Power Supply Test	22
10.3	Flight tests	24
10.3.1	Open Loop Test	24
10.3.2	Closed loop test	24
11	Conclusions	25



Abbreviations

AC	Alternating Current
AR	Angle of Roll
CEP	circular error probability
DC	Direct Current
FASTWing CL	Folding, Adaptive, Steerable Textile Wing Structure for Capital Loads
FDAS	Flight Data Acquisition System
GBCS	Ground based Control System
GNCCS	Guidance, Navigation and Control Computer System
GNCIU	Guidance, Navigation and Control Interface Unit
GNCS	Guidance, Navigation and Control System
GPS	Global Position System
Hdg	Heading
PLC	Programmable Logic Controller
RA	Radar altitude
T/M	Telemetry



1 Introduction

The Foldable Adaptive Steerable Textile Wing for Delivery of Capital Loads (FASTWing CL) project is supported by the European Commission under the 6th framework program and is aiming at the development of a GPS navigated parafoil/payload system for cargo up to 6000kg. FASTWing CL is a successor of the former FASTWing project. The main applications focus on airdrop systems for “humanitarian aid” and “military delivery”, as well as rescue and recovery systems for aircraft and space vehicles.

The project objectives comprise the development of a high performance parafoil, reliable opening of the parachute system, development of an all-electrical steering box enabling high accuracy and soft landings and development and adaptation of advanced design and simulation tools.

Under this project a new Guidance, Navigation and Control System (GNCS) has been developed that will steer the vehicle autonomously towards a predefined landing point. The system will be demonstrated from release altitudes up to 25000 ft.

In the FASTWing CL GNCS two novelties have been introduced:

Use will be made of a combined GPS/Heading system to obtain the navigation parameters;
To provide the high power demand for the actuator system ultra capacitors have been used.

This publication describes the proposed system architecture for the Guidance, Navigation and Control System.

This FASTWing CL project is supported by the European Commission under EC contract AST-CT-2006-030778.

2 Summary description

This parafoil system can be autonomously steered towards a predefined target using a Guidance, Navigation and Control System (GNCS). This system retrieves the present position and heading information from a combined GPS/Heading system and calculates the steering vectors towards the pre-programmed target and operates the control lines accordingly by sending commands to an actuator system. Thereby the heading information will support the calculation in order to estimate the wind direction. Control of the actuator system will only start when the parafoil system has been fully deployed to avoid tangling of the control lines. A radar altimeter system,



measuring the shortest distance to the ground will be used to initiate the flare manoeuvre at the proper time in order to gain a smooth landing.

Essential information, such as position, control commands and other relevant data is telemetered to the ground for real-time monitoring using a bi-directional data link in order to react accordingly in case of malfunctions. Using a Ground Based Control Station (GBCS) the system can also be controlled remotely.

The large size of the parafoil will also require considerable forces to pull the control lines, especially during the flare manoeuvre. These large forces will be provided by a capable actuator system under control of the on board computer.

The actuator system will accept the commands from the GNCS computer system and will move the winches accordingly. The motors have been chosen such that these can move the winches under full load and with the speed that is required for a smooth landing.

A power supply will provide power to the control and actuators system during all phases of the flight. Thereby the most power demanding phase will be the flare phase. To reduce high electrical currents it has been decided to make use of a high voltage ultra capacitor to provide the power for the actuator system. The + 390 VDC power for the actuator system is retrieved from the ultra capacitor, while a DC-DC converter and a battery will charge the capacitor. It is expected and tested that during the normal descend phase the ultra capacitor will remain within 80-100 % of its capacity. During the flare manoeuvre the ultra capacitor is fully emptied.

The GBCS is equipped with an emergency switch. Upon activation a command is sent to the onboard GNCS that energizes a relay which in turn activates an Emergency System. Upon activation the Emergency System disconnects the Steering Box, containing all guidance and control equipment from the main pallet and initiates the opening of a smaller parachute system that is attached to the Steering Box. In this way the unique equipment will be saved.

3 Design Goals

The design goal for the GNCS system is that the system shall be capable to steer the full loaded parafoil system autonomously from an altitude of 25.000 ft towards a predefined target point and land smoothly within a circular error probability (CEP, 50 %) of 100 m from the target point. The wind profile should be calculated from the flown flight path and used in the steering process. It shall be possible to steer the system along a number of predefined waypoints.

4 Task division

The design and realisation of the GNCS has been performed in close cooperation with the following partners:

- CESA (Spain) was responsible for the design and realisation of the actuator system;
- Technion University of Haifa (Israel) has designed and manufactured the power supply box;
- The hardware to install the equipment (Steering Box) has been provided by Dutch Space (The Netherlands).
- NLR was responsible for the sensor and computer system for the GNCS and the final integration.
- NLR was also responsible for the Ground Based Control System, including the telemetry and telecommand system.

5 Architecture of the Guidance, Navigation and Control System

The Guidance, Navigation and Control System consist of the following main subsystems:

- Guidance, Navigation and Control Computer System;
- Actuator System;
- Power Supply;
- Telemetry and Telecommand System

Two secondary systems, the Emergency System and the Flight Data Acquisition System have been installed. The entire system will be installed in the so-called Steering Box.

A general block diagram of the GNCS is provided in Figure 1.

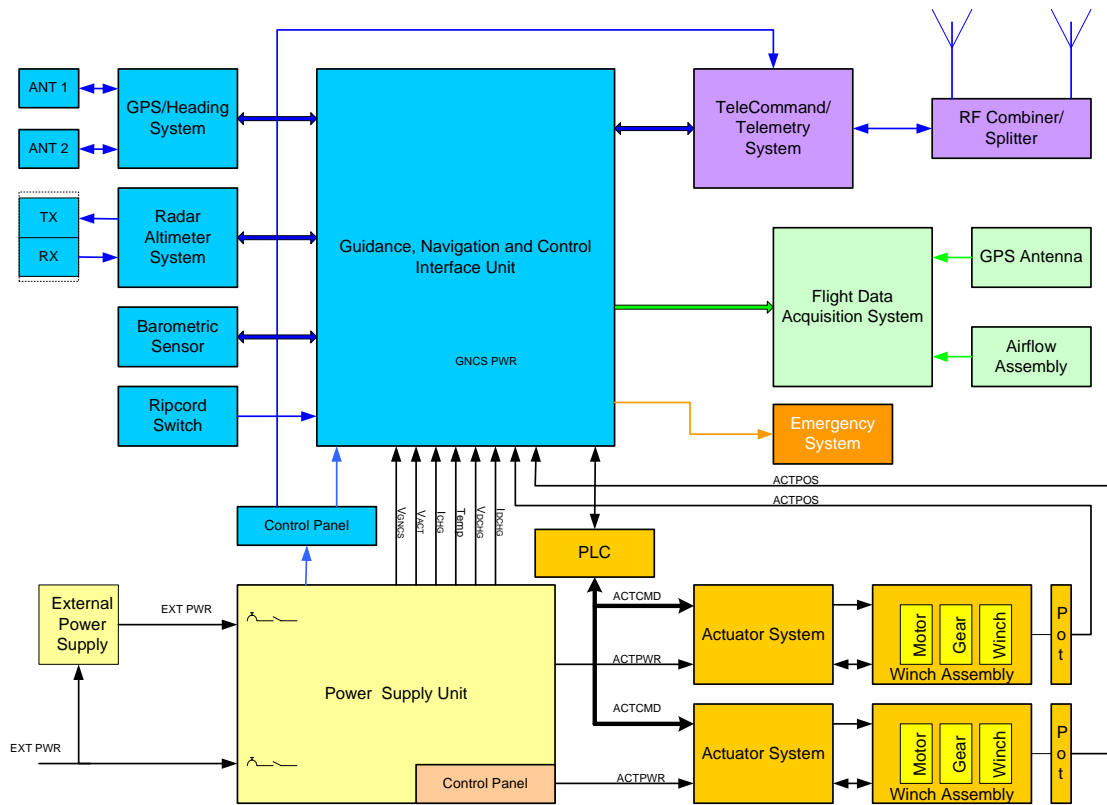

Figure 1 Block diagram of Guidance, Navigation and Control System

The heart of the Guidance, Navigation & Control System is the Guidance, Navigation & Control Computer System (GNCSS). This system consists of the Guidance, Navigation and Control Interface Unit (GNCIU) and a number of sensors that provides the navigation data. Based upon the information from the sensors the guidance software calculates the steering commands for the actuator and next it outputs the appropriate control commands to the Programmable Logic Controller in the Actuator System. The latter will steer the winches to the desired position.

The power supply for the system is provided by a 28 VDC battery. In order to reduce the current a supply voltage of 390 VDC has been chosen to power the actuator.

The 390 VDC supply voltage is provided by a DC/DC converter (28 VDC > 390 VDC) that charges an ultra capacitor and the latter will be used to supply the actuator power. During actuator movements the ultra capacitor is discharged and will be recharged when the system is not active. The power supply is described in more detail in Chapter 7.

Via a bi-directional Telemetry and TeleCommand System essential information is sent to a Ground Based Control Station (GBCS). In this way the behaviour of the system during descent can be monitored. If necessary the same link can be used to send remote control commands,

from the GBCS, to the GNCIU. With the GNCIU in Remote mode the parafoil system can be controlled manually.

The GBCS consists of the following components:

- Mission Planning and Support Station;
- Remote Control and Monitor Station;
- Ground-based part of the bi-directional data link system

More information on the GBCS is given in chapter 7: TeleCommand/Telemetry System

During power up the GNCIU loads a number of predefined mission planning parameters that has been stored on a memory stick during mission planning. To enable post flight analysis a number of relevant parameters will be stored during flight on the same memory stick.

The Emergency System will initialize and deploy an emergency parachute system in case of problems and aims for a safe return of the Steering box with the GNCS equipment.

A separate Flight Data Acquisition System (FDAS) will be resident on board the payload for acquisition and recording of a number of flight and control parameters. This data will be used for post flight analysis, e.g. system identification.

5.1 Guidance, Navigation and Control Computer System

The Guidance, Navigation and Control Computer System consist of the Guidance, Navigation and Control Interface Unit (GNCIU) with a number of sensors that provides navigation data. The GNCIU is built on COTS PC-104 compatible computer hardware and installed in a rugged housing (see Figure 2).

Based upon data, provided by the attached sensors, that provides information to the Guidance, Navigation and Control Interface Unit (GNCIU) e.g. position and heading data, will calculate the actuator commands to steer the payload to a predefined landing area. Immediate after booting the GNCIU will start processing the sensor data and calculate steering commands.



Figure 2 Mechanical Installation of GNCCS

However, since the parafoil is still stowed, actuator control is still inhibited. A ripcord switch that is connected to the confluence fitting will indicate that the parafoil extraction is under way

and after a determined delay the actuators will be enabled. At the landing area the flare manoeuvre will be automatically initiated at a predefined height above the ground. The latter information is provided by a Radar Altimeter (RA) that measures the shortest distance to the ground.

The GNCIU will issue the commands to the actuator system in a predefined format over a RS-232 serial link to a Programmable Logic Controller (PLC). The PLC will properly format the commands for communication with the actuator controllers over a CAN bus. In the same way the actuator controllers send status information to the PLC over the CAN Bus and the PLC sends these data over the serial link to the GNCIU.

TeleCommands that are received over the TeleCommand link are decoded by the software and will be used to control the actuators remotely. In order to execute Remote Control commands the GNCIU shall be put in the Remote Mode using a TeleCommand.

A number of analogue parameters (e.g. battery voltages, actuator position and currents) from the actuator and power system are also inputted by the GNCIU and will be used for flight monitoring and analysis afterwards.

The GNCIU is powered either from a + 28 VDC battery or from an external power supply (during ground test).

A notebook computer can be hooked up to the GNCU to see current status information.

5.1.1 GNCIU Software

The software in the GNCIU consists of two parts, i.e. the Basic SoftWare package (BSW) and the Application SoftWare Package (ASW). The BSW consists of the operating system, the drivers and the service routines to transfer data between the GNCS and the external interfaces and between the BSW and the ASW. The ASW software consists of the Guidance, Navigation and Control software, i.e. the software used to navigate the system towards the pre-programmed target point by controlling the steering lines of the parafoil. The navigation function is using current position and altitude and it will also take the wind parameters into account. These parameters are internally calculated.

The parameters in the control algorithms in the guidance software are strongly dependent on the dynamic behaviour of the parafoil. Since the parafoil as used in the FASTWing CL program is a new design, little information on the behaviour is available. Currently the algorithm will be

based upon information that is derived from mass, moment of inertia etc. During a number of flight test the proper parameters for the guidance algorithm will be optimized. This optimization is performed during a number of flight tests (see chapter 24). A number of dedicated parameters will be recorded during these tests. After the tests, the recorded data will be analysed in order to determine the dynamic characteristics of the system. It may be possible to override the autonomous control with the remote control unit and to perform dedicated manoeuvres.

Fast movements of the actuator motor, either commanded by the GNCIU in the autonomous mode or by means of the remote control system may cause overload of the actuator controller, resulting that the respective controller will not function any longer, until it has been reset. Since in flight reset is not possible, precautions, such as filtering of the control signals to avoid these fast movements, have been taken in the GNCS software.

Prior to the flight a number of mission planning parameters, like target point position and other setup parameters, such as filter coefficients and autopilot parameters will be loaded into the GNCIU. These parameters are prepared using a Mission Support System and stored on the USB memory stick. Next this memory stick can be inserted GNCCS rack from the outside. During Power-Up initialization these parameters are fetched by the GNCIU and used to calculate the flight path. Through the same mechanism it will be possible to enter parameters for the guidance and control algorithm.

Relevant data will be recorded during the flight on the same USB stick for processing afterwards. Stored parameters include:

- Current position
- Angle of Roll
- Course
- System mode
- Heading
- Speed
- Battery Voltages and currents

5.1.2 Sensors

Navigation data for the guidance process is provided by the following sensors:

- GPS/Heading Sensor
- Barometric Sensor
- Radar Altimeter

5.1.2.1 GPS/Heading Sensor

The GPS/Heading Sensor is based upon a Crescent Vector High performance GPS Heading and Positioning module. This module computes heading and position using two antennas at some distance up to 2 meter apart. This design provides precise heading with an accuracy of 0.5 degr @ 95% with an antenna separation of 0.5 m. and GPS sub meter positioning accuracy even while at rest. The accuracy will increase with an increase of the antenna separation up to a maximum of 2 m, but with the trade off of slower acquisition and re-acquisition times.

And with integrated SBAS support, you can receive precision guidance anywhere those services are available. An internal gyro will provide an Angle of Roll Signal, which can be used to measure the Angle of Roll of the platform, if the sensor is properly installed in the right direction. The communication with the host computer is performed using a RS-232 serial data format following NMEA protocol and an update rate of 20 Hz maximum for the Heading information and 5 Hz for the position.

5.1.2.2 Barometric pressure

By means of an absolute pressure sensor the barometric pressure i.e. barometric altitude will be measured. The selected sensor has a build in microprocessor to compensate the signal for temperature effects. This sensor has as well an RS-232 serial as an analogue output and therefore can be easily connected to either the GNCS or Data Acquisition system.

5.1.2.3 Radar Altimeter

The Radar Altimeter will provide the System Altitude above ground level. This altitude information will be used to initiate the flare at an altitude of approximately 25-30 meter. The output of the system is a RS-232 compatible data stream. The radar altimeter will start at around 500 m above ground.

6 Actuator System

An actuator system is required for driving the steering manoeuvres during the gliding descent as well as to carry out a one-time flaring approach when landing. Actuators are operated to rewind or release the steering ropes of the parafoil, what causes either a direction change or the braking of the foil.

The actuator system as proposed for FastwingCL consists of two identical systems, i.e. a servo controller (so called servo amplifiers or servo drives) and a gear motor that drive a winch on which the steering ropes are wound. Figure 3 shows the layout of the actuator system.

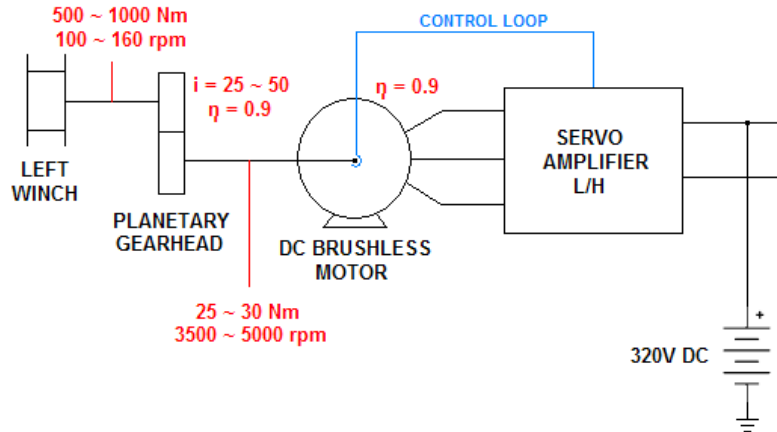

Figure 3 Layout of Actuator System

The actuator servo controller receives actuation commands from a host computer, that is either the GNCS computer (onboard the Platform) or the remote control equipment on ground. This controller contains the PID algorithms besides the power conversion stages. The feedback signal is provided by synchronous resolvers integrated inside the motors. Besides generating a signal speed, the relative position of the motor shaft is also read. The gear motor comprises the electrical motor, the reduction gearbox (planetary type) and the winch.

A multi-turn potentiometer is mounted on each gearbox shaft to measure the absolute position of the winch. This potentiometer signal will be used not used in the control loop, but is only added for homing purposes and data analysis.

Both for steering as well as for flare, a very high power is demanded for short periods (typically 1-2 seconds). In between these periods the system is resting. The two-sided flare is the most critical part of the actuation since it demands 8 times more energy than the single-sided steering actions. Since the system is designed for flare, it will definitely satisfy the demands for the steering actions

As the motion starting (acceleration ramp) the external load is minimum (see Figure 4) and the commanded motor speed is reached since it only has to overcome the system inertias, which have been neglected. Once overcome this initial transient, the motor is obliged to follow the “oblique” path parallel to the right boundary of performances curve due to the conjunction of voltage limitations with the rise of load:

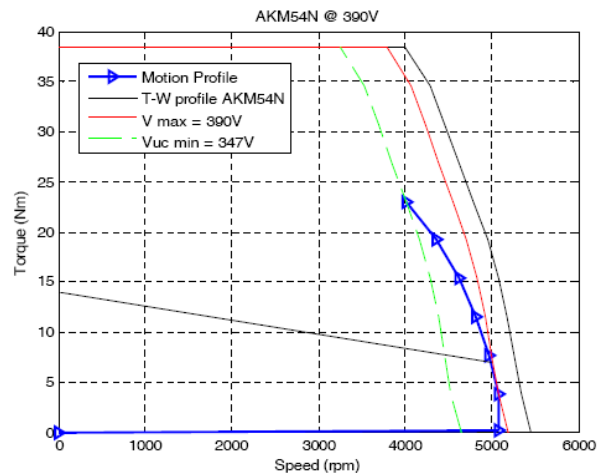

Figure 4 Torque as function of Speed



This phase actually constitute the mid section of the three section speed profile. Note that motor passes over the upper boundary of the continuous duty region and enters the intermittent zone

During motor deceleration or a downward motion of the motor load, conversion of the system's mechanical energy (kinetic and potential) will be regenerated via the servo amplifier or drive back onto the supply bus in the form of electrical energy.

In the FASTWing application, it is not the intention to make a later use of this energy since the power supply unit is designed to act as an energy capacitor when this reverse energy flow occurs.

Moreover, this regenerative process can charge the capacitor in the supply bus to potentially dangerous voltages or voltages that may cause an amplifier over-voltage shutdown condition. Thereby, this energy will be dissipated by a resistor that is managed by a trigger circuit, which in turn is activated when the DC Bus voltage exceeds certain value. Fortunately, our application is characterized by a very low inertia load, what alleviates tremendously the regenerating effects. In effect, the parafoil mass can be neglected from an actuation point of view, and only drive train inertias plays a significant role on the motion transients. Thereby, kinetic and potential energy due to inertial loads are notably reduced in comparison to typical industrial application with hanging masses or large flywheels. The need for an external resistor since the power dissipation capabilities of the selected servo controller appear to be insufficient to cover the regeneration demands specified.

7 Power Supply

Both the one-sided steering actions and the two-sided flare manoeuvre demand a very high electrical power for a short duration of time. Since the efficiency of electrical servo motors increases with the bus voltage a 390 VDC bus voltage was chosen to keep the electrical currents low and the energy losses to a minimum. However, in order to realize a 390 VDC bus voltage and also to facilitate high electrical peak powers, a cumbersome large array of low-voltage batteries is needed, connected both in parallel and in serial. The total weight of such a battery array will be well over 125 kg! Moreover, a careful charging procedure and a stringent maintenance schedule are required to keep the batteries in good working condition.

The main drawback of such a battery array is that it is extremely wasteful with respect to the amount of energy it accumulates. It holds more than 60 times the energy than that is needed for the complete flight profile, including the flare. Novel Ultra Capacitor technology enables a high bus voltage without the need for an excessively large battery array. The Ultra Capacitor is an electrical storage device that can hold a limited amount of energy but can supply an almost

unlimited amount of power for the short duration of the steering actions and flare manoeuvre. In contrast to batteries of which the energy storage and retrieval involves chemical reactions, the Ultra Capacitor holds the electrical charge over an ultra-thin dielectric medium, allows a virtually unlimited number of charging/recharging cycles and is completely maintenance free.

Instead of the high-voltage battery pack, a set of two standard liquid gel lead-acid 12 VDC batteries is used that only hold the energy needed for the complete flight profile with some reserves. A high-voltage charger is used to charge the Ultra Capacitor. In between these periods the system is resting. The Ultra Capacitor, chosen to have enough electrical storage capability to execute a full-stroke steering action and the flare, is able to supply these peak power demands and is recharged to its full capacitance in between the steering actions. The two-sided flare is the most critical part of the actuation since it demands 8 times more energy than the single-sided steering actions. Since the system is designed for flare, it will definitely satisfy the demands for the steering actions.

The principle of operation of the Ultra Capacitor solution is shown in Figure 5.

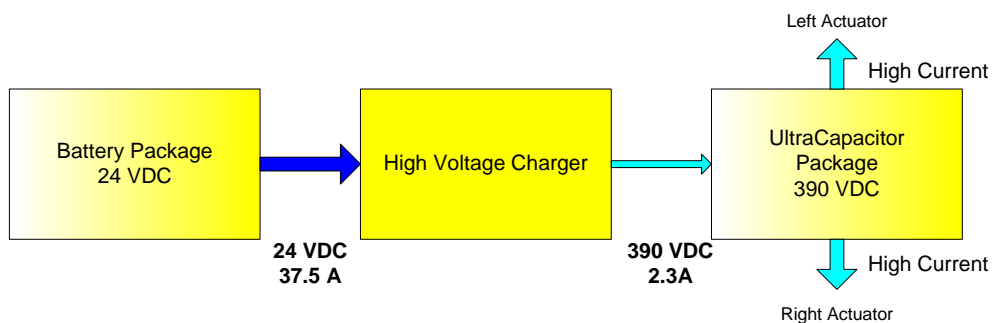

Figure 5 Block diagram of the Ultra Capacitor based solution

The 24 Volt DC batteries supply the current to the high-voltage charger, which charges the Ultra Capacitor to its maximum 390 Volt level. The capacitor supplies the current to the servo controllers, which drive the left and right steering line servo actuators. The actuators, in turn, rotate the winches through a planetary reduction gear.

The Ultra Capacitor, operating at 390 Volts, consists of 26 units of 15 Volts and 58 Farad, each. The net capacitance of this unit was rated at 1.78 Farad. The unit had a weight of 14.7 kg and a volume of 14.7 liters.

7.1 Energy and power demand considerations

Figure 6 shows the linear relation between the steering line force and the steering line displacement. The figure shows that the "spring constant" of the steering system is 2000 N m⁻¹. One-sided steering actions require a maximum displacement of 1.5 meters and a force of 3000

N, which is to be executed in one second. The two-sided flare action requires a maximum displacement of 3 meters and a force of 6000 N, to be executed in 2 seconds. Taking into account mechanical energy losses of 50%, each steering action will require an energy of 4.5 KJ, whereas the flare action will require 36 KJ.

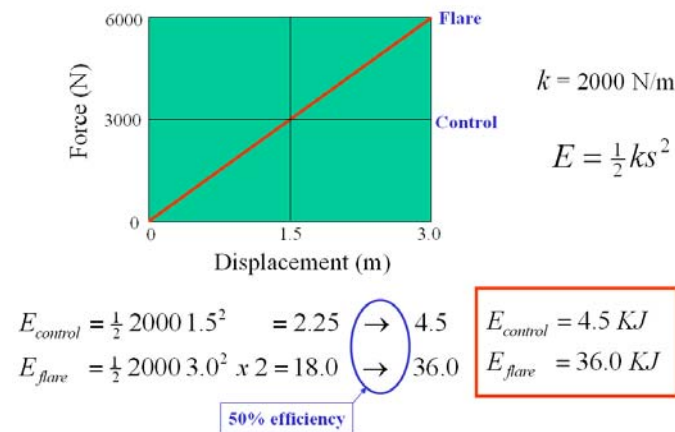

Figure 6 Energy requirements for steering control and flare actions

The electrical energy required for 25 steering actions and one flare action, taking into account a 50% efficiency of transferring electrical into mechanical energy, will be 297 KJ. In principle, this energy can be supplied by two 12 Volt DC 9 Ampere-hour sealed lead-acid (gel) FAA approved batteries, having a total weight of 12 kg. These batteries hold a total electrical energy of 778 KJ or almost three times more than is needed. Although this modestly sized battery pack is able to amply supply the total energy demands, it is unable to supply the instantaneous peak power demands. Numerical simulations of the servo system actions have shown that the peak power demands during flare can reach 18 kW. For a 24 Volt battery this would require an unacceptable current of 750 Amperes.

There are two alternative solutions to this problem:

1. To use the earlier mentioned cumbersome large array of 24 Volt 9 Ampere-hour batteries connected in series, which yields a higher voltage and a lower and acceptable current;
2. To employ an Ultra Capacitor to supply the peak power demands.

Solution (1) is highly impractical, since it would require almost 20 batteries in series to bring the current within manageable limits of 40 Amps. As mentioned earlier, these batteries also hold 60 times more energy than what is needed for the complete flight profile, including flare and have a weight of 125 kg.

For solution (2) the Ultra Capacitor weighs only 14.7 kg, two 12 Volt DC 9 Ampere-hour batteries weigh 12 kg and the high-voltage charger weighs 10 kg, giving a total of 36.7 kg.



Therefore the latter solution has been chosen as the optimal energy/power alternative for the Fastwing CL power system. It should be noted that this design is based on off-the-shelf components. Custom-tailored design of the high-voltage charger and the use of batteries with a higher energy density, will yield additional reductions in weight.

As mentioned before, each steering action requires a mechanical energy of 4.5 KJ, or an electrical energy of 9 KJ, taking into account a 50% efficiency of transforming electrical into mechanical energy. This steering action will be performed in 1 second, requiring an average current of 23 Amps and a peak current of 40 Amps. The Ultra Capacitor is designed to supply this current. Its internal resistance is virtually zero and it is able to supply currents of up to 2000 Amps. Following the control action, the voltage of the Ultra Capacitor will drop from 390 Volts to 378 Volts. This voltage drop has no effect on the performance, since the servo actuators are able to operate at a voltage level as low as 280 Volts. In between the steering action, the Ultra Capacitor will be recharged to its full capacitance. The system is designed to replenish the capacitor within 10 seconds. Thus the average power required for the recharge is 900 Watts or 2.3 Amps at the high voltage and 37.5 Amps at the low voltage. The latter amperage is fully acceptable for the low-voltage batteries.

8 TeleCommand/Telemetry System

A bidirectional TeleCommand/Telemetry system will allow sending TeleCommands from the Ground Based Control Station (GBCS) to the GNCIU. This will be used to remotely pilot the system or to initiate the emergency sequence if necessary. Therefore a handheld remote control unit will be attached to the GBCS.

The same data link will be used to transmit messages from the vehicle to the Ground based Control Station and will be used to monitor status and behaviour of the vehicle in flight for:

- Safety reasons
- Support of the pilot with track and attitude parameters during remotely controlled operations

A number of essential parameters will be transmitted to the GBCS, e.g.

- GPS position (Latitude, Longitude, Height and Velocity) and time
- True Heading
- Distance to Ground
- LH and RH Actuator positions
- Mission Time
- GNCS Guidance status

In the GBCS these parameters are processed and displayed in a suitable graphic and alphanumeric format.

The system consists of two modems that allows for bi-directional communications. Thereby the ground unit will be the master and the unit in the vehicle will act as slave unit. An additional amplifier will boost the transmitter output up to increase the reliability at larger distances. The communication protocol uses an RS-232 format @ 19,200 kps. This will allow for a parameter update rate of 5Hz

9 Integration

All systems, dealing with the guidance, navigation and control function will be installed in one frame, Steering box (see Figure 7). On the left and right side the actuator system will be installed, while the power supply (energy box) and GNCCS will be installed in the middle section. On top of the box the Emergency system and the Flight Data Acquisition System will be mounted.

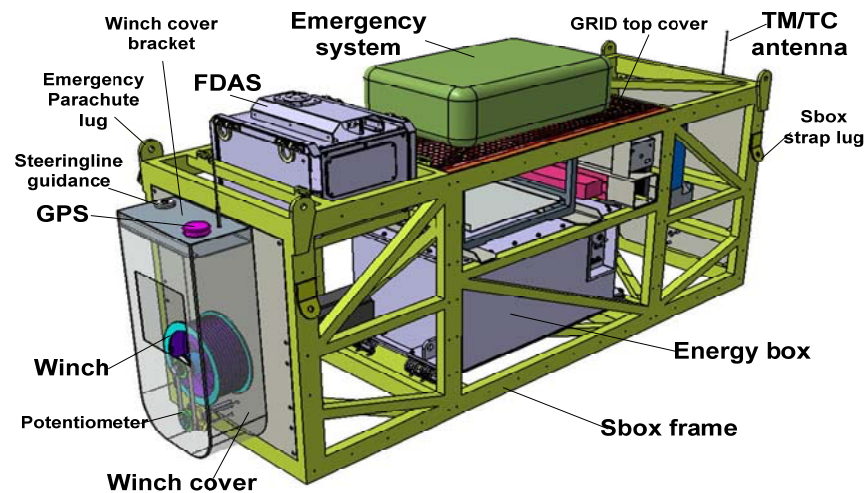

Figure 7 Layout of Steering Box

During the activation of the emergency system, the entire box is disconnected from the main pallet and a separate parachute will be deployed that have to guarantee a smooth landing of the entire system.

10 System test

The Guidance, Navigation & Control Computer has been tested in the laboratory using a second computer system that was simulating the parafoil behaviour during flight. This software accepted the commanded actuator movements and outputs position and heading changes to the Guidance, Navigation and Control Computer

10.1 Closed loop laboratory test

The Guidance, Navigation & Control Computer has been tested in closed loop in the laboratory using a laptop computer that was used to simulate the parafoil behaviour during flight (see Figure 8).

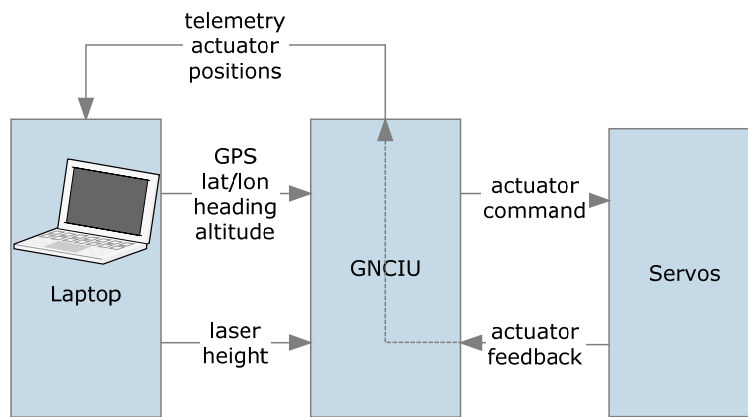

Figure 8 Wiring diagram for the hardware-in-the-loop test

The simulation software accepts the actual actuator positions and outputs simulated position, velocity and heading to the Guidance, Navigation and Control Computer.

The parafoil simulation software is implemented in Matlab/Simulink while the (simulated and actual) autopilot software is implemented in C.

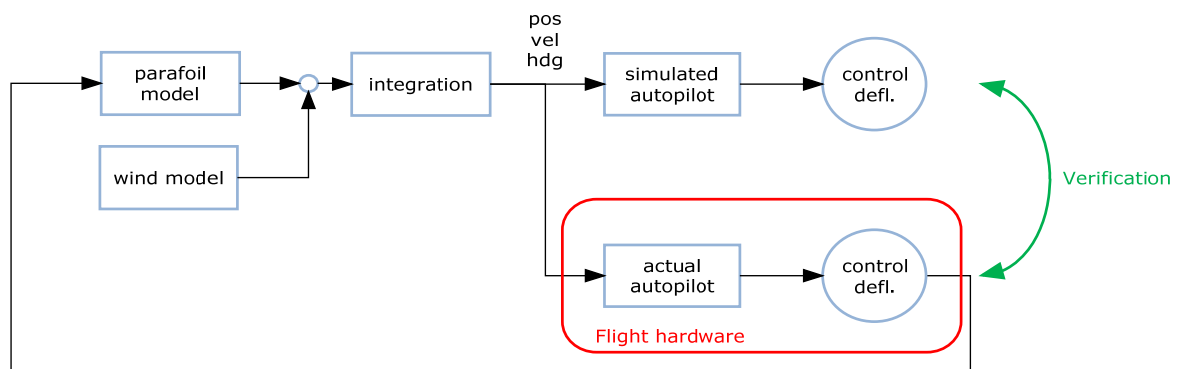

Figure 9 Verification of actual autopilot software using a hardware-in-the-loop closed loop test

As shown in Figure 9 the Hardware-in-the-loop (HIL) test is used to verify the implementation of the flight software by comparing it with the reference autopilot implemented in the simulation.

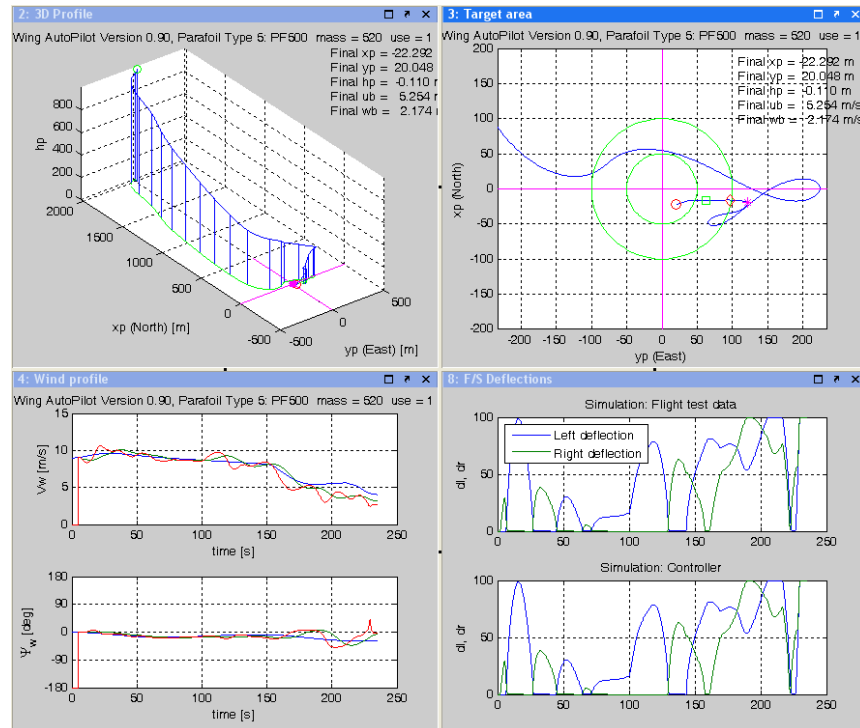

Figure 10 Example of hardware-in-the-loop test

Figure 10 gives a typical example of the results of a hardware-in-the-loop test. The trajectory was a drop from 1000 m as shown in the upper left plot. The final landing accuracy is shown in the upper right plot. The lower left plot shows the simulated wind magnitude and wind direction. The simulated varying wind is the blue line and the green line is the autopilot estimate of the wind. The lower right plot shows the (commanded and actual) actuator deflections in cm. Note that this example shows the result for a preliminary parafoil aerodynamic model based on experience with previous heavy parafoils.

10.2 Actuator/Power Supply Test

A series of test bench experiments were executed with the Ultra Capacitor driven actuation system, simulating a steering action under load. The two motors were mounted next to each other on a test rig with their axes parallel. See Figure 11 for an impression. The orange unit is the Power Supply Box.



Figure 11 Actuator/Power Supply Test bench

One servo motor acted as the actuator, and the other one as the load. A steering line was looped around the winches of each motor to make the mechanical connection between the motors. Since only one actuation motor was operated, the energy that was generated by the second motor, was dissipated in a load resistor. The purpose of this test was to verify that the actuation motor is able to perform the flare even if the bus voltage drops to as low as 275 VDC. Figure 12 shows the test bench results for a two-sided flare action.

The lower part of the figure shows the actuator displacement. Four flare actions were simulated, each of which starting at a different bus voltage. The forward stroke was performed in 2.5 seconds while the backstroke was performed deliberately slower. The figure shows that a lower bus voltage does not deteriorate the flare performance.

The upper part of the figure shows the Ultra Capacitor voltage. The time axis is subdivided in sections denoted by the letter “A” and “B.” In sections “B” the Ultra Capacitor was intermittently discharged through a load resistor in order to deliberately lower the bus voltage to the required value, i.e. 330 VDC, 310 VDC, etc. In sections “A” the Ultra Capacitor voltage drops as a result of the forward stroke and increases again during the backstroke as a result of the recharging cycle. It should be noted that for safety reasons the back stroke energy was not returned to the Ultra Capacitor but rather dissipated in a load resistor. It is in principle possible to recapture the backstroke energy, but this would require a more sophisticated energy management scheme which has a higher sensitivity to malfunctions.

The results clearly show the main advantage of the use of an Ultra Capacitor. It meets the high peak power demands of the actuation system and holds more than enough energy to perform one steering action, while it recharges itself in the resting periods between actuations. In summary, the Ultra Capacitor driven system is based on low-cost low-maintenance and robust standard lead-acid batteries with a weight and volume that is a fraction of the high-voltage battery array. Extensive discharge/charge tests with load resistors simulating the various flight profiles, have demonstrated the robustness and reliability of the system.

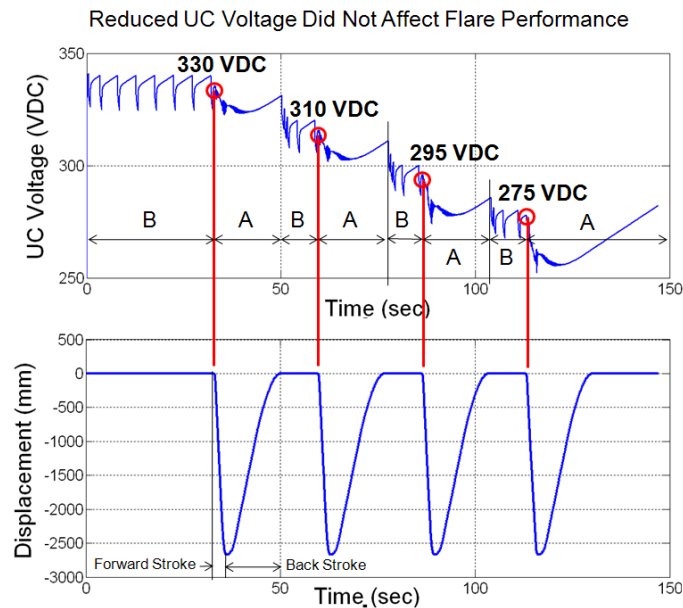

Figure 12 Test bench results for flare action under load

10.3 Flight tests

During the initial drop test that will take place at ranges in the USA, a number of test will be performed to optimize a number of parameters in the guidance process. Test will include Open Loop test and Closed Loop test. After that a series of flight test will be performed at several release altitudes and weight.

10.3.1 Open Loop Test

The algorithms in the guidance software are strongly dependent on the dynamic behaviour of the parafoil. Since the parafoil as used in the FASTWing CL program is a new design, less information on the behaviour is available. Currently the algorithm will be based upon information that is derived from mass, moment of inertia etc. During a number of flight test the proper parameters for the guidance algorithm will be optimized. A number of dedicated parameters will be recorded during the tests. After the tests, these data will be analysed in order to determine the dynamic characteristics of the system. Autonomous control will be limited to a predefined sequence of actuator commands, without automatic feedback (hence the name Open Loop). It will be possible to override the autonomous control with the remote control unit.

10.3.2 Closed loop test

In the Closed Loop Drop Test (CLDT), the guidance algorithm in the Guidance, Navigation and Control Unit will autonomously control the steering lines. This algorithm will be able to guide the system towards a predefined landing spot. The steering commands will be based on the feedback supplied by the on-board sensors (hence the name Closed Loop). Similar to the



OLDT, it will be possible to override the autonomous control function via the remote control unit on the ground. This test shall prove that the system is able to steer the parafoil system towards the pre-programmed landing point and land with an accuracy within 100 m.

11 Conclusions

The system as presented in this publication has not yet flown. However extensive laboratory tests have been performed and these tests have shown that the system is ready to be installed on the payload. Flight tests are scheduled for March 2010 at the Kingman range, USA.