

Syddansk Universitet

CT assessment of early response to neoadjuvant therapy in colon cancer

Rafaelsen, Søren Rafael; Dam, Claus; Lund-Rasmussen, Vera; Pløen, John; Jakobsen, Anders

Publication date:
2016

Document Version
Publisher's PDF, also known as Version of record

[Link to publication](#)

Citation for published version (APA):
Rafaelsen, S. R., Dam, C., Lund-Rasmussen, V., Pløen, J., & Jakobsen, A. (2016). CT assessment of early response to neoadjuvant therapy in colon cancer. Poster session presented at 8th European Multidisciplinary Colorectal Cancer Congress, Amsterdam, Netherlands.

General rights

Copyright and moral rights for the publications made accessible in the public portal are retained by the authors and/or other copyright owners and it is a condition of accessing publications that users recognise and abide by the legal requirements associated with these rights.

- Users may download and print one copy of any publication from the public portal for the purpose of private study or research.
- You may not further distribute the material or use it for any profit-making activity or commercial gain
- You may freely distribute the URL identifying the publication in the public portal ?

Take down policy

If you believe that this document breaches copyright please contact us providing details, and we will remove access to the work immediately and investigate your claim.



Abstract Book Posters

**8th European Multidisciplinary
Colorectal Cancer Congress**

11 - 13 december 2016

RAI Amsterdam, the Netherlands



Posters

P01

Legal and financial consequences of clinical errors in diagnosis and management of colorectal disease

F.D. Skidmore

Wellington Hospital, LONDON, United Kingdom

Objectives:

To identify the reasons why there are failures of the clinical management process of patients with symptoms suspicious of primary or recurrent colorectal cancer. These failures lead to delayed diagnosis, unnecessary morbidity and enhanced mortality. In addition to patient pain and suffering there are major financial and professional implications for hospitals and Consultants who are found to be legally responsible for preventable errors.

Methods:

95 medicolegal cases reported upon by the author (2006-2016) are reviewed and discussed. Errors and delays in diagnosis occur at general practice, gastroenterology, diagnostic radiology, surgical and clinical oncologist components of integrated care. There are biopsy and pathological sampling errors in the investigative process. The paper apportions responsibilities to these groups. There are non-clinical administration failures in data transfer, document filing and appointment scheduling.

Conclusions:

Poor communication between professionals whether clinical or administrative is common.

There is lack of continuity of care between involved clinicians because of staff rotas and shifts during the patient's stay in hospital.

Patients therefore receive false reassurance about their clinical status which they do not question when new symptoms indicative of disease progression present.

Serious untoward incident (SUI) retrospective assessment of clinical errors can result in suspension of doctors' practicing privileges.

Many basic errors occur because clinicians fail to remember student level clinical teaching and bedside observational medicine.

These problems are increasing with progressive sub-specialisation in secondary care and reliance on imaging and electronic data processing.

The overall cost to national health services of clinical errors is estimated to be more than 5% of total budget.

P02

Exome Sequencing Identifies a Novel Recessive Subtype of Colorectal Adenomatous Polyposis

R.S. Adam¹, I. Spier², B. Zhao³, M. Kloth⁴, I. Hinrichsen⁵, J. Marquez³, J. Kirfel⁴, A. Tafazzoli², S. Horpaopan⁶, S. Uhlhaas², D. Stienen², N. Friedrichs⁴, J. Altmüller⁷, A. Laner⁸, S. Holzapfel², S. Peters², K. Kayser², H. Thiele⁷, E. Holinski-Feder⁹, G. Marra¹⁰, G. Kristiansen⁴, M.M. Nöthen², R. Büttner⁴, G. Möslein¹¹, R.C. Betz², A. Brieger⁵, R.P. Lifton³, S. Aretz²

¹Academic Medical Center, AMSTERDAM, Netherlands

²Institute of Human Genetics, BONN, Germany

³Howard Hughes Medical Institute, YALE, USA

⁴Institute of Pathology, COLOGNE, Germany

⁵Medical Clinic 1, University Hospital Frankfurt, FRANKFURT, Germany

⁶Faculty of Medical Science, Naresuan University, PHITSANULOK, Thailand

⁷Cologne Center for Genomics, COLOGNE, Germany

⁸Medizinische Klinik und Poliklinik IV, Ludwig-Maximilians-University (LMU), MUNICH, Germany

⁹Medical Genetics Center, MUNICH, Germany

¹⁰Institute of Molecular Cancer Research, ZURICH, Switzerland

¹¹HELIOS Klinikum Wuppertal, University of Witten/Herdecke, WUPPERTAL, Germany

Background: In around 30% of families with colorectal adenomatous polyposis, no causative germline mutation in the known genes *APC*, *MUTYH*, *POLE*, *POLD1*, or *NTHL1* can be identified, although a hereditary etiology is likely.

Methods: To uncover further genes with high-penetrance causative mutations, we performed exome sequencing of leukocyte DNA from 102 unrelated individuals with unexplained adenomatous polyposis. For data analysis and variant filtering, an established bioinformatics pipeline including in-house tools was applied. For selected cases, further examinations were performed on RNA blood samples and formalin-fixed paraffin-embedded tissues.

Results: We identified two unrelated individuals with differing germline mutations in the mismatch repair gene *MSH3*. Each patient carried two loss-of-function mutations affecting both *MSH3* alleles constituting a compound-heterozygous genotype (Figure 1). The impact of the *MSH3* mutations (c.1148delA, c.2319-1g>a, c.2760delC, c.3001-2a>c) was indicated on RNA and protein level as shortening of the transcript and/or protein. Analysis of the diseased individuals' tumor tissue demonstrated high microsatellite instability of di- and tetranucleotides (EMAST) and immunohistochemical staining illustrated a complete loss of nuclear MSH3 in normal and tumor tissue,

confirming the loss-of-function effect and causal relevance of the mutations. The pedigrees, genotypes, and the frequency of *MSH3* mutations in the general population are consistent with an autosomal recessive mode of inheritance. Both index persons had an affected sibling carrying the same mutations. The tumor spectrum in these four persons comprised colorectal and duodenal adenomas, colorectal cancer, gastric cancer, and an early-onset astrocytoma (Figure 1). Besides, we identified compound-heterozygous germline mutations in the mismatch repair gene *PMS2* in one unrelated individual of our cohort. Biallelic mutations in *PMS2* are known to cause a syndrome termed Constitutional Mismatch Repair Deficiency Syndrome (CMRRD) characterized by a broad tumor spectrum with onset in childhood, often involving (multiple) colorectal tumors.

Conclusions: The present study is the first to identify biallelic pathogenic germline mutations of the DNA repair gene *MSH3* in patients with a suspected hereditary tumor syndrome. Our data suggest that the reported *MSH3* mutations cause an additional recessive subtype of colorectal adenomatous polyposis.

Figure 1: Pedigrees of the two index persons with biallelic *MSH3* germline mutations. A. Pedigree of first family (ID 1275), B. Pedigree of second family (ID 1661). Above the symbols, identifiers are given for affected individuals. The number on the upper right side of a symbol displays the age at death, or in living persons, the age at last contact. On the lower right, genotype and phenotype information are displayed. The numbers following a disease represent the age at first diagnosis. ad. = adenomas; CRC = colorectal carcinoma; CUP = cancer of unknown primary; duod. = duodenal; GC = gastric cancer; LC = lung cancer; polyps = multiple colorectal adenomatous polyps; yrs = years. Adapted from: Adam et al., Exome Sequencing Identifies Biallelic *MSH3* Germline Mutations as a Recessive Subtype of Colorectal Adenomatous Polyposis. Am J Hum Genet. 2016;99(2):337-51.

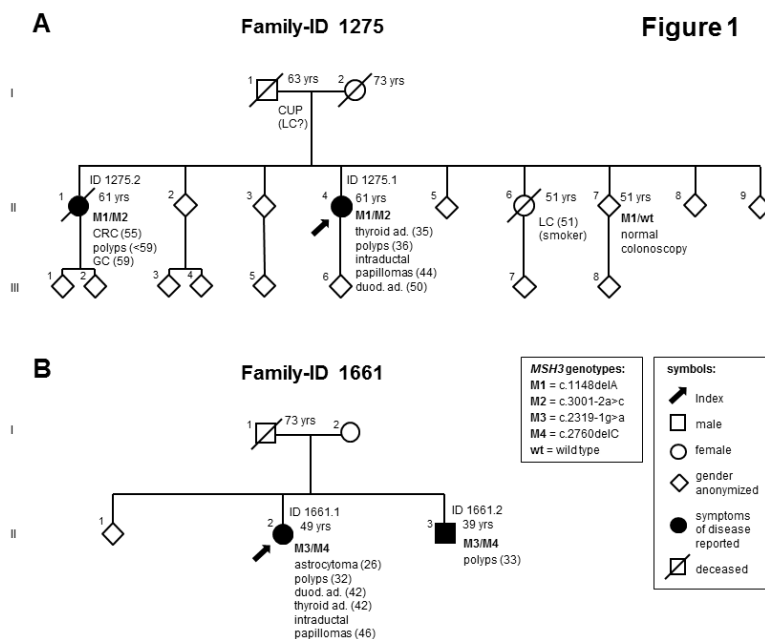

Figure 1: Pedigrees of the two index persons with biallelic *MSH3* germline mutations.

P03

SYK(S) isoform is a prognostic marker for short liver metastasis free survival in patients with lymph node negative colon cancer

R.R.J. Coebergh van den Braak¹, A.S. Sieuwerts¹, Z.S. Lalmahomed¹, S. Bril¹, A.M. Timmermans¹, V. De Weerd¹, M. Van der Vlugt-Daane¹, A. Van Galen¹, S. Xiang¹, K. Biermann¹, J.H. Van Krieken², J.W.M. Martens¹, J.A. Foekens¹, J.N.M. IJzermans¹

¹Erasmus MC - University Medical Center, ROTTERDAM, Netherlands

²Radboud University Medical Center, NIJMEGEN, Netherlands

Objectives: Surgery without adjuvant therapy is the current treatment for lymph node negative colon cancer. However, 20% of these patients will develop recurrence of disease. Identification of these patients is an unmet need. Spleen Tyrosine Kinase (*SYK*) gene has been described both as tumor promotor and tumor suppressor in epithelial malignancies, and is part of the recently published consensus molecular subtypes signature. *SYK* has 4 splice variants coding for 2 isoforms, *SYK* short [*SYK(S)*] – which misses exon 7 and therefore part of interdomain B – and *SYK* long [*SYK(L)*]. This is the first study to assess the prognostic value, i.e., the natural course of the disease, of mRNA of *SYK* and its splice variants in primary lymph node negative chemo-naïve colon cancer.

Methods: Patients were recruited from the MATCH study, a prospective colon cancer cohort study. The total mRNA

expression of SYK(T) and the expression of its two splice variants SYK(S) and SYK(L) were measured using RT-qPCR in a clinically well-defined cohort of 240 colon cancer patients, including 160 untreated lymph node negative[LNN] and 80 adjuvant treated lymph node positive[LNP] patients and related to disease free (DFS), hepatic metastasis free (HFS) and overall survival (OS). KRAS mutation status and microsatellite instability (MSI) were determined as well.

Results: increased SYK mRNA expression levels were associated with stage I/II, left-sided, microsatellite stable, predominantly epithelial and KRAS-mutated tumors (**Table 1**). In the total group, univariate Cox regression analysis using continuous mRNA expression levels showed that increasing SYK(S) mRNA expression levels were associated with reduced HFS (Hazard Ratio [HR]=1.63; 95% Confidence Interval [CI]=1.01-2.62; p=0.045). In the LNN sub group, a similar association with HFS was observed for SYK(S) mRNA expression levels (HR=2.21; 95%CI=1.20-4.08; p=0.011) (**Figure 1**) and SYK(T) mRNA expression levels (HR=2.10; 95% CI=1.07-4.12; p=0.03). No significant association between HFS and SYK(T), SYK(S) or SYK(L) mRNA expression levels were observed nor between DFS and OS and SYK(T), SYK(S) or SYK(L) mRNA expression levels in the total, LNN or LNP group. These results in chemo-naïve LNN colon cancer patients indicate a pure prognostic role for SYK(S) mRNA.

Discussion/conclusion: This study shows that mRNA levels of SYK(T) and more specifically SYK(S) are pure prognostic markers for hepatic metastases in primary LNN chemo-naïve colon cancer patients. These results may help to identify patients at risk to develop liver metastases in this group of low risk patients. Future studies are needed to validate the prognostic value and biological significance of SYK(S) for the development of hepatic metastases.

Table 1. Clinical and histopathological characteristics and SYK mRNA expression

			SYK(T)			SYK(S)			SYK(L)					
			Median	IQR	P-value	Median	IQR	P-value	Median	IQR	P-value			
Total group	Tumor stage	Stage I	60	25.0%	-4.31	1.04	0.31	-4.62	1.25	0.037	-4.73	0.98	0.448	Jonckheere- Terpstra test
		Stage II	100	41.7%	-3.96	1.09		-4.61	1.29		-4.54	1.08		
		Stage III	80	33.3%	-4.15	0.91		-4.98	1.51		-4.81	0.97		
	Location	Right	121	50.4%	-4.24	1.02	0.015	-4.89	1.43	0.004	-4.84	1.00	0.008	Mann-Whitney U
		Left	119	49.6%	-4.01	0.94		-4.52	1.37		-4.62	0.83		
	MSI-status	MSS	190	79.2%	-3.96	0.98	<0.001	-4.46	1.29	<0.001	-4.63	1.04	<0.001	Mann-Whitney U
		MSI	49	20.4%	-4.59	0.77		-5.34	0.91		-5.05	0.95		
	Epithelial marker	mRNA EPCAM expression*	240	100%	0.47		<0.001	0.58		<0.001	0.41		<0.001	
	Epithelial-to-mesenchymal transition	EMT-index**	240	100%	-0.15		0.003	-0.21		0.001	-0.03		0.68	
	LNN group	Tumor stage	Stage I	60	37.5%	-4.31	1.04	0.036	-4.62	1.25	0.92	-4.73	0.98	0.012
Stage II			100	62.5%	-3.96	1.09		-4.61	1.29		-4.54	1.08		
Stage III			-	-	-	-	-	-	-	-	-	-	-	-
Location		Right	82	51.3%	-4.16	1.22	0.16	-4.79	1.3	0.015	-4.77	1.18	0.14	Mann-Whitney U
		Left	78	48.8%	-4.04	0.98		-4.37	1.31		-4.58	0.90		
MSI-status		MSS	122	76.3%	-3.94	1.01	<0.001	-4.29	1.24	<0.001	-4.56	1.03	<0.001	Mann-Whitney U
		MSI	37	23.1%	-4.59	0.89		-5.31	0.81		-4.99	1.04		
Epithelial marker		mRNA EPCAM expression*	240	100%	0.47		<0.001	0.55		<0.001	0.36		<0.001	
Epithelial-to-mesenchymal transition		EMT-index**	240	100%	-0.15		0.054	-0.18		0.023	-0.03		0.72	
LNP group		Location	Right	39	48.8%	-4.29	0.98	0.020	-5.25	1.54	0.07	-5.09	1.05	0.009
	Left		41	51.3%	-3.95	0.87		-4.70	1.26		-4.65	0.76		
	MSI-status	MSS	68	85.0%	-4.02	0.90	0.002	-4.71	1.40	0.001	-4.76	0.88	0.15	Mann-Whitney U
		MSI	12	15.0%	-4.59	0.52		-5.72	1.28		-5.19	0.76		
	Epithelial marker	mRNA EPCAM expression*	240	100%	0.51		<0.001	0.59		<0.001	0.39		<0.001	
	Epithelial-to-mesenchymal transition	EMT-index**	240	100%	-0.14		0.22	-0.29		0.01	-0.01		0.93	
TCGA	KRAS-mutation	Wild type	136		-0.16	1.13	<0.001							
		Mutant	79		0.37	1.13								

mRNA expression levels are shown as median with the interquartile range. For the MATCH cohort, mRNA expression levels were normalised using the average of three housekeeper genes (HMBS, HPRT1 and TBP). The TCGA data is Agilent microarray data compared to the expression distribution of each gene of tumors that are diploid for this gene.

** n=1 missing

* Spearman's rho

^ EMT-index=(VEGFA - EPCAM + VIM + CDH2 + FN1 + IGF1 + IGF2 + BGN + FAP + INHBA + TGFB1 - ESR1 - ESR2)/13. A high EMT-index means a predominantly mesenchymal tumor while a low EMT-index means a predominantly epithelial tumor.

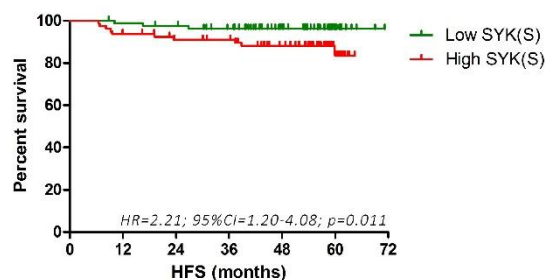

Nr, at risk	0	12	24	36	48	60	72
Low SYK(S)	81	79	77	71	49	19	0
High SYK(S)	79	73	67	65	50	16	0

P04

The prothrombin 3' end gene variants in sporadic colon adenocarcinoma

B. Tomic¹, I. Pruner¹, T. Jovanovic¹, M. Gvozdenov¹, G. Aralica², D. Radojkovic¹, S. Kapitanovic³, T. Cacev³, V. Djordjevic¹

¹Institute of molecular genetics and genetic engineering, University of Belgrade, BELGRADE, Serbia

²University Hospital Dubrava, Medical School University of Zagreb, ZAGREB, Croatia

³Rudjer Boskovic Institute, ZAGREB, Croatia

It was evidenced that thrombin has important roles in the proliferation and migration of cancer cells and metastases formation. However, the analogous mechanisms involving expression of the gene encoding for prothrombin (FII), the thrombin precursor, remain poorly understood. The 3' end of the prothrombin gene has non-canonical architecture that is sensitive to gain-of-function variants, leading to increased prothrombin expression. This study was aimed at the analysis of the 3' end prothrombin gene variants in colon adenocarcinoma tissue.

The study group consisted of 39 patients (19f/20m; 65.4±10.52y) who suffered from sporadic colon adenocarcinoma. The analysis has included 39 pairs of DNA samples originated from colon tumor and adjacent normal tissue from the Croatian Tumor Bank. Screening of the last intron and exon, 3'untranslated region and flanking region of prothrombin gene was performed by DNA sequencing.

We detected two prothrombin variants: FIIG20210A and FIIA19911G, in normal and/or tumor tissue samples of 25 patients. Among them, four patients displayed different tissues genotypes. One patient was heterozygous (normal tissue)/ homozygous (tumor tissue) for FIIG20210A mutation. Regarding FIIA19911G gene variant, two patients were heterozygous (normal tissue)/ non-carrier (tumor tissue) and one patient was heterozygous (normal tissue)/ homozygous (tumor tissue) carrier. Both detected gene variants are previously described and associated with elevated prothrombin gene expression.

In conclusion, this pilot study on prothrombin 3' end gene variants suggests its potential role in colon cancer etiology which remains to be further investigated.

P05

Multicentre clinical research in the Netherlands: an evaluation of the procedures for obtaining approval for local feasibility.

J. Huiskens¹, E.P. Van der Stok², B. Hemmes³, D.J. Grünhagen², T.M. Van Gulik¹, C. Verhoef², C.J.A. Punt¹

¹Academic Medical Center, AMSTERDAM, Netherlands

²Erasmus MC Cancer Institute, ROTTERDAM, Netherlands

³Comprehensive Cancer Centre Netherlands, UTRECHT, Netherlands

Introduction: The logistics of initiating clinical research in the Netherlands are becoming increasingly complex. Data on its consequences in clinical practice are scarce. In the current study, the procedures for obtaining approval for local feasibility of two national investigator-initiated, multicentre phase 3 studies in colorectal cancer were evaluated.

Method: The time intervals between the approval by the central Medical Ethics Committee (MEC) for participation of local centres and the receipt of the application file by the local centres as well as the receipt of the written local approval were examined for two investigator-initiated studies: CAIRO5 and CHARISMA of the "Dutch Colorectal Cancer Group" (Figure 1). The number and type of documents that were requested by each centre for their local approval as well as the amount of any fees charged for this procedure were evaluated.

Results: Procedures were analysed in 9 centres for the CHARISMA trial and in 19 centres for the CAIRO5 trial. The median time interval between the approval by the central MEC for participation of a local centre and the final approval for local feasibility by the Board of Directors was 90 days (range 4-312). The median time interval between receipt of the application file by a participating centre and their written confirmation of local approval was 21 days (range 3-178) (Table 1). The median number of documents required for local approval that were requested per centre was 10 (range 6-20). The charges by participating centres for this procedure was on average € 318 (range 0-1,750).

Conclusion: Our analysis of the procedures for obtaining approval for local feasibility of participating centres concerning two Dutch multicentre studies, showed a large variety in time, content and costs. This seriously hampers the conduct of clinical research, and therefore urgently warrants more simple and uniform regulations.

Time period	Days	
	Median	Range
A:		
All procedures	90	4-312
CAIRO5	136	4-312
CHARISMA	63	32-217
B:		
All procedures	64	2-308
CAIRO5	91	2-308
CHARISMA	60	15-116
C:		
All procedures	21	3-178
CAIRO5	21,5	3-178
CHARISMA	17	3-315
D:		
All procedures	68	3-351
CAIRO5	113	3-351
CHARISMA	41	9-78

Table 1: The median and range of time periods A, B, C and D (days) of all procedures in both trials and of CAIRO5 and CHARISMA trial, respectively.

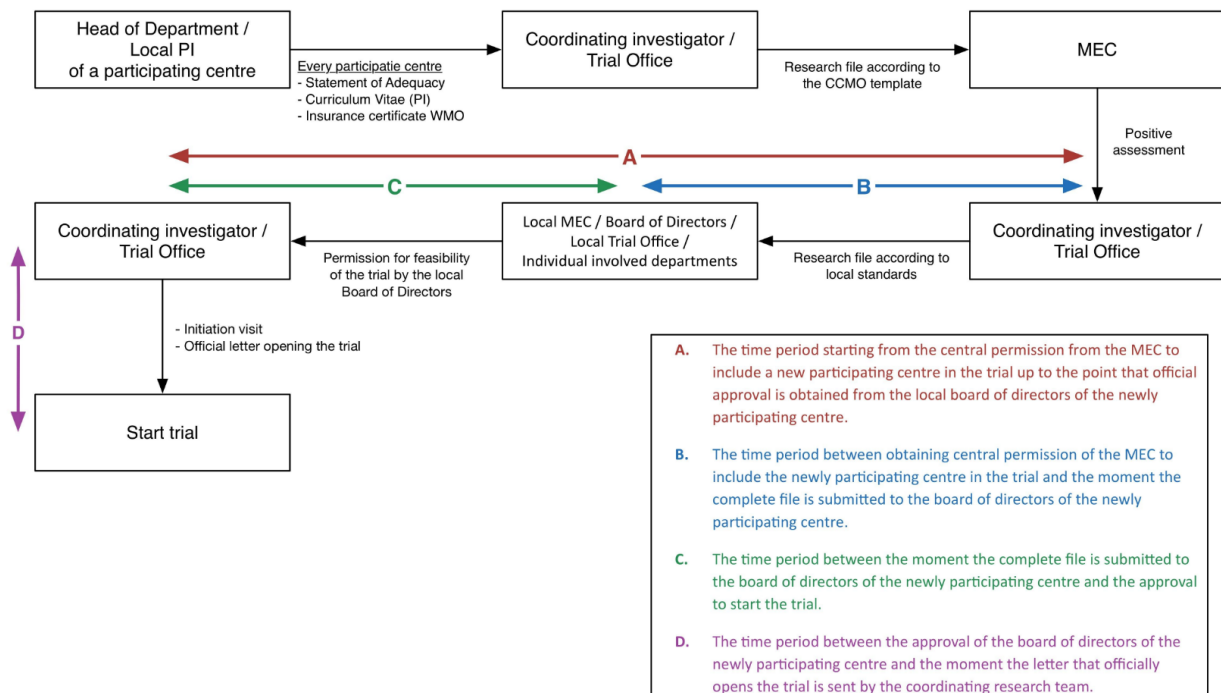

Figure 1: Overview of the procedure for obtaining approval to start a multicentre clinical trial in a participating hospital

P06

Pre-operative cell-free DNA and correlation with stage in rectal cancer

A.K. Boysen¹, Y. Wettergren², B.S. Sorensen¹, H. Taflin², B. Gustavson², K-L. G. Spindler¹

¹Aarhus University Hospital, AARHUS, Denmark

²Sahlgrenska University Hospital, GÖTEBORG, Sweden

Background: Accurate staging of rectal cancer remains essential for optimal patient selection for combined modality treatment, including radiotherapy, chemotherapy and surgery. Despite advances in modern imaging controversies exist especially regarding the nodal stage. The level of circulating cell-free DNA (cfDNA) has shown promising results as a prognostic marker in various settings of colorectal cancer management. The aim of this study was to analyze the correlation of cfDNA with the stage of rectal cancer patients at time of surgery.

Methods: Patients were selected from a database with biobanked blood samples at the Department of Surgery, Sahlgrenska University Hospital, Göteborg, Sweden. All patients were diagnosed with rectal adenocarcinoma and received pre-operative short course radiotherapy (25Gy/5F) (SCRT) or long course chemo-radiotherapy (52Gy/26F + capecitabine) (LCRT) as per national standard, followed by radical resection. Postoperative staging was performed according to the American Joint Committee on Cancer (AJCC). Blood samples for translational research were drawn prior to rectal surgery and collected in Histopaque, then centrifuged within 30 minutes and stored at -80°C until use. Cell-free DNA quantification was performed at Aarhus University Hospital, Aarhus, Denmark, using the QIAamp Circulating Nucleic Acid Kit (Qiagen) for DNA purification from 2 mL plasma. The level of cfDNA was quantified by digital droplet PCR (BioRad QX200) quantification of beta 2 microglobulin (B2M) and expressed as copies of (B2M) per ml.

Results: A total of 75 patients were included in the cohort and blood samples were available from 74 patients. The gender distribution was 59% male and 41% female with a median age of 68 years (range 35-85 years, 95% CI 64-70). All patients received pre-operative radiotherapy, including 84% as SCRT and 16% LCRT. All patients underwent a radical resection, and 25% had node positive disease. The median level of cfDNA levels in stages I-III were 3.100, 8.300 and 10.700 copies/mL, respectively. For node negative and positive disease the median B2M copy number were 2400 copies/mL (95%CI 2.300-3.300) and 4.400 copies/mL (95%CI 2.600-9.600) (p=0.04), respectively. The median follow-up was 39 months and 11 recurrences were detected (15%). The median cfDNA level for patients who experienced recurrent disease was 13.000 copies/mL (95%CI 1.400-26.000) compared to 5.200 copies/mL (95%CI 3.500-8.100) for non-recurrent patients (p=0,08).

Conclusion: We have demonstrated a correlation between the pre-operative cfDNA levels and rectal cancer stage. Furthermore, patients with node positive disease at time of surgery had significantly higher cfDNA levels, than those with node negative status, and high cfDNA levels seem to correlate to the risk of local recurrence. Consequently, the cfDNA levels at surgery could potentially contribute to more accurate preoperative staging and risk assessment in rectal cancer, and needs to be further investigated.

P07

The Prospective Dutch ColoRectal Cancer cohort (PLCRC) - a prospective nationwide observational cohort study

G.R. Vink¹, R.R.J. Coebergh van den Braak², C.J.A. Punt³, H.M. Verkooijen⁴, M.E. Noo⁵, G.A. Meijer⁶, M. Koopman⁴, On behalf Of the PLCRC working group⁷

¹Netherlands Comprehensive Cancer Organisation, UTRECHT, Netherlands

²Erasmus MC - University Medical Center, ROTTERDAM, Netherlands

³Academic Medical Center, AMSTERDAM, Netherlands

⁴University Medical Center Utrecht, UTRECHT, Netherlands

⁵Deventer Hospital, DEVENTER, Netherlands

⁶Netherlands Cancer Institute, Netherlands

Background: While diseases like colorectal cancer were once seen as a single entity, they now appear to exist of multiple molecular subclasses. This has implications for treatment and hampers feasibility of prospective clinical trials, which require large sample sizes. With currently less than 10% of all cancer patients being enrolled in clinical trials, innovative alternatives are urgently required. Prospective observational cohort studies can provide standardized and validated collection of clinical data, tissue and blood samples and patient-reported outcome measures, and can serve as an infrastructure for registry based trials with improved recruitment.

The Prospective Dutch ColoRectal Cancer cohort (PLCRC) is a prospective multidisciplinary nationwide observational cohort study in the Netherlands (annual colorectal cancer incidence of 15,500 patients). The goal of the study is to facilitate basic, translational and clinical research in the field of colorectal cancer for national and international research groups.

Methods: All patients >18 years with histologically proven colorectal cancer are asked to participate. The informed consent includes consent for systematic collection of long-term clinical follow-up data. Optional consent is given for 1) filling out patient-reported outcome questionnaires; 2) standardized collection of tissue and blood samples; 3) being informed when clinically relevant DNA mutations are detected and 4) invitation for future interventional studies according to (amongst others) the cohort multiple randomized controlled trial design. This design allows patients to participate in multiple non-conflicting interventional clinical trials.

PLCRC is set up in close collaboration with other national data collection initiatives, including the Netherlands cancer registry (hosted by IKNL), the national pathology registry PALGA, the national biobanking infrastructure BBMRI-NL, and the Dutch Surgical Colorectal Audit (DSCA).

Results: Currently 11 centers are open for inclusion, more than 850 patients have been included, and a total of 10 studies are using the PLCRC infrastructure. In the second half of 2016, at least 10 more centers will open.

Of the included patients, 85-90% have consented to receive questionnaires, to be approached for future trials and to be informed about DNA mutations. More than 95% of patients have given consent for the collection of tissue and extra blood samples.

Conclusions: PLCRC is expected to provide long-term clinical data, tissue and blood samples, and patient-reported outcome measures of a large cohort of patients with colorectal cancer. PLCRC is well received by patients with the great majority giving consent for all options in the consent form. The available data and material will facilitate basic, translational and clinical research.

P08

Carcinoembryonic antigen as a predictor for pathologic complete response after neoadjuvant chemoradiation for rectal cancer

M.S. Cruz, D.M. Roda, J.P. Brandão, S.F. Gonçalves, G.A. Melo

Instituto Português de Oncologia de Coimbra Francisco Gentil, COIMBRA, Portugal

OBJECTIVES: Pathologic complete response (pCR) has been associated with improved local control, reduced distant disease and survival advantage in patients treated with neoadjuvant chemoradiation for advanced rectal cancer. Prognostic and predictive factors of pCR are not completely established. Carcinoembryonic Antigen (CEA) has been proposed as a biomarker for tumor response. The aim of this study was to evaluate the impact of pre-treatment CEA levels as a predictor of pCR after neoadjuvant chemoradiation for rectal cancer.

METHODS: This is a retrospective single-center study including patients diagnosed with stage II and III rectal adenocarcinoma. Those patients received neoadjuvant chemoradiation followed by surgical resection between 2004 and 2010. Patients were divided in two groups - with pathologic complete response and without pathologic complete response. Pre-treatment CEA levels were analysed and statistically correlated with pathologic response after chemoradiation using *Chi square* test, *Mann-Whitney U* and *Fisher's exact*.

RESULTS: A total of 101 patients were included in this study (62% male), with a median age of 62 [25-84] years old. 34 patients (33,6%) had stage II rectal cancer while 67 patients (66,3%) were classified as stage III. With a median *follow-up* of 63 months [6-126], pCR was achieved in 21 patients (20,8%). Despite the prognostic advantage of the pCR group, statistic values were only achieved regarding the 2 (P<0,001), 5 (P<0,001) and 10 years (P=0,001) Disease Free Survival (DFS) as well as 10 years Overall Survival (OS) (P=0,02). Pre-treatment CEA was significantly lower in the pCR group (5,06 vs. 14,36 ng/mL, P=0,005); 85% of the pCR group patients had normal CEA levels (≤ 5 ng/ml) versus 53% patients in the group without pCR (P=0,011). A CEA level ≤ 5 ng/ml was statistically associated with higher pCR rates (28,3% vs. 7,5%; *Odds ratio*= 4,876, 95 % CI= 1.3239 - 17.9580, P = 0.0172).

DISCUSSION/CONCLUSION: pCR after neoadjuvant chemoradiation for locally advanced rectal adenocarcinoma is associated with better prognostic results, specially regarding DFS and OS. As a predictive value, there is an association between lower/normal pre-treatment CEA levels (≤ 5 ng/ml) and pCR. Further studies should be carried out in order to clearly define predictive factors of tumour response. This knowledge can stratify patients who benefit from chemoradiation as a primary treatment and those who may need an adaptive approach.

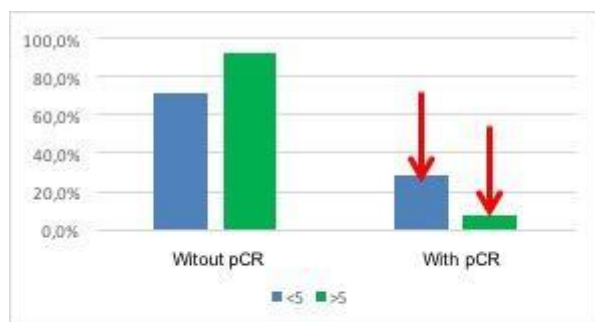

CEA	Without pCR		With pCR		Total
	n	%	n	%	
<5	43	71,7%	17	28,3%	60
>5	37	92,5%	3	7,5%	40

CEA levels and pCR rates

2-year oncologic outcome	pCR % (SE, n)	No-pCR % (SE, n)	p value
Overall survival	95.2 (4.9, 20)	93.8 (2.8, 75)	0.123
Disease-free survival	85.0 (8.2, 20)	67.9 (5.3, 78)	0.001
Local recurrence	0.0 (0.0, 4)	27.3 (7.9, 33)	0.827
Distant recurrence	75.0 (25.0, 4)	57.6 (8.7, 33)	0.070
5-year oncologic outcome	pCR % (SE, n)	No-pCR % (SE, n)	p value
Overall survival	81.0 (9.8, 17)	70.0 (6.2, 56)	0.248
Disease-free survival	80.0 (9.2, 20)	57.7 (5.6, 78)	<0.001
Local recurrence	25.0 (25.0, 4)	30.3 (8.1, 33)	0.603
Distant recurrence	75.0 (25.0, 4)	78.9 (7.2, 33)	0.681
10-year oncologic outcome	pCR % (SE, n)	No-pCR % (SE, n)	p value
Overall survival	76.2 (9.3, 21)	53.8 (5.6, 80)	0.002
Disease-free survival	80.0 (9.2, 20)	50.3 (5.7, 78)	<0.001
Local recurrence	-	-	-
Distant recurrence	-	-	-

2, 5 and 10 years oncological outcomes

P09

The DCCG Trials App: a mobile application with news and updated information on all ongoing trials of the Dutch Colorectal Cancer Group.

J. Huiskens, P.B. Olthof, J-M. Bakker, M.S. Galek-Aldridge, T.M. Van Gulik, M.G.H. Van Oijen, C.J.A. Punt

Academic Medical Center, AMSTERDAM, Netherlands

Introduction The field of medical trials is continuously expanding and trial designs, protocols and patient selection are becoming increasingly complex. We created a mobile application that provides easy to access and up to date information on ongoing clinical trials of the Dutch Colorectal Cancer Group (DCCG). Concise information is provided for each trial about the study design, criteria and logistics. You can find trials through a selection tree, trial-coordinator contact information is available and users receive trial-news messages. The application is freely downloadable for iOS and Android. The aim of this study is to investigate user statistics and satisfaction with the application.

Methods The application became available online on the 23 January 2015 on iOS and 28 January 2015 on Android platforms. We used Google analytics to monitor anonymous user data up to August 1st 2016. Moreover, a short online survey was conducted including items on: profession and age of the user, when the application is used, and satisfaction with the application.

Results A total of 5,600 unique users were identified worldwide that had a total of 12,983 sessions. In the Netherlands, 1496 (27%) unique users had a total of 8,360 (64%) sessions, with median session duration of 1:41 minutes (range 00:01-10:59). Trial information pages were visited 12,462 times for median 01:32 minutes (range 00:36-02:57) (Table). 117 people responded to our survey of which 64% (n=73) reported use of the application, and satisfaction was high (82%). Forty-seven percent (n=35) of all reported application users were medical doctors, 26% (n=19) nurse, 9% (n=7) researcher, 8% (n=6) datamanager and 9% (n=7) had another profession. The majority of users worked in either a teaching (41%) or academic hospital (33%), compared to a general hospital (16%). Most reported reasons of use were: urgent trial inquiry (57%) and use during multi-disciplinary meetings (47%) (Figure).

Conclusion The DCCG Trials App offers a fast and simple method to check all important information of all DCCG trials. The application is taken up well, and the majority users are satisfied, making it a useful tool for medical professionals treating patients with colorectal carcinoma in the Netherlands.

DCCG Trials	Page views (number)	Average time on page (min)
CAIRO5	2200	0:02:29
CHARISMA	1314	0:01:43
CAIRO4	1415	0:01:33
ASPIRIN	915	0:01:02
ORCHESTRA	1577	0:02:57
PLCRC	764	0:00:36
RAPIDO	953	0:01:32
SALTO	530	0:00:44
MRI2	397	0:00:43
COLOPEC	1167	0:02:29
FIT	571	0:00:39
TESAR	484	0:01:47
CONSTRUCT	175	0:00:51
	Total: 12462	Median: 0:01:32

Overview of all trial pages

When do you use the DCCG Trials App?

1	When I have a (urgent) question about a specific DCCG trial	41 / 57%
2	During multi-disciplinary meetings	34 / 47%
3	During my work at the outpatient clinic	21 / 29%
4	In preparation for the outpatient clinic	18 / 25%
5	In preparation for multi-disciplinary meetings	17 / 24%
6	When I finished work, mostly in the evening or at home	8 / 11%
7	Other	6 / 8%

Answers to the question: When do you use the DCCG trials App? (Multiple answers were possible)

P10

Evaluating the scientific basis of quality indicators in colorectal cancer care: results of a systematic review.
L. Keikes

Academic Medical Center, AMSTERDAM, Netherlands

Objectives. In colorectal cancer care, many indicators for assessment and improvement of quality of care are being used. However, the scientific basis of these indicators is often unclear. The aim of this systematic review is to assess reported quality indicators used in multidisciplinary colorectal cancer care during the last decade. *Methods.* We searched PubMed from 2005 to 2015 for original articles reporting about quality indicators in colorectal cancer care. Articles about colorectal cancer screening and comparative research of hospital performance were excluded. Included articles were divided into 3 categories: consensus-based, evidence-based, and validation cohort studies. Frequency tables were provided for each quality indicator, and analyzed for type of measurement (structure, process or outcome) and discipline(s) involved. *Results.* A total of 1163 studies were identified and after title, abstract and full-text screening, 41 articles were included: 12 (29%) articles were consensus-based, 7 (17%) evidence-based, and 22 (54%) validation cohort studies. In total, 389 quality indicators were reported: consensus-based (n=349), evidence-based (n=7), and validation (n=33), respectively. Of all reported indicators, 45% concerned surgical items. The vast majority were process indicators (n=315; 81%) and the remaining outcome (n=57; 15%) or structure measurements (n=17; 4%). The most frequently reported consensus-based indicators (in ≥7 of 12 articles) were: preoperative or postoperative colonoscopy, radiotherapy for rectal cancer, preoperative imaging, referral to medical oncologist if indicated and adjuvant chemotherapy for stage III colon cancer. Only 1 indicator was reported in all 3 categories: minimum of examined lymph nodes. *Conclusions.* There is an abundance of colorectal cancer quality indicators, of which the majority are surgical, consensus-based process measures which have not been validated in cohort studies. In order to facilitate the implementation of indicator-based assessment and improvement of colorectal cancer care, we propose to define a limited evidence-based dataset of validated quality indicators, with a focus on outcome indicators.

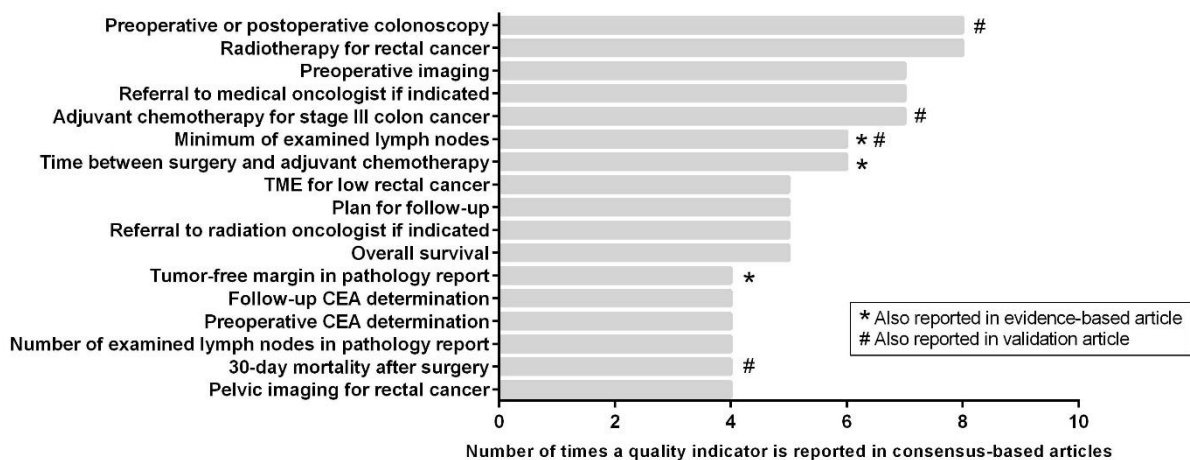

Overview of reported consensus-based quality indicators (at least 4 times) with corresponding evidence-based and validation cohort studies

P11

Improving quality of care of colorectal cancer by discussing variation of care at a regional level in the Netherlands

M.A. Elferink¹, A.C. Bos¹, G.R. Vink¹, V.E.P.P. Lemmens²

¹Netherlands Comprehensive Cancer Organisation, UTRECHT, Netherlands

²Comprehensive Cancer Center (IKNL), EINDHOVEN, Netherlands

Background

In the Netherlands, colorectal cancer patients are treated in every hospital in the country. The incidence and treatment of colorectal cancer, and all other malignancies, are registered in the nationwide population-based Netherlands Cancer Registry (NCR) by the Netherlands Comprehensive Cancer Organisation (IKNL). IKNL collaborates with healthcare professionals and patients on the continuous improvement of oncological and palliative care. Data from the NCR are amongst others used for regional reports to compare treatment patterns and outcomes of all hospitals in a region.

Objectives

To analyse variation in colorectal cancer care between hospitals in a region in the Netherlands with data from the NCR, facilitating the discussion about quality of care, and revealing best practices.

Methods

All patients diagnosed with colorectal cancer in 2014 in the Netherlands were selected from the NCR (N=14096). Hospitals in the Netherlands treating colorectal cancer patients were included (N=90) and divided in regions based on collaboration of individual hospitals and their agreements about referral of patients (N=8). Variation in treatment according to guidelines, referral patterns and patient outcomes between individual hospitals were observed and presented at a regional level. Expected proportions of patient outcomes were calculated using multivariable logistic regression. Results were shown per individual hospital with the regional and nationwide mean as benchmark. Results were discussed in regional multidisciplinary working groups of health care professionals. Data were preferably shown non-anonymously after approval of all hospitals.

Results

Results were presented in all regions, mostly non-anonymously. There were no differences in age and stage distribution between hospitals. Variation in several aspects of colorectal cancer care was found, among others the administration of adjuvant chemotherapy in patients with stage III colon cancer and the 90-days postoperative mortality. With regard to the administration of adjuvant chemotherapy, there were differences between hospitals in patients of 70 years and older at diagnosis, but not in patients younger than 70 years. The nationwide mean of adjuvant chemotherapy in older patients was 39%, but this proportion varies from 20% to 65% between hospitals. The expected proportion of 90-days postoperative mortality of both colon and rectal cancer did not vary between hospitals. However, the observed proportion of 90-days postoperative mortality for colon cancer was nationwide 3.5% and ranges between hospitals from 1% to 9%; for rectal cancer the nationwide mean was 2.4% and varies between hospitals from 0% to 6%. Discussion of the results in a group of health care professionals have, for example, led to a regional agreement of standardizing MRI reports. Furthermore, following these regional results, one region will discuss 10 test cases of patients with colorectal cancer in the multidisciplinary meetings of all hospitals to determine the variation in treatment policy between the hospitals.

Discussion/conclusion

Regional reports give insight in differences in treatment and outcome between hospitals. Data on colorectal cancer care at hospital level can be used to review and optimize the quality of care. The results can facilitate the discussion about variation in outcomes, reveal best practices and support the development of comprehensive cancer networks.

P12

Cardiovascular disease (CVD) prevention in colorectal cancer survivors

L. Gutiérrez¹, J. Ramos¹, B. Núñez¹, R. Gómez¹, J. Ros¹, J.L. Sanchez², L. Brea³, I. Pagola³, A. Ruiz-Casado¹

¹HU Puerta de Hierro Majadahonda, MAJADAHONDA, MADRID, Spain

²Hospital Universitario de Getafe, GETAFE, Spain

³Universidad Europea de Madrid, VILLAVICIOSA, MADRID, Spain

CVD prevention is a coordinated set of actions aimed at eliminating or minimizing the impact of CVD and their related disabilities. Many risk factors, particularly obesity and diabetes mellitus have increased substantially. The 6th Joint Task Force Guidelines recommend a systematic CV risk assessment in adult men older than 40 and women older than 50 years of age. CVD and colorectal cancer (CRC) share some risk factors such as age, sedentarism, smoking, diet, diabetes and obesity. The high rate of curative, increased survival and toxicity of cancer therapies make up CVD a health problem for CRC survivors.

The American Heart Association defines "ideal cardiovascular health" as the simultaneous presence of 4 health factors (Abstinence from smoking within the last year, untreated total cholesterol < 200 mg/dl, untreated blood pressure <120/<80 and absence of diabetes mellitus), 4 health behaviours (Abstinence from smoking within the last year, BMI < 25 kg/m², Moderate and vigorous physical activity (MVPA) ≥ 150 min/wk, Healthy diet) and absence of clinical CVD. The prevalence of ideal cardiovascular health in US is approximately 5%. Whereas factors not always can be modified, health behaviours are modifiable and are an important target for cancer survivors surveillance.

OBJECTIVE: To identify the prevalence of CVD and the prevalence of ideal cardiovascular health at the time of diagnosis of CRC.

MATERIAL AND METHODS: Antecedents, physical signs and laboratory data were abstracted from the clinical record. PA was objectively measured through accelerometers. Adherence to diet was evaluated through PREDIMED questionnaire.

RESULTS: 52 patients were recruited between March 2015 and June 2016. Mean age was 66 (43-81). 26 patients had localized disease and 26 patients had metastatic disease. 24% had CVD (cardiac failure, cardio or cerebrovascular disease). Only 1 patient met the complete definition of ideal CV health.

Table 1

CONCLUSIONS: The prevalence of ideal cardiovascular health in a Spanish population of CRC survivors is about 2%. This population was overall compliant with PA recommendations and adhered to a healthy diet. The interventions should be aimed at reducing BMI. Interventions exploring more ambitious programs with vigorous physical activity in CRC survivors are warranted.

52 patients (M:35; F:17) mean age 66			
Health behaviors		Health factors	
No smoker 83%			
Adherence to healthy diet	67%	Hypertension	53%
BMI <25	35%	Diabetes	19%
Weekly moderate and vigorous PA	430,83 min/sem	Hypercholesterolemia	44%

P13

Identification of Targeted Therapy Candidates for Metastatic Colorectal Cancer: A Combination of Systems Biology and Structural Biology Approach

M. Poorebrahim¹, M. Iman², S.S. Mostafavi³, S.S. Arab⁴, S. Azimzadeh², M. Vahedalein⁵

¹Tehran University of Medical Sciences, TEHRAN, Iran

²Baqiyatallah University of Medical Sciences, TEHRAN, Iran

³Islamic Azad University, TEHRAN, Iran

⁴Tarbiat Modares University, TEHRAN, Iran

⁵Khayyam Institute of Higher Education, Mashhad, Iran

Background: Recent studies have shown that the high mortality of patients with colorectal cancer (CRC) is related to its ability to spread the surrounding tissues and invade to distant sites. In this study, we proposed a combinational therapy, an inhibitory peptide in combination with miRNA targeting, for metastatic CRC based on the analysis of gene expression profile of metastatic CRC samples compared to CRC samples.

Methods: After data analysis with GEO2R and gene annotation using DAVID server, regulatory interactions of differentially expressed genes (DEGs) were obtained from STRING, GeneMANIA, KEGG and TRED web tools and resulted network was visualized by Cytoscape software. Clustering analyses of this network were performed using Cytoscape plug-ins.

Results: We found that the HOXB family is the most important functional complex which may has a crucial role in CRC invasion. Accordingly, we designed an anti-HOXB7 peptide based on the binding interface of its co-activator, PBX1. Several steps including predicting, evaluating and refining of 3D structure of HOXB7 were performed by means of in silico technology. In parallel, the corresponding validated microRNAs (miRNAs) were obtained from mirDIP web server and a miRNA-Gene regulatory network was also reconstructed. Topological analysis of this network indicated that hsa-miR-222 is one of the most important oncomirs involved in the regulation of obtained DEGs. Thus, this miRNA along with anti-HOXB7 peptide were considered as potential targets for metastatic CRC. Molecular docking studies showed that the designed peptide can bind to desired binding pocket of HOXB7 with a high binding affinity. Further confirmations were also obtained by Molecular dynamics (MD) simulations carried out by GROMACS package.

Conclusion: In conclusion, our findings suggest that simultaneous targeting of key regulatory genes and miRNAs may be a useful strategy for prevention of CRC metastasis. The effects of designed inhibitors on the metastatic CRC will evaluate using metastatic cell line SW620.

P14

Study on in vitro anti-tumor activity of green tea extract on the human colon carcinoma cell line (Caco-2) as a model for Colorectal Cancer

F. Bokharaei-Salim, M. Esghaei

Department of Virology, Iran University of Medical Sciences,, TEHRAN, Iran

Objectives: The present study was designed to investigate whether green tea (*Camellia sinensis*) leaves extract might inhibit growth and propagation of **Caco-2** cells.

Methods: We studied the in vitro **inhibitory activity** of *Camellia sinensis* extract. MTT assay was used to investigate the inhibitory effect of different concentrations of the extracts on the human colon carcinoma cell line (Caco-2) and the IC50 values were calculated.

Results: The *Camellia sinensis* extract had different degrees of inhibitory effects on these two cells, and when exposure time was 48 h, the inhibition rate reached its peak, with IC50 values of 13.98 µg/mL .

Conclusion: The *Camellia sinensis* extract had a good inhibitory effect on human Caco-2 cell line and thus has certain development prospects.

Keywords: *Camellia sinensis*.; MTT; anti-tumor; cell culture

P15

Inhibitory Activity of *Camellia sinensis* extract on the HT-29: Human Colorectal Adenocarcinoma Cell Line

M. Esghaei, F. Bokharaei-Salim

Department of Virology, Iran University of Medical Sciences,, TEHRAN, Iran

Abstract

Objectives: Our study has adopted a bioassay-guided approach to optimize the extraction of *Camellia sinensis* (Green Tea) for anti- Colorectal Cancer bioactive components. The tumor growth inhibitory activity of the extract on HT-29line was evaluated in vitro.

Methods: *Camellia sinensis* extract was prepared using different methods. MTT and tritiated thymidine incorporation assays were used to evaluate the in vitro anti-tumor effects.

Results: The in vitro anti-tumor effects indicated that the inhibition rate gradually increases with the increase of extract concentration and the extension of time, with IC50 169.33, 89.49, and 42.77 µg/ml at 24 h, 48 h, and 96 h respectively .In this study, the in vitro MTT assay was used to determine the inhibitory effect of propagation of Human Colorectal Adenocarcinoma Cell Line.

Conclusion: The method of this study is simple and practical and thus found out that the extract of green tea has inhibitory effect on HT-29 cells. The effect can be attributed, at least in part, to the induction of apoptosis.

Keywords: *Camellia sinensis*; MTT; HT-29 cell line

P16

Modulation of Platelet levels by an Anti-IL-1α Antibody (MABp1) in Advanced Colorectal Cancer Patients

S. Shivaswamy¹, T. Hickish², P. Mohanty¹, M. Stecher¹, K. Sunley¹, A. Varshney¹, R. Martin¹, J. Simard¹

¹XBiotech, AUSTIN, USA

²Royal Bournemouth Hospital NHS Foundation Trust, BOURNEMOUTH, United Kingdom

Background: In a Phase III study, treatment with MABp1, an anti-IL-1α antibody, has demonstrated 76% relative increase in clinical response rate versus placebo in end-stage colorectal cancer patients. In addition to the primary end point (improved health status as measured by lean body mass and pain, fatigue and appetite), secondary measures included monitoring of pharmacodynamic parameters such as serum IL-6 levels and platelet counts. With respect to these secondary endpoints, patient receiving MABp1 treatment showed decreased serum IL6 levels as well as platelet counts. IL-1α is known to upregulate IL-6, while that latter is a known inducer of megakaryocytopoiesis. The reduction in IL-6 and platelet counts in patients treated with IL-1α suggests that that platelet-derived IL-1α may be both a target on antibody therapy and play an important role in regulation of megakaryocytopoiesis. While the role of platelet-derived IL-1α has been established in animal models for vascular endothelial cell activation and the pathogenesis of cerebrovascular inflammation, few studies elucidated the role or even confirmed the expression of IL-1α on human platelets. Here we present findings to confirm the expression of platelet IL-1α on resting and activated platelets within a healthy human population.

Methods: Platelets from fresh human blood were isolated using discontinuous iodixanol density gradient method. The purified platelets were stained with MABp1 or isotype control before and after activation with thrombin and lipopolysaccharide, and observed by confocal microscopy and flow cytometry. In addition, the isolated platelets were lysed and the membranes were isolated by ultracentrifugation. The IL-1α on the membrane was immunoprecipitated using a monoclonal pro-IL-1α antibody. The membrane proteins were resolved on an SDS-PAGE and human IL-1α was detected using various monoclonal as well as polyclonal antibodies. The immunoprecipitated protein was digested with trypsin, and the isolated peptides were subjected to peptide mass fingerprinting.

Results: Work done by our group has confirmed the presence of IL-1a on the surface of platelets. Confocal microscopy and Flow Cytometry has shown an activation dependent increase in membrane IL-1a levels. Western blotting and immunoprecipitation confirmed that the IL-1a is present as in integral membrane in its propeptide form rather than by a protein-protein interaction. In addition, our study also showed that the propeptide is sensitive to cleavage into its mature form by calpain-like protease also present on the surface of platelets. Peptide Mass Fingerprinting of the immunoprecipitant using a QToF Micro Mass Spectrometer identified five unique peptides specific to human IL-1a at high confidence levels.

Conclusions: Based on our findings and results from previous studies, platelets appear to play an important role in the development of important conditions, including cancer. We confirm that IL-1a is present on human platelets and that this may represent an important factor in regulating platelet thrombocytosis and consequent pathology in cancer.

P17

Harnessing Natural Human Immunity to Create Breakthrough Anti-Cancer Therapies

S. Shivaswamy¹, T. Hickish², P. Mohanty¹, M. Stecher¹, J. Simard¹

¹XBiotech, AUSTIN, USA

²Royal Bournemouth Hospital NHS Foundation Trust, BOURNEMOUTH, United Kingdom

Background:

The crucial role for humoral immunity in protection against infectious disease has been known for some time. Less understood is the immunoregulatory role antibodies play in neutralizing endogenous mediators of inflammation, and the importance of these responses in protecting the body against non-infectious disease.

Clinical findings from multiple studies—from dermatology to oncology—with a true human antibody targeting interleukin-1 alpha confirms that these antibodies can play a critical role in downregulating pathological inflammation. True Human antibodies are selected from individuals with natural immunity against either a pathogen or self-antigen. Antibody sequences are derived from unmodified heavy and light chain human B lymphocyte sequences that have undergone ontogeny and selection inside a human body. In addition to being a largely untapped resource for human therapeutics, antibodies derived from a human immune response can be expected to exhibit high affinity, ideal safety and pharmacokinetics.

Methods:

We have screened thousands of healthy human donors using a Super High Stringency Antibody Mining Approach. Using this technology, we have examined donors for antibodies against multiple endogenous inflammatory mediators and pathogens. A production system for rapidly transitioning from small scale screening of these antibodies to kilogram yields has been developed in-house using disposable technologies.

Results:

Monoclonal antibodies derived from natural immunity have now been used in multiple clinical trials. Sequence analysis has shown somatic hypermutations not only in the CDRs but also within the framework regions are the result of active selection processes against the targets, including endogenous antigens. To date, the safety of these antibodies is unprecedented. Results with the anti-IL-1a antibody MABp1 have for the first time shown that humoral immunity is active in producing antibodies capable of controlling non-infectious disease processes, including cancer.

Conclusions:

Harnessing natural humoral immunity is giving us new insights into the pathophysiology of disease and is offering breakthrough approaches to treatment. These products may allow us to treat disease. Combined, our discovery and production technologies allow for the relatively rapid development of a wide array of next generation therapeutics with safety and tolerability like never before.

P18

Expression of vitamin D receptor and vitamin D-associated gene signature in tumour stromal fibroblasts predicts clinical outcome in colorectal cancer patients

G. Ferrer-Mayorga¹, G. Gómez-López², R. Cantero³, F. Rojo⁴, A. Muñoz¹, M.J. Larriba¹

¹Instituto de Investigaciones Biomédicas „Alberto Sols,, MADRID, Spain

²Centro Nacional de Investigaciones Oncológicas, MADRID, Spain

³Hospital Universitario La Paz, MADRID, Spain

⁴Hospital Universitario Fundación Jimenéz Díaz, MADRID, Spain

Objective. Colorectal cancer (CRC) is the neoplasia most strongly associated with vitamin D deficiency. Many epidemiological studies indicate that vitamin D deficiency increases the risk of CRC and thus, suggest that vitamin D has a protective effect on CRC. This is supported by preclinical studies using vitamin D, 1,25-dihydroxyvitamin D₃ (1,25(OH)₂D₃, the most active vitamin D metabolite) or analogues in cultured cells and experimental animals. 1,25(OH)₂D₃ inhibits the proliferation and promotes the differentiation of colon carcinoma cells by mechanisms that include cell cycle arrest at G₀/G₁, the blockade of the Wnt/β-catenin pathway and the induction of E-cadherin and other epithelial adhesion proteins. 1,25(OH)₂D₃ action is mediated by the vitamin D receptor (VDR), a member of the superfamily of nuclear receptors that upon ligand binding regulates the transcription rate of hundreds of genes. Consequently, VDR expression is the main determinant of cell responsiveness to 1,25(OH)₂D₃. Fibroblasts are the

main cellular component of tumour stroma and upon activation by the tumour microenvironment they contribute to tumorigenesis by several mechanisms. In this study we explored VDR expression and $1,25(\text{OH})_2\text{D}_3$ action on CRC stromal fibroblasts.

Methods. The expression of VDR and of two $1,25(\text{OH})_2\text{D}_3$ target genes was analysed in 658 metastatic CRC patients with prolonged clinical follow-up. Primary cultures of patient-derived colon normal fibroblasts (NFs) and cancer-associated fibroblasts (CAFs) were set up to study $1,25(\text{OH})_2\text{D}_3$ effects on gene expression and on two fibroblast protumoural properties: collagen gel contraction and induction of carcinoma cell migration. Publically available datasets were used to correlate the expression of the gene signature imposed by $1,25(\text{OH})_2\text{D}_3$ in CAFs with CRC patient clinical outcome.

Results. High VDR expression in tumour stromal fibroblasts is associated with better overall survival and progression-free survival in CRC. Patient-derived NFs and CAFs express VDR and respond to $1,25(\text{OH})_2\text{D}_3$. $1,25(\text{OH})_2\text{D}_3$ inhibits the ability to reorganize collagen fibres and contract collagen gels of NF and CAF primary cultures. In addition, $1,25(\text{OH})_2\text{D}_3$ reduces the capacity of NF and CAF cultures to paracrinally promote the migration of human colon carcinoma cells in Transwell-mediated coculture assays. Remarkably, global transcriptomic analyses show that $1,25(\text{OH})_2\text{D}_3$ imposes in CAFs a gene signature that correlates with longer overall survival and disease-free survival of CRC patients. Moreover, expression of two $1,25(\text{OH})_2\text{D}_3$ target genes *CD82* (upregulated) and *S100A4* (downregulated) is associated directly and inversely, respectively, with stromal VDR expression and CRC patient clinical outcome.

Conclusions. Our results indicate that CRC stromal fibroblasts express VDR and that their gene expression and physiology is modulated by $1,25(\text{OH})_2\text{D}_3$ in a way that may contribute to the antitumoural action of $1,25(\text{OH})_2\text{D}_3$ against this neoplasia. High expression of VDR and of the $1,25(\text{OH})_2\text{D}_3$ -associated gene signature in stromal fibroblasts predicts a favourable clinical outcome in CRC. Thus, treatment of CRC patients with VDR agonists could be explored even in the absence of VDR expression in carcinoma cells.

P19

Detection of structural variants in colorectal adenoma-to-carcinoma progression reveals a novel class of genes that are recurrently and commonly affected by chromosomal breaks

R.J.A. Fijneman¹, E. Van den Broek², M.J.J. Dijkstra³, Q.J.M. Voorham², B. Carvalho¹, M.A. Van de Wiel², S. Abeln⁴, G.A. Meijer¹

¹Netherlands Cancer Institute, AMSTERDAM, Netherlands

²VU University Medical Center, AMSTERDAM, Netherlands

³VU University, AMSTERDAM, Netherlands

⁴VU university medical center, AMSTERDAM, Netherlands

Objectives: The transition of pre-malignant colorectal adenomas into malignant colorectal carcinomas (CRCs) is accompanied by accumulation of somatic genetic alterations. The contribution of small nucleotide variants (SNVs) such as gene point mutations in *KRAS*, and numerical DNA copy number aberrations (CNAs) such as gains of large segments of chromosome 20q, in tumor genomes has been studied extensively. In contrast, studies that systematically detect recurrent structural variants (SVs) such as chromosomal breaks across large series of clinically well-defined samples, are scarce. We recently developed 'GeneBreak', a computational method to identify genes that are recurrently affected by the genomic location of CNA-associated chromosomal breaks, and demonstrated high prevalence and clinical relevance of recurrent breakpoint genes in advanced CRCs (PLoS One 2015;10(9):e0138141). Using a similar approach, the present study aimed to determine what recurrent breakpoint genes contribute to colorectal adenoma-to-carcinoma progression.

Methods: Differences in somatic CNA-associated gene breakpoint frequencies in 466 CRC and 118 colorectal adenoma samples were examined using high-resolution array-comparative genomic hybridization (aCGH) profiles. Pearson's Chi-square statistic was applied to determine differences in gene breakpoint frequencies between CRC and adenoma samples.

Results: In total 21 recurrent breakpoint genes were more frequently affected in CRCs compared to adenomas ($p < 0.05$). *MACROD2* was affected by chromosomal breakpoints in 40% of CRCs while not being affected in colorectal adenomas. The frequencies of SVs in the other 20 recurrent breakpoint genes ranged from 5% to 29% in CRCs, and from 0% to 2% in colorectal adenomas.

Discussion / Conclusion: We identified 21 recurrent breakpoint genes that are frequently affected by SVs in CRCs but not in colorectal adenomas. Additional studies are needed to further elaborate the biological and clinical role of these 21 candidate driver genes for colorectal tumor progression.

P21

Prevalence and cognitive Factors of Fecal Occult Blood Test

F. Jalilian

Kermanshah University of Medical Sciences, Kermanshah, Iran., KERMANSHAH, Iran

Objectives: Nowadays, cancer is one of the most important causes of morbidity and mortality in all countries. The aim of this study was determine the prevalence and factors influencing undergoing fecal occult blood test (FOBT) based on health belief model.

Methods: A cross-sectional study was conducted among 500 people who over the 50 years old in Iran, during 2016 which was randomly selected for participation in this study. Participants filled out a self-administered questionnaire including the health belief model components. Data were analyzed by SPSS version 21 using bivariate correlations and logistic regression statistical tests at 95% significant level.

Results: The mean age of respondents was 58.32 years [95% CI: 57.7, 58.9], ranged from 50 to 73 years. About, 11.2% of the participants had a history of undergoing FOBT. The best predictors for undergoing FOBT was perceived benefit with odds ratio estimate of 8.456, and perceived self-efficacy with odds ratio estimate of 6.915.

Discussion / Conclusion: It seems that perceived benefit and perceived self-efficacy were the best predictors of undergoing FOBT behavior.

Keywords: Undergoing FOBT, Perceived Benefit, Perceived Self-efficacy.

P22

Social determinants effective in colorectal cancer screening

B. Karami-Matin

Kermanshah University of Medical Sciences, Kermanshah, Iran., KERMANSHAH, Iran

Objectives: Colorectal cancer is the third most common type of non-skin cancer in both men (after prostate cancer and lung cancer) and women (after breast cancer and lung cancer). It is the second leading cause of cancer death in the United States after lung cancer. The aim of this study was to determine the knowledge on colorectal cancer and the related background factors in the urban population aged over 50 years in the western of Iran.

Methods: This study was of descriptive cross-sectional type which was conducted among 500 individuals aged over 50 years in Iran was randomly selected to participate voluntarily in the study. Data collected by questioner and were analyzed by SPSS version 21 using independent t-test, ANOVA and correlation statistical tests at 95% significant level.

Results: The mean age of respondents was 58.32 years [95% CI: 57.7, 58.9], ranged from 50 to 73 years. Only 4.7 percent of the participants knew what colorectal cancer was and what its screening methods were. The mean score of knowledge construct about colorectal cancer among the participants was 5.72 with standard deviation of ± 2.57 . Furthermore, knowledge of cervical cancer was significant association with sex, educational level and positive family history of colorectal cancer. In addition, knowledge about colorectal cancer was significantly related to the age ($r = -0.095$ & $P = 0.040$).

Discussion / Conclusion: It seems that designing and implementation of interventional programs based on our findings to improve knowledge about colorectal cancer among target population is helpful.

Keywords: Colorectal Cancer, Knowledge, Socio-Demographic Factors.

P23

Socio-Cognitive Determinants of Fecal Occult Blood Test in Colorectal Cancer Screening

M. Mirzaei-Alavijeh

Kermanshah University of Medical Sciences, Kermanshah, Iran., KERMANSHAH, Iran

Objectives: Annually, five thousand persons are diagnosed with colorectal cancer in Iran; annual fecal occult blood test (FOBT) is one of the common methods of colorectal cancer screening. The aim of this study was to determine the factors related to undergoing FOBT based on the theory of planned behavior.

Methods: This cross-sectional study conducted in the west of Iran, and among the total of 500 people who over the 50 years old, were randomly selected to participate voluntarily, during the 2016. Participants filled out a questionnaire and data were collected based on the interview. Data were analyzed by SPSS version 21 using the bivariate correlations, linear and logistic regression statistical tests.

Results: The three predictor variables of 1) attitude, 2) subjective norms, and 3) perceived behavioral control accounted for 35% of the variation in the outcome measure of the intention to undergoing FOBT. The best predictor for undergoing FOBT was attitude [Beta: 0.350, t: 9.077, p: <0.001].

Discussion / Conclusion: It seems that attitude toward FOBT behavior was the best predictor for doing FOBT and it suggest in using of this result for FOBT behavior promoting.

Keywords: Health Promotion, Attitude, Self-efficacy.

P24

Stool DNA methylation marker suitable for screening for colorectal cancer.

K. Rønild¹, T.Ø Østergaard Nielsen¹, M.M.A. Jørgensen¹, H.B. Rahr¹, J. Lindebjerg²

¹Vejle Hospital, VEJLE, Denmark

²Danish Colorectal Cancer Center South - Center of Clinical Excellence, VEJLE, Denmark

Objectives: Colorectal cancer (CRC) is the third most commonly diagnosed malignancy in the world. Research has shown that population screening for CRC can reduce mortality by 15 - 33%. The method often used for population based screening for CRC has been based on the findings of faecal occult blood. The sensitivity of this test is, however, only 50-60% when used as a single examination. Tumour specific DNA methylation in stool is a new method for detecting colorectal cancer and precancerous lesions at an early stage. We wanted to define suitable markers for a DNA methylation based screening assay in order to develop a more sensitive screening tool for early diagnosis of CRC.

Methods: We used the Illumina Infinium 450K Methylation assay. Using this platform we analyzed tissue samples collected at Vejle Hospital, Denmark. Eight normal mucosa samples and nine tubulovillous or villous adenomas from the same eight patients were analyzed. We also analyzed eight samples from patients with early colorectal cancer (T2-3NOV0), eight samples from patients with advanced colorectal cancer (T3N1-2V0-1) and 10 normal mucosa samples from participants with a normal colon.

We then conducted various filtering analysis to define aberrant methylated candidate CpG sites suitable for a stool based screening test. The CpG site was validated for difference in methylation level between normal and differentiated mucosa by a CpG specific Methylation Sensitive High Resolution Melting (MS-HRM) analysis on tissue samples analysed with the Illumina array platform. We also had matched stool samples from 7 of 8 patients with adenomas, 3 of 8 patients with early colorectal cancer and 8 of 8 patients with advanced colorectal cancer. Thus, we investigated 18 stool samples from patients where we have matching tissue samples - either polyps, early stages or advanced colorectal cancer.

Results: We identified candidate CpG sites showing a great difference in methylation level between normal and differentiated mucosa. One promising candidate site was in the CpG island of the OPLAH gene. The results of the melting point analyses on tissue samples were consistent with what was found with the methylation-specific array. It was possible to detect methylation of the specific OPLAH site in 15 out of 18 tested stool samples. It should be stressed that methylation was detected in stool samples from persons with very small adenomas (4-6 mm of size).

Conclusions: We find OPLAH to be a promising novel and sensitive biomarkers with the potential to detect pre-cancerous polyps and cancerous lesions in colon mucosa with improved sensitivity in non-invasive stool diagnostic analysis. This biomarker could be particularly suitable for the detection of early stages of colorectal cancer. We are now conducting an exploratory study on 200 patients with positive iFOBT from the CRC screening population.

P25

Prediction and prevention of liver failure after major liver resections for liver metastases of colorectal cancer: the role of functional tests.

L.O. Petrov¹, D.V. Sidorov¹, N. Rubtsova¹, A. Leontiev², M.V. Lozhkin¹, A. Isaeva³

¹P. Hertsen Moscow Oncology Research Institute, MOSCOW, Russia

²? HERTSEN MOSCOW ONCOLOGY RESEARCH INSTITUTE, MOSCOW, Russia

³Hertsen Moscow Oncology Research Institute, MOSCOW, Russia

Objective: Hepatic resection is the most important component of treatment of CRLM. The concept of remnant liver volume (RLV) has been introduced and can be assessed with CT. However, lack of correlation between morphologic hypertrophy and functional recovery fuelled the enthusiasm for functional imaging. The aim of the study is to improve the treatment results of patients with colorectal metastatic cancer of liver (CRLM) by reducing the risk of post-resection liver failure based on the assessment of liver functional reserve.

Materials and methods. The study included 2 independent branches of patients underwent surgery for liver metastases in the department of abdominal oncology at the P.A. Herzen Moscow Oncological Research Institute. Group I included 47 patients: in addition to the standard treatment algorithm they underwent 13C methacetin breath test and dynamic scintigraphy of liver in the preoperative stage.

Patients from the group II (n = 30) underwent standard clinical and laboratory examination, without preoperative evaluation of liver functional reserves; the level of total bilirubin, albumin and prothrombin time showed no decrease in liver function. Post-resection liver failure was established based on 50/50 criterion when evaluated on the 5th postoperative day.

According to results of preoperative liver function tests decision of changing surgical technique were made.

Results. The analysis of operational characteristics of functional tests showed absolute sensitivity of 13C methacetin breath test (SE ≥ 100 %) and negative predictive value (-VP ≥ 100 %) in case of integrated application of 2 diagnostic methods. A strong positive correlation (r 0.75) was found between preoperative liver function reserve (LFR) determined with HBS and 13C-methacetin breath test results in patients with metastatic liver tumors.

Comparison of the results by Bland-Altman showed no systematic differences, the average difference between measurements was -0.01. In conformity with functional tests results SVI-SVII bisegmentectomy was performed instead of right hepatic resection in 15 cases (31,2%). In 6 patients (12,7%) surgical approach was revised for two-

stage liver resection.

An incidence of post-resection acute liver failure by 50-50 criteria in the study group was significantly 2.2-fold lower than in the control group – 10.6 % and 23.3 %, respectively ($p < 0.001$). “◆

Conclusion. Combination of preoperative dynamic scintigraphy of liver with 13C methacetin breath test allows to perform comprehensive assessment of liver functional reserves, and it can greatly improve postoperative results of anatomic resections in patients with liver metastases due to decreasing of incidence of postoperative liver failure.

Key words: liver resection, post-resection liver failure, functional tests, CRLM

P27

Preservation of anal sphincter and colostomy rate in locally advanced rectal cancer. Experience of multi-agency group 2010-2016

B. Losada Vila¹, M.V. De Torres², I. Juez², D. Gutierrez Abad¹, J.C. Camara³

¹Hospital Universitario de Fuenlabrada, MADRID, Spain

²H Universitario Fuenlabrada, MADRID, Spain

³H Universitario Alcorcon, MADRID, Spain

Objectives:

To review types of surgery that have been made after neoadjuvant chemoradiotherapy depending on the distance to the anal margin.

Methods:

We studied retrospectively 150 patients (p) diagnosed with locally advanced rectal cancer at our institution between 2010-2016. All of them received three-dimensional RDT with a dose of 50.4 Gy with concomitant chemotherapy (5FU). Surgery has performed after 8 weeks of treatment in 147 of them. The results have been grouped taking into account the distance from the anal margin following the diagnostic tests employed for analysis.

Results:

Mean age was 67 years. 147 patients have been operated (R0 in 96.3%): abdominoperineal resection in 104 (70.7%), abdomino-sacral amputation 43 (29.3%). The distance from the anal margin was measured by MRI in 96% of cases. 32 p (21.3%) were located between 1-4cm (group 1), 50p (33.3%) between 5-7 cm (group 2), 52 p (34.7%) between 8-10cm (group 3) and 12 p (8%) > 10 cm (group 4) Abdomino-sacral amputation is chosen in those tumors closer to the anal margin (<4 cm), although in our group we have 7 patients (18.7 %) with abdominoperineal resection. As we ward off from anal margin, abdominoperineal resection rates increase and abdomino-sacral amputation are uncommon (8 % in > 10 cm and 5 % in 7-10 cm).

Colostomy was definitive in 10/52 (19.2%) of group 3 and 2/12 (16.6%) in group 4, whereas protection colostomy was up to 20/50 (40%) in group 2 and 22/52 (42.3%) in group 3. Some protective colostomy group were final at the request of patient.

All patients in the group with RAB disease <4 cm, have ultralow resection syndrome occurring as fecal incontinence and impact on quality of life. 2 distant relapses have occurred at 8 and 9 months from radiation therapy, with no local relapse.

Conclusions:

Abdominoperineal resection is widely used in all our patients, with ultralow resection syndrome in those with <4 cm from anal margin. Colostomy rate protection is nearly 50%, being able to “rebuild” in almost 100%. The unreconstructed ones have been at the request of the patient.

P28

Reporting of patient characteristics and stratification factors in phase III trials investigating first-line systemic treatment of metastatic colorectal cancer: a systematic review

K.K.H. Goey, M. Koopman

University Medical Center Utrecht, UTRECHT, Netherlands

Objectives: Patient characteristics and stratification factors are pivotal for the outcome of randomized trials (RCTs). Uniform reporting on these parameters would greatly facilitate cross-study comparisons and extrapolation of trial results to clinical practice. In 2007, standardization on patient characteristics reporting and stratification factors in metastatic colorectal cancer (mCRC) trials was proposed¹. We investigated the use of this proposal in first-line mCRC trials published between 2009 and 2016.

Methods: We searched PubMed and Embase (Jan 2009 – June 2016) for phase III RCTs on first-line systemic therapy of mCRC. Reporting of patient characteristics and use of stratification factors were extracted and analyzed for adherence to the proposal made in 2007.

Results: Forty-three RCTs were identified (total: 23,161 patients), reporting a median of 10 (range: 6-18) patient characteristics and 4 (range: 1–9) strata per study. In total, 44 different patient characteristics and 25 strata were reported. Age, gender, performance status, primary tumor site and prior adjuvant chemotherapy were most frequently reported as patient characteristics (88-100%). Laboratory values alkaline phosphatase, lactate dehydrogenase and white blood cell count were infrequently reported (12-26%)(Fig 1). Performance status,

treatment center and prior adjuvant chemotherapy were the most commonly used strata (>50%)(Fig 2). A median of 8/12 (range: 4-11) of the proposed patient characteristics was reported. We observed a slight improvement in the reporting of the proposed parameters in studies from 2009-2016 compared with studies from 2001-2005 included in the original publication¹. However, when establishing an adherence score based on all proposed parameters, no significant correlation was observed between publication year and adherence to the proposal made in 2007 (r_s -0.05; $p=0.75$). We did not identify frequent use of novel prognostic factors, such as (*K*)*RAS* and *BRAF* mutation status.

Conclusions: We observed persistent heterogeneity in reporting of patient characteristics and stratification factors in first-line mCRC trials published between 2009 and 2016. The proposal on standardized reporting of prognostic factors made in 2007 has not led to increased uniformity of the reporting of patient characteristics and use of stratification factors over time. There is an urgent need to address this issue in order to improve interpretation and comparison of trial results.

References:

¹ Sorbye H, Köhne C-H, Sargent DJ, Glimelius B. Patient characteristics and stratification in medical treatment studies for metastatic colorectal cancer: a proposal for standardization of patient characteristic reporting and stratification. *Ann Oncol* 2007;18:1666–72. doi:10.1093/annonc/mdm267.

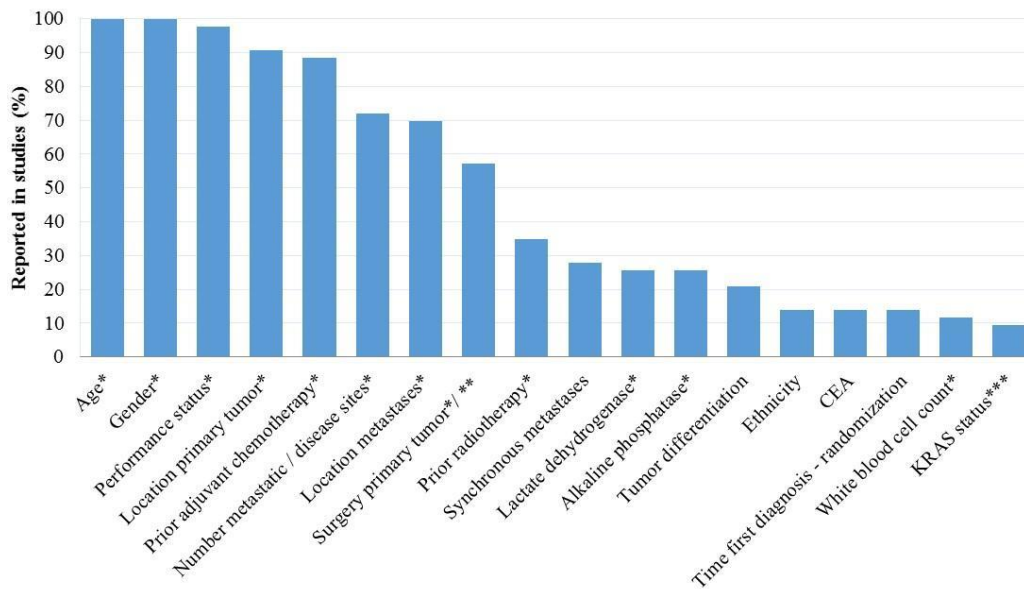

*Characteristics suggested by Sorbye *et al.*¹ **One study excluded enrolling only patients who underwent a primary tumor resection.
***One study excluded enrolling only patients with *KRAS* wild-type status.

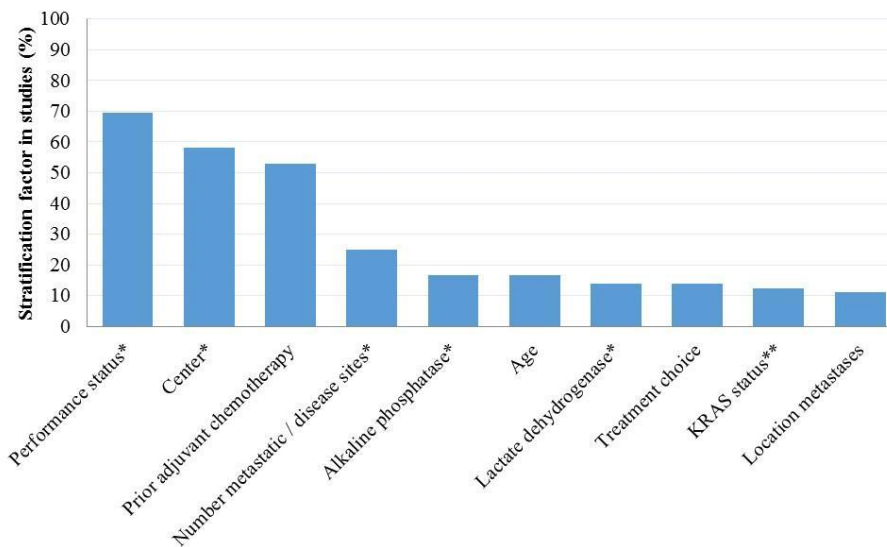

*Stratification factors suggested by Sorbye *et al.*¹ **One study excluded enrolling only patients with *KRAS* wild-type status.

P29

Glutamine Dipeptide vs Calcium Gluconate and Magnesium Sulfate in Preventing Neurotoxicity in Patients With Colorectal Cancer Receiving Oxaliplatin-Based Combination Chemotherapy

A. Ibrahim, A. Gabr

South Egypt Cancer Institute, ASSIUT, Egypt

Objective: Laryngopharyngeal dysesthesia and peripheral neuropathy are the major side effects of oxaliplatin, several attempts have been used to prevent them, recently several study reported efficacy of N2-LAlanyl- L-Glutamine Dipeptide in prevention neurotoxicity. So this study was conducted to compare the efficacy of parenteral glutamine dipeptide (N2-LAlanyl-L-Glutamine Dipeptide), with the use of calcium gluconate and magnesium sulfate in prevention of oxaliplatin induced neurotoxicity. **Patients and Methods:** A prospective study was done on 70 newly diagnosed patients with metastatic colorectal cancer (mCRC) all of them received FOLFOX-4 as first line treatment , 35 patients (group 1)received IV glutamine dipeptide (300 ml IV) before and after oxaliplatin administration on day 1 and other 35 patients (group2) received 2 vial of calcium gluconate vial 500mg with magnesium sulfate 500mg vial on day 1 also before and after oxaliplatin infusion . Laryngopharyngeal dysesthesia was assessed directly after each cycle and neurotoxicity symptoms and signs were evaluated before each cycle according to common terminology criteria for adverse events (CTCAE)ver.4 **Results:** there were no statistical significant difference between 2 groups in term of percentage of patients who complained from Laryngopharyngeal dysesthesia grade 3 &4 after administration of oxaliplatin 13% vs 14% p=0.070 ,also there were no statistical significant difference regarding grade 3&4 of peripheral neuropathy between 2 groups 9% vs 10.5 % p= 0.078 . With respect to tumor response to chemotherapy there were no significant difference regarding the overall response to treatment and progression free survival between 2 groups **Conclusion:** N2-LAlanyl- L-Glutamine Dipeptide can be used with oxaliplatin administration to decrease Laryngopharyngeal dysesthesia ,also it has good effect on decreasing peripheral neuropathy caused by oxaliplatin .

P30

Evolution of skeletal muscle mass (SMM) during palliative systemic treatment in metastatic colorectal cancer (mCRC) patients participating in the randomized phase 3 CAIRO3 study

S.A. Kurk¹, P.H.M. Peeters², B. Dorresteijn³, M. Jourdan³, H.J. Kuijff⁴, C.J.A. Punt⁵, M. Koopman¹, A.M. May²

¹University Medical Center Utrecht, UTRECHT, Netherlands

²Julius Center for Health Sciences and primary care, UTRECHT, Netherlands

³Nutricia advanced medical nutrition, UTRECHT, Netherlands

⁴Image Sciences Institute, University Medical Center Utrecht, UTRECHT, Netherlands

⁵Academic Medical Center, AMSTERDAM, Netherlands

Background

Observational studies suggest that low SMM is associated with chemotherapy-related toxicity and poor survival in mCRC patients. Little is known about patterns of SMM during palliative systemic therapy. Here we use data of the CAIRO3 study (Simkens et al. *Lancet* 2015) in which mCRC patients with stable disease or better after 6 cycles capecitabine+oxaliplatin+bevacizumab (CAPOX-B) were randomized between maintenance treatment with low dose schedule capecitabine+bevacizumab (CAP-B, M) and observation (O). In both groups CAPOX-B or other treatment was reintroduced upon disease progression until second disease progression, which was also the primary endpoint of CAIRO3. We used repeated scan data of 101 CAIRO3 patients to investigate SMM during treatment.

Methods

307 CT-scans of 101 randomly chosen CAIRO3 patients (63.1±9.0 years, M n=51; O n=50) were analyzed for SMM at four time points (i.e. prior to start pre-randomization induction treatment, at randomization, at first and at second disease progression) using single slice evaluation at L3. A linear mixed effects model was used to assess SMM changes both within and between study arms.

Results

Before CAIRO3 randomization during 6 cycles of CAPOX-B induction treatment, SMM decreased significantly in all patients (M: -0.8kg, (95% CI -0.14; -1.2) and O: -0.7kg (-0.4; -1.6)). After randomization, SMM recovered during maintenance treatment by 0.2kg (-0.3; 0.8) and observation -0.5kg (-1.1; 0.2) both compared to pre-induction SMM levels (median time 9.0 months and 4.3 months for M and O, respectively). After first progression and during reinduction treatment with CAPOX-B or other treatment, SMM again decreased significantly and similarly in both arms, M: -0.9kg (-0.1; -1.6), and O: -1.5kg (-0.8; -2.3) compared to pre-induction SMM levels (median time from first progression until second progression M: 4.7 months and O: 6.1 months).

Conclusion

Our preliminary data show that muscle loss in mCRC patients during palliative systemic therapy is reversible and varies with treatment regimen. Although studies have shown prognostic capacity for SMM, the effect of subsequent changes in SMM are unknown and may be clues for new future therapeutic interventions.

P31

Brain metastases from colorectal cancer. Patient characteristics and prognostic factors.

M.C. Pantin González, D. Gutierrez Abad, B. Anton Pascual, B. Losada Vila, C. Sanchez Cendra

Hospital Universitario de Fuenlabrada, MADRID, Spain

Background

Brain metastases(BM) are an uncommon complication of colorectal cancer (CRC) (1.8-5% of all BM). Overall survival(OS) after diagnosis of BM is 2.6 to 7.4 months(1).

In recent years, various articles have described the benefits of early surgical approach in selected patients with CRC and BM.

Methods

We reviewed all cases of BM in patients with CRC in the Hospital Universitario de Fuenlabrada in the last few years, comparing the results with those of the PUBMED articles published in the last 5 years, to describe the characteristics associated with increased risk of this kind of metastases in CRC and the best treatment approach in terms of OS. Due to not having enough patients for a statistical approach, a retrospective study is designed.

Results

In our area's population of 250,000 inhabitants, 492 patients have been diagnosed of CCR, 5 of which have developed BM, 3 men and 2 women, with an average age of 57.6 years [56 - 64]. About the location of the primary tumor, 3 out of 5 were from rectal origin, whereas 2 were from left colon neoplasias. KRAS was native in 2 of the cases, and mutated in other 2, being 1 unknown. The average level of CEA at BM diagnosis was 340 ng/ml [1.3 - 1630]. 1/5 did not develop lesions in other locations, 4/5 showed lung disease and 2/5 liver metastases.4 were treated with radiotherapy (RT) and 1 with both surgery and RT.(Figure 1).

Discussion and conclusions

Our results are consistent with those of the systematic review of TD Christensen et al (1) in terms of average age and location of the primary tumor. Also, in both studies, the incidence of liver, lung and brain metastases was higher in left colon tumors (100% appear in left colon/rectum) (2,3).

Our study shows an average time of 67 months (0-109) from primary tumor diagnosis to the appearance of BM, which is longer than the one showed in TD Christensen (20-40 months) and Ko FC (33 months).

Survival from the onset of BM is between 15 days and 34 months in our sample, a range much higher than TD Christensen(2.6 to 7.4 months).

In terms of presence of extracerebral metastases, our results are also consistent with other studies (20% shows BM as the unique location of metastatic disease), being lung metastases the most frequent (4/5) (1,3). Comparing our results with Ko FC, OS rates in CRC with BM is increased in patients treated with surgery (> 34 months and 86 months [8-191]) than in those who only received RT (1.12 months in our sample and 2.9 months in Ko FC).

Development of BM is associated with primary rectal tumors, metastatic lung disease and mutated kRAS. OS in patients with single brain metastasis is 5.7 months, compared to 3 months when there were>2 brain lesions(4).

To conclude: risk factors for developing BM in CRC should be considered to achieve an early diagnosis, being able to select suitable patients for an aggressive surgical resection, which could improve their survival rate.

% patients treated with radiotherapy	80% (4/5)	47% (3)
% patients treated with surgery + radiotherapy	20% (1/5)	11,32% (3)
Survival after surgery of BM	> 34 months	86 months [8-191] (3)
Survival after radiotherapy of BM	1,12 months [15 days – 2 months]	2,9 months [1-82] (3)

Table 1. Information about: location of the primary tumor and BM, age, sex, neurological symptoms, interval from primary CCR diagnosis to BM diagnosis , mean survival time from the appearance of BM , metastatic disease, laboratory parameters (KRAS and CEA) at BM diagnosis, patients treated with surgery of BM and/or radiotherapy and survival after such interventions.

Table 1. Information about: location of the primary tumor and BM, age, sex, clinical neurological, interval from primary CCR diagnosis to BM diagnosis

	OUR CASES					PUBLISHED SERIES
Incidence of BM (brain metastases) from colorectal cancer (CRC)	5/492 = 24,6%					0,6 – 3,2%
Location of the CRC	Left colon	Rectum	Left colon	Rectum	Rectum	The frequency of rectal cancer patients with BM varies between 40 - 60 % (1). In other series, the average frequency was 62.26 % (2)
Location of the BM	Right cerebellum	Right and left occipital lobes	Left frontal and left parietal lobes	Left parietal lobe and right cerebellum	Left frontal lobe	<ul style="list-style-type: none"> • 62% temporo-parieto-occipital lobes • 13% cerebellum only • 8% frontal lobe (3)
Interval from primary CRC diagnosis to BM diagnosis	67 months [0 – 109]					20 – 40 months (1) 33 months (3)
Survival from the diagnosis of BM	From 15 days to 34 months (1020 days)					2,6 – 7,4 months (1) 2,9 months (3)
Neurological symptoms	Dizziness	Diplopia	Impaired swallowing	Ataxia	Cognitive impairment and right hemiparesis	<ul style="list-style-type: none"> • Mental status change (41,5%) • Limb weakness (30%) • Headache (18,8%) (3)
Sex	60% male (3/5) and 40% female (2/5)					39 – 80% male (1) 73,58% male (3)
Average age	57,6 years [56 – 64]					56 – 73 years (1)
CEA levels at BM diagnosis	340 ng/ml [1,3 – 1630]					CEA was increased >5 ng/mL at BM diagnosis in 70% of the patients (1)
kRAS	Unknown	Native	Mutation	Mutation	Native	kRAS mutations have been associated with both increased incidence of BM and lung metastases (1)
Metastases in other locations	80% lung (4/5), 40% liver (2/5)					87,7%: 70% lung, <45% liver (1)

Table 1. Information about: location of the primary tumor and BM, age, sex, clinical neurological, interval from primary CCR diagnosis to BM diagnosis

P32

Evaluation of guideline adherence in colorectal cancer treatment in The Netherlands: a survey among medical oncologists by the Dutch Colorectal Cancer Group (DCCG)

L. Keikes¹, M.G.H. Van Oijen¹, V.E.P.P. Lemmens², M. Koopman³, C.J.A. Punt¹

¹Academic Medical Center, AMSTERDAM, Netherlands

²Comprehensive Cancer Center (IKNL), EINDHOVEN, Netherlands

³University Medical Center Utrecht, UTRECHT, Netherlands

Objectives. Clinical guidelines with corresponding recommendations are generated to preserve high quality evidence-based care. In 2014, several adjustments for the systemic treatment in the adjuvant and metastatic setting were introduced in the Dutch colorectal cancer guidelines. Data on the implementation of guidelines into clinical practice are scarce, despite the fact that guideline adherence is known to prevent over- and undertreatment and is related to survival. Therefore, the aim of this survey is to investigate adherence to the Dutch guidelines for the systemic treatment in high risk stage II and stage III colon cancer and metastatic colorectal cancer. **Methods.** In all Dutch hospitals (n=88) one medical oncologist involved in colorectal cancer care was approached to participate. An online survey was conducted regarding the local standard of care for adjuvant chemotherapy in high-risk stage II and III colon cancer and for treatment regimens in metastatic colorectal cancer. Frequency tables were provided for categorical variables and Fisher's exact tests were performed to compare differences in guideline adherence according to hospital type (academic versus teaching versus regional hospital). **Results.** The overall response rate was 70% (62/88). Adherence to guidelines was at least 60% in all settings that were presented. In high-risk stage II and stage III colon cancer, reported treatment strategies agreed with the national guidelines in 66% and 82% of hospitals, respectively. Disparities mainly concerned the implementation of mismatch repair status in treatment selection which resulted in overtreatment of 28% of hospitals in high risk stage II and 13% in stage III colon cancer. The main disparity in the treatment of metastatic disease concerned the use of targeted drugs as part of first-line treatment regimens according to the guidelines. Bevacizumab was not administered in 37% of hospitals in patients with permanently unresectable metastases and no targeted drug was administered in 29% of hospitals in patients with initially unresectable but potentially resectable metastases. No difference in guideline adherence was observed between the different types of hospital. **Conclusions.** Guideline adherence as reported by medical oncologists in The Netherlands leaves room for improvement. Suboptimal adherence was observed in the implementation of mismatch repair status in the selection of adjuvant treatment in high-risk stage II and stage III colon cancer as well as the use of targeted drugs as part of first-line treatment regimens in metastatic patients. Reasons for nonadherence have not been enough revealed, but unawareness or disagreement with the guidelines with or without financial restrictions are speculative explanations. Our results demonstrate that more attention should be paid to guideline adherence in clinical practice, and in case of nonadherence to underlying causes.

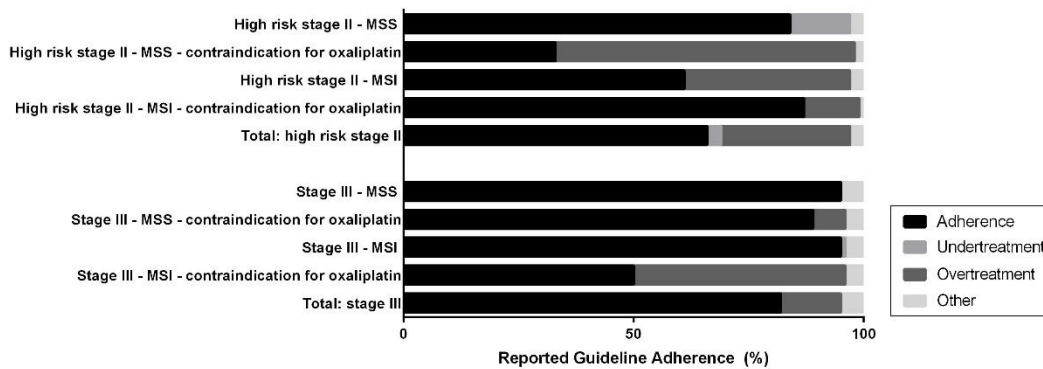

Overview of adherence, overtreatment and undertreatment patterns for high risk stage II and stage III colon cancer

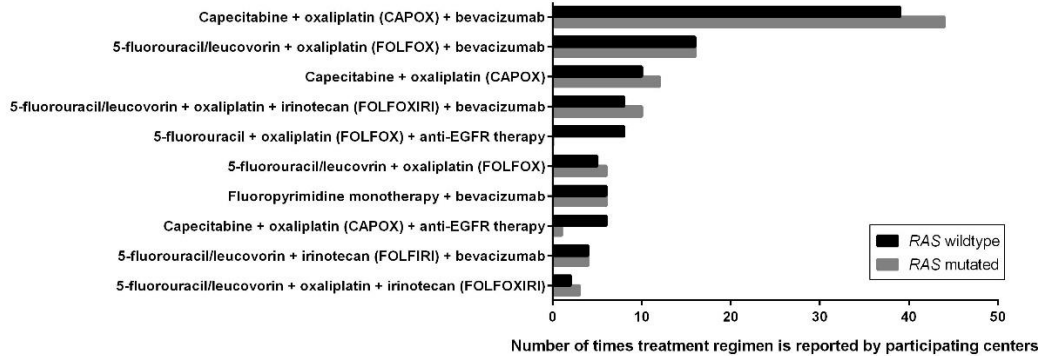

Top 10 ranking of first line preferred treatment regimens for patients with initially unresectable but potentially resectable metastases

P33

Prognostic determinant of distant metastasis in patients with surgical resectable rectal cancer and having no distant metastases at time of surgery.

S. Elabd, H. Shabana, D. Gough, C. Oboyle, B. Whooley

Bon Secours Hospital in Cork, CORK, Ireland

Background: The major prognostic determinants of rectal cancer is the pathologic stage, since 1987 American Joint Committee on Cancer [AJCC] has proposed a worldwide categorization of cancer staging [TNM].

Aim: Does TNM staging predict people at risk of having distant metastases? follow up value of CEA in rectal cancer. how long should rectal cancer be followed up?

Methods: We reviewed 300 patients presented to Bon Secours hospital from 2000 till 2013 of which 100 have been selected based on having [undergone curative surgery for rectal cancer and had no distant metastases at time of diagnosis]

Results: The average age was 72, 40% were female. At median follow up of 4.8. Distant metastases was detected in 32 while 7 had local recurrence. Percentage of distant metastases was 45% in nodal positive tumor, 24% in nodal negative disease, 16% in Tis, 18% T1, 45% T3, 0% in T4 tumors. 21% of distant metastases had occurred after 1 year, 25% 2 years, 18% 3 years, 18% 4 years, 10% 5 years, 6% after 6 years. Patients were followed up with CEA for a mean of 5 years and had shown little impact as a marker for distant metastases.

Conclusion: Rectal cancer is heterogeneous in survival pattern even within staging categories. prognostic power of tumor invasion and nodal status is debatable. follow up of rectal cancer should be continued beyond 5 years regardless tumor stage and the recurrence free follow up period.

P34

Colic Vanek's tumor. A case report

K. Sassi, R.H. Hassine, A.C. Abdelhedi, S.A. Sridi, C.A. Chouchene

Interior security forces Hospital, LA MARSIA, Tunisia

Introduction: inflammatory fibroid polyps, or Vanek's tumor, are rare tumors of the gastrointestinal tract. Colorectal location represents only 4-7% of cases. Observation: 69-year-old woman with no medical history, was hospitalized for a painful and febrile syndrome of the right iliac fossa and the right flank associated with diarrhea lasting for two

days. The review was a defense of the right side with a low-grade fever to 38.2 ° C . Biology objectified leukocytosis 12,000 / mm³ with an inflammatory syndrome. The exploration by CT scan had objectified just a fat infiltration against the right colon. The appendix was fine without inflammatory signs. The patient was operated laparoscopically. A préperforative lesion of 3 cm, located 5cm below the hepatic flexure, was found. Induration of the wall below was palpated making suspect a colic underlying tumor. Right hemicolectomy was performed oncologically with iléotransverse anastomosis. The postoperative course was uneventful. Histopathological analysis of the surgical specimen was found a Vanek's tumor. Conclusion: Colic Vanek's tumor is a rare benign lesion and difficult to diagnose preoperatively. It can simulate a colon cancer because of the absence of clinical specificity, endoscopic or radiological leading to extensive resections for benign lesion. Endoscopy and endoscopic biopsies are often not contributory. The diagnosis is rarely mentioned before the histopathological confirmation

P35

The potential benefits of the liver-first approach in patients with rectal cancer and synchronous liver metastases.

P.M.H. Nierop¹, B. Galjart¹, M. Verseveld¹, J. Rothbarth¹, J.W.A. Burger², D.J. Grünhagen¹, C. Verhoef¹

¹Erasmus MC Cancer Institute, ROTTERDAM, Netherlands

²Erasmus MC - University Medical Center, ROTTERDAM, Netherlands

Objectives

Patients with colorectal cancer (CRC) and synchronous colorectal liver metastases (sCRLM) can be treated according to the liver-first approach. This means that the hepatic metastases are treated before the primary tumour, which is in contrast to the traditional treatment sequence.

A considerable proportion of patients with sCRLM and rectal cancer cannot be cured, because of the development of extensive metastases. In these patients it might be beneficial to treat CRLM first and to spare them from the morbidity of extensive low pelvic surgery.

Nowadays there is a special interest in rectal sparing surgery or even wait and see policy in patients with rectal cancer after an adequate response on induction therapy. However, this hypothesis has not been evaluated in patients with stage IV disease.

The present study describes the largest series of patients treated according to the liver-first protocol currently available in the literature. It aims to determine which proportion of patients completes potentially curative treatment. Secondly, this study aims to evaluate what proportion of the patients were spared from the morbidity of extensive lower pelvic surgery.

Methods

This is a retrospective analysis of all patients treated for rectal adenocarcinoma with sCRLM at the Erasmus MC Cancer Institute according to the liver-first protocol. In all patients not completing the full treatment protocol, the proportion not needing additional surgical treatment for the primary tumour was assessed. For patients completing the full trajectory pathological TNM-stage was evaluated, in order to determine if rectum sparing surgery (i.e. transanal endoscopic microsurgery (TEM)) or watchful waiting could have been suitable.

Results

In total 132 consecutive patients starting treatment for sCRLM and rectal adenocarcinoma between May 2003 and March 2015 were included in this study. The majority of patients completed the full treatment trajectory (90 patients, 68.2%). Median follow-up time of the total group was 24.5 months. Of all patients not completing the full protocol (42 patients, 31.8%) one patient required palliative low pelvic surgery, due to severe pain symptoms. One patient did undergo preventive resection of the rectal tumour, because of unexpected intraoperatively detected disease progression.

Pathological assessment of the primary tumour in patients completing the protocol showed that 16 patients (17.8%) had (y)pT0N0 or (y)pT1N0 tumours. Hypothetically these patients could have been treated with rectum sparing surgery. Recent literature indicates that for these tumour stages watchful waiting also could have been a suitable approach.

Of all 132 patients, 40 patients did not have low pelvic surgery because of the development of extensive metastases and 16 patients had a ypT0/T1N0 tumours, which could have been treated with rectal sparing surgery or watchful waiting. In retrospect low pelvic surgery did not seem warranted in 56 patients (42%).

Conclusion This study shows that the liver-first approach for sCRLM and rectal adenocarcinoma is a suitable approach. It may reduce the morbidity associated with lower pelvic surgery in both patients completing and not completing the full treatment trajectory.

P36

Is bevacizumab safe in colorectal cancer patients with bowel stent?

C.M. Im¹, J.W. Kim², H.K. Oh², C.J. Yoon¹, N.J. Seong¹, Y.S. Park¹, H. Yoon¹, D.W. Kim¹, K.W. Lee², J.H. Kim², K.H. Lee¹, S.B. Kang², J.S. Kim¹

¹Seoul National University Bundang Hospital, SEONGNAM-SI, South Korea

²Seoul National University Bundang Hospital, SEONGNAM, South Korea

Objectives

The efficacy of bevacizumab in metastatic colorectal cancer has been proved through several clinical trials. Meanwhile, bevacizumab also increases the risk of bowel perforation in colorectal cancer. The safety for the use of bevacizumab in patients with bowel stent is not well-defined.

Methods

Between Jan. 2003 and July 2016, colorectal cancer patients inserted bowel stent due to bowel obstruction were collected through electronic medical records including endoscopic and radiologic interventions. Chemotherapy regimen and bowel perforation event were identified.

Results

In 313 patients with colorectal cancer, bowel stents were inserted. Patients surgically removed bowel stent before chemotherapy (170) were excluded in this final analysis. Of 143 patients, 56 patients (39.2%) did not receive further chemotherapy. In 61 patients (42.7%) and 26 patients (18.2%), chemotherapy without and with bevacizumab was applied respectively. The most frequent locations of stent was sigmoid colon [ascending colon, 12 (8.4%); hepatic flexure, 5 (3.7%); transverse colon, 9 (6.6%); splenic flexure, 5 (3.7%); descending colon, 10 (7.4%); sigmoid colon, 51 (37.5%); rectosigmoid colon, 19 (14.0%); rectum, 24 (17.6%); transverse colon and sigmoid colon, 1 (0.7%)]. Perforation events were identified in 11 patients (7.7%). Patients with chemotherapy with bevacizumab (6/26, 23.1%) showed bowel perforation events more frequently than patient without bevacizumab (1/61, 1.6%) or no chemotherapy (4/56, 7.1%), significantly ($p=0.003$). Rectosigmoid colon was the most frequent site of bowel perforation (15%). However, there was no difference according to tumor sites.

Conclusions

In colorectal cancer patients with bowel stent, chemotherapy with bevacizumab increased the risk of bowel perforation. Bevacizumab should be avoided or be applied with caution in patients with bowel stent.

P37

Left colon tumor locally advanced invading the abdominal wall

F.A. De Sá Ribeiro

UERJ, RIO DE JANEIRO, Brazil

Colorectal cancer is one of most neoplasia frequent in the adult population worldwide; among cancers of the gastrointestinal tract is the second in prevalence and mortality. The colon-rectal adenocarcinomas are essentially surgical tumors, in which the extended resection in patients with locally advanced disease exclusive, are justifiable in terms of survival, provided they get clear margins. The aim of the present article is to report an unusual case of left colon tumor locally advanced that invades the abdominal wall. Case report: A 52-year-old female patient complaining of abdominal mass and pain associated since May 2010. The patient was admitted to the Emergency of the ward I Surgical Clinic of the Federal Hospital Bonsucesso - Rio de Janeiro - Brazil, in January 2011 with fever and abdominal distension. The laboratory tests showed leukocytosis and computed tomography (CT) showed suggestive of pericolic abscess. Percutaneous drainage was performed with exit bloody and purulent secretion. The patient showed partial improvement of symptoms and was discharged with ambulatory monitoring. Two months later a new CT showed an suggestive tumor of abdominal wall without limits defined with the left colon. The patient developed worsening pain and increased abdominal size plus weight loss. An incisional biopsy was performed of abdominal mass in left hypochondrium in the region and the report suggested fibromatosis. Colonoscopy showed exophytic lesion in the lumen of the left colon. Symptoms progressively worsened with fecal material output by the biopsy site associated with skin infection. Was made debridement of the lesion and deepening of incisional biopsy. The histopathologic diagnosis of colonoscopy and this last biopsy was colon adenocarcinoma. Thought this work we conclude that the surgical approach selected for the case brought resolution to the pathology presented by the patient and she is free of disease three years and no signs of tumor recurrence. Ribeiro, Flávio A. de Sá; Urquiaga, Bárbara de O; Souza, Flavia S.T.; Tenório

P38

A Comparative Study Among Elective Conventional Surgery, Urgency/Emergency Conventional Approaching and Elective Videolaparoscopic Surgery with a Diagnostic of Colorectal adenocarcinoma, between January 2010 and December 2012

F.A. De Sá Ribeiro

UERJ, RIO DE JANEIRO, Brazil

A retrospective study realized at First Surgeric Clinic of Federal Hospital of Bonsucesso, on ward in patients with a diagnostic of colorectal adenocarcinoma hospitalized between January 2010 and December 2012, and followed outpatients until December 2013 (227 patients). The patients were divided into three groups: those who were submitted to a conventional resection (152 patients), those who were submitted to a videolaparoscopic approaching (57 patients) and finally those who, while the ward hospitalization needed an emergency approaching because of an obstruction and/or bleeding (27 patients). Each group was analyzed in relation to age, time of hospitalization, postsurgical staging and complications (Clavien's Classification). The groups were compared among themselves evaluating the comparative significance of the studied variables. The statistical evaluation highlighted three variables: time of hospitalization, complications and staging. Most of the patients who were submitted to an emergency surgery had a shorter time of hospitalization ($p=0,00000497$). The lower incidence of complications was related to the group who was submitted to the videolaparoscopic surgery ($p=0,002072$). On the elective conventional surgeries the percentage of death was high. Besides, a high percentage of patients submitted to the videolaparoscopic surgery was in earliest stages of the disease. On the other hand, as expected, a high percentage of patients submitted to the emergency surgery was in more advanced stages of the disease ($p=0,047$).

P39

Differences in robotic surgery outcomes in obese versus non-obese colectomy patients

M. Schootman¹, S. Hendren², T. Loux¹, K. Ratnapradipa¹, J.M. Eberth³, N.O. Davidson⁴

¹Saint Louis University, ST LOUIS, USA

²University of Michigan, ANN ARBOR, USA

³University of South Carolina, COLUMBIA, USA

⁴Washington University, ST LOUIS, USA

Objectives

We examined differences in peri- and post-operative outcomes of robot-assisted surgery (RAS) for colectomy for colon cancer (with or without obstruction) or nonmalignant polyps in obese versus non-obese patients.

Methods

We used the 2013–2014 American College of Surgeons' National Surgical Quality Improvement Program data to examine operative outcomes (conversion, operation time, anastomotic leakage) and postoperative outcomes (mortality, readmission, re-operation, length of stay, wound infection, bleeding occurrence, prolonged postoperative ileus). Patients underwent total colectomy for colon cancer (with or without obstruction) or nonmalignant polyps. Patients with ASA class 5 or who underwent emergent colectomy were excluded from the analysis. We constructed a composite outcome of mortality, readmission, re-operation, wound infection, bleeding occurrence, and prolonged postoperative ileus. We used propensity scores to assess potential heterogeneous treatment effects of robotic surgery for male and obese patients.

Results

Over 12% ($n=911$ of 7,339) of patients received RAS. In adjusted analysis, patients were more likely to receive RAS if they were male, had surgery in 2014, younger, white, non-smokers, had stage 0 colon cancer, lower ASA category, and no comorbid conditions. Obese and non-obese patients were equally likely to receive robotic surgery. In adjusted analysis of all patients, postoperative outcomes were similar ($p>0.05$) in RAS versus non-RAS patients. Length of stay and operation time were an average 0.3 days ($p>0.05$) and 62 minutes ($p<0.05$) longer in RAS patients versus non-RAS patients, respectively. RAS patients had 11.3% lower conversion to open surgery than non-RAS patients ($p<0.05$).

For obese patients, unadjusted adverse postoperative outcomes were 21.7% for RAS surgery and 23.0% for non-RAS ($p>0.05$). For nonobese patients, adverse postoperative outcomes were 24.3% when receiving RAS and 21.0% with non-RAS ($p>0.05$). In adjusted analysis, the effect of RAS patients on postoperative outcomes was more pronounced (6.8% lower) in obese versus nonobese patients ($p=0.05$). The length of operation and the conversion to open surgery was similar between obese and nonobese patients when receiving RAS ($p>0.05$).

Our findings were robust with respect to the reason for colectomy (malignant or nonmalignant polyps), different methods of propensity score matching, and the definition of the RAS and non-RAS groups.

Discussion

RAS was associated with reduced adverse postoperative outcomes in obese versus non-obese patients. Although RAS reduced overall conversion rates and increased average length of operation by over an hour, this was similar between obese and nonobese patients. It is unlikely that increasing robotic surgery among obese patients will disproportionately reduce their high conversion rates, but RAS may reduce postoperative outcomes among obese patients.

P40

Alternative types of two-stage liver resections (PVL and ALPPS) for liver metastases of colorectal cancer: preliminary results of 30 cases.

L.O. Petrov¹, D.V. Sidorov¹, M.V. Lozhkin¹, A. Isaeva²

¹P. Hertsen Moscow Oncology Research Institute, MOSCOW, Russia

²Hertsen Moscow Oncology Research Institute, MOSCOW, Russia

Objectives: The aim of this study is to compare the intermediate oncological outcomes after ALPPS vs PVL in patients with CRLM.

Methods: Thirty patients undergoing two-stage hepatic resection at the abdominal oncology department P.HERZEN MORI from January 2012 to January 2016 were analyzed. Indications for surgical resection were metastases from colorectal cancer in all cases.

Results: 15 patients (6 male, 9 female), age 57±11.6 years (39-75) were operated by portal vein ligation (PVL) techniques for 5±3 (2-10), metastases of which the largest was 58±27 mm (30-122). Eleven (73,3%) patients received neo-adjuvant chemotherapy. The median volume of the FLR before PVL was 278,3±73,6 mL (28±8.3%) and 333.5±69.7mL (34.7±4.9%) before the second step. After the first stage of hepatic resection FLR increased by 59.5±65.9% (5-166%, p<0.05). The second stage of hepatic resection was performed in 10 (66.7%) patients. The time between two steps of the procedure was 72.3±32.8 days. There were no cases of liver failure. For stage 2, operation time was 291±74.3 min and estimated blood loss 1428.5 ml (400-3000).

ALPPS was initiated in 15 patients whose mean age was 59±6.3 (49 -72) years. One patient had salvage ALPPS after failed PVL. Patients were operated for 2.8±1.6 metastases of which the largest was 64.6±18.8 mm (40-104). The FLR volume was 313±120 mL (26±7%) before ALPPS-1 and 503±128 mL (43±7%) before ALLPS-2 (p<0.001). The increase in FLR between the two procedures was 95.3±53.6% (range: 13-164%, p<0.001). The average time between the first and second step of the procedure was 9.4±1.4 days. There were 2 (13,3%) postoperative deaths after ALPPS-1 due to hepatic failure. The second surgery had a surgical time of 105.5±35.5 min, an average volume of blood loss 281.2 ml (100-1000).

23 patients in both groups underwent the second stage of hepatectomy. The predominant cause for mortality of one patient in PVL group and two patients in ALPPS group between stages was postoperative liver failure. Unsuccessful left liver growth was observed in 2 (13.3%) patients after PVL-1. Two patients (13.3%) of PVL group were excluded due to the tumor progression between the stages.

Conclusions: Associating liver partition and portal vein ligation for staged hepatectomy (ALPPS) allows to achieve the fast and high level of FLR growth. So, this novel procedure seems to be more effective than conventional two-stage hepatectomy with portal vein ligation (PVL), but it can be associated with high mortality and morbidity rates. However, there is no enough data about long-term results of ALPPS.

Keywords: Colorectal cancer; Liver metastasis; Two-stage hepatectomy; ALPPS; PVL

P41

Long-term results of TME for rectal cancer: prospective single-center study

L.O. Petrov¹, D.V. Sidorov¹, M.V. Lozhkin¹, A.A. Troitskiy¹, A. Isaeva²

¹P. Hertsen Moscow Oncology Research Institute, MOSCOW, Russia

²Hertsen Moscow Oncology Research Institute, MOSCOW, Russia

Objectives The aim of this study was to assess 7-year oncologic outcomes after TME for rectal cancer.”◆

Methods From June 2006 to August 2009, 112 patients with rectal cancer who had undergone TME in our center were assessed. The primary endpoints were disease-free survival and overall survival according to postoperative histopathological CRM examination. All operations were performed by the same team of surgeons. All surgical specimen was sent for histopathological examination which included macroscopic assessment of the rectal fascia propria to determine its completeness and thus its quality using the criteria proposed by Quirke. A microscopic examination was carried out to determine the state of the circumferential resection margin. Overall survival (OS) and disease-free survival (DFS) were compared by using the Kaplan–Meier method. A multivariable analysis was performed to identify predictors of poor survival.

Results Oncological results of 87 (78%) patients were available. Medium follow-up of surviving patients was 4.1 year. Five-year local recurrence risk of patients undergoing a macroscopically complete local resection was 5.6% in case of the negative circumferential resection margin compared with 10.9% in patients with positive CRM ($P < 0.001$) (Fig.1). Overall survival at 5 years was 84.2% and 48.5%, respectively ($P < 0.001$). 7-years overall survival was 78.2% and 47.3% ($P < 0.001$). Median time to relapse was 1.4 years (range 0.8–5.0) for local recurrence and 3.4 years (0.8–7.5) for distant recurrence. Grade I quality of TME is associated with poorer long-term prognosis vs Grade II-III ($p=0.04$). (Fig.2)

Discussion / Conclusion

A positive CRM and low quality of TME were confirm to be a negative prognostic factors for overall survival of rectal cancer patients after surgical treatment.

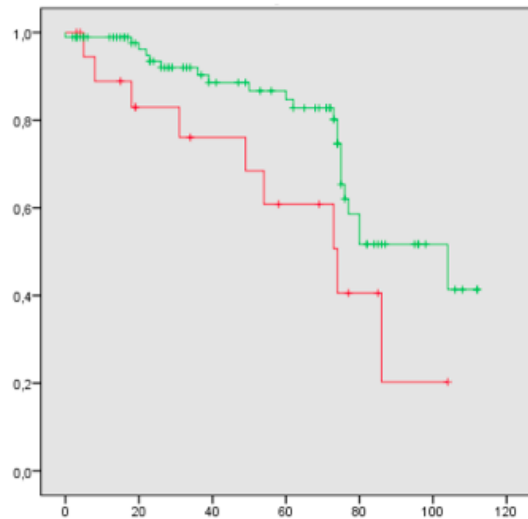

Fig.2 Overall survival after total mesorectal excision (Long-rank test)

— Grade I — Grade II - III

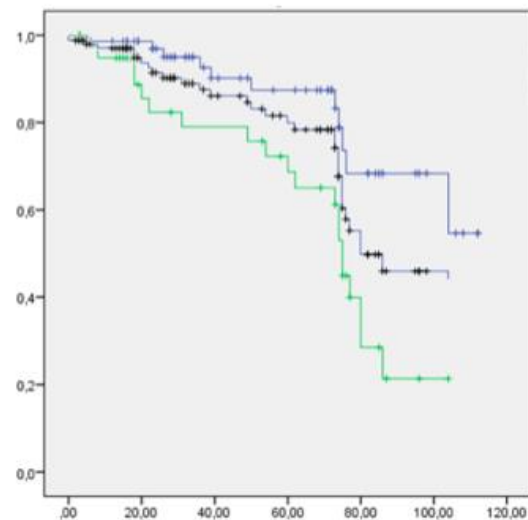

Fig.1 Overall survival after total mesorectal excision (Long-rank test)

- All patients - CRM + - CRM -

P42

Resection of rectal tumours: Natural course after transanal endo-scope microsurgery (TEM) with or without completion total mesorectal excision (TME) for T2 and T3 rectal carcinoma.

T.W.A. Koedam¹, J.W.A. Leijtens², W.A.A. Borstlap³, M. Maas⁴, P.G. Doornebosch⁵, T.M. Karsten⁶, E.J. Derksen⁷, L.P.S. Stassen⁴, C. Rosman⁸, E.J.R. De Graaf⁵, A.J.A. Bremers⁸, J. Heemskerk⁹, G.L. Beets¹⁰, J.B. Tuynman¹¹, K.L.J. Rademakers⁸

¹VUmc, AMSTERDAM, Netherlands

²St. Laurentius Ziekenhuis, ROERMOND, Netherlands

³Academic Medical Center, AMSTERDAM, Netherlands

⁴Maastricht University Medical Center, MAASTRICHT, Netherlands

⁵IJsselland Ziekenhuis, CAPELLE AAN DEN IJSSEL, Netherlands

⁶OLVG, AMSTERDAM, Netherlands

⁷MC Slotervaart, AMSTERDAM, Netherlands

⁸Radboud University Medical Center, NIJMEGEN, Netherlands

⁹Laurentius, ROERMOND, Netherlands

¹⁰Netherlands Cancer Institute, AMSTERDAM, Netherlands

¹¹VU University Medical Center, AMSTERDAM, Netherlands

Background: Transanal endoscopic microsurgery (TEM) is used for resection of large rectal adenomas and well or moderately differentiated T1 carcinomas. Due to difficulty in staging, locally excised carcinomas sometimes appear to be a more advanced carcinoma than expected. Although completion total mesorectal excision (TME) is generally considered standard of care, some of these patients prefer a watchful waiting policy. The aim of this study was to determine oncologic outcomes of both treatment modalities.

Methods: In this retrospective multicenter, observational cohort study, outcome after rectal preserving (N=41) and completion surgery (N=40) following TEM of a pT2-3 rectal adenocarcinoma were compared. Our main aim was to assess oncologic outcome in terms of local and distant recurrence, overall survival and disease specific survival. Secondary, treatment related morbidity of the TEM and completion TME procedures was analyzed.

Results: The median follow-up was 29 months for the rectal preserving group and 31 months for the completion surgery group. The median age was 81.0 (SD8.7) and 65.5 (SD9.8) years, respectively ($p < 0.001$). A pT2 rectal carcinoma was reported in 67/81 (83%) patients, 35/41 (85.4%) patients in the rectal preserving group and 32/40 (80.0%) patients in the completion TME group. In the rectal preserving group 6/41 (14.6%) were a pT3 carcinoma versus 8/40 (20.0%) in the completion group. Local recurrence rate was 27% (11/41) and 13% (5/40), respectively ($p = 0.105$). Distant metastasis occurred in 5/41 (12%) and 6/40 (15%; $p = 0.713$), respectively. The 3-year overall survival was 63% in the rectal preserving group and 91% in the completion surgery group respectively ($p=0.001$). However, the 3-year disease specific survival was 91% versus 95%, respectively ($p=0.40$).

Conclusions: Although oncological outcome after TEM alone for pT2-3 rectal cancer is worse compared to completion surgery, this can be a valid alternative in old and comorbid patients, especially when high morbidity of completion surgery in this specific group is taken into consideration.

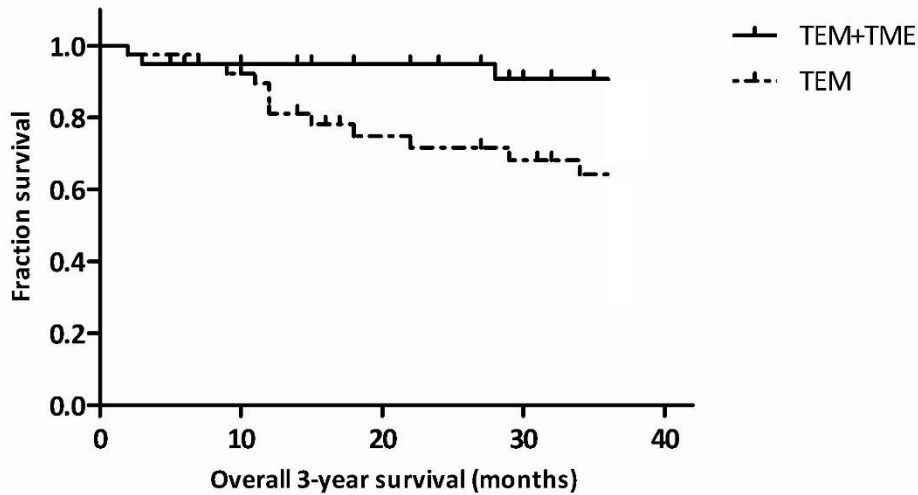

Fig. 1 Overall 3-year survival in months

Overall survival at 3-year follow-up

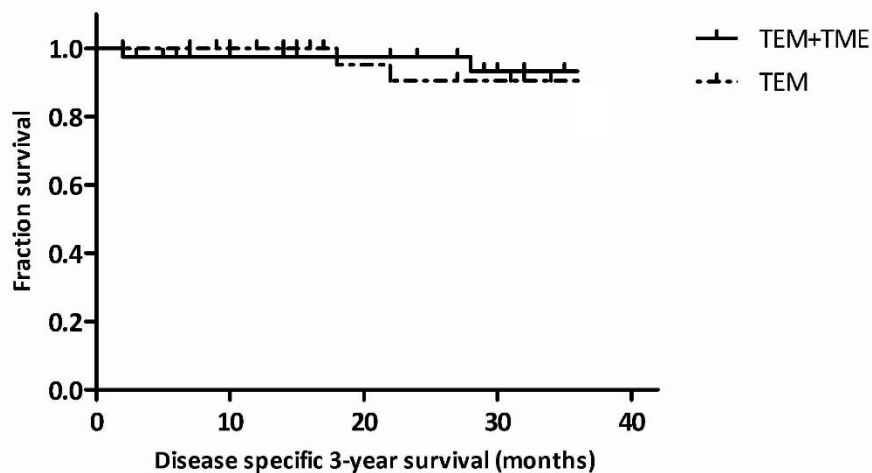

Fig. 2 Disease specific 3-year survival in months

Disease-specific survival at 3-year follow-up

P43

A prospective validation of a clinical decision guideline for the treatment of obstructing left-sided colon cancer: the CONSTRUCT registry

E.E. Van Halsema¹, P.J. Tanis¹, W.A. Bemelman¹, F. Ter Borg², E.C.J. Consten³, P. Fockens¹, P.D. Siersema⁴, E.S. Van der Zaag⁵, J.E. Van Hooft¹

¹Academic Medical Center, AMSTERDAM, Netherlands

²Deventer Hospital, DEVENTER, Netherlands

³Meander Medical Center, AMERSFOORT, Netherlands

⁴Radoud University Medical Center, NIJMEGEN, Netherlands

⁵Gelre Hospitals, APELDOORN, Netherlands

Objectives. Our objective is to validate a clinical decision guideline for the treatment of obstructing left-sided colon cancer. By implementing this decision guideline, we aim to reduce the postoperative mortality in the elderly and frail patients.

Methods. In this nationwide multicenter prospective registry, all patients with obstructing left-sided colon cancer, who consent to the use of their medical data, are included. The left-sided colon includes the splenic flexure up to 10 cm from the anal verge. Patients are treated according to a clinical decision guideline that is based on the revised Dutch national guideline and European Society of Gastrointestinal Endoscopy clinical guideline for the use of colonic stents. For implementation and educational purposes, 61 experienced interventional endoscopists from 36 hospitals participated to the CONSTRUCT training. Training consisted of a theoretical training in the clinical decision guideline followed by a hands-on training with the Evolution Colonic Uncovered Stent (Cook Medical, Limerick, Ireland) using a colonic obstruction model at the endoscopy ward with fluoroscopic guidance. Forty-nine endoscopists with a lifetime experience of at least 20 colonic stent procedures were subsequently certified for colonic stenting in the CONSTRUCT registry. The clinical decision guideline for the treatment of obstructing left-sided colon cancer is presented in **figure 1**. In summary, young and fit patients (age < 70 years and American Society of Anesthesiologists (ASA) status ≤ 2) with a potentially curable obstruction are subjected to acute resection. The elderly and frail patients (age ≥ 70 years or ASA status ≥ 3) undergo initial decompression by endoscopic stent placement or transverse colostomy by a local surgical procedure. Following initial decompression, patients are scheduled for elective resection of the primary tumor within 4 weeks. Patients presenting with extensively metastasized incurable disease, irrespective of age, receive a colonic stent or a transverse colostomy as palliative treatment of their obstructing tumor. Data are extracted from medical records up to 1 year of follow-up. In case of missing data, family doctors are contacted to complete follow-up. The primary endpoint of the registry is the 30-days postoperative mortality in the bridge to surgery group, which will be compared with historical cohort data from the Dutch Surgical Colorectal Audit, a nationwide obligatory registry of all colorectal cancer resections. Secondary endpoints include stent- and surgery-related morbidity, stoma rates, disease recurrence and overall survival. We aim to include 195 patients.

Results. Between January 2015 and August 2016 a total of 101 patients from 21 hospitals have been included so far. Eight (8%) patients underwent acute resection. Fifty-six (55%) patients received bridge to surgery treatment by stent placement (40; 71%) or colostomy (16; 29%). Thirty-seven (37%) patients were treated palliatively by stent placement (26; 70%), colostomy (10; 27%) or acute resection (1; 3%).

Discussion / Conclusion. The use of this clinical decision guideline is a helpful tool to optimize and standardize the treatment of obstructing left-sided colon cancer. By validating these recommendations, we hope to reduce the postoperative mortality in the elderly and frail patients.

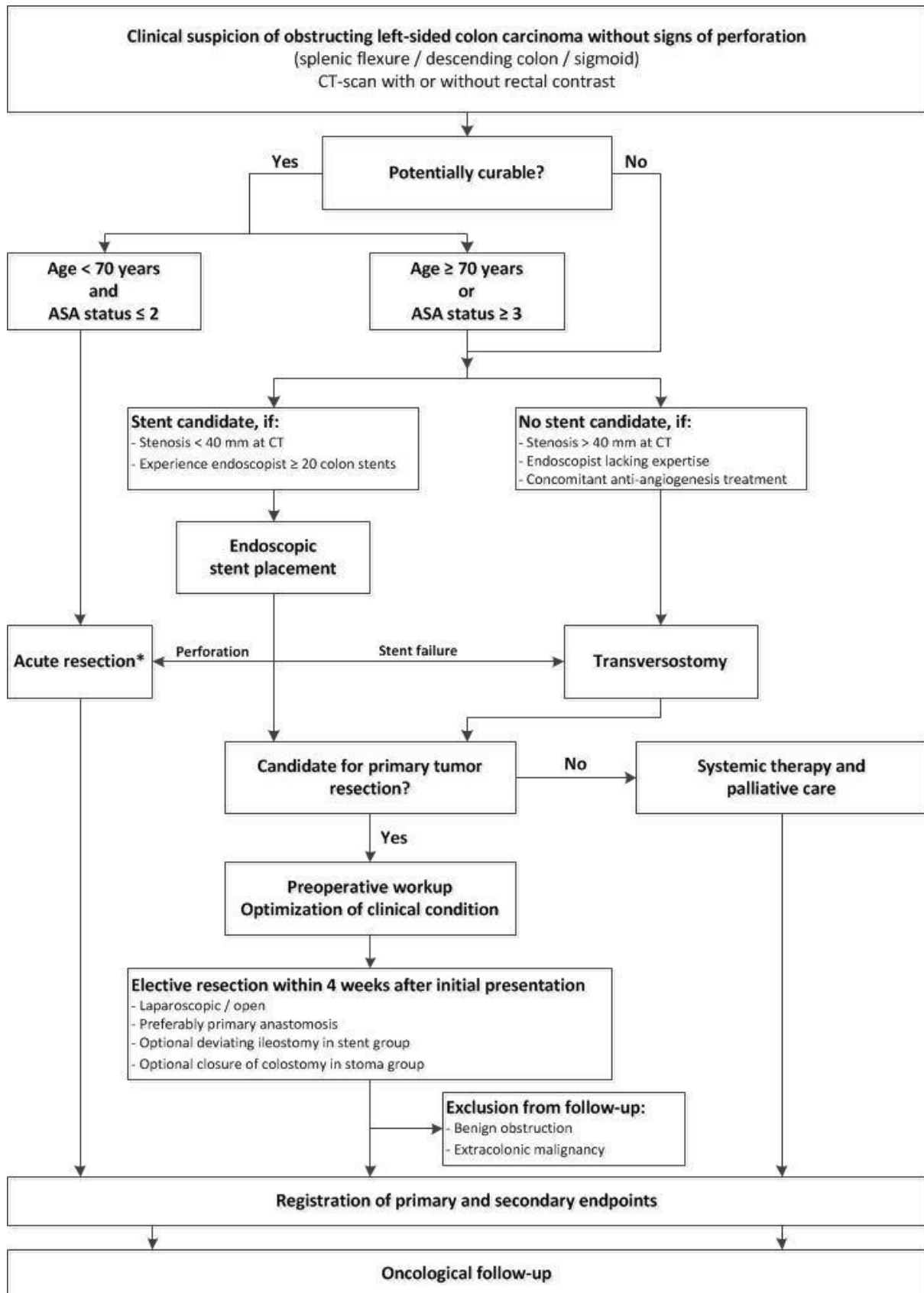

* Except the patients who have an indication for neoadjuvant therapy because of locally advanced disease. They should be treated by decompressing colostomy

Clinical decision guideline for the treatment of obstructing left-sided colon cancer

P44

Long-term survival update of the phase 2 trial evaluating short-course radiotherapy followed by neoadjuvant bevacizumab, capecitabine, and oxaliplatin and subsequent radical surgical treatment in primary stage IV rectal cancer.

C. Bisschop¹, T.H. Van Dijk¹, J.C. Beukema¹, R.L.H. Jansen², H. Gelderblom³, K.P. De Jong¹, H.J.T. Rutten⁴, C.J.H. Van de Velde³, T. Wiggers¹, K. Havenga¹, G.A.P. Hospers¹

¹University Medical Center Groningen, GRONINGEN, Netherlands

²Maastricht University Medical Center, MAASTRICHT, Netherlands

³Leiden University Medical Center, LEIDEN, Netherlands

⁴Catharina Hospital, EINDHOVEN, Netherlands

Objectives: Rectal cancer with synchronous metastases causes a treatment dilemma: which tumor location poses the biggest threat and should be targeted first? In a Dutch phase 2 trial, conducted between 2006 and 2010, short-course radiotherapy followed by chemotherapy as neoadjuvant treatment and subsequent radical surgical treatment of primary tumor and metastatic sites was evaluated. In 36 of 50 patients a radical surgical treatment could be performed after neoadjuvant treatment. Two-year survival rate was 80%. The aim of this update of the study was to determine long-term survival and recurrence of disease.

Methods: Patients were eligible for this multicenter study if they had a histologically confirmed diagnosis of rectal adenocarcinoma with potentially resectable or ablatable metastases in liver or lungs. The treatment schedule in the phase 2 trial consisted of pelvic radiotherapy (5 x 5 Gy), followed by six cycles of bevacizumab (7.5 mg/kg, day 1), oxaliplatin (130 mg/m², day 1), and capecitabine (1000 mg/m² twice daily, days 1-14), and surgical treatment 6-8 weeks after the last bevacizumab dose. Surgical procedure was at the surgeon's discretion. Liver metastasis could be treated by partial liver resection or radiofrequency ablation (RFA). Follow-up data was collected for all patients enrolled in the phase 2 trial. Overall and recurrence-free survival were calculated using the Kaplan-Meier method. Subgroups were compared using a long-rank test.

Results: Follow-up data were available for all 50 patients that started in the trial. Median follow-up time was 8.1 years (range 6.0 – 9.8 years). Median overall survival in the intent-to-treat population was 3.8 years (range 0.5 – 9.4 years). In patients in whom a radical surgical resection (R0) could be achieved overall survival was significantly better (4.4 vs. 2.8 years). Five-year survival rate was 38.0%. After a median follow-up time of 8.1 years, 16 patients (32.0%) were still alive and 14 of them were disease-free. Forty-three out of 50 patients (86.0%) had a recurrence of disease during follow-up. Two local and 42 distant recurrences occurred in 43 patients. From the 36 patients that received radical treatment, 29 (80.6%) had a recurrence of disease. Median time to recurrence of these patients was 7 months. Patient with a complete or near-complete pathological response following neoadjuvant treatment had a significantly better recurrence-free survival (16 vs. 6 months).

Conclusion: Long-term survival can be achieved in patients with primary metastatic rectal cancer after neoadjuvant radio- and chemotherapy. Despite a high number of recurrences, nearly a third of the patients were alive after a median follow-up time of 8.1 years.

P45

Benchmarking recent national practice in rectal cancer treatment with landmark randomised controlled trials.

W.A.A. Borstlap¹, D.S.R.G. Dutch Snapshot Research Group², C.L. Deijen³, M. Den Dulk⁴, J. Bonjer⁵, C.J.H. Van de Velde⁶, W.A. Bemelman¹, P.J. Tanis¹

¹Academic Medical Center, AMSTERDAM, Netherlands

²Academic medical center, AMSTERDAM, Netherlands

³VU Medical Centre, AMSTERDAM, Netherlands

⁴Maastricht University Medical Center, MAASTRICHT, Netherlands

⁵VU University Medical Center, AMSTERDAM, Netherlands

⁶Leiden University Medical Center, LEIDEN, Netherlands

Introduction: A Snapshot study design eliminates changes in treatment and outcome over time. This population based Snapshot study aimed to determine current practice and outcome of rectal cancer treatment, with published landmark randomised controlled trials (RCTs) as a benchmark.

Methods: In this collaborative research project, the dataset of the Dutch Surgical Colorectal Audit (DSCA) was extended with additional treatment and long-term outcome data (Snapshot cohort). All registered patients who underwent resection for rectal cancer in 2011 were eligible. Baseline characteristics and outcome were being evaluated against the results of the Dutch TME trial and the COLOR II trial from which the original datasets were obtained.

Results: A total of 71 hospitals participated, and data were completed for 2102 out of the potential 2633 patients (79.8%). Median follow-up was 41 (IQR 25-47) months. Overall circumferential resection margin (CRM) involvement was 9.3% in the Snapshot cohort and 18.9% in the Dutch TME trial. CRM positivity after laparoscopic resection was 7.8% in the Snapshot, and 9.5% in the COLOR II trial. Three-year overall local recurrence rate in the Snapshot was 5.9%, with a disease free survival of 76.3%, and overall survival of 79.5%. Benchmarking with the RCTs revealed an overall favourable long-term outcome of the Snapshot cohort.

Conclusion: This study showed that current rectal cancer care in a large unselected Dutch population is of high level, with less positive CRM since the TME trial and oncological safe implementation of minimally invasive rectal cancer surgery after the COLOR II trial.

P46

Anastomotic leak and chronic sinus following low anterior resection. Incidence, predisposing factors and treatment in a population based cohort.

W.A.A. Borstlap¹, D.S.R.G. Dutch Snapshot Research Group², W.A. Bemelman¹, P.J. Tanis¹

¹Academic Medical Center, AMSTERDAM, Netherlands

²Academic medical center, AMSTERDAM, Netherlands

Introduction

A Snapshot analysis was performed to assess anastomotic leak and chronic sinus rate on a population based level and to identify independent risk factors that are associated with anastomotic leak following low anterior resection.

Methods

In this multi-centre, resident led collaborative research, the dataset of the Dutch Surgical Colorectal Audit (DSCA) was extended with additional treatment and long term outcome data (Snapshot cohort). All registered patients who underwent resection for rectal cancer in 2011 were eligible. Only patients that underwent a low anterior resection were included in present analysis.

Results

A total of 71 out of the potential 94 hospitals participated. From the 2095 registered patients, 998 underwent a low anterior resection and were included in present analysis. Median follow-up was 41 (IQR 25-47) months. Anastomotic leak and chronic sinus rate were 20.1% and 8.6% respectively. In total, 42% of the anastomotic leaks developed into a chronic sinus. Independent predictors for an increased risk on anastomotic leak were neoadjuvant therapy and a distal rectal carcinoma with corresponding odds ratios of (OR) 2.85 (95% confidence interval (CI) 1.00-8.11) and 1.88 (95% CI 1.02-3.46) respectively.

Conclusion

This population based cohort shows a high percentage of anastomotic leak, a substantial amount of anastomotic leaks that develop into a chronic sinus and neoadjuvant therapy to be an independent predictor of an increased late rate. The chronic sinus is a clinical problem that should be brought under the attention in order to improve long term outcomes following anastomotic leak.

P48

Locally advanced colon cancer: peritoneal penetration as a predictive factor for peritoneal metastases.

C.E.L. Klaver¹, N.C.M. Van Huijgevoort¹, A. De Buck van Overstraeten², A.M. Wolthuis², P.J. Tanis¹, J.D.W. Van der Bilt², X. Sagaert², A. D'Hoore²

¹Academic Medical Center, AMSTERDAM, Netherlands

²UZ Leuven, LEUVEN, Belgium

Objectives: T4 stage of colorectal cancer (CRC) is a risk factor for developing peritoneal carcinomatosis (PC). However, when taken all T4 colorectal cancers together, reported risks of developing PC varies widely from 8-50%. Besides mode of detection (imaging, relaparotomy, autopsy), this might be explained by the various definitions of T4. As a consequence, heterogeneity of included tumours within T4 cohorts exists, especially with respect to local peritoneal involvement. Peritoneal involvement of CRC can be peritoneal hyperplastic or mesothelial inflammatory reaction or true tumour penetration. The aim was to assess the association between the extent of peritoneal involvement and risk of developing peritoneal carcinomatosis (PC).

Methods: All patients who underwent resection of pT4 CRC in the UZ Leuven between Jan 2010 and Jul 2013 were eligible. Pathologists systematically divided peritoneal involvement (pT4) into two categories: peritoneal reaction with tumour within 1 mm of the peritoneal surface and peritoneal penetration.

Results: Information on the extent of peritoneal involvement was available in 159 of 183 eligible pT4 CRC patients: peritoneal reaction with tumour < 1 mm was present in 43 (27%) and peritoneal penetration in 116 (73%). Overall, 29 (18%) patients were synchronously diagnosed with PC. Another 30 of the remaining 130 patients (23%) developed metachronous PC. Peritoneal penetration (OR 2.86 95%CI 1.26-6.51; p=0.012) was associated with any PC in univariable analysis. In multivariable regression analysis, only lymph node involvement was significantly associated with PC.

Conclusion: Histological confirmation of true peritoneal penetration seems to be able to define a high risk subset of T4 tumours regarding development of PC, but larger studies are needed to confirm this observation. In current TNM classification systems, the evaluation of the exact peritoneal involvement of the tumour is not incorporated. With evolving treatment strategies that aim to treat PC at an earlier or even preventive setting, identification of high risk patients becomes of more clinical importance.

P49

Laparoscopic surgery for T4 colon cancer; a systematic review and meta-analysis.

C.E.L. Klaver, T. Kappen, W.A. Bemelman, P.J. Tanis

Academic Medical Center, AMSTERDAM, Netherlands

Background: In T4 colon cancer, laparoscopic surgery might jeopardize radicality of resection. T4 stage is therefore still assumed to be a relative contraindication for laparoscopic surgery. Considering the increasing expertise with laparoscopic colectomies, this assumption might be outdated. The aim of this review was to evaluate postoperative complications and oncological outcomes after laparoscopic surgery for T4 colon cancer and to compare it to open surgery.

Method: A systematic search of literature was performed the 1st of August 2016. Studies reporting on R0 resection rates and/or long term oncological outcomes after laparoscopic surgery for T4 colon cancer were included. Outcome data were pooled and meta-analyses comparing laparoscopic with open surgery were performed.

Results: In total 8 studies were included, consisting of 6 comparative and 2 non-comparative observational cohort studies, all published between 2010 and 2015. In patients that underwent laparoscopic surgery for T4 colon cancer, the pooled proportion that developed a postoperative complication was 0.23 (95% CI: 0.18-0.28) and the pooled R0 resection rate was 0.91 (95% CI: 0.83-0.95). Pooled 3y DFS was 70% (95%CI 61-78%). If compared to open surgery, no significant differences were found.

Conclusion: Similar outcomes for laparoscopic and open surgery for T4 colon cancer are reported regarding postoperative complications, R0 resection rate and long term oncological outcomes. However, it remains unclear how to interpret these outcomes due to substantial allocation bias. Laparoscopic surgery for T4 colon cancer should be applied with caution.

P50

Colorectal cancer at high risk of peritoneal carcinomatosis; long term outcome of a pilot study on prophylactic HIPEC and future perspectives.

C.E.L. Klaver, W.A. Bemelman, P.J. Tanis, J. Crezee, D.A.M. Sloothaak, C.J.A. Punt, R. Stam

Academic Medical Center, AMSTERDAM, Netherlands

Objective: The peritoneum is the third most common site of recurrence in colorectal cancer (CRC). The difficulties with early detection of peritoneal carcinomatosis (PC), together with the restrictions of curative intent treatment options at a clinical overt stage, necessitate development of new therapeutic approaches for CRC patients at high risk of PC. Prophylactic HIPEC is currently investigated. In preparation of a randomized trial determining the effectiveness of adjuvant HIPEC, a single centre pilot study of ten 'high risk' patients was performed in 2011 in order to determine the feasibility of adjuvant laparoscopic HIPEC in a short stay setting. The aim of this study was to present long term oncological outcomes of this pilot study.

Methods: Between January 2011 and July 2012, ten patients were included in a single-centre pilot study, with a diagnosis of adenocarcinoma of the colon and proximal rectum, and at least one of the following risk factors for PC: pT4, (resected) local peritoneal nodules in the close proximity of the primary tumour, primary tumour presenting with obstruction and/or perforation, positive cytology in peritoneal lavage, ovarian metastasis or omental metastasis. All patients underwent laparoscopic HIPEC (using mitomycin-C) within 4-8 weeks after resection of the primary tumour. For present analysis, data on long term oncological outcomes were retrospectively collected.

Results: The median follow up was 54 months (range 49-63). All patients were alive at last date of follow-up and none of them has developed PC. Two patients had disease recurrence, consisting of pulmonary metastases in both patients.

Conclusion: In the present study the long term oncological outcomes of the ten patients included in a pilot study on adjuvant HIPEC were updated. Currently, none of the patients has developed PC. This result is in line with two other pilot studies, which is a promising observation. However, the outcomes of the Dutch randomized COLOPEC trial and similar trials that are currently recruiting worldwide should be awaited for definite conclusions on the effectiveness of adjuvant HIPEC.

P51

Abdominal infectious complications after resection for T4M0 colon cancer increase the risk at abdominal disease recurrence.

C.E.L. Klaver¹, K.A.T.G.M. Wasmann¹, H. Van Santvoort², J.H.W. De Wilt³, M. Versteegen³, I. Nagtegaal³, A. De Buck van Overstraeten⁴, A.M. Wolthuis⁴, J.D.W. Van der Bilt⁴, P.J. Tanis¹, A. D'Hoore⁴

¹Academic Medical Center, AMSTERDAM, Netherlands

²St. Antonius Ziekenhuis, NIEUWEGEIN, Netherlands

³Radboud University Medical Center, NIJMEGEN, Netherlands

⁴UZ Leuven, LEUVEN, Belgium

Objectives: Patients with T4 colon cancer are at risk for developing abdominal recurrence, consisting of peritoneal metastases or local recurrence. Despite the prevalence and impact on prognosis, the pathophysiological mechanisms of developing abdominal recurrence remain unclear. Potentially, infection-based immunologic pathways create a favorable environment for colon cancer cell dissemination in the abdominal cavity. We therefore hypothesize that patients who develop a postoperative abdominal infectious complication after a resection for T4 colon cancer, have an increased risk of abdominal recurrence.

Methods: All consecutive patients who underwent resection of T4N0-2M0 colon cancer in the UZ Leuven, the St. Antonius Hospital, and the Radboud UMC between January 2000 and July 2013 were eligible. Patients were categorized into those with and without an abdominal infectious complication, defined as all postoperative abdominal infections (i.e. anastomotic leakage, abscess, and wound infection) occurring within 30 days postoperatively or during hospital admission. Primary outcome was abdominal recurrence (defined as local recurrence and/or peritoneal metastases) assessed using Kaplan-Meier and Cox regression analyses. Secondary outcome measures were disease free survival (DFS) and overall survival (OS).

Results: In total, 363 pT4N0-2M0 colon cancer patients were included in this study. Median follow-up was 53 months. Of all patients 16% experienced an abdominal infectious complication. The 5-year abdominal recurrence rate was 48% for patients that experienced an abdominal infectious complication, compared to 27% in patients without abdominal infectious complications. In a multivariate Cox regression analysis abdominal infectious complications were significantly associated with abdominal recurrences (HR: 2.396; 95%CI:1.425-4.029; $p=0.001$). Abdominal infectious complications did also negatively impact DFS (HR:1.969; 95%CI:1.343-2.3886; $p=0.001$), but this finding did not translate into worse OS for patients with abdominal infectious complications (HR: 1.464;95%CI:0.882-2.432; $p=0.141$). Other significant risk factors for abdominal recurrence were right-sided tumours (HR: 1.695; 95%CI:1.115-2.576; $p=0.014$) and N2-stage (HR: 2.573; 95%CI:1.571-4.214; $p=0.000$).

Conclusion: Abdominal infectious complications following resection of a T4M0 colon cancer are associated with the development of abdominal disease recurrence and worse DFS. This findings might support the hypothesis that infection-based immunologic pathways play a role in colon cancer cell dissemination.

P53

Too Frail for Surgery? Validity of a frailty index in Major Colorectal Surgery

G. Crozier Shaw, W.P. Joyce

Galway Clinic, GALWAY, Ireland

Objectives

Frailty is defined as increased vulnerability from the accumulation of morbidities in multiple organ systems. Recent evidence suggests objective measures of frailty may better predict outcomes in elderly patients compared to chronological age. The authors aim to demonstrate the validity of a frailty index in predicting negative post-operative outcomes in patients undergoing major colorectal surgery.

Methods

A retrospective review of a prospective colorectal database over a 14 year period by a single surgeon was studied. Patients under the age 65 were excluded, with 205 patients eligible for study. Patients underwent resections for both benign and malignant colorectal disease.

Patients were assessed using a validated National Surgical Quality Improvement Database (NSQIP) Frailty Index (FI). A total of 11 variables were included. An FI score was calculated by applying a score of 1 for each variable and dividing by 11. A score of >0.25 was diagnostic of frailty. Patients were compared as frail or not frail. Endpoints measured were ICU stay, post-op complications and 30 day post-op mortality. FI endpoints were compared to ASA grade and P-Possum CR mortality index.

Results

Of 205 eligible patients, 43 (21%) were frail and 162 (79%) were not frail. Patients classified as frail had an ASA grade ≥ 3 (21%) while non-frail patients had an ASA grade ≤ 2 (79%).

3 (7%) frail patients required ICU stay compared to 10 (6%) of non-frail patients ($p=NS$). ICU admissions in Frail versus Non-Frail patients had mean P-Possum mortality of 48% versus 11.4%.

17 (40%) of frail and 42 (26%) of non-frail patients had post-op complications ($p<0.05$). Complications in Frail versus Non-Frail patients had a mean P-Possum mortality of 12.5% versus 6.12%.

2 (5%) of frail patients and 4 (2.5%) of non-frail patients died within 30 days of surgery ($p=NS$). Mortality at 30 days in Frail patients versus Non-Frail patients had a mean P-Possum mortality of 43% versus 16.6%.

Conclusions

These data demonstrate that frailty is a reliable predictor of poor outcomes and mortality in patients undergoing major colorectal surgery for both benign and malignant disease. This is validated by similar trends noted when applying ASA grade and P-Possum CR Mortality to both frail and non-frail groups. This has great significance in dealing with an ever increasingly aged population requiring major surgery for benign and malignant colorectal disease.

Disclosures: N/A

P54

Screening and systematic follow-up for cardiopulmonary comorbidity in patients having surgery for colorectal cancer. A randomized feasibility study

H.B. Rahr, C.G. Kryh, I.S. Vid Strey Thomsen, E. Ejlersen, A. Sejr Knudsen, S. Kristensen, H.T. Hougaard

Vejle Hospital, VEJLE, Denmark

Background

More than one third of patients with colorectal cancer (CRC) suffer from comorbidity such as heart and lung diseases. This comorbidity markedly impairs survival after surgical treatment owing to increased mortality within the first weeks to months after surgery, and this increased mortality is related to medical complications such as heart and lung complications. Since the operation itself constitutes a severe challenge to the patient's cardiopulmonary system, this study aims to elucidate whether a more systematic perioperative management and follow-up of colorectal cancer patients with cardiopulmonary comorbidity may improve their outcome as measured by complications, hospitalization times, and survival within the first year.

Methods

All patients scheduled for elective surgical treatment of CRC at Vejle Hospital are screened by a study nurse for cardiopulmonary comorbidity to determine their eligibility for inclusion. If they fulfil inclusion criteria, they are seen preoperatively by a cardiologist and/or a pulmonary physician and undergo echocardiography and/or spirometry. Included patients are randomized postoperatively to either standard follow-up alone ("standard" group) or standard follow-up supplemented with structured medical management and follow-up ("intervention" group).

Patients in the intervention group are examined on the 4th or 5th postoperative day by an experienced physician from the Department of Internal Medicine. Furthermore, the intervention group is followed up at outpatient visits 1 and 3 months postoperatively. The 1-month visit includes a cardiology visit with echocardiography and ECG, and a pulmonary medicine visit with spirometry. The 3-month visit includes only a pulmonary medicine visit with spirometry.

Mortality, cardiopulmonary complications, hospitalization time and treatment changes induced by the structured follow-up will be recorded as outcome measures for the intervention. The study is powered to obtain more accurate estimates of the present-day postoperative mortality in the two groups, hopefully forming a basis for a future large-scale multicenter trial.

Results

The study is expected to close by the end of October, 2016, after inclusion of 180 patients. We hope to be able to present the first results at the EMCCC in December.

Conclusions

If a structured medical follow-up can be shown to improve outcome and survival after CRC surgery, this intervention may easily be disseminated worldwide and benefit the 30-40 % of patients with comorbidity undergoing CRC surgery.

P55

Preoperative chemoradiotherapy for elderly patients with locally advanced rectal cancer - a real world outcome study

J.S. Kim¹, Y.N. Choi¹, J.H. Kim², J.W. Kim², K.W. Lee², H.K. Oh², D.W. Kim¹, S.B. Kang², K.H. Lee¹

¹Seoul National University Bundang Hospital, SEONGNAM, South Korea

²Seoul National University Bundang Hospital, SEONGNAM, South Korea

Objectives: Preoperative chemoradiotherapy (CRT) has been established as a standard treatment for locally advanced rectal cancer. It is unclear whether preoperative CRT is truly beneficial in the elderly patients. Our aim was to assess the impact of age on the treatment tolerance and clinical outcomes.

Methods: We retrospectively analyzed 160 consecutive patients with clinical stage T3-4, and/or lymph node positive tumors who received preoperative CRT from May 2003 to December 2010 at a single hospital. Treatment tolerance and outcomes were compared between patients ≥ 70 years (N = 56) and < 70 years (N = 104).

Results: There was no disparity in the achievement of prescribed radiation dose and dose reduction of chemotherapy between two groups. Pathologic complete response rate (15.6% vs. 16.0%) and sphincter preservation rate (91.1% vs. 95.0%; $P = 0.459$) were not significantly different. The 3-year DFS of older vs. younger patients was 77.8% vs. 92.3% and 5-year DFS was 60.0% vs. 78.6%, respectively ($P = 0.023$). In multivariable analysis, age was significantly associated with DFS ($P = 0.033$) but comorbidities was not ($P = 0.092$). However, both age (HR, 2.331; $P = 0.028$) and comorbidities (HR, 2.772; $P = 0.031$) were significantly associated with OS as well as clinical stage. Anemia was the only adverse effect more prominent in older patients.

Conclusion: Older patients showed non-inferior compliance and equivalent pathologic complete response rates without an increased incidence of treatment complications with preoperative CRT. More comprehensive consideration than age alone is warranted in the decision of applying preoperative CRT to elderly patients with rectal cancer.

P56

Risk factors of post-operative mortality in patients aged 80 years or older with colorectal cancer

Y.J Chern

Chang Gung Memorial Hospital, TAIPEI, Taiwan

Purpose:

In Taiwan, there is an increasing trend in curative treatment for elderly patients with colorectal cancer. Since operation is the main treatment strategy for colorectal cancer, we analyzed the clinical information about the patients aged 80 years or older who had undergone operations for colorectal cancer to evaluate the risk factors of post-operative mortality.

Materials and Methods:

All study participants, aged more than 80 years, were recruited from patients who had received major operations for colorectal cancer at Linkou Chang Gung Memorial Hospital between March 1996 and September 2009. The operation type was tumor resection either by colectomy or proctectomy. Clinical data, including comorbidity, pre-operative laboratory data, and cancer information, were collected to identify the significant risk factors associated with the post-operativemortality.

Results:

A total of 929 patients were enrolled during the study period. The average age was 83.5 (± 3.5) years old. The post-operative mortality rate was 4.1%. Our result showed comorbidity with liver cirrhosis and pulmonary diseases, body mass index, pre-operative albumin level, laboratory examination for liver and renal function, emergent operation and metastatic status were significantly correlated with post-operative mortality.

Conclusion:

Since the increasing proportion of patients older than 80-year-old receiving operations for colorectal cancer, evaluation of the patients' pre-operative clinical conditions is important to minimize the risk of post-operative mortality. This study showed that several risk factors, including comorbidity with liver cirrhosis and pulmonary diseases, pre-operative poor nutrition status, renal function and liver function, emergent operation and metastatic status, should be put into consideration before operation for those patients with CRC aged over 80-year-old.

P57

Completeness of Pathology Reports in Stage II Colorectal Cancer

S. Buettner, Z.S. Lalmahomed, R.R.J. Coebergh van den Braak, B.E. Hansen, M. Doukas, J.N.M. IJzermans

Erasmus MC - University Medical Center, ROTTERDAM, Netherlands

Introduction: The completeness of the pathological examination of resected colon cancer specimens is important for further clinical management. We reviewed the pathological reports of 356 patients regarding the five factors that are used to identify high-risk stage II colon cancers (pT-stage, tumor differentiation grade, lymphovascular invasion (LVI), tumor perforation and, lymph node metastasis (N) status) and their impact on overall survival (OS). High-risk stage II patients are thought to benefit from adjuvant chemotherapy.

Methods: All patients with stage II colon cancer who were included in the first five years of the MATCH study (July 1 2007 –July 1 2012) were selected (n=356). Differences with groups were assessed using the Kruskal-Wallis test for continuous variables and the Pearson Chi-square test for categorical variables. Survival was estimated using the Kaplan Meier method. The hazard ratios of relevant risk factors were calculated using Cox Proportional Hazards.

Results: In 69.1% of the pathology reports, the desired information on one or more risk factors was considered incomplete (61.2% 1 factor, 7.9% 2 factors). Just over half (n=193, 54.2%) of the patients were male. The median age was 71 years (interquartile range[IQR] 64-79 years). Half of the patients underwent laparoscopic surgery (n=174, 49.0%) and most patients underwent a right- (n=172, 49.0%) or left-sided hemicolectomy (n=169, 48.1%). The majority of patients had a T3 (n=324, 91.0%), whereas a small minority had a T4 tumor (n=32, 9.0%). Of our 356 patients, 312 (87.6 %) patients did not have lymph node metastases and had 10 nodes or more, while 44 (12.4%) did not have the required minimum of 10 nodes. Over three quarters of the patients had a moderately differentiated tumor (n=298, 83.9%). Only a small subgroup of patients (n=21, 5.9%) received adjuvant therapy. Between the Nx vs. N0 group a significant difference was observed in median age (71 vs. 75 years, p=0.037). T4 patients vs. T3 patients received adjuvant chemotherapy (37.5% vs. 2.8%, p<0.001) more often, and had an unknown (not reported) differentiation grade (9.4% vs. 1.5%, p=0.021) more frequently. No clinical differences were observed between patients with LVI, without LVI, and patients in whom this factor was not recorded in the pathology report. Median follow-up in our cohort was 72.4 months (IQR 62.8-80.8). The 1-, 3- and 5-year survival was 98.0 %, 89.1, and 80.4% respectively. In multivariable analysis, age (HR: 1.07, 95%CI 1.04-1.10, p<0.001), moderately- (HR: 0.35, 95%CI 0.18-0.70, p=0.003) and well (HR 0.11, 95%CI 0.01-0.89, p=0.038) differentiated tumors were significantly associated with OS. Adjuvant chemotherapy was not significantly associated with OS.

Conclusion: Pathology reports should describe the five high-risk factors in order to enable proper patient selection for further treatment. This study shows that completeness of scoring of high-risk factors should be stressed as chemotherapy may be offered those patients in whom a set of prognostic markers is present. Further research into these prognostic markers is warranted, as a definitive set is still unavailable.

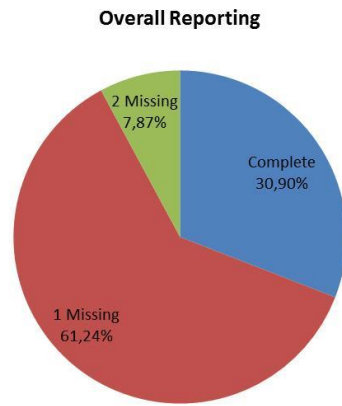

Figure 1. Overall reporting of high-risk factors (N-stage, T-Stage, Lymphovascular Invasion, and Tumor Differentiation) in the pathology report

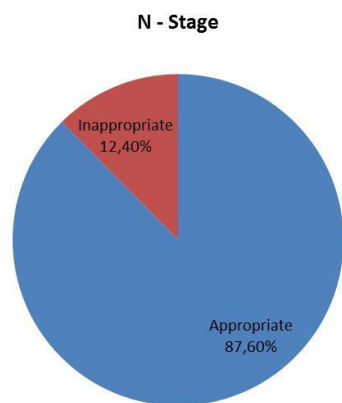

Figure 2. N-Stage Pathology Report Scoring

P58

Total mesorectal excision with water-jet dissection in patients with rectal cancer: surgical and morphological results

L.O. Petrov, D.V. Sidorov, M.V. Lozhkin, A.A. Troitskiy

P. Hertsen Moscow Oncology Research Institute, MOSCOW, Russia

Objectives. The total mesorectal excision TME technique includes mobilization of the rectum under visual control within the mesorectal fascia, along with preservation of the pelvic vegetative nerves. Surgeons across the world traditionally use scissors, coagulators, and, lately, harmonic scalpels for this kind of mobilization. This publication will describe our own initial (the first in Russia) experience of using the ERBEJET2® water-jet dissector during surgical interventions for rectal cancer.

Methods. We used the water-jet dissection technique to obtain tissue specimens in 20 patients with rectal cancer. The mean age of these patients was 56.1 ± 11.2 years (range, 44 – 78). The group consisted of 8 men and 12 women. The T2/T3a tumors were either in the middle part (14 patients) or in the lower portion (6 patients) of the rectum. We also used two reference groups consisting of 20 controls each; the rectum was mobilized in them using a monopolar coagulator and a harmonic scalpel. The study groups were comparable with regard to gender, age, tumor sites and spreading. All surgical interventions were performed by the same team of surgeons. Low anterior resections were performed in all 60 patients. Additionally to the routine morphological examination, we performed microscopy of the circumferential resection margin to assess the intensity and depth of damage to the mesorectal tissue.

Results. The mean duration of the surgical operation was 138 ± 36.1 minutes (range, from 100 to 190). There was no postoperative morbidity and mortality. On morphological examination, the quality of mesorectal excision was found to be good (Grade 3) in all 60 patients. The following data were obtained with regard to depth of tissue damage along the lateral margin of the excised tissue. There was virtually no tissue damage (in the fascia and cellular tissue) in patients in whom the rectum was mobilized by means of water-jet dissection. The worst lateral resection margin damage (as a result of the thermal impact, sometimes including foci of coagulative necrosis) was observed following the use of a monopolar coagulator – 1.7 to 3.0 mm deep. Lateral tissue damage was less pronounced when the

rectum was mobilized with the harmonic scalpel, as compared with the monopolar coagulator. The maximal depth of tissue damage along the lateral resection margin was between 1.0 and 1.5 mm in this group.

Conclusion. Our initial experience in the use of the water-jet dissector in the process of total mesorectal excision indicates that this technique is safe and effective. The absence of lateral thermal tissue damage (primarily the pelvic vegetative nervous system elements) permits use of this type of dissection in the “critical points” of mesorectal excision without any risk of lateral damage.

P59

Tumor response in locally advanced rectal cancer. Experience of multi-agency group 2010-2016

M.V. De Torres¹, B. Losada Vila², I. Juez¹, D. Gutierrez Abad², J.C. Camara³

¹H Universitario Fuenlabrada, MADRID, Spain

²Hospital Universitario de Fuenlabrada, MADRID, Spain

³H Universitario Alcorcon, MADRID, Spain

Objectives:

To review tumor stages and tumor response degrees of patients treated with neoadjuvant chemoradiation. We also desire to know whether response degree influences in the recurrence or disease progression.

Methods:

A retrospective study of 150 patients diagnosed with locally advanced rectal cancer in the last 6 years. Our protocol includes 50 Gy concurrently to 5FU or capecitabine followed by abdominoperineal amputation (ABP) or low anterior resection (RAB). Pathology reports are analyzed and we also perform surveillance(CT,CEA, Ca 19.9) .

Results:

Average age was 67 years (range 37-89 years). According to the patient’s status, 10% died with disease, 78.7% actually have no tumor, 8% live with tumor disease and 1.3% have died unrelated to the tumor. Regarding the type of treatment, 98.7% have finished chemoradiotherapy (CRT) . Following to CRT, 147 patients have been operated (R0 in 96.3%). To define tumor response after CRT we follow Dworak criteria (grades 1--4) in which grade 0 indicates no tumor regression and 4: complete regression. One patient died because of the treatment (hemorrhage) Among 144 patients analyzed after surgery, 30.6% developed a tumor complete response, highlighting that many of them initially were c T3 stage. Another 30.6% developed a grade 3 of response, so we achieved a very important tumor response(grade 3 and 4) in more than 60% of our patients. The median of lymph nodes analysed was 14. Our next step is to test whether these results influence at the time of tumor recurrence. Analyzing rates of progression, among all patients who do not progress, 63.3% were grade 3-4 after CRT,while analysing those patients who have distant progression, most of them(44%) have achieved grade 1--2 after CRT.

Figure 1.Clinical Stage and relation with response tumoral degree. Response tumoral degree Clinical Stage

Conclusions:

Chemoradiation is well tolerated in 100% patients.

Degree of response to CRT is higher than in other studies (30.6% complete response).

In our population it seems that patients with better response to neoadjuvant CRT have a lower risk of recurrence and disease progression.

We need further studies and biomarkers.

		Response tumoral degree					Total
		GR 0	GR1	GR2	GR3	GR4	
Clinical stage	cT2	1	1	3	1	3	9
	cT3	0	21	21	39	36	117
	cT4	0	5	4	4	5	18
Total		1	27	28	44	44	144

P60

Pelvic fractures and radiotherapy treatment planning in rectal cancer

C.J.S. Kronborg¹, J.B. Jørgensen², J.B.B. Petersen², L.H. Iversen², B.G. Pedersen², K-L. G. Spindler²

¹Aarhus University hospital, AARHUS, Denmark

²Aarhus University Hospital, AARHUS, Denmark

Objectives: Pelvic insufficiency fracture (PIF) is a well-known complication to radiotherapy in rectal cancer patients

with a reported incidence up to 12%. Studies describing dose volume relationships are lacking. Radiotherapy techniques have changed from 3D to Intensity modulated radiation therapy (IMRT) or Volumetric modulated arc therapy (VMAT), with little knowledge of dose volume relationships and the effect on pelvic bones. In daily treatment planning there are no validated constraints to the bony structures, and in general, sparing of the bowel cavity and bladder wall are prioritized compared to doses to the pelvic bones. The aim of this study was to analyze dose volume histograms (DVH) and PIFs in patients treated for rectal cancer with neo-adjuvant chemo-radiotherapy, and to compare the bone sparing capacity of VMAT and fixed field IMRT with proton beam therapy while maintaining bowel and bladder dose.

Methods: Consecutive patients formerly treated for rectal cancer, included in a prospective observational study, underwent a 3 year post-operative pelvic MRI and PIFs were identified. This study included all patients treated at a single center with 52Gy (46Gy) in 26 fractions and one who received 45Gy/25F, based on 2-arc VMAT technology with 15 MV (Varian Eclipse planning system). Pelvic bones were retrospectively delineated including separate delineation of the sacral bone and sacroiliac joints (1 cm to each side of the joint) and DVHs were re-calculated. For comparison the Wilcoxon rank-sum test was used. Supplementary two proton therapy plans were performed in the case with the highest V30Gy to the sacroiliac joints. We compared a 2 beam (lateral opposing) and a 3 beam (lateral opposing and PA) technique on Eclipse optimized with Multi Field Optimization (IMPT).

Results: Of 28 patients (19 males, mean age 62 years) PIFs were identified in 9 (32%). Six of these had fractures in multiple locations, including: symphysis (n=4), acetabulum (n=6), iliac bone (near joint) (n=6), sacral bone (alae) (n=8), and sacral bone (midline) (n=2). Dose volume relationships (V45Gy, V30Gy, and V20Gy), mean and max doses of the total pelvis, sacral bone and sacroiliac joints were compared between the patients with and without PIFs. Patients with PIFs had received a significantly higher V30Gy to the sacroiliac joints than patients without detectable fractures (68.5% (60.1-69.2 IQR) vs. 55.3% (54.1-66.6 IQR), $p=0.046$), whereas all other dose volume parameters were comparable. Proton beam plans were compared and significant sparing was demonstrated on all bone parameters, exemplified by 2-arc VMAT vs. the 2 beam opposing technique: V30Gy pelvic bones: 50.3% vs. 39.6%, V30Gy sacral bone: 96% vs. 56.1%, and V30Gy sacroiliac joints: 78.5% vs. 29.5%.

Discussion / Conclusion

In this study we found a high incidence of PIFs three years after radiotherapy correlated to a higher V30Gy for the sacroiliac joints. Proton beam plans offered sparing of pelvic bones while preserving low doses to bowel and bladder. Further optimal planning techniques to avoid the pelvic bones will be discussed, including comparison of fixed field IMRT, 3-arc VMAT planning and proton beam therapy.

P61

Impact of concomitant radiotherapy boost in locally advanced rectal cancer

M.A. Estornell¹, D. Martinez², V. Morillo³, M. Lopez¹, M. Soler¹, J.L. Monroy¹, A.V. Navarro¹, A.M. Soler-Rodriguez¹

¹Hospital Universitario de la Ribera, ALZIRA, Spain

²Hospital Universitario de Valladolid, VALLADOLID, Spain

³Hospital Provincial de Castellon, CASTELLON, Spain

OBJECTIVES AND PURPOSES

The standard preoperative radiation dose for locally advanced rectal cancer (LARC) is 45-50.4 Gy in 25-28 fractions. The aim of this study is to analyze the correlation between escalation radiotherapy dose, pathological complete clinical response (pCR) and downstaging rate or even its relation with other parameters of interest as toxicity, surgical margins, locoregional recurrence-free survival (LRFSD), distant metastasis free survival (DMFS) and overall survival (OS). The efficacy of the dose escalation in terms of pathological tumor response was evaluated as main end-point.

MATERIAL AND METHODS

Between 2000 and 2013, 287 patients were treated with preoperative chemoradiotherapy and surgical resection for LARC in our hospital. 233 patients underwent the standard chemoradiation schedule (median age 67 years; stage III 73.3%, stage IV 1.7%; 41.1% low third rectum; 45-50.4 Gy; 1.8-2 Gy/fraction; four fields technique; 18 MV photons) and 54 patients were treated with simultaneous integrated boost-SIB (median age 66 years; stage III 74.5%, stage IV 1.8%; 21.8 % low third rectum; 45 Gy to the pelvis volume with a 2.17 Gy SIB on the tumor and macroscopical nodes; conformed fields for SIB; 18 MV photons).

RESULTS

Dose escalation radiotherapy treatment reports a benefit in pCR (9.5 % vs 20 % $p=0.029$), tumoral downstaging rate (42.7 % vs 60% $p=0.020$), nodal downstaging rate (62.9% vs 7.7% $p=0.173$) and ypT0 rate (10.3% vs 20% $p=0.049$). Complete microscopical resection increases on integrated boost group (93.4% vs 98% statistically non-significant). In the comparison between both groups by Contingency Table, no statistically significant differences were found on toxicity (G2 27.5% vs 37%; G3 3.1 % vs 9%) or surgical complications (35.7% vs 40%). With a follow up of 181 months, the study reports a statistically significance on distant metastasis free survival (56.1% vs 76.7 % $p=0.036$ Kaplan-Meier Test), and overall survival (21% vs 46.65% $p=0.02$) in the SIB group. Locoregional recurrence-free survival also improves but without statistical significance (88% vs 94.9% Kaplan-Meier method). Tumoral downstaging was considered as an independent factor on DFS (HR 1.914 $p=0.004$ Cox model.)

CONCLUSIONS

Escalation dose radiotherapy group achieved statistical differences in pCR (ypT0 yN0), tumoral downstaging rate, overall survival (OS) and distant metastasis free survival (DMFS). The variable Tumoral downstaging demonstrate a great value as an independent factor on DFS.

P62

Intensity of inflammation and lymphoid follicle density in relation to the invasive properties of colorectal cancer

I. Drike, I. Strumfa, A. Vanags, J. Gardovskis

Riga Stradins University, RIGA, Latvia

OBJECTIVES

The progression of colorectal cancer and patient's survival depends on many factors, including the characteristics of peri- and intra-tumoural inflammation (Klintrup *et al.*, 2005; Roxburgh *et al.*, 2009). Several research groups have suggested that better survival can be expected in patients showing intense lymphoid reaction (Vayrynen *et al.*, 2014). The aim of our study was to evaluate inflammation and lymphoid reaction in colorectal cancer in relation to the manifestations of invasive tumour growth.

METHODS

The study included 556 consecutive retrospective colorectal cancer cases, subjected to radical surgical treatment, microscopic evaluation and statistical analysis. After qualitative assessment of Klintrup-Makinen overall peritumoural inflammation score, the identified groups (no inflammation *versus* mild *versus* moderate *versus* severe inflammation) were redistributed into two classes: low-grade (no/mild inflammation) *versus* high-grade (moderate/severe) inflammation. Lymphoid reaction was assessed quantitatively according to Vayrynen, by density of lymphoid follicles. Descriptive statistics, including calculation of 95% confidence interval (CI) as well as Chi square test was applied. Differences were defined as statistically significant if $p < 0.05$.

RESULTS

The study comprised 556 consecutive retrospective cases of colorectal cancer (2011-2014), including pT3 (277; 49.8% [95% CI: 45.7-53.9]); pT4 (197; 35.4% [31.6-39.5]), pT2 (66; 11.9% [9.4-14.8]) and pT1 (16; 2.9% [1.8-4.6]) carcinomas. Low-grade inflammation was present in 134 (48.4% [42.5-54.2]) pT3 and 125 (63.5% [56.5-69.9]) pT4 cancers while high-grade inflammation was found in 37 (56.1% [44.1-67.4]) pT2; 143 (51.6% [44.1-67.4]) pT3 and 72 (36.5% [30.1-43.5]) pT4 tumours. In cancers characterised by low-grade inflammation, lymphatic invasion was identified in 70.1% [64.6-75.0], intraneural invasion in 35.0% [29.8-40.6], and perineural invasion in 56.8% [51.1-62.3] of cases. In tumours showing high-grade inflammation, lymphatic invasion was seen in 56.8% [50.8-62.7], intraneural invasion in 26.7% [21.7-32.4], and perineural invasion in 42.4% [36.5-48.4] of cases. Chi-square test revealed statistically significant difference between tumours exhibiting low-grade *versus* high-grade inflammation regarding lymphatic ($p=0.001$), perineural ($p=0.001$) and intraneural ($p=0.034$) invasion. Lymphoid follicles were found in 193 (34.7% [30.9-38.8]) cases. The mean lymphoid follicle density was 0.24/mm [0.21-0.26]. High lymphoid follicle density according to Vayrynen criteria ($>0.38/\text{mm}$) was seen in 27 (14.0% [9.8-19.6]) carcinomas, showing lymphatic, intraneural and perineural invasion in 51.8% [33.9-69.3]; 14.8% [5.9-32.5] and 36.0% [20.2-55.5] cases, respectively. Tumours characterised by low density of lymphoid follicles featured lymphatic, intraneural and perineural invasion in 57.8% [50.2-65.1], 25.9% [19.8-33.1] and 46.6% [39.1-54.3] cases, respectively. Chi-square test revealed no statistically significant differences between the frequencies of the manifestations of invasive growth in relation to lymphoid follicle density.

DISCUSSION/CONCLUSION

The manifestations of invasive growth including lymphatic, perineural and intraneural invasion are statistically significantly less frequent in colorectal cancers showing high-grade peritumoural inflammation. There was no significant association with lymphoid follicle density. The trend to less frequent occurrence of pT4 tumours among colorectal carcinomas showing high-grade inflammation tends to reject hypothetical link between the assessed peritumoural inflammation and more advanced local tumour spread causing bowel obstruction. In future studies, the impact of chemoradiotherapy on the peritumoural inflammation should be assessed as well.

P63

Clinicopathological study of GI lymphoma

R. Kudva

Kasturba Medical College, MANIPAL, India

Purpose of the study

Extranodal lymphoma is a well-known entity and is distinct from nodal lymphoma both in terms of treatment strategies and prognosis. It can involve any site but gastrointestinal tract (GIT) is the most common extranodal site involved by lymphoma accounting for 10-15% of all non-Hodgkin lymphoma and 30-40% of all extranodal lymphoma. Although lymphoma can involve any part of the gastrointestinal tract, the most common site is stomach followed by small intestine. The objective of this study is to ascertain the anatomic distribution, histological subtypes, and sites of primary GIT lymphomas diagnosed in the Department of Pathology, Kasturba Medical College, Manipal and to correlate it with the clinical features and outcome.

Description of the study

This study was conducted over a period of 5 years from January 2009 to December 2013. Computerized data base of all the patients, histopathology slides, Immunohistochemistry (IHC) slides and medical records were analysed. A total of 66 cases were identified out of which 5 were secondary GIT lymphoma cases and rest 61 were primary. It

included both resected surgical and endoscopic biopsy specimens. All 61 primary GIT lymphoma cases were reviewed and reclassified according to recent WHO 2008 classification. All the repeat biopsies of a single case were excluded. Tissue sections were routinely processed and stained with haematoxylin and eosin (H&E). IHC was done judiciously depending on the H&E morphology. SPSS software was used to calculate the statistical analysis for all the 61 cases

Results & conclusions

During 5 years, 61 cases of primary GI lymphomas were identified of which 40 cases were males and 21 were females with a male: female ratio of 1.9:1. Majority of primary GIT lymphomas were seen in elderly with a peak incidence in the 7th decade (median age-46years and range of 3-85 years). The most common presenting symptom was abdominal pain (n=47; 77%) followed by vomiting (n=13; 21.3%). The most common site was stomach (n=25;41%) followed by large intestine (n=23; 37.7%) and included caecum, colon and rectum. 12 cases (19.7%) of small intestinal lymphoma were seen and only 1 case out of 61 cases primarily involved anal canal. Intestinal lymphomas were more common in patients with age group ≤ 60 years (72.2%) than in age group > 60 years (27.7%). Also there was predominance of intestinal lymphomas (65%) than gastric lymphomas (35%) in age group ≤ 60 years. The median age for gastric lymphoma was 51 years and for intestinal lymphoma it was lower i.e. 42 years. All cases of primary GI lymphomas were of Non-Hodgkin type and predominantly were B cell lymphomas (n=54; 88.5%). T cell lymphomas were infrequent and constituted only 11.5% (n=7). Diffuse large B cell lymphoma (DLBCL) was the most common subtype accounting for 67.2% of cases (n=41). Second in frequency was low grade marginal zone lymphoma of MALT type (n=9; 14.8%) followed by T-cell lymphoma (n=7; 11.5%). Only one case each of Burkitt lymphoma, DLBCL/Burkitt gray zone lymphoma and Mantle cell lymphoma was found in our study

P64

Predictive role of ABC transporters and stem cell markers in stage III colorectal cancer patients receiving adjuvant FOLFOX chemotherapy

E.U.N. Shin¹, M.L. Kim¹, S.H. Han¹, H.S. Lee¹, B.H. Kim², H.K. Oh¹, D.W. Kim³, S.B. Kang¹, K.W. Lee¹, J.W. Kim¹

¹Seoul National University Bundang Hospital, SEONGNAM, South Korea

²Kyung Hee University College of Medicine and Hospital, SEOUL, South Korea

³Seoul National University Bundang Hospital, SEONGNAM, South Korea

Objectives There are emerging evidences that chemoresistance results from selective resistance of a cell subpopulation from the tumor that has distinctively molecular and phenotypic feature so called cancer stem cell. Upregulation of ATP-binding cassette (ABC) transporters has been considered as a mechanism that cancer stem cell shows exhibiting a high degree of chemoresistance. The present study aimed to investigate the association of pretherapeutic expression of cancer stem cell markers and ABC transporters and chemoresponse in stage III colorectal cancer (CRC). **Methods** The immunohistochemical expression of 3 cancer stem cell markers (SOX2, LGR5 and ALDH1) and 3 ABC transporters (ABCC2, ABCC3 and ABCG2) was determined in CRC tissues from 165 stage III CRC patients treated with 5-fluorouracil/leucovorin plus oxaliplatin (FOLFOX) regimen following curative resection. The relationship between expression of the proteins and patients' prognosis was analyzed. Expression of ABCC2 and SOX2 was also evaluated in consecutive CRC tissues from 342 patients. **Results** ABCC2 expression was significantly associated with ABCC3 ($p=0.347$, $p<0.001$) and LGR5 ($p=0.354$, $p<0.001$) expression and there was interrelationship between ABCC3 and SOX2 expression ($p=0.192$, $p=0.014$). A significant increase in disease free survival (DFS) was observed in ABCC2, ABCG2, and SOX2 positive CRC cases ($p=0.001$, $p=0.001$, $p=0.008$, respectively). ABCG2 and SOX2 expression was associated with favorable overall survival (OS) ($p=0.005$, $p=0.033$, respectively). In multivariate cox regression analysis for DFS, ABCC2 and SOX2 expression remained as independent prognostic factors (OR=10.25, 95%CI=1.245-6.648, $p=0.013$; OR=7.029, 95%CI=1.184-5.540, $p=0.017$, respectively). Also, ABCG2 was found to be independent prognostic factor for prolonged OS (OR=8.0, 95%CI=2.235-20.860, $p=0.001$). Expression of ABCC2 and SOX2 showed no statistically significant relation with prognosis in consecutive CRC cases. **Conclusion** Expression of stem cell markers and ABC transporters has interrelationship. ABCC2, ABCG2 and SOX2 are associated with prognosis in CRC patients treated with postoperative adjuvant FOLFOX chemotherapy, and may serve as a potential indicator to predict FOLFOX chemosensitivity.

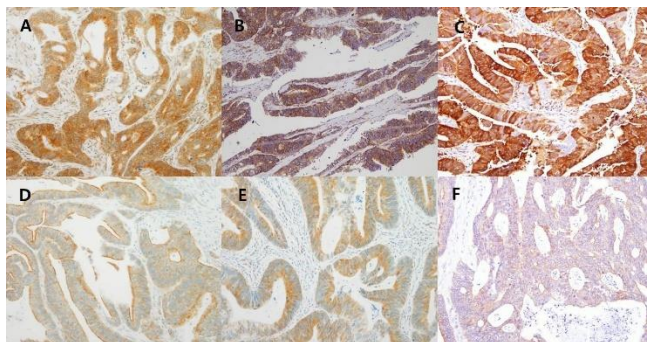

Figure 1. Immunohistochemical expression of stem cell markers and ABC transporters. A. SOX2 B. LGR5 C. ALDH1

D. ABCC2 E. ABCC3 F. ABCG2 (original magni

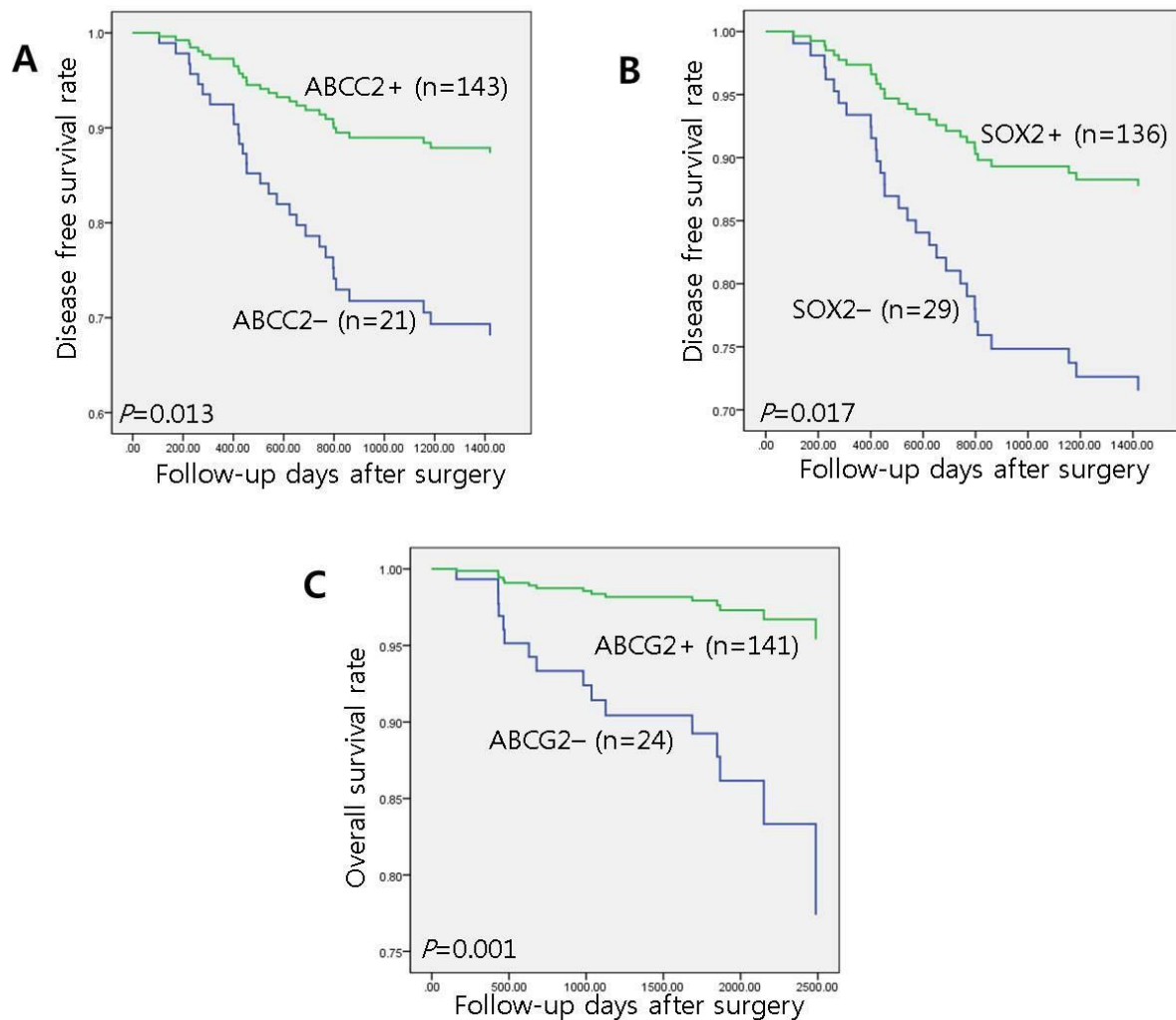

Figure 2. A. Cox regression disease free survival curve according to ABCC2 B. Cox regression disease free survival curve according to SOX2 C. Cox regr

P65

Is the 1 mm resection margin in colon cancer resections a predictor for oncological outcome?

C.A. Bertelsen¹, J. Kleif¹, P. Ingeholm², B. Bols², A.U. Neuenschwander¹, J.E.R. Waage¹, B. Kristensen², I. Gögenur³

¹Hillerød University Hospital, HILLERØD, Denmark

²Herlev University Hospital, HERLEV, Denmark

³Zealand University Hospital, KOEGE, Denmark

Objectives

To investigate the value of the present definition of microradical resection margin (> 1 mm from any tumour tissue) as a risk factor for recurrence after stage III colon cancer, and whether the site of R1 resection (at tumour or mesocolic resection margin) have any importance.

Methods

A prospective single-centre study validated to perform state of the art pathology and complete mesocolic resection (CME) i.e. mesocolic plane dissection with central vessel ligation. 186 patients staged as pN1-2 cM0 colon cancer underwent macroradical CME between June 1 2008 and Dec 31 2013 in Hillerød. 30 (R1 group) were considered as R1 based on the pathological assessment. These were divided into the following subgroups:

R1 at tumour resection margin: N=10

Lymph node (LN) metastasis/tumour deposit at mesocolic resection margin to retroperitoneum or at central ligature: N=21 (2 also in subgroup A)

Venous invasion at central ligature (0 mm): N=1. Excluded from the analyses.

Results

Follow-up was up to five years (mean 3.22±0.13). 11 patients (37%) in the R1 group had recurrence compared with

35 (22.4%) in the R0 group. In univariable Cox regression analyses, R1 as defined currently was a risk factor of recurrence with an HR of 2.19 (95% CI: 1.08– 4.42; $p=0.029$). For R1 at tumour and mesocolic resection margin the HR were 2.87 (1.03–8.03; $p=0.044$) and 1.86 (0.83– 4.16, $p=0.13$) respectively.

In the multivariable Cox regression, R1 at tumour resection margin was a significant risk factor with an HR of 4.51 (1.28–15.9; $p=0.019$), while R1 at mesocolic resection margin was not significant (HR 1.47 (0.56–3.89; $p=0.43$)). Significant confounders were pT4 (HR 3.12 (1.50–6.50, $p=0.0024$), perineural invasion (HR 2.24 (1.11–4.50, $p=0.024$)) and lymph node ratio (LN+/LN) (HR 24.3 (3.54–167, $p=0.0012$)). Tumour site and morphology, EMVI, mesocolic resection plane and adjuvant chemotherapy were not significant.

Discussion / Conclusion

The current R1 definition might have more academic than clinical value, as adjuvant chemotherapy is already indicated in these patients. The importance of R0 at the tumour resection margin is shown, but this study shows also that LN+/tumour deposits covered by intact mesocolic fascia seem not to increase the risk of recurrence in stage III colon cancer. No other studies have investigated this, but dissection in the mesocolic plane seems to ensure this positive effect.

Patients now have access to their records through electronic health records without guidance from surgeons or oncologists. The information in pathology reports needs to be based on evidence and to predict outcome and not cause any unnecessary concerns. Similarly medical staff might, without expertise in colorectal cancer treatment, misjudge the predictive value of R1 in the present definition, and their decision making might be biased.

It is important that the surgeons ensure sufficient resection margin around the tumour. If CME is performed, the presence of LN+ close to the mesocolic resection margin seems of less importance for disease free survival. The current definition of R1 needs to be reconsidered. Our result needs to be confirmed by others.

Univariable Cox regression (N=185)	N	HR (95% CI)	p value
Microradicality (current definition)			0.029
R0	156 (84.3%)	1.00	
R1	29 (15.7%)	2.19 (1.08–4.42)	
Microradicality at tumour resection margin			0.044
R0	176 (95.1%)	1.00	
R1	9 (4.9%)	2.87 (1.03–8.03)	
Microradicality at mesocolic resection margin			0.13
R0	164 (88.6%)	1.00	
R1	21 (11.4%)	1.86 (0.83–4.16)	
Multivariable Cox regression (N=183)	N	HR (95% CI)	p value
Microradicality at tumour resection margin			0.019
R0	174 (95.1%)	1.00	
R1	9 (4.9%)	4.51 (1.28–15.9)	
Microradicality at mesocolic resection margin			0.43
R0	162 (88.5%)	1.00	
R1	21 (11.5%)	1.47 (0.56–3.89)	
Tumour site			0.36
Left sided	94 (51.4%)	1.00	
Right sided	89 (48.6%)	0.71 (0.34–1.48)	
pT stage			0.0024
pT1-pT3	122 (66.7%)	1.00	
pT4	61 (33.3%)	3.12 (1.50–6.50)	
Extramural venous invasion			0.16
No	100 (54.6%)	1.00	
Yes	83 (45.4%)	0.60 (0.30–1.22)	
Perineural invasion			0.024
No	151 (82.5%)	1.00	
Yes	32 (17.5%)	2.24 (1.11–4.50)	
Tumour morphology			
Adenocarcinoma	119 (65.0%)	1.00	
Medullary carcinoma	12 (6.6%)	0 –	0.99
Poorly differentiated adenocarcinoma	28 (15.3%)	1.31 (0.60–2.85)	0.49
Mucinous / signet ring cell	24 (13.1%)	0.35 (0.11–1.13)	0.078
Lymph node ratio (LN+/LN) (median (IQR))	0.09 (0.04–0.20)	24.3 (3.54–167)	0.0012
Mesocolic plane			
Mesocolic	152 (83.1%)	1.00	
Intramesocolic	26 (14.2%)	0.89 (0.38–2.10)	0.80
Muscularis propria	5 (2.7%)	0.94 (0.11–8.11)	0.96
Adjuvant chemotherapy			0.75
No	46 (25.1%)	1.00	
Yes	183 (78.9%)	0.87 (0.37–2.05)	

Cox regression analyses: risk of recurrence

P66

Systematic assessment of tumor budding in local and distant metastases of stage IV colorectal cancer patients

A. Blank, S. Burren, I. Zlobec, H. Dawson, A. Lugli

University of Bern, BERN, Switzerland

Objectives

The prognosis of stage IV colorectal cancer (CRC) patients remains poor and biomarkers which facilitate decision-making in management of these patients are still scarce. In primary CRC, tumor budding is a strong predictor of tumor progression and an independent prognostic factor. Up to now, there are no data on tumor budding in distant metastases. The aim of this study is to systematically assess the prognostic value of tumor budding in local and distant metastases and to evaluate its importance in the clinical management of stage IV colorectal cancer patients.

Methods

The cohort included 331 patients with colorectal cancer surgically treated between 2002 and 2013 at the University

Hospital of Bern. 73 patients with complete clinic-pathological data and availability of the primary tumor and corresponding distant metastases were considered for further analyses. Tumor budding was systematically assessed on immunohistochemical staining for pancytokeratin in primary tumors, corresponding distant metastases and lymph node metastases, if available.

Tumor budding was subdivided into intratumoral budding (ITB, tumor buds in the metastasis center), peritumoral budding (PTB, tumor buds at the margin of the metastasis) and overall tumor budding (OTB, tumor buds independent of the location). The tumor bud count was assessed by calculating the mean number of tumor buds in 10 high power fields.

The tumor bud count in the primary tumor was correlated with the number of tumor buds in lymph node and distant metastases. For survival analysis a cut off of 10 tumor buds was applied to subdivide the cohort in tumors with low and high numbers of tumor buds.

Results

The tumor buds number was higher in primary tumors (PTB: 23; ITB: 24; OTB: 33) compared to lymph node (PTB: 13; ITB: 18; OTB: 21) and distant metastases (PTB: 10; ITB: 21; OTB: 22). Significant differences were detected for PTB and OTB between primary tumor and lymph node metastasis (PTB: $p < 0.001$; OTB: 0.008) as well as for primary tumor and distant metastasis (PTB: $p < 0.001$; OTB: 0.007). For ITB there was a significant difference between lymph node and distant metastasis ($p = 0.04$). Additionally a trend towards a worse prognosis in patients with a high OTB number could be observed.

Discussion / Conclusion

Tumor budding is not only present in the primary tumor, but also in lymph node and distant metastases of colorectal cancer. The number of tumor buds significantly decreases from primary tumor to lymph node and distant metastases. Only a trend towards worse prognosis in patients with high numbers of OTB could be detected which could be explained by the small sample size. Nevertheless, the results seem to be promising for analysis in a large and multicentric clinical trial.

P67

Concordance of KRAS-, NRAS- and BRAF-mutation status in paired biopsy and resection specimens of colorectal cancer?

L. Baandrup, H. Pedersen, J. Bonde, T. Plato Hansen

Hvidovre Hospital, HVIDOVRE, Denmark

Objectives: KRAS-, NRAS- and BRAF-mutation analysis is mandatory prior to initiating anti-EGFR therapy in the management of metastatic colorectal cancer as anti-EGFR treatment only benefits patients with wild-type tumors. To accelerate the oncologic treatment decision, mutation analysis on colorectal biopsies could be a substitute to the current analysis on resection specimens if the biopsies are representative for the mutation status of the tumors. To explore this issue, our study evaluated the suitability of biopsies for KRAS-, NRAS- and BRAF analysis by comparing mutation status of paired biopsy and resection specimens in patients with colorectal cancer.

Methods: A total of 234 consecutive endoscopic biopsies of colorectal carcinomas received at the Department of Pathology, Hvidovre Hospital, between March 15th 2015 and April 15th 2016 were evaluated for mutation analysis. Biopsies with mutation status were paired with their matching resection specimen, excluding pT1 tumors, patients receiving neoadjuvant treatment and patients who did not have resection performed at the Department of Surgery, Hvidovre Hospital.

Mutation analysis was performed on formalin-fixed, paraffin-embedded tissue sections, after evaluation by a pathologist selecting relevant tumor areas with $\geq 10\%$ tumor cells for microdissection. Mutation status was analyzed using single nucleotide mutation specific polymerase chain reaction (PCR) followed by Cancer Mutation Array (Genomica, Madrid, Spain) detecting 14 possible KRAS mutations (codons 12, 13, 61, 117 and 146), 5 possible NRAS mutations (codons 12, 61, 117 and 146) and 2 possible BRAF mutations (V600).

Results: Of 234 biopsies, 43 (18%) contained insufficient material for mutation analysis. Among the remaining 191 biopsies, 53% were wild-type. Mutations frequencies were 28% for KRAS, 14% for BRAF and 10% for NRAS. After exclusions, 98 paired specimens sample sets were available. Overall, we observed 70% concordance between biopsy and resection mutation status. The gene specific concordance was 88% for KRAS, 85% for NRAS and 92% for BRAF. Of the discordant pairs, 17 of 29 (58%) had a mutation in the resection specimen but not in the biopsy, 7 of 29 (24%) had mutations detected in the biopsy but not in the resection specimens and finally, 5 of 29 (10%) had different mutations within the same gene ($n=2$) or within different genes ($n=3$).

Discussion / Conclusion: The overall KRAS, NRAS and BRAF concordance between biopsy and resection specimens was 70%. Biopsies most often represent the superficial part of the tumor, and the observed discrepancy may be explained by intratumor heterogeneity and/or assay sensitivity limitations in the analysis of biopsies due to the in general low amount of tissue, difficulty in distinguishing invasive tumor from adenoma and low tumor/non-tumor DNA ratio. Based on our observations, biopsies of colorectal cancer are not suitable for routine mutation analysis. However, in patients not considered candidates for surgical resection, the endoscopic biopsy may be the only material available for mutation testing and awareness of these pitfalls are therefore important. We propose pathology guidelines to standardize the evaluation of endoscopic biopsies from colorectal carcinomas for mutation analysis, with emphasis on the percentage of tumor cells and the quantity of DNA in the specimen.

P70

The impact of specific comorbid diseases: altered treatment and worse overall survival in colorectal cancer patients in Southern Netherlands

A.C. Bos¹, F.N. Van Erning¹, G.J. Liefers², H.J.T. Rutten³, M. Koopman⁴, T. Rozema⁵, V.E.P.P. Lemmens⁶

¹Netherlands Comprehensive Cancer Organisation, UTRECHT, Netherlands

²Leiden University Medical Centre, LEIDEN, Netherlands

³Catharina Hospital, EINDHOVEN, Netherlands

⁴University Medical Center Utrecht, UTRECHT, Netherlands

⁵Verbeeten Institute, TILBURG, Netherlands

⁶Comprehensive Cancer Center (IKNL), EINDHOVEN, Netherlands

Objectives: Colorectal cancer (CRC) patients are likely to have other age-related chronic diseases. Studies on the impact of specific comorbidities on oncological treatment and overall survival (OS) are scarce, although this information is essential for optimal treatment. This study aims to investigate the effect of specific comorbidities on choice of treatment and 5-year OS.

Methods: Population-based data from the Netherlands Cancer Registry (NCR) in the Eindhoven area were used. All patients diagnosed with primary CRC between 1994-2013 were included. Comorbidity was defined as concomitant diseases (including hypertension) present at time of cancer diagnosis. Multivariable regression analyses were performed to assess the influence of comorbidity on the administration of adjuvant chemotherapy among stage III colon cancer patients, neoadjuvant chemoradiation among cT3-cT4 rectal cancer patients and to evaluate the association of comorbidity with OS, adjusting for age, gender and period of diagnosis. Treatment and stage were included for survival analyses. Treatment analyses for rectal cancer included patients diagnosed between 2008-2013, taking changing guidelines into account. The effects of comorbidity were evaluated for each comorbid condition (or combinations of conditions) separately compared to patients without comorbidity. As a sensitivity analysis, all analyses were repeated for the period 2008-2013.

Results: This study included 27586 CRC patients. Sixty percent of patients suffered from comorbid disease; 27% of patients suffered from one comorbid disease, while in 33% of patients, two or more comorbid diseases were present. The most common comorbidities were hypertension (colon 29%; rectum 26%), cardiac disease (colon 24%; rectum 18%), vascular disease (colon 13%; rectum 10%) and previous malignancy (colon 11%; rectum 8%). Psychiatric or geriatric disease (39%, OR 0.3(95%CI 0.12-0.82)), previous malignancy (51%, OR 0.6 (0.33-0.93)), cardiac disease in combination with vascular disease (27%, OR 0.2(0.10-0.46)) or pulmonary disease in combination with cardiac disease (26%, OR 0.3(0.11-0.61)) were associated with less frequent use of adjuvant chemotherapy in colon cancer patients. Previous malignancy (17%, OR 0.3(0.10-0.65)), cardiac disease (22%, OR 0.4(0.22-0.80)) or diabetes mellitus (22%, OR 0.4(0.19-0.80)) were associated with less frequent use of neoadjuvant chemoradiation in rectal cancer patients. Increasing comorbidity was associated with decreased 5-year OS. Psychiatric and geriatric diseases (5-year OS 43%, HR 1.8(1.48-2.31)), previous malignancy in combination with cardiac disease (5-year OS 37%, HR 1.6(1.30-1.96)) or cardiac disease in combination with vascular disease (5-year OS 37%, HR 1.5(1.26-1.80)) had the greatest effect on survival in colon cancer patients, while pulmonary disease in combination with cardiac disease (5-year OS 34%, HR 2.0(1.55-2.64)) or cardiac disease in combination with vascular disease (5-year OS 44%, HR 1.5(1.09-2.03)) had the greatest effect on survival in rectal cancer patients.

Discussion/conclusion: Increasing comorbidity was associated with less frequent use of adjuvant chemotherapy and neoadjuvant chemoradiation and decreased survival. Patients with previous malignancy, psychiatric and geriatric diseases, pulmonary disease and cardiovascular diseases had the greatest effect on choice of treatment and 5-year OS. It is important that healthcare providers remain vigilant for common comorbidities when coordinating care for these patients.

P71

Molecular Early Detection of Colorectal Cancer (MEDOCC) - Improving the identification of residual disease and disease recurrence in stage II colon cancer patients

K.L. Van Rooijen¹, M. Koopman¹, G.R. Vink², H.M. Verkooijen¹, V.E. Velculescu³, J. Phallen³, W.M.U. Van Grevenstein¹, M. De Noo⁴, G.A. Meijer⁵, V.M.H. Coupe⁶, R.J.A. Fijneman⁵

¹University Medical Center Utrecht, UTRECHT, Netherlands

²Netherlands Comprehensive Cancer Organisation, UTRECHT, Netherlands

³Sidney Kimmel Comprehensive Cancer Center, Johns Hopkins University, BALTIMORE, USA

⁴Deventer Hospital, DEVENTER, Netherlands

⁵Netherlands Cancer Institute, Netherlands

⁶VU University Medical Center, AMSTERDAM, Netherlands

Background

In stage II colon cancer (CC) disease recurrence occurs in approximately 20% of patients. Standard clinical and pathological high-risk features are only moderately predictive for recurrence. Before treatment circulating tumor DNA (ctDNA) is detectable in the blood of the majority of cancer patients and appears to be a good biomarker for minimal residual disease (MRD) after surgery. Appearance of ctDNA after treatment has been completed, is in various tumor

types associated with disease recurrence. ctDNA may therefore help to better identify patients at risk of recurrence and clinical research is warranted to demonstrate its prognostic value. In this study we investigate in stage II CC the association of presence of ctDNA with disease recurrence and survival. Secondary objectives include exploration of the association of specific mutations detected in ctDNA with disease free survival (DFS) and a cost-effectiveness analysis of ctDNA as surveillance tool for stage II CC patients after surgery.

Material and methods

The Dutch Cancer Society - Stand Up To Cancer program Molecular Early Detection of Colorectal Cancer (MEDOCC) contains a multicenter prospective observational cohort study that is conducted within the "Prospective Dutch ColoRectal Cancer cohort" (PLCRC). PLCRC collects long term clinical follow up data, patient reported outcomes, tissue and blood of colorectal cancer patients after informed consent. MEDOCC and various other studies make use of the infrastructure of PLCRC.

In MEDOCC ctDNA of stage II CC patients will be analyzed before surgery, after surgery and every 6 months in the following 3 years or until a recurrence is detected. The ctDNA and patient-matched primary tumor will be analyzed for somatic mutations in a panel of more than 60 genes by next generation sequencing approaches. Specific gene mutations can be followed longitudinally using PCR techniques.

The estimated sample size is 850 patients with stage II CC to analyze the primary endpoint of disease free survival (DFS) 3 years after surgery. Overall survival (OS) is a secondary endpoint. Analysis of mutational status in relation to recurrence will be explored and a cost-effectiveness analysis will be performed.

Exclusion criteria are the presence of another malignancy, unresectability of the primary tumor, neoadjuvant therapy and pregnancy.

Discussion

This study will be conducted to establish the prognostic role of ctDNA in stage II CC. When associations between ctDNA and (lack of) disease recurrence are demonstrated, the next step will be to investigate the use of ctDNA for stratification of patients for adjuvant therapy and to use ctDNA as early biomarker for disease recurrence during follow-up. Hopefully, the results of MEDOCC will help to avoid over- and undertreatment of CC patients.

P73

CT assessment of early response to neoadjuvant therapy in colon cancer

S.R. Rafaelsen¹, C. Dam¹, V. Lund-Rasmussen², J. Pløen¹, A. Jakobsen¹

¹Danish Colorectal Cancer Group South, VEJLE, Denmark

²Rigshospitalet, COPENHAGEN, Denmark

Objectives:

Using multidetector computed tomography, we aimed to assess the early response of neoadjuvant drug therapy for locally advanced colon cancer.

Methods:

Computed tomography with IV contrast was acquired from 67 patients before and after up to three cycles of preoperative treatment. All patients had histologically confirmed colon cancer, a T4 or T3 tumour with extramural invasion ≥ 5 mm and no distant metastases or peritoneal nodules. The patients were treated with oxaliplatin and capecitabine. In addition, those with no mutations in the KRAS, BRAF and PIK3CA genes were also treated with panitumumab. Before and after treatment, we measured the tumour diameter in two different planes, the extension of the extramural tumour invasion, and the number and size of enlarged lymph nodes.

Results:

The mean tumour length was 7.8 cm (95% confidence interval (CI): 5.3-10.4) at baseline and 4.34 cm (95% CI: 4.0-4.9) after treatment. The mean extramural tumour invasion was 10.6 mm (95% CI: 9.5-11.8) at baseline and 5.7 mm (95% CI: 4.7-6.7) after treatment. The mean number of enlarged lymph nodes was 4.1 (95% CI: 3.4-4.9) at baseline and 2.1 (95% CI: 1.4-2.7) after treatment. According to RECIST 1.1, 45% (95% CI: 34-57) of the patients had a response and 55% (95% CI: 43-67) had stable disease. None of the patients showed progressive disease.

Conclusion:

Using MDCT, we report a significant reduction in tumour size, extramural tumour invasion, and number and size of pathological regional lymph nodes following neoadjuvant treatment of locally advanced colon cancer. NEC may induce not only tumour down-sizing, but may bring about a significant prolongation of disease-free survival and eventually improve overall survival. The shown early response to NEC leads to hope for improvement in the outcome of locally advanced colon cancer patients, and clinical follow-up data are warranted.

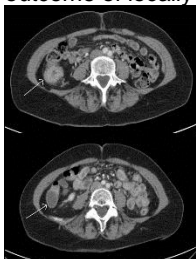

Figure 1. Colon ascendens cancer before and after NEC

P74

Local staging of sigmoid colonic cancer using MRI

S.R. Rafaelsen¹, C. Dam¹, A. Jakobsen¹, J. Lindebjerg²

¹Danish Colorectal Cancer Group South, VEJLE, Denmark

²Danish Colorectal Cancer Center South - Center of Clinical Excellence, VEJLE, Denmark

Objectives:

Locally advanced colon cancer has a poor prognosis. Preoperative chemotherapy is effective in a number of gastrointestinal cancers, including rectal cancer. Preoperative imaging is important to identify patients with locally advanced colon cancer. The aim was to evaluate the diagnostic accuracy of preoperative MRI in identifying locally advanced sigmoid colon cancer and poor prognostic factors correlated with postoperative histopathologic findings. Secondly to evaluate the inter-observer variation of the tumour apparent diffusion coefficient (ADC) values of diffusion-weighted imaging (DWI).

Methods:

The MRI scanning was carried out using a 1.5 Tesla (T) MRI unit. No contrast enhancement was used. Diffusion-weighted imaging was performed perpendicular to the tumour. Five different b values were used, applying diffusion-sensitive gradients; b = 0, b = 200, b = 400, b = 600, and b = 800 s/mm². Regions of interest (ROIs) on the ADC map were drawn manually within the solid tumour part containing slices. The size and position of the ROIs was selected to cover the entire tumour area on a single section containing the largest available tumour area.

The ADC values were blindly compared between two observers. Observer 1: Resident in Radiology and observer 2: Experienced gastrointestinal Radiologist.

A complete postoperative histopathological examination was regarded as the gold standard, none of the patients had any neoadjuvant therapy. Early tumours were defined as T0 to T3ab. T3cd or T4 tumours were classified as advanced tumours.

Results:

The study population included 35 patients with verified colonic cancer. The accuracy for the two radiologist in staging early versus advanced tumours were 94% and 89%. The Inter-observer agreement on tumour staging was very good, K = 0,86 (95% CI:0,67-1,00). For lymph node staging a good agreement was found, K = 0,64 (95% CI:0,39-0,90).

ADC measurement could be performed in all patients with a good inter-observer agreement. All malignant ADC values were < 1.0 x 10⁻³ mm²/s.

Conclusion:

Preoperative MRI can identify locally advanced sigmoid colon cancer (T3cd-T4 tumors) and has potential as the imaging of choice to select patients for neoadjuvant chemotherapy. ADC measurement could be performed in all colonic cancer patients with a good inter-observer agreement.

P75

Polyacetylenes isolated from carrots reduces neoplastic development in Azoxymethane induced rats

M.K. Larsen¹, R. El-Hour², K. Grevsen³, L. Porskjær Christensen², G. Baatrup⁴

¹Kirurgisk Forskningsenhed, SVENDBORG, Denmark

²University of Southern Denmark, ODENSE, Denmark

³Aarhus University, Århus, Denmark

⁴Odense University Hospital, SVENDBORG, Denmark

Background: Earlier studies have shown that feeding Azoxymethane induced rats with carrots and the polyacetylene falcarinol isolated from carrots inhibits the (formation and) growth of aberrant crypt foci in the colon. Further *in vitro* studies of carrot extracts and carrot polyacetylenes on cancer cell lines have confirmed an inhibitory effect on cancer cell growth. Falcarinol and falcarindiol may have a synergistic effect and a therapeutic effect that can be detected in healthy volunteers after the consumption of 200–500 grams of carrot daily. Falcarinol has been shown to induce contact dermatitis in humans and may be considered as a potent immuno-stimulator.

Methods: Twenty rats had supplements containing purified falcarinol and falcarindiol in their diet for 2 weeks and 20 were controls. Then all 40 rats were given the carcinogen Azoxymethane. All animals continued on the designated diet for further 12 weeks and were then euthanized. All macroscopic polyp/cancer were measured, harvested and stained for histology. The occurrence of macroscopic tumors, and tumors larger than 3 mm, was tested between control and treated rats using a chi-square test. The number of Abberent Crypt Foci (ACF) was tested between the groups using Wilcoxon rank sum test.

Results: Fifteen control rats and 8 treated rats had macroscopic tumors (p = 0.027). Number of tumors larger than 3 mm were 6 and 1 (p = 0.032). Also the formation of ACF appears to be reduced in treated rats compared with the control rats, the median number of small ACF was 217.5 in control and 144.5 in treated rats (p=0.0001), for large ACF the corresponding numbers were 7 and 2(p<0.0001). Tumors larger than 3 mm were confirmed by histological analyses.

Conclusion: Dietary supplements with falcarinol and falcarindiol reduces the number of neoplastic lesions formed and perhaps also the growth rate of the polyps.

P76

The application of models to The microRNAs mediated viral oncogenesis

P. Pathmanathan

Centre for Pathological Studies, CHENNAI, India

MicroRNAs are a recently discovered class of small noncoding functional RNAs. These molecules mediate post-transcriptional regulation of gene expression in a sequence specific manner. MicroRNAs are now known to be key players in a variety of biological processes and have been shown to be deregulated in a number of cancers. The discovery of viral encoded microRNAs, especially from a family of oncogenic viruses, has attracted immense attention towards the possibility of microRNAs as critical modulators of viral oncogenesis. The host-virus crosstalk mediated by microRNAs, messenger RNAs and proteins, is complex and involves the different cellular regulatory layers. In this commentary, we describe models of microRNA mediated viral oncogenesis

P77

Incidence Rate of Cancer in India

R. Sobhana, M. Angelo

Centre for Cancer Research and Immunology, Tamilnadu, India

Global comparison shows that India has high incidence rates of cancers of oral cavity, pharynx, & cervix. The age standardized cancer incidence in Indian registries as compared to incidence in certain developed countries is about half to one third in men and about half in women. Based on the data from population based cancer registries in Bangalore, Bombay & Chennai, the estimated number of new cancer cases for the year 2013 was 644,600. Considering no change in age specific incidence, 806,000 cases are expected to occur during the year 2015. About half of the cases among men and one fifth of cases among women, pertain to sites mainly attributable to tobacco use. Overall, about one-third of cancers in India pertain to tobacco related sites. The most common cancer among men is lung & bronchus in Mumbai, Delhi & Bhopal; stomach cancer in Bangalore & Chennai & hypopharyngeal cancer in Barshi. However, all these cancers occupy important ranks in all the registries. The other important cancers sites among men are that of oral cavity, pharynx, larynx & rectum. Cancer of cervix followed by breast cancer are the commonest cancers among women in Barshi, Bangalore, Bhopal & Chennai. Breast cancer is the commonest cancer followed by cervix, in Delhi & Mumbai. Other common forms of cancer among women are mouth, oesophagus, ovary, & stomach. Incidence of cancer of gall bladder is very high in Delhi.

P78

Incidence and risk factors of most prevalent cancers in india

S. Antony

Cancer Research Institute, CHENNAI, India

The incidence and mortality of any disorder in a country are of much importance in order to realize the impact that it creates among the population. A deadly disease like cancer has to be periodically accounted for its incidence in a population. Cancer which mainly arises due to a mutation at a gene level has found to impart a greater impact in India due to its increasing incidence and mortality in the recent years. This review accounts the incidence of major cancer types in India currently using the primary resources. In this regard the incidence, mortality, risk factors and future perspectives of major types of cancers namely lung cancer, breast, cervical and oral cancers have been discussed. The incidence of the above mentioned types of cancers has been compared with the worldwide incidence data and the importance of cancer genetic counseling has been emphasized.

P79

Breast cancer awareness among women in India

S. Nitha, J. Chandran

Centre for Pathological Studies, CHENNAI, India

Our review revealed low cancer literacy of breast cancer risk factors among Indian women, irrespective of their socio-economic and educational background. There is an urgent need for nation- and state-wide awareness programmes, engaging multiple stakeholders of society and the health system, to help improve cancer literacy in India.