

# RECY-Car - Market analysis and technical approach of the end of life vehicle waste

Team members:

A. G. Preda, D. Kelly, M. F. Cruz Rodríguez, M. Krapf, V. Bourgue

Supervisors:

R. Verbal (PICVISA), H. A. González Rojas (UPC-EPSEVG), A. J. Sánchez Egea (UPC-EPSEVG)

**Abstract** — Nowadays recycling is a very important daily activity because of the environmental pollution and the limited natural resources. But for some specific materials a way to recycle is still missing. One share of these materials are plastics when they are black coloured.

In order to get close to this problem, first the state of the art was researched like used dismantling techniques, the materials of a car and the already existing reuse and recycling possibilities. This also includes an overview of the different sorting techniques which are applied on the market (all this leads to materials which cannot be recycled). These are for example plastics when they have a black colour. The most common sorting technologies are working with machine vision, with cameras in the infrared area. Although the infrared waves are not reflected by black colours and subsequently, it is not possible to detect black materials.

In order to estimate the amount and size of the market, a benchmark analysis of the end of life vehicle treatment was conducted. In whole Europe there are about 6,28 M end of life vehicles. With them it is tried to estimate the market volume of these materials and result is a market of 50.2 – 125.6 M €

In order to sort black coloured plastics, the most proper solution according to found criteria was chosen. In this case the choice was an electrostatic sorting method. In this technique the plastic particles are charged electrostatically, because of the friction between the single particles (tribo-charging). Therefore, the most proper machine seems the fluidised bed. The charging is based on electrostatic effects and unequal dielectric constants. That's why the types of plastic are charged different. The amount of the coulomb force is between 1 – 7 nC/g plastic. The charged particles can now be separated them in a voltage field of about 60 kV and 6 mA. In order to separate several types of plastic, only more of those machines need to be configured in a row.

**Keywords**— benchmark, end of life vehicle, black coloured plastic, electrostatic sorting, recycling, tribo-charging

## I. INTRODUCTION

### A. Background

Today's societies are still often indiscriminately using natural resources. This leads often to an environmental pollution and the exploitation of the limited natural resources. These are huge problems of industrialized world. With a good recycling protocol these effects can be at least emasculated.

That's why recycling is quite often demanded by the governments [1]. One share of the waste which cannot be sorted at the moment because of their specific intrinsic properties, e.g. black plastic and tires [2]. Novel technologies are capable of sorting in a better way thanks to the combination of sensors to optimize the discretization process [3]. This problem is general because at the moment black coloured plastics cannot be sorted. They cannot be distinguished by a (machine vision) sorting machine because they are usually working with infrared cameras in order to detect the type of plastic. The infrared waves are not reflected when they interact with black colours surfaces. For that reasons it is not possible to distinguish black coloured plastics.

### B. Previous work

This project was the first collaboration between the Calaf Group (PICVISA) and the Universitat Politècnica de Catalunya. Also at there was no previous researches settled at the Universitat Politècnica de Catalunya. So only general research is able to carry out the basis for this project.

### C. Project Aims

The aims throughout the project were made in steps so it is possible to breakdown the process of recycling a vehicle which is currently happening in the world today. It also tries to find out the laws, regulations and numbers about the amount a car is reused and recycled. To do that, you need to achieve:

- Detailing the recycling procedure of an end of life vehicle and the used techniques starting from a whole end of life vehicle up to the small resulting parts
- Finding out if several parts of a car can be reused and how to handle dangerous parts/liquids
- Describe the recycling route of the materials of a car with detailing the different types, the properties, the recycling route, the future application possibilities and the hazards. Also materials that cannot be recycled at the moment are also mentioned.

Then the previous information leads the project group to focus on the specific problems which are the main points of this work and are listed as following:

- Summarize the actual used sorting techniques
- Benchmark of the recycling industry at the moment and the special position of black coloured plastics
- First technical approach to distinguish between black plastics.

#### D. Actual end of life vehicle treatment

At the moment a vehicle is usually dismantled by hand. This is done more easily in an island dismantling. The many different vehicles and parts are the reasons for this treatment, which do not allow dismantling in an automated line [2]. Usually the car is dismantled in several steps. Always, first the car is drained and the pyrotechnics are removed. Then there are several steps to remove parts from the exterior and the interior. Those parts can be sometimes resold (when they are not broken) or reused in other applications [4] [5]. Otherwise they reduce at least the amount of the unsorted shredder residue. The remaining residue is pressed and shredded. After this the shredder residue is sorted. Several materials can already be sorted and recycled at the moment. For the other materials it is only possible to landfill or to do an energetically recovery (what means burning).

#### E. Sorting

The first step to find a solution for this sorting problem is to describe the actual sorting techniques which are used at the moment to differentiate materials and to see if it is possible to distinguish different types of black coloured plastic. To do that, it is necessary to combine several sorting techniques

They are using different material properties. The following table shows the different sorting methods [6] and if they might be able to sort black coloured plastic:

TABLE I  
ACTUAL SORTING METHODS AND THEIR APPLICATION

Sorting method	Application	Usable to sort black colored plastic
Density sorting	Materials with different densities	Capable
Magnet sorting	Ferromagnetic metals from non-ferromagnetic materials	No
Electro sorting	Types of plastic	Capable
Sorting based on mechanical properties	Films from compact material, packaging, construction waste, bulky waste	No
Flotation sorting	De-inking from paper pulp	No
Sensor based sorting	Plastic materials, glass materials, plastics from metals, PCBs, PVC, paper, wood, construction waste	Capable

According to the below review of methods and applications, it is showed that there might be several techniques interesting for the further development. And with a smart use of one of those techniques it might be possible to solve the black coloured plastic differentiation issue. But there are already some sorting techniques in development which might be able to distinguish black plastic. For the sensor based sorting there are two techniques in development: Plasma spectroscopy induced laser (LIBS) and the Medium infrared thermography (MIR) [3]

## II. METHODOLOGY

### 1. Market analysis

In order to see if it is worth to enter this market of the black coloured plastics, the market of these types of materials were calculated with a market analysis. In this the recycling industry and its mass of materials for one country of the European Union was examined. With this it was possible to calculate the market for these types of materials in this country and in the next step for the whole European Union.

Firstly the German vehicle market was examined, because of the many available numbers of its government [7]. There are 43,431,124 passenger vehicles registered in Germany (in 2013). About 3,300,000 of those were finally deregistered in 2013. But several of them were for example exported, stolen or used in non-public areas. Only 500,322 vehicles got a certificate of destruction which is based on the European law [8]. Those cars are really dismantled and so the source for the black coloured plastic.

In order to find out now the share of all the types of plastic of the end of life vehicles also, the numbers from the German government [7] were used. This source is listing the material groups of the vehicles which are removed during the dismantling process and also the materials after shredding. But this also contains a shredder light fraction, which is the light residue after shredding. This is a mixture of several different materials. According to [9] the shredder light fraction of a vehicle contains normally between 35 and 70 % of all types of plastic. So the assumption was just the arithmetic average which means a share of plastics of 52.5 %. This calculation leads to a mass of 75,000 t (146 kg/car) of all types of plastic in all the end of life vehicles in Germany in 2013. 68,000 t of these plastics are already reused (1,500 t) and recycled (66,500 t) [7]. This means that there are 7,000 t (16.6 kg/car) of all different plastics types of a car left (in Germany, 2013) which are not recycled yet. The literature [10] says that about 80 % of all the plastics in a car are thermoplastics. This materials are usually recyclable ones [11] [2] and would gain the most profit in reselling.

In order to calculate now the whole market in the EU, this value (per car) is multiplied with the number of really destructed cars. With the number of 6,280,000 end of life vehicles in all the member states of the EU in 2012 [12] the value can be calculated. The assumption therefore is that the cars in the EU have (according to the used materials) the same share of plastics than in Germany.

### 2. Separate black coloured plastic

#### a) Brainstorming

In order to try to solve this specific waste sorting problem, a brainstorming took place to propose the best solution. Along the brainstorming several ideas, without thinking of technical limitations, were collected.

The ideas are:

- Acid: Spray an acid on the plastic waste to create a pattern (which is not black). Then it might be possible to distinguish them by cameras and post processing analysis. Then a separation also would be possible.

- Hot stick: Use a hot stick to deform the plastic parts. Thermoplastics are probably going to react in a different ways depending on the material properties. Then there might be a separation possible
- Electrostatic: Use electrostatic properties-> Load up the plastics with electricity. Then some plastic types will be loaded positive, others negative. Finally, there would be a separation between positive and negative parts due to a magnetic field
- Density: Use different densities to sort different types of plastics and create therefore a sorting application. So the material with the higher density might be separated from the material with the lower density
- Heat absorption: Heat the plastics, and with the weight and the volume it might be possible to guess between different head absorption levels

To evaluate and compare these ideas a ponderation table was developed taking into account several criteria. These criteria were found with a thoroughly literature review [13] and also with some advises of the company PICVISA.

The found criteria are:

- Low costs (of the development, production and use)
- The simplicity of production
- The feasibility of the technique
- If the technique can be combined with machine vision (PICVISA's interest)
- The effects on the environment (which should be as low as possible)
- The effect on the plastic which is sorted (this also should be low, because a destroyed plastic cannot be sold and gain any profit)
- Shorter time of the sorting process
- An accurate sorting process
- The time between a service at the sorting machine (when a check-up of the parts change of parts of the sorting machine is necessary)

#### b) Analytical hierarchy process

In order to assess the technical proposals, first the importance of the single criteria needs to be found. For this an analytical hierarchy process [14] was applied. To do this the criteria were always compared in pairs. According to the level of importance of the one criteria, the higher rating this criterion gets. The rating was done in collaboration with the PICVISA company. In this way all the criteria were compared to each other and, ultimately, the weight factors were calculated for each criterion.

The criteria to assess the ideas for sorting the black coloured plastics and their weight factors are listed in the following table.

TABLE 2  
CRITERIA TO ASSESS THE IDEAS AND THEIR RESULT OF THE ANALYTICAL HIERARCHY PROCESS

Criteria	Weight factor
Low costs (of the development, production and during the use)	0.24
The simplicity of production	0.02
The feasibility of the technique	0.10
Simplicity of the technique	0.07
If the technique can be combined with machine vision	0.05

The effects on the environment (which should be as low as possible)	0.16
The effect on the plastic which is sorted (this also should be low, because a destroyed plastic cannot be sold and gain any profit)	0.15
Short time to sorting process	0.05
An accurate sorting process	0.13
The time between a service at the sorting machine (when a check-up of the parts change of parts of the sorting machine is necessary)	0.03

#### c) Decision matrix

The already explained ideas to solve the problem were now assessed and rated in a decision matrix. This assessment was carried out by 5 engineers under their independent opinions. Therefore, each idea is assessed according to each criterion and the higher the fulfilment of a criterion is the higher is the grade. Then each grade is multiplied with the calculated weight factor and all those products were summed up for each idea. With this procedure it is possible to find the most proper solution for sorting black coloured plastic according to the given criteria. The assessment was done by the knowledge which was so far achieved. The following figure shows the ratings and the final result.

TABLE 3  
DECISION MATRIX

	Low cost (in total)	Simple way of production	Feasibility of the technique	Simplicity of the technique	Combination w. MV possible	Low effects on Environment	Low effects on Plastic	Sorting accuracy	Sorting Time	Time between machine-service	Result
Weight factor	0.24	0.02	0.1	0.07	0.05	0.16	0.15	0.13	0.05	0.03	
Acid	5	8	4	2	9	2	2	5	2	2	<b>3.8</b>
Hot stick	7	2	2	3	0	3	4	3	3	7	<b>3.9</b>
Electrostatic	6	6	9	7	0	6	9	9	8	7	<b>7.1</b>
Density	6	6	2	6	0	7	8	4	4	7	<b>5.4</b>
Heat absorption	6	6	2	5	2	4	4	3	3	5	<b>4.1</b>

### III. RESULTS

#### A. Benchmark analysis

The assumption is now that the plastics which are (at the moment) not-recyclable, have the same share of thermoplastics like the whole car. But probably only  $\frac{3}{4}$  of these plastics are black and might be sorted with the new technique (10 kg/car). This assumption is based on the extraordinary huge share of black parts in the whole car (around the engine, interior,

exterior). The price of recycled-plastic was on the 13<sup>th</sup> of May in 2016 (depending on the type and country) usually between 0.0-2€/kg [15]. This means for the thermoplastics of a car a gain of 8-20 €/car. First in Germany with the 500,322 vehicles and the calculated value of black plastic in a car, would be a market of 4 to 10 M €.

Finally using the same assumptions, there would be a market of **50.2 – 125.6 M €** for the black plastic materials of the end of life passenger vehicles in the 28 countries in the European Union per year.

### B. Best approach to sort black coloured plastic

The most proper solution according to the proposed criteria is the electrostatic separation because this separation can sort the following materials [16]:

- A mixture of electric conductors and non-conductors (metals and plastic)
- A mixture of plastics

#### 1. The procedure

For separating the plastics, the method is based on different charging of the plastics when they are put in contact to each other. Then it is possible to separate the plastics in a high voltage electric field. Therefore, the plastics need to have different dielectric constants [16].

##### a) The first step: create an electric charging on the plastic.

This can be done by three methods [2]:

- Charging by friction of the particles when they are put in contact (tribo-charging)
- Polarisation in the electric field
- Charging in a corona field.

The corona field and the polarisation is only working with metals, for plastics only the tribo-charging is feasible. In this method is a contact between the plastic particles is created. The tribo-charging creates un-similar electric charges on the different types of plastic.

The friction can be created by an intensive particle-particle contact or particle-wall contact [16]. For example therefore can be used, a mixing drum or a fluidised bed [2].

According to [17] the fluidised bed, where the particles are blown by air and get in contact to each other with a friction, creates the highest charging.

The charging of the plastic materials itself depends on the tribo-electric charging row [18] [19]. With this it can be predicted which material will be charged positive and which one negative. The charging creates a coulomb force, the literature speaks of an amount of 1 – 7 nC/g plastic. The amount depends on the charging method in step 1 and also on the size of the particles. So the fluidised bed is able to create the highest charging of 7. Also smaller particles usually can be charged with a higher value [17].

##### b) The second step is the separation in a high voltage field.

Those different charged plastic types can be now separated during the second step in a high voltage field of 60 kV and a current of 6 mA during a free fall [17]. In this sense the negative particles are attracted by the positive electrode, while the

positive materials from the negative one. During the separation there is a coulomb force, the gravity force and maybe a centrifugal force (because of the deviation force) on the particles.

#### 2. Requirements for electrostatic sorting

In order to have a well working sorting and a high accuracy several points need to be followed [16]:

- Clean Material (No dust, dirt, oil)
- Dry material
- Total shredded (separated) material
- Size of the sorting material smaller than 10 mm
- Material with different dielectric constants

#### 3. Possible separation

The literature [2] already says, that it is possible to sort:

- HDPE/PP
- PET/PVC
- PVC/Rubber
- PP/PS
- ABS/PMMA
- PVC/PE
- Plastics/very fine metal particles

According to this a first concept of machine can be done. The following figure shows an example how this machine might look like. In part 1 there would be the electrostatic in a fluidised bed, like it was described. There the particles are charged electrostatically. In part 2 the charged particles are separated during the free fall because of the electrostatic field. The separated plastics are collected in two different boxes (3).

FIGURE 1  
SCHEMATIC REPRESENTATION OF AN ELECTROSTATIC SORTING METHOD

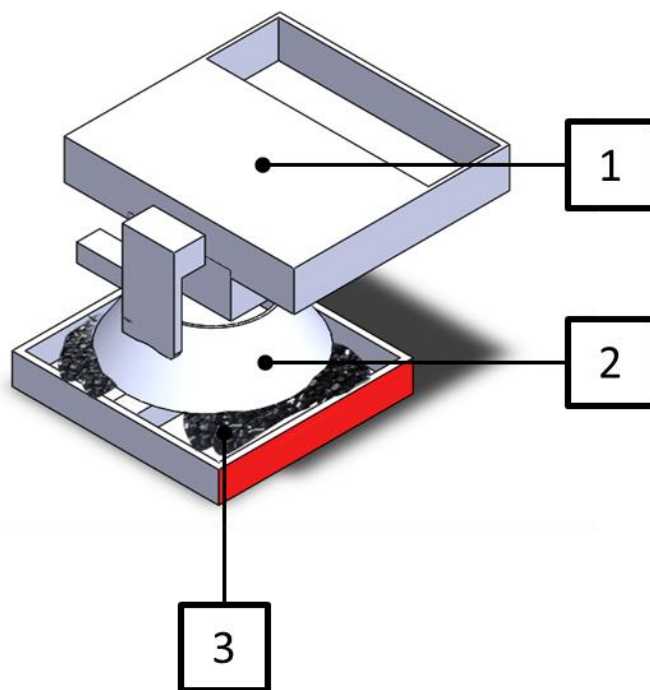

#### 4. *Sorting of several materials*

The idea which was described so far is just possible to sort the plastics in a positive and a negative charged part. Right after this step there is just a half of positive charged plastic particles and one half of negative ones. This is already a first separation and for a mixture of only two different plastic types it would be already enough.

But usually, different types of plastic are found in the heterogeneous waste-mixture of a car. For that reason, the idea is to use more sorting steps to keep on sorting materials which has the same layout like the first machine. The tribo-electric charging row should allow a sorting of different plastic materials in several steps in order to distinguish them. This step needs to be done as often until all the materials are separated.

The literature listing eleven often used types of plastics in a car [20] [21]. These materials present fifteen different modules and it would be possible to sort sixteen types of plastic.

In a further step the electrostatic sorting machine might be combined with a machine vision sorting machine. This would offer the possibility first to sort the coloured plastics out. They are recognised and blown out by the machine vision. Then they are collected in boxes. The black coloured plastics which cannot be detected remain on the conveyor and fall into the electrostatic sorting machine which is arranged at the end. This machine is sorting the plastics like it was already described. This would offer the possibility to sort even more different materials. The following figure shows an example how this combination might look like.

FIGURE 2  
COMBINATION: MACHINE VISION - ELECTROSTATIC SORTING MACHINE

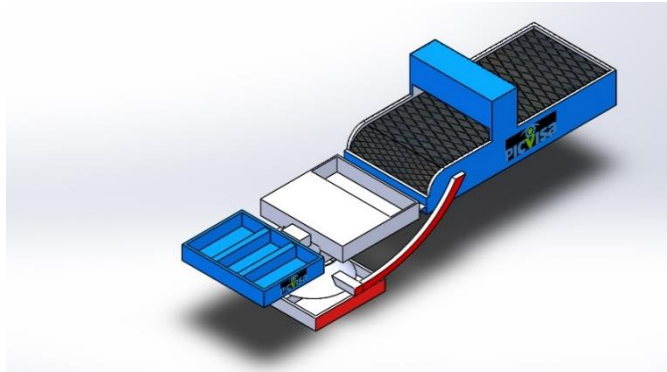

#### IV. CONCLUSION

##### A. *Benchmark analysis*

This project proposed an estimation of the market volume of black coloured plastics of all the end of life vehicles in the whole European Union. The result is an amount of **50.2 – 125.6 M €** per year in the 28 countries in the European Union. This seems like a huge market and might be an interesting business field.

##### B. *Sorting black coloured plastics*

The other important topic was to choose the most proper solution for sorting black coloured plastic. Therefore, the used methods carried out that an electrostatic sorting method would

be (according to the chosen criteria) the most proper solution.

The advantages of this solution are:

- 1) It doesn't destroy the plastics
- 2) The effects on the environment are low
- 3) The time of sorting is quite fast
- 4) There are already very high accuracies of sorting documented [16].

#### ACKNOWLEDGMENT

The company PICVISA is acknowledgement for their contribution. The authors also want to thank the Universitat Politècnica de Catalunya especially the Escola Politècnica Superior d'Enginyeria de Vilanova i la Geltrù, the Erasmus + program of the European Union and for the support the home universities of the students: Ecole Supérieure d'Ingénieur de Reims (France), Institute of Technology Sligo, Ireland, Politehnica University of Bucharest (Romania), Tecnológico de Monterrey, campus Mty, (Mexico) and University of Applied Sciences and Arts Coburg (Germany)

#### V. REFERENCES

- [1] European Commission, "http://ec.europa.eu," 2016. [Online]. Available: <http://ec.europa.eu/environment/waste/elv/>. [Accessed 01 04 2016].
- [2] H. Martens, *Recyclingtechnik*, Heidelberg: Spektrum Akademischer Verlag, 2011.
- [3] C. Delavelle and C. Marioge, "State of the art of waste identification and sorting technologies," ADEME, Anger Cedex, 2012.
- [4] B. Bilitewski, G. Härdtle and K. Marek, *Abfallwirtschaft*, Berlin: Springer, 2000.
- [5] J. Schmidt, *Altautoverwertung und -entsorgung*, Renningen: expert verlag, 1995.
- [6] G. Schubert, "Zerkleinerungstechnik für nichtspröde Abfälle und Schrotte," *Aufbereitungstechnik*, vol. 43, no. 9, pp. 6-23, 2002.
- [7] Federal Environment Agency Germany and Federal Ministry for the Environment, Nature Conservation, Building and Nuclear Safety, "Description of the data submitted according to Commission Decision 2005/293/EC on the monitoring of the reuse/recovery and reuse/recycling targets on ELVs," Dessau-Roßlau (Germany), 2015.
- [8] The European parliament and the council of the European Union, *2000/53/EC - End of life vehicles*, Brussels, 2000.
- [9] F. Wallau, *Kreislaufwirtschaftssystem Altauto*, Wiesbaden: Deutscher Universitätsverlag GmbH, 2001.
- [10] Consultic, "Statista - Das Statistik-Portal," 2016. [Online]. Available: <http://de.statista.com/statistik/daten/studie/275072/umfrage/anteile-der-verwendeten-plastiksorten-in-der-europaischen-automobilindustrie/>. [Accessed 09 04 2016].
- [11] E. Roos and K. Maile, "Werkstoffkunde für Ingenieure," Springer-Vieweg, Heidelberg (Germany), 2015.
- [12] European Commission, "http://ec.europa.eu," 2016. [Online]. Available: [http://ec.europa.eu/eurostat/statistics-explained/index.php/File:Total\\_number\\_of\\_end-of-life\\_vehicles,\\_EU-27,\\_2006%E2%80%932012.png](http://ec.europa.eu/eurostat/statistics-explained/index.php/File:Total_number_of_end-of-life_vehicles,_EU-27,_2006%E2%80%932012.png). [Accessed 01 04 2016].
- [13] J. Feldhusen and K. H. Grote, "Pahl/Beitz Konstruktionslehre," Springer-Vieweg, Berlin, 2013.
- [14] G. Kou, D. Ergu, Y. Peng and Y. Shi, *Data Processing for the AHP/ANP*, Heidelberg: Springer, 2013.

- [15] Plasticker, "plasticker - the home of plastic," 2016. [Online]. Available: <http://plasticker.de/recybase/listaog.php?aog=A&spec=&stext=&mat=&snation=DEU&art=Recyclat&minmax=mind.&menge=&einheit=to&form=&preis=&farbe=schwarz&pack=&befehl=Suche+starten>. [Accessed 13 05 2016].
- [16] R. Köhnlechner and S. Sander, "Praktischer Einsatz elektrostatischer Separatoren in der Sekundärrohstoffindustrie," *BHM*, vol. 154, no. 4, pp. 136-139, 2009.
- [17] M. El-Mouloud Zelmat, M. Rizouga, K. Medles, M. Miloudi and L. Dascalescu, "Experimental Comparative Study of Different Tribocharging Devices for Triboelectric Separation of Insulating Particles," Sidi Bel-Abbes (Algeria) and Angouleme (France), 2012.
- [18] H. Schubert, *Handbuch der mechanischen Verfahrenstechnik*, Weinheim: Wiley-VCH, 2003.
- [19] W. Nickel, *Recycling-Handbuch*, Düsseldorf: VDI, 1996.
- [20] E. Baur, T. A. Osswald and N. Rudolph, *Saechtling Kunststoff Taschenbuch*, München: Hanser-Fachbuch, 2013.
- [21] VKE AA Statistik und Marktforschung, *Kunststoffverbrauch in der Automobilindustrie; Westeuropa 1998 nach Werkstoffen/Anwendungen*, Verband Kunststoffherstellende Industrie E.V., 1998.
- [22] E. Moeller and H. Martens, "Kap. 3: Recycling," in *Handbuch Konstruktionswerkstoffe*, München, Hanser, 2008, pp. 879-913.