

UNIVERSITY OF WESTMINSTER



**WestminsterResearch**

<http://www.wmin.ac.uk/westminsterresearch>

**Improvement of third-order intermodulation product of RF and microwave amplifiers by injection.**

**Colin S. Aitchison<sup>1</sup>**  
**Modeste Mbabele<sup>1</sup>**  
**M. Reza Moazzam<sup>2</sup>**  
**Djuradj Budimir<sup>3</sup>**  
**Fazal Ali<sup>4</sup>**

<sup>1</sup> School of Electronic Engineering, Information Technology and Mathematics, University of Surrey

<sup>2</sup> Siemens Information and Communication Mobile, San Diego, CA, USA

<sup>3</sup> School of Informatics, University of Westminster

<sup>4</sup> Nokia Mobile Phones, San Diego, CA, USA

Copyright © [2001] IEEE. Reprinted from IEEE Transactions on Microwave Theory and Techniques, 49 (6). pp. 1148-1154.

This material is posted here with permission of the IEEE. Such permission of the IEEE does not in any way imply IEEE endorsement of any of the University of Westminster's products or services. Internal or personal use of this material is permitted. However, permission to reprint/republish this material for advertising or promotional purposes or for creating new collective works for resale or redistribution must be obtained from the IEEE by writing to [pubs-permissions@ieee.org](mailto:pubs-permissions@ieee.org). By choosing to view this document, you agree to all provisions of the copyright laws protecting it.

---

The WestminsterResearch online digital archive at the University of Westminster aims to make the research output of the University available to a wider audience. Copyright and Moral Rights remain with the authors and/or copyright owners. Users are permitted to download and/or print one copy for non-commercial private study or research. Further distribution and any use of material from within this archive for profit-making enterprises or for commercial gain is strictly forbidden.

---

Whilst further distribution of specific materials from within this archive is forbidden, you may freely distribute the URL of the University of Westminster Eprints (<http://www.wmin.ac.uk/westminsterresearch>).

In case of abuse or copyright appearing without permission e-mail [wattsn@wmin.ac.uk](mailto:wattsn@wmin.ac.uk).

# Improvement of Third-Order Intermodulation Product of RF and Microwave Amplifiers by Injection

Colin S. Aitchison, *Fellow, IEEE*, Modeste Mbabele, *Member, IEEE*, M. Reza Moazzam, *Senior Member, IEEE*, Djuradi Budimir, *Member, IEEE*, and Fazal Ali, *Fellow, IEEE*

**Abstract**—This paper discusses the improvement in the third-order intermodulation product (IM3) performance obtainable from RF and microwave amplifiers by two alternative injection techniques. The first is the addition to the amplifier input of the second harmonics of the input spectrum and the second is the addition to the amplifier input of the difference frequencies between the spectral components of the input signal. Both techniques are considered in theory, by simulation and in practice. Both techniques give useful improvements in two-tone IM3 performance. The second harmonic technique reduced the IM3 level by 43 dB in an amplifier at 835 MHz. The difference-frequency technique gave a reduction of 48 dB in an amplifier at 880 MHz. The difference-frequency technique also gives a greater improvement for complex spectra signals.

**Index Terms**—Intermodulation, intermodulation distortion, microwave power amplifiers, radio-frequency amplifiers.

## I. INTRODUCTION

RECENT developments in communication systems require that RF and microwave amplifiers shall have an excellent linearity performance. This parameter is often specified in terms of intermodulation levels, usually the third. In band, the carrier level C, and third-order intermodulation product (IM3) level I, give the carrier to intermodulation ratio (C/I), or in adjacent channels, the adjacent channel power ratio (ACPR). It is also desirable for amplifiers, particularly power amplifiers, to be of high efficiency and this requires large voltage and current swings. These militate against low intermodulation levels. Thus, it is usually necessary to use special techniques to improve the intermodulation behavior of a power amplifier at a given output power while maintaining an acceptable power-added efficiency. The traditional techniques, which have been used for this purpose, are feedback, predistortion, and feedforward [1].

The technique that is the subject of this paper is different from the above in that an improvement in the amplifier IM3 is obtained by using the nonlinearity of the amplifier itself to generate a second pair of IM3 products and arranging that the second pair are of appropriate amplitude and phase for cancellation with the first set to occur [2]. The technique is applied in either of two different forms. The second harmonic of the input spectrum can

be applied to the amplifier input, together with the signal to be amplified [2]. Alternatively, the frequency difference between a set of equally spaced input tones can be applied to the amplifier input, together with the signal to be amplified [3]. Details are given below of the theory, simulation predictions, and bench experiments.

## II. THEORY

The analysis below assumes a weakly nonlinear amplifier with a MESFET active device. We assume that the amplifier nonlinearity can be expressed in terms of a power series connecting the drain current  $i_d$  to the gate voltage  $v_{in}$  by the expression

$$i_d = g_{m1}v_{in} + g_{m2}v_{in}^2 + g_{m3}v_{in}^3. \quad (1)$$

If the input voltage consists of two tones given by the expression

$$v_{in} = A_1 \cos \omega_1 t + A_2 \cos \omega_2 t \quad (2)$$

then the usual analysis yields the expression

$$0.75A_1A_2^2g_{m3} \cos(2\omega_2 - \omega_1)t \quad (3)$$

for the IM3 product at the frequency  $(2\omega_2 - \omega_1)$  and a similar expression for the IM3 product at frequency  $(2\omega_1 - \omega_2)$ .

If we now add to the amplifier input voltage components at the second harmonic of the two input frequencies, we can write

$$v_{in} = A_1 \cos \omega_1 t + A_2 \cos \omega_2 t + A_{11} \cos(2\omega_1 t + \phi_1) + A_{22} \cos(2\omega_2 t + \phi_2) \quad (4)$$

where the harmonic frequencies have amplitudes and phases  $A_{11}$ ,  $A_{22}$ ,  $\phi_1$  and  $\phi_2$ , respectively. The expression for the IM3 drain current at the frequency  $(2\omega_2 - \omega_1)$  is then given by

$$0.75A_1A_2^2g_{m3} \cos(2\omega_2 - \omega_1)t + A_1A_{22}g_{m2} \cos(2\omega_2 t - \omega_1 t + \phi_2) \quad (5)$$

when other small terms are neglected.

A similar expression is obtained for the IM3 product of the drain current at  $(2\omega_1 - \omega_2)$ . Inspection of (5) shows that the appropriate choice of  $A_{22}$  and  $\phi_2$  results in a net zero IM3 drain current component at  $(2\omega_2 - \omega_1)$ . Similarly, the appropriate  $A_{11}$  and  $\phi_1$  removes IM3 at  $(2\omega_1 - \omega_2)$ . Thus, the addition of the second harmonics of the two input tones of appropriate amplitude and phase into the amplifier together with the original tones results in elimination, in principle, of IM3 components in the drain current.

Manuscript received February 25, 2000; revised February 12, 2001.

C. S. Aitchison and M. Mbabele are with the School of Electronic Engineering, Information Technology and Mathematics, University of Surrey, Guildford GU2 7XH, U.K.

M. R. Moazzam is with Siemens Information and Communication Mobile, San Diego, CA 92127 USA.

D. Budimir is with the Department of Electronic Systems, University of Westminster, London W1M 8JS, U.K.

F. Ali is with Nokia Mobile Phones, San Diego, CA 92131 USA.

Publisher Item Identifier S 0018-9480(01)04434-9.

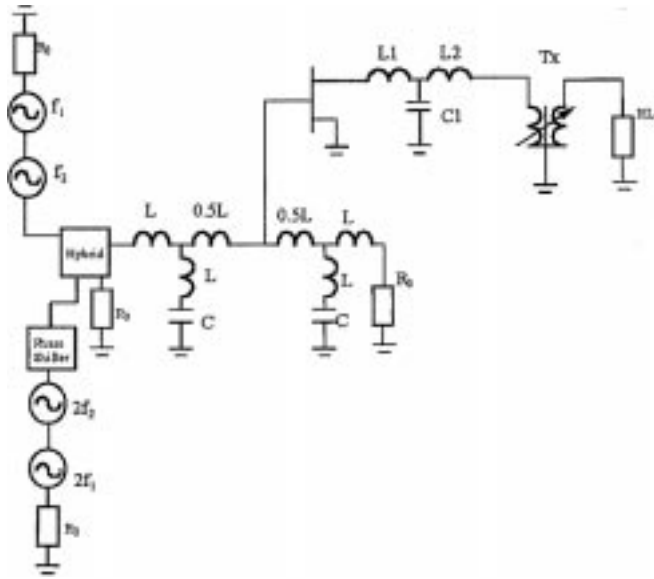

Fig. 1. Amplifier configuration used to simulate IM3 performance with and without the addition of second harmonic frequencies.

Alternatively, a signal of amplitude  $A_{21}$  and phase  $\phi_{21}$  at the difference frequency  $(\omega_2 - \omega_1)$  can be injected into the amplifier together with the original two-tone input to give

$$v_{in} = A_1 \cos \omega_1 t + A_2 \cos \omega_2 t + A_{21} \cos (\omega_2 t - \omega_1 t + \phi_{21}). \quad (6)$$

The IM3 component of drain current at  $(2\omega_2 - \omega_1)$  is then given by

$$0.75A_1 A_2^2 g_{m3} \cos(2\omega_2 - \omega_1)t + 0.75A_1 A_{21}^2 g_{m3} \cos(2\omega_2 t - \omega_1 t - 2\phi_{21}) \quad (7)$$

with a similar expression for the frequency  $(2\omega_1 - \omega_2)$ . Again, appropriate choice of  $A_{21}$  and  $\phi_{21}$  results in a zero IM3 drain current at the frequency  $(2\omega_2 - \omega_1)$ .

Thus, there are two similar techniques which should lead, in principle, to a reduction in the IM3 product in the drain current of the MESFET amplifier. The following sections consider both the simulated performance using both of these techniques and the practical results that have been obtained on the bench with the techniques.

### III. SIMULATION

The intermodulation performance of the second harmonic injection technique has been simulated using the circuit shown in Fig. 1 using both LIBRA and MDS. This shows two frequency generators at  $\omega_1$  and  $\omega_2$  and second harmonic generators at  $2\omega_1$  and  $2\omega_2$ , which feed the amplifier input circuit centered on 2.50 GHz. A nonresonant input circuit is provided at the gate in the form of a single-stage artificial transmission line, correctly terminated. The drain is resonated at the output frequency and a variable resistive load is provided. The Curtice cubic model 3 for the amplifier FET has been used. Fig. 2 shows the predicted IM3 spectral output from the amplifier with an input of two tones of equal amplitude at 2.50 and 2.51 GHz. Addition of the two second harmonics of these two tones with op-

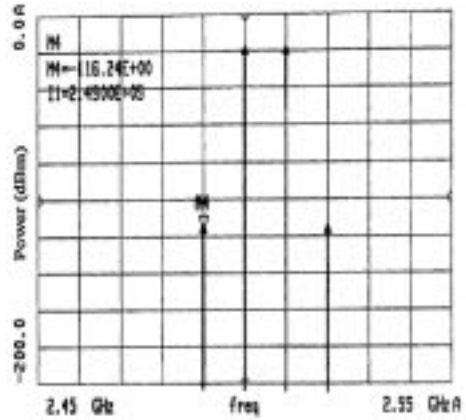

Fig. 2. Two-tone output spectrum without second harmonic injection.

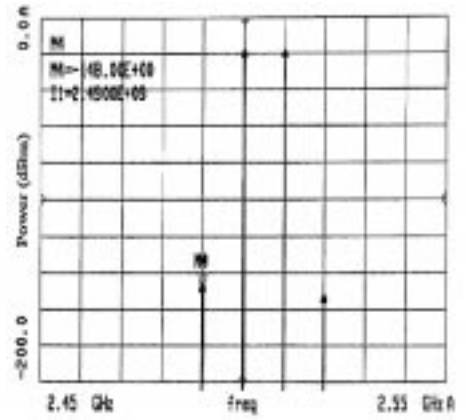

Fig. 3. Two-tone output spectrum with optimized second harmonic injection.

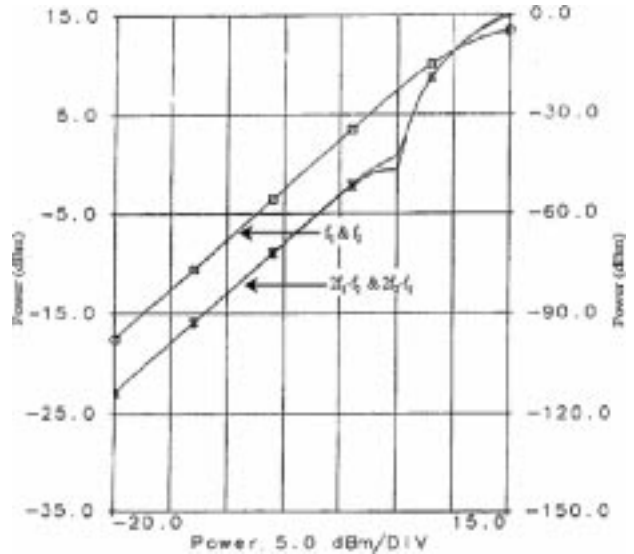

Fig. 4. Fundamental signals and IM3 distortion products of 2.50-GHz amplifier as function of input power for two-tone input without injection of second harmonics.

timized amplitudes and phases gives the simulated performance shown in Fig. 3 and demonstrates that IM3 has been reduced by 32 dB at 2.50 GHz and 40 dB at 2.51 GHz without change in the fundamental output level. Figs. 4 and 5 show the corresponding IM3 and fundamental output levels as a function of input power, illustrating an improvement in IM3 of 30 dB (Note

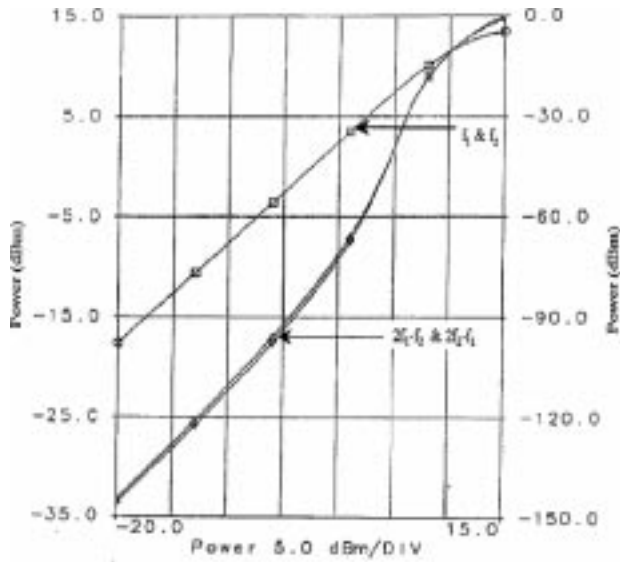

Fig. 5. Fundamental signals and IM3 distortion products of 2.50-GHz amplifier as function of input power for two-tone input with injection of second harmonics.

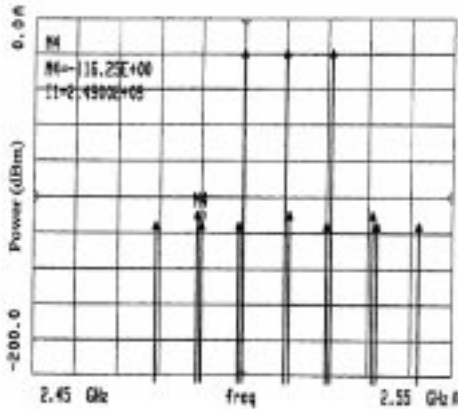

Fig. 6. Three-tone output spectrum without second harmonic injection.

that the IM3 right-hand scale is 30 dB/div, whereas the fundamental left-hand scale is 10 dB/div). The amplitude and phase of the second harmonics are optimized for each input power level in accordance with (5), illustrating the agreement between simulation and theory until the onset of significant nonlinearity. The simulated improvement in IM3 is in agreement with the theory outlined above for an input signal consisting of two tones with the addition of their second harmonics.

In general, the input signal to a communication amplifier is not restricted to two sinusoids, as in the two-tone intermodulation test, and it is, therefore, of interest to consider a more complicated input spectrum. A convenient spectrum consists of three tones of identical amplitude. Analysis of this situation shows that the IM3 products can now arise through two separate routes. The first, described as the first kind, are of the form  $(2\omega_1 - \omega_2)$ ,  $(2\omega_3 - \omega_1)$ , etc. and the second are of the form  $(\omega_2 + \omega_1 - \omega_3)$ ,  $(\omega_1 + \omega_3 - \omega_2)$ , etc., which are described as the second kind.

The same simulation procedure as for the two-tone input signal has been used for the three-tone input signal at frequencies  $\omega_1$ ,  $\omega_2$ , and  $\omega_3$  with second harmonics at  $2\omega_1$ ,  $2\omega_2$ , and

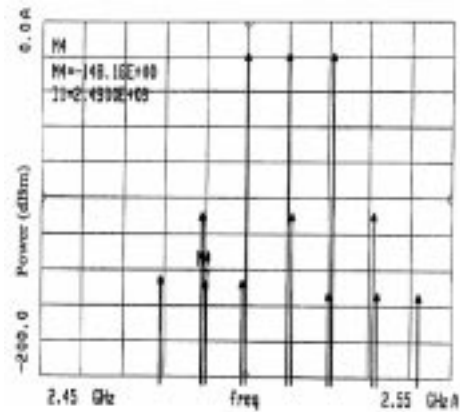

Fig. 7. Three-tone output spectrum with optimized second harmonic injection.

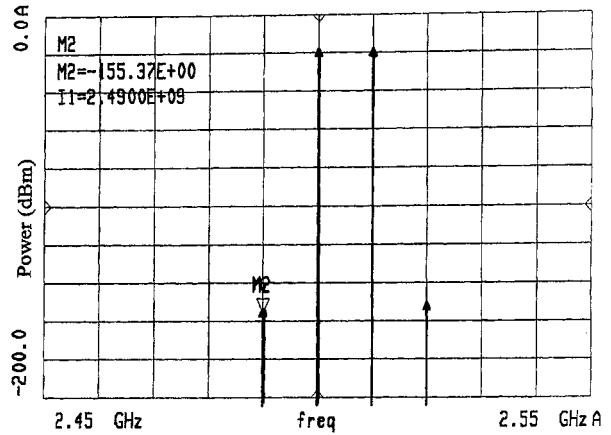

Fig. 8. Two-tone output spectrum with optimized difference-frequency injection.

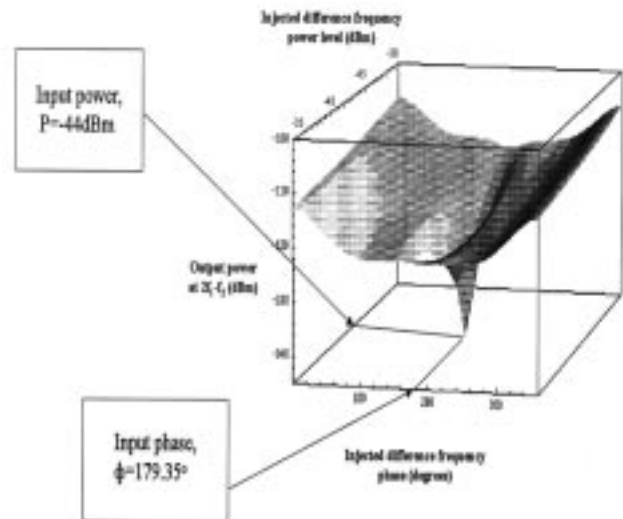

Fig. 9. IM3 ( $2f_1 - f_2$ ) output power level as function of difference-frequency signal phase and amplitude.

$2\omega_3$ . Fig. 6 shows the simulated spectrum of the drain current for the 2.5-GHz amplifier with three input tones of equal amplitudes with a small difference in the frequency separation between the three tones so that the contribution of the two kinds of IM3 can be distinguished. The simulator was then

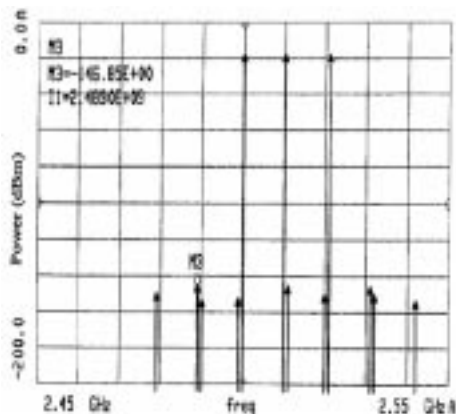

Fig. 10. Three-tone output spectrum with optimized amplitude and phase of difference frequencies.

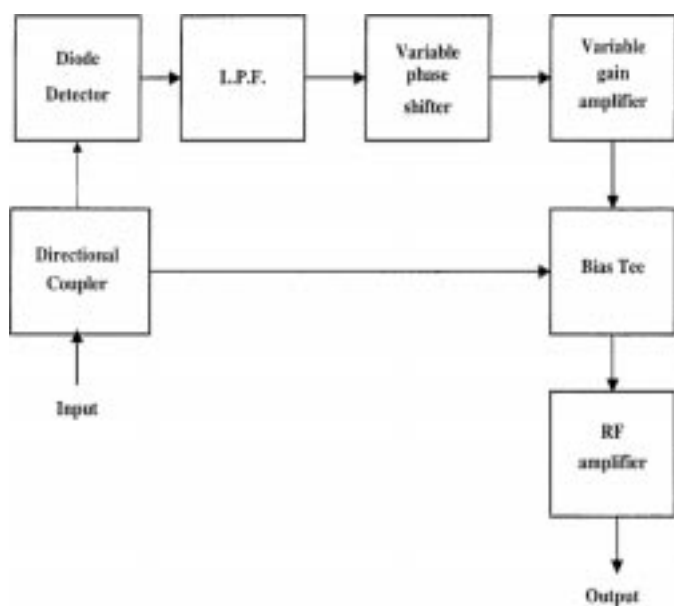
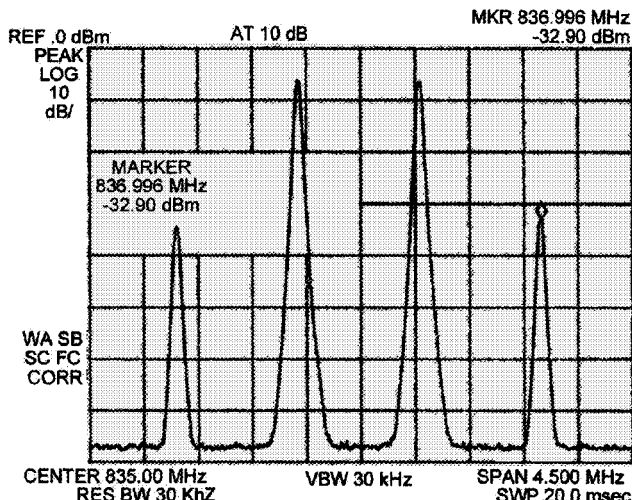

Fig. 11. Difference-frequency extraction experimental arrangement.

used to optimize the amplitudes and phase of the three second harmonics, and the consequent output spectrum is shown in Fig. 7. This illustrates that the second harmonic technique has reduced the first kind of IM3 product by about 38 dB, but has failed to reduce the second kind of IM3 product. This result confirms the analysis and suggests that the second harmonic technique may be of restricted value as a means of reducing the intermodulation level of an amplifier with a complicated input spectrum.

We now move to the simulation of the difference frequency technique. The configuration was similar to that of Fig. 1, except that the injected signal is now at the difference frequency ( $\omega_2 - \omega_1$ ) provided by one generator at that frequency instead of the two generators at  $2\omega_1$  and  $2\omega_2$ . The spectrum at the amplifier output for the two-tone difference frequency injected at the input is shown in Fig. 8. Comparison of this with Fig. 2 (no injected signal) shows a reduction of 39 dB in IM3. This simulator prediction is in agreement with the analysis of Section II. Fig. 9 is a three-dimensional plot of IM3 level as a function of both injected phase and amplitude of the injected difference-frequency signal for a fixed two-tone input signal level. This illustrates the



(a)

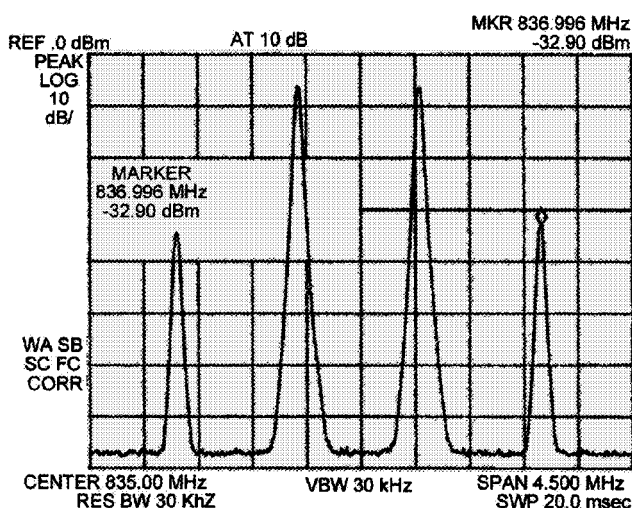

(b)

Fig. 12. Output spectrum of the HBT power amplifier at 28-dBm output: (a) before and (b) after applying the second harmonic technique.

dependence of IM3 level reduction on the injected phase and amplitude: for a 25-dB improvement, amplitude must be maintained to better than  $\pm 0.5$  dB and phase better than  $\pm 5^\circ$ .

The simulator has also been used for the three-tone input with the injection of the difference frequencies, and the output spectrum is shown in Fig. 10. This shows that both the first and second kind of IM3 products have been reduced. Comparison with Fig. 6 shows the reduction is close to 40 dB for each component of the intermodulation distortion spectrum shown. This result contrasts favorably with the second harmonic reduction technique described above, which only reduced the first kind of IM3 with a three-tone input.

#### IV. EXPERIMENTAL INVESTIGATION

The concepts analyzed and simulated, as described above, have been experimentally investigated on the bench. The technique used to obtain the difference frequency is illustrated in Fig. 11. The input signals are fed to a p-n detector diode through a directional coupler and the remainder of the input signal is

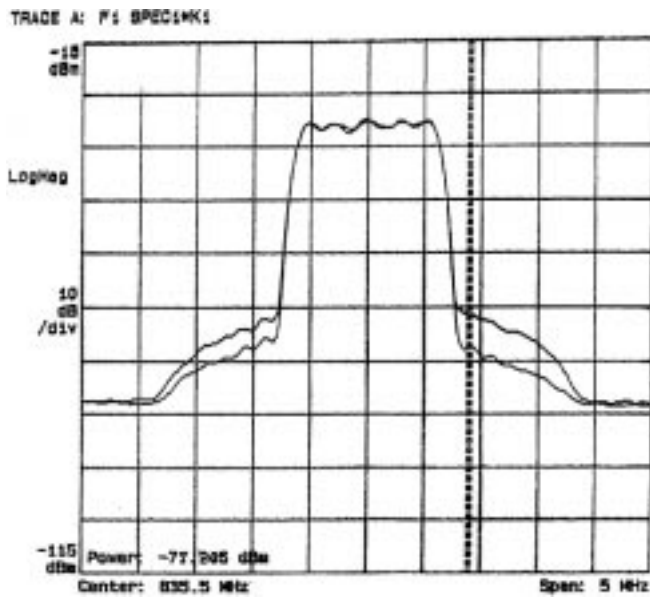

Fig. 13. Output spectrum of 28-dBm HBT 835-MHz amplifier modulated with CDMA 1.23-MHz OQPSK without (upper curve) and with (lower curve) second harmonic injection.

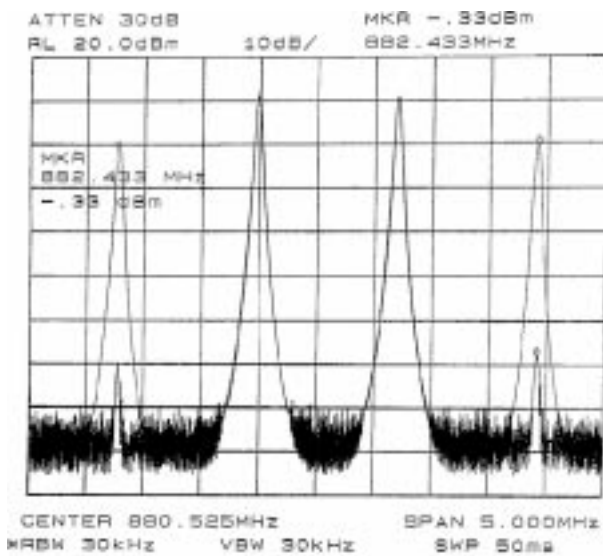
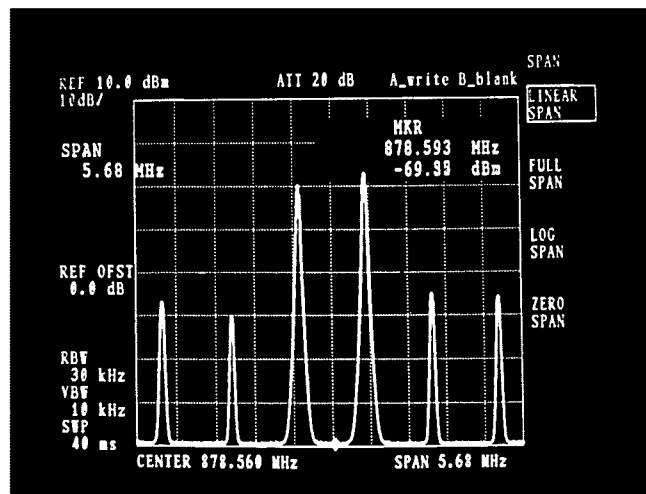

Fig. 14. Spectrum of 880-MHz amplifier output with and without the difference-frequency injected signal showing an improvement in  $C/I_{M3}$  of 48 dB.

passed directly to the nonlinear amplifier. The difference frequency, typically 1 MHz, is generated in the diode and passed through a low-pass filter (LPF), variable phase shifter, and amplifier of variable gain before being injected into the nonlinear amplifier input through a tee section. The variable phase shifter and amplifier are used to adjust the phase and amplitude of the injected difference-frequency signals. A very similar configuration is used for the second harmonic frequency generator. Again, a p-n diode is used to obtain the required second harmonic components.

Ali *et al.* [4] have investigated the second harmonic technique using a heterojunction bipolar transistor (HBT) amplifier at 835 MHz with an output power of 28 dBm. The original output spectrum and improved spectrum are shown in Fig. 12 and show that  $IM_3$  has dropped by 43 dB using the technique.



(a)

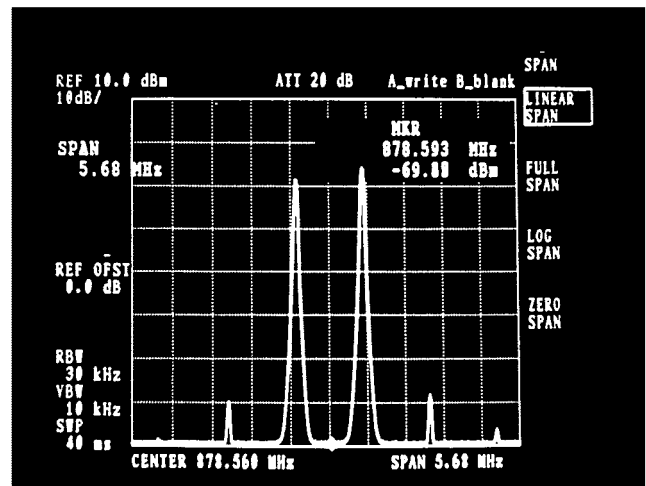

(b)

Fig. 15. Two-tone response of 880-MHz amplifier without (upper) and with (lower) injection of difference frequency showing  $IM_3$  improvement of 20 dB and fifth-order intermodulation improvement of over 30 dB.

The output spectrum from the same 28-dBm power amplifier with a 1.23-MHz channel bandwidth offset-QPSK code-division multiple-access (CDMA) input is shown in Fig. 13 with and without the injection of the second harmonic. An average improvement in ACPR of 6 dB for 30-kHz bandwidth at  $\pm 900$  kHz offset is obtained. A similar result has been obtained with a commercially available FET amplifier at 880 MHz with two-tone input and difference-frequency injection. The two spectra are shown in Fig. 14 and illustrate an  $IM_3$  improvement of 48 dB to give a  $C/I$  of 59 dB. Similarly, the bench behavior of an amplifier has been examined at 880 MHz with a two-tone input with the difference-frequency technique. The initial output spectrum and the improved output spectrum are shown in Fig. 15, which shows a reduction in  $IM_3$  by 20 dB and in fifth-order intermodulation product ( $IM_5$ ) by over 30 dB.

The bench behavior of an amplifier at 880 MHz has also been investigated with a three-tone input using the difference-frequency technique. Fig. 16 shows the spectrum both with and without the injection of the difference frequency. An improvement of 17 dB in  $IM_3$  is obtained. An earlier paper by Moazzam

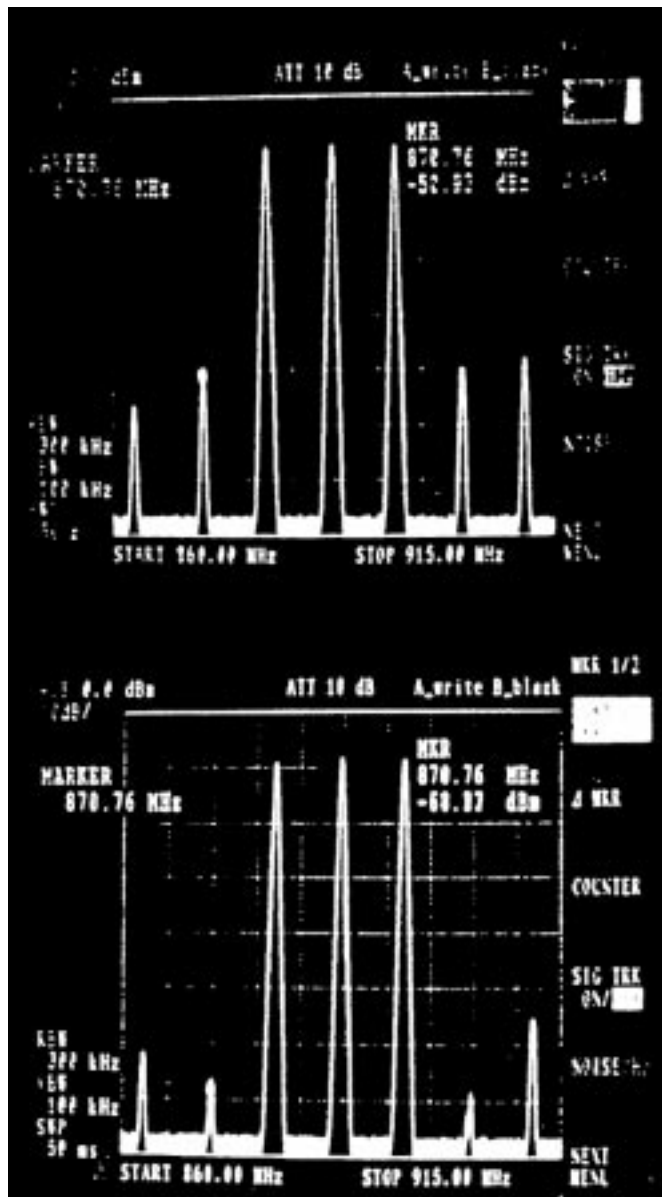

Fig. 16. Three-tone response of 880-MHz amplifier without (upper) and with (lower) injection of difference frequency showing IM3 improvement of 17 dB.

and Aitchison [5] suggested that the second harmonic signal required for the second harmonic technique could be obtained from the drain and fed back through a bandpass filter (BPF) and, after adjustment of phase and amplitude, could be injected into the gate to produce the same beneficial reduction in IM3, as described above. Jing *et al.* [6] have recently applied this technique to a two-stage amplifier at 1.8 GHz. The input to the amplifier was a  $\pi/4$ -DQPSK signal. The spectral regrowth was measured with and without the injected second harmonic. Addition of the second harmonic at the correct phase and amplitude gave a 15-dB reduction in ACPR. Joshin *et al.* [7] also used this technique for wide-band CDMA at 1.95 GHz with an HBT power amplifier and obtained a 7-dB reduction in ACPR for a chip rate of 4.096 Mcps with a 5-MHz offset at 27-dBm power output.

More recently, Yang and Kim [8] have applied the frequency-difference technique to a 2.15-GHz FET amplifier in which the difference frequency is fed forward to the drain at the

correct level to produce IM3 reduction. The technique produced an 18-dB improvement in a two-tone IM3 measurement and an improvement of 10 dB in ACPR with a CDMA signal. Jenkins and Khanifar [9] have also used the difference-frequency technique with an input of four sinusoids to a 1.8-GHz amplifier with a 1-dB gain compression output of 35 dBm. The average improvement in IM3 was 17.3 dB.

## V. CONCLUSIONS

In this paper, it has been shown that the intermodulation performance of an amplifier can be improved by the addition of the second harmonic of the input signal or the difference frequencies between the spectral components of the input signal to the amplifier input. Theory, simulation, and practice support this conclusion. The difference-frequency technique is superior to the second harmonic technique since both the first and the second kind of intermodulation products are reduced, whereas the second harmonic technique reduces only the first kind.

Practical results using a two-tone input with the second harmonic technique show a reduction in IM3 by 43 dB and a corresponding improvement in ACPR of 6 dB in an 835-MHz HBT amplifier. In a MESFET amplifier at 880 MHz, a 48-dB improvement was obtained. However, with a more complex input signal, the benefit is less impressive because only intermodulation products of the first kind are reduced by second harmonic injection.

The difference-frequency technique reduced the third- and fifth-order intermodulation products by 20 and 30 dB, respectively, in a MESFET amplifier at 880 MHz. These practical results are in general agreement with simulation results.

## REFERENCES

- [1] C. S. Aitchison, "The current status of RF and microwave amplifier intermodulation performance," in *IEEE Radio Freq. Integrated Circuits Symp.*, Boston, MA, June 2000, pp. 113–116.
- [2] M. R. Moazzam and C. S. Aitchison, "The reduction of third order intermodulation product in microwave amplifiers," in *IEE Coll. Solid-State Power Amplification Generation Dig.*, Jan. 1996, pp. 7/1–7/5.
- [3] M. Modeste, D. Budimir, M. R. Moazzam, and C. S. Aitchison, "Analysis and practical performance of a difference frequency technique for improving the multicarrier IMD performance of RF amplifiers," in *IEEE MTT-S Technol. Wireless Applicat. Symp. Dig.*, Vancouver, BC, Canada, Feb. 1999, pp. 53–56.
- [4] F. Ali, M. R. Moazzam, and C. S. Aitchison, "IMD elimination and APCR improvement for a 800 MHz HBT MMIC power amplifier," in *IEEE RFIC Symp. Dig.*, Baltimore, MD, June 1998, pp. 69–71.
- [5] M. R. Moazzam and C. S. Aitchison, "A low third order intermodulation amplifier with harmonic feedback circuitry," in *IEEE MTT-S Int. Microwave Symp. Dig.*, vol. 2, 1996, pp. 827–830.
- [6] D. Jing, W. S. Chan, S. M. Li, and C. W. Li, "New linearization method using interstage second harmonic enhancement," *IEEE Microwave Guided Wave Lett.*, vol. 8, pp. 402–404, Nov. 1998.
- [7] K. Joshin, Y. Nakasha, T. Iwai, T. Miyashita, and S. Ohara, "Harmonic feedback circuit effects on intermodulation products and adjacent channel leakage power in HBT power amplifiers for 1.95 GHz wide-band CDMA cellular phones," *IEICE Trans. Electron.*, vol. E 82-C, no. 5, pp. 725–729, May 1999.
- [8] Y. Yang and B. Kim, "A new linear amplifier using low-frequency second-order intermodulation component feedforwarding," *IEEE Microwave Guided Wave Lett.*, vol. 9, pp. 419–421, Oct. 1999.
- [9] W. J. Jenkins and A. Khanifar, "A multicarrier amplifier with low third-order intermodulation distortion," in *IEEE MTT-S Int. Microwave Symp. Dig.*, vol. 3, Boston, MA, June 2000, pp. 1515–1518.



**Colin S. Aitchison** (A'87–SM'90–F'94) received the B.Sc. degree from Imperial College, London, U.K., in 1955.

He has been with Philips Research Laboratories, Chelsea College, University of London, ERA Technology, and Brunel University. He was Professor and Head of Department at both Chelsea College and Brunel University, where he was also Dean of the Faculty of Technology. He is currently a Professor of microwave engineering at the University of Surrey, Guildford, U.K., where he is involved with research on microwave circuits and the microwave-photonics interface. He has authored or co-authored approximately 170 research papers in this area.

Prof. Aitchison is a Fellow of the Institution of Electrical Engineers (IEE), U.K.



**Modeste Mbabele** (S'98–M'01) was born in Libreville, Gabon. He received the B.Sc. degree in electronic engineering from Newport University, Newport, CA, in 1994, and the M.Sc. and Ph.D. in communication engineering from Brunel University, Uxbridge, U.K., in 1996 and 2000, respectively.

Since 2000, he has been engaged in research on microwave photonics at the University of Surrey, Guildford, U.K. His current areas of interest are microwave circuits, components, and microwave semiconductor devices.



**M. Reza Moazzam** (S'88–M'90–SM'96) received the B.Eng. and M.Sc. degrees from Tehran University, Tehran, Iran, and the Ph.D. degree from the University of London, London, U.K.

From 1987 to 1992, he was with King's College, University of London. From 1992 to 1994, he was with Brunel University, Uxbridge, U.K. During that time, he was initially involved with research on microwave active filter topics and then on high-efficiency microwave amplifiers and their linearization techniques. From 1994 to 1997, he was a Senior

Lecturer at the University of Westminster, London, U.K. From 1997 to 2000, he was with the Research and Development Center, Nokia Mobile Phones, San Diego, CA, where he was involved in design and implementation of CDMA mobile phones. He is currently a member of the Technical Staff, Siemens Information and Communication, San Diego, CA, where he is involved with time-division multiple-access (TDMA) and generalized scattering matrix (GSM) mobile phone developments. He also teaches two RF courses at the University of California at San Diego (UCSD), La Jolla. He has authored or co-authored over 40 papers and holds two patents in microwave subjects.



**Djuradi Budimir** (S'89–M'92) was born in Serbian Krajina (formerly Yugoslavia). He received the Dipl.Eng. and M.Sc. degrees in electronic engineering from the University of Belgrade, Belgrade, Serbia, and the Ph.D. degree in electronic and electrical engineering from the University of Leeds, Leeds, U.K., in the area of waveguide filters for microwave and millimeter-wave applications.

In March 1994, he joined the Department of Electronic and Electrical Engineering, Kings College, University of London, London, U.K., as a Post-Doctoral Research Fellow, during which time he was supported by two Engineering and Physical Sciences Research Council (EPSRC) contracts. Since January 1997, he has been with the Department of Electronic Systems, University of Westminster, London, U.K. He owns DBFilter, which is a software and consulting company. He has authored or co-authored over 80 technical papers in the field of microwave and millimeter-wave computer-aided design (CAD). He also authored *Generalized Filter Design by Computer Optimization* (Norwood, MA: Artech House, 1998) and the software and users' manual *EPFIL-Waveguide E-Plane Filter Design* (Norwood, MA: Artech House, 2000). His research interests include analysis and design of hybrid and monolithic microwave integrated circuits, such as amplifiers and filters, dielectric resonator filters for modern communications systems, the application of numerical methods to the electromagnetic field analysis of passive microwave and millimeter-wave circuits, and the design of waveguide filters and multiplexing networks for microwave and millimeter-wave applications. He is a reviewer for the *IEE Electronic Letters* and *Proceedings of the IEE—Microwaves, Antennas, and Propagation*.

Dr. Budimir has served on the Technical Program Committee for TELSIKS (1997, 1999, 2001). He is a reviewer for the IEEE MICROWAVE AND GUIDED WAVE LETTERS.

**Fazal Ali** (S'82–M'83–SM'90–F'99), photograph and biography not available at time of publication.