

# Reduced Complexity Soft MMSE MIMO Detector Architecture

Kiarash Amiri, (*ECE Department, Rice University, Houston, TX, USA; kiaa@alumni.rice.edu*);  
 Chris Dick, (*Wireless Systems Engineering, Xilinx, San Jose, CA, USA; chris.dick@xilinx.com*);  
 Raghu Rao, (*Wireless Systems Engineering, Xilinx, Austin, TX, USA; raghu.rao@xilinx.com*);  
 Joseph R. Cavallaro, (*ECE Department, Rice University, Houston, TX, USA; cavallar@rice.edu*)

**Abstract**—Computing the soft LLR values in MMSE receivers of MIMO systems requires a very large complexity. In this paper, we propose a reduced complexity soft MMSE detector for MIMO systems. We use different complexity reductions techniques and propose an architecture based on the new reduced-complexity method. We also compare the complexity and show more than 2x complexity reduction using this method. We present complexity/performance tradeoffs to demonstrate the efficacy of our techniques. More importantly, these techniques give the receivers the flexibility to choose how accurately they perform the detection based on the available resources.

## I. INTRODUCTION

Multiple-input multiple-output (MIMO) systems have been one of the main research topics in wireless communication for their capability of achieving very high spectral efficiencies [1] as well as offering more robustness to mitigate the inherent fading in wireless channels. However, any effort to design a MIMO-based transceiver needs to address the detection problem. The complexity of the optimum detector, i.e. maximum-likelihood (ML) receiver, grows exponentially as more antennas are used at the transmitter, and as higher order modulation schemes are adopted. One of the alternatives to the ML receiver is the MMSE receiver [2] that follows a linear complexity and does not require a variable complexity that would occur in the sphere detection [3], [4].

The MMSE receiver, however, still requires considerably large amount of computational resources, which increases the power consumption in the handset devices. Therefore, it is essential to reduce the complexity of the MMSE receiver while taking advantage of its fixed complexity. In this paper, we propose a reduced complexity soft MMSE detector for MIMO systems. We use different complexity reduction techniques and propose an architecture based on the new reduced-complexity method. We also compare the complexity and show more than two times complexity reduction using this method. Moreover, we present the complexity/performance tradeoff comparisons. These results show that, depending on how much resources are available in the receiver, the receiver can choose the accuracy of the detection while ensuring a fixed complexity. In other words, for the cases where limited resources are available in the receiver, the receiver could choose to perform the "reduced-complexity" method, which significantly reduces the complexity and resource utilization, with limited performance loss.

This paper is organized as follows: Section II covers the system model definition, and the MMSE scheme is described in section III. The proposed reduced complexity soft MMSE receiver is discussed in section IV. The computational complexity and hardware architecture of this technique is studied in section V. Monte-carlo simulation results of this scheme are presented in section VI. Finally, the paper concludes with section VII.

## II. SYSTEM MODEL

We consider a MIMO system with  $M_T$  transmit and  $M_R$  receive antennas. Blocks of information bits of length  $N_m$  are each encoded with a Turbo encoder with rate  $R$ . At the output of the Turbo encoder, every  $\log w$ -length bit sequence is mapped to one of the modulation symbols of a complex-valued constellation  $\Omega$  of the order  $w = |\Omega|$ , and average power constraint of  $E[x_i^2] = 1$ . The modulation symbols are multiplexed across the  $M_T$  transmit antennas and form the transmit vector  $\mathbf{x} = [x_1, x_2, \dots, x_{M_T}]^T$ . The input-output channel model is captured by

$$\mathbf{y} = \mathbf{H}\mathbf{x} + \mathbf{n} \quad (1)$$

where  $\mathbf{H}$  is the complex-valued  $M_R \times M_T$  channel matrix with independent elements, each drawn from a circularly symmetric Gaussian random distribution with zero mean and variances of  $\sigma^2$ , where:

$$\sigma^2 = \sqrt{\frac{\text{SNR}}{M_T}}$$

The  $\mathbf{n}$  vector is the circularly symmetric complex additive white Gaussian noise vector of size  $M_R$ , with each of their elements chosen from a complex symmetric Gaussian variable  $\mathcal{CN}(0, 1)$ . The  $\mathbf{y} = [y_1, y_2, \dots, y_{M_R}]^T$  is the  $M_R$ -element received vector.

## III. SOFT MMSE RECEIVER (S-MMSE)

In this section, we present the soft MMSE receiver. As shown in [5], in order to detect the  $x_j$  symbol,  $j = 1, \dots, M_T$ , the expected values of the transmitted symbols are computed using the LLR values,  $L_C$ , from the channel decoder:

$$\begin{aligned} \tilde{x}_j &= \sum_{\tilde{x} \in \Omega} \tilde{x} P(x_j = \tilde{x}) \\ &= \sum_{\tilde{x} \in \Omega} \tilde{x} \prod_{l=1}^{\log w} [1 + \exp(-\{\tilde{x}\}_l \cdot L_C(b_{l,j}))]^{-1} \quad (2) \end{aligned}$$

TABLE I  
COMPLEXITY COUNT OF DIFFERENT OPERATIONS IN MMSE RECEIVER.

	Multiplication	Addition
$C_{CPP}(M_T)$	$\gamma \cdot (5.5M_T^3 + 2M_T^2 + 0.5M_T + 4M_T + 4M_T^2)$	$\theta \cdot (5M_T + 5M_T^2)$
$C_{MIMO}(M_T)$	$\gamma \cdot (4M_T(M_T(M_T - 1) + M_T))$	$\theta \cdot (2(M_T - 1) + 5(M_T - 1 + M_T^2))$
$C_{SMC}(M_T, w)$	$\gamma \cdot (M_T((w \log w) + 2w))$	$\theta \cdot (M_T((w \log w) + 2w))$
$C_{LLR}(M_T, w, I)$	$\gamma \cdot (M_T w \log w)$	$\theta \cdot (2M_T w \log w + \text{sign}(I - 1) \{M_T(w - 1) \log w\})$
$C_{Decoder}(T_I, N_m)$	-	$\theta \cdot (44T_I N_m)$

	Compare-Select
$C_{CPP}(M_T)$	-
$C_{MIMO}(M_T)$	-
$C_{SMC}(M_T, w)$	-
$C_{LLR}(M_T, w, I)$	-
$C_{Decoder}(T_I, N_m)$	$\beta \cdot (39T_I N_m)$

where  $b_{l,j}$  is the  $l$ -th bit in the  $x_j$  symbol. Note that for the first outer iteration, the vector  $L_C$ 's are all equal to zero since no channel decoding has been done yet.

The vector of these mean values are formed, while replacing the current symbol with zero:

$$\tilde{\mathbf{x}}_j = [\tilde{x}_1, \dots, \tilde{x}_{j-1}, 0, \tilde{x}_{j+1}, \dots, \tilde{x}_{M_T}]^T \quad (3)$$

Performing a soft cancellation using the vector of Eq (3) is then done so that the effect of the other modulation symbols are cancelled:

$$\tilde{\mathbf{y}}_j = \mathbf{y} - \mathbf{H}\tilde{\mathbf{x}}_j \quad (4)$$

The MMSE filter is applied then to obtain:

$$\tilde{z}_j = \mathbf{w}_j^H \tilde{\mathbf{y}}_j \quad (5)$$

where, as shown in [5], the filter coefficient are computed according to

$$\mathbf{w}_j = (\mathbf{H}\Delta_j\mathbf{H}^H + \mathbf{I})^{-1}\mathbf{H}\mathbf{e} \quad (6)$$

where

$$\Delta_j = \text{cov}\{\mathbf{x}_j - \tilde{\mathbf{x}}_j\} \quad (7)$$

is the covariance matrix of the  $\mathbf{x}_j - \tilde{\mathbf{x}}_j$  random vector.

Finally, the output LLR values,  $L_M$ , are computed according to

$$L_M(b_i) = \log \frac{P(b_i = +1|z_j)}{P(b_i = -1|z_j)} - \log \frac{P(b_i = +1)}{P(b_i = -1)}$$

$$= \log \frac{\sum_{\mathbf{x}^+ \in \mathcal{S}_{i,j}^+} \exp\left(-\frac{\|z_j - \mu_j \mathbf{x}^+\|^2}{\eta_j^2} + \sum_{k=1, k \neq i}^{\log w} \{x_j^+\}_k \cdot \frac{L_C(b_k)}{2}\right)}{\sum_{\mathbf{x}^- \in \mathcal{S}_{i,j}^-} \exp\left(-\frac{\|z_j - \mu_j \mathbf{x}^-\|^2}{\eta_j^2} + \sum_{k=1, k \neq i}^{\log w} \{x_j^-\}_k \cdot \frac{L_C(b_k)}{2}\right)} \quad (8)$$

where

$$\mu_j = E\{z_j|x_j\} \quad (9)$$

$$\eta_j^2 = \text{var}\{z_j\} = \mu_j - \mu_j^2 \quad (10)$$

are the mean and variance of  $z_j$ .

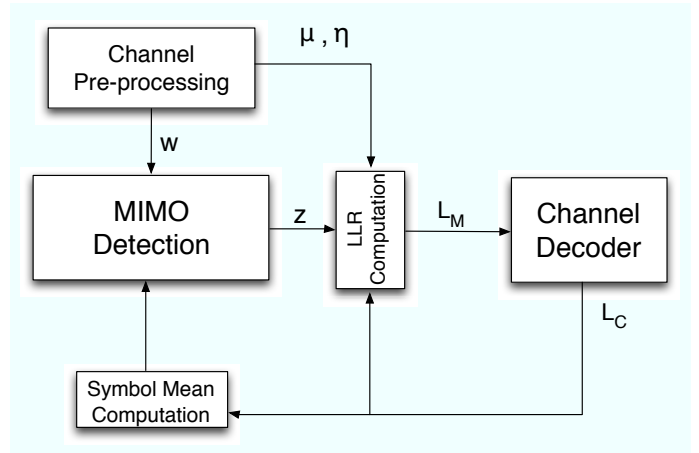

Fig. 1. The architecture for the reduced complexity soft MMSE receiver.

The  $L_M$  LLRs are then passed to the Turbo decoder to perform the channel decoding and generate the  $L_C$  for the next outer iteration. Similar procedure is repeated for  $I$  outer iterations, after which the decoder output is considered the final decoded bits. Figure 1 illustrates the architecture for the MMSE receiver.

#### IV. PROPOSED REDUCED COMPLEXITY SOFT MMSE RECEIVER (RC-MMSE)

In this section, we propose three techniques to reduce the complexity of the soft MMSE receiver. It is important to emphasize that while some of these techniques were known in other applications, they have not been collectively applied to the MMSE receivers in MIMO systems.

##### A. Covariance Matrix $\Delta_j$

The covariance matrix  $\Delta_j$  has to be updated in (7) for every new iteration. Therefore, the MMSE weights  $\mathbf{w}_j$  need to be re-computed for every new iterations. In [6], the authors have proposed using fixed covariance matrix for single antenna single carrier systems. In order to reduce the complexity of computing the MMSE weights, we propose using the first

iteration covariance matrix throughout the  $I$  iterations, i.e.  $\Delta_j = \mathbf{I}$ , where  $\mathbf{I}$  is the identity matrix.

Note that the feedback link modifies the values of the covariance matrix,  $\Delta_j$ , and LLRs,  $L_{MS}$  in each other outer iterations. Therefore, with this approximation, the feedback link still improves the performance through updating the LLR values.

### B. Max-log Approximation

In order to avoid using the look-up tables for computing the exp functions of (8), we use the Max-log approximation [7]. The Max-log approximation states that

$$\log(\exp(a) + \exp(b)) = \max(a, b) + \log(1 + \exp(-|a - b|))$$

which can be generalized to

$$\log\left(\sum_{i=1}^N \exp(a_i)\right) = \max(a_i) + f(a_1, \dots, a_N)$$

where  $f$  is a correction that depends on the mutual distances between the  $a_i$ s.

We will, therefore, use the following approximation:

$$\log\left(\sum_{i=1}^N \exp(a_i)\right) \simeq \max(a_i).$$

Using this approximation also saves the resources required for computing the summations of Eq (8):

$$L_M(b_i) \simeq \frac{1}{2} \max_{\mathbf{x}^+ \in \mathcal{S}_{i,j}^+} \left( \frac{-\|z_j - \mu_j \mathbf{x}^+\|^2}{\eta_j^2} + \sum_{k=1, k \neq i}^{\log w} \{x_j^+\}_k \cdot \frac{L_C(b_k)}{2} \right) - \frac{1}{2} \max_{\mathbf{x}^- \in \mathcal{S}_{i,j}^-} \left( \frac{-\|z_j - \mu_j \mathbf{x}^-\|^2}{\eta_j^2} + \sum_{k=1, k \neq i}^{\log w} \{x_j^-\}_k \cdot \frac{L_C(b_k)}{2} \right) \quad (11)$$

### C. Using $l-1$ norm

Using the squared form of the norm  $-\|z_j - \mu_j \mathbf{x}^-\|^2$  in (11) requires performing several multiplications or squaring operations for every single bit. Therefore, we propose using the  $l-1$  norm, i.e.  $-\|z_j - \mu_j \mathbf{x}^-\|$ , instead. This approximation results in less accurate computation of the distance norm, however, since the relative values of the norms determine the LLR value, it has little impact on the final accuracy of the LLR estimate and the overall performance.

## V. COMPLEXITY ANALYSIS AND HARDWARE ARCHITECTURE

Keeping in mind that each complex multiplier corresponds to four real-valued multipliers and two real-valued adders, and that every complex adder corresponds to two real-valued adders, the complexity of different units of Figure 1 is given in Table I where  $\text{sign}(I - 1)$  is used to ensure the last set of computations are done for outer iterations  $I > 1$ , and is equal to:

$$\text{sign}(t) = \begin{cases} 1 & t \geq 1 \\ 0 & \text{otherwise} \end{cases} \quad (12)$$

Moreover, we use  $\theta$ ,  $\beta$  and  $\gamma$  to represent the hardware-oriented costs for one adder, one compare-select and one multiplication operation, respectively. Based on FPGA and ASIC

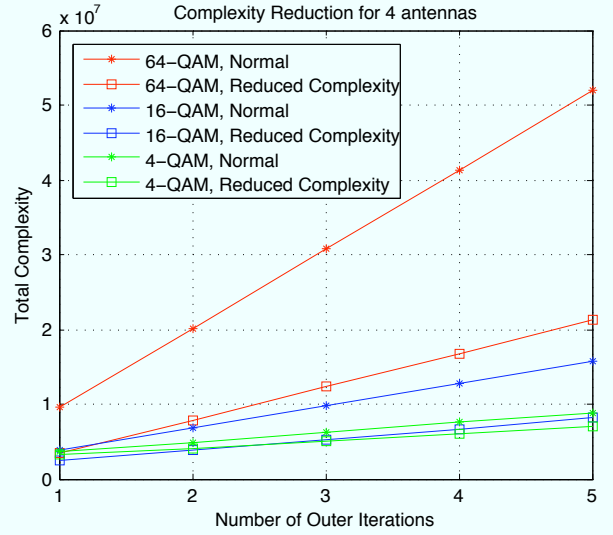

Fig. 2. The total computation count for a  $4 \times 4$ ,  $\{4, 16, 64\}$ -QAM system for different numbers of outer iterations.

estimates, we choose  $\theta = 1$ ,  $\beta = 1$  and  $\gamma = 10$  throughout this paper. The number of inner Turbo decoder iterations are denoted by  $T_I$  and the information bit sequence length is  $N_m$ . Also, in order to compute the resources required to perform the QR decomposition in the Channel Pre-processing Unit, we assumed the modified Gram-Schmidt QR decomposition.

Therefore, the total computation is given by

$$C_{Total} = \frac{N_m}{R \cdot M_T \log w} \cdot \{C_{CPP}(M_T) + (I + 1) \cdot C_{MIMO}(M_T) + I \cdot C_{SMC}(M_T, w) + C_{LLR}(M_T, w, I) + I \cdot C_{LLR}(M_T, w, I)\} + (I + 1) \cdot C_{Decoder}(T_I, N_m) \quad (13)$$

where  $I = 0$  corresponds to no outer iteration and feedback,  $I = 1$  correspond to one outer iteration, etc.

Figure 2 compares the total complexity of the conventional soft MMSE receiver of section III with the RC-MMSE receiver of section IV for 4 transmit antennas, codeword of 1200 length, 8 inner Turbo decoder iterations, and different signal modulations. Also, Figure 3 shows the complexity for different units of the receiver for each outer iteration and for different numbers of antennas. In other words, each of the plots in Figure 3 show the elements of in Eq (13) for each iteration.

## VI. SIMULATION RESULTS

In this section, we present the BER simulation results for a  $4 \times 4$  system using both the conventional soft MMSE receiver and the proposed RC-MMSE receiver. We assume an i.i.d Rayleigh fading channel.

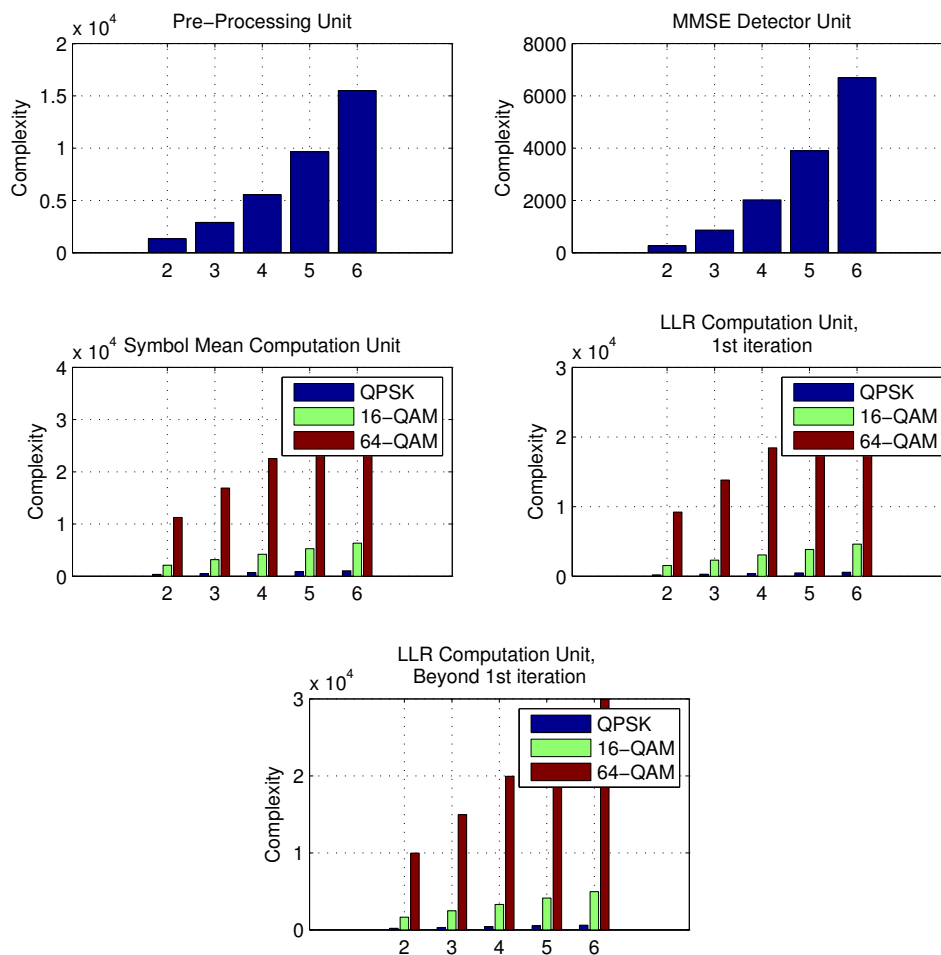

Fig. 3. The computation count for 2 to 6-antenna, {4, 16, 64}-QAM systems for each outer iteration. The horizontal axes correspond to the number of antennas.

Figure 4 shows the BER performance using the conventional MMSE receiver of section III. The number of transmit and receive antennas are equal to 4, and the 4-QAM and 16-QAM modulations are assumed. Figure 5 shows the BER performance for a similar transmission system with the RC-MMSE receiver. Note that in the case of 4-QAM modulation, there is between 0.5 and 1 dB BER performance loss at  $\text{BER} = 10^{-4}$  for different outer iterations, and in the case of 16-QAM modulation, the BER performance loss is between 1 and 1.5 dB.

## VII. CONCLUSION

In this paper, we proposed a reduced complexity soft MMSE (RC-MMSE) detector for MIMO systems. We used different complexity reductions techniques and proposed an architecture based on the new reduced-complexity method. This method provided more than two times complexity reduction. We

presented the complexity/performance tradeoff comparisons, and demonstrated that for the cases where limited resources are available in the receiver, the receiver could choose to perform the "reduced-complexity" method, which significantly reduces the complexity and resource utilization, with limited performance loss.

## VIII. ACKNOWLEDGEMENT

This work was supported in part by Xilinx, and by NSF under grants CCF-0541363, CNS-0551692, EECS-0925942, CNS-0923479, and CNS-0619767.

## REFERENCES

- [1] G. Foschini, "Layered space-time architecture for wireless communication in a fading environment when using multiple antennas," *Bell Labs. Tech. Journal*, vol. 2, 1996.
- [2] B. Lu, G. Yue and X. Wang, "Performance analysis and design optimization of LDPC-Coded MIMO OFDM systems," *IEEE Trans. on Signal Processing*, vol. 52, no. 2, Feb. 2004.

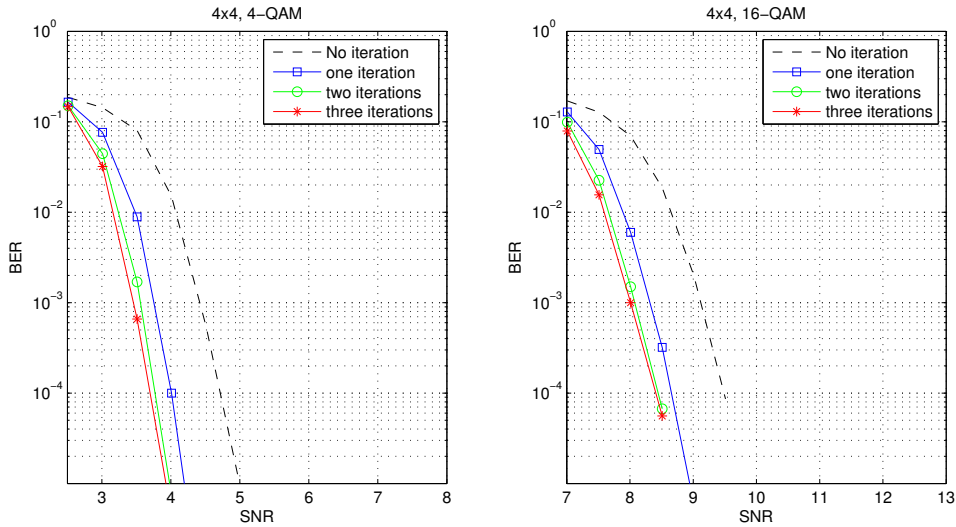

Fig. 4. The BER performance for a  $4 \times 4$ ,  $\{4, 16\}$ -QAM system using the original soft MMSE receiver.

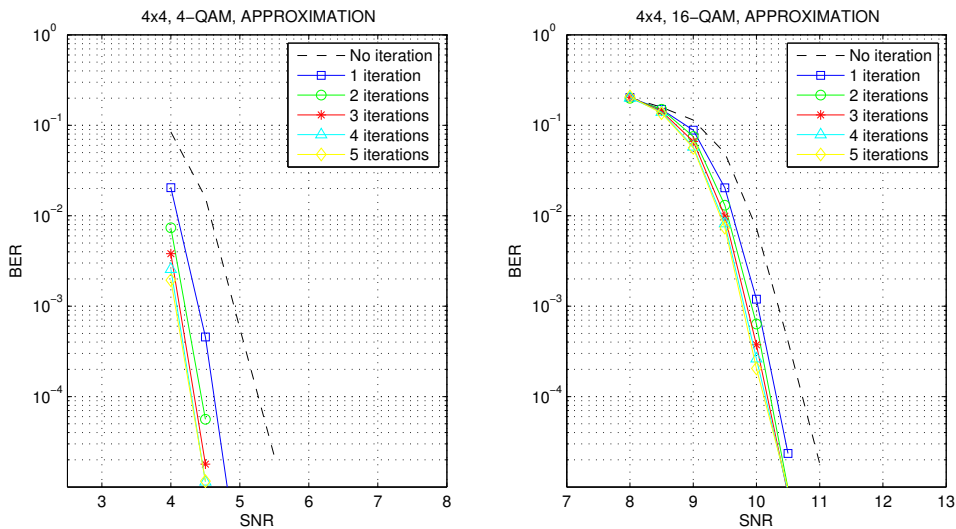

Fig. 5. The BER performance for a  $4 \times 4$ ,  $\{4, 16\}$ -QAM system using the proposed Reduced Complexity MMSE receiver.

- [3] A. Burg, M. Borgmann, M. Wenk, M. Zellweger, W. Fichtner and H. Bolcskei, "VLSI implementation of MIMO detection using the sphere decoding algorithm," *IEEE JSSC*, vol. 40, no. 7, pp. 1566–1577, Jul. 2005.
- [4] N. Moezzi-Madani and W. R. Davis, "High-throughput low-complexity MIMO detector based on K-best algorithm," *ACM Great Lake Symposium on VLSI*, pp. 451–456, May 2009.
- [5] B. Lu, G. Yue and X. Wang, "Performance analysis and design optimization of LDPC-coded MIMO OFDM systems," *IEEE Transactions on Signal Processing*, Feb. 2004.
- [6] M. Tuchler, R. Koetter and A. C. Singer, "Turbo equalization: Principles and new results," *IEEE Transactions on Communications*, vol. 50, pp. 754–767, May 2002.
- [7] B. Hochwald and S. ten Brink, "Achieving near-capacity on a multiple-antenna channel," *IEEE Transactions on Communications*, vol. 51, pp. 389–399, Mar. 2003.