

Grassroots Mapping: tools for participatory and activist cartography

by Jeffrey Yoo Warren

B.A. Yale University 2006

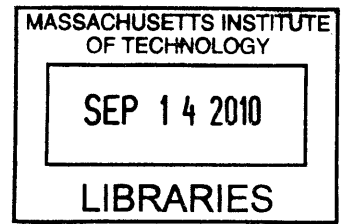

**ARCHIVES**

Submitted to the Program in Media Arts and Sciences,  
School of Architecture and Planning,  
in partial fulfilment of the requirements for the degree of  
Master of Science  
at the MASSACHUSETTS INSTITUTE OF TECHNOLOGY  
September 2010

©2010 Massachusetts Institute of Technology. All rights reserved.

*author:*

A handwritten signature in black ink, appearing to read "JY Warren", written over a horizontal line.

Program in Media Arts and Sciences September 2010

*certified by:*

A handwritten signature in black ink, appearing to read "David Small", written over a horizontal line.

Dr. David Small  
Associate Professor  
Program in Media Arts and Sciences  
Thesis supervisor

*accepted by:*

A handwritten signature in black ink, appearing to read "Pattie Maes", written over a horizontal line.

Prof. Pattie Maes  
Associate Academic Head  
Program in Media Arts and Sciences

# Grassroots Mapping: tools for participatory and activist cartography

*by Jeffrey Warren*

B.A. Yale University 2006

Submitted to the Program in Media Arts and Sciences,  
School of Architecture and Planning,  
in partial fulfilment of the requirements for the degree of  
Master of Science  
at the MASSACHUSETTS INSTITUTE OF TECHNOLOGY  
September 2010

©Massachusetts Institute of Technology 2010. All rights reserved.

## **Abstract**

Geospatial tools and information play an important role in urban planning and policymaking, and maps have diverse uses in legal, environmental, political, land rights, and social arenas. Widespread participation in mapmaking and access to its benefits is limited by obscure and expensive tools and techniques. This has resulted in poor or nonexistent maps for much of the world's population, especially in areas of urban poverty. In particular, public access to recent and high-resolution satellite imagery is largely controlled by government and large industry. This thesis proposes balloon and kite aerial photography as a low-cost and easy to learn means to collect aerial imagery for mapping, and introduces a novel open-source online tool for orthorectifying and compositing images into maps.

A series of case studies where such tools and techniques were used by communities and activists in Lima, Peru and during the 2010 BP oil spill highlight the empowering role broader participation in cartography can play in advocacy, and the potential for increased cartographic literacy to level the playing field in territorial self-determination for small communities. Compared to other efforts to democratize mapmaking, which focus primarily on the presentation and interpretation of existing map data, this project emphasizes participation in the creation of new data at its source — direct imaging of the earth's surface. Accompanying educational materials and workshops with adults and youth, as well as an active online community of participants, have ensured wide adoption of Grassroots Mapping practices.

Thesis supervisor:  
Dr. David Small  
*Associate Professor*  
Program in Media Arts and Sciences

Grassroots Mapping: tools for participatory and activist cartography  
*by Jeffrey Warren*

*Thesis reader:*

---

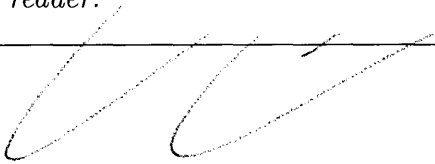

Chris Csikszentmihalyi  
Research Scientist  
Director, Center for Future Civic Media and Computing Culture Group  
MIT Media Lab

Grassroots Mapping: tools for participatory and activist cartography  
*by Jeffrey Warren*

*Thesis reader:*

---

Dr. Mitchel Resnick  
Professor  
Program in Media Arts and Sciences



## Acknowledgements

I am immensely grateful for the help I've received from my colleagues and collaborators in this project. I want to thank both the Design and Information Ecology groups for their humor, criticism and patience. Thanks also to my readers, and especially to Chris Csikszentmihalyi for his support and guidance. Thanks also to the many mappers around the world with whom I have worked, both on coding projects and in reeling in miles of string. These include Carla del Carpio and Manzanita 'A', CEDRO, Escuelab, Shannon Dosemagen, Kris Ansin and others from the Louisiana Bucket Brigade. My thanks go to Stewart Long and Oliver Yeh for pushing the envelope with me, Josh Levinger for asking me if I've done any math, JB Labrune for keeping me critical, and everyone from OpenMapsCaucasus and Coal River Mountain Watch for their willingness to try crazy things. Thanks to Natalie Jeremijenko for her constant energy, criticism, support, and dissatisfaction with the status quo. I am grateful as well for the generosity of members of the Grassroots Mapping mailing list in times of large and small crises, and to everyone who has put in time and effort to make this project possible. Finally, special thanks go to Nadya Peek, my family and my friends for being there for me.

## Contributors

The following organizations offered generous support of the citizen mapping effort in the Gulf of Mexico following the 2010 BP oil spill, in the form of time, money, transportation, and other means. My thanks go out to them on behalf of everyone involved in the oil spill mapping project.

- Louisiana Bucket Brigade
- GonzoEarth
- 1337arts.com
- MIT's Center for Future Civic Media
- The Knight Foundation
- Kris Ansin
- John Norwood
- Adam Boulton
- The Lafourche Parish Port Commission
- DevelopmentSeed
- The Washington Post
- TungstenMonkey Productions/Kristian Hansen
- WebMadeMovies/Brett Gaylor
- Jeff Johnson
- Liz Barry
- The Blue Seals
- Uptown Angler
- All the project's backers on Kickstarter

# Contents

<b>1</b>	<b>Introduction</b>	<b>10</b>
1.1	Defining Grassroots Mapping: tools, practices, or community? . . . . .	10
1.1.1	Uses of aerial imagery . . . . .	11
1.1.2	Grassroots Mapping as pedagogy . . . . .	11
1.1.3	Grassroots Mapping as a community . . . . .	11
1.2	Tools, technologies, and audience . . . . .	12
<b>2</b>	<b>Movements towards a participatory and activist cartography</b>	<b>14</b>
2.1	Experimental geography and radical cartography . . . . .	14
2.2	Geographic Information Systems (GIS) practitioners . . . . .	16
2.2.1	Cartographic ethics . . . . .	17
2.3	Neogeography . . . . .	18
<b>3</b>	<b>Subjectivity in Mapping</b>	<b>20</b>
3.1	The mythical ‘complete map’ . . . . .	20
3.2	A ‘ground truth’ policy for collaborative mapmaking . . . . .	22
3.3	Privacy and mapping, privacy and open geodata . . . . .	22
3.4	Mapping: a tool of empowerment or control? . . . . .	23
3.5	Maps as truth . . . . .	25
3.6	Maps: rhetorical, even tactical . . . . .	27
3.6.1	Activist cartography . . . . .	27
<b>4</b>	<b>The Need for Geospatial Data</b>	<b>28</b>

4.1	Two worlds of mapping . . . . .	28
4.2	Mapping for social change . . . . .	29
4.3	Environmental assessment . . . . .	30
4.3.1	Asset allocation mapping . . . . .	30
4.4	Open geodata and crisis mapping . . . . .	31
4.4.1	Crisis mapping and Ushahidi . . . . .	31
<b>5</b>	<b>State of the Art</b>	<b>33</b>
5.1	Participatory GIS for Development . . . . .	33
5.2	Web mapping . . . . .	34
5.2.1	Google Maps and proprietary data . . . . .	35
5.2.2	OpenStreetMap . . . . .	36
5.2.3	The modern open-source geostack . . . . .	36
5.2.4	Humanitarian OSM Team . . . . .	37
5.3	Orthorectification . . . . .	39
5.3.1	Map Warper . . . . .	39
5.3.2	GonzoEarth and manual stitching with Adobe Photoshop . . . . .	40
5.4	Aerial imaging with low-cost tools . . . . .	40
5.4.1	DIYDrones.com and the T3 competition . . . . .	41
<b>6</b>	<b>The Grassroots Mapping tool chain</b>	<b>42</b>
6.1	Balloon and Kite Aerial Mapping . . . . .	42
6.1.1	Balloon mapping . . . . .	42
6.1.2	Kite mapping . . . . .	44
6.1.3	Camera and intervalometer . . . . .	45
6.1.4	Enclosures and suspensions . . . . .	47
6.2	Map processing and publication . . . . .	47
6.2.1	Web-based orthorectification and warping . . . . .	48
6.2.2	Cartagen Knitter . . . . .	48
6.2.3	Rubbersheeting . . . . .	49

6.2.4	Cartagen: an alternative architecture for digital maps . . . . .	50
6.2.5	Architectural advantages of the Cartagen framework . . . . .	51
6.3	An iterative and collaborative approach to tool design . . . . .	52
<b>7</b>	<b>Case Study: Grassroots Mapping in Lima, Peru</b>	<b>54</b>
7.1	Introduction . . . . .	54
7.1.1	The Other Path: Lima's history of informal settlement . . . . .	55
7.2	Mapping with Juan Pablo II . . . . .	56
7.3	Mapping with San Ignacio Loyola . . . . .	61
7.4	Mapping with Cantagallo . . . . .	62
7.5	Evaluation . . . . .	65
7.5.1	Needs (Re)assessment . . . . .	66
<b>8</b>	<b>Case Study: Citizen mapping of the BP oil spill</b>	<b>69</b>
8.1	Grassroots mapping in crisis response . . . . .	69
8.2	Comparing Grassroots Maps of the spill to other sources . . . . .	70
8.3	Independent monitoring and media blackout . . . . .	71
8.4	Adoption and sustainability . . . . .	71
8.4.1	Workshops and trainings . . . . .	74
8.4.2	Collaborations . . . . .	74
8.4.3	Costs and funding model . . . . .	75
8.5	Image processing and map stitching . . . . .	76
8.6	Overflights and a broader data strategy . . . . .	78
8.7	Integration with Ushahidi . . . . .	78
8.8	Documentation . . . . .	79
8.8.1	Analysis of data collected . . . . .	79
8.9	Licensing and data use . . . . .	80
<b>9</b>	<b>Evaluation</b>	<b>83</b>
9.1	Validity in openly ideological research . . . . .	84
9.2	Comparison with existing techniques . . . . .	87

9.3	Quantitative evaluation . . . . .	88
9.3.1	Spatial resolution . . . . .	88
9.3.2	Temporal resolution . . . . .	90
9.3.3	Spectral resolution . . . . .	91
<b>10</b>	<b>Conclusions and future work</b>	<b>92</b>
10.1	Ongoing uses of Grassroots Mapping tools . . . . .	92
10.1.1	Activist mapping with Coal River Mountain Watch . . . . .	92
10.1.2	A Grassroots Mapping collaboration in Georgia . . . . .	93
10.2	Outreach . . . . .	94
10.3	Illustrated Guides . . . . .	95
10.4	Conclusions . . . . .	95
<b>A</b>	<b>Maps</b>	<b>97</b>
A.1	Maps from Lima, Peru . . . . .	97
A.2	Maps from the 2010 BP Oil Spill . . . . .	97
A.3	Maps from Georgia . . . . .	97
<b>B</b>	<b>Illustrated Guide to Grassroots Mapping</b>	<b>98</b>
<b>C</b>	<b>Guides and checklists to Grassroots Mapping for the BP Oil Spill</b>	<b>104</b>

# Chapter 1

## Introduction

### 1.1 Defining Grassroots Mapping: tools, practices, or community?

Exactly what makes up the Grassroots Mapping project? Is it a body of code, available under an open-source MIT license at <http://github.com/jywarren/cartagen>? Is it a set of mapping practices, or tools, which have been employed in Lima, Peru, or Rio de Janeiro? Or is it a community of practitioners and the web site, wiki, and mailing list which tie them together?

Fundamentally this project attempts to make mapping easier for lay users, in order to broaden participation in cartography. Throughout much of the world, maps can be seen as a tool of the state and of industry to express control over world we live in. By simplifying the means to create maps, from the data gathering through the editing and publication of digital and print maps, the tools and techniques I have created are designed to further democratize cartography. In turn, it is hoped that the ability of a wider public to make maps at a reasonable cost will empower bottom-up cartographic activism and circumvent the current power structure of mapmaking.

The core of the Grassroots Mapping project is the *application* of a novel combination of technologies to specific communities. These technologies consist of low-cost aerial imaging techniques using balloons and kites, and a novel online tool for stitching the resulting imagery into maps. The success of these tools is due to the effort and faith of the organizations and individuals who were willing to adopt these new and unfamiliar tools, and who saw their potential for use in their communities in Lima, Peru, and the oil spill crisis on the coast of the Gulf of Mexico. This includes Carla del Carpio of Manzanita 'A' and Ernesto Fernandez of Centro de Información y Educación para la Prevención del Abuso de Drogas (CEDRO), both in Lima, Peru, and Daniel Miracle and others from Escuelab, also in Lima. It includes Kris Ansin, Shannon Dosemagen, and Anne Rolfes of the Louisiana Bucket Brigade in New Orleans. It also includes the dozens of participants who tirelessly flew kites and balloons, and untangled and wound miles of string day after day. Perhaps most importantly, the tools grew and evolved in response to sustained use by participants, and with the input and collaboration of those who used them.

### 1.1.1 Uses of aerial imagery

Participants in the project have made maps for diverse purposes, including environmental monitoring, tenure rights, journalism, and commercial use. Many maps were created in youth workshops emphasizing hands-on learning and community planning, and the tools' unique ability to produce on-demand maps was explored in crisis situations and areas of conflict. Due to their low cost, the techniques have potential for even broader use in asset mapping in low-income or developing areas, and local-level urban planning. The ability to see one's home from a new perspective can initiate thought and discussion about community, environment, and social issues. By engaging with and teaching local communities to use the tools, mapping has taken on more personal relevance than efforts which characterize themselves as remote sensing — efforts which treat people as data and gloss over the human side of cartography.

### 1.1.2 Grassroots Mapping as pedagogy

To facilitate widespread adoption, the project evolved to include a variety of teaching materials, printed guides, online videos, and workshops, both by myself and by the diverse collaborators who took ownership of the tools. These materials addressed a broad range of audiences, from 10-15 year olds in Lima, Peru to environmental activists in West Virginia and Kentucky. This documentation evolved as I collaborated with and instructed participants in dozens of workshops over the past year, and include a project wiki, a blog on which participants document their work, videos, and a mailing list where new ideas and projects are discussed and critiqued.

### 1.1.3 Grassroots Mapping as a community

Ultimately, even the digital tools, including the Cartagen map rendering framework and the Cartagen Knitter, a tool for orthorectifying aerial imagery, were built with assistance and support of colleagues and contributors in the broader mapping community. That this has become the norm in technology projects does not detract from the fact that much of this work would have been impossible without such contributions, and that one of the greatest strengths of this project has been its development in collaboration with communities which have specific needs.

Building tools is unlike developing more abstract technologies in that to be successful, a series of compromises and pragmatic decisions must guide the design process, as well as continuous communication with an audience of users. The Grassroots Mapping project has evolved in response to these needs and should be exam-



**Figure 1.1:** Student participants in a Grassroots Mapping workshop in Samtredia, Georgia

**Table 1.1:** Grassroots Mapping workflow

Capture	Orthorectification	Publication
2-3 people can map several square km in 1 day	Sorting photos can take >1 hour, stitching up to 1 day	Export from Cartagen Knitter generates a TMS or printable GeoTiff; only web access is needed.

ined in the context of the specific uses it has attempted to address, rather as an isolated or purely academic work.

## 1.2 Tools, technologies, and audience

The tools developed as part of the Grassroots Mapping project address the needs of both committed enthusiasts who need powerful and efficient mapping technology, as well as those who have little experience and expertise but need simple and direct tools to make maps. Therefore, some of the tools, while being simple to use, are intended for ‘power users’ or those technically fluent in writing and editing code. The Cartagen framework falls under this category. Other tools, such as the balloon and kite platforms for capturing aerial imagery, are intended for a wider audience, as is the Cartagen Knitter, a specific application of the Cartagen framework. A description of the various tools follows.

The Grassroots Mapping Kit can be used to capture original aerial imagery, process and stitch the results, and publish digital and print maps. This section focuses on the framing, intent, and audience of the necessary tools. A technical discussion of the tools can be found in Chapter 6.

Briefly, map-makers visit the site they intend to map, bringing with them a kite, a balloon, a helium tank, a digital camera, and a minimum of 200 meters of string, along with an assortment of other materials. Attaching the camera to the tethered balloon or kite, they capture imagery by setting up the camera to automatically take pictures on a 1-10 second cycle and raising it to between 200 and 2000 meters in altitude, in accordance with local regulations. The map-makers reel in the tether to recover the camera and, using a web-enabled computer, upload the best imagery to the Cartagen Knitter web site.<sup>1</sup> There they create a new online map, and using either OpenStreetMap vector data or a tiled map base layer for reference, each imagery can be orthorectified and ultimately composited into a map. The results can be embedded in another website for online viewing, exported as a Tiled Map Service (TMS) service, or printed from a Geographic TIFF (GeoTIFF), depending on the intended use.

The Grassroots Mapping Kit and associated techniques are thoroughly documented at the project wiki, at <http://wiki.grassrootsmapping.org>, and additional support and discussion is available at the project mailing list and blog, which can be found at <http://grassrootsmapping.org> along with extensive documentation of past and in-progress mapping efforts around the world. Printed documentation is also available in the form of available in the form of a 5-page illustrated guide

---

<sup>1</sup><http://cartagen.org/maps/>



and several checklists designed to accompany each kit.<sup>2</sup>

---

<sup>2</sup>See 10.3, and view the guides in Appendix B

## Chapter 2

# Movements towards a participatory and activist cartography

A brief description of three distinct groups of practitioners is worthwhile, as each embodies a distinct conception of mapmaking and its purposes. These three cartographic movements have positioned themselves as challengers to previous forms of cartography, and as such, the following will help to situate the Grassroots Mapping project (in addition to the Cartagen framework) as a similar attempt to broaden participation and reconceptualize the practice.

### 2.1 Experimental geography and radical cartography

A growing movement toward a cartographically literate art practice has emerged which seeks to use cartographic tools and attitudes in a critical and activist manner. Some groups, such as Proboscis, take explicit inspiration from Guy Debord's psychogeographic movement of the 1950s. Others such as the Center for Urban Pedagogy, use mapmaking as a means to explore social and environmental injustice in a participatory manner, often with youth. What these practitioners have in common is that they have begun to appropriate tools and techniques from the GIS industry, applying them towards new socially and politically relevant goals.

Artists like Bill Rankin use the thin-lined mechanical aesthetics of GIS to comment upon the normally cartographically invisible American Indian reservations, emphasizing the incompatibility between conventional, formalized modes of representation and the more complex geographies which exist in the real world. His map, 'The United States?' offers two separate attempts, but Rankin points out some of the difficulties in such an adaptation:

At stake here is the European definition of nation-state sovereignty, which implies a close (and, ideally, consensual) relation between an area on a map and the governance of its inhabitants. It is not simply that a European-style map has a hard time representing the sovereignty rights (or claims) of indigenous peoples; rather, such relations are a priori impossible to depict on a typical map. [69]

The collective Hackitectura inverts a map of the Gibraltar area with Morocco and Western Sahara

on top and Spain and Portugal below, while highlighting the complex landscape of legal and illegal immigration. Graphs, diagrams of security systems, and satellites dot the map depicting ‘the multitude versus the Empire’, along with marks for immigrant detention and the Spanish tomato farms whose need for cheap labor feeds much of the migration. The mapmakers’ willingness to abandon the guise of objectivity in favor of such a clear geopolitical agenda is typical of many members of this wider cartographic movement.



**Figure 2.1:** A selection of articles published by the BBC, linked to the BBC headquarters in my project NEWSFLOW, 2009

Proboscis in particular has produced a number of cartographic works with urban communities with the goal of creating an ‘anthropology of ourselves’ and ‘become co-creators and not just consumers of information’ — the latter of which parallels the neogeographers’ interest in making participants of their audience (See Section 2.3). Their projects take the form of mapmaking workshops and activities, using basic materials like paper and watercolor, as well as high-tech tools such as GPS-enabled mobile phones. They focus on recording the historical narratives of participants while relating the stories to geographic positions and routes in a kind of city-wide game.

Proboscis uses the term ‘bodystorming’ to describe their emphasis on experiencing the world on both a physical and conceptual level, facilitating ‘the transformation of abstract ideas and concepts into physical experiences, a tactile approach allowing us to investigate different qualities that ideas may have when applied to physical settings — part of a dynamic and continuous process of trial and error.’ [65]

By contrast, my own project ARMSFLOW (<http://armsflow.org>, 2007) describes in a purely on-line map the sale of conventional arms between governments worldwide from 1950-2006, using data culled from Stockholm International Peace Research Institute (SIPRI). Red lines of varying thickness (representing an abstract metric called TIV, or trend-indicator value) link buyers to

sellers, and users may explore the data by country or by year. A followup project, NEWSFLOW (<http://newsflow.cartagen.org>, 2009), displays in a similar format connections between news organizations and the locations of stories they publish, as scraped from Google News. In these works, my interest in cartographic activism and data transparency focused mainly on the interpretation and exploration of data, rather than its production or origins. Though visually compelling and information-rich, these two maps are emblematic of the shortcomings of the ‘data visualization’ movement. Natalie Jeremijenko addresses the crux of the matter when she questions the sources of such works:

...the designers of these types of projects use extant data sets from the EPA, from the Toxic Relief Inventory, federal databases, and do so without criticism, without asking how the data is generated, who collected it and under what conditions. That is, what does the data actually represent? [36]

This criticism was revelatory to me, and led to my increased interest in engaging participants not only in interpreting information, but in *creating* information. By augmenting the literacy and ability of individuals to capture, author, and frame new data, we engage a broader public in the role of researcher and of investigator. Rather than playing solely the interpretive role of the designer or editor, I have attempted to insert participants further upstream — closer to the source — with the intent of gaining greater leverage in the construction of geography.

## 2.2 GIS practitioners

Professional map makers have used GIS since the 1960s, which in recent decades has increasingly centered on the ArcGIS suite by ESRI. More recently, GIS methodologies have met with some criticism amongst newer generations of digital map-makers for its widespread use of expensive proprietary tools such as ArcGIS, both for their cost and because, due to their complex interfaces, these tools present a high barrier to non-expert participation. However, it is easy to forget that GIS was originally conceived of as a movement towards a more participatory and interactive cartography, by reducing the costs and increasing the abilities of users to manipulate and publish geographic data.

Another movement known as *critical GIS* but encompassing several groups such as Qualitative GIS, Feminist GIS, Participatory GIS and Public Participation GIS evolved starting in the 1990s with roots in human geography as well as amongst GIS practitioners themselves. Proponents of critical GIS have challenged traditional GIS practice from a humanist perspective for its failure to incorporate non-quantitative sources, and for its ‘potential for exclusion and disempowerment’ [26]. Other proponents of a Qualitative GIS such as Marianna Pavlovskaya have challenged the quantitative basis for GIS, arguing that it often relies on spatial imagination and intuition, as in many techniques based on visual examination. She notes that most GIS software ships with only basic spatial analysis capabilities, and suggests that the high reliance on human reasoning in typical usage has been obscured by poorly-designed user interfaces. Most importantly, Pavlovskaya draws attention to the fact that the most common output of GIS use is data visualization, designed for ‘visual impact’, which preference heuristic interpretation over quantitative analysis. [61]

Proponents of critical GIS argue that GIS should be seen primarily as a power relation, due to its association with ‘authoritative’ quantitative analysis and the ‘fascination of Western science

and geography with vision, seeing, and looking as a primary and supposedly objective way of knowing, which is in fact partial, embodied, and masculinist.’ [61]<sup>1</sup> The resulting image of ‘GIS as a powerful juncture of science, technology, and authority’ [61] leads to an exclusivity that places the benefits of geospatial information and technology beyond the reach of the public and in the hands of those already in power. Pavlovskaya and her colleagues advocate a broader and more inclusive practice of cartography which incorporates a more anthropological and ‘mixed methods’ approach — one which is championed by the Participatory GIS, sometimes known as PPGIS or Public Participation GIS (PGIS) community, which has employed community-produced paper maps and ‘3D model mapping’ where participants construct multimedia scale models of their communities in a discursive and process-focused activity.

Other techniques include ground mapping, performed in an outdoor area using stones or flags to create scaled maps, and relief model mapping using three dimensional cardboard contour maps annotated with pins and labels.<sup>2</sup> As Robert Chambers remarks, PGIS techniques have met with widespread adoption and success across the world, due to their ‘power and versatility... the relative ease with which it can be facilitated, the fun, fulfilment and pride which people derive from it, and its multiple uses by so many stakeholders’. [15]

### 2.2.1 Cartographic ethics

In light of the reassessment of the political and social roles of maps and their production, some from the PGIS community have called for a code of ethics in participatory mapping projects. This seems especially prudent given that the production of maps can have dramatic effects on the residents of the mapped area. Giacomo Rambaldi, Robert Chambers, Mike McCall, and Jefferson Fox proposed in 2006 a set of 33 guidelines entitled ‘Practical ethics for PGIS practitioners, facilitators, technology intermediaries and researchers’. The following is a sampling:

- Do your best to recognise that you are working with socially differentiated communities and that your presence will not be politically neutral
- Consider using spatial information technologies that can be mastered by local people (or local technology intermediaries) after being provided sufficient training
- Be considerate in taking peoples’ time
- Stimulate spatial learning and information generation rather than mere data extraction for outsiders analysis and interpretation
- Ensure that the outputs of the mapping process are understood by all those concerned

[66]

These guidelines demonstrate a belief that maps should be produced *in collaboration with* local communities, and with respect for their needs and interests. Even in the context of an openly activist agenda, they have proved invaluable to me in formalizing and understanding interactions with mapping participants. In particular, they address the core concern of who owns the maps

---

<sup>1</sup>See Section 3.5.

<sup>2</sup>A discussion of the challenges the PGIS movement has faced can be found in Section 5.1.

and for whom they are made; there is often the implicit assumption by enthusiasts of open geodata that simply dumping map data into OpenStreetMap is the end goal. It is important to be aware that most people (and especially those in communities in geographic conflict) are unaware of the existence of OpenStreetMap, and would likely be unreceptive to its benefits.

Robert Chambers in particular warns PGIS practitioners against raising expectations of concrete results, noting that ‘Any process of analysis facilitated by an outsider is liable to raise expectations of some benefit, even when the outsider goes to pains to explain that they have nothing to offer and nothing will follow from their visit. Disappointment, and reinforced disillusion with visitors and organisations outside the community then follow.’ [15]

While this is a highly pragmatic concern, it is concerning and frustrating that many participatory mapping efforts do **not** effect change, or yield benefits for communities in need. It is my belief that by engaging in mapmaking practice which generates truly new information — information which may act as a means of expression and communication with the outside world — there is a strong potential for local communities to gain leverage and derive benefits, including greater inclusion in municipal planning, environmental policy, and legal status. Rather than patronize such participants with a form of mapping which is essentially symbolic and introspective, we must challenge ourselves to invent new rhetorical and tactical mapping tools which can address the needs of the disadvantaged.

Despite sharing many of the same goals of inclusive, participatory techniques, an emphasis on making the audience into producers of information, and inexpensive tools designed for non-experts, neither the critical GIS movement nor the experimental geography movement widely collaborated with or even communicated with the next group, which from a technological perspective has perhaps the greatest potential to innovate new tools and techniques.

## 2.3 Neogeography

With the rise of web-based data and display systems came a group composed primarily of entrepreneurs, programmers and web designers, who have adopted the name *neogeographers*. This group positions itself in contrast to traditional approaches such as GIS, and favors open data sharing, standards-based data formats. Neogeographers advocate a kind of ‘people’s GIS’, and have worked to develop free and open source software tools to replace proprietary solutions. The neogeographic movement, though it may have found its roots in the opening of the Google Maps Application Programmer’s Interface (API) (see Section 5.2), focuses today on largely web-based open source software such as OpenLayers, Mapnik, and GeoDjango. Some desktop map viewing and editing packages such as QGIS or Java OpenStreetMap Editor (JOSM) are also available, though even these are often used to produce data for online publication. The availability of a relatively complete open-source toolchain for authoring and publishing maps is a result of the gradual shift away from easy-to-use commercial APIs. [68] However, some services such as Google’s geocoding API, Yahoo’s Placemaker API, and a variety of commercial satellite imagery sources, are still relied upon — generally because they outperform open-source alternatives. In some cases, equivalent open alternatives are nonexistent or not widely known.

One identifying theme in the neogeography movement is the shift of users from consumers to producers of maps, though primarily in the online world. [55] The ability to create and publish



map data using simple and free tools has dramatically broadened participation in map making, and Rana and Joliveau suggest that neogeography rejects the ‘prescribed role/interaction between the four main components, namely the audience, the information, the presenter and the subject...’. [68] Neogeographers prefer ‘crowdsourced’ data, contributed by collaboration and volunteerism, to proprietary data, which they have come to distrust due to copyright, access, and format and quality limitations. Data produced by the public and liberally licensed for public use may be translated, republished, remixed, and repurposed without parasitic dependence upon large and often uninterested organizations and governments.

Another important aspect of the movement is that the creators of neogeographic software tools typically do not have a formal or academic background in geography or GIS, but come from a programming and software engineering background. This has some technical benefits, in that the solutions they promote and develop are often conceived of from a novel perspective, sometimes resulting in higher performance, broader applications, and reconceptualizations of both for what and for whom maps are made. It has also resulted in an ‘outsider’ attitude amongst neogeographers, and even some resentment from traditional GIS practitioners; this has played an important role in how the movement presents itself to the rest of the world, and what choices it makes in the development of tools. For example, the OpenStreetMap project, discussed at length in Section 5.2.2, was developed in response to the restrictive crown copyright of the British Ordnance Survey national map. [17], and was eventually instrumental in Ordnance Survey’s decision to provide a free dataset. [8]

While neogeography shares many of the goals of the PGIS movement, relatively little communication exists between these two factions due to their different origins and mutually isolated venues for publication.<sup>3</sup> Rana et al describe neogeography as an ‘outcome of the increasingly close integration of our lives with geocomputational and World Wide Web technology.’ That statement may be more accurate if ‘our lives’ refers to the lives of neogeographers, or at most refers to that thin slice of the global population which knows what an API is, or owns an iPhone. As discussed in Chapter 4, most of the world has little or no access to digital geospatial services and information, and this may account for the mounting interest in such tools’ application in areas of crisis or humanitarian need. In the last few years, we see an increasing number of neogeographers engaging in socially or politically engaged work — groups such as the Humanitarian OpenStreetMap Team, DevelopmentSeed, NiJeL, Ushahidi, and many more. Many of these have formed partnerships with larger and more traditional organizations such as the World Bank and the United Nations. A more in-depth examination of such works and the relevant technologies was published in 2008 by Sean O’Connor and the Tactical Technology Collective under the name ‘Maps for Advocacy’. [55] Neogeography and the open technologies it has brought set the stage for an even more inclusive cartography which stands to benefit those beyond the reach of iPhones, GPS devices, and APIs.

---

<sup>3</sup>An exception is Mikel Maron’s efforts in Kibera, among other places, which makes explicit reference to PGIS practices.

## Chapter 3

# Subjectivity in Mapping

The need for a more participatory cartography is predicated on the exclusion of many from the practice of mapmaking as it stands today. Even more importantly, it depends on the point of view that mapping is an inherently non-neutral practice, and that for maps to serve wider and more democratic interests, it must accommodate diverse viewpoints. Maps serve interests, and understanding their role not as documentation of what makes up the world, but as rhetorical, tactical, and *subjective* tools is an important prerequisite to what this document argues.

### 3.1 The mythical ‘complete map’

One common sentiment often heard in contemporary map literature is that the earth is more or less completely mapped. The availability of satellite imagery in tools like Google Earth, and the ability to zoom shockingly far into a dizzying array of places, from power plants in North Korea to the top of Macchu Pichu, gives the casual user the impression that we have indeed created a complete map of the world. However, if one attempts to find imagery of places with lower global economic relevance, it becomes clear that while there may not be many *blank* spots on the map, there are an abundance of *blurry* spots.

This of course sidesteps the fact that an aerial image does not a map make — that is to say, in order to take advantage of the many applications of geographic data, vector maps which geometrically and semantically describe features must exist, including labels, tags, metadata, and even relations, which may be parsed into driving routes. These are almost entirely absent from many areas of the world (see Chapter 4). Amongst cartographers, the idea that maps accurately,

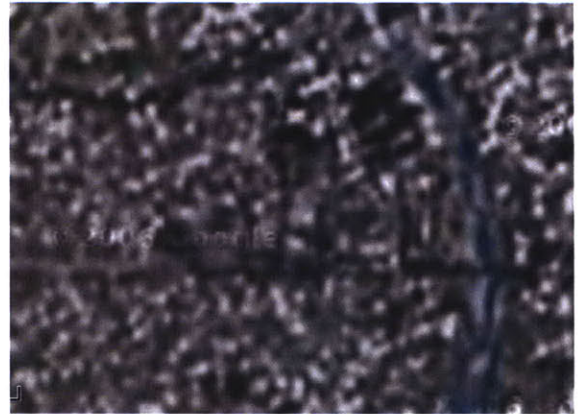

**Figure 3.1:** Kutaisi, the second largest city in Georgia. Google Maps, July 2010



or even completely depict a location is not entertained in a literal sense, yet there persists a sense that complete maps are possible. Within certain realms, communities such as OpenStreetMap have declared completion, as in an email by Etienne Cherdlu to the project's developer mailing list in 2006, entitled 'UK Motorways 100% Complete':

I'm pleased to announce that the main carriageways of all mainland UK motorways have been completed. Over 3,000 km of roadway.

Still, OpenStreetMap's tagline describes the project as an 'editable map of the whole world', and the scope of the project is growing. The inclusion of increasingly subjective data has transformed the project, from road conditions ('surface=unacceptable') to contested political boundaries such as the borders of Palestine or the existence of Western Sahara as a sovereign nation, to the possibilities of including indoor features such as rooms and hallways. Yet the premise of mapping the entire planet should remain an obvious fantasy; in fact, the fiction of such a complete map has been explored by several authors, most notably in a short story by Jorge Luis Borges and Adolfo Bioy Casares, entitled 'On Exactitude in Science':

...In that Empire, the craft of Cartography attained such Perfection that the Map of a Single province covered the space of an entire City, and the Map of the Empire itself an entire Province. In the course of Time, these Extensive maps were found somehow wanting, and so the College of Cartographers evolved a Map of the Empire that was of the same Scale as the Empire and that coincided with it point for point. Less attentive to the Study of Cartography, succeeding Generations came to judge a map of such Magnitude cumbersome, and, not without Irreverence, they abandoned it to the Rigours of sun and Rain. In the western Deserts, tattered Fragments of the Map are still to be found, Sheltering an occasional Beast or beggar; in the whole Nation, no other relic is left of the Discipline of Geography. [11]<sup>1</sup>

Beyond the technical impossibility of *total mapping* lies the trend towards increasingly individualistic, subjective, and divergent models of the world, which inevitably occur as maps become more ubiquitous and more detailed. Rather than pursuing the goal of a single canonical representation of the planet and attempting to encompass conflicting interpretations, participatory mapmaking should embrace diversity, and allow for separate but related means of describing the world.<sup>2</sup>

<sup>1</sup>The idea of a 1:1 map of a whole country was originally mentioned in Lewis Carroll's novel **Sylvie and Bruno Concluded**.

<sup>2</sup>My belief in the value of a divergent paradigm for digital mapmaking was also the impetus for my development

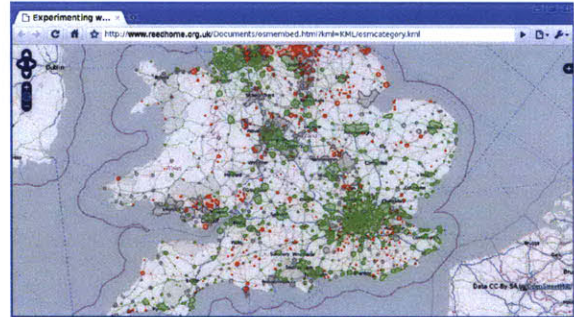

**Figure 3.2:** A map depicting all 'incomplete' areas of OpenStreetMap in the UK. (<http://www.reedhome.org.uk/Documents/osmembed.html?kml=KML/osmcategory.kml>)

## 3.2 A ‘ground truth’ policy for collaborative mapmaking

OpenStreetMap has in fact begun to encounter a number of challenges due to the inherently subjective nature of mapmaking — especially as the project has grown to encompass dozens of countries, cultures, and socio-political perspectives. Due to the project’s open and wiki-like architecture, occasional disagreements occur between users, and a convention has been established to resolve such disputes. OpenStreetMap can accommodate an unlimited number of language translations for the label of a map feature, but the **default** label is what is displayed on the web map at OpenStreetMap.org. The ‘on the ground’ policy, as it is known, places any editorial decision in the hands of ‘the people on the ground at that location’. The policy, whose definition was led by Mikel Maron, was originally proposed in response to an ‘edit war’ in 2007 between Turkish-speaking mappers from northern Cyprus and Greek-speaking mappers from southern Cyprus. [58] While such a policy has in general served the project well, its necessity is an indication that as mapmaking becomes a more widespread and inclusive practice, the increasing diversity of viewpoints will make a single canonical map less feasible.

## 3.3 Privacy and mapping, privacy and open geodata

Privacy is of course yet another reason to shy away from total mapping. Indeed, for any publicly available map to include such details as the positioning of my coffee table or wifi router <sup>3</sup> offers a more clear view into my personal space than I care to allow. The further Google Street View and similar services invade that space, the more the public will feel uncomfortable with such overreaching cartographic enthusiasm. Appropriating these technologies in support of bottom-up efforts can invert these issues, and the ability to make maps *for oneself* as analytic tools, or to publish selective geographic information to a specific audience for tactical or advocacy reasons, can recast such technologies as empowering and enriching.

One of the most difficult aspects of participatory mapmaking, is that I am often asked questions such as, ‘Why would a community allow you to come take aerial pictures of their homes?’ This is a fair question, but one which thoroughly misconstrues what I am advocating. My work is intended to teach and assist communities and individuals to map themselves, for themselves. This includes building literacy and proficiency in geographic tools and information, and making good choices about how to publish their maps — if at all. The maps which I have published here are only those for which I have requested specific permission to reproduce for purposes of education and research. The decision of a community to publish their work is one which I am very cautious to encourage, as another question I am asked is, ‘Isn’t mapping just a means for the state to exert influence and control over geography?’ If communities and individuals are not in control of their own geodata, the answer may be ‘yes’!

---

of the Cartagen web mapping framework, which shifts the interpretation and rendering of map feature data to the client side (rather than generating a single canonical server-side rendering), allowing for endless variety of representation.

<sup>3</sup>A discussion of Google’s collection of personal WiFi data can be found here:  
<http://bits.blogs.nytimes.com/2010/05/14/google-admits-to-snooping-on-personal-data/>



### 3.4 Mapping: a tool of empowerment or control?

The idea that mapmaking is a kind of cartographic harvesting of the most vulnerable places and people on the planet is a justifiable fear, however it is based on a relatively one-sided reading of history, and especially of contemporary mapping practice. Maps can just as effectively be used to defend as to conquer, as a wide variety of cartographic activists have demonstrated. B'Tselem, a progressive Israeli human rights group based in Jerusalem, has used maps of Israeli settlements in the West Bank to support their critique of those settlements as the illegal annexation of traditionally Palestinian land. Jai Sen, a political organizer in Calcutta in the 1980's, used maps of urban slums as a form of testimony, effectively proving that people lived on the land before authorities bulldozed it and claimed that it was uninhabited from the start.

VirtualGaza, a project by Josh Levinger, published narratives by victims of the 2008 war in Gaza, linking the cartographic representation (one reason for the conflict) with the human stories and images of the destruction it caused. The OpenLayers-based map, available at <http://virtualgaza.media.mit.edu>, protected participants' locations by purposely categorizing them by region instead of displaying more precise coordinates. Levinger's second project in the area, GroundTruth, demonstrated a routing algorithm which could, given a user's legal status, create a travel plan which would avoid IDF checkpoints, actively seeking to disrupt the balance of power in the region with the tactical use of cartographic information.<sup>4</sup> Other cartographers have during the same conflict in Gaza, Mikel Maron defended his work towards the participatory creation of a free and open map of Gaza:

...it's frankly the same security through obscurity argument peddled for centuries... a strategy on the verge of finally dissolving in a world of openness and transparency. The IDF have access to much better intelligence and imagery than we'd ever have, they fly drones over Gaza, there's a 2m resolution commercial limit in all satellite imagery over Israel — guess who gets to see the sub-meter imagery? Gazans have nothing to gain by trying keep secrets, the asymmetry of that game is overwhelmingly not in their favor. [43]

Maron later refined his position to except certain highly vulnerable groups<sup>5</sup>:

<sup>4</sup>The routing system was disabled when it became clear that up-to-date checkpoint information was unavailable, and that users might be presented with obsolete data.

<sup>5</sup>See Section 2.2.1 for a discussion of PGIS ethics

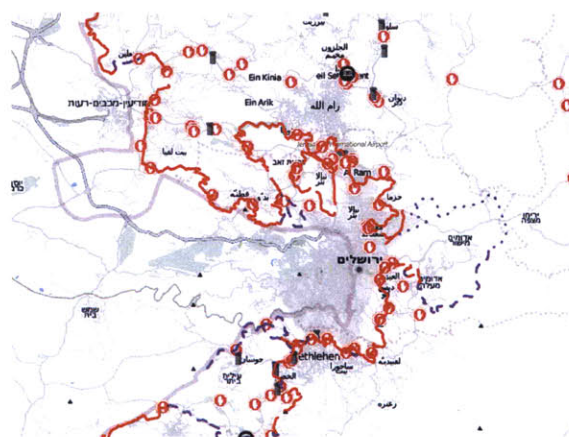

**Figure 3.3:** The Green Line, Israeli settlements, and checkpoints near Jerusalem and Ramallah, on Josh Levinger's GroundTruth interactive map. (<http://groundtruth.media.mit.edu>)

In general, I view these edge cases as a question of power. Hiding information protects those already in power, but not those that are already marginalized. Legitimate cases [for obscuring data include] only information that puts dis-empowered people at risk, such as refugee routes along the Burmese-Indian border. [44]

However the gist of his argument is sound — that cartography is necessarily a losing game only for those who are unable to participate in its creation. Those who are unable to communicate in the relevant cartographic language of power – be it GeoJSON, TMS or just paper – never even know they are being mapped, or what that might mean for their well being or safety.<sup>6</sup> In some ways, this is a subset of the debate championed by Evgeny Morozov, Clay Shirky, and Patrick Meier<sup>7</sup> over whether new media is a force for democracy, or at least whether it supports ‘popular resistance against repressive rule’ as Meier puts it. [50] Morozov even specifically mentions mapping, for example when he ridicules the sappiest anecdotes of the technological ‘freedom fighters’:

...Burmese monks defying an evil junta with digital cameras; Filipino teenagers using SMS to create a textual revolution; Egyptian activists using encryption to hide from the all-seeing-eye of the Mukhabarat; even Brazilian ecologists using Google maps to show deforestation in the Amazon delta. [52]

In Morozov’s opinion, the belief that such technologies can disrupt power relations ‘...requires certainty that only pro-western and pro-democracy forces will participate.’ His examples, though anecdotal, are sobering: ‘In Russia, the internet has given a boost to extreme right-wing groups like the Movement Against Illegal Immigration, which has been using Google Maps to visualise the location of ethnic minorities in Russian cities and encouraging its members to hound them out.’

(rev. see following quote)

The problem with this debate is that it is too abstract. We cannot say universally that mapmaking (or any other technology) will support local needs over those in power, but by working closely with local participants in a sensitive manner, we can invert the flow of information and affect power relations on a local scale. Balloon and kite mapping is not a scalable technology — it would be impractical for Google or governments to use these techniques to map entire countries. However it is ideal for small-scale use, and has important advantages in cost, repeatability, resolution, and speed in that context. My attempts to apply these tools and techniques have focused on these benefits, and in the specific settings in which I have worked, they have allowed local groups to produce better maps than anyone else, albeit for a limited but *highly relevant* area. In a time when many in the crisis community were struggling to get large organizations such as Google, the United Nations, etc. to release satellite imagery<sup>8</sup>, the Louisiana Bucket Brigade actually licensed map data to Google — data gathered using Grassroots Mapping tools and techniques.<sup>9</sup>

Ultimately, the ability of mapmaking tools to empower local interests has more to do with the degree of adoption and appropriation of those tools by participants than it does with any overarching

---

<sup>6</sup>A common criticism by PGIS practitioners of so-called ‘remote sensing’. See Section 5.1

<sup>7</sup>See <http://www.prospectmagazine.co.uk/2009/11/how-dictators-watch-us-on-the-web/> for the Morozov/Shirky debate, and <http://irevolution.wordpress.com/2010/01/07/morozov-vs-shirky/> for Patrick Meier’s analysis.

<sup>8</sup>See Section 4.4.1

<sup>9</sup>See Chapter 8



technical aspect of the project. For this reason, I have focused on improving collaboration and building trust with the communities I work with, in addition to an aggressive program of workshops, demonstrations, and user-friendly guides to build a strong pedagogical platform. This approach builds upon the rejection of technological determinism in political processes advocated by Philip Agre, who argues:

Research on the Internet's role in politics has struggled to transcend technological determinism — the assumption, often inadvertent, that the technology simply imprints its own logic on social relationships. An alternative approach traces the ways, often numerous, in which an institution's participants appropriate the technology in the service of goals, strategies, and relationships that the institution has already organized. [3]

### 3.5 Maps as truth

Maps carry a sense of authority that few other forms of evidence share. This is in part due to an understanding of satellite or aerial maps as a kind of 'window into the world', depicting the planet 'the way it really looks'. In photography, by contrast, the editorial and subjective role of the author is accepted, despite the damage which 'photoshopping' has inflicted on the perceived truth or objectivity of the photographic image. Maps, however, continue to be understood as direct representations of reality, despite the inherent subjectivity of image selection, color, brightness, and contrast processing, not to mention the editorial eye necessary in reading and interpreting such imagery.

The best example of this attitude is of course the use of satellite imagery by Colin Powell at the UN Security Council in February 2003, which he presented as evidence to support the existence of weapons of mass destruction in Iraq, and to justify the invasion of the country. While the subsequent complete absence of weapons did little to diminish the public's faith in such imagery as objective evidence, Powell mentions in his testimony how difficult it is to interpret satellite imagery:

Let me say a word about satellite images before I show a couple. The photos that I am about to show you are sometimes hard for the average person to interpret, hard for me. The painstaking work of photo analysis takes experts with years and years of experience, poring for hours and hours over light tables. But as I show you these images, I will try to capture and explain what they mean, what they indicate to our imagery specialists. [33]



Figure 3.4: 'Image 16: Chemical weapons leaving Al-Musayyib' [7]

Later, after showing a purported chemical weapons site, he explains:

How do I know that? How can I say that? Let me give you a closer look. Look at the image on the left. On the left is a close-up of one of the four chemical bunkers. The two arrows indicate the presence of sure signs that the bunkers are storing chemical munitions. The arrow at the top that says security points to a facility that is the signature item for this kind of bunker. Inside that facility are special guards and special equipment to monitor any leakage that might come out of the bunker.

The truck you also see is a signature item. It's a decontamination vehicle in case something goes wrong. [33]

Despite the 'years and years of experience' he claimed, an earlier analysis of the imagery to which Powell had access classified the claims as 'weak' and points out that the so-called contamination vehicles are in fact simply water trucks. Though they acknowledge that these **could** have been used for chemical weapon decontamination, the doubt they express stands in contrast to the assertion of 'facts' that Powell presented to the UN:

— 10-11.\*\*\*/WEAK. We support much of this discussion, but we note that decontamination vehicles—cited several times in the text—are water trucks that can have legitimate uses. A safer characterization is, 'a vehicle used for chemical weapon decontamination.'

— 11.\*\*\*/WEAK. We agree there has been suspicious activity [redacted], including presence of a decontamination vehicle. We caution, however, that Iraq has given UNMOVIC what may be a plausible account for this activity—that this was an exercise involving the movement of conventional explosives; presence of a fire safety truck (water truck, which could also be used as a decontamination vehicle) is common in such an event.' October, 2002, classified National Intelligence Estimate (NIE) 'Iraq's Continuing Programs for Weapons of Mass Destruction' [71]

What is most alarming about this kind of rhetorical use of map imagery is that it represents a means for those in a position of power to assert or manipulate truths about places they have never been, without the involvement of human testimony from those who have. The public perception of maps as an objective, quantitative standard of evidence is likely due to the difficulty and expense of producing map imagery, and the traditional monopoly of the government and high-tech industry in the production of such imagery. Still, as we see in Powell's testimony, even the highest levels of government are complicit in the construction of maps as a supposedly authoritative and objective form of information.



Figure 3.5: 'Image 13: Sanitization of Ammunition Dump at Taji' [7]



## 3.6 Maps: rhetorical, even tactical

This use of mapping as a form of political persuasion is nothing new, from a historical perspective, but the increased obfuscation of such information in technical terminology and the use of precise measures — referring to maps by their ‘centimeter accuracy’, for example — has made maps more difficult for lay persons to critique. As Dennis Wood points out in his classic ‘The Power of Maps’, such metrics give the ‘false impression of “scientific accuracy” and completeness’, serving to purposely exclude the public from cartographic discourse. [86]

### 3.6.1 Activist cartography

A new generation of mappers, including many from the experimental geography movement and increasingly amongst neogeographers, has turned this authoritative dimension of mapping on its head by employing many of the same techniques to advance alternative agendas. The increasing democratization of mapmaking technology, and the rapid advances of open-source and inclusive techniques have enabled individuals to leapfrog traditional mapmaking regimes.

It is precisely the rhetorical qualities of mapping which the Institute for Applied Autonomy explores in ‘Tactical cartographies’ — but as that name suggests, the Institute goes beyond rhetoric to incite action. Defining tactical cartography as ‘the creation, distribution, and use of spatial data to intervene in systems of control affecting spatial meaning and practice’, they are not only fighting a war of words (or pictures) in highlighting issues of concern. Their maps act as tools in the direct intervention in problematic situations, transitioning from the (still important) discursive products of maps-as-information to their use as informational weapons in a direct engagement in ‘politics and power’. [28] In this vein, the Institute authored a pocket map in 2002 depicting all surveillance cameras in Manhattan, so that users might not only learn about the increasing prevalence of a surveillance society, but actively avoid zones under surveillance in their daily life. This movement beyond a symbolic role for mapping — to legal, activist, and primarily action-based outcomes, is what I have attempted to achieve in the Grassroots Mapping project.

## Chapter 4

# The Need for Geospatial Data

### 4.1 Two worlds of mapping

Present-day users of web-based mapping products such as Google Maps are presented with an extremely rich cartographic landscape when they view maps of first-world urban centers such as New York and San Francisco. Real-time traffic data may be overlaid in lines of shifting red and green, and many buildings appear in orthographic '3D'. Well-known restaurants are interspersed with subway stops whose schedules may be called up with a few clicks. Routing algorithms offer turn-by-turn directions, optimized for pedestrians, bicyclists, and motorists.



**Figure 4.1:** Views of Manhattan, left, and a settlement in Lima, Peru, right, as seen in Google Maps <http://maps.google.com>

Many are surprised when they use Google Maps to 'visit' places such as Lima, Peru, a metropolis of 11 million people, only to find that not far from the city center are vast areas of indistinct and unlabelled buildings. While some of these are recognized and official parts of the Municipality of Lima, many are informal settlements, whose inhabitants lack title to their lots of land, and whose streets and buildings do not appear on any city map. Many of these settlements, or 'invasions' as



they are known to Peruvians, are governed by leaders who are either elected by the several hundred inhabitants, or who maintain control through intimidation — employing thugs to collect taxes and enforce rules.

This state of extralegal urban sprawl exists in many parts of the world; according to UN-HABITAT, more than a sixth of the world's population lives in urban slums, and that number is likely to double by 2030. [77] A legal process may exist to establish official land ownership in these settlements, and to issue deeds to their inhabitants (as it does in Peru), but in many cases the state lacks the resources to quantify or map these areas. UN-HABITAT data indicate that 'many local governments do not have mechanisms to monitor urban growth in a systematic manner, even less to monitor informal urban growth' and that '80 cities out of 120 recognize that they do not possess monitoring systems to track changes in the spatial dimension of the city' [78]

While accessible and participatory mapmaking is by no means a solution to this problem, many of the negotiations occurring in such areas are taking place in the language of cartography — whether intentional or not, cartographic invisibility is often the first step to settlements' exclusion from planning processes:

...slums — all variety of precarious settlements — represent the 'invisible' city, often omitted from official maps and documents and frequently physically hidden by local authorities by colorful walls and fences. — UN-HABITAT [76]

## 4.2 Mapping for social change

Activists have used maps to defend vulnerable areas for decades; Jai Sen's work defending Calcutta slums, discussed in Section 3.4, is a good example. More recent efforts by Rio de Janeiro-based Rede Jovem seek to promote the culture of the city's favelas using maps, in part to protect them from the imminent relocation due to the upcoming 2016 Olympics. At the Maps for Making Change project by Bangalore-based Center for Internet and Society and Tactical Technology Collective, participants advocate mapping the 'greyed-out zones' and using 'geographical mapping techniques to support struggles for social justice in India'. [72]

PGIS researchers have also established a strong case for the diverse needs which participatory mapping can address. Robert Chambers lists several, ranging from benefits to outside aid organizations to direct benefits to the local community:

- 'Social mapping, identifying people 5, livestock, children who do and do not go to school, people in different livelihood and other social categories, wealth and wellbeing groups...
- 'Health mapping, for people with health problems, disabilities, special knowledge etc in communities. In the UK participatory mapping by women has shown the location and concentrations of breast cancer (Lynn et al n.d.)
- 'Farm mapping, combined with mapping of nutrient flows within the farm and over the farm boundaries (as undertaken by many organic farmers in Karatina, Nyeri District, Kenya in 1996)'

[15]

## 4.3 Environmental assessment

As Chambers notes, beyond issues of land rights and ownership, there are many other potential uses for inexpensive map data; the ability to produce photographic, or raster maps of sensitive environmental sites may empower small organizations which are unable to acquire timely or high resolution satellite images of sites of interest. Aerial imaging is a form of mapmaking particularly suited to environmental monitoring due to its ability to not only delineate regions of social and political interest, but raster data which can be used to compare plant growth, erosion, and even animal life. One case study we will examine is that of a group of environmental activists known as Coal River Mountain Watch. The West Virginia-based group have sought to gather meaningful and quantitative evidence of the environmental damage and health hazards of mountaintop removal mining across the Appalachia region of the United States. Besides the prohibitive cost of traditional satellite imagery and high level of expertise required by traditional GIS tools, they and other environmental activists strive for data which will make a visceral and emotional impact on policymakers and regulators, as well as the general public.

Currently, activists in Appalachia make widespread use of water conductivity tests to determine the degree of contamination in waterways due to runoff and blackwater releases. Conductivity is a secondary measure, and, though highly standardized, cannot convey the same sense of urgency as photography of, for example, a blackwater release, or the devastation that persists even in supposedly replanted reclamation sites. Aerial imaging, or specifically mapping, is an ideal blend of direct measurement and visual impact, and its main detractor is its price; overflights cost hundreds or thousands of dollars each and image processing is labor- and skills-intensive. A collaborative project examining the applicability of Grassroots Mapping tools to this problem was performed in May 2010 and is discussed in Section 10.1.

### 4.3.1 Asset allocation mapping

A subset of environmental monitoring is asset allocation mapping. Asserting a voice in the management of natural resources is dependent on quantitative information on the extent and valuation of the land, which is often carried out using GIS, a language of power from which local communities are often completely excluded. Peter Poole's article 'Is there Life after Tenure Mapping?' and report 'Information: the First Conservation Asset' examine in detail a number of case studies where participatory mapping was used by indigenous communities to support the 'stewardship of biodiversity' [64]. Citing examples of his and others' work from Venezuela, Suriname, Belize, and elsewhere, Poole shows how cartographic techniques helped not only to monitor the activities of industrial development and extraction industries, but in some cases to take legal action against such initiatives.

Poole distinguishes between asset-based strategies and rights-based strategies, where the former uses GIS tools to assert local control over territory in specific actions against asset extraction industries, rather than the rights-based approach of seeking broad legal recognition of territorial claims at the state level. [63] While some of the examples he cites make use of GPS track collection or sketch mapping, the emphasis on environmental assets often necessitates raster imagery instead of coordinate data, and as such, Poole's project in Belize has made use of light aircraft photography, as well as kite and balloon photography, in collecting and presenting evidence to support claims. [64] The successes of this strategy present an exciting opportunity for such dramatically lower cost

aerial photography techniques as offered by the Grassroots Mapping project, and I am excited by the prospect for future collaboration.

## 4.4 Open geodata and crisis mapping

### 4.4.1 Crisis mapping and Ushahidi

The ability of participatory mapping to provide accurate on-demand maps of changing situations has obvious applications in disaster response and management. A variety of different crowdsourced or grassroots mapping strategies have evolved in recent years with the intent to respond to, document, analyze, and report on the real-time occurrence of disasters and crises. From environmental crises such as the April 2010 BP Oil Spill in the Gulf of Mexico to the humanitarian crisis in the aftermath of the January 2010 Haitian earthquake, a clear need has evolved for low-cost, decentralized situational awareness and documentation tools with geospatial features. Here I discuss some of the challenges of fulfilling such diverse needs under unpredictable conditions.

#### Ushahidi

The Ushahidi platform has emerged as a common and easy-to-install system for crowdsourced crisis reporting. Developed in collaboration with Kenyan programmers to help voters report election violence in Kenya in 2008, it allows citizens with mobile phones to send 140-character text messages to a publicized telephone number. [56] These messages are read by a group of editors, who attempt to identify where the messages were sent from, and are published on a web site as red markers at their best-guess location. That users self-report their locations, and may do so inaccurately, is tolerated because it may represent a means of privacy for some users, though Patrick Meier also suggests that in the aggregate it is quite difficult to ‘fake’ an event. [49] In many cases no verification of reports is possible, yet in emergency response situations this has proven not to impede the use of Ushahidi data by agencies such as (in the Haitian earthquake of January 2010) the Coast Guard, the US Marine Corps, and FEMA. [47][46]

Ushahidi works in many cases because it is superficially simple to understand: visitors to an Ushahidi web site see a series of dots with messages such as ‘I’m stuck under rubble’ and imagine a person sending such a message from their cell phone. It makes use of existing communications infrastructure — namely that most people have cell phones — and relies on both on the ability to send text messages and a willingness to send reports to a site which is not immediately viewable. However, Ushahidi is not a means to ‘make’ a map per se, but rather to collect data on events occurring at specific times, and correlating them with an existing map.

Ushahidi has been successfully used to gather and publish extremely up-to-date information about unfolding crises, for example in the instance created by the New Orleans-based environmental group Louisiana Bucket Brigade (LABB) in response to the BP oil spill in April 2010. The kind of information it provides, however, is difficult to verify or to quantify, and is more useful in the context of emergency response than in evidence-gathering. [48] Locations must often be approximated to the nearest town or city, and most reports are often just a few words with no name or photographic evidence. While geotagged photographs can be uploaded to Ushahidi, EXIF data can be falsified, and in many cases there is an additional need for quantitative data. Map imagery provides more

comprehensive information in that every pixel of a map has a corresponding location in the real world, allowing it to be correlated against other maps.

A combined strategy involving the use of an Ushahidi-like platform with aerial imaging can result in clusters of crowdsourced reports providing target sites for followup mapmaking sessions. This process was employed in the BP oil spill in the Gulf of Mexico between the LABB Ushahidi instance and LABB-led Grassroots Mapping trips.<sup>1</sup> Maps of oil-affected areas were then posted back to the Ushahidi site as TMS layers.

## Satellite imagery

Public access to up-to-date imagery of crisis areas has become somewhat of a hot-button issue in crisis mapping circles, as those companies and agencies in control of the imagery do not always elect to release it, or to license it freely for any use. Whether due to an unwillingness to offer expensive imagery for unrestricted use, or due to the administrative burden of actually publishing such data for download under a permissive license, access to satellite imagery has become a frequent bottleneck for aid organizations.

Specifically in the bottom-up response to the Haitian earthquake and subsequent humanitarian crisis of January 2010, access became more difficult within weeks of the crisis. While GeoEye and other vendors generously offered open access to satellite imagery in the initial weeks of the crisis, most did not elect to do so on an ongoing basis, or for subsequent crises such as the February 2010 earthquake in Chile. This has caused a great deal of frustration for those outside the largest and wealthiest organizations. Specifically, Google and GeoEye's decision to revert to their standard license (severely limiting reuse) for new satellite imagery of Port au Prince after January 2010 elicited questions from the broader crisis response community, as voiced by Mikel Maron on the Crisis Mappers mailing list in late April 2010:

Maybe you can explain why Google has not continued the extremely helpful position it had in January? Is the community of CrisisMappers doomed to lose that culture of sharing? Can't we do better?

In the February 2010 earthquake in Chile, a similar plea for imagery was sent to the same list, prompting a reply from a UN-SPIDER representative. UN-SPIDER or the United Nations Platform for Space-based Information for Disaster Management and Emergency Response, is an organization whose self-described aim is in 'providing universal access to all types of space-based information and services relevant to disaster management' which it fulfills by 'serving as a bridge to connect the disaster management and space communities...' [79]. However, the organization has been slow to adopt truly open data sharing policies, and to date makes relatively few data sets available to the public; most are reserved for so-called *Authorized Users* — typically government agencies and large disaster response organizations. [74]

Ultimately, citizen-led mapping efforts present an opportunity to bypass this bottleneck by providing high-resolution, timely aerial imagery at low cost. Such an effort occurred during and after the 2010 BP oil spill in the Gulf of Mexico and is discussed at length in Chapter 8.

---

<sup>1</sup>See Chapter 8

# Chapter 5

## State of the Art

### 5.1 Participatory GIS for Development

As discussed in Chapter 4, PGIS researchers have used geospatial technology since the 1990's to support communities in developing contexts for purposes such as making tenure claims, environmental defense against petroleum and other extraction industries, as well as for community planning purposes. This focus on underprivileged and excluded communities is a natural extension of the PGIS belief that, as Giacomo Rambaldi put it, 'GIS, spatial data, and maps produce and negotiate politics and power relations', and their potential to 'foster participatory decision making processes.' [67][57] Perhaps most importantly, such efforts promise to look beyond traditional technologies and systems of knowledge. This echoes Sarah Elwood's hope that alternative GIS movements 'could incorporate diverse forms of spatial knowledge and promote multiple epistemologies'. [27]

Examples of adoption of geospatial practices amongst vulnerable communities are widespread, incorporating a variety of techniques including the use of handheld GPS devices to delineate ancestral boundaries, traditional pen-and-paper drawing on terrain maps, and even aerial photos from flyovers in lightweight aircraft. However, critics of PGIS practice point out that despite the emphasis on inclusion in the mapmaking process, final map processing is often outsourced to 'real' GIS experts, subverting the intent to involve participants directly in the production of their own maps, and building dependence on outside entities. While in some cases, local mapmakers have been successfully trained to use traditional digital GIS tools, obscure interfaces and basic internet access and literacy issues often present substantial challenges to this approach. [63]

Also concerning is the persistence of a detached anthropologic attitude, where researchers distance themselves from the data they are 'capturing'. In many PGIS publications there is a definite note of surprise that 'indigenous' communities, whether in sub-Saharan Africa or simply in communities without a high degree of technical fluency, could author good maps or manage geospatial data. The excitement over the moment of cartographic understanding which the following narration by Robert Chambers recounts is tempered by the condescension it implies:

It was also in 1988 in an AKRSP (India) RRA training... that a headman, asked to present to the villagers the map the outsiders had draw, had difficulty until he turned it "upside down", which was the way he and the villagers saw their village . . . . We

were teetering on the brink of learning that “They can do it”. [16]

PGIS researchers have not been insensitive to these issues; Chambers himself points argues that ‘Many ethical issues present troubling dilemmas, and lead to overarching questions about empowerment and ownership. Questions to be asked, again and again, are: Who is empowered and who disempowered? And, who gains and who loses?’ [15]

In practice, there is a question of formats: while for many communities a paper map would be the ideal end product, many cartographers feel the need to produce digital maps in a variety of formats, such as shapefile, Keyhole Markup Language (KML), Web Map Service (WMS), etc. This raises the question of who the intended audience is — the funding agency, perhaps, or the PGIS academic community, or even the blogosphere. These are valid considerations; if the mapmaking is intended to help a community to communicate with official entities, i.e. to influence a cartographic power relation, a digital end product may help to ‘translate’ local knowledge into the relevant language of power.

To be fair, outsourcing of final map processing may seem like the only way to produce a completed map without the challenging prospect of training local participants in the use of GIS software. It may also be a means to build a better and more integrated relationship between the local community and those governmental entities they are attempting to communicate with. However, such benefits are speculative at best, and Peter Poole argues that such an advantage ‘has yet to be widely demonstrated’, citing examples in Suriname and Venezuela. [63]

Such difficulties suggest that a broader reconceptualization of GIS tools and practices — which adapt geospatial interfaces and tools in order to lower barriers to entry — may allow vulnerable communities more direct control over their geodata, its publication and use. The Grassroots Mapping project proposes an alternative geospatial workflow which echews expensive handheld GPS devices and complex software, in favor of direct photographic imaging. Design decisions have promoted intuitive and user-friendly interfaces (see the discussion of ‘rubbersheeting’ in Section 6.2.3) over automated ‘black box’ approaches. While the workflow I propose does depend upon internet access, it does so with the awareness that the ability to produce digital output is an important part of participation in broader geospatial discourse. Many governmental and aid organizations, and of course members of extraction industries, rely upon and communicate with GIS tools and formats, and in order to participate in decisionmaking with such entities, digital mapping is often a prerequisite.

## 5.2 Web mapping

With these challenges in mind, it is especially exciting that recent advances in web-based digital mapping tools have dramatically broadened access to geospatial technologies. Some degree of mapmaking ability has become commonplace to the internet-connected public since the advent of highly user-friendly ‘slippy map’ interfaces such as Google Maps. The release of the Google Maps API in the summer of 2004 was an important milestone to would-be cartographers, allowing users to modify and repurpose Google’s web map services for new purposes. Among early applications of the API was the GMaps Pedometer, which would output the length of a path you walked, along with how many calories you burnt. [29] From the frivolous to the essential, this means of mapmaking has become widespread and relatively easy. However, many would argue that this is



not mapmaking at all; most of the users of Google Maps do not edit the underlying map data, but overlay points, lines, and polygons **on top of** Google’s proprietary data — an obscure but important fact which has direct bearing upon a broader participatory cartography.

### 5.2.1 Google Maps and proprietary data

In fact, not only Google Maps, but the vast majority of the online maps are based on the relatively static base maps made available by larger organizations. Google and other providers of map data publish these maps as collections of small image ‘tiles’; JPG or PNG images of 256 by 256 pixels, which are rendered ahead of time and cached. These are served using Apache or another conventional web server. The main benefit of this technique is that it serves map data as a set of regular image files; a standard and highly optimized means of distribution. These are re-assembled in the browser into an apparently continuous map, and as the user pans or ‘slips’ around, new tiles are transferred to maintain the illusion of continuity.

A second reason for the use of map tiles is that it is quite difficult to reconstruct the original discrete vector data set from map tiles; in this respect they are similar to compiled code. Google and other commercial map vendors do not share their point, line, and polygon data, nor do they make metadata such as labels or land use markers available. Distributing tiles gives them a degree of control over what source data they choose to release.

Distributing the underlying data used to generate these tiles conflicts with these companies’ business models: such data is valuable intellectual property. The tile-based rendering system strips the map of its metadata, making a local, or personal, critical, or revisionist interpretation quite difficult. Tiles are immutable — they contain no information about authorship, no hyperlinks, and in order not to crowd a given tile, each one displays only a selection of available data for that corresponding area of the world. Though originally motivated by technical limitations, the near-universal use of tiled maps has become a form of exclusion, allowing large organizations to control maps in spite of the common rhetoric that the Google Maps API has enabled a more open, participatory cartography.

Open data projects such as OpenStreetMap, the ‘wiki map of the world’, do just the opposite — like the open source software projects they took inspiration from, they publish the entire dataset as coordinates, semantic tags, polygons, and most importantly, time and authorship data. Though most maps using OpenStreetMap data are tile-based, the underlying data is freely available from the project’s website — anyone with enough disk space can download the entire planet’s worth of data (over 200 gigabytes when loaded into a database) and create their own maps. In that dataset in particular, authorship data actually outweighs its geometric counterpart. Perhaps even more tellingly, historical data — for areas of the map which have been overwritten — occupy more

**composition of a typical OpenStreetMap API response**

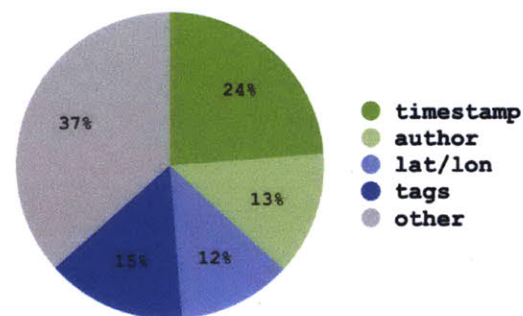

storage space than current data. This suggests that authors have challenged each other's data more than they have added new data to unmapped areas. [81]

## 5.2.2 OpenStreetMap

OpenStreetMap.org, taken as an open-source software project, a database of open geodata, and a community of volunteer mappers, represents one of the best examples in recent years of the *neogeographic* response to PGIS. That is, without explicit ties to the PGIS movement, or reference to the movement's two decades of literature and research, OpenStreetMap (or OSM, as it has become known in neogeographic circles) has attempted to meet many of the same goals since its founding in 2004. OSM encourages volunteers around the world to contribute to a single, shared digital map and corresponding map database. [17]

In many ways it has met with wild success, and the size and detail of the OSM map database is formidable. In July 2010, the project included over 700 million points, making up some 56 million polygons, all contributed by more than 280,000 users. [60] However, participants are overwhelmingly European and American, and tend to be wealthy due to the emphasis on internet connectivity and the use of GPS devices to produce new map data.

In fact, the OSM data collection strategy relies most heavily upon three sources. First, existing municipal and public domain databases make up an enormous part of the available data; the TIGER database produced by the US Census increased the size of OSM by a factor of twenty. [83] Second, tracing of satellite data with the Potlatch, JOSM, and other tools to extract vector data from rasters plays a large role, especially in areas with few local participants. This technique was used in the OSM Gaza project to map all of Gaza using a satellite dataset purchased for \$5,000 from DigitalGlobe using donations during the Gaza war in late 2008. [42][17] While convenient in that it does not require mappers to actually travel to the places they are mapping, it does not actively involve residents of an area in the mapping process, and suffers from many of the shortcomings which inspired the PGIS movement.

Finally, much of the OSM database was created by individuals carrying GPS devices to record GPX tracks, or collections of latitude/longitude coordinates. These are later uploaded, annotated and merged into the main OSM database using tools such as JOSM. This is the preferred means of collecting data because of its high accuracy, its emphasis on firsthand mapping, the clear legal ownership of the data, and because of the implicit belief among many OSM participants that better maps are made 'on the ground'. This belief is supported by the 'on the ground' policy stated explicitly in the OpenStreetMap wiki, as is discussed in Section 3.2.

## 5.2.3 The modern open-source geostack

Another interesting aspect of OpenStreetMap is that it represents a deployed and working combination of many of the premier open-source mapping tools available today. It makes use of OpenLayers, a web browser-based framework for displaying raster map tiles using JavaScript. Tiles are produced using Mapnik, the popular open-source tile renderer. An array of other open-source utilities are used to create, edit, translate, import, and export the data. The Grassroots Mapping project, and especially the Cartagena Knitter, can be seen as an opportunity to augment this geostack with an equally open means of capturing source imagery and integrating such data into the open-source



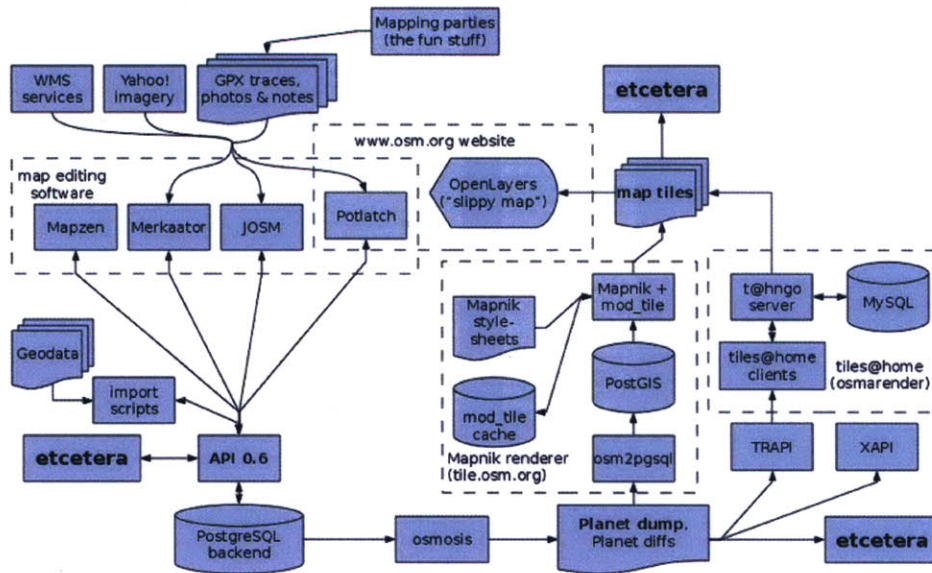

**Figure 5.1:** A system diagram of the OpenStreetMap, courtesy Iván Sánchez Ortega. The red box which I have added to the upper left represents how the Grassroots Mapping project may integrate with this system.

workflow.

## 5.2.4 Humanitarian OSM Team

An offshoot of the OpenStreetMap project known as Humanitarian OpenStreetMap Team (HOT) was started in late 2009 by Mikel Maron, a map programmer and board member of OpenStreetMap. Positioned in direct response to the need for maps in areas of humanitarian crisis, Maron has organized members from the technology community to visit crisis zones such as Port-au-Prince as well as a long-term presence in Kibera, the largest slum in Nairobi, Kenya. HOT uses the same tools as the wider OpenStreetMap community, and either runs a separate instance of the OpenStreetMap server and database, or directly uploads the data to the main OpenStreetMap.org service. [59]

### OSM Gaza

HOT's first project, a volunteer effort to map the Gaza Strip during the 2008-2009 war between Israel and Gaza, relied on Yahoo Maps and Digital Globe satellite imagery. Over seven days, OpenStreetMap volunteers traced the satellite imagery in order to produce a more accurate, more up-to-date map, and with assistance from JumpStart International, the map was available online and for download with no copyright restrictions. [17] This emphasis on placing map data (not just rendered maps!) in the public domain was intended to enable the widest possible uses of the information, on both a technical and legal basis. In order to preserve this legal status, the OSM Gaza dataset was published separately from the main OpenStreetMap database, though in accordance with its liberal licensing, a copy was uploaded to OSM as well. Building on the success



of the OSM Gaza project, HOT went on to collaborate with a variety of organizations in countries like India, Kenya, and Georgia, all using the OpenStreetMap toolset (see Section 10.1.2).

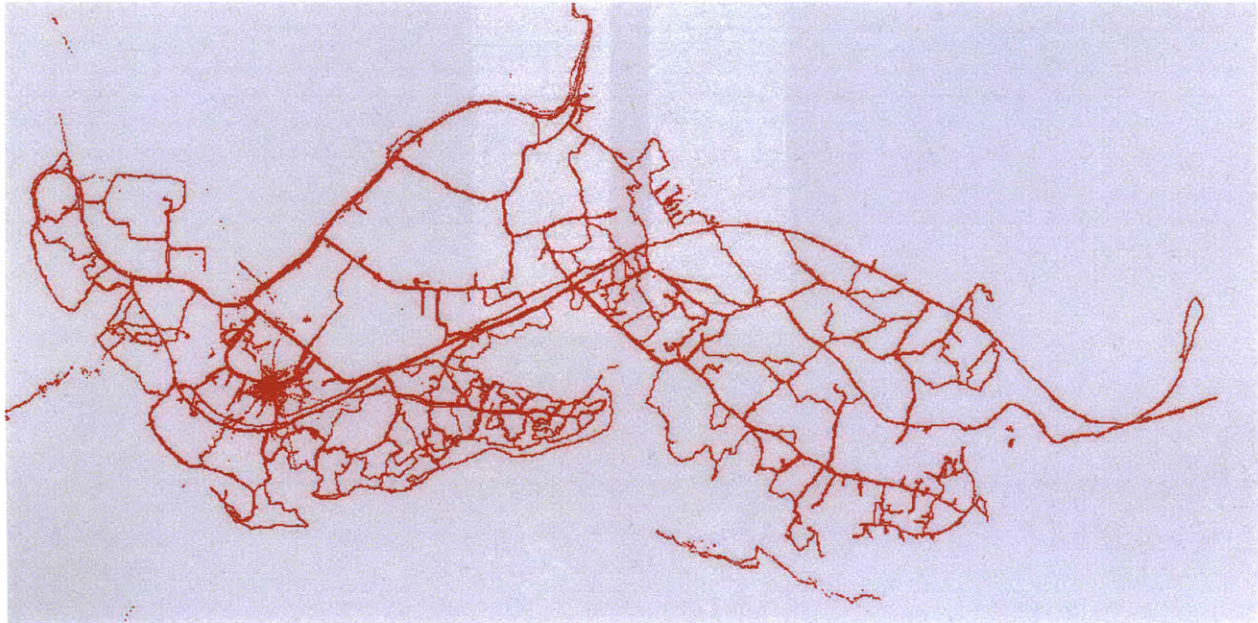

**Figure 5.2:** GPX traces collected from GPS units over three weeks of mapping in Kibera. [http://www.flickr.com/photos/mikel\\_maron/4143021346/](http://www.flickr.com/photos/mikel_maron/4143021346/)

Two projects by HOT stand out as their most ambitious and influential. The first, called simply Map Kibera (<http://mapkibera.org>), produced a map of the famous Kibera slum in Nairobi, Kenya, in collaboration with several local organizations. This project differed from earlier HOT projects in that it relied primarily upon local participants using hand-held GPS units to produce the map, as well as with paper-based map annotations using the Walking Papers system developed by Michal Migurski of Stamen Design. With a specific mission to engage in the sociopolitical aspects of cartography, Map Kibera is much more explicit than OSM Gaza in its agenda and the needs it addressed. It also represented a shift away from remote mapping by means of tracing, towards a model which relied more heavily on local expertise and familiarity with the site. In this sense it has much more in common with the Grassroots Mapping project; both attempt to empower local communities by building local capacity and ceding control over the mapping process to local individuals and organizations.

The second project of note is the mapmaking work done in the aftermath of the January 2010 earthquake in Haiti. While the full extent of crisis mapping work in Haiti is beyond the scope of this document, it is important to note that much of the work of aid organizations in the disaster was supported by OpenStreetMap data — data which was traced from satellite imagery. Mikel Maron writes:

The have been at least 400 OpenStreetMap editing sessions in Haiti since the quake hit. Mostly tracing Yahoo imagery, and gleaning information from old CIA maps. We also just received permission to use GeoEye imagery acquired post-event that will allow us to tag collapsed buildings.

[45]

This dataset has proved essential, not only to the open geodata community, but to larger traditional organizations who were unable to find better maps, prompting some to refer to the Haiti disaster as a ‘sea change’ in the widespread acceptance of crowdsourced geodata. Alan Glennon points out that ‘all the United Nations agencies acting on the ground in Haiti used OpenStreetMap for their print maps’ [30]

This reliance on satellite imagery for crisis mapping demonstrates its ability to rapidly produce maps, but neglects the importance of building local mapmaking capacity and infrastructure. The initial Haiti maps were made entirely without the participation of local residents, due to the urgency of the situation, not to mention internet access issues and the overwhelming willingness of foreign volunteers to help produce maps. As discussed in Section 4.4.1, in the weeks and months following the initial disaster, access to satellite data would prove to be a bottleneck not only for local control of mapmaking efforts, but for everyone involved in the crisis mapping response. Open licensing of new imagery would allow for damage assessment and monitoring of the humanitarian crisis that has unfolded in the wake of the disaster.

## 5.3 Orthorectification

These difficulties highlight the need for an alternative and more inclusive means for sourcing aerial imagery, not only for local communities and activists, but for broader efforts like the crisis mapping and open geodata movements. With this in mind, this section will focus on existing approaches for capturing and processing aerial imagery. While there are a diverse range of approaches to participatory mapping, several prior works have focused, as I have, on building free or widely available tools for orthorectifying aerial imagery as a means to produce and publish mapping data. Their uses range from stitching aerial imagery captured from hobby-level remote control aircraft to rectifying historical printed maps in order to digitize their contents.

### 5.3.1 Map Warper

Perhaps the most ambitious project of this type is the Map Warper software written by Tim Waters, Schuyler Erle, and Shekhar Krishnan, as part of their effort to ‘crowdsource’ the digitization of the New York Public Library map archive. [82] The tool invites volunteers to orthorectify maps by matching Ground Control Points, or GCPs, between a source image and a reference map, and using an automated affine warp (based on the Geospatial Data Abstraction Library (GDAL) open source tool) to produce a composite map.

While designed for warping archival maps onto a vector dataset, namely OpenStreetMap, the tool can be used to warp aerial imagery onto satellite data. This is achieved by inserting a new layer into the reference map pane, which is implemented in OpenLayers. The resulting warped image can be downloaded as a GeoTIFF or accessed as a standards-compliant WMS layer. A more complete discussion of this tool and its applicability toward grassroots aerial mapping can be found in Section 7.2.



### 5.3.2 GonzoEarth and manual stitching with Adobe Photoshop

One of the leading practitioners of low-cost mapmaking today is Stewart Long and his one-man company GonzoEarth, which provides ‘applied neogeographical techniques for on-demand mapping’ [39]. Long is responsible for such impressive maps as the 2009 map of Burning Man, published at a 2 cm resolution<sup>1</sup>. This map was warped onto a lower resolution base map, blended, and output as a BigTiff image, surprisingly using Adobe Photoshop CS4. The image was then reprojected and saved as a GeoTIFF using the open source GDAL package. Long’s use of Photoshop extends to all his mapping work, due to its ability to ‘make dynamic selections, transformations, and stitching’ including layer merging and flattening. [39] While observing his process, I noted that he would repeatedly return to earlier images in order to adjust them iteratively. GonzoEarth maps are among the best available in that they are seamless and consistent, and Long has both patience and a unique intuitive grasp of the process. Careful observations of his work have played a major role in the design of the Cartagen Knitter, described in Section 6.2.2.

The imagery for the Burning Man map was taken from a helium balloon by Jack Alderson, but Long also captures imagery by using a lightweight and relatively inexpensive remote control airplane called the Easystar, sold by the German company Multiplex. A small Canon camera is inserted into the cockpit and a hole is cut in the belly of the plane through which the pictures are taken. Long can fly the plane at up to a half-mile away, steering manually with a 2.4 Ghz transmitter and can capture imagery at hundreds of feet in the air. The plane can remain in the air for up to an hour.

## 5.4 Aerial imaging with low-cost tools

Due to the need for cheap and up-to-date imagery, a major part of the Grassroots Mapping project has been the design and use of low-cost platforms for capturing images of the ground from above. The use of kites and balloons to raise consumer-level ‘point-and-shoot’ cameras has allowed participants to capture images of sites of interest at minimal cost. A Grassroots Mapping Kit can be assembled for less than \$150. This would not have been possible without building upon the long tradition of Balloon Aerial Photography (BAP) and especially the research and careful documentation by more recent innovators in the field. While balloons have been used as a platform for photography since Gaspard Felix Tournachon’s first attempts in 1858 [80], publications throughout the mid-1990s and into recent years by researchers such as Lee Vierling, A. Buerkert, Michiru Miyamoto, and many others, have es-



**Figure 5.3:** Maron jokingly referred to this experiment in KAP as the ‘first Palestinian spy satellite’. [41]

<sup>1</sup>View the map online at GigaPan.org: <http://gigapan.org/gigapans/46290/>

tablished a diverse set of techniques and use cases for such imagery. Similar examinations of KAP techniques by James and Susan Aber and others, have led to the coining of the term **Kiteography** — defined by Vierling as the use of KAP for ‘making large-scale topographic maps, based on photogrammetric principles.’ [80] In general, the existing research has emphasized the low cost and high resolution of resulting data, and most researchers have focused on its applicability to environmental assessment. [2][1][51][10]

Of particular interest is Eric Wolf’s thesis on the use of BAP for ‘necrogeography’, or the mapping of cemeteries, where he examined the accuracy and precision of various approaches to orthorectification.<sup>2</sup> as well as in comparison to high resolution readings from a differential GPS. Wolf has been generous in contributing advice and even equipment to the Grassroots Mapping project. Also of note are Mikel Maron’s attempts to use kites to produce maps in Palestine [41] with KAP techniques. However, few of these prior works have addressed the challenges in facilitating the adoption of such tools by non-technical participants, or in their potential to provide high quality map data to those without proficiency in GIS technologies.

#### 5.4.1 DIYDrones.com and the T3 competition

One notable use of autonomously piloted model aircraft which holds much promise for the future of low-cost mapping is the 2009 DIY Drones Trust Time Trial (T3) event, where enthusiasts of autonomously piloted model aircraft were put through a series of successively more difficult tasks such as flying a complex route. The competition’s Round 4 event, entitled ‘Map a quarter-kilometer!’ challenged participants to photograph a 500 meter square from their aircraft, and to submit a KML of the route as well as a stitched map of the target area. Seven entrants from five countries completed the round, using a variety of autopilot systems and airframes. [6] The complete costs of such kits ranges from approximately \$1,000 upwards, but as the cost of this type of equipment drops, this may be an increasingly viable means of capturing aerial imagery. At the same time, it is important to remember that these are essentially adaptations of military technology, and local context must be taken into account — in many places, such as the West Bank, remote controlled aircraft may be unwelcome or perceived as threatening both by local communities and regional military or law-enforcement agencies.

The techniques I have refined in my own work have built primarily upon precedents in balloon and kite photography. I have striven to further simplify the assembly of a working kit, and attempted to devise methodologies for effective teaching of the techniques. In addition, I have worked with others to push the limits of balloon and kite mapping in terms of altitude, resolution, speed of capture, and ease of image processing and map publication. These improvements will be discussed in the following chapter.

---

<sup>2</sup>See Section 6.2.2 and Section 9.3.1



## Chapter 6

# The Grassroots Mapping tool chain

### 6.1 Balloon and Kite Aerial Mapping

As discussed in Section 5.4, prior works in kite and balloon mapping make it redundant to discuss the advantages of such techniques beyond to say that they are easier and less expensive than aircraft or satellite-based imagery sources. However, the particulars of the equipment designed for Grassroots Mapping projects have emphasized yet lower cost, ease of use, and ease of reproduction than many existing designs, and a discussion of these decisions is relevant.

Due to the distinct compromises of each technique, I recommend that those attempting to capture aerial imagery equip themselves to use both balloons and kites. Luckily, the techniques share much of the same equipment, and it is possible in many places in the world to assemble a basic but complete kit for under \$150. I have done so in surprisingly unlikely locales, such as the West Bank in Palestine, Lima, Peru, and Kutaisi, Georgia.



#### 6.1.1 Balloon mapping

Helium is a limited and non-renewable resource, and obtaining it in the quantities necessary for aerial photography can prove challenging in the more remote parts of the world. 250 cubic foot tanks are most common, but are too heavy to carry without a wheeled dolly, and do not easily fit into cars or buses. They are also excessive, providing enough helium for between six and ten flights with a typical payload. If available, 80 or 120 cubic foot tanks are preferable, typically sold in the United States for \$45 and \$60, respectively. Those constructed from aluminum are especially convenient, being far lighter and easier to transport. Costs vary, depending on the distance from

**Table 6.1:** Comparison of balloon and kite mapping techniques. Despite the challenges and higher costs of balloon mapping, typical extents of a balloon map are far greater due to the higher altitude of flight, and due to a balloon's tendency to fly vertically in low winds, it is much easier to image the correct area. In the largest Grassroots Mapping project in the Gulf of Mexico, more than 60% of maps to date were made with balloons, and kite flights have typically had a much lower success rate.

Type	Kite	Balloon
<b>Altitude</b>	300m	1400m
<b>Extent</b>	several hundred meters	>1km is common
<b>Control</b>	hard to target imagery - difficult in winds <45kph or <10kph	very fine control on windless days - difficult in winds >10kph
<b>Payload</b>	<2 kg	<300g
<b>Time constraints</b>	best winds in early afternoon	lowest winds at dawn
<b>Portability</b>	foil kites pack down to 1 liter size	helium tank and fragility of balloon limit portability, access
<b>Tether angle</b>	poor, camera altitude as low as 1/5 of tether length	in windless conditions, flies vertically; very sensitive to wind
<b>Durability</b>	excellent, no consumables	very poor; balloons pop regularly
<b>Cost per flight</b>	none	\$15-35 per flight dependent on helium costs
<b>Initial total cost of kit</b>	\$100-400 depending on kite and tether material	\$150-500 depending on choice of balloon and tether material

**Table 6.2:** Comparison of balloon type options

Type	Cost	Typical # of uses	Permeability
5-foot polyurethane advertising balloon <sup>1</sup>	\$140	hundreds?	Deflates 1-3% per day
8-foot <sup>2</sup> latex weather balloon	\$25	up to 10 if careful	remains inflated for several hours; this weakens the balloon
Trash bags	\$2	2-3	1-2 days if thicker (3 mil) plastic is used

<sup>1</sup> Available from Southern Balloon Works, [southernballoonworks.com](http://southernballoonworks.com)

<sup>2</sup> '8-foot' denotes burst diameter, actual filled diameter during use is approximately 4 feet

major helium sources such as the United States and Russia, but I have found large, 250 cubic foot tanks available for rental at approximately \$250 each in Bethlehem, in the West Bank, and for approximately \$300 in Lima, Peru, both at party stores. Gas supply vendors may offer somewhat lower prices, but sometimes require a permanent customer account, and can be reluctant to rent to non-industrial customers.

To further reduce costs, it is possible to use large high density polyethelene trash bags, of the kind typical worldwide. Two extra-large ninety-nine gallon bags suffice to lift a small camera and string to thousands of feet. Bags may be sealed shut with tape and filled without modification, or cut open and reassembled into tetrahedral shapes to minimize the surface area to volume ratio and provide greater lift. In addition, trash bags may be left inflated for several days without stretching or damaging the plastic, unlike latex balloons. However, helium leaks slowly through the plastic, and even relatively thick 2.7 mil plastic bags will lose most of their lifting power after a day or two. Trash bags are available for less than a dollar anywhere in the world, as is the clear plastic packing tape which may be used to seal them closed.



**Figure 6.1:** Testing trash bag balloons with the Department of Play working group on the MIT campus in Cambridge, Massachusetts.

### 6.1.2 Kite mapping

Kites present an opportunity to loft cameras at near-zero cost — materials for making kites can be found for less than a dollar, or recycled from waste. However kites can be particularly challenging to fly stably and difficult wind conditions often make for a frustrating and exhausting day of attempted



mapmaking. With this in mind, I have looked to the experience of **KAP** enthusiasts in choosing a respected standard in highly portable, reliable, and flexible flight: the Sutton Flowform. This ‘sled kite’ has no rigid spars and even its 16 square foot model can be packed down to fit in a small sack. Flowforms can be flown at a wide range of wind speeds and the Flowform 16 can lift tens of kilograms in ideal conditions. However, its \$100 cost makes it somewhat beyond the means of many map makers. Therefore, whenever possible I have encouraged my collaborators to apply local traditional kite designs, often with great success. In Lima, Peru and Ramallah, Palestine, local designs were cheap and effective, the only issue being that they had to be scaled up to a size which could lift the approximately 300 gram payload. Kite building makes for an engaging and fun activity while reycling on local means of production for an aerial platform.

### 6.1.3 Camera and intervalometer

Throughout the design of the Grassroots Mapping Kit I have emphasized low cost; therefore, taking a note from the page of low-cost aerial photographers like Oliver Yeh of [1337arts.com](http://1337arts.com), I recommend an inexpensive ‘point-and-shoot’ camera, ideally of Canon’s A or SD lines (the SD series is sold under the brand IXUS in Europe). While these tend to be in the 7-12 megapixel range, they are typically only 200-300 grams and are durable and compact. Such cameras can be found second-hand on [eBay.com](http://eBay.com) for as low as \$50. Despite resolution, lens choice and stabilization advantages of more expensive models, consumer-grade compact cameras of this sort are widely available, and their image quality is sufficiently high that they make a good balance of weight, image quality, and cost — the latter being of especially high importance since we have occasionally lost entire kits due to accidents such as improperly tied knots or sudden immersion in water.

Consumer-grade Canon cameras also benefit from the active open-source hacking community’s efforts to provide an alternative firmware with advanced features such as scripting. The Canon Hacker Development Kit (**CHDK**), which is stored on the camera’s SD memory card, makes possible a script which I have adapted to trigger image capture every 5-10 seconds. The script, referred to as an intervalometer, is available for download at <http://wiki.grassrootsmapping.org/show/BalloonAerialPhotography>. Alternatively, many participants have found it easier to set their camera to ‘continuous mode’ and hold down the trigger button with a rubber band. This captures an image must faster; typically once per second, filling up the memory card and using more battery power. However, it has the benefit of simplicity, and of working with almost any brand of camera.



**Figure 6.2:** César, a **CEDRO** student, completes a kite of his own design in Juan Pablo II.

**Table 6.3:** Balloon mapping kit pricing

Mid-range estimate		Minimum estimate	
8 ft diameter weather balloon	\$30	2x100 gallon trash bags	\$3
2000 ft. nylon string	\$50	2000 ft. nylon string	\$24
cotton string, duct tape, packing tape, rubber bands	\$20	cotton string, duct tape, packing tape, rubber bands	\$10
Soda bottle, cardboard	\$2	Soda bottle, cardboard	\$0
Scissors	\$8	Scissors	\$2
Camera	\$80	Camera	\$50
Clips etc.	\$5	Helium	\$55
Helium	\$55		
Total	\$250	Total	\$144

**Table 6.4:** Kite mapping kit pricing

Mid-range estimate		Minimum estimate	
Sutton Flowform 16	\$110	Trash bags & sticks	\$3
1000 ft 200 lb dacron or spectra string	\$50	1000 ft nylon string	\$20
Kite reel	\$20	Soda bottle, cardboard	\$2
Soda bottle, cardboard	\$2	Scissors	\$2
Scissors	\$8	Camera	\$50
Camera	\$80	Clips etc.	\$5
Clips etc.	\$5		
Total	\$275	Total	\$99



### 6.1.4 Enclosures and suspensions

In order to attach the camera to the balloon or kite, KAP enthusiasts typically make use of a ‘Picavet suspension’, an arrangement of one continuous string on a series of rings or pulleys. This has the exceptional ability to keep the camera level and relatively stable even in turbulent conditions. However, experience in Peru<sup>1</sup> showed that constructing a working Picavet and maintaining it without tangles can be difficult, especially under adverse conditions such as long crowded bus rides, limited construction materials, and excited young participants. In the light of these challenges I have developed a more basic but still serviceable alternative called the ‘Soda Bottle Rig’ which as an added feature protects the camera from light impacts. The basic design can be seen in Figure 6.1.4, and includes a pair of ‘wings’ placed approximately 30 degrees apart, which serve to stabilize the enclosure against the wind, reducing radial blurring in the aerial images.

The soda bottle rig is convenient to carry, and makes immediate visual sense to observers, unlike the confusing array of crossed strings in the Picavet. The additional swaying of the Soda Bottle Rig in fact results in greater extent in the resulting maps, though resolution drops dramatically as photographs become more oblique. This does allow map-makers to decide whether to sacrifice consistent resolution in favor of a larger extent, however. In addition, while it works well for the typically horizontal tether of a kite, the Picavet suspension is rendered largely useless on a vertical tether, as the two mounting points are placed inline, one above the other. The Soda Bottle Rig has been used through the BP oil spill mapping project described in Chapter 8. Still, experienced aerial photographers may achieve better results with the Picavet suspension in kite photography.

## 6.2 Map processing and publication

Once aerial imagery is captured, software must be used to distort or ‘warp’ the photos and combine them to fit a projection. This essentially maps every pixel of the source imagery to a corresponding position on the earth’s surface, allowing for correlation to other maps and sources of geodata. As no existing tool has so far met all of the design requirements I had compiled from the pilot project in Lima, Peru — such as cost, ease of use, low barrier to entry, and performance (see Section 5.3) — I developed a unique tool and associated mapping framework with the goal of making DIY cartography simpler, cheaper, and more inclusive.

---

<sup>1</sup>See Chapter 7

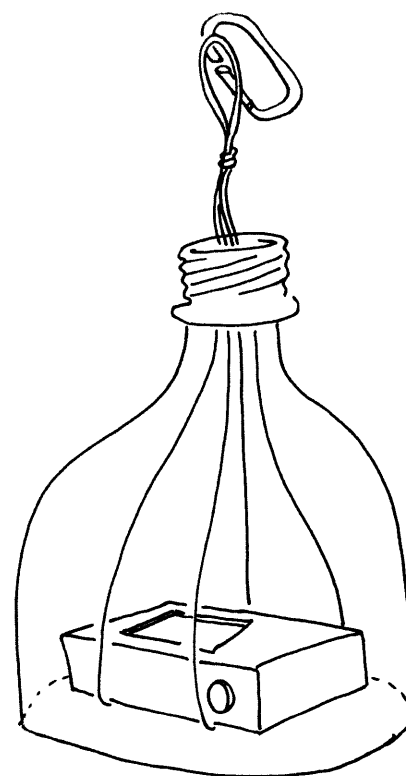

**Figure 6.3:** The Soda Bottle Rig

### 6.2.1 Web-based orthorectification and warping

The collaborative mapmaking process conducted in Lima in January 2010 demonstrated that the primary barrier to producing map imagery was the orthorectification process. While in Lima, participants made use of Adobe Photoshop CS4 as well as the Map Warper software discussed in Subsection 5.3.1. Attempts were made to instruct residents in the use of these tools, but were met with limited success due to the limited availability of computers powerful enough to run Photoshop, latency in internet access, and most of all, the obscure interfaces which users were required to learn.<sup>2</sup>

### 6.2.2 Cartagen Knitter

The Cartagen Knitter software, developed in the months following the project in Lima, makes this possible. Using the Cartagen framework along with an HTML 5 distortion technique prototyped by Steven Wittens of <http://acko.net> [84], I created an interface for users to upload images as overlays on an existing base map, typically OpenStreetMap vector data or a source of existing satellite imagery. Users then manually distort an image by dragging the corners with the cursor. Tools for rotating, scaling, and adjusting the transparency of images were added, and the tool was tested and refined in a variety of workshops and mapping projects over several months.

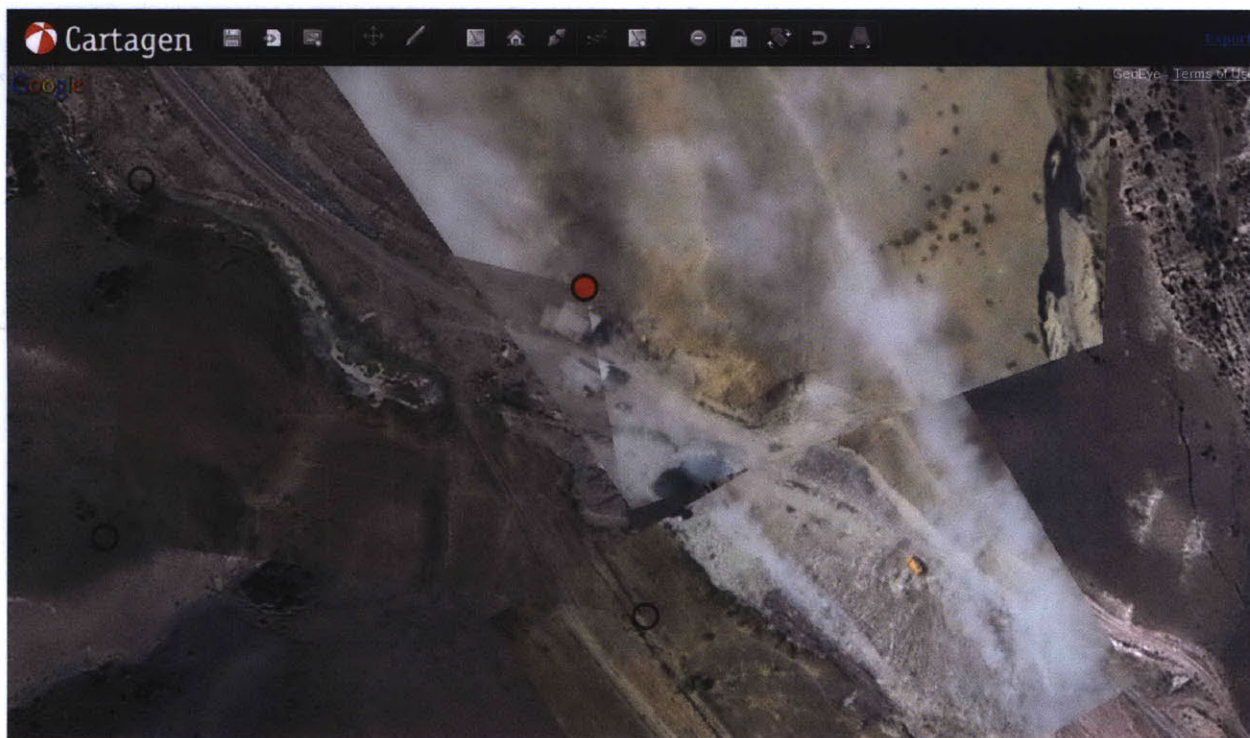

**Figure 6.4:** Warping aerial imagery over a base layer from Google Maps. The imagery was captured with students and OpenMapsCaucasus staff in Rustavi, Georgia, using kites. Note that imagery orthorectified against Google satellite data may be considered a derivative work; a base layer available under an open license is preferable.

---

<sup>2</sup>See further discussion in Section 7.2

Cartagen Knitter makes several unique choices about how users orthorectify imagery. The first is that it emphasises orthorectification of individual images against a base map, rather than initial stitching of images into a larger composite image and subsequent orthorectification and warping of that larger image. This decision was based on the relatively high computing resource requirements of manipulating a single higher-resolution image, given Knitter's emphasis on low-resource usage. Additionally, Eric Wolf of the US Geological Survey has found experimentally that the composite, or mosaic, technique suffers from a loss of accuracy. His analysis demonstrated a loss of accuracy of 'nearly 100% in both location and orientation'. [85]

The second design decision which may seem curious is the emphasis on a completely manual orthorectification interface: no automated interest point finding or matching is used, despite the availability of such software (i.e. Hugin, Photosynth, Vision Workbench, etc.). Even Map Warper automatically warps images using the **gdalwarp** utility, though it asks users to identify ground control points to determine how to perform the warping. In practice, however, the use of such automated techniques did not result in good mosaic images, nor was the process of stitching, warping, and orthorectifying easy to understand or troubleshoot for non-technical users. Hugin provides for rectilinear warping, which does not assume a fixed camera position, but in order to successfully apply this configuration in the graphical user interface requires a 'hack' and existing documentation is either unclear or obsolete. Additionally, desktop programs such as hugin or Photosynth may be difficult to install in an internet cafe, which users in Lima might find necessary.

### 6.2.3 Rubbersheeting

The manual orthorectification process is based on an interface paradigm known as 'rubbersheeting', due to its similarity to physically stretching rubber sheets over a reference map. The distortion used in Cartagen Knitter is technically known as a projective warp, unlike the polynomial 'affine warp' employed by Map Warper, or the simple stretching used by Google Earth. While considerably more computationally intensive than a first-order affine warp, the projective warp results in an exact mapping of four corners of the warped image to latitude/longitude coordinate positions. By contrast, Google Earth can only exaggerate the height and width of an image, while Map Warper attempts to find a best fit, accepting measurable inaccuracies in the placement of each point. While affine warping can compensate for spherical distortions such as lens effects, in practice, it was difficult and frustrating for users to place control points which did not actually bind a position in the warped image to a position in the base image. Many users attempted to compensate by placing deliberately incorrect control points. [9]

Direct placement of the four corners of an aerial photograph on a base map was a much more direct means to orthorectify images. While this does not allow for spherical or nonlinear distortions, future versions could accommodate further subdivision of an image into a triangulated mesh; this would allow for more subtle adjustments of the interior of an image without disturbing the positioning of the outer edges of the image. Additionally, known lens geometry, extracted from Exchangeable Image File Format (EXIF) data, could be used to reduce lens distortion automatically.

The resulting interface was both easy to explain to users and faster than alternatives. Non-technical users and even children have used the Cartagen Knitter to produce large maps in just a few hours, and the export feature added recently has enabled finished maps to be saved in the GeoTIFF and TMS standards, and viewed in common tools such as JOSM, facilitating integration into existing workflows.



## 6.2.4 Cartagen: an alternative architecture for digital maps

Beyond the ability to orthorectify imagery, Cartagen is a fully-fledged cartographic scripting environment and renderer. It can draw vector data onto a pixel grid at over 10 frames per second on most computers, and follows the conventions of an animation framework rather than the more static assumptions of the typical mapping system. As the user interacts with a Cartagen map, features are updated and drawn continuously. This negates the need to cache or otherwise store raster representations of map data, and sidesteps many of the assumptions and limitations of the modern mapping software stack. This alternative geostack is one of the most unique aspects of the Grassroots Mapping tool chain, and is also what makes possible the rapid feedback loop of the Cartagen Knitter, as there is no ‘render’ or ‘warp’ step — the effect of the user’s orthorectification is visible in real time.

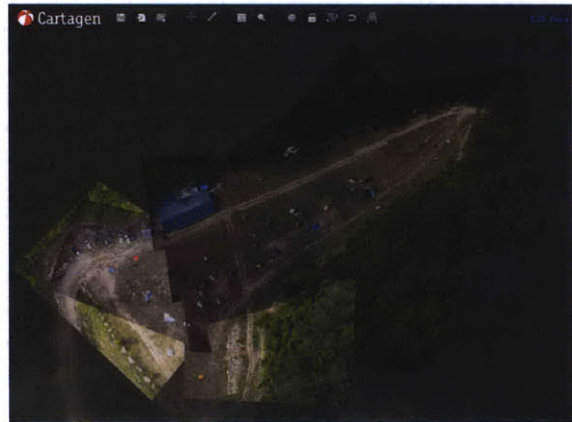

**Figure 6.5:** A map of Wiley’s Last Resort in Kentucky, produced in Cartagen Knitter with imagery captured from a remote controlled aircraft by Stewart Long.

### Dynamic local rendering

As discussed in Section 5.2, most digital maps today employ a server-side caching mechanism providing a tiled image collection. The tiles are assembled seamlessly in the user’s browser, and zooming is accomplished by maintaining multiple tilesets — one for each zoom level. The resulting system scales predictably, as tiles do not vary dramatically in file size, and can be served using a standard web server such as Apache, or even stored locally for offline use. While this works well for a single dataset, it commits the map to a single representation. Multiple tile sets can be stacked, and polygons can be overlaid, but the end user cannot edit the tiles or manipulate the data they contain — the map is essentially static. Compressing data into tiles strips them of their metadata and authorship information in favor of scalability and consistency, but such a tradeoff may no longer be necessary. For companies such as Google or Yahoo, this represents a form of control over the map data; instead of distributing the source data, their use of tiles protects their intellectual property from re-use or adaptation.

I designed Cartagen to sidestep many of these requirements, and to allow users to participate as first-class citizens in the authoring of maps. Using new techniques made possible by widespread browser support for HTML5 and specifically the Canvas element, Cartagen can create maps which are not pre-rendered, but generated on-the-fly. This frees the map from a single projection or representation, and enables a more dynamic, interactive, and narrative cartographic style. Discrete vector data (made up of points, lines, and areas) is downloaded in JSON format just once, and displayed at any scale and in any style. HTML5 adoption in open-source web browser frameworks such as WebKit, along with recent dramatic increases in JavaScript execution speed makes this local rendering possible, and eliminates the need for browser plugins like Flash or Java. This makes



dynamic mapping possible even on mobile devices such as on the iPhone, Android, and Windows Mobile platforms, many of which implement these new standards.

As an added advantage, Cartagen performs much of the computation of map rendering and display locally, reducing dependence on high-latency internet connectivity. It also allows users to easily download data and view or edit it offline. These features make it particularly appropriate for use in developing countries or in crisis situations. When multiple users access a map simultaneously, an additional benefit is that any number of users may edit simultaneously — a feature which has dramatically accelerated the speed of stitching a map in field tests.

### Cartographic design with Geographic Stylesheets

Though other mapping frameworks such as OpenLayers have made use of the canvas element as well as other alternatives such as Scalable Vector Graphics (SVG), Cartagen was among the first to appropriate the ‘content vs. style’ paradigm of HTML/CSS, in order to allow users to style maps using a simple CSS-like syntax, known as GSS. This took advantage of Cartagen’s live-rendering ability to render features in response to simply defined, tag-based style definitions. Cartagen is one of the most easily customizable map rendering frameworks, and is specifically designed to leverage widespread literacy in HTML/CSS, thereby lowering barriers for those interested in using geospatial design tools.

```
leisure: {
  fillStyle: "#2a2",
  lineWidth: 3,
  strokeStyle: "#181"
},
park: {
  fillStyle: "#2a2",
  lineWidth: 3,
  strokeStyle: "#181",
  pattern: "images/pattern-water.gif"
},
coastline: {
  strokeStyle: "#57d",
  lineWidth: 20
},
highway: {
  strokeStyle: "white",
  lineWidth: 7
}
```

**Figure 6.6:** An example GSS stylesheet, demonstrating the simple syntax it uses to specify map styles.

### 6.2.5 Architectural advantages of the Cartagen framework

As a fully scriptable cartographic environment, the Cartagen framework was uniquely suited for building an image orthorectification tool. The Canvas element is essentially a pixel raster, but because Cartagen’s primitives are vector objects stored as points and polygons, there is no need to resample source imagery while performing distortions or transforms. Resampling and compositing occurs only once a map is completed and exported, reducing data degradation due to repeated resampling. While in Photoshop, a powerful computer is required to store, manipulate, and export

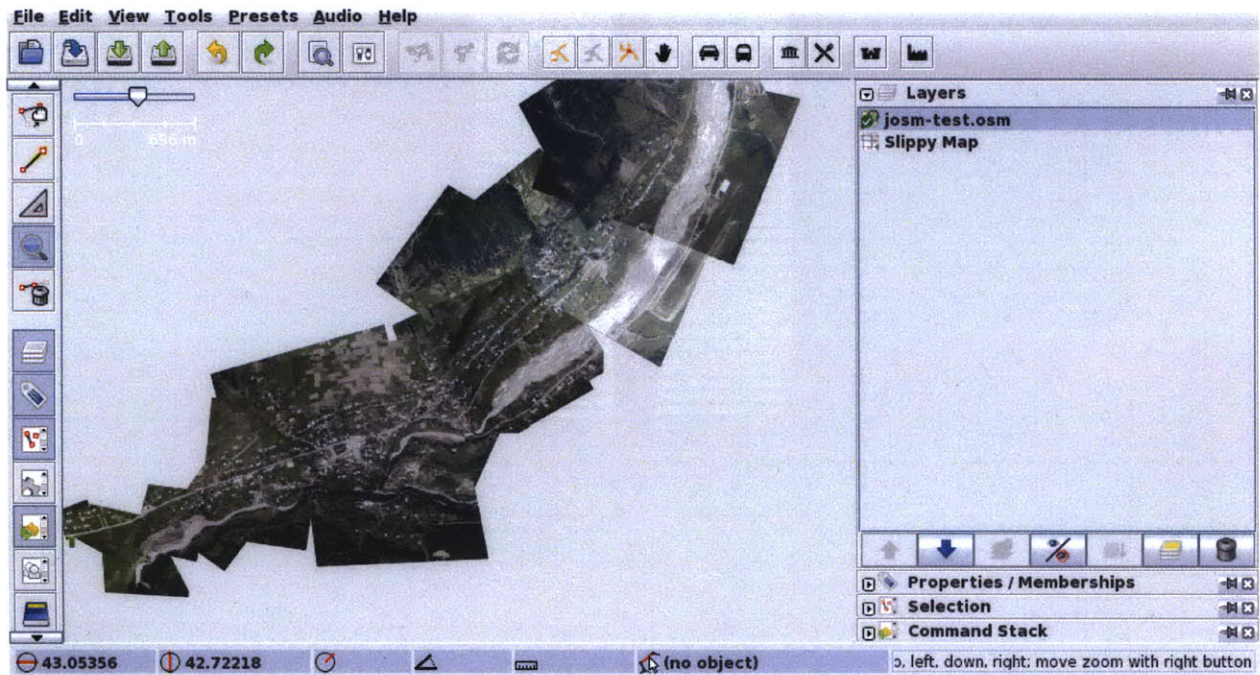

**Figure 6.7:** Viewing output from the Cartagen Knitter in JOSM for contribution to the OpenMap-Caucasus project in Georgia. Read more in Section 10.1.2

a map of any considerable size<sup>3</sup>, Cartagen can be used to stitch maps using a laptop or even a low-power netbook. While editing, users see a lower-resolution preview rendered only at the size of their browser window. The final, high-resolution composite image is exported using ImageMagick on the server side. This lowers the cost of the equipment to process and orthorectify aerial imagery by thousands of dollars.

In a sense, rendering is at the heart of the argument for participatory cartography. If mapping is to be a means to advance an agenda, develop a narrative, or create a communal self-image, it must allow for diverse forms of representation. We have the divergent data and the means to collect, collate, and publish it what we lack is a way to represent it in layered, interactive, and radical new ways. Cartagen's unique architecture allows it to describe a constantly changing data set with both technical and epistemological consequences. Once maps are rendered in the browser window instead of by Google or Yahoo, users are empowered to design, interpret, manipulate, and publish that data in new and compelling ways.

### 6.3 An iterative and collaborative approach to tool design

In order to develop tools which respond well to user needs, I employed a collaborative process, testing various tools in a variety of contexts. Combinations of tools were tested with participants from Lima, New Orleans, and Rock Creek, West Virginia. Interviews and notes were used to develop new tools which built on the strengths of existing off-the-shelf systems such as Photoshop,

<sup>3</sup>Some maps produced during the BP oil spill project were over 50,000 px in each dimension



Hugin, and Map Warper. The same is true for the physical tools such as the balloon and kite kits, including the camera housing, reel construction, and auto-triggering setup.

In the case of the camera housing, Grassroots Mapping community members have iterated and improved upon the soda bottle enclosure, discussing and testing alternatives on the mailing list, and even posting videos of tests. Pat Coyle, a mailing list member, published a narrated demonstration of a soda bottle enclosure with improvements such as a window to access the camera controls and a small bungee cable to stabilize the camera against the inside of the bottle. In another example, Mathew Lippincott prototyped solar-powered hot air balloons constructed from painter's plastic sheeting, conducted pigmentation and lift tests to determine suitability for carrying cameras. The tests and builds were held at a public event in Portland, Oregon, and videos and instructions were posted online.

My own regular testing of new tools at the MIT campus, as well as repeated attempts to orthorectify the resulting imagery, grounded the software development in concrete usage and experience, and a workshop at the Google campus in Mountain View in April 2010 included a collaborative hacking session aimed at identifying and resolving bugs and adding new features in direct response to the day's mapping efforts. As development of the Cartagen Knitter software progressed, mailing list members with a variety of needs chipped in with suggestions, bug reports, and feature requests, including the ability to lock images when finished warping, revert to original image proportions, and use keyboard shortcuts for common commands. Combined with test flights and experimentation by active community members such as Pat Coyle and Mathew Lippincott, the tools have progressed from partially functioning prototypes to relatively mature technologies with understood abilities and limitations. It was the multiple deployments of the tools in the Lima, Peru and BP oil spill case studies, however, which put them to the test in real-world applications, and forced us to push the tools' abilities to their limits.



**Figure 6.8:** Still frame from Pat Coyle's demonstration on YouTube [20]



**Figure 6.9:** Mathew Lippincott leads a workshop entitled 'Grassroots Mapping PDX' where participants constructed and tested solar and helium balloons made of plastic sheeting, for use in the Gulf of Mexico.

## Chapter 7

# Case Study: Grassroots Mapping in Lima, Peru

### 7.1 Introduction

In the interest of basing tool development and design on real-world applications, and due to an ongoing conversation with Carla del Carpio of Lima-based Manzanita 'A', I travelled to Lima, Peru in January 2010 to work with residents of several informal settlements and a number of NGOs on Grassroots Mapping projects. From the start, this was considered an experimental program, where Peruvian collaborators would help to better define needs and to iterate and improve upon the balloon and kite imaging techniques.

The program was also explicitly educational in its goals, and with educators from Lima-based CEDRO and Manzanita 'A', a curriculum was developed to involve local youth in the map-making process. We placed emphasis on examining the cartographic process with students not only in the sense of recording the present layout of students' communities, but with the intent to depict and discuss geography in the context of their history and future. We devised a series of exercises were devised to situate mapping as a way to examine and reflect upon rapid urban growth and participatory urban planning such as occurs in the partner communities.

This alignment of mapmaking with education and youth empowerment was not new to the project, but for the first time it was one of the primary goals. Mappers often ask me why I work with kids; educators, on the other hand, rarely ask why I focus on mapping. To answer the former, one of the main reasons is that kids are



**Figure 7.1:** Children capturing aerial imagery in Canta Gallo, Lima, Peru.



good mappers. They represent a wealth of knowledge about the very details of a community which adults are likely to gloss over. They have the attention span, the patience, and the enthusiasm, and are often more open-minded and creative than their adult cartographic colleagues. They bring a unique point of view to mapmaking, taking less for granted about their geography, and stand to learn a great deal from such a combination of the physics of flight, the mathematics of cartography, the history of urban development, and the political implications of their physical world. Roger Hart emphasizes in ‘Children as Community Researchers’ the potential for children to ‘learn to see themselves as competent and confident members of their community’, pointing out that ‘Children and adolescents appreciate the opportunity to feel that they can play a useful role in community or environmental improvement.’ [34]

Making maps of such quality and utility with school children also highlights the ease with which such maps can be made to skeptical adults, and pragmatically speaking, it can be hard to use balloons and kites in any populated area *without* including kids, as they usually come out of the woodwork, eager to participate. Finally, there is a sense that everyone becomes a child when flying balloons and kites, and certainly the presence of a large group of eager kids tends to ease the inhibitions of curious adults, encouraging them to loosen up and take part in the fun.

The selection of Lima as a site for prototyping and collaboration was also due to its history of informal settlement, and the project was intended to provide easy and inexpensive alternative means for communities to produce maps specifically for tenure claims. My colleagues in Lima and I believed that it would be possible for partner communities to submit such maps to the relevant authorities<sup>1</sup> as part of official petitions for land title. However, we felt that this agenda should be secondary to the educational goals we established, and to emphasize the benefits of process over end product. Further discussion cemented our belief that as non-residents — who would not be affected by the legal outcomes — it was not our place to aggressively advocate such uses.

### 7.1.1 The Other Path: Lima’s history of informal settlement

Lima’s history made it an especially suitable choice for participatory mapping on a cultural level as well, as it has expanded over the last century to include a full third of the population of Peru, in what has become a process of continuous and transformative growth. The result is a city in which large tracts of land have been settled ‘extralegally’, a term borrowed from Hernando de Soto’s exhaustive history of the city in ‘The Other Path’. These settlements are known locally as ‘invasions’ due to their inhabitants’ sense of having not only literally seized the land from private landowners or the government, but of having unilaterally constructed a working alternative to the official municipal government, including public works, tax collection, and education. These communities, typically made up of only a few hundred people, are truly independent from the central government, and only through a years-long process are able to gain title to their land along with basic services such as plumbing and electricity.

De Soto paints a picture of a government and bureaucracy entirely overwhelmed by floods of immigrants from rural areas, and entirely unable to accommodate these newcomers in a coherent or efficient legal process. ‘We appear to be witnessing’, he writes, ‘the most important rebellion

---

<sup>1</sup>An organization known as Organization for the Formalization of Informal Property (COFOPRI), whose mission is to ‘Execute the creation of property rights such that they provide sustainable, judicially secure ownership titles.’ (‘Ejecutar las acciones de generacin de derechos de propiedad predial que otorguen seguridad jurdica permanente y que sean sostenibles en el tiempo.’) [18]

against the status quo ever waged in the history of independent Peru.’ The numbers are stunning; even at the time of his writing in 1987, he describes in detail how ‘...through invasions or illegal acquisitions of land, neighborhoods sprang up which today account for 42.6 percent of all housing in Lima and are home to 47 percent of the city’s population.’ [23]

This situation, though not unique in the world, is especially appropriate as a place to attempt a mapping project which acts both outside of traditional cartographic means of production, and outside the conventional framework of GIS. In the months that followed the Lima project, I began to refer to the tools and techniques which were prototyped in Lima as a ‘DIY satellite’, and that seems fitting given that in the invasions of Lima, residents are accustomed to Doing Everything Yourself, from constructing roads to building and maintaining their own plumbing. In addition, any means to reduce the barriers to acquiring tenure is of high value; de Soto’s research shows that the market value of a plot of land increases ninefold when its owner receives official title. As in many urban slums worldwide, most residents do not have a bank accounts; the home itself represents the primary means of storing wealth. Land title therefore becomes a form of valuation, and makes it possible to sell one’s plot, or use it as collateral for a loan. More than anywhere else, cartography is inextricably connected to basic systems of value in the invasions, making them an exciting place to test a more participatory means of making maps.

Additionally, we identified a number of more immediate applications for an up-to-date map. Both CEDRO and Manzanita ‘A’ looked forward to using maps for research and planning purposes for their ongoing projects in the settlements. The maps could also be used to support decision making amongst community leaders, for public works projects, land use discussions, and even for promotional purposes. Simply providing another means for community members to gain access to a map would allow them to compare it to the ‘official’ version, or to independently verify that the community was in fact built to their agreed plot divisions. Finally, the process of making the map would build literacy in cartography and give participants more say in how their community is represented to the outside world.



**Figure 7.2:** Measuring homes with a paper measuring tape in Juan Pablo II, Lima, Peru.

## 7.2 Mapping with Juan Pablo II

Both Manzanita ‘A’ and CEDRO were enthusiastic about the potential of a mapping project from the outset, and Carla del Carpio coordinated with CEDRO’s Ernesto Fernandez to set up a 6-day program, or ‘Projecto Integral’ with a group of approximately a dozen students in the Juan Pablo II settlement in Lima’s Villa el Salvador district at the south end of the city. Each day of activities, held between January 12 through 28th, lasted from 11am until approximately 3pm. 4-6 CEDRO



instructors and 2 from Manzanita ‘A’ attended, and the students ranged from 8 to 14 years old. The Juan Pablo II community consists of approximately 6 blocks of homes arranged in a loose grid, though this was not apparent from the Google Maps imagery, which we dated to approximately 2006, or 4 years earlier. The community was 5-6 years old, and many but not all of the students remembered when their families had first come to the site.

We began the workshop with an introduction to map making, by asking students to work together to draw their community. This resulted in a variety of means of representation, though as we continued to discuss maps, they tended toward a birds-eye view. Even then, some experienced difficulty in collaborating on a drawing at a common scale, with some adjustments and redrawings occurring once each student’s map intersected their neighbor’s. An attempt to show the existing Google Maps imagery and to ask students to identify their homes or even the entire community in a map were not successful; the maps did not seem relevant to participants, as most students seemed not to have a high degree of computer literacy or exposure to the internet. Next, students enthusiastically constructed measuring tapes and we broke into groups to literally measure the homes.

### First flights in Juan Pablo II

Interested in quickly capturing aerial imagery and moving on to analysis, we begin flying balloons on the 14th of January. Four balloons, each approximately 3 feet in diameter, were attached to a Picavet suspension (see Subsection 6.1.4) and launched on a 500 foot tether of nylon kite string. Winds of over 10 mph prevented us from capturing many images from high altitude, and frustratingly, this continued to be the case for several subsequent sessions.

Involving the students as full participants, or actors, in the process was also difficult, as only one or two people could hold the balloon at a time, and it required several minutes of experience before students were confident enough to reel the tether on their own. Juan Pablo II is located on a southward facing hillside, and the kites flew at a very shallow angle — close to the ground — as wind blew northward over the ridge. We attempted a variety of kites and launch locations.

On the 26th, after several more attempts with both balloons and kites, we captured several useable images of the community, and together with Carla del Carpio and Ysabel Luisa of Manzanita ‘A’ I stitched together the images into the best and most up-to-date map yet of Juan Pablo II.



**Figure 7.3:** Initial balloon flights in Juan Pablo II.





**Figure 7.4:** Completed balloon map of Juan Pablo II, produced with Adobe Photoshop CS4. The map is overlaid on imagery from Google Maps for comparison.

### **Situating mapping practice**

Establishing a rapid feedback loop with participants is of paramount importance, especially when they are dependent on external aid for part of the mapmaking process. In Juan Pablo II, the lines between ‘researcher’, ‘cartographer’, and ‘participant’ were blurred, as all parties were learning to create maps together in a novel process. Throughout the flights, we made regular prints of the aerial imagery we were able to capture and shared these with the participating students. Many of the most popular were taken from only a few dozen feet above the ground, but showed the students and their immediate environment from a new perspective.

However, while we awaited a major success in capturing imagery (a success which took 14 days to achieve), the students were engaged in other projects. Beyond discussing and drawing maps of Juan Pablo II, students interviewed their parents and presented drawings and short reports on the history of the settlement. This resulted in some cases in very detailed accounts of how homes began as straw ‘caracoles’ or tents, and progressed to wooden, metal, and even brick structures.



One student named Frank recounted what year his family received electricity and when they began planting a garden. While these details may be exciting to hear from a historical, anthropological, or aid perspective (I had received specific requests from a cartographer from the World Bank for details on house construction), for myself and my fellow teachers, it served the more important role of contextualizing the current state of the settlement — for the students — in a years-long process of construction and reinvention. It also emphasized the time dimension of mapping, so often neglected, which in areas of such rapid change can render mapping efforts obsolete within just a few years. Indeed, the maps we were beginning to produce from aerial imagery showed that those available on Google Maps were so old as to omit entire roads and buildings.

We then asked students to produce similar work — drawings and written reports — on how they imagined the community might look in the future. We asked in this case for a depiction of the entire settlement, and were surprised when two students brought back a three dimensional model of Juan Pablo II, as it might appear seven years in the future. While the early aerial images and mapping exercises had prompted many students to depict their community in a bird's-eye view, this maquette revealed many details related to wealth and quality of life, and an awareness of family needs. Unlike in present-day Juan Pablo II, the model depicted many two or three-story buildings — signs of long-term tenure and financial stability, and perhaps rental income. The buildings were largely depicted as brick, and many had stores, such as a hair salon or a flower shop, on their ground floors. An especially interesting feature was a 'Wa wa wasi', or day care center, which does not exist in present-day Juan Pablo II, but which allows two parents to work longer hours while their youngest children are cared for. Paved roads, plantings, and a soccer field completed this ambitious plan for the settlement.

This kind of mapmaking recalls the 3D Model Mapping or Ground Mapping traditions of PGIS practice, with an emphasis on community assets and the explicit link between mapping and urban planning. The ability to view the model both from above as we were doing with balloons in the **real** Juan Pablo II, as well as from a first-person perspective by planting one's head amongst the buildings, bridged the gap between the abstracted god's-eye view and the situated personal view of the settlement. The model was extremely popular amongst not only the rest of the students and teachers, but amongst the parents and community leaders who attended our final presentation.

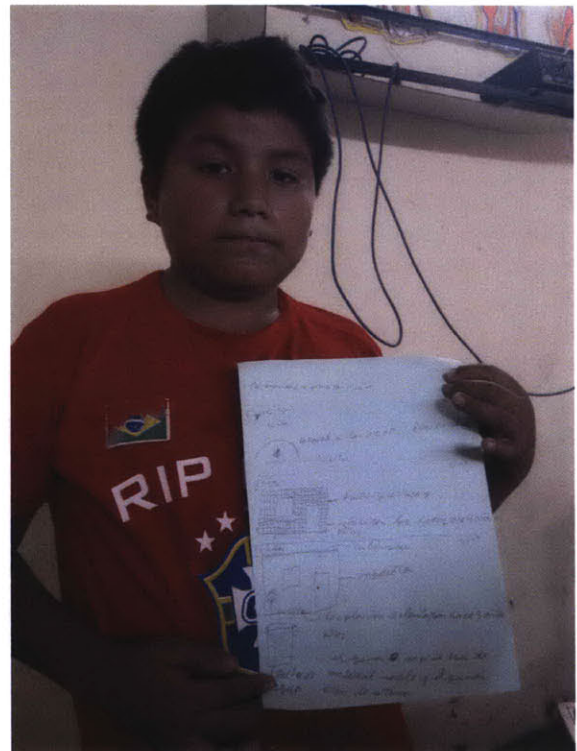

**Figure 7.5:** Frank, a student from Juan Pablo II, presents a detailed history of infrastructural improvements to his home.





**Figure 7.6:** 3D paper model of the future of Juan Pablo II.

### **Stitching maps with Juan Pablo II**

Throughout the balloon and kite flights, we employed various techniques to process the aerial imagery into maps. Starting with the Map Warper software available at <http://warper.geothings.net> with teachers from Manzanita ‘A’, we switched to Adobe Photoshop after a few attempts. Designed for printed maps, Warper experienced difficulty successfully warping some of the more oblique or distorted imagery, and in order to compensate, GCPs had to be placed at deliberately incorrect position in a laborious trial-and-error process. (See Subsection 6.1.4 for an overview of Map Warper). Additionally, Warper uses OpenStreetMap tiles as a base layer, but in Juan Pablo II and other areas we worked in around Lima, there was no data available, and we were forced to use a JavaScript hack to insert Google satellite imagery or another viable source. Even then, it proved difficult to successfully stitch a map, as multiple steps separated an assignment of GCPs with the feedback that an image was successfully warped. This is not to say that Map Warper is not a valued tool for its intended use, and in fact Shekhar Krishnan more recently applied it successfully in digitizing paper maps of Mumbai. However it was not suitable for much of the aerial imagery we gathered, and proved difficult for those with limited computer fluency.



Our next tool was Adobe Photoshop CS4, which can yield impressive results for an experienced user (see GonzoEarth, Subsection 5.3.2). This proved to be a workable alternative, where we used the Distort and Warp tools to align images in separate layers over a base image taken from Google Maps or another source. The total process for stitching 12-15 images took approximately 2-3 hours. Though not a GIS tool, Photoshop has the benefit of being fairly easy to obtain, though in fact none of the teachers I worked with had a copy. Still, the use a generalized tool has the benefit of encouraging the learning of generalizable skills, and can result in a more inclusive process. PGIS researcher Peter Poole notes in his own projects that in order to build a mapmaking capacity in areas of low computer literacy, ‘tracing was chosen over digitisation, and simple graphics software over geographic information systems (GIS).’ [63]

Most of these tools were inaccessible to the students we worked with, who were largely without computer access, however in order to help them understand the process we organized an activity to try fitting printed images together in a kind of puzzle, suggesting that they imagine the images were printed ‘on rubber sheets’. This was so readily understood by all that it inspired the choice of a ‘rubbersheeting’ interface paradigm for the Cartagen Knitter software I developed after the Lima project concluded. (See Section 6.2.3)

### 7.3 Mapping with San Ignacio Loyola

With Carla del Carpio, I began working with a second community called San Ignacio Loyola, approximately 1 mile southeast of Juan Pablo II. Our local partner was a teacher named Hector, who had a class of very young students, aged 5-10. Though we had limited success in mapping exercises with the class, Hector proved to be an ideal collaborator, and actively sought to internalize the skills needed to produce balloon maps, with the intention of teaching the techniques to older students in the fall. While members of San Ignacio Loyola already have both title to their land and a completed survey of their lots, Hector saw the applicability of low-cost aerial mapping to informal settlements, and showed a lot of enthusiasm and energy in organizing flights with us



Figure 7.7: Demonstration of JavaScript hack to insert Google satellite data for warping in areas with low feature density. [82]

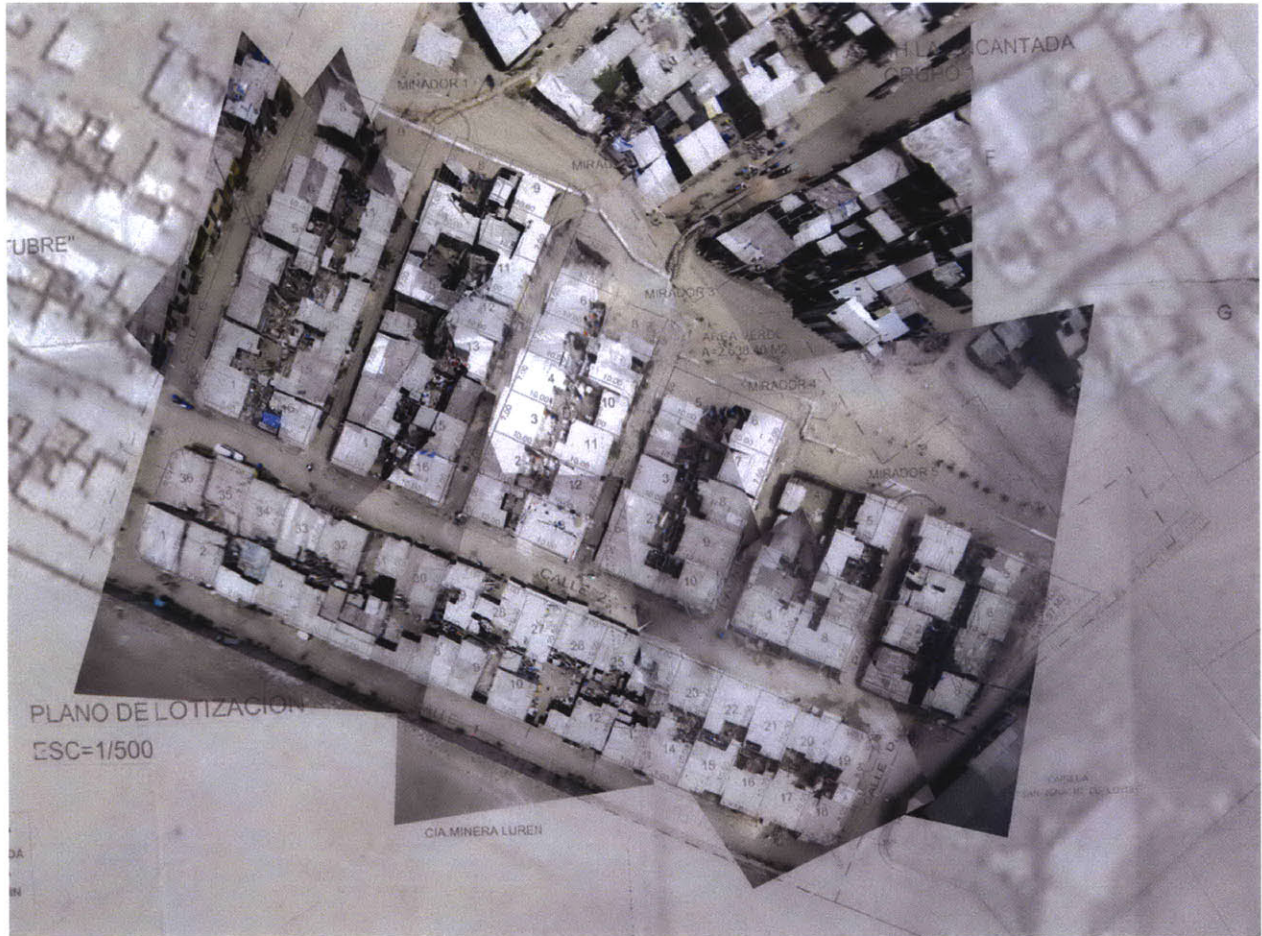

Figure 7.8: Students collaborate in a semi-imaginary ‘rubber sheeting’ map stitching session.



despite his heavy workload as both a teacher and a community leader.

Hector experienced similar if more pronounced difficulty in using Photoshop to stitch maps, but the imagery we captured with him over two 3-hour flights was superior to that of our Juan Pablo II flights. This may have been due to more favorable local wind conditions or our greater experience, but the result was a highly detailed and largely complete aerial map of the San Ignacio Loyola settlement. It became clear to us that building alliances and friendships with interested and energetic local partners was key to successful mapping.



**Figure 7.9:** A balloon and kite map of San Ignacio Loyola, produced with Prof. Hector and Carla del Carpio. The map is overlaid on the existing Google Maps imagery for comparison, and also includes the surveyed lots of which Hector had a printed copy.

## 7.4 Mapping with Cantagallo

It soon seemed as if ‘word was getting out’ about our mapping efforts, as we were soon invited by Lima-based art, technology, and society foundation Escuelab, to collaborate on a mapping project with their partners in a central Lima community called Canta Gallo. Escuelab’s work, led by Barcelona artist Daniel Miracle, consisted of a series of workshops with a Canta Gallo art collective



known as Shuawa<sup>2</sup>. Canta Gallo is a community of Amazonian Shipibo who have invaded a plot of land along the bank of the Rimac river; a breathtaking site in the center of metropolitan Lima. Made up of several distinct groups, the settlement includes Shipibo and mixed heritage members who did not move to the site together, but have slowly migrated from around Lima. They have spent the last 10 years seeking legal title to the land, and different factions are at different stages in the process.

The group we began working with was situated on a large hill of rubble — a landfill which leaked methane and around which residents had strewn concrete blocks to stop further dumping. Despite their difficult situation, the settlement seemed cheerful and was brightly painted with murals. An electric guitar and keyboard played in a local hangout, while posters on the communal meeting house indicated each family's dues toward land registration fees.

In the midst of this, Escuelab had sought to establish a neutral space by working with local artists to develop a series of arts workshops and activities for the children of Canta Gallo. Based in a state-funded school in the settlement, Daniel Miracle and others collaborated with residents such as Layner Mori to lead students in the production of digital films, animations, and incredibly, a live broadcasting news show (in the Shipibo language, no less) using a low-cost analog television transmitter. Escuelab's interests tended towards the political, as evidenced by their engagement in Shipibo/Spanish language issues amongst their students<sup>3</sup>, as well as their close attention and sensitivity to the complex tenure situation and other sources of tension in the community. However, their preference for an implicit treatment of these topics and their exploration through educational and artistic works was well matched with my own approach.

On my first day in Canta Gallo, we repeated some of the exercises I had used in Juan Pablo II, though in a shorter format. With help from Layner, we drew a large map of the settlement in rough outlines, and asked the students to draw their homes and place them on the map. The group, aged 6-12 and approximately 20 in number, produced a quantity of highly detailed drawings, though some students drew two or even three copies of their houses. One student drew one picture of his home in Canta Gallo and a second of his home in 'la selva' — presumably the home in the Amazonian region of Peru from which he had moved to Lima. While the non-literal nature of this

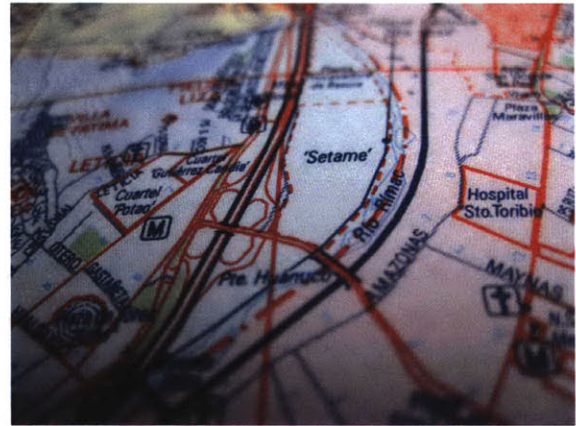

**Figure 7.10:** The standard street map of Lima shows only a vacant lot owned by the city's roads administration, SETAME. The reality is a community of hundreds of people who have sought legal title for the last 10 years.

<sup>2</sup>An interesting choice of names given that Shuawa is the name of the bird from Shipibo legend which links 'maestros' in a kind of global communications network. Members of Escuelab referred to it as the 'satellite bird'.

<sup>3</sup>The desire of some families to preserve the Shipibo language and others to raise their children with only the Castilian Spanish language was one facet of a larger ethnic division between full-blooded Shipibo and mixed-heritage members of the community. See also Zavala and Bariola's study of Cantagallo in 'Enra kopiai, non kopiai: Gender, ethnicity, and language use in a Shipibo community in Lima'. [87]



kind of mapping presents challenges for data veracity, it is clear that children can produce a wealth of physical, historical, and culturally relevant detail, and I caution map-makers not to sacrifice this in favor of purely quantifiable information.

### **Flying balloons with Cantagallo**

After our sketching activities, we attempted to fly kites, as there was a light breeze. While the students were very assiduous and talented kite flyers, we eventually opted for a balloon flight, which resulted in a complete imaging of the settlement in less than two hours, from about 400 feet. To attempt a faster and more automated stitching technique, I used the open source program **hugin** and the **Autopano-SIFT** algorithm to stitch the images together, and overlaid the result on existing Google Maps imagery as well as a copy of the settlement boundaries supplied by one of the community leaders. This was our fastest time yet for the completion of a map, and was the first map — of any kind — of the settlement.



**Figure 7.11:** Paper mapmaking activities with children in Canta Gallo, Lima

### **The rest of Canta Gallo and local geographic dispute**

Following the completion of the initial map of Canta Gallo, Sara Gomez of **CEDRO** suggested that we attempt to map the adjacent settlement, which I was surprised to find was also part of Canta Gallo. Collaborating again with Daniel Miracle and Escuelab, we met with Sr. Ricardo, the leader of the lower part of Canta Gallo and spent a day mapping that area as well. I worked with Layner Mori using Photoshop to stitch the resulting imagery over a map supplied by Sr. Ricardo, and we printed a paper copy. In a discussion with Sara, Layner, and Daniel, we decided to combine the two maps — which showed some overlap — and distribute the combined map.

Producing a combined map was a potentially controversial decision, as the two settlements were experiencing some tension due to both ethnic and territorial issues. The lower settlement, spread over a much flatter and larger area, was presumably further advanced in its bid for land title, as they had a surveyed map with well-defined lots, whereas the upper settlement with whom we had first worked had only a map of its outer boundaries. However, in an attempt to avoid involving ourselves in local political issues, we deemed it more fair to provide maps and mapping tools to both communities equally. In retrospect, I feel that to attempt to position ourselves as neutral parties may have been misguided, as producing maps and teaching mapmaking workshops are by no means a neutral acts. However, I do believe that providing open access to these tools and techniques, as well as to the geographic information they can produce, is a constructive goal. One aspect of maps which I value highly is their ability to reconcile differing mental models of a geography, and to make





**Figure 7.12:** A balloon map of Canta Gallo, produced with Shuawa, Escuelab, and Carla del Carpio. The map is overlaid on the existing Google Maps imagery for comparison, and also includes the settlement boundaries, taken from a printed copy contributed by community leaders.

explicit the differences between those models. My hope is that we helped to do so in an inclusive manner.

## 7.5 Evaluation

Any comprehensive evaluation of the mapmaking work I and my local partners performed would need to include a long-term examination of the maps' uses; legal, urban planning, educational, and political applications were among our hopes, but many of these processes occur on a timeline of years or even decades. Still, in the half year since their creation, the maps of Canta Gallo have been used for subsequent projects by Shuawa, and Helder Solari, one of the activists involved in the original mapmaking, asserts that 'in fact even now there is none better than yours. In other maps Canta Gallo simply doesn't exist.' While I look forward to hearing of as well as advocating further uses of these maps, the immediate evaluation I can attempt will have to rely upon the maps' reception among participating community members and in the qualitative and quantitative measures which can be made today.

On a resolution basis, these maps are far superior to any which have been made before (see Figure 7.1). However their most important quantitative advantage is their recency; in comparison, those available on Google Maps are hopelessly obsolete, sometimes showing only a small percentage of





**Figure 7.13:** A balloon kite map of all of Canta Gallo, produced with Shuawa, Escuelab, Sara Gomez, Carla del Carpio, and residents of Canta Gallo. The map is overlaid on the existing Google Maps imagery for comparison, and also includes printed maps contributed by community leaders. Note that a small area is missing; unfortunately the balloons popped near the end of the day and we lacked enough helium to continue.

the buildings which exist today. Due to these impressive numbers, a variety of individuals and organizations have suggested uses for the data, ranging from tracing and import into OpenStreetMap to use in World Bank needs assessment or municipal datasets. While I think these are generally good ideas, I also believe that the decision to publish any map data is one which community leaders and those involved in the creation of the data should make. My own publication of these maps for educational and research use was only after explicit permission was granted by all involved parties.

Finally, and far more importantly than the technical evaluation, I was careful to record the reception and discussion of this project amongst its participants, and especially amongst the residents of the areas we mapped.<sup>4</sup> This took the form of informal interviews with partner organizations and residents, as well as my notes and observations, but due to the speculative nature of the project, it followed no specific plan, and was by no means an attempt to develop a formal scientific or ethnographic study. Rather, I used the information to develop a more comprehensive and measured approach in subsequent case studies, and to identify shortcomings in the mapping process.

### 7.5.1 Needs (Re)assessment

The Lima project demonstrated the feasibility of participatory mapmaking projects with low cost tools such as balloons and kites. However, it also highlighted the need for a simplification of available tools and for new, easier interfaces, especially for the digital post-processing steps, in order

<sup>4</sup>For a more thorough discussion of my evaluation strategy, see Section 9.1.



**Table 7.1:** Comparison of maps produced in January 2010 project in Lima, Peru with those available in Google Maps for the same period.

Site	Criteria	Grassroots Mapping	Google Maps	Percent change
<b>Juan Pablo II</b>	Resolution	4.4cm	29cm	+659
	Recency	new	2-3 yrs old	
<b>San Ignacio Loyola</b>	Resolution	3.4cm	29cm	+853
	Recency	new	2-3 yrs old	
	Roof count			
<b>Canta Gallo</b>	Resolution	7cm	29cm	+411%
	Recency	new	2-3 yrs old	

to increase inclusion and avoid dependency on outside assistance. Specifically, the orthorectification and publication tools we tested were inadequate. The feedback and brainstorming we conducted with various collaborators led me to begin work on a new tool which eventually became the Cartagen Knitter discussed in Section 6.2.2. This tool would need to be easy to install or run in any internet cafe (I opted to a web-based tool). It would need to make use of an intuitive mental model for orthorectification; rubbersheeting, as explored with students from Juan Pablo II, was a good fit. It would need to export maps in a format which could be easily printed, and finally, it would need to be tested in the field with a diverse group of users.

The difficulties we experienced in flying balloons and kites in Juan Pablo II underlined the importance of good equipment, timing, and a good understanding of local weather conditions. Still, the exceptional maps we were able to produce at every site were encouraging, and the speed with which we were able to map a given site suggested that repeated periodic mapping, or mapping much larger areas, could be possible.

Above all, I learned the importance of building capacity amongst local partners, and the need to address the pedagogical challenges of this kind of participatory mapmaking. My experiences teaching others to use these tools, and working with them to adopt, internalize, and improve the necessary skills to create maps, highlighted the need for better teaching materials, guides, and a more structured approach to skills transfer. These would be major themes in the following case study in the Gulf of Mexico, where many of the lessons learned in Lima were put to the test.



**Figure 7.14:** Comparison of scales and level of detail between Grassroots Mapping imagery and existing Google Maps/GeoEye imagery at San Ignacio Loyola.

## Chapter 8

# Case Study: Citizen mapping of the BP oil spill

### 8.1 Grassroots mapping in crisis response

In late April 2010, the Deepwater Horizon oil rig exploded and sank, initiating what may be one of the worst environmental disasters in US history. [70] As the spill grew in size, I contacted Stewart Long of GonzoEarth.org and Oliver Yeh of 1337arts.com, both of whom I had collaborated with in recent aerial mapping projects.

Long has made use of remote control aircraft to capture map imagery, and Yeh specializes in high-altitude photography using weather balloons, having captured imagery from a balloon at altitudes of over 90,000 feet. We decided to travel to the Gulf Coast area to spearhead a citizen effort to map the oil spill's effects. After making phone contact with Anne Rolfe of LABB, a New Orleans-based environmental activist group, Yeh and I flew to New Orleans on May 5th 2010, followed by Long on May 6th.

With the cooperation and extensive support of LABB and other interested New Orleans residents, we began leading almost daily trips to use balloons and kites to map coastal areas. While not attempting to produce imagery of the entire coastline, which stretches several thousand miles from Louisiana to Florida, the mappers focused on acquiring high resolution imagery of specific sites, with the goal of producing 'before and after' maps. The trips relied on the availability of free transport to affected areas, but in the initial days of the project this was not a problem, as fishermen and charter companies began calling in to offer rides at no charge. Increasingly large areas of the Gulf of Mexico were



**Figure 8.1:** Volunteers at the Louisiana Bucket Brigade in New Orleans plan a mapping trip on May 7, 2010.



being closed to fishing, and with their livelihoods at risk, many in the fishing industry were eager to participate in the documentation of the spill. [54]

## 8.2 Comparing Grassroots Maps of the spill to other sources

Beyond the importance of establishing an independent monitoring effort of the oil spill's effects, the disaster was an opportunity to apply the low-cost mapping techniques refined and documented on GrassrootsMapping.org to a problem of immediate import, and on a large scale. While many overflights were occurring, there was no publicly available, orthorectified imagery available in the initial weeks of the spill; up-to-date imagery was supplied mainly by the Moderate Resolution Imaging Spectroradiometer (MODIS) sensors aboard NASA's Terra and Aqua satellites.<sup>1</sup> MODIS is limited to 250 meter resolution, and while the daily images available were very useful in determining where along the coast was being hit by slicks and sheens, they were not of high enough detail to show any specific damage. [40]<sup>2</sup>

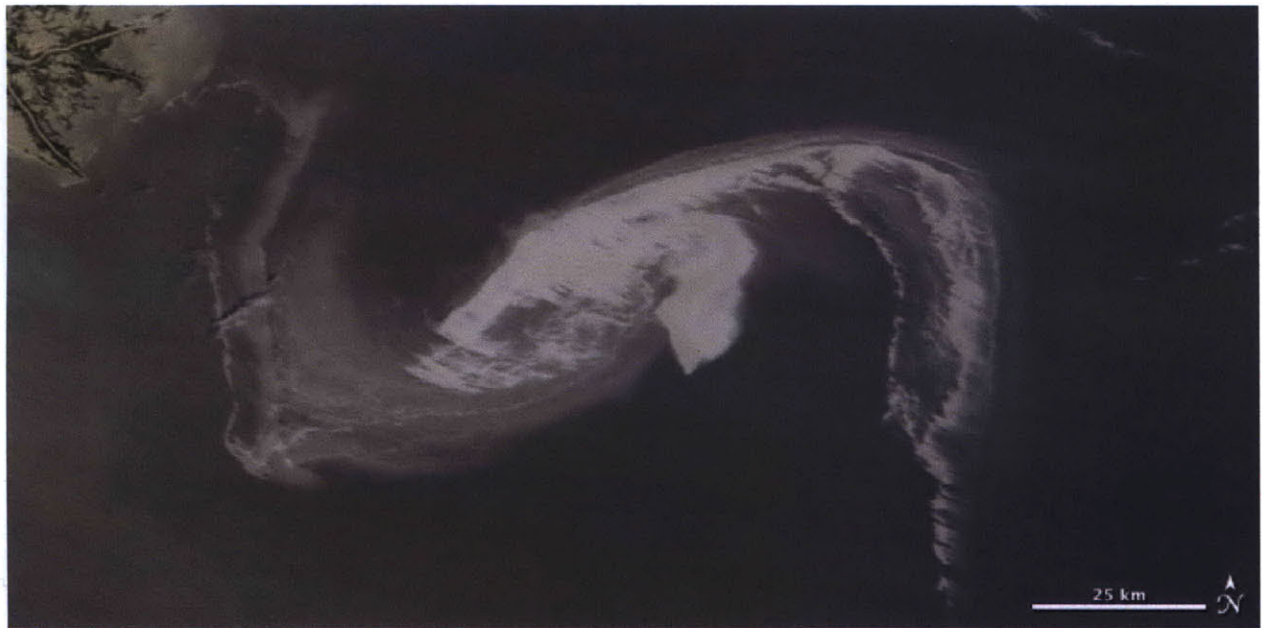

**Figure 8.2:** The BP oil spill on April 29th, 2010. The upper left corner shows the tip of Louisiana. Imagery from NASA's Terra satellite, using the MODIS sensor.

By contrast, the imagery collected by the LABB/Grassroots Mapping teams was up to 3cm nominal resolution, and could be repeatedly captured over the course of days or weeks. This level of high resolution imagery, as James Aber et al. point out, 'bridges the scale and resolution gap between ground-based observations of wetlands and conventional airphotos and satellite images' [1], and both balloons and kites have previously been explored as feasible platforms for wetlands monitoring.

<sup>1</sup>Since then, overflights by National Oceanic and Atmospheric Administration (NOAA) have appeared in the 'historical imagery' section of Google Earth. These cover a great deal of affected coastline but are of relatively poor resolution compared to LABB/Grassroots Mapping imagery.

<sup>2</sup>For more information on the MODIS sensor and its abilities, see <http://modis.gsfc.nasa.gov/about/specifications.php>

[1][51] Michiro Miyamoto in particular has used balloon imagery of 15cm resolution to classify vegetation types 'to the genus and species level'. [51] In LABB/Grassroots Mapping imagery, even individual bird species were identifiable, and coral, oil smears, and schools of fish are visible in many photos. In addition, the unfolding nature of the oil spill crisis made it important to visit and map sites both before and after oil was sighted, and periodically afterwards. The potential for a set of maps of the same site, taken at intervals, to depict progressive damage to ecosystems and economies was a powerful new dimension to the project.

### 8.3 Independent monitoring and media blackout

As the crisis progressed, it became clear that BP was attempting to restrict access to affected areas by means of airspace restrictions, closing public beaches, and preventing boats from entering some areas. The Breton Sound was closed to the public in mid May, and flyovers were restricted to a minimum of 4,000 feet, making it difficult to photograph or identify features on the ground. [62] With reduced public and media access, many became concerned that because of the close collaboration between BP, the Coast Guard, and NOAA, the government was complicit in the media blackout. Even on the ground, LABB mappers found that many cleanup workers were prohibited from talking about what they were doing. [25] This gave our mapping effort even greater importance, as our imagery was among the best available for many areas, and the support we received from local fishermen in getting to sites helped us to sidestep issues of access which limited many in the mainstream press.



**Figure 8.3:** Streaks of oil, terns, and, in the lower left, pelicans, on a sandbar in the southern Chandeleur islands, Louisiana coast, on May 9, 2010.

### 8.4 Adoption and sustainability

The most challenging aspect of organizing the oil mapping project was to train a group of inexperienced but committed volunteers to use Grassroots Mapping tools such as balloons and kites, in often adverse weather conditions up to 3 hours travel from our home base in New Orleans. That a number of volunteers have continued not only to make trips on their own, but to bring and train others to map, has been both impressive and gratifying.

Between May 7th and July 22nd, over 47 participants made 36 trips to gather mapping data, or almost one every other day. While only one trip has failed to return with any imagery at all, 64% of trips returned with 'excellent' or 'useable' data, suggesting that better quality control mechanisms might result in a higher success rate. Still, over 11,000 images have been taken, with plans and





**Figure 8.4:** A map of Isle Grand Terre, Louisiana on May 27 2010, stitched by Stewart Long





**Figure 8.5:** A map of the southern Chandeaur Islands on May 9 2010

funding in place to continue mapping through January 2011.

### 8.4.1 Workshops and trainings

One factor that likely played a major role in the rapid adoption of Grassroots Mapping techniques was the early emphasis on training. With LABB, we organized a workshop in the first week of mapping for potential volunteers in New Orleans, where we demonstrated the use of the tools in a hands-on manner, flying kites and capturing a sample data set. In addition, trips to mapping sites have continued to attract new volunteers, and the teaching of aerial mapping techniques to newcomers has been a priority throughout the project. We have been lucky that LABB has combined their outreach programming with aerial mapping trips, resulting in a steady flow of new mappers.

Participation has followed several interesting trends. As shown in Figure 8.4.2, while over 30 people participated in a single mapping trip, far fewer were part of a second or third trip. However, a committed group of leaders have been participants in six or seven trips; these have ensured a continuous and regular mapping effort across the initial fifteen weeks of the project.

Particularly encouraging was the participation of two mappers who had seen just a single presentation about the project, and were inspired to begin balloon mapping on their own. Assembling their own kit based on information available on the Grassroots Mapping website, Don and Justin Blancher contacted us with hundreds of photos of Perdido Point, Alabama. Delighted, we arranged a transfer of files and Stewart Long created a map within a few days. As of August 2010, the two continue to contribute new data.

### 8.4.2 Collaborations

From the start of the project, the Grassroots Mapping mailing list and wiki were a focal point

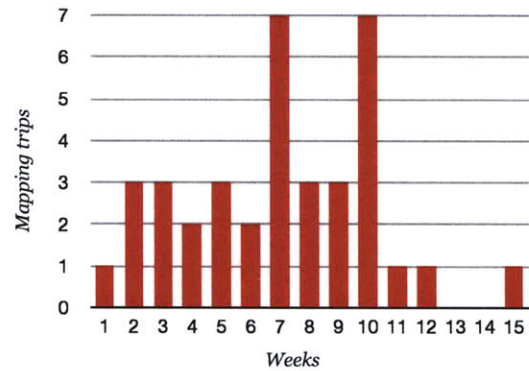

**Figure 8.6:** Number of mapping trips per week. A drop in trips starting in week 11 was due to high summer heat and the absence of several of the project’s main trip leaders who were on vacation.

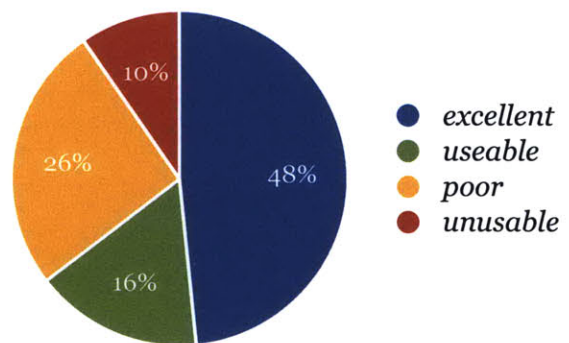
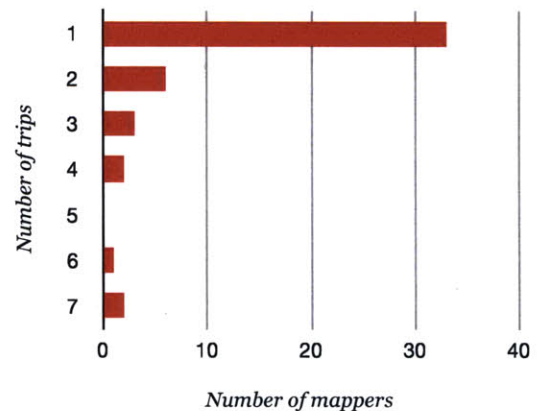

**Figure 8.7:** Success of mapping trips, based on number of images captured



for collaboration, and members of the wider Grassroots Mapping community helped identify local helium sources, coordinate volunteers, and even pay for plane tickets. On the ground, there was also considerable ad-hoc collaboration, with Oliver Yeh of 1337arts and Stewart Long of GonzoEarth leading trips and trainings on multiple occasions. However, over the first several weeks, Shannon Dosemagen of LABB, and Kris Ansin of the University of Tulane’s School of Public Health and Tropical Medicine emerged as leaders of local mapping trips, and their efforts have ensured that mapmaking has continued for close to three months since our initial efforts. Long and I have played a supporting technical role in managing, processing, and publishing stitched maps of the data, and advising the LABB team on equipment setup and maintenance.

Throughout the project, we made partnerships with a variety of other organizations to share boat trips, imagery, and to collaborate directly on capturing imagery — among these were the Blue Seals, Greenpeace, Americorps, and many individuals who volunteered their time, money and abilities. This dense web of collaborations has formed a backbone of support for the effort, and ensured its regularity and sustainability. While the urgency of the disaster itself surely played a role in forging such a network of mutual support, such strong local participation must be an integral part of **any** participatory mapping effort which expects to be sustained beyond an initial burst of enthusiasm.



**Figure 8.8:** Number of mapping trips per mapper

### 8.4.3 Costs and funding model

Mapping the spill incurred a range of new costs; not only is there a virtually unlimited potential area to map, but the intention to repeatedly map each site meant that there is no obvious completion criterion for the effort — trips are led and imagery is captured as often as possible given the constraints of time and money. While the costs of equipment were still in the range of \$150-200 per kit, travel turned out to be the most expensive part of the project. Not counting the hours of donated time and associated fuel costs on boats, planes, and in cars, a typical day in a chartered boat cost approximately \$400, and even teams visiting only the shoreline had to travel for upwards of 3 hours each way from LABB headquarters in New Orleans.

Various donors and institutions were generous in their support of the project, including the Center for Future Civic Media, the Lafourche Port Commission, the Washington Post, Development Seed, and many more.<sup>3</sup> In order to meet ongoing expenses, on May 29th I created a proposal at [Kickstarter.com](http://Kickstarter.com) with help from filmmaker Kristian Hansen. Kickstarter is a site where individuals can elect to ‘back’ a project financially, receiving rewards for different levels of support. For \$50, we offered to put backers’ names on a balloon; for \$1000, we promised to send backers a complete Grassroots Mapping Kit. However, the vast majority of donations are at the \$25 level, and a total

<sup>3</sup>For a full list of contributors please see the Acknowledgements



of 145 contributors backed the project with \$8,285 by June 21, 2010.

Funding the project in this manner rather than via larger institutional grants seemed appropriate for an already citizen-led, independent effort to document the oil spill's effects. For many, contributing a small amount or even simply spreading the word was the only means of participating. For these reasons the choice of Kickstarter as a means to financial sustainability is especially appropriate to the project's mission.

## 8.5 Image processing and map stitching

Throughout the project in the Gulf of Mexico we have relied heavily on Adobe Photoshop for manual orthorectification of maps, due to its proven track record and known limitations. Other tools such as Map Warper and Cartagen Knitter were limited by their dependence on OpenStreetMap base data, though Cartagen Knitter has since gained the ability to display a base layer of tiled satellite imagery, and may see increased usage for future map data sets. Photoshop produced Tiled Image File Format (TIFF) images which were processed into GeoTIFF and cut into tiles using the `gdal2tiles.py` script. This generated both a TMS and a KML for viewing online. Maps were also uploaded to Flickr for public viewing, though at a lower resolution, since Flickr limits uploaded files to 10 megabytes in size. In addition, the most permissive license provided by Flickr was Creative Commons Attribution, so maps were annotated as Public Domain data in each image's description field.

Those in the project who were able to produce stitched maps, including myself and Stewart Long with some help from David Riallant and Cesar Harada, were challenged to keep up with the fast pace of map data submission. New data sets arrived as often as every other day, and a single set typically included hundreds of images to be sorted, processed for brightness and contrast, and stitched. A large monitor and a powerful computer were required, and even my own 8-core 3 GHz workstation took up to 10 minutes for each transform on larger maps. These issues, as well as the difficulty in including a broader group in the stitching effort, highlighted the need for a completed Cartagen Knitter tool, even as it took time away from its development.

One tool I developed in response to this overwhelming amount of data was called MapMill, avail-

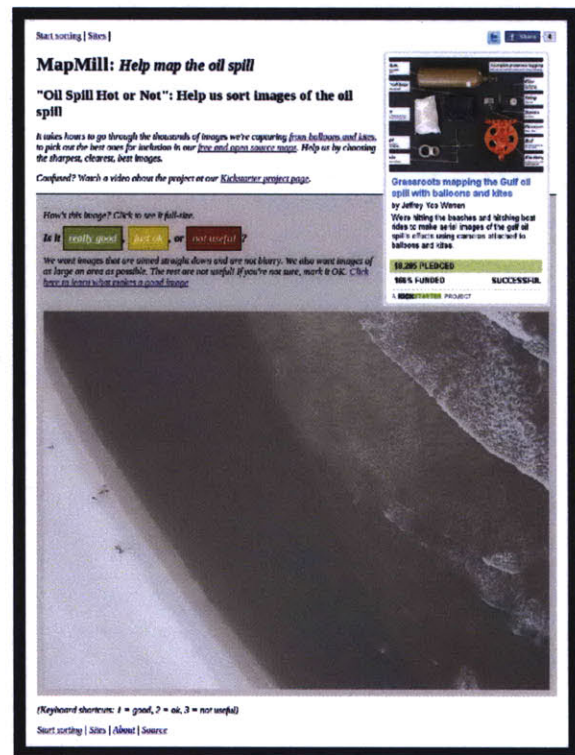
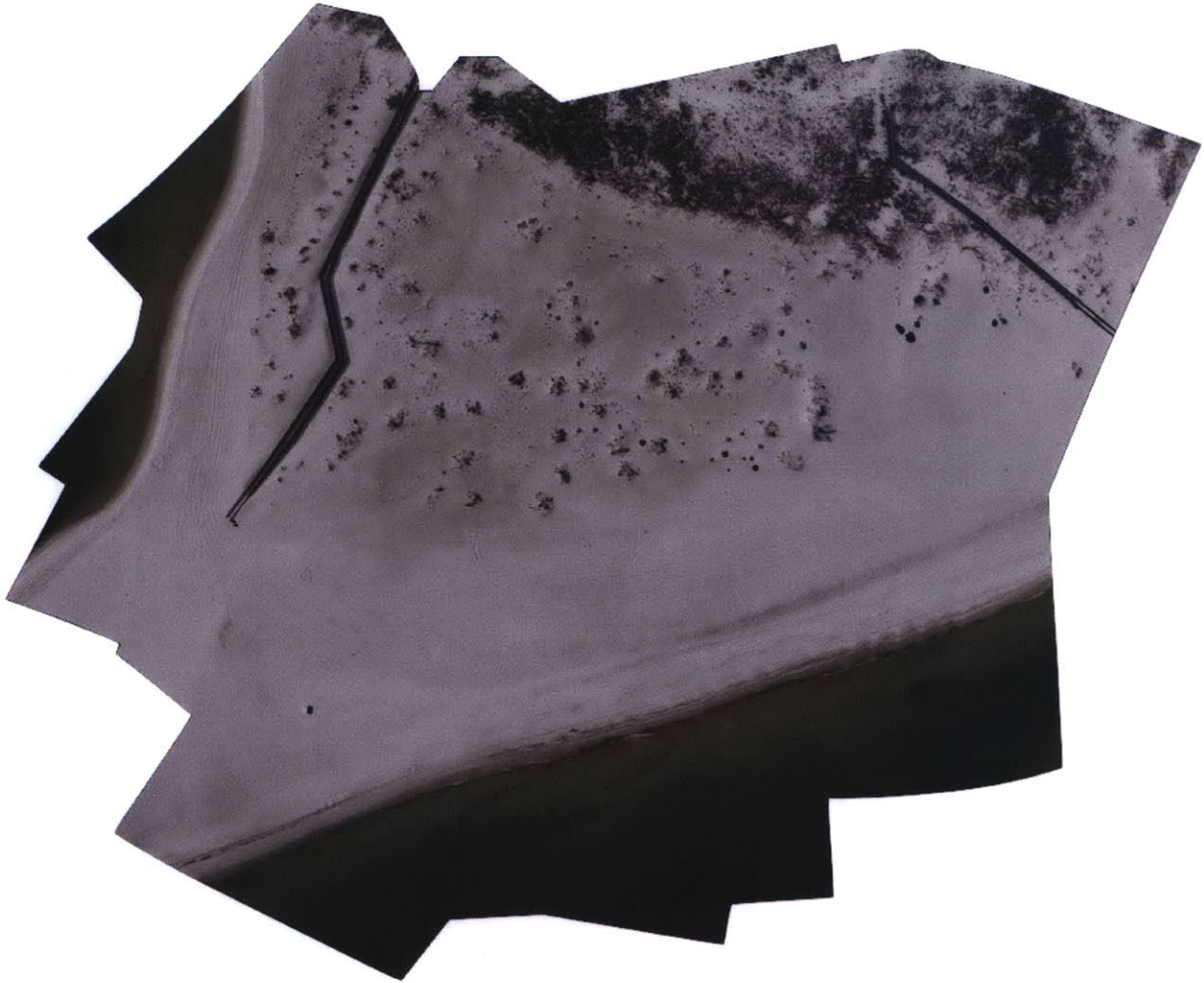

Figure 8.9: MapMill.org image sorting website developed in response to the high-volume data submission from the Gulf of Mexico during the BP oil spill.



**Figure 8.10:** A map of Perdido Point, Alabama, from imagery captured by Justin and Don Blancher and stitched by Stewart Long.



able at [mapmill.org](http://mapmill.org). As sorting through images often took a substantial amount of time before orthorectification or stitching could begin, visitors of MapMill were presented with an aerial image, and asked to rank it as ‘really good’, ‘just ok’ or ‘not useful’ in an adaptation of the interface to the well-known ‘HotOrNot’ website. A one-page visual guide was offered to demonstrate what constitutes a ‘good’ image, highlighting crispness, good exposure and downward-facing camera angle. In the 50 days following its launch on June 16th, 2010, images have been ranked more than 23,000 times, demonstrating that a voluntarily crowdsourced means of image processing may be viable.

## 8.6 Overflights and a broader data strategy

As more organizations such as the Blue Seals and the Louisiana Environmental Action Network became involved, opportunities arose for the capture of data from donated airplane flights. While this was outside the scope of the Grassroots Mapping Kit, we took every opportunity to gather such data, and several of the datasets we have published were captured by volunteers on such flights, or were donated and released into the public domain. This has helped bridge the gap in scale, methodology, and image quality between our balloon and kite derived imagery and more conventional techniques, and in retrospect may help those in crisis management situate our work in a larger data gathering strategy.

## 8.7 Integration with Ushahidi

The LABB team had already set up an instance of the Ushahidi mobile-phone based crisis reporting tool for crowdsourced information gathering, and this continues to be one of their main priorities and most publicly visible responses to the spill. To better integrate our aerial mapping data with the Ushahidi platform, I inserted TMS layers of our data into the OpenLayers-based Ushahidi map display, so that report locations would appear overlaid on aerial imagery where available. This generated a feedback loop for mappers, who would often look to Ushahidi to identify clusters of oil sightings which made good candidate sites for aerial mapping.

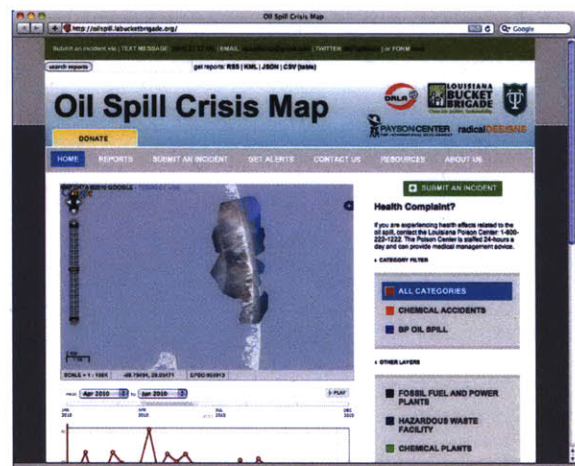
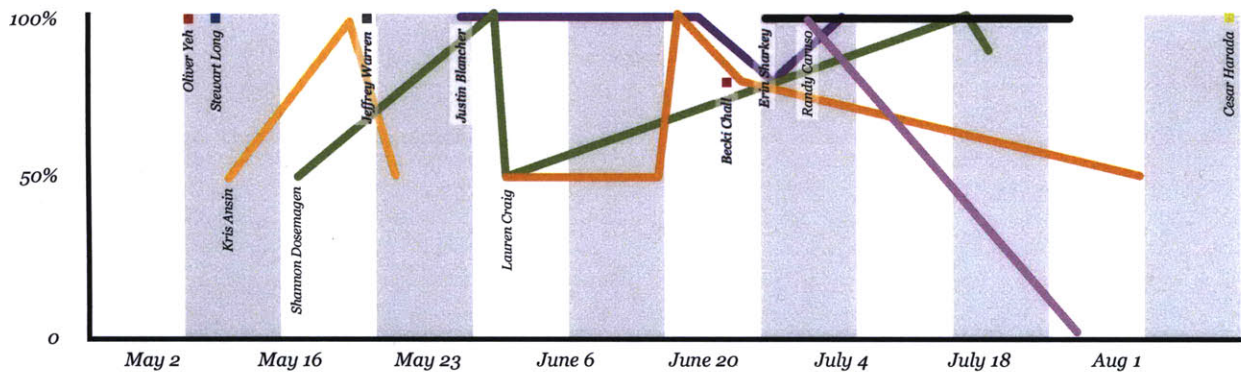

**Figure 8.11:** Data collected and processed by the Grassroots Mapping team, displayed as tiles in the LABB Ushahidi instance.



## 8.8 Documentation

The disaster and the incredible support and diligence of the LABB mapping team also generated a wealth of both qualitative and quantitative information on the volunteer-led effort to apply Grassroots Mapping tools toward the collection of crisis information. Mapping team leaders filled out a form describing a variety of information from weather conditions at the site to the condition and performance of the gear. Leaders built deep experience in gathering data and teaching others, and many wrote blog entries or spoke to the press about their experiences. Beyond serving as a valuable independent record of the spill, this case study lays solid groundwork for the application of these tools to other environmental, social, and political crises. A similar online form for data submission should be an integral part of any future aerial mapping effort.



**Figure 8.12:** Success of mapping trips over first 100 days, based on evaluation of resulting imagery by GonzoEarth

### 8.8.1 Analysis of data collected

New imagery continues to arrive from mapping trips across the Gulf Coast, but the data we have so far is useful for examining what factors affect the success rate of mapping attempts, as well as for assessing the increase in data quality as participants gain experience and the techniques mature. Of course, it is also of interest to quantify our results to date in terms of resolution, extent, and fidelity.

Trip results were rated on a percentage scale as imagery was reviewed, based on the image sharpness, continuity, and angle of capture, straight downwards being ideal. The average rating over the first 33 trips was 75%; while I expected a correlation between experience mapping and success rate, as seen in Figure 8.8, no such relationship is apparent. Participants did use both kites and balloons regularly, with 45% of trips using kites and 55% balloons. Based on reported and best-guess estimates of altitude, 14 trips which used balloons reported an average altitude of 725 ft and 10 trips using kites reported an average altitude of 670 ft. Most participants preferred balloons, citing easier control given reasonable wind conditions. In general, difficulty with the tools was less of an obstacle to success than adverse weather conditions. (See Figure 8.1)

One challenge was to maintain good communication between those processing imagery and stitching maps, and those visiting sites and capturing images. The former were typically working remotely,



and beyond the data submission form we asked each trip leader to complete, there was relatively poor communication between the two parties. This led to delays when map stitchers were unable to identify where images were taken, or difficulties when trip leaders did not understand the stitching process well enough to know what constitutes good source imagery. The use of the Cartagen Knitter in this process may address these problems by making the orthorectification and stitching process more intuitive and accessible to those who capture imagery. Reducing dependence on outside technical assistance promises not only to put local participants in greater control of the entire process, but to improve overall understanding of the stitching process and thus yield better source aerial imagery from mapping trips. In any case, future efforts should facilitate open communication between participants at different stages of the process to ensure good results.

## 8.9 Licensing and data use

The assembly of a public domain archive of data on the disaster, including GeoTIFFs, TMS and raw images, is a valuable goal in itself. Due to increased mapping activity after the Katrina disaster, much imagery of the coast already existed, however not at such good resolution. Our inclusion of pre-spill imagery will, as participant Adam Griffith put it, ‘remind us what the land should look like’. [32] The post-spill maps will help to identify and assess the environmental and economic damage which coastal ecologies and communities have sustained.

The project is ongoing, and even after our current funding and timeline end in January, there is potential to perform ongoing mapping at longer intervals. While the immediate needs of providing imagery to the public and the media have been met, our longer term goals of using the data for litigation and environmental monitoring will require collaboration with those communities, and plans are already in motion to present the data at relevant venues.

Our choice of a blanket public domain policy has meant that with the exception of some donated imagery, all our data has been released into the public domain and may be downloaded and republished without permission. We expect this to facilitate its adoption by researchers, litigators, and other activists, just as it has amongst the media. Already, images have been republished by the Boston Globe, the New York Times, and many other news agencies. Much of the data has even be licensed to Google for use in the Google Earth and Google Maps products. This reversal — small organizations providing imagery to Google instead of the opposite — stands in contrast to the licensing bottleneck which caused so much controversy in the Haiti aid community, as discussed in Section 4.4.1.

As more such projects unfold<sup>4</sup>, I hope that the successes we have had in the Gulf Coast will not only provide a wealth of relevant information for



**Figure 8.13:** Volunteers launch a balloon at Grand Isle, Louisiana. Photo courtesy Adam Griffith

---

<sup>4</sup>See Chapter 10.1

**Table 8.1:** Success of image capture in varying weather conditions during over 33 mapping trips led by LABB and other Grassroots Mapping volunteers between May 7th and July 22nd, 2010.

Conditions	Balloon or Kite	# of images	Est. max altitude (ft)
	balloon	222	1500
	kite	184	
	kite	54	
	balloon	318	
steady wind grew to 20 mph	kite	200	1000
	balloon	118	
	balloon	182	
windy	balloon	100	350
very windy	kite		300
good wind	kite		1000
lots of wind	kite		1000
good wind	kite		1000
good	balloon	124	750
good	balloon		350
7-8 mph	balloon	362	300
poor wind	kite		500
very windy	both	213	1000/1000
good	balloon		800
	balloon	665	700
stormy	balloon		1000
low wind	kite		200
7-8 mph	balloon		400
very windy	kite		
windy	kite	472	350
low wind	both	166	
windy	kite	398	350
	kite	200	
mild steady wind	balloon	323	400
difficult wind	balloon	1000	500
	balloon	900	300-600
wind in wrong direction	balloon	50	500
	kite	325	
good wind	balloon	971	1000



other would-be mappers, but that our work will inspire others to adopt these practices in new and interesting ways.

## Chapter 9

# Evaluation

In assessing the Grassroots Mapping project, I wanted to consider not only the technical merits of the tools and their immediate use, but the success of the project as a human endeavor, and its effects on the communities involved. While there are important quantifiable benefits to the balloon- and kite-based techniques for capturing imagery and the web-based tools for processing and publishing that imagery, it is also important to address the degree to which the tools were appropriate for participating communities, and whether they felt that the tools served their needs:

- Did our maps provide better imagery/information to groups in need?
- Were the tools adopted and used? Are they financially and technically within reach of the participant communities?
- Did participants come to believe in the importance of authoring maps and the rhetorical power of mapping?
- Did the mapmaking and the ability to make maps effect change in the participant communities?
- Were the maps used in legal processes? Did they help participants advance an agenda? Did they provide critical information?

In the first two questions, the answer is clearly ‘yes’ for both the Peru and Gulf of Mexico case studies. Resolution and recency were dramatically better in the maps we produced, and especially in the oil spill mapping project, the tools have been enthusiastically adopted. Also in the oil spill mapping, LABB participants have regularly posted to the LABB blog as well as discussed the project on television and radio, demonstrating a good understanding of the goals of our effort and a strong belief in the maps’ intended role and uses.

However, the final two questions remain to be fully answered, largely because the legal, environmental, and social processes upon which they are dependent may span many years, and a comprehensive assessment must address such a longer timeframe. Outreach efforts for the oil spill data to the ecology, environmental law, and cartographic communities have begun, with participants already submitting proposals to relevant conferences and publications to promote the use of our data. It remains to be seen whether the data sees wide adoption in academic and legal use in

coming months and years. I plan to remain in contact with all participants across the several case studies discussed here to encourage and monitor whether there were positive outcomes and uses for the data.

## 9.1 Validity in openly ideological research

Many of my research questions are qualitative in nature, such as ‘Did the maps cause participants to re-evaluate their understanding of their environment in political or environmental terms?’ or ‘Did mapmaking change participants’ assumptions about what information they could access or utilize to further their interests?’ The answers to these questions are profoundly affected by my advocacy of these tools and techniques in the communities with whom I collaborated — and the degree to which I was able to convince participants to adopt these tools and the beliefs about cartography which they embody. In order to better understand the outcomes of my research, given such an ideological investment by myself and other participants, a degree of reflexivity is required. I therefore look to Patti Lather in her essay entitled ‘Reconceptualizing Validity’ where she outlines a framework for assessing validity in the context of openly ideological research. Such an approach is especially appropriate for a discipline which is increasingly understood as a qualitative field; see Section 2.2 for additional discussion on how maps are constructed and the importance of a mixed-methods approach.

Lather advocates a ‘vigorously self-aware’ regimen of research techniques which she presents in contrast to ‘positivist’ traditional practices which claim objectivity and neutrality. In the face of similar traditional cartographic claims, it is appropriate and productive to apply several of Lather’s proposed evaluative methodologies: construct validity, face validity and catalytic validity.

### Construct validity

Construct validity refers to how theory was affected by gathered data and by the human realities of the research site or context. In the case of the Grassroots Mapping case studies, the variety of sites we attempted to map, and the time, cost, materials availability, and mapping goals we established with local partners at each site dictated how we applied these technologies to specific problems. The process of making maps in these places and with these people also brought to light new ways of using and thinking about maps which has gradually changed how I approach mapmaking and present it to others. Most of all, there was a continual re-negotiation of **why** we made maps due to political, social, environmental, and economic context. This led to a shift from technological justifications such as higher resolution, better precision, and the more abstract beliefs in ‘open geodata’ to more site-specific reasoning, as well as a greater emphasis on non-quantitative results.

In Lima, Peru, we expected our claim that we could produce higher resolution imagery than available in Google Maps to inspire or incentivize participants; however most of the youth we were working with were unfamiliar with Google Maps, and comparisons did not resonate as strongly as we had hoped. However, the ability to see oneself in many of the aerial images resonated strongly with participants of all ages.

The intent of our mapping work became more tactical and aggressive at times — while these tools were originally designed to help communities map themselves, in Rock Creek, West Virginia, we



used balloon mapping to gather data about a mining site operated by Massey Energy; a hostile organization. Members of Coal River Mountain Watch considered the land to be ‘theirs’ in the sense that Massey had gained access to the site through a long history of permit and land ownership manipulations, and the mapmaking was intended to document what the company was doing ‘to Appalachia’ and the communities surrounding the site.

Another change has been the project’s increase in scope, and the application of Grassroots Mapping tools to ever-broader needs, starting with land tenure claims, and growing to include street mapping in Georgia, youth curricula in Boston, Lima, and the West Bank, and environmental monitoring in a wide variety of sites. In the Gulf of Mexico following the 2010 BP oil spill, the realization that our maps were detailed enough to see individual animals and plants became one of the most compelling justifications for the mapmaking, as did the ability to see ourselves in many images, connected to the camera by the 2000-foot tether. These discoveries broadened the scope of the mapmaking and influenced the selection of sites. In general, Grassroots Mapping has been slowly repositioned as a source for both ecologically relevant information at a high frequency of capture, and symbolically relevant imagery of events at a human scale.

In a broader sense, the project has changed most in its refocusing on collaboration and pedagogy. From the start, I have worked with a diverse group of people in prototyping and testing these tools in a variety of settings. As the project has grown, those collaborations, workshops, and the materials we have produced, including videos and illustrated guides, have become the focus of our efforts, perhaps even more than the resulting maps. An appreciation of the process and its ability to inspire and provoke civic engagement has grown to become one of the central tenets of my mapping work, and in my opinion, the key to its success.

### Face validity

The importance of creating a feedback loop where research output is reviewed and interpreted in collaboration with participants cannot be overstated, and this is the focus of ‘face validity’ as described by Lather. In Grassroots Mapping case studies, I have made every effort to process, analyze, and publish data in a participatory manner — teaching and demonstrating image selection, orthorectification tools, and discussing the pros and cons of output formats such as printed or digital maps. One of the major components of the toolkit I have developed, the Cartagen Knitter, is specifically intended to aid in the production of maps and to be a sustainable and reproducible means of creating maps with aerial imagery. I have been lucky enough to be able to iteratively test Knitter with participants of varying levels of technical literacy, and to make incremental improvements on the tool’s interface and abilities.



**Figure 9.1:** Austin Cowley of OpenMapsCaucasus and a student from Mestia, Georgia use Cartagen Knitter to join images gathered the day before from a balloon.



Ultimately, the use of maps to further the interests of participant communities lays in the hands of those participants, and over a longer timeline of months and years, it remains to be seen whether the maps I have produced with people are, for example, submitted as part of a land claim in Lima, Peru, or used to challenge a mining permit in Rock Creek, West Virginia. However, the interpretation of map data by local participants has been an essential component of the project. In a map of Black Mountain, Virginia, initial images of a reclamation site appeared in vibrant green when compared to previous data from Google Earth. Since the goal of the mapmaking was to highlight the environmental degradation the site had sustained, this was concerning, and indeed, upon first seeing the map many people comment on how beautiful the color is. Members of the Coal River Mountain Watch organization pointed out that despite the color, the main points of interest in the data are the contrast between the naturally forested areas and the sparse vegetation which had been replanted, as well as the tendency of the replantings to follow roadways — the implication being that the mining company has tried to mask the damage by planting where people would see it most.

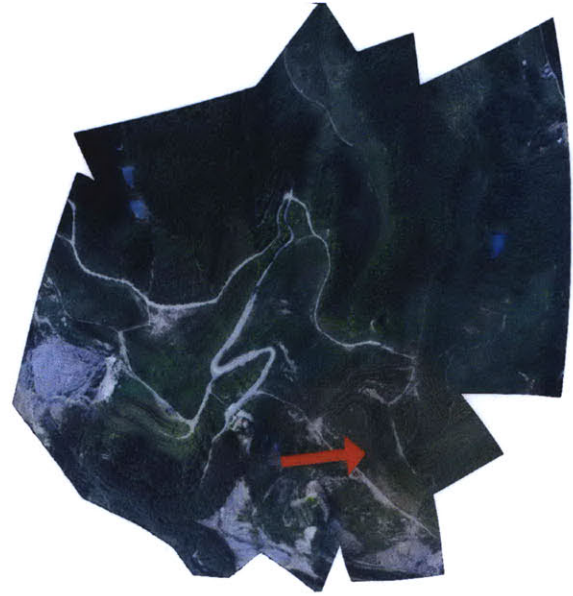

**Figure 9.2:** Roadside plantings at a mountain-top removal mining reclamation site on Black Mountain, at the Virginia/Kentucky border.

Face validity can also be assessed when participants present their work to others; in Juan Pablo II, our work culminated in an exhibition of students’ maps and drawings to parents and community leaders, who responded with excitement and even surprise. In some cases, specific wording employed by participants has hinted at the degree to which participants took ownership of the process and the resulting maps. Helder Solari, a member of the Escuelab team I worked with in Canta Gallo in Lima, Peru, tellingly referred to the map as ‘tuyo’, or yours, when he wrote to me asking for a digital copy. (I had left only paper copies with leaders of Canta Gallo.) He did make reference to the fact that our map (as I describe it) is the only one which shows the Canta Gallo community, pointing out that ‘in other maps, it simply doesn’t exist’ [73]

In the largest application of Grassroots Mapping tools in the Gulf of Mexico in 2010, participants blog posts, though from a self-selecting group, demonstrate that many amongst the mapmakers believed strongly in the project’s deeper message of cartographic testimony and democratization:

Even though we cant all be paragliding aerial photographers, wildlife experts or boat captains, we still have a role to play in raising awareness about the effects of this disaster. The best thing that ordinary people can do for the community right now is stay informed, promote action and spread the wordthis is the mission of the Louisiana Bucket Brigade in Grand Isle. — Lauren Craig of LABB, after a balloon mapping trip to Grand Isle [21]

## Catalytic Validity

One of the most important outcomes of the Grassroots Mapping project is how it has changed participants' assumptions of what kind of information they are able to collect. This is a key aspect of what Lather refers to as **catalytic validity**, 'the degree to which the research process re-orient, focusses, and energizes participants'. In the case of the 2010 BP oil spill, most organizations I spoke with initially did not understand what I meant by mapping — their response to the spill simply did not take into account the possibility that new aerial data could be captured without a satellite or an aircraft.

Most of the groups I have worked with experience a moment of excited inspiration upon seeing the first images of their own site, fresh off of a balloon flight. Members of Coal River Mountain Watch in West Virginia<sup>1</sup> expressed initial doubts that imagery would be possible due to difficult weather conditions and the challenges in finding an appropriate launch site. However, upon completing a successful flight at the nearby Marsh Fork Elementary School, the excitement was palpable. Our imagery, captured from over 4,000 ft high, proved that monitoring was possible, and the activists began discussing where to acquire the necessary materials. Participants experienced a sudden sense of empowerment, as they recognized their ability to gather direct photographic evidence of the mining companies' destructive effects on the environment.

This moment of inspiration can be frustratingly elusive. In Lima, Peru, mapmaking is performed by civil engineering firms using traditional and expensive surveying techniques. At one point, we were engaged in a mapping exercise with youth from the Canta Gallo community, when leaders of the group came in to the same room to have a meeting with one such firm over the progress of their map! Despite having shown previous maps I had made with other communities, none of the leaders seemed to be interested in applying the techniques towards their apparently immediate needs.

## 9.2 Comparison with existing techniques

One of the most compelling aspects of the balloon and kite mapping techniques was its low cost; many of the communities I worked with, including those in Canta Gallo, Lima, and Rock Creek, West Virginia, mentioned cost in particular as a motivation to try these tools. For volunteers at the Louisiana Bucket Brigade in New Orleans, it was the low cost of a mapping kit which made it possible to scale up mapping efforts to several teams, with new maps made every few days, all within a budget of only a few thousand dollars. This made kite and balloon imaging techniques feasible at low cost even before the availability of digital cameras and image manipulation tools; today the development of higher-performance kites, lighter cameras, and open source mapping software has made it even more practical. In particular, the absence of engine noise makes both kite and balloon photography more appropriate than imaging from aircraft for sensitive environmental applications such as observing wildlife without disturbing it. [2] In my own work, this was useful while mapping the BP oil spill's effects on birds and other wildlife in the Gulf of Mexico. It has also proven relevant for politically and militarily sensitive areas such as coal mining sites in Appalachia, refugee camps in Palestine.

Compared to the alternatives, of hiring pilots and paying for fuel and aircraft, or purchasing satellite

---

<sup>1</sup>See Section 10.1.1



imagery, balloon and kite mapping seemed not only inexpensive, but more legible and participatory. The idea that one would have to send a camera into space to photograph things which are right next to oneself seems strange, especially when the area of interest is on the scale of a small community. Imagery taken from only 2-4000 feet preserves a sense of the human scale; mappers can often see themselves or their boat or car in the images, and the occasional photograph shows the balloon or kite string leading down from the camera to the ground. This leaves a powerful impression on mappers, who are literally holding the camera in their hand at thousands of feet in the air... albeit at the end of a string. To them, the millimeter-thick string is both a literal and symbolic link to the camera, a reminder of their control over the image and the authorship they have in the resulting map.

In pragmatic terms, rather than relying on an outside source of expertise, members of participating communities felt that they could perform the image collection themselves, at times of their choosing, and could repeat the imaging at higher intervals than what would be possible with aircraft or satellites. After performing several trips with members of the Louisiana Bucket Brigade and members of Coal River Mountain Watch, participants from those organizations felt comfortable launching their own balloons under observation by myself or Stewart Long, another grassroots cartographer. Several of these participants went on to lead their own trips and bring back their own imagery.

## 9.3 Quantitative evaluation

### 9.3.1 Spatial resolution

Resolution can be measured in the spatial, temporal, and spectral dimensions. Spatial resolution refers to the density of information in the x, y, and sometimes z axes in the physical world. Temporal resolution refers to the frequency of image capture, and spectral resolution is the amount of color information preserved in an image<sup>2</sup>. Spatial resolution in aerial imagery is measured in meters or centimeters per pixel; that is, how many meters or centimeters in the real world correspond to the width or height of a single (presumably square) pixel of photographic data. For example, typical res-

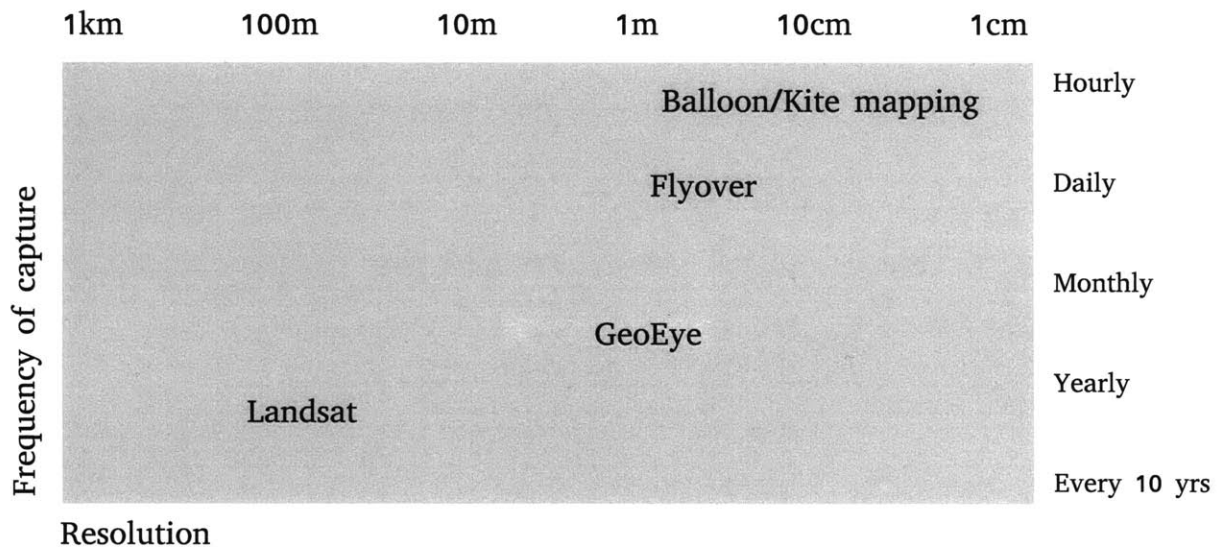

**Figure 9.3:** Grassroots mappers in a fan-boat at Bay Jimmy, LA on July 22. Photo courtesy Cesar Harada/LABB.

<sup>2</sup>More broadly defined, spectral resolution can refer to bands of data outside the range of visual light, as well as the consistency of spectral information due to sun-object-sensor geometry. [75]

olution in Google Maps for urban areas in the United States is 141 cm/pixel, due to their use of the GeoEye satellite of that resolution. This is often referred to simply as 141cm.

On a purely technical basis, there were several key benefits to the techniques employed by the Grassroots Mapping project. In terms of spatial resolution, the typical balloon or kite map ranges from 2-150 cm in resolution, depending on the camera used, the camera altitude, and the desired output resolution. This bridges an important gap in publicly accessible aerial imagery, as commercial satellites today are limited by US law to 50 cm resolution, and the GeoEye 1 satellite, which offers the best current resolution, offers only 141 cm color imagery. This is especially important in environmental applications; Vierling et al emphasize in their use of balloon imagery that ‘...there still exists a gap between canopy scale processes and landscape level satellite remote sensing measurement.’ [80] The resolution required to identify objects on the ground is typically three to five times smaller than the target objects, so to identify an object 10 cm wide, a resolution of 2-3 cm is required. [1] Jensen and Cowen cite 25 cm as the minimum resolution required to assess attributes such as quality of life indicators and post-emergency imagery. This is well within the typical resolution range for balloon and kite imagery. [35]



**Figure 9.4:** Comparison of various imaging techniques and typical resolution/frequency characteristics

Balloon and kite techniques also offer a solution to the lack of control over the timing of imagery capture. Purchasing existing satellite imagery is expensive; in Lima Peru, DigitalGlobe offers imagery from 2008-10 at US\$14 per square kilometer, however it is at only 46 cm resolution. Additionally, the imagery may be much as 2 years old and must be bought in large batches. [24] To buy new imagery often requires waiting for a satellite to pass over the target area, or hiring an airplane and pilot, and thus is even more costly, at hundreds of dollars per square kilometer. [53] In the citizen mapping of the BP oil spill in 2010, publicly available daily imagery of the spill was available only from the NASA satellites Terra and Aqua, whose MODIS imaging sensor captured a resolution of only 1 km — though each image could capture the entire oil spill. The images were further obscured by cloud cover (a common challenge with satellite imagery [51]) and glare from

the sun, although I emphasize that the MODIS imagery is extremely useful for different reasons than those captured by balloon or kite; volunteers at LABB often used MODIS imagery to identify likely sites to perform kite and balloon mapping. In fact, the two resolutions are almost impossible to reconcile, as all of the citizen maps produced by participants fit within one or two pixels of the MODIS data.

The capture resolution is, of course, a compromise between the desired surface area of coverage and the desired resolution. For example, if a balloon is flown at 1200 meters above the ground, a typical 5 megapixel point-and-shoot camera will capture an area approximately 1000 meters square **per photograph** at a resolution of approximately 40 cm. To double that resolution would require flying the balloon at an altitude of approximately 800 meters, or using a higher resolution camera. In either case, a viable way to increase coverage is to move around with the tether on the ground, either by walking or in a boat or other vehicle. This has the disadvantage of taking a lot of time — in the above example of flying at 1200 meters, to double the map extent would require walking roughly a kilometer in any direction. This is further complicated by obstacles such as closely spaced trees, power lines, etc.

### **Precision and accuracy in low-altitude aerial imaging**

Another important aspect of quantifying spatial resolution is to distinguish the internal precision of an image mosaic and the accuracy of that data compared to the real world. That is, while imagery may be highly spatially consistent in that the location of features relative to one another closely matches reality, the entire image may not be spatially correlated to the real world, and the latitude and longitude positions of those features may vary from their real-world counterparts. This may occur when an image mosaic is assembled from source images with large overlapping areas, and is internally consistent, but cannot be related to the real world due to poor GPS measurements or poor reference map data. Images are typically orthorectified against reference map data of a lower resolution, thus limiting accuracy to the resolution of that source. Further research is required to assess the accuracy and precision of large-scale balloon and kite mapping projects, using a high-resolution differential GPS for reference, following the methodology outlined in Eric Wolf's study of low-altitude balloon mapping. [85]

### **9.3.2 Temporal resolution**

Though **some** satellite imagery is publicly available for virtually every place in the world, and often at useful resolution, even those areas which are mapped at better than 1 meter resolution are often years out of date. There is simply no business case for many satellite imagery providers to capture imagery of many places in the world, and it is impossible to know when the next available dataset will be published, or under what terms. [55] The ability to **repeatedly** image an area at intervals of one's choosing makes balloon and kite mapping techniques useful for time-sensitive purposes such as periodically monitoring the effects of the Gulf oil spill (see Chapter 8) or measuring vegetative regrowth in mountaintop removal mining sites undergoing reclamation (see Section 10.1).



### 9.3.3 Spectral resolution

Aerial imagery taken from low altitudes (under 4000 ft) typically has better color saturation compared to imagery captured from space or from higher altitude aircraft platforms. Spectral resolution also refers to consistency, however, and due to sun glare and angle of capture, spectral resolution tends to be quite poor when imagery is captured near solar noon. Balloon and kite imagery does benefit from being captured from below the level of the clouds, which can be important for environmental assessment. Also advantageous is the ability to obtain uncompressed RAW format image data; for example, Crispen Wilson of Conservasi, a member of the Grassroots Mapping mailing list, is attempting spectral analysis of aerial imagery over water. Most easily accessible aerial or satellite imagery is published as PNG or JPEG tiles, and is not useful for such purposes.

Spectral resolution is important for identification of vegetation, and Miyamoto et al have achieved classification of vegetation into 27 different types such as 'moss with alpine plants' and 'moss bogs with pools', using 15 cm imagery. They also assert their belief that balloon aerial photography may be used to allow classification to the genus and species level. [51] Their work has obvious relevance to both the citizen mapping of the BP oil spill (see Chapter 8) and Coal River Mountain Watch's mapping of mountaintop removal mining reclamation sites (see Section 10.1).

## Chapter 10

# Conclusions and future work

### 10.1 Ongoing uses of Grassroots Mapping tools

#### 10.1.1 Activist mapping with Coal River Mountain Watch

A variety of new projects have been initiated both with and without my prompting or intervention, in order to apply Grassroots Mapping tools towards different goals. One which I had the pleasure of collaborating on directly was a mapmaking pilot project with the Coal River Mountain Watch (CRMW) community, an activist and advocacy organization based in Rock Creek, West Virginia. CRMW works to educate and disseminate information about mountaintop removal mining (MTR) practices in Appalachia, in which companies such as Massey Energy remove entire mountaintops to access coal seams, depositing the ‘waste’ rock in nearby valleys. What results is extreme environmental degradation and a variety of health hazards from water table contamination, landslides, and particulate air pollution. CRMW was interested in using balloons, kites, and remote controlled airplanes.

In collaboration with Stewart Long of GonzoEarth, I joined photographer Chris Eichler in attending the Mountain Justice conference at Wiley’s Last Resort, in Kentucky. There and subsequently in Marsh Fork, West Virginia, we created a series of maps of mining-related sites. Our first depicts the bright green of a reclamation site, where a mining company has attempted to replant a former MTR site. Rob Goodwin of CRMW and other activists who performed the mapping pointed out that the green color is due to a thin layer of invasive weed which is sprayed over reclamation sites from airplanes. The coverage is thin and

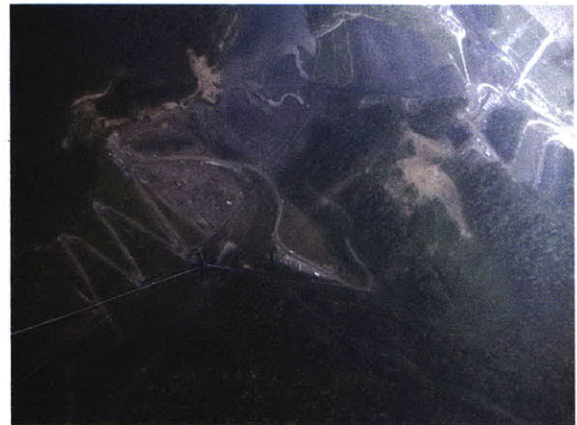

**Figure 10.1:** A balloon photograph of a mountaintop removal mining site at Cherry Pond Mountain, West Virginia, captured from over 4000 ft above ground level.

there is little or no topsoil over what is essentially a pile of broken-up rock. Aerial imagery shows the contrast between this kind of so-called replanting and the natural forest surrounding the site. It also depicts several contaminated ponds and highlights the tendency of mining companies to plant bushes and shrubs mainly along roadways.

At the Marsh Fork Elementary school near CRMW headquarters, we launched a balloon to over 4000 feet above ground level, breaking all our previous records for altitude, and captured photos of a runoff pond and an active mining site above the school. By using an electric power drill to reel in the tether, we reduced deployment time, though in that case we ran out of battery for the drill and were forced to revert to hand-reeling. The potential to do power-assisted reeling makes such high-altitude flights more reasonable in a limited time frame, allowing for shorter intervals between flights. With enough power to run a drill, over 1000 feet can be reeled in every 2 minutes.

An additional advantage to balloon imagery is that it can be captured inconspicuously from public roads upwind of target sites. These tools provide groups such as CRMW access to time-sensitive information about the progressive degradation of the environment, and CRMW hopes to use the data in court cases to prevent mining operations.

### **10.1.2 A Grassroots Mapping collaboration in Georgia**

In early 2010, Jeff Haack of JumpStart International, the nonprofit group which implemented the Free Map Palestine project with Mikel Maron in 2008-9, expressed interest in applying Grassroots Mapping tools and ideas to a nation-wide mapping project in the country of Georgia. With educational projects in 9 cities across the country, this was to be the first large-scale explicitly educational application of the Grassroots Mapping concept. In Georgia, JumpStart had focused on creating a locally-operated nonprofit called OpenMapsCaucasus (OMC) to direct mapping efforts. Beginning in June 2010 and lasting 6 weeks, the collaborative program consisted of a series of workshops and trainings with OMC-affiliated educators and activists using balloons and kites.

The creation of OMC, a fully Georgian organization, reflects JumpStart's interest in building long-term technical expertise and interest in open-source, civil society centered projects in Georgia. Haack elaborated on this aspect of the project in a comment on Mikel Maron's blog in the spring of 2010:

The NGO structure JumpStart has built in Georgia is, in my opinion, an apt and sustainable way forward. After our experience in Palestine it became clear that impact requires a lasting effort in a community and the encouragement of local skills and ownership. Its not merely about mapping a country, but about understanding where that, conceptually, meets societal needs, and building value therein. Sustainability for OMC comes by understanding the convergence of digital technologies with community mapping, social fabric, governance, and civil society, and filling a need within that sphere. Were not expecting OMCs community mapping focus to last forever, but that concept, at the very heart of it is meaningful and sustainable, because accessing the tools for extracting and considering not oil or timber, but information, strengthens a society and can make it more prone to long term development.

<http://brainoff.com/weblog/2010/04/28/1556>





**Figure 10.2:** A map of Mestia, in the Svaneti region of Georgia. The map spans 5.5 kilometers, and was captured in just 3 days of balloon and kite mapping with local OpenMapsCaucasus staff and participating students.

The trip also afforded me an opportunity to push the techniques to their limits. With a small but dedicated team of mappers in Mestia, in the far northern region of Svaneti, we set out to create the largest and most complete map of an entire city to date. Our end result, captured over three days of kite and balloon flights, and reaching altitudes of over 1.4 kilometers, covered most of the city of Mestia, and spanned over 5.5 kilometers in length. Using the new [TMS](#) export feature of the Cartagen Knitter, this dataset will allow [OMC](#) mappers to trace buildings, pastures, roads, and other features in [JOSM](#) faster and more efficiently than ever before.

## 10.2 Outreach

There has been a great deal of interest from both technology enthusiasts (kite, RC airplane, and geo-programmers alike) and organizations working in local communities to implement Grassroots Mapping tools and techniques. Part of the ongoing development of this community will be the brokering of relationships between these two communities, and the matchmaking of those with technical know-how with those in need of geospatial information and training. The Grassroots Mapping mailing list incorporates representatives of both of these groups, and as such will continue to be the central organization point for such collaborations. I plan to organize meetup sessions in key areas to bring these communities together in a hands-on, workshop setting, where personal connections and professional relationships can evolve.

## 10.3 Illustrated Guides

Originally suggested in early 2010 by Grassroots Mapping community member Pat Coyle, the idea of an illustrated guide to provide a rich and cross-language instruction set has received some attention in the intervening months. Storyboarding, outlining, and initial sketches were begun in the spring of 2010 by Pat Coyle and Nathan Cooke of MIT's D-Lab, based on requests by other mailing list members for a simple guide which spelled out how to produce balloon maps step by step. Published in May 2010, the 4-page guide (reprinted in Appendix C) developed for the Louisiana Bucket Brigade was a quick attempt to provide such instructions, but was primarily intended to serve as an organizational guide and checklist, with tips and reminders, rather than a complete start-to-finish guide.

Ultimately I published a more complete 5-page illustrated guide (reprinted in Appendix B) for the Georgian mapping project of July 2010, rendered in black and white for easy photocopying. A translation in Georgian was produced by OMC and distributed amongst interested mappers across the country. This guide attempts to capture and simply convey many of the small details which make the balloon mapping techniques successful, such as tips for a more stable camera mounting using rubber bands, and instructions on how to make inexpensive balloons from trash bags. While there is no replacement for face-to-face instruction, I hope that the guides will be a compact and clear means to convey Grassroots Mapping techniques to a wider audience, and more translations are planned, including Spanish and Arabic.

## 10.4 Conclusions

The large number of continuing efforts and high interest in further mapping work of this kind in places such as the Philippines, Belize, Sumatra, Palestine, Nigeria, and elsewhere indicate that the central mission of the project has resonated with a wide audience. However, the work thus far represents only the groundwork for a broader effort to promote a more inclusive cartography. Future work may include the development of semi-automated techniques for stitching imagery, the development of yet less expensive means to lift cameras, perhaps employing solar heating, and further refinement of the instructional materials which accompany the Grassroots Mapping Kit. Other directions include the generation of digital elevations models from balloon imagery, and expanding sensory equipment to far-infrared, air quality, and other sensors.

It is my hope that such new directions, along with the continued publication of new and exciting map imagery from Grassroots Mappers around the world will inspire individuals and communities



**Figure 10.3:** Flight paths of several balloon mapping flights in Mestia, Georgia, during a 3-day project to map the entire city. The pictured flights reached 1.4 kilometers above ground level.

to challenge existing forms of cartography. Such explorations will not only advance the the abilities of would-be cartographers, but promote the belief that maps and mapmaking can effect positive change in the world.



# Appendix A

## Maps

The following maps are included in the attached DVDs.

### A.1 Maps from Lima, Peru

- Juan Pablo II
- San Ignacio Loyola
- Canta Gallo I
- Canta Gallo II

### A.2 Maps from the 2010 BP Oil Spill

- Port Fourchon, Louisiana
- North Chandeleur Islands, Louisiana
- South Chandeleur Islands, Louisiana
- Grand Isle Terre, Louisiana
- Long Beach, Mississippi

### A.3 Maps from Georgia

- Mestia, Svaneti, Georgia

## Appendix B

# Illustrated Guide to Grassroots Mapping

# An Illustrated Guide to Grassroots Mapping with Balloons or Kites

By Jeffrey Warren (v1.1)

Do you want to make maps? Do you need satellite images but can't afford them? Do you want to see your home from above? Follow these instructions and you can, for as little as \$100!

To learn more, visit <http://grassrootsmapping.org>

## What you'll need:

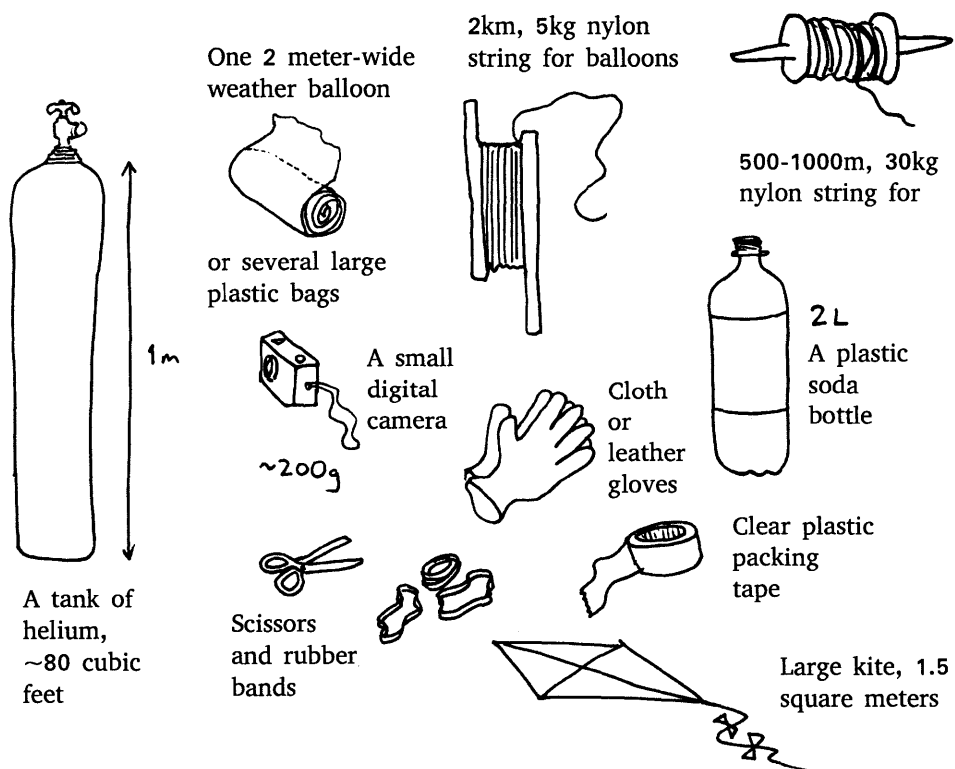



## Balloon or kite?

Decide whether to use a balloon or a kite. Prepare for both; you won't know until the day comes:

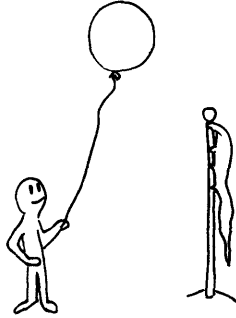

In wind below 10kph,  
fly a balloon.

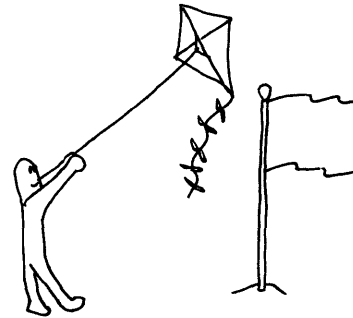

In wind above 10kph, fly a kite.  
Look at a flag to decide.

## Build your camera capsule

This simple protective cover stops your lens from hitting the ground, and protects your camera from hitting walls and trees.

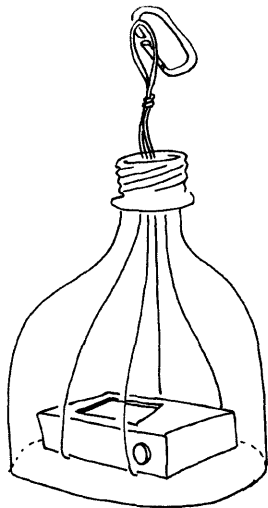

A rubber band through a second knot can be used to pull the camera snugly against the bottle.

Cut a soda bottle in half and put the camera inside the top with the loop through the bottle neck.

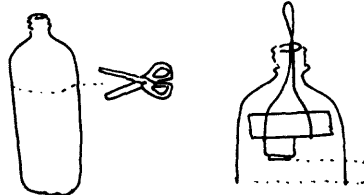

Tape on some cardboard 'wings' to stabilize it in the wind.

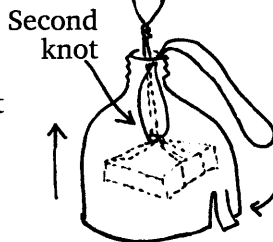
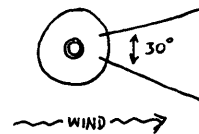
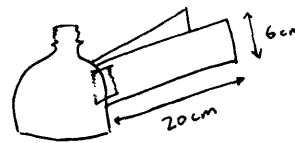

Pull the rubber band out the top and hook it on a tab cut on the bottom of the bottle

## Prepare your camera

Any digital camera around 2-300 grams that has a 'continuous mode' can work. You can also use a Canon camera with the CHDK to trigger a photo every 5 seconds.

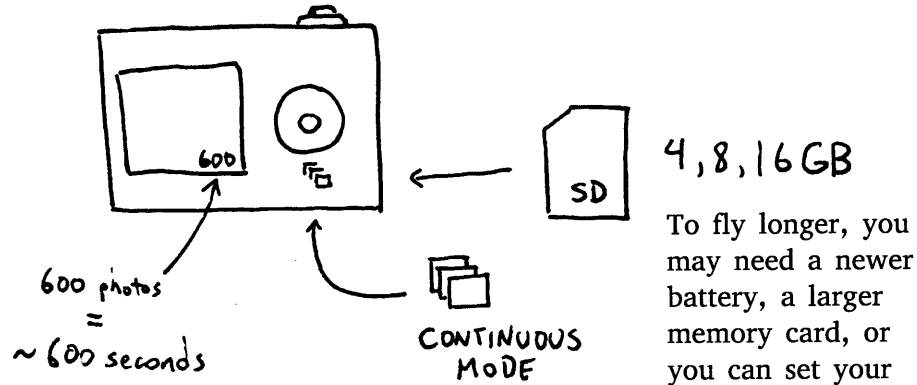

In 'Continuous Mode' a camera takes a picture every 1 second if the trigger is held down. Your display will show how many pictures you have.

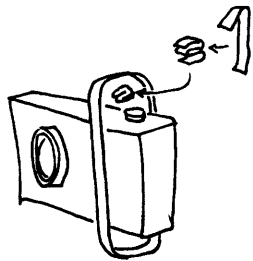

Wad up a bit of card paper or use a pencil eraser to hold down the camera trigger. Use a rubber band to hold it in place and apply pressure. Be sure the button is being pressed.

Move the rubber band to one side until you're ready to start.

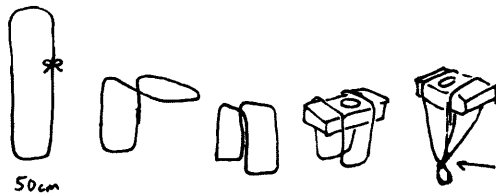

Fold a loop of string and tape it firmly onto your camera. Be sure the tape doesn't stop the lens from extending.

Press the tape down hard - its the only thing keeping your camera from slipping out of the string at 500 meters high!

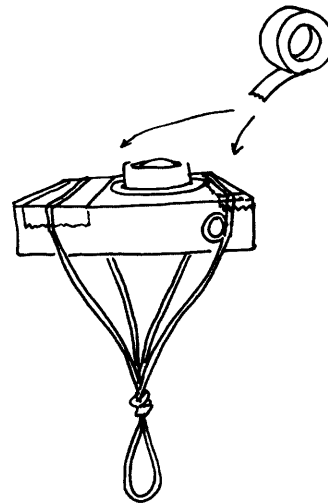

# Building and filling the balloon

If you can't get a big enough balloon, you can make one from giant trash bags. White plastic works best - you'll need a 1.75m x 3m sheet.

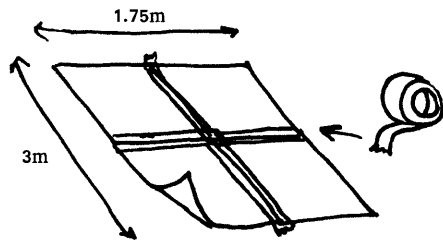

Fold the rectangle in half, and tape the sides. Open the 'pocket' until it closes vertically, then tape that shut too.

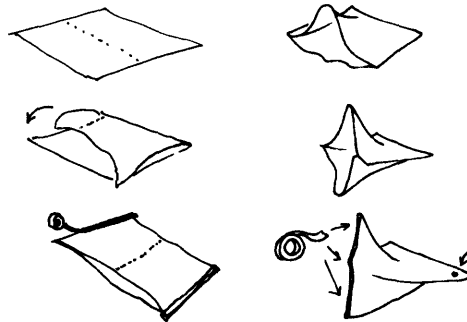

Cut open the bags into rectangles, and tape them together into a larger rectangle.

Be sure to do this on a smooth, clean floor or a blanket so you don't puncture the bags.

Punch a hole in one corner to fill the bag.

Hold the balloon onto the valve and fill slowly and carefully.

As the balloon fills it will rise and twist the neck, so hold it down gently.

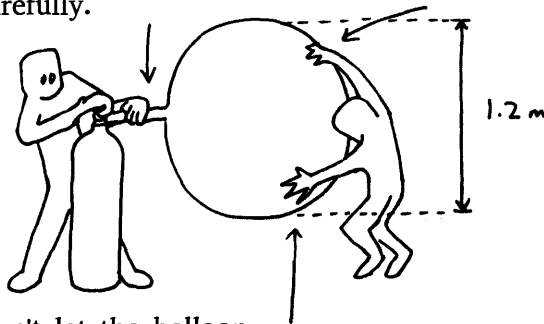

When you're ready to attach the camera to the kite or balloon string, tie a knot in a loop of string and clip on the camera.

Don't let the balloon touch the ground!

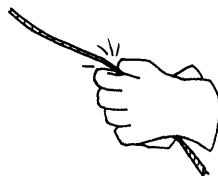
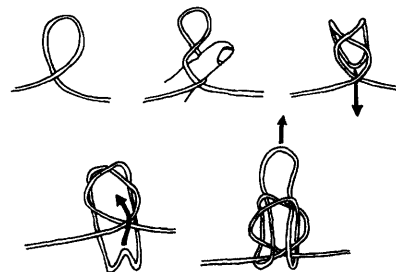

Always use gloves when flying kites - the string can burn your hands!



## Flying your balloon or kite

The highest wind is usually around 2pm, and the lowest is at dawn. Bring water and sunscreen if it's hot out, and charge your camera batteries the night before!

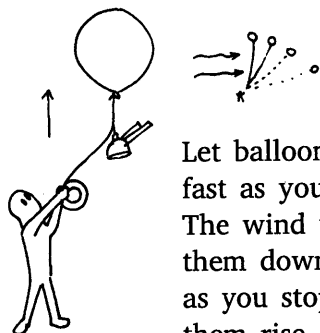

Let balloons rise as fast as you can. The wind will push them down as soon as you stop letting them rise.

When using kites, be sure there is at least 5kg of pull, and let out 20 meters of string before making a loop and attaching the camera.

When using balloons, attach the camera just below the balloon.



Wind the string carefully - don't let it tangle!

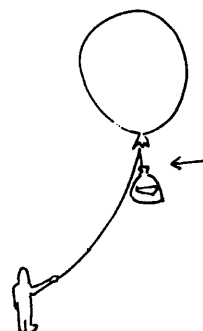
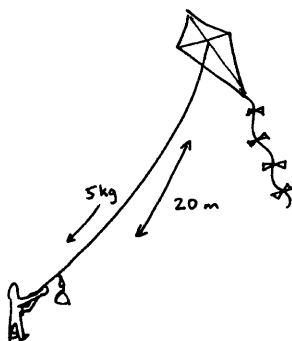

The camera has a field of view of roughly 45 degrees.

Bring a GPS if you have one, and write down the latitude and longitude.

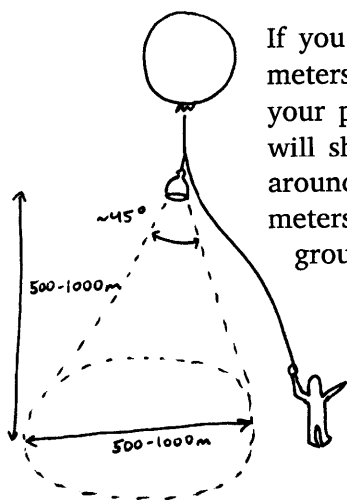

If you fly 1000 meters high, your pictures will show around 1000 meters on the ground.

A small map usually takes around 2 hours to make.

Once the balloon is 500-1500 meters high, try walking around to take pictures of a greater area.

## Appendix C

# Guides and checklists to Grassroots Mapping for the BP Oil Spill



# Mapping Checklist

*Be sure everything is in your bag before leaving!*

## **A** Your bag should contain:

- A camera with auto-shooting** (test it!)
- TWO sets of FULLY CHARGED batteries**
- 1500' of string on a reel, no tangles**
- At least one weather balloon in a protective ziploc** (two is best, or bring giant trash bags as backup)
- Gloves to protect your hands from burn**
- Duct tape AND clear packing tape**
- Scissors or a knife**
- Soft cotton string to tie everything together** (holds balloons better and cuts easier)
- A soda bottle with wings:**

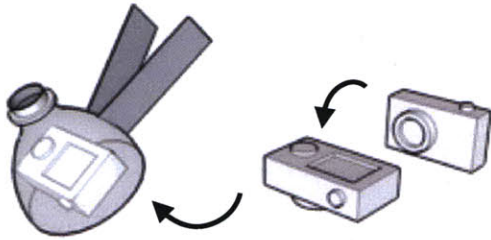

## **Optional:**

- A large kite (16 sq ft or more)**
- A GPS or an iPhone or Android phone to get a latitude/longitude point**  
(so we can make it into a map)

## **B** You also need HELIUM from:

- Louisiana Bucket Brigade HQ, 4226 Canal St, New Orleans**

- Party City** (one \$45 medium tank, \$100 deposit)

**Party City** (9-9pm mon-sat, 11-6pm sun)  
1545 Lapalco Boulevard  
Harvey, LA 70058-3300  
(504) 362-8008

**Party City** (9-9pm mon-sat, 11-6pm sun)  
3009 Veterans Memorial Boulevard  
Metairie, LA 70002-6046  
(504) 831-9944

- Anywhere else, just bring > 50 cubic feet, but small enough to carry.**

## **C** Finally, bring people:

- See [GrassrootsMapping.org/volunteers](http://GrassrootsMapping.org/volunteers)**
- Give them directions or carpool**
- Teach them how, don't do it all yourself**





# Mapping Overview

*A brief summary of the whole thing*

---

## **A** Starting your trip:

- \* Louisiana Bucket Brigade is hosting the **equipment bags** - go pick on up the night before and confirm that everything's there.
- \* Be sure to bring some new people - folks who will hopefully lead their own trips soon
- \* Charge batteries the night before!
- \* Pick up helium at Party City - see Checklist for addresses

## **B** While you're mapping:

- \* Try to map an area that's been mapped before, so we can compare.
- \* If you have an smartphone, enable the geotagging for the camera, and take a picture while you're flying
  - \* This will capture a location; submit the photo with your data and we'll be able to see where you were
  - \* To enable this on your iPhone, click the Settings icon > General > Location Services.
  - \* For Android, in the Camera app, press Menu, then Settings > Store location. Wait for the green 'GPS' icon:



## **C** Keep safety in mind:

- \* Wear protective gear when dealing with contaminated water/land
  - \* protective suit, oil resistant gloves, safety goggles, face respirator, slip resistant boots
- \* Don't handle oiled wildlife unless you're trained to do so!

## **D** Before you go home:

- \* Thank the boat captain! See if we could get another ride in the next few days
- \* Go over the checklist again to be sure you return everything
- \* Identify any potential trip leaders from your team, who could map on their own
- \* Leave a copy of your data with Louisiana Bucket Brigade
- \* Please make 3-5 reports on the Oil Spill Crisis Map ([oilspill.labucketbrigade.org](http://oilspill.labucketbrigade.org)) when you get back from your trip!
  - \* Reports boats deploying boom, dolphins swimming in oil or sheen on the water
  - \* Focus on what you see or smell, your location and capture pictures or video clips.
  - \* Quick tip: simply take a picture of the GPS on the boat or write down the coordinates.
  - \* Submit these reports online or when you return to LABB to drop off your equipment.



# Camera Guidelines

*Be sure you can use your camera before leaving!*

This is for a:  
Canon SD1000

## A Basic usage:

- \* Test your camera before you leave!
  - \* Just turn it on; it should flash a red icon and start snapping!
- 
- (Logo)
- \* You should see: “Intervalometer” and it should beep and snap a picture within a few seconds
  - \* If it doesn't, take a picture normally, and it should start.
  - \* To turn the camera off when you're done, just take out the battery.
  - \* After flights, check your photos to see if they came out.
    - \* The camera should be in “auto” mode, so exposure etc. should be fine.
    - \* If images are blurry there may not be enough light, or it may be too windy.

## B Troubleshooting:

- \* Check if the memory card is in the ‘Locked’ position. There's a little slider; lock it. The script won't run if it's not locked, weird, huh?
- \* If your camera keeps turning off by itself (either after a dozen shots, or sometimes in the middle of a flight) you need to charge the battery to 100%. If your battery is old, you may need a new battery.
- \* If you simply cannot get it to start auto-shooting, try:
  - \* Turn the camera off
  - \* Turn it on in “Review” mode
  - \* Press Menu and go down to the last option, which should be “Firmware update”
  - \* Click OK and quickly switch into “Capture” mode
  - \* You should see the red CHDK screen and it should start. You may need to manually take a picture to start it.

## C When you get home:

- \* Save a copy of the images in a safe place: a CD/DVD or backup drive
- \* Then send us the pictures and we'll publish them. Choose:
  - \* Upload the data to <http://grassrootsmapping.org/upload>
  - \* Put a copy on a USB key or a DVD, and get it to:  
*LA Bucket Brigade, 4226 Canal St. New Orleans, LA ZIPCODE*

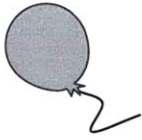

# Balloon/Kite Flying Guide

*The best way to learn is to do it with someone who's done it before*

---

?

## Kite or Balloon?

- \* In general, kites are good in more than 15 mph and balloons in less than 10 mph wind. Check a weather website. Wind is highest at 2pm, lowest at dawn.
- \* Kites are expensive but balloons require helium.
- \* Kiting is hard. Learn from an experienced kiter, and try it closer to home before committing to a mapping trip.

K

## Kiting

- \* First get the kite flying. You need a large kite (more than 10 square feet, like a Sutton Flowform 16).
- \* Get the kite in the air at least 50 feet and make sure it's pulling more than 10 lbs consistently.
- \* Make a loop (take some slack and knot it) and clip the camera in its rig onto the loop. Start your camera and let it up.
- \* Keeping tension on the line, or pulling on it, makes the kite fly higher. Letting it out makes it drop, so do it slowly.
- \* Walk around to cover a large area.

B

## Ballooning

- \* If you're using a trash bag, tape the bag shut carefully with clear packing tape.
  - \* Puncture it 2 inches away from the seam, so the tape won't interfere with your filling.
  - \* Don't do this on rough ground or you'll puncture the trash bag.
- \* Pull the hole over the nozzle of the tank. bunch up some plastic around the nozzle and hold it tightly shut.
  - \* Watch out! Keep your fingers away from where the helium will come out!
- \* Starting very slowly, inflate the balloon. It should be about 5 feet wide, and should pull strongly up, i.e. 2-3 lbs. Use your height as a size guide.
  - \* Have a friend hold the balloon in place while it fills. Don't let it touch ANYTHING sharp!
  - \* Don't let go of the balloon! Always have someone in charge of holding on to it tightly!
- \* Tie off the balloon with a VERY good knot. Clove hitch recommended (youtube or google it). Practice this knot.
- \* Make a loop 6 inches below the balloon. Test all knots, and connect the camera.
- \* Turn on the camera and make sure it's auto-shooting; listen for beeps.
- \* Let the balloon rise as fast as you can; as soon as you resist it, the wind will blow it down.
- \* Walk around to cover a large area.



# Bibliography

- [1] J.S. Aber, S.W. Aber, and F. Pavri. Unmanned Small Format Aerial Photography from Kites Acquiring Large-Scale, High-Resolution, Multiview-Angle Imagery. *International Archives of Photogrammetry Remote Sensing and Spatial Information Sciences*, 34(1):1–6, 2002.
- [2] J.S. Aber, R.J. Sobieski, D.A. Distler, and M.C. Nowak. Kite aerial photography for environmental site investigations in Kansas. *Transactions of the Kansas Academy of Science (1903)*, 102(1):57–67, 1999.
- [3] Agre, Philip E. Real-time Politics: The Internet and the Political Process. *The Information Society*, 18:311–331, 2002.
- [4] Announcing the official DIY Drones Trust Time Trial (T3) Contest. <http://diydrones.com/profiles/blog/show?id=705844:BlogPost:91103>.
- [5] T3, Round 4: Map a quarter-kilometer! <http://diydrones.com/profiles/blog/show?id=705844:BlogPost:123792>.
- [6] Congrats to the winners of T3-4! <http://diydrones.ning.com/profiles/blogs/congrats-to-the-winners-of-t34>.
- [7] The National Security Archive. Eyes on saddam: U.s. overhead imagery of iraq. <http://www.gwu.edu/~nsarchiv/NSAEBB/NSAEBB88/>, 2003.
- [8] Charles Arthur. Ordnance survey launches free downloadable maps. <http://www.guardian.co.uk/technology/2010/apr/01/ordnance-survey-maps-download-free>, 2010.
- [9] Incorporated Bentley Systems. User guide: Warp tool. <http://docs.bentley.com/en/I-RASB/irasbhelp171.html>, 2010.
- [10] J. Boike and K. Yoshikawa. Mapping of periglacial geomorphology using kite/balloon aerial photography. *Permafrost and periglacial processes*, 14(1):81–85, 2003.
- [11] Jorge Luis Borges and Adolfo Bioy Casares. *Del rigor en la ciencia*. Emece Editores, Buenos Aires, 1946. Translation by Norman Thomas de Giovanni, Penguin Books, 1975.
- [12] M.N.K. Boulos, J. Warren, J. Gong, and P. Yue. Web GIS in practice VIII: HTML5 and the canvas element for interactive online mapping. *International Journal of Health Geographics*, 9(1):14, 2010.
- [13] A. Buerkert, F. Mahler, and H. Marschner. Soil productivity management and plant growth in the Sahel: potential of an aerial monitoring technique. *Plant and Soil*, 180(1):29–38, 1996.
- [14] Claudia Canepa. New information technologies in the old political economy : an exploration of community-based GIS for improving basic services for the poor in New Delhi, India. Master’s thesis, Massachusetts Institute of Technology, 2005.
- [15] R. Chambers. Participatory mapping and geographic information systems: whose map? Who is empowered and who disempowered? Who gains and who loses? *The Electronic Journal of Information Systems in Developing Countries*, 25(0), 2006.

- [16] R. Chambers. Participatory mapping and geographic information systems: whose map? Who is empowered and who disempowered? Who gains and who loses? *The Electronic Journal of Information Systems in Developing Countries*, 25(0), 2006.
- [17] S. Chilton. Crowdsourcing is radically changing the geodata landscape: case study of OpenStreetMap. In *Proceedings, 24th International Cartographic Congress*, 2009.
- [18] COFOPRI. Mision. <http://www.cofopri.gob.pe>, 2010.
- [19] J.T. Coppock and D.W. Rhind. The history of GIS. *Geographical information systems: Principles and applications*, 1:21–43, 1991.
- [20] another prototype. <http://www.youtube.com/watch?v=mnGjw0nJQ3Q>.
- [21] Lauren Craig. Two Days on Grand Isle. <http://labucketbrigade.wordpress.com/2010/05/27/two-days-on-grand-isle/>.
- [22] H. De Soto and M.V. Llosa. *The other path: the invisible revolution in the Third World*. Harper & Row New York, 1989.
- [23] Hernando de Soto. *El otro sendero: la revolucin informal*. Instituto Libertad y Democracia, 1987.
- [24] DigitalGlobe. Mapmart. <http://maps.mapmart.com/>, 2001.
- [25] Shannon Dosemagen. "Hey, what are yall picking up on the beach?"... <http://labucketbrigade.wordpress.com/2010/05/17/%E2%80%99Chey-what-are-y%E2%80%99all-picking-up-on-the-beach%E2%80%9D/>.
- [26] Sara Elwood and Meghan Cope. *Introduction: Qualitative GIS: Forging mixed methods through representations, analytical innovations, and conceptual engagements*. SAGE Publications, Ltd, 2009.
- [27] Sarah Elwood. *Multiple representations, significations, and epistemologies in community-based GIS*. SAGE Publications, Ltd, 2009.
- [28] Institute for Applied Autonomy. *Tactical Cartographies*. Journal of Aesthetics & Protest Press, 2008.
- [29] Rich Gibson and Schuyler Erle. *Google Maps Hacks*. O'Reilly Media, 2006.
- [30] Alan Glennon. Grassroots crisis mapping. In *spatial@UCSB*. Slideshare.com, 2010.
- [31] M. Goodchild. NeoGeography and the nature of geographic expertise. *Journal of Location Based Services*, 99999(1):1–15, 2009.
- [32] Adam Griffith. Isle Grand Terre: oil pools and foul fumes. <http://labucketbrigade.wordpress.com/>.
- [33] Full text of Colin Powell's speech — World news — guardian.co.uk, Project Website. <http://www.guardian.co.uk/world/2003/feb/05/iraq.usa>.
- [34] Roger Hart. Children as community researchers. <http://www.unicef.org/teachers/researchers/intro.htm>, 2001.
- [35] J.R. Jensen and D.C. Cowen. Remote sensing of urban/suburban infrastructure and socio-economic attributes. *Photogrammetric Engineering and Remote Sensing*, 65:611–622, 1999.
- [36] Jeremijenko, Natalie and Bratton, Benjamin. Suspicious Images, Latent Interfaces. *The Situated Technology Pamphlet Series*, 3, 2008.
- [37] P. Lather. Issues of validity in openly ideological research: Between a rock and a soft place. *Interchange*, 17(4):63–84, 1986.
- [38] Helium Dispersion Through HDPE. <http://www.headfullofair.com/2010/06/25/helium-dispersion-through-hdpe/>.
- [39] Stewart Long. personal communication, 2010.

- [40] A. A. Lotliker, R. S. Mupparthy, S. K. Tummala, and S. R. Nayak. Evaluation of high resolution MODIS-Aqua data for oil spill monitoring. In *Society of Photo-Optical Instrumentation Engineers (SPIE) Conference Series*, volume 7150 of *Society of Photo-Optical Instrumentation Engineers (SPIE) Conference Series*, January 2009.
- [41] Mikel Maron. [http://www.flickr.com/photos/mikel\\_maron/3081214323/](http://www.flickr.com/photos/mikel_maron/3081214323/).
- [42] Mikel Maron. Openstreetmap for activism. In *Maps for Making Change*. Maps for Making Change, 2010.
- [43] Brain Off Misconceptions and Objections to Gaza Mapping: My Response :: Mikel Maron :: Building Digital Technology for Our Planet. <http://brainoff.com/weblog/2009/01/12/1389>.
- [44] Brain Off Freedom and Restrictions in Open Data :: Mikel Maron :: Building Digital Technology for Our Planet. <http://brainoff.com/weblog/2010/06/03/1620>.
- [45] Brain Off Haiti OpenStreetMap Response :: Mikel Maron :: Building Digital Technology for Our Planet. <http://brainoff.com/weblog/2010/01/14/1518>.
- [46] Patrick Meier. Haiti: Taking Stock of How We Are Doing. <http://blog.ushahidi.com/index.php/2010/02/06/ushahidi-how-we-are-doing/>.
- [47] Patrick Meier. Here Come the Crowd-Sorcerers: How Technology is Disrupting the Humanitarian Space and How Easy It Is. <http://irevolution.wordpress.com/2010/07/27/crowd-sorcerers-episode1/>.
- [48] Patrick Meier. Twitter vs. Tyrants: Ushahidi and Data Verification. <http://irevolution.wordpress.com/2009/10/27/twitter-vs-tyrants-ushahidi/>.
- [49] Patrick Meier. Wag the Dog, or How Falsifying Crowdsourced Data Can Be a Pain. <http://irevolution.wordpress.com/2010/04/08/wag-the-dog/>.
- [50] Patrick Meier. Where I Disagree with Morozov vs Shirky on Digital Activism. <http://irevolution.wordpress.com/2010/01/07/morozov-vs-shirky/>.
- [51] M. Miyamoto, K. Yoshino, T. Nagano, T. Ishida, and Y. Sato. Use of balloon aerial photography for classification of Kushiro wetland vegetation, northeastern Japan. *Wetlands*, 24(3):701–710, 2004.
- [52] How dictators watch us on the web. <http://www.prospectmagazine.co.uk/2009/11/how-dictators-watch-us-on-the-web/>.
- [53] PJ Mumby, EP Green, AJ Edwards, and CD Clark. The cost-effectiveness of remote sensing for tropical coastal resources assessment and management. *Journal of Environmental Management*, 55(3):157–166, 1999.
- [54] Deepwater Horizon/BP Oil Spill: Federal Fisheries Closure and Other Information. [http://sero.nmfs.noaa.gov/deepwater\\_horizon\\_oil\\_spill.htm](http://sero.nmfs.noaa.gov/deepwater_horizon_oil_spill.htm).
- [55] Sean O'Connor and the Tactical Technology Collective. Maps for advocacy: an Introduction to Geographical Mapping Techniques, 2008.
- [56] O. Okolloh. Ushahidi, or testimony: Web 2.0 tools for crowdsourcing crisis information. *Change at Hand: Web 2.0 for Development*, page 65, 2009.
- [57] Jen Osha and Daniel Weiner. Participatory GIS - A Paradigm Shift in Development? *Directions Magazine*, 2006.
- [58] Disputes. [http://wiki.openstreetmap.org/wiki/Disputes#On\\_the\\_Ground\\_Rule](http://wiki.openstreetmap.org/wiki/Disputes#On_the_Ground_Rule), 2007.
- [59] Humanitarian OSM Team. [http://wiki.openstreetmap.org/wiki/Humanitarian\\_OSM\\_Team](http://wiki.openstreetmap.org/wiki/Humanitarian_OSM_Team).
- [60] OpenStreetMap statistics. [http://www.openstreetmap.org/stats/data\\_stats.html](http://www.openstreetmap.org/stats/data_stats.html).
- [61] Marianna Pavlovskaya. *Non-Quantitative GIS*. SAGE Publications, Ltd, 2009.



- [62] Efforts to Limit the Flow of Spill News. <http://www.nytimes.com/2010/06/10/us/10access.html>.
- [63] Peter Poole. Is there life after tenure mapping? *Participatory Learning and Action: Mapping for change: practice, technologies and communication*, page 41, 2006.
- [64] Peter Poole and First Peoples Worldwide/Local Earth Observation. Information: the First Conservation Asset: A Demonstration and Training Project to Amplify Indigenous Community Capacities in Environmental Information Management, 2007.
- [65] Urban Tapestries: Bodystorming. <http://research.urbantapestries.net/bodystorming.html>, 2003.
- [66] G. Rambaldi, R. Chambers, M. McCall, and J. Fox. Practical ethics for PGIS practitioners, facilitators, technology intermediaries and researchers. *Participatory Learning and Action: Mapping for change: practice, technologies and communication*, page 106, 2006.
- [67] G. Rambaldi, P.A.K. Kyem, M. McCall, and D. Weiner. Participatory spatial information management and communication in developing countries. *The Electronic Journal of Information Systems in Developing Countries*, 25(0), 2006.
- [68] S. Rana and T. Joliveau. NeoGeography: an extension of mainstream geography for everyone made by everyone? *Journal of Location Based Services*, 3(2):75–81, 2009.
- [69] The United States? <http://www.radicalcartography.net/>, 2003.
- [70] Campbell Robertson. Oil Leaking Underwater From Well in Rig Blast. <http://www.nytimes.com/2010/04/25/us/25rig.html>.
- [71] United States Senate Select Committee on Intelligence. Report of the Select Committee on Intelligence on the U.S. Intelligence Communitys Prewar Intelligence Assessments on Iraq. <http://www.gpoaccess.gov/serialset/creports/iraq.html>.
- [72] Jaideep Sen. Shanty home. [http://timeoutbengaluru.net/aroundtown/aroundtown\\_feature\\_details.asp?code=59](http://timeoutbengaluru.net/aroundtown/aroundtown_feature_details.asp?code=59).
- [73] Helder Solari. personal communication, 2010.
- [74] The International Charter Space and Major Disasters. The international charter space and major disasters. [www.disasterscharter.org](http://www.disasterscharter.org), 2010.
- [75] S. Tuominen and M. Haakana. Landsat TM imagery and high altitude aerial photographs in estimation of forest characteristics. *Silva Fennica*, 39(4):573, 2005.
- [76] UN-HABITAT. Slums of the World: The face of urban poverty in the new millennium? <http://www.unhabitat.org/pmss/listItemDetails.aspx?publicationID=1124>, 2003.
- [77] UN-HABITAT. The Challenge of Slums: Global Report on Human Settlements 2003. <http://www.unhabitat.org/pmss/listItemDetails.aspx?publicationID=1156>, 2003.
- [78] UN-HABITAT. Expert meeting on slum identification mapping and monitoring. <http://www.unhabitat.org/content.asp?cid=5714&catid=5&typeid=6&subMenuId=0>, 2008.
- [79] UN-SPIDER Knowledge Portal. <http://www.un-spider.org/>.
- [80] L.A. Vierling, M. Fersdahl, X. Chen, Z. Li, and P. Zimmerman. The Short Wave Aerostat-Mounted Imager (SWAMI): A novel platform for acquiring remotely sensed data from a tethered balloon. *Remote Sensing of Environment*, 103(3):255–264, 2006.
- [81] Composition of a typical OpenStreetMap API response. <http://unterbahn.com/2009/10/composition-of-a-openstreetmap-api-responses/>.
- [82] Rectify Map San Ignacio Loyola on Map Warper, Project Website. <http://warper.geothings.net/maps/preview/2018>.

- [83] OpenStreetMap project imports US government maps. <http://www.linux.com/archive/feature/119493>.
- [84] Projective Texturing with Canvas — Steven Wittens - Acko.net, Project Website. <http://acko.net/blog/projective-texturing-with-canvas>.
- [85] Eric B. Wolf. Low-cost large scale aerial photography and the upland south folk cemetery. Master's thesis, Northwest Missouri State University, 2006.
- [86] Dennis Wood and John Fells. *The Power of Maps*. Guilford Press, 1992.
- [87] Virginia Zavala and Nino Bariola. Enra kopiai, non kopiai: Gender, ethnicity and language use in a Shipibo community in Lima. In Mercedes Nio-Murcia and Jason Rothman, editors, *Bilingualism and identity: Spanish at the crossroads with other languages*, pages 151–174. John Benjamins Publishing Company, 2008.

# Acronyms

**API** Application Programmer's Interface

**BAP** Balloon Aerial Photography

**CEDRO** Centro de Información y Educación para la Prevencinó del Abuso de Drogas

**CHDK** Canon Hacker Development Kit

**COFOPRI** Organization for the Formalization of Informal Property

**EXIF** Exchangeable Image File Format

**GDAL** Geospatial Data Abstraction Library

**GeoTIFF** Geographic TIFF

**GIS** Geographic Information Systems

**GSS** Geographic Stylesheets

**HOT** Humanitarian OpenStreetMap Team

**JOSM** Java OpenStreetMap Editor

**KAP** Kite Aerial Photography

**KML** Keyhole Markup Language

**LABB** Louisiana Bucket Brigade

**MODIS** Moderate Resolution Imaging Spectroradiometer

**NOAA** National Oceanic and Atmospheric Administration

**OMC** OpenMapsCaucasus

**PGIS** Participatory GIS, sometimes known as PPGIS or Public Participation GIS

**SIPRI** Stockholm International Peace Research Institute

**SVG** Scalable Vector Graphics

**TIFF** Tiled Image File Format

**TMS** Tiled Map Service

**WMS** Web Map Service



# License

This work is licensed under the Creative Commons Attribution 3.0 Unported License. To view a copy of this license, visit <http://creativecommons.org/licenses/by/3.0/> or send a letter to Creative Commons, 171 Second Street, Suite 300, San Francisco, California, 94105, USA.