

# EUROPEAN ORGANIZATION FOR NUCLEAR RESEARCH

## CERN - AB Department

CERN-AB-2007-059

CLIC Note -720

### HIGH RF POWER PRODUCTION FOR CLIC

I. Syrathev, D. Schulte, E. Adli, M. Taborelli

CERN, Geneva, Switzerland

#### Abstract

The CLIC Power Extraction and Transfer Structure (PETS) is a passive microwave device in which bunches of the drive beam interact with the impedance of the periodically loaded waveguide and excite preferentially the synchronous mode. The RF power produced (several hundred MW) is collected at the downstream end of the structure by means of the Power Extractor and delivered to the main linac structure. The PETS geometry is a result of multiple compromises between beam stability and main linac RF power needs. Another requirement is to provide local RF power termination in case of accelerating structure failure (ON/OFF capability). Surface electric and magnetic fields, power extraction method, HOM damping, ON/OFF capability and fabrication technology were all evaluated to provide a reliable design.

Presented at  
PAC07, 22nd PAC Conference, June 25-29, 2007, Albuquerque, USA

*Geneva, Switzerland  
August 2007*

# HIGH RF POWER PRODUCTION FOR CLIC

I. Syrathev, D. Schulte, E. Adli, M. Taborelli, CERN, Geneva, Switzerland.

## Abstract

The CLIC Power Extraction and Transfer Structure (PETS) is a passive microwave device in which bunches of the drive beam interact with the impedance of the periodically loaded waveguide and excite preferentially the synchronous mode. The RF power produced (several hundred MW) is collected at the downstream end of the structure by means of the Power Extractor and delivered to the main linac structure. The PETS geometry is a result of multiple compromises between beam stability and main linac RF power needs. Another requirement is to provide local RF power termination in case of accelerating structure failure (ON/OFF capability). Surface electric and magnetic fields, power extraction method, HOM damping, ON/OFF capability and fabrication technology were all evaluated to provide a reliable design.

## INTRODUCTION

The CLIC PETS is one of the key components in the CLIC two-beam acceleration scheme [1]. In general, the decelerating module, consisting of PETS, quadrupoles and high power RF networks, must not be longer than the accelerating structure it drives, to ensure maximum effective gradient. The PETS should deal with high current electron beams ( $\sim 100$  A) and thus should provide extremely stable beam transportation for a few hundred meters. In the presence of deceleration, the final energy spread in a drive beam of  $\sim 90\%$  is needed in order to achieve high efficiency of the RF power production; therefore, strong FODO lattice and strong damping of any deflecting HOM in the PETS are required to prevent significant beam losses [2].

The basic CLIC parameters were drastically changed recently [3, 4]. The major modifications concerned the operating frequency and the accelerating gradient in the main linac. Both the operating frequency and the accelerating gradient were reduced. The new operating frequency of 12 GHz (cf. 30 GHz) and the accelerating gradient of 100 MV/m (cf. 150 MV/m) were adopted after a thorough study.

These modifications required a complete revision of the whole CLIC scheme. In this paper, the new X-band version of the CLIC RF power generating structure is presented.

## RF POWER GENERATION IN PETS

The new layout of the CLIC module is shown in Fig. 1. In this layout, the single PETS should produce RF power for two accelerating structures. The length of the module is driven by the physical length of the accelerating structure. The module, in itself, consists of the two focusing quadrupoles and four PETS connected to the eight

accelerating structures. The new CLIC decelerator sector parameters are listed in Table 1.

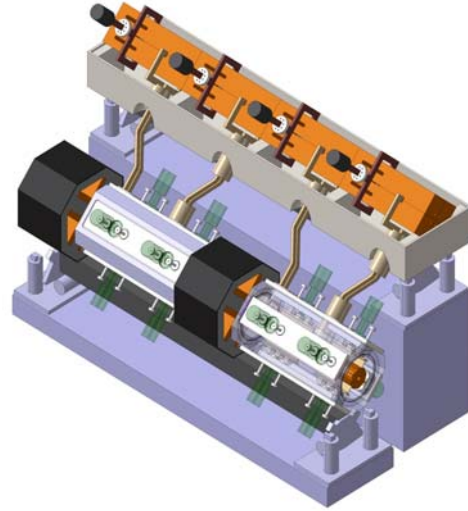

Figure 1: The CLIC module layout

Table 1: The X-band CLIC decelerator parameters

Number of sectors/linac	26
Sector length, m	810
Number of PETS/sector	1376
Drive beam energy, GeV	2.4
Drive beam current, A	93.3

The RF power generated by the bunched beam in a constant impedance periodic structure in general can be expressed as:

$$P = I^2 L^2 F_b^2 \omega_0 \frac{R/Q}{V_g 4} \quad (1),$$

where  $I$  is the beam current,  $L$  – the active length of the structure,  $F_b$  – the single bunch form factor,  $\omega_0$  – the bunch frequency,  $R/Q$  – the impedance per meter length,  $Q$  – the quality factor and  $V_g$  – the group velocity. At a given frequency and with fixed RF power and beam current, the only free parameters are the structure length and structure aperture. In our case, the PETS active length is limited by the module layout and thus the structure aperture absolute upper limit is well defined (impedance  $\sim 1/a^2$ ). The lower limit for the structure aperture is governed by the RF constraints [5]. In a simple way it can be written as:  $a_{PETS} \geq a_{as} \times n_s$ , where  $a_{as}$  is the input aperture of the accelerating structure and  $n_s$  is the number of accelerating structures fed by the single PETS. In addition, the choice of the aperture defines the power extraction strategy, which in turn, can influence the active

length. As a result of multiple compromises the PETS aperture with  $a/\lambda=0.46$  was chosen, see Table 2.

Table 1: The X-band CLIC PETS parameters

Aperture, mm	23
Phase advance/cell, degrees	90
R/Q, Ohm/m	2290
$\beta=V_g/c$	0.453
Q-factor	7200
Active length, m	0.231 (37 cells)
RF pulse length, ns	290
RF power, MW	138

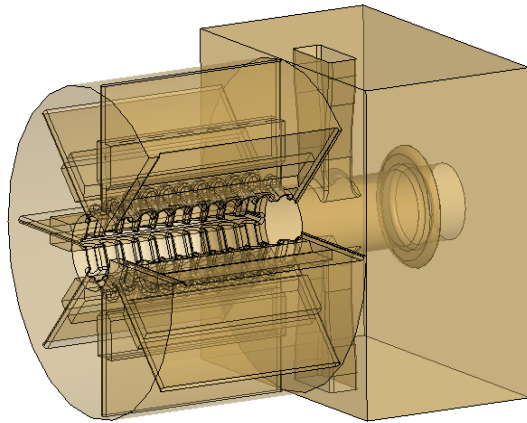

Figure 2: The CLIC PETS general view

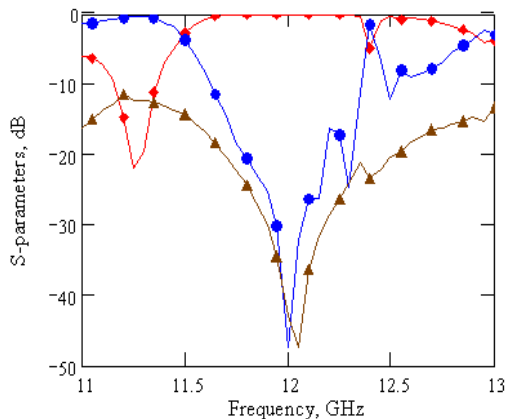

Figure 3: The PETS S-parameters, diamonds - transmission, circles - reflection and triangles - isolation.

In its final configuration, PETS comprises eight octants separated by the damping slots. Each of the slots is equipped with HOM damping loads. This arrangement follows the need to provide strong damping of the transverse modes. In periodic structures with high group velocities, the frequency of a dangerous transverse mode is rather close to the operating one. The only way to damp

it is to use its symmetry properties. To do this, only longitudinal slots can be used. These slots also naturally provide high vacuum conductivity for the structure pumping. The upstream end of the PETS is equipped with a special matching cell and the output coupler [6], see Fig. 2. The simulated efficiency of the power extraction from PETS is above 99%, see S-parameters simulated with HFSS [7] in Fig.3.

Throughout the PETS design, special care was taken to reduce the surface field concentration in the presence of the damping slots. This was done using special profiling of the iris, see Fig. 4. Compared to the structure with the circular symmetry, a field enhancement of only 20% was achieved. The maximum surface electric field for the nominal RF power is 48 MV/m.

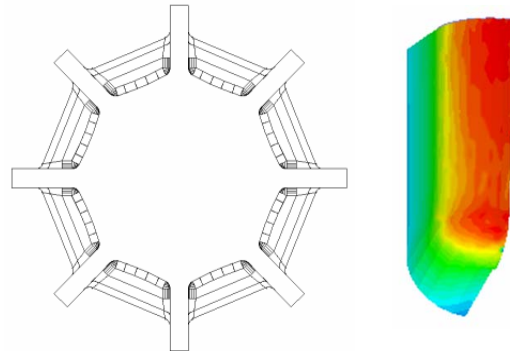

Figure 4: The PETS cross-section and electric field plot on the iris tip (one quarter of the iris is shown).

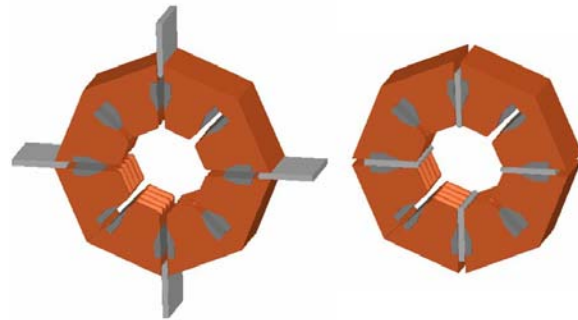

Figure 5: PETS ON (left) and OFF (right) configurations with detuning wedges.

During machine operation, it will be necessary to locally turn the RF power production OFF when either PETS or an accelerating structure fails due to breakdown. The net RF power generated by the beam at the end of the constant impedance structure will be zero if the structure synchronous frequency is detuned by amount  $\pm\beta c/(1-\beta)L$ , where  $\beta = V_g/c$  and  $L$  - length of the structure, see [8] for more details. We have found that such a strong detuning can be achieved by inserting four thin wedges through four of the eight damping slots, see Fig. 5. The wedge geometry and the final wedge position are optimised in such a way that at any intermediate wedge position, there is no electrical field enhancement in the gap between the wedge and the wall; thus, the device can operate as a variable attenuator.

## HOM DAMPING AND BEAM STABILITY

In the case of a structure with a high group velocity ( $\beta=V_g/c$ ) and finite length ( $L$ ), the expression for the wake potential [9] should be evaluated:

$$W(z) = 2q \times K \sin\left(\frac{\omega z}{c}\right) e^{-\frac{\omega z}{2Q(1-\beta)c}} \times \left\{ 1 - \frac{\beta z}{L(1-\beta)} \right\}$$

$$W(z) = 0, \quad z > L \frac{1-\beta}{\beta} \quad (2),$$

here we have included the catch-up parameter for damping and drain out from the structure of the finite length. Following (2), the best scenario to provide the fast decay of the wakefields is to reduce the Q-factor and to increase the group velocity as much as possible.

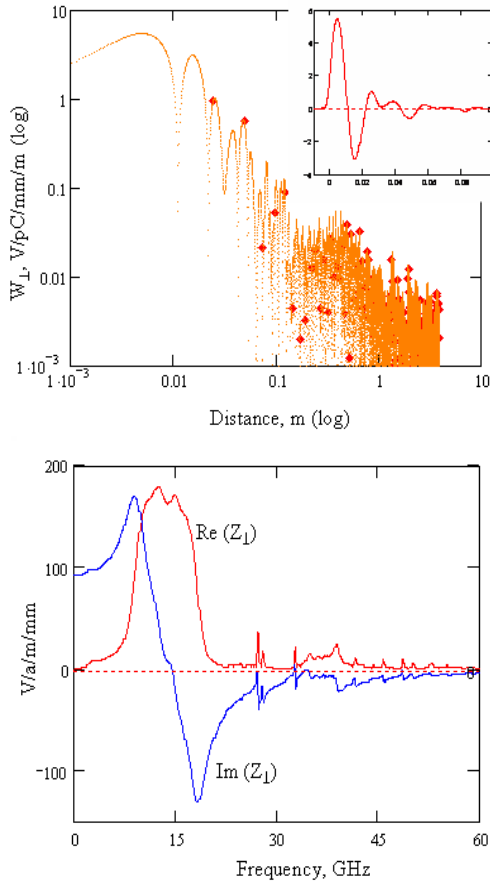

Figure 6: The transverse wake potential (upper plot) and impedance (lower plot) simulated with GDFIDL for the complete PETS geometry.

In the presence of the longitudinal slots, the transverse mode field pattern is dramatically distorted so that a considerable amount of the energy is now stored in the slots. The new, TEM-like nature of the mode significantly increases the group velocity, in our case from  $0.42c$  to almost  $0.7c$ . With introduction of the lossy dielectric material close to the slot opening, the situation improves further. The proper choice of the load configuration with respect to the material properties makes it possible to

couple the slot mode to a number of the heavily loaded modes in dielectric. This gives a tool to construct the broad wakefields impedance. The transverse wakepotential simulations in a complete PETS geometry were done with GDFIDL [10], see Fig. 6. The computer code PLACET [11] was then used to analyze the beam dynamic along the decelerator in the presence of strong deceleration and calculated wakefields. The results of the simulation (see Fig. 7) clearly indicate that the suppression of the transverse wakefields obtained, is strong enough to guarantee the beam transportation without losses.

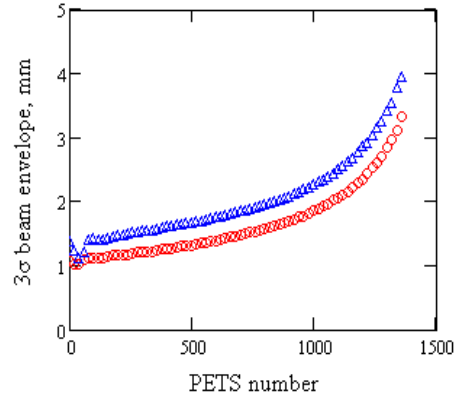

Figure 7: Evolution of the  $3\sigma$  beam envelope along the decelerator sector; circles – without wakefields, triangles – with wakefields included.

## REFERENCES

- [1] H.H. Braun et al., Updated CLIC parameters 2005, CLIC-Note-627 - Geneva, CERN, 12 May 2006.
- [2] D. Schulte, Stability of the drive beam in the decelerator of CLIC, CLIC-Note-528 – Geneva, CERN, 25 Jul 2002.
- [3] R. Corsini, Results on CLIC Proof of Principle from CTF3, this Conference.
- [4] CLIC DRAFT PARAMETER LIST 2007. <http://clic-meeting.web.cern.ch/clic-meeting/clictable2007.html>
- [5] W. Wuensch, Progress in Understanding the High-Gradient Limitations of Accelerating Structures, CLIC-Note-706 - Geneva, CERN, 08 Mar 2007.
- [6] I. Syratchev, Mode Launcher as an Alternative Approach to the Cavity-Based RF Coupler of Periodic Structures, CLIC-Note-503 – Geneva, CERN, 17 Jan 2002.
- [7] Ansoft Corporation - HFSS. <http://www.ansoft.com/>
- [8] I. Syratchev, 30 GHz High Power Production for CLIC, 7<sup>th</sup> Workshop on High Energy Density and High Power RF, Kalamata, Greece, 13-17 June 2005.
- [9] P.B. Wilson, Introduction to Wakefields and Wake Potentials, SLAC-PUB-4547, 1989
- [10] The Gdfidl Electromagnetic Field simulator. <http://www.gdfidl.de/>
- [11] D. Schulte et al. Simulation Package based on PLACET, Proceedings of the 2001 Particle Accelerator Conference, Chicago, pp. 3033-3035.