

# AIR POLLUTION INDEX (API) REAL TIME MONITORING SYSTEM

NORHAFIZAH BINTI RUSLAN

A thesis submitted in partial fulfilment of the requirements for the award of  
Degree of Master of Electrical Engineering

Fakulti Kejuruteraan Elektrik Dan Elektronik  
Universiti Tun Hussein Onn Malaysia

JANUARY 2015

## **ABSTRACT**

This project is to develop a low cost, mobile Air Pollutant Index (API) Monitoring System, which consists of Sharp GP2Y1010AU0F optical dust detector as a sensor for dust, Arduino Uno and LCD Keypad Shield. A signal conditioner has been used to amplify and extend the range of the sensor reading for a more accurate result. Readings from the sensor has been compared with reference data from the Department of Environment, Malaysia to ensure the results validity of the developed system. The developed dust detector is expected to provide a relatively accurate API reading and suitable to be used for the detection and monitoring of dust concentrations for industrial areas around Parit Raja, Johor.

## **ABSTRAK**

Projek ini adalah untuk membangunkan alat mudah alih berkos rendah, Indeks Pencemaran mudah alih Udara (IPU) Sistem Pemantauan, yang terdiri daripada Sharp GP2Y1010AU0F pengesan debu optik sebagai sensor bagi habuk, Arduino Uno dan LCD Keypad Shield. Satu penyaman isyarat akan digunakan untuk menguatkan dan melanjutkan pelbagai bacaan sensor untuk keputusan yang lebih tepat. Bacaan dari sensor akan dibandingkan dengan data rujukan daripada Jabatan Alam Sekitar, Malaysia bagi memastikan kesahihan keputusan yang sistem yang dibangunkan. Pengesan debu dibangunkan dijangka menyelesaikan masalah-masalah projek ini dan sesuai digunakan untuk mengesan dan memantau kepekatan debu bagi kawasan perindustrian di seluruh Parit Raja, Johor.

## TABLE OF CONTENTS

	<b>TITLE</b>	<b>i</b>
	<b>DECLARATION</b>	<b>ii</b>
	<b>DEDICATION</b>	<b>iii</b>
	<b>ACKNOWLEDGEMENT</b>	<b>iv</b>
	<b>ABSTRACT</b>	<b>v</b>
	<b>ABSTRAK</b>	<b>vi</b>
	<b>TABLE OF CONTENTS</b>	<b>vii</b>
	<b>LIST OF TABLES</b>	<b>x</b>
	<b>LIST OF FIGURES</b>	<b>xi</b>
	<b>LIST OF SYMBOLS AND ABBREVIATION</b>	<b>xiii</b>
	<b>LIST OF APPENDICES</b>	<b>xiv</b>
<b>CHAPTER 1</b>	<b>INTRODUCTION</b>	<b>1</b>
	1.1 Introduction	1
	1.2 Air Pollution	1
	1.2.1 Classification of Air Pollutions	2
	1.2.2 Air Pollution Index (API)	2
	1.2.3 Measurement of Air Quality	3
	1.3 Problem Statement	3
	1.4 Objectives	4
	1.5 Scope of Project	4

<b>CHAPTER 2</b>	<b>LITERATURE REVIEW</b>	<b>5</b>
2.1	Introduction	5
2.2	Measurement Principles for Dust Detection	5
2.3	Optical Dust Measurement	6
2.4	Related Studies	7
2.5	Summary of Related Studies	10
<b>CHAPTER 3</b>	<b>METHODOLOGY</b>	<b>11</b>
3.1	Introduction	11
3.2	The Development of Flow Chart	11
3.3	System Design	13
3.4	Hardware Development	14
	3.4.1 Hardware Selection and Development Platform	14
	3.4.2 Air Particle Optical Sensor	15
	3.4.3 LCD Keypad Shield	16
3.5	Software Development	17
	3.5.1 Software Selection	17
<b>CHAPTER 4</b>	<b>RESULT AND ANALYSIS</b>	<b>19</b>
4.1	Introduction	19
4.2	Hardware Design	19
4.3	Arduino Program	22
4.4	Data Sampling	25
4.5	Results of Dust Density using Sharp Optical Dust Sensor	29
4.6	Conclusion	36

<b>CHAPTER 5</b>	<b>CONCLUSION</b>	<b>37</b>
5.1	Introduction	37
5.2	Recommendation and Future Works	38
	<b>REFERENCES</b>	<b>39</b>
	<b>APPENDICES</b>	<b>42</b>

## LIST OF TABLES

1.1	API System Adopted in Malaysia	3
2.1	Comparison of Related Projects	10
4.1	Pins Assignments	20
4.2	Proposed Sampling Point and Expected Results	29
4.3	Real-time Data Reading for Sampling Point 1	30
4.4	Real-time Data Reading for Sampling Point 2	31
4.5	Real-time Data Reading for Sampling Point 3	32
4.6	Real-time Data Reading for Sampling Point 4	33
4.7	Real-time Data Reading for Sampling Point 5	34
4.8	Average Data of Dust Measurement Collection	35
4.9	Comparable Data between Two Sources	35

## LIST OF FIGURES

2.1	Operation of Optical Dust Measurement	6
2.2	Schematic Diagram of the Dust Concentration Measuring Principle	7
3.1	Methodology Flowchart	12
3.2	Block Diagram of API Monitoring System	13
3.3	Arduino Uno	14
3.4	Output Voltage versus Dust Density	15
3.5	Parameter of Optical Sensor	16
3.6	LCD Keypad Shield	17
3.7	Arduino IDE	17
4.1	Connection Six Pins on Sensor	20
4.2	Pin Colouring Wire on the Sensor	21
4.3	Official Schema from Sharp	21
4.4	Connection between Arduino and Sensor	22
4.5	Done Compiling	23
4.6	Compiling Sketch	23
4.7	Done Uploading	24
4.8	LCD Display Code	24
4.9	Data Collection from Sensor	25
4.10	Example of Application of the Particle Sensor	26
4.11	Location of Portable Air Quality Monitoring	27
4.12	Location 1 of Sharp GP2Y1010AU0F Optical Dust Sensor	27
4.13	Location 2 of Sharp GP2Y1010AU0F Optical Dust Sensor	28
4.14	Location 3 of Sharp GP2Y1010AU0F Optical Dust Sensor	28
4.15	Location 4 of Sharp GP2Y1010AU0F Optical Dust Sensor	28
4.16	Location 5 of Sharp GP2Y1010AU0F Optical Dust Sensor	29
4.17	Sample Point 1 Real Time Dust Measurement	30



4.18	Sample Point 2 Real Time Dust Measurement	31
4.19	Sample Point 3 Real Time Dust Measurement	32
4.20	Sample Point 4 Real Time Dust Measurement	33
4.21	Sample Point 5 Real Time Dust Measurement	34
4.22	Linear Range of the Sharp Sensor	35

## LIST OF SYMBOLS AND ABBREVIATION

API	-	Air Pollutant Index
CO	-	Carbon Monoxide
NO <sub>x</sub>	-	Nitrogen Oxides
SO <sub>x</sub>	-	Sulphur Oxides
PM	-	Particulate Matter
O <sub>3</sub>	-	Ozone
TSP	-	Total Suspended Particles
PSI	-	Pollutant Standard Index
MAQI	-	Malaysian Air Quality Index
EPA	-	United States Environmental Agency
LCD	-	Liquid Crystal Display
PD	-	Photodiode
PDA	-	Personal Digital Assistant
PLX DAQ	-	Parallax Microcontroller Acquisition to Excell
IDE	-	Integrated Development Environment
VO	-	Output Voltage
KKTDI	-	Kolej Kediaman Tun Dr Ismail
DOE	-	Department of Environment
$I_0$	-	Initial Intensity
$I$	-	Resulting Intensity of the Light Beam
$l$	-	Integrated Circuit
$\epsilon$	-	Distance
$c$	-	Dust Concentration

**LIST OF APPENDICES**

A	Gantt chart for Master Project 1	42
B	Gantt chart for Master Project 2	43
C	Application Note for Sharp Dust Sensor GP2Y1010AU0F	44
D	Coding for Arduino	51
E	Raw Data from Sharp Sensor	53
F	Laporan Pemantauan Kualiti Udara	61

## **CHAPTER 1**

### **INTRODUCTION**

#### **1.1 Introduction**

Air pollution is regarded as the pollution that has the greatest impact on the environment. Global warming phenomena that threaten our earth in recent years is closely related to the level of air pollution that caused by vast amount of carbon emission from vehicle petrol and diesel combustion, waste from ever-expanding production industry, uncontrolled combustion of fossil fuel and open-air burning in the waste management site. Hence, air pollution gradually becomes the focus of the world to address. Apart from the man-made causes, natural phenomena also contribute to air pollution, such as forest fires caused by heat from the sun and volcanic eruption capable bursting out a huge amount of particles, smoke and dust with large amounts of visual impairment in the vicinity of the incident.

#### **1.2 Air Pollution**

Ministry of Natural Resources and Environment stated that there are many sources of air pollutions in Malaysia such as from industries, development activities, motor vehicles, power generation, land clearing and open burning and forest fires. Wisconsin Department of Natural Resources mentions that the specific pollutant, its

concentration in the air, the length of time of exposure, human own health conditions and the environmental quality of the area are all factors in how air pollution affects human's health [1].

### **1.2.1 Classification of Air Pollutions**

There are six standards of air pollutants which are Carbon Monoxide (CO), lead sources, Nitrogen Oxides (NO<sub>x</sub>), Sulphur Oxides (SO<sub>x</sub>), Particulate Matters (PM), Ozone (O<sub>3</sub>) and Total Suspended Particles (TSP). Carbon monoxide with its characteristics is a colorless, odorless and tasteless gas. In calm weather especially during winter and early spring, the concentration might accumulate at the harmful levels in the interim due to the fuel combustion reaches a peak. Sources of carbon monoxide includes automobile emissions, home or building heating, forest fires, vegetation during growth stages and a chemical transformation of methane [2].

### **1.2.2 Air Pollution Index (API)**

The API is an index for reporting daily air quality. Air pollution index normally includes the major air pollutants that could hard to human health. API provides understandable information about the air pollution to the public. Malaysian Air Quality Index (MAQI) follows closely to Pollutant Standard Index (PSI) develop by United States Environmental Agency (EPA). The air pollutant included in Malaysia's API are carbon monoxide (CO), nitrogen dioxide (NO<sub>2</sub>), sulphur dioxide (SO<sub>2</sub>), ozone (O<sub>3</sub>) and suspended particulate matter less than 10 microns in size (PM<sub>10</sub>) [3].

Table 1.1: API system adopted in Malaysia

Air Pollutant Index	Level of Health Concern	Colours
0 to 50	Good	Blue
51 to 100	Moderate	Green
101 to 200	Unhealthy	Yellow
201 to 300	Very Unhealthy	Orange
301 and above	Hazardous	Red

### 1.2.3 Measurement of Air Quality

In recent years, a few methods have been applied by researchers in order to measure the level of air pollutions. The activity of air pollution monitoring are typically divert into two classifications: source monitoring and ambient air monitoring. A direct approach of monitoring can be done using continuous measurement instrumentation or manual methods or remotely optical sensing systems. For the first type, source monitoring considers the measurement of emissions directly from a fixed or mobile emission source, normally in a close or contains duct, vent, stack or chimney. Stationary source data is used to determine control technology performance, to confirm established permission limits are being met and as an input to ozone and/or health risk prediction models. Ambient air monitoring however involves the depth occurrence of specific pollutants presents in an immediate surrounding atmosphere. Ambient air monitoring used by major urban stations often deploys several instruments which specifically dedicated to measuring specific target pollutants [4].

### 1.3 Problem Statement

Air pollution index or API is basically a scale to gauge the severity or how polluted the air is. The greater number of the API represents the more dangerous the air quality to human health. Hot and dry season that occurred in our country in recent

months has exposed our environment towards to a lot of disaster especially the fire. Fires in either remote or urban area could cause another disaster which is called haze. Haze will definitely affect air pollution index in the particular area where the fire occur. On the other hand, industrial waste such as unreacted gas could also affect the air pollution index especially the area nearby the industrial area.

API value is very important for all residents to minimize outdoor activities because a high air pollution level indicates a very bad air quality to human. However, most of the existing API measurement systems are relatively massive in size and the price is prohibitive. In order to provide us with real time level of API reading in certain area, this project has been proposed, which is small hence portable and relatively cheap as it is based on Arduino microcontroller.

#### **1.4 Objectives**

The main objectives of this project are:

- i. To design and develop a low cost portable pollutant index (API) monitoring system in real time that combined sensors, Arduino and LCD.
- ii. To develop a portable API acquisition device that is easy to carry and light.
- iii. To examine the performance of the developed system through experiments and testing.

#### **1.5 Scope of Project**

This project will be focusing on the level of API in environments especially nearby the factory area. Reading of the air quality will consist of the level of air particle such as dust material which will be detected by the sensor being placed in various places. The scope of this project will also focus on the study of optical sensor. In order to monitor the air quality of the study area, the most reasonable way of detecting and monitoring dust level are being studied among its various functions and capabilities.

## **CHAPTER 2**

### **LITERATURE REVIEW**

#### **2.1 Introduction**

This chapter discusses the literature review from previous researches that are related to this project. The previous projects give some ideas and understanding on several previous projects. There are previous researches that have been done on detecting and monitoring the air quality either indoor or outdoor using various methods and discussed here.

#### **2.2 Measurement Principles for Dust Detection**

The common measurement principles for dust detection including Gravimetric measurement, Triboelectric measurement and Optical measurement. The gravimetric principle is the method used in analytical chemistry for quantitative determination of analysis based on the mass of a solid. [5] It is suitable to measure concentration of dust in liquids. The Triboelectric measurement is another measurement of dust concentration that contact electrification of certain material become electrically charged after they come into contact with another different material and are then



separated. This principle can be applied in the measurement of dust for ceramic, bags, and cartridge filters or cyclones where indicative monitoring is required. The optical measurement of dust based on the attenuation of the intensity of a light beam by absorption and dispersion penetrating a cloud with solid particle [6].

### 2.3 Optical Dust Measurement

Dust sensor using optical measurement principle is usually used in continuous measurement of medium and high dust concentration on industrial plant and also for monitoring limited values. It is also able to use to investigate the level of dust in saturated gas downstream of desulfurization plants, downstream of wet scrubbing plants and wet exhaust gas [5]. Figure 2.1 shows the concept of the operation of optical dust measurement. An infrared emitting diode and a phototransistor are diagonally arranged. Light reflects on the particles passing through the whole are picked up by the photodiode (PD) is transformed into voltage. The voltage has to be amplified to be able to read the change.

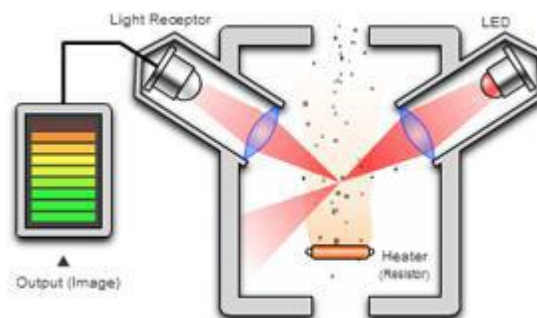

Figure 2.1: Operation of Optical Dust Measurement

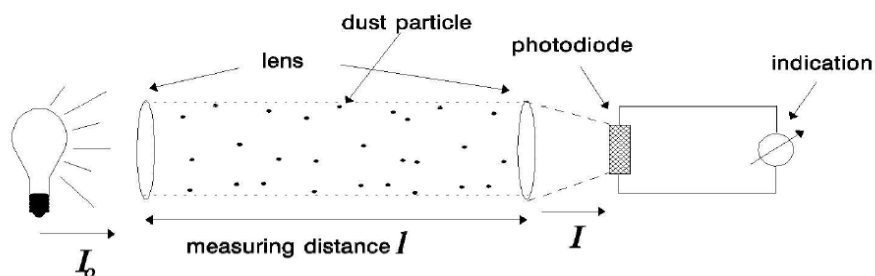

Figure 2.2: Schematic Diagram of The Dust Concentration Measuring Principle

Figure 2.2 shows the schematic diagram of the dust concentration measuring principle. Lambert-Beer's law in equation (2.1) describes the relation between the light transmission and the dust concentration,  $c$  according to the following equation:

$$I = I_0 e^{-\epsilon c l} \quad (2.1)$$

Where:

$I_0$  = Initial Intensity

$I$  = resulting intensity of the light beam

$\epsilon$  = Coefficient of extinction (a specific constant for the dust type and the appliance)

$l$  = distance

$c$  = dust concentration

## 2.4 Related Studies

Sung, J.O and Wan, Y.C [6] had developed a RF wireless sensor module with optimal communication condition to monitor indoor air quality in a room or office. The monitoring work can be done by web-based monitoring system together with other home networking system by using PDA (Personal Digital Assistant). There are several sensors for instance; temperature sensor, humidity sensor, Carbon Dioxide

sensor and flying dust sensor were built in the RF transmitter board for monitoring the room environment. An Intel 8051 microcomputer was used to control the power switches of consumer electronics through signals received from PC or PDA.

Kim and Paulos [7] had designed and implemented a system called inAir that able to measure, visualize, and share indoor air quality. A DC 1100 air quality is used to measure the level of indoor pollutant, an AVR-based Arduino which transplanted inside the air quality monitor, and an iPod Touch is used to process, visualize and transmit the data wireless to the Arduino. The data will be reported every 15 seconds at the same time the Arduino will encode the data into a series of audio tones like a modem and will be read by iPod Touch via microphone port. The data can be shared from central server in real-time by using Wi-Fi networking.

Phang [8] developed a room dust monitoring system in which the main objective was to monitor the dust concentration of a room and show the readings on a personal computer in real time. These systems used an Arduino Uno controller work based on a Shinyei PPD20V particle sensor to measure the dust concentration in a room. The readings taken from the sensor will be send to computer to show in real time using Graphical User Interfacing (GUI) by using Visual Basic program. The result was taken in several conditions including clean room, dusty room, room with cooking haze and room with cigarette smoke. The result varied with the condition of the room. With this device, the awareness of the effects of human activities on indoor pollutants can be rose up and thus lead to human health and well-being.

Ab Rahman [9] presented an Air Quality Monitoring System and Controller by using TGS 2600 dust sensor. In this project, the concentration of the dust displayed on the LCD which was programmed with MPLAB using PIC16F877A. The LED displays the condition of dust concentration. Green light represents “normal” condition, which the concentration of the dust is from 0-100ppm. Yellow colour means “care” condition where the dust concentration is from 101-200ppm and while the dust concentration is from 201ppm and above, it present “danger” condition and red light will on. The buzzer will beep when the dust concentration achieved “danger” condition.

Taharim [10] developed the usage of multiple sensor and zigbee modules was used to display more accurate and scientific values of temperature, humidity and moisture. This system operated based on surrounding condition of air and soil. It is capable to measure the value of temperature, relative humidity in the air and

percentage of moisture in the soil. The unit for temperature is degree Celsius, unit for humidity is the percentage of relative humidity and unit for moisture is percentage. The measured values are converted into digital signal via Arduino Uno and transmitted using Zigbee module as the medium. For this project, it consists of one transmitter and one receiver. All those value are displayed in the computer screen using Visual BASIC software for easier references. These systems allow a simple, efficient and accurate surround monitoring system.

According to Zakaria [11] had designed a low cost sensor for a Rice Mill Factory located in Pering, Kedah Darul Aman. The factory needs to provide a good air quality surrounding not only for its employee but also for the neighbouring villagers. A 24 hours production time also contributed to its pollution factor and the level of exposure endured by the employee during the work shift needs to be considered as well. Rice Husk/Dust Air Particle Sensor using ZigBee Wireless Sensor Network was developed using SHARP GP2Y1010AU0F optical dust sensor as the measurement tools, an Arduino Fio board was used as the development board for its expansion capabilities using ZigBee Wireless Modules. A point to point approached was developed with the data being transmitted back to its host computer, and a serial port was used to read the HEX string data. Parallax Microcontroller Acquisition to Excel (PLX DAQ) software is used to read the string data and save it to Microsoft Excel software. Using Visual Basic Application on Microsoft Excel, a graph displaying the dust measurement can be viewed on the real time basis. Conclusively, the sensor and methods used for this project was substantial enough to monitor the dust density for reducing the dust pollution in the Rice Mill Factory.

All of the past projects successfully created a system which could monitor the reading of the air quality within their operating environment either through the usage of dust sensor or particle sensor. The readings then were transferred to their very own output system through various medium including wireless technology to create a great input and output air monitoring system that not just monitor the air quality but display the results and analysis in real time basis as well. Being a real time system really did make the system more practical to be applied in our life as the value of air quality could be affected by many factors. Taking accuracy, precision and real time monitoring into account, a well-built system could be produced to tackle various problems related to air quality in our daily life.

## 2.5 Summary of Related Studies

Table 2.1 shows the comparison of related project that has been researched in order to implement API monitoring system.

Table 2.1: Comparison of Related Projects

No.	Title of Project	Description	Advantages	Disadvantages
1.	Room Environment Monitoring System form PDA Terminal	-control by PDA terminal -RF wireless sensor module	-Easily replaced	-Difficult to control more than one sensor
2.	InAir: Sharing Indoor Air Quality Measurements and Visualization	-Arduino -Ipod Touch	-Increased awareness of, and reflection on air quality	-Limited for indoor
3.	Room Dust Monitoring System	-Shinyei PPD 20V particle sensor -Visual Basic	-Detected condition of the room	- Limited area
4.	<i>Rekabentuk dan Pembangunan Sistem Pemantauan Kualiti Udara dan Penggera</i>	-TGS 2600 -PIC16F877A	-Display the condition of dust concentration which is normal, care and danger	-Program memory is not accessible
5.	Plantation Monitoring System using Multiple Sensor and Arduino Uno	-Multiple sensor -Arduino -Zigbee Modules	-Capable to measure the value of temperature, relative humidity in the air and percentage of moisture in the soil	-Wired cable and sensor are not practical used
6.	Rice Husk/Dust Air Particle Sensor using Zigbee Wireless Sensor Network	-Optical dust sensor (Sharp) -Zigbee Module	-Practical -Low cost	-only limited for measuring the respirable dust in a Rice Mill factory to maintain its good air quality policy

## **CHAPTER 3**

### **METHODOLOGY**

#### **3.1 Introduction**

This chapter explains the methodology of the project in which a set of activities are implemented in completing the project successfully. Each activity involved in the project is discussed briefly with appropriate illustration. As a result, this project comes out with hardware and software that have been developed systematically based on the defined methodology.

#### **3.2 The Development of Flow Chart**

Figure 3.1 shows the methodology flowchart during the progress in completing the API Monitoring System.

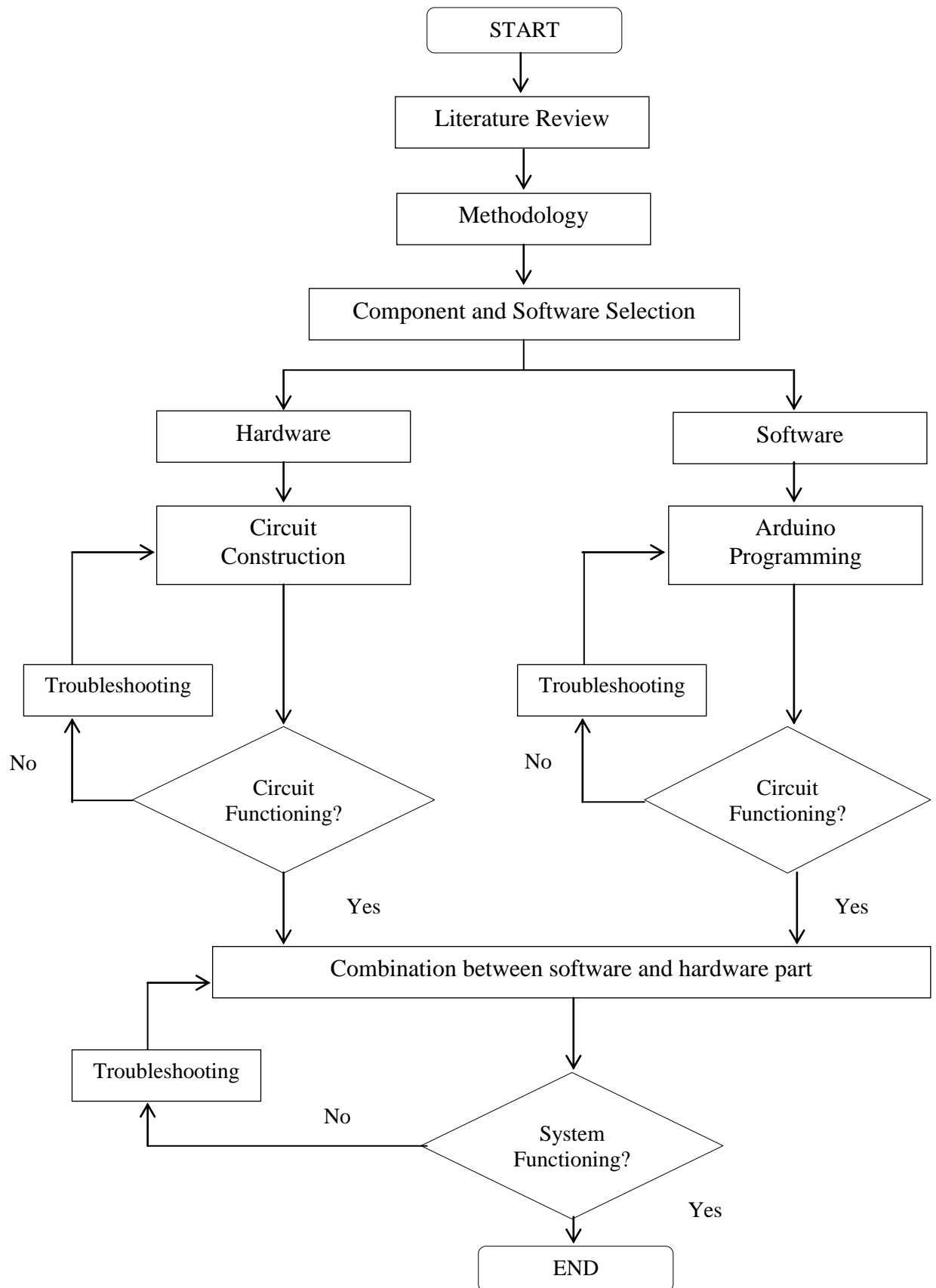

Figure 3.1: Methodology Flowchart

In this chapter, the progress of designing an API Monitoring System will be discussed in detail. Therefore, this chapter deals with the actual design and construction of the system. The system can be categorized into two parts as below:

- i. Hardware development part
- ii. Software development part

### 3.3 System Design

An API monitoring system will be designed and implemented to measure, visualize and share indoor or outdoor air quality. The prototype consists of a few main components that function together as a system; a sensor to measure air quality, a processor to gather the measure data and a platform to manage the gathered data.

Figure 3.2 shows the block diagram of the API monitoring system. The particle sensor detects the concentration of particle in environment and converts it into a voltage signal. Sharp's GP2Y1010AU0F is an optical air quality sensor, designed to sense dust particles. An infrared emitting diode and a phototransistor are diagonally arranged into this device, to allow it to detect the reflected light of dust in air. It is especially effective in detecting very fine particles like cigarette smoke, and is commonly used in air purifier systems. The sensor has a very low current consumption (20mA max, 11mA typical), and can be powered with up to 7VDC. The output of the sensor is an analog voltage proportional to the measured dust density, with a sensitivity of  $0.5V/0.1mg/m^3$ . Arduino board analyses the signal and sent to an Android through Bluetooth module.

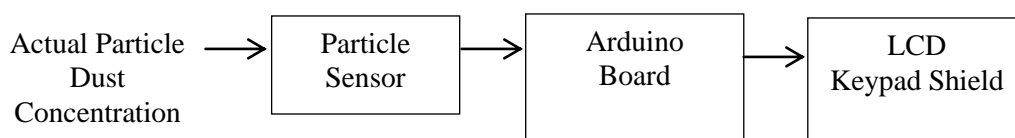

Figure 3.2: Block Diagram of API Monitoring System



### 3.4 Hardware Development

#### 3.4.1 Hardware Selection and Development Platform

This project will be focusing on the development of control system for the optical dust sensor. The development board used for this project is Arduino Uno and optical dust sensor used for this purpose is Sharp GP2Y1010AU0F optical dust sensor.



Figure 3.3: Arduino Uno

Figure 3.3 shows the Arduino Uno board. The device compiler chosen for the project is Arduino Uno which based on the ATMEGA ATmega328-p microcontroller [12]. The Arduino Uno is a microcontroller board based on the ATMEGA ATmega328 microcontroller. It consists of 14 digital input/output ports which 6 of it can be used as Pulse Width Modulation (PWM) outputs. Besides that, there are 6 analog inputs, 16MHz ceramic resonator, USB connection, power jack, In Circuit Serial Programming (ICSP) header and a reset button on the board. Arduino Uno is a compact and all in 1 microcontroller board which is very useful in various projects in control system, robots and so on. The operating voltage of the board is 5. The board can be powered by computer through USB connector and also AD-to-DC adapter or battery at an external supply of 6 V to 20 V. The recommended input voltage is from 7 V to 12 V.

### 3.4.2 Air Particle Optical Sensor

In sampling the air particles on this project, the principal on evaluating the size and number of particles using optical method is used. Sharp GP2Y1010AU0F is a dust sensor by optical sensing system. An infrared emitting diode (IRED) and a phototransistor are diagonally arranged into this device. It detects the reflected light of dust in air. Especially, it is effective to detect very fine particle like the cigarette smoke. In addition it can distinguish smoke from house dust by pulse pattern of output voltage. The characteristics of detecting a very fine particle make it suitable for this project as its aim is to detect and measure fine particle volume in environment either indoor or outdoor.

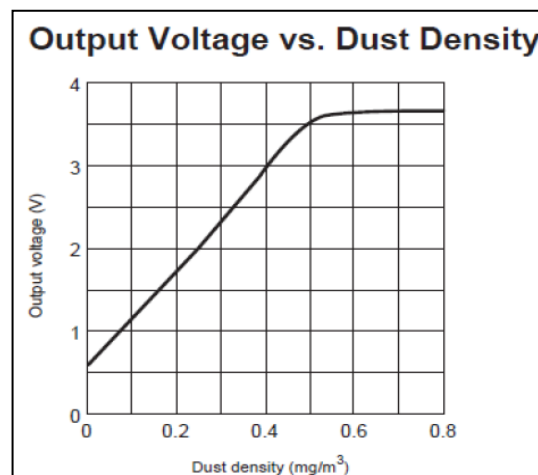

Figure 3.4: Output Voltage versus Dust Density

Figure 3.4 shows the Output Voltage vs. Dust Density for the optical sensor. The sensor is based on one operation principle; a light beam is emitted into the measurement chamber. When dust is present, the light is refracted by particles and the amount of scattered light is detected.

(T<sub>a</sub>=25°C, V<sub>CC</sub>=5V)

Parameter	Symbol	Conditions	MIN.	TYP.	MAX.	Unit
Sensitivity	K	*1 *2 *3	0.35	0.5	0.65	V/(0.1mg/m <sup>3</sup> )
Output voltage at no dust	V <sub>OC</sub>	*2 *3	0	0.9	1.5	V
Output voltage range	V <sub>OH</sub>	*2 *3 R <sub>L</sub> =4.7kΩ	3.4	–	–	V
LED terminal current	I <sub>LED</sub>	*2 LED terminal voltage = 0	–	10	20	mA
Consumption current	I <sub>CC</sub>	*2 R <sub>L</sub> =∞	–	11	20	mA

Figure 3.5: Parameter for Optical Sensor

Figure 3.5 shows the parameter for the optical sensor. According to the sensitivity parameter declared by Sharp GP2Y1010AU0F optical sensor is V/(0.1mg/m<sup>3</sup>) means that each increment in voltage output is per 0.1mg/m<sup>3</sup> of particle volumes. The maximum output voltage can be read by the sensor is (+-) 3.6V which is returns the dust density level to 0.5mg/m<sup>3</sup>. According to the Malaysia Ambient Air Pollution Level, the TSP maximum level is 260µg/m<sup>3</sup> = 0.26mg/m<sup>3</sup>. The rating level is still within the specified range of the sensor. Thus, the system will give an output warning in visual (e.g. LED blinking) if the pollution level is above the maximum range stated [13].

### 3.4.3 LCD Keypad Shield

This is a very popular LCD Keypad shield for Arduino and other variants. It includes a 2x16 LCD display and 6 momentary push buttons. Pins 4, 5, 6, 7, 8, 9 and 10 are used to interface with the LCD. Just one Analog Pin 0 is used to read the five pushbuttons. The LCD shield supports contrast adjustment and back-lit on/off functions. It also exposes five analog pins with DFRobot color code for easy analog sensor plugging and display. The on board LED indicates power on.



Figure 3.6: LCD Keypad Shield

This design is great since easily lets you keep connecting sensors to the rest of the pins, and use it for monitoring or menu selection with the push buttons even for gaming. Often project applications require testing or debugging. Displaying information right away help on most occasions when a computer is not at reach. If you are planning to build something not attached to a computer and you need to check what is going on when you place it on position, this addition will prove very valuable to make sure the program is running well [14].

## 3.5 Software Development

### 3.5.1 Software selection

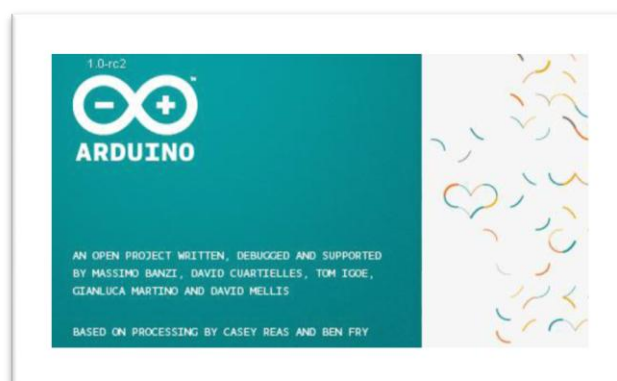

Figure 3.7: Arduino IDE

In software part, Arduino IDE used to interface with Arduino board. Arduino IDE is an open-source environment that makes it easy for the user to write code and programmed to the Arduino board. The Arduino IDE software consists of an Integrated Development Environment (IDE) and the core libraries. The IDE is written in Java and based on the processing development environment. The core libraries are written in C and C++. Figure 3.7 shows the Arduino Software[15].

## **CHAPTER 4**

### **RESULT AND ANALYSIS**

#### **4.1 Introduction**

In this chapter, the result of this project, i.e. the final hardware design of the system and the outcome of the measurements, and its analysis are discussed. The measurements are carried out at five different location. The reading at each location will be presented and compared with the data acquired by Ministry of Natural Resources and Environment.

#### **4.2 Hardware Design**

The hardware of the project is assembled in an acrylic box. The Sharp GP2Y1010AU0F optical dust sensor is placed on top of the Arduino Uno. The casing of the system is made by acrylic material and screwed firmly, thus it is light, portable and user friendly because the component is assembled as compact as possible. This allows user to carry it along and place at anywhere either indoor or outdoor [16].

The connection between Arduino Uno and the sensor is referred to the schematic diagram in Figure 4.1. The green and black jumper wires connect the Vcc

terminals of pin 1 and pin 6 of the sensor to 5V pin in Arduino Uno. This is because the sensor is power up by Arduino. The blue and grey jumper wires connect the ground terminals of pin 2 and pin 4 of the sensor to GND pin in the Arduino Uno. The white colour jumper wire connects the output pin which located at pin 5 of the sensor as illustrated in Figure 4.2. It is connected to the A0 pin of Arduino Uno [17]. Table 4.1 shows the pins assignments for sensor pins and Arduino pins.

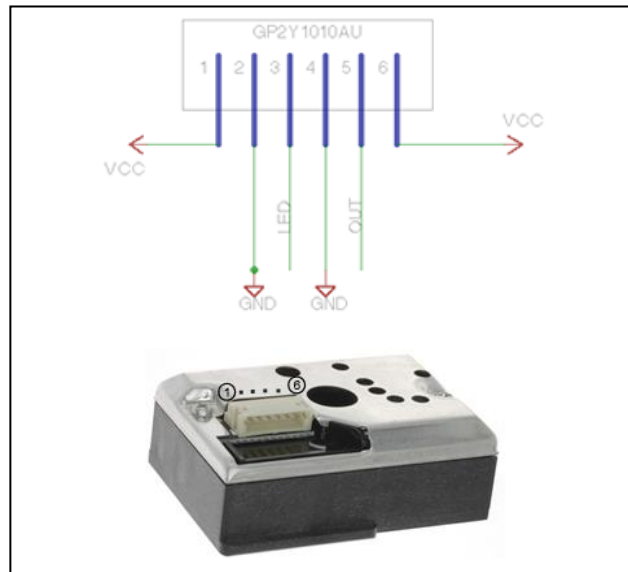

Figure 4.1: Connection Six Pins on Sensor

Table 4.1: Pins Assignments

Sharp Dust Sensor	Attached To
1 (V-LED)	5V Pin (150 Ohm in between)
2 (LED-GND)	GND Pin
3 (LED)	Digital Pin 12
4 (S-GND)	GND Pin
5 (Vo)	Analog Pin A0
6 (Vcc)	5V Pin (Direct)



Figure 4.2: Pin Colouring Wire on the Sensor

The LED pin has to be modulated with a cycle of 1ms as discussed in the datasheet. The LED seems to use a PNP transistor so to power on, the LED pin must actually receive a lower voltage. The connections are shown in Figure 4.3 and the complete hardware connection to the PC is shown in Figure 4.4.

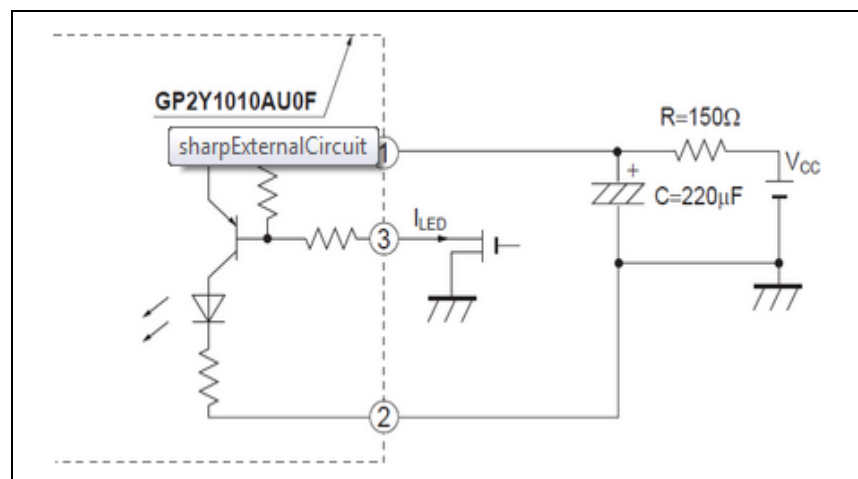

Figure 4.3: Official Schema from Sharp



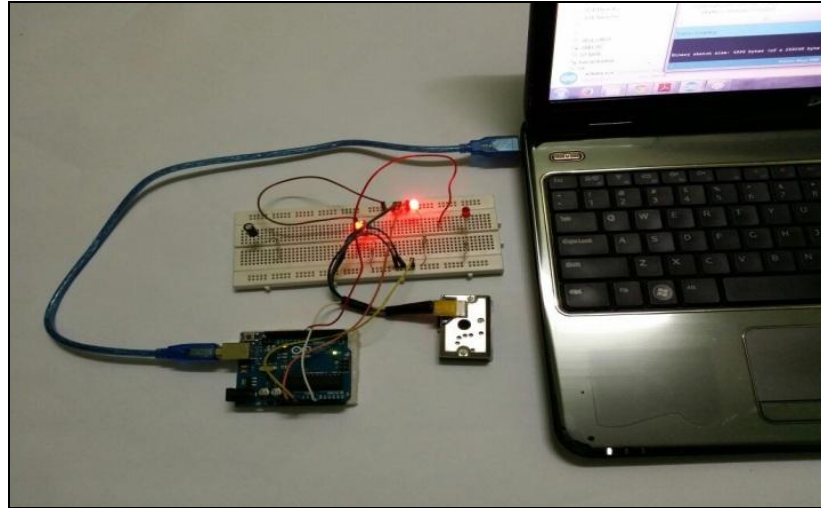

Figure 4.4: Connection between Arduino and Sensor

### 4.3 Arduino program

Arduino coding is based primarily to C programming, which mean some features of the C++ language may be used in more advanced programming features but are not used in this program. In Arduino-speak, the programs are called “sketch”. The coding is planned and designed according to the sequence of the flowchart to prevent errors. After the coding is done, the program need to compile and debug for error. After the sketch is verified, the window showed “Done Compiling” as in Figure 4.5. The result showed there is error free. The sketch is ready to upload to microcontroller in Arduino board through an USB cable [18].

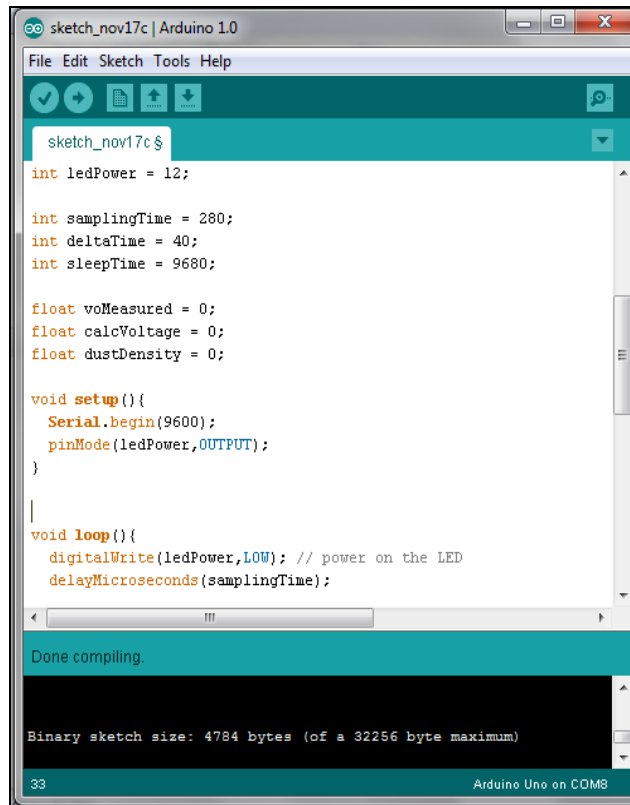

Figure 4.5: Done Compiling

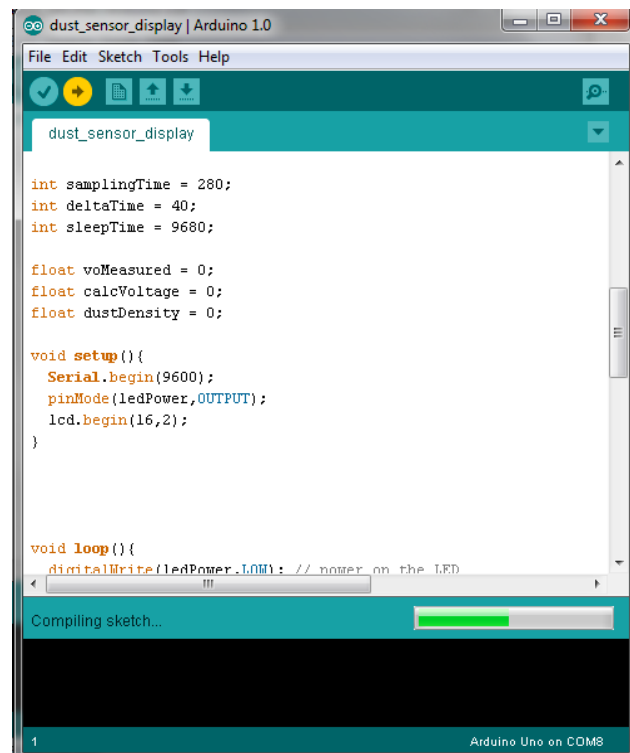

Figure 4.6: Compiling Sketch

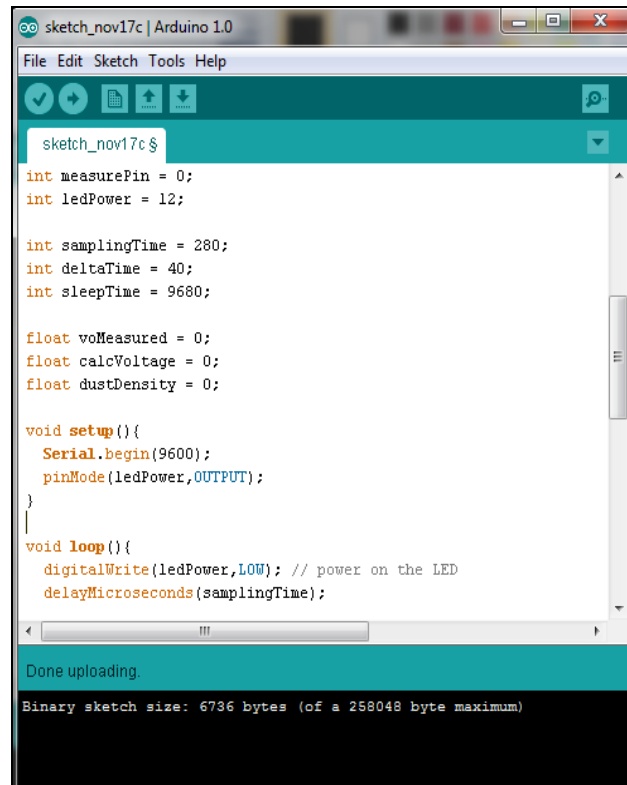

Figure 4.7: Done Uploading

After the verifying process is done, the sketch is uploaded to microcontroller through USB cable. Figure 4.7 shows the sketch is being uploaded to the microcontroller. As the sketch is uploaded, the sensor will start functioning and collect the data.

```

/*****Lcd display Dust Density*****/
lcd.clear();
lcd.print("Dust Den [ug/m3]");
lcd.setCursor(0,1);
lcd.print(dustDensity);
/*****Lcd display Dust Density*****/

Serial.print("Raw Signal Value (0-1023): ");
Serial.print(voMeasured);

Serial.print(" - Voltage: ");
Serial.print(calcVoltage);

Serial.print(" - Dust Density [ug/m3]: ");
Serial.println(dustDensity);

```

Figure 4.8: LCD Display Code

## REFERENCES

1. Air Pollutants and It's sources; Wisconsin Department of Natural Resources (2014). Retrieved November 30, 2014, from <http://dnr.wi.gov/topic/AirQuality/Pollutants>.
2. Daly, A. and P. Zannetti. 2007. *An Introduction to Air Pollution – Definitions, Classifications, and History*. Chapter 1 of Ambient Air Pollution (P. Zannetti, D. Al-Ajmi, and S. Al-Rashied, Editors). Published by The Arab School for Science and Technology (ASST)
3. Masitah, A. *PM10 and Total Suspended Particulates (TSP) Measurements In Various Power Stations*; The Malaysian Journal of Analytical Sciences, Vol 11, No 1 (2007): 255-261
4. EPA Air Pollution Cost Manual (2012). Retrieved December 10, 2014, from [http://www.epa.gov/ttn/catc1/dir1/c\\_allchs.pdf](http://www.epa.gov/ttn/catc1/dir1/c_allchs.pdf)
5. Mokhloss, I.&Valentin, S. *Dust monitoring systems*. In ICSNC 2011, The Sixth International Conference on Systems and Networks Communications. 2011. pp. 68-71.
6. Oh, S. J., & Chung, W. Y. *Room environment monitoring system from PDA terminal*. In Intelligent Signal Processing and Communication Systems, 2004. ISPACS 2004. Proceedings of 2004 International Symposium. IEEE: 2004. pp. 497-501.
7. Kim, S., & Paulos, E. (2010, April). *InAir: sharing indoor air quality measurements and visualizations*. In Proceedings of the 28th international conference on Human factors in computing systems. ACM:2010. pp.1861-1870.
8. P. Qili. *Room Dust Monitoring System*. Bachelor Degree Thesis. Universiti Tun Hussien Onn Malaysia; 2013.

9. Rabihah, A.R *Rekabentuk dan Pembangunan System Pemantauan Kualiti Udara dan Penggera*. Bachelor Degree Thesis. Universiti Tun Hussien Onn Malaysia; 2009.
10. Khairrolhelmi, T. *Plantation Monitoring System using Multiple Sensor and Arduino Uno*. Bachelor Degree Thesis. Universiti Tun Hussien Onn Malaysia; 2014.
11. Noor Shazliza, Z. *Rice Husk/Dust Air Particle Sensor Using Zigbee Wireless Sensor Network*. Degree of Master Thesis. Universiti Tun Hussien Onn Malaysia; 2013.
12. Beychok, M.R. (2005). *Fundamentals of Stack Gas Dispersion*, 4th Edition, author-published. ISBN 0-9644588-0-2.
13. SensorApp (2010). *Sharp Dust Sensor and Arduino*. Retrieved October 15, 2014, from <http://sensorapp.net/sharp-dust-sensor-and-arduino/>
14. DfRobot (2014). *LCD Keypad Shield for Arduino*. Retrieved December 5, 2014 from [http://www.dfrobot.com/index.php?route=product/product&product\\_id=51](http://www.dfrobot.com/index.php?route=product/product&product_id=51).
15. Janssen, N., Schwartz, J., Zanobetti, A., & Suh H.H. *Air Conditioning and Source Specific Particles as Modifiers of The Effect of PM on Hospital Admissions For Heart And Lung Disease*. Environ Health Perspect 2002;110:43e9.
16. Peters, A., Dockery, D.W., Muller, J.E., & Mittleman, M.A. *Increased Particulate Air Pollution and The Triggering of Myocardial Infarction*. Circulation 2001;103:2810e5.
17. He, C., Morawska, L., Hitchins, J., & Gilbert, D. *Contribution from Indoor Sources to Particle Number and Mass Concentrations in Residential Houses*. Atmos Environ 2004;38:3405e15.90.
18. Luoma, M., & Batterman, S.A. *Characterization of Particulate Emissions From Occupant Activities in Offices*. Indoor Air 2001;11:35e48.
19. Wallace, L., & Howard-Reed, C. *Continuous Monitoring Of Ultrafine, Fine, And Coarse Particles in A Residence For 18 Months in 1999-2000*. J Air Waste Manag Assoc 2002;52:828e44.

20. National Research Council: Committee on Air Quality Management in the United States, Board on Environmental Studies and Toxicology, Board on Atmospheric Sciences and Climate, Division on Earth and Life Studies (2004). *Air Quality Management in the United States*. National Academies Press. ISBN 0-309-08932-8.
21. Daud, Z., Ridzuan, M.,B. & Ahmad, Z. (2014). *Laporan Pemantauan Kualiti Udara PM10 and TSP*. UTHM Commercial Sdn.Bhd.