

www.arnjournals.com

INVERTERS TESTING WITH TMS320F28335 USING SIMULINK BLOCK MATHEMATICAL MODELS

Shamsul Aizam Zulkifli, Muhammd Faddil Ahmad

Rebudi, Mohd Quzaifah

Department of Electrical Power Engineering, Faculty of Electrical and Electronics Engineering,
Universiti Tun Hussein Onn Malaysia (UTHM), 86499 Parit Raja, Batu Pahat, Johor.D.T, Malaysia
E-Mail: aizam@uthm.edu.my

ABSTRACT

This paper presents the usage of Matlab-Simulink block diagram in order to create a controller block diagram based on mathematical equation and to be used as a tested controller for the inverters. The controllers which are the PI and PID controller have been used and been downloaded to the TMS320F28335 microcontroller board. These controllers and microcontroller have been applied to the three phase inverter and to the 2-level three phase multi-level-inverter. From the results, its show that, the controllers that been designed using the Simulink block diagram are able to communicate with the microcontroller for controlling the voltage output at the inverters.

Key words: Matlab-Simulink • 3 phase inverter • multilevel inverter • TMS320F28335

INTRODUCTION

Recently, more and more advanced control theories have been adapted to the operation of the power electronic converters just using the mathematical equations. These controllers can be tested to the converters if a suitable microcontroller has been selected in order to be a medium of interfacing between the hardware and the software part.

Generally, controller can be divided into two main groups that are conventional controller and unconventional controller. The examples of conventional controller such as Proportional (P), Proportional-Integration (PI), Proportional-Derivative (PD), Proportional-Integration-Derivative (PID) and Otto-Smith controller (Vukic, Z., 2012). As a result for these controllers, a mathematical model for the control process is needed in order to be used as a controller. Meanwhile, combination of several controllers such as PI and PD controllers are very often in practical systems while the PID controller can be integrated with inverter to ensure a stable output voltage (Ari, K., Asal, F. T., and Cosgun, M., 2012). Meanwhile, the examples of unconventional controller are fuzzy controller and neuro-fuzzy controller's controller (Vukic, Z., 2012).

Power inverters such as a three phase inverter and multilevel inverter are widely used in industrial application. These converters can provide variable outputs voltage that are required by the load. For an example, the inverter is used to change from the DC input source to the AC output voltage (Zulkifli, S.A., Md Tomari, M.R, Hussin, M.N., Saad, A.S., Ab Ghani, M.K.A., Deraman, F., Berahim, N., and Abdullah, A.H., 2015). Nevertheless, in order to minimize the losses at the transformer, a converter that operates in transformerless mode but with higher voltage output from the input has been introduced in 1974 by (Baker, R.H., and Bannister, L.H., 1975) which is known as multilevel inverter.

Multilevel inverter is a series of power semiconductor switches with several low voltage DC sources to perform the increase power conversion by synthesizing a staircase voltage waveform (Khomfoi, S., and Toolbert L.M accessed on July 2014). It begins with

the three – level converter and since then, several topologies have been developed (Nabae, A., Takahashi,I., and Akagi, H., 1981). Among the widely used topology is cascaded H – bridge inverter with separate dc sources, diode clamped and flying capacitors.

The advantages of having multilevel inverter compare to single level inverter are the waveform quality which has low distortion level at the output and the input current will reduce the dv/dt stresses on semiconductor devices and reducing electromagnetic concern on switching operations (Mohan, N., Undeland, T.M., and Robbins, W.P ,2003), (Agrawal, J. P.,2011), (Baker , R.H., and Bannister, L.H., 1975), (Khomfoi, S., and Toolbert, L.M., accessed on July 2014), (Rodriguez, J., Jih-Sheng Lai, and Fang Zheng Peng, 2002).

TMS320F28335 is a family of C2000 microcontroller that been developed by the Texas Instruments (TI) (Texas Instrument, 2006). This board has ability to communicate with the MATLAB-Simulink block diagram as a working condition for the operation of the microcontroller same as others low cost microcontrollers such as Arduino (Zulkifli, S.A., Hussin, M. N. and Saad, A S, 2015), (Zulkifli, S.A., Ab Ghani, M.K.A., Deraman, F., Berahim, N., Abdullah, A.H. and Md Tomari, M.R, 2015), (Zulkifli, S.A., Md Tomari, M.R, Hussin, M.N., Saad, A.S., Ab Ghani, M.K.A., Deraman, F., Berahim, N., and Abdullah, A.H., 2015), (Zulkifli, S.A., Yusof, S.M., Hussian, A.H., Arifin, A.I.M, Ismail@Marzuki, M.S.N., WanChek, W.A.K., and Tazudin, F.R.M., 2015).

This advantage has created a simple solution for the beginner engineer, to understand the process between the microcontroller and the control strategy. It also makes, the control theory which is mostly based to complex mathematical formulation can be designed in Simulink blocks and then downloaded to the microcontroller after these blocks have been changed to C language codes by MATLAB.



In this paper, two power inverters have been build and tested in order to see the capability of the TI microcontroller and the Simulink block in generating the output waveform at the inverters. The first test, a 3 phase inverter with PID voltage controller was tested. The second test was conducted to the multilevel inverter with 2-level inverter output. This multilevel inverter uses a current feedback response with the PI controller strategy whereas able to reduce the input error at the controller (Zulkifli, S.A., Hussin, M. N. and Saad, A S, 2014)

Testing on 3-phase inverter

The simulation closed loop system for the three-phase inverter with PID controller is shown in Figure 1.

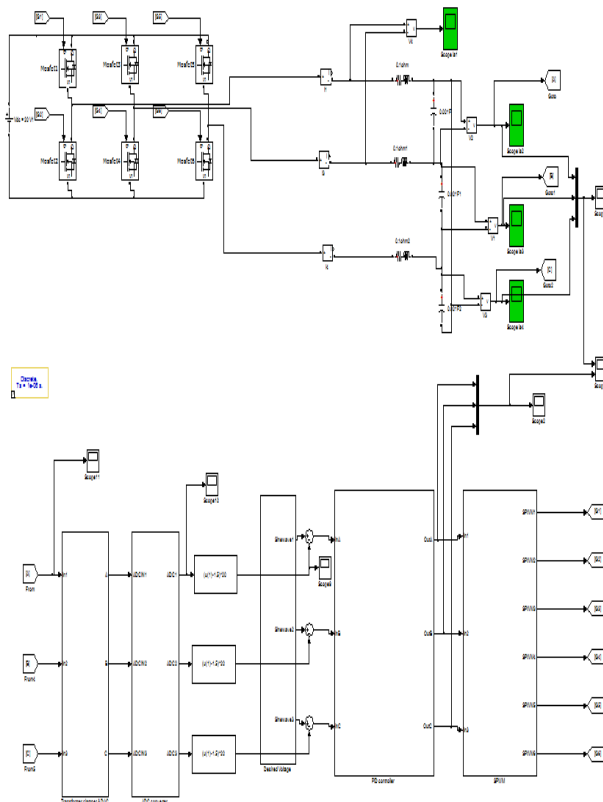

Figure 1: Inverter Circuit Simulations for Closed Loop

Here, the PID controller is used as a controller where it been model based on Equation 1 using and then modeled it in Simulink block. Figure 2 shows the control strategy with the feedback response to be compared to the setting voltage for output signal generation by the PWM.

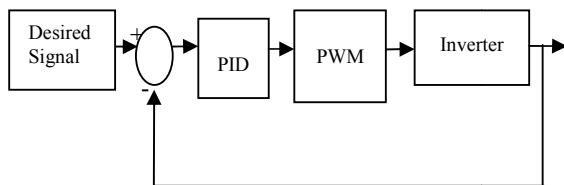

Figure 2: PID Control System Block Diagram

$$u(t) = MV(T) = K_p(e(t) + K_i \int_0^t e(\tau) d\tau + K_d \frac{de(t)}{dt}) \quad (1)$$

The K_p , K_i and K_d value are tuned based on manual tuning or trial and error method that has been used in this paper in order to have -1 to 1 for minimum error mechanism. The PID control tuning can be summarize from Table 1.

Table 1: PID Tuning Summation for Simulation

Gain	Voltage Change
K_p	To set the maximum voltage after filter
K_i	To fine tune the output voltage after filter
K_d	To make voltage level smoother

For the simulation parameters, the DC input voltage is set at 20Vdc and the voltage reference is set to 12V to test the PID controller response. The PID controller is then been tuned until the output of the three-phase inverter has 12V_p as shown in Figure 3. The final value for K_p is 8.5, K_i is 1 and K_d is $1e^{-6}$.

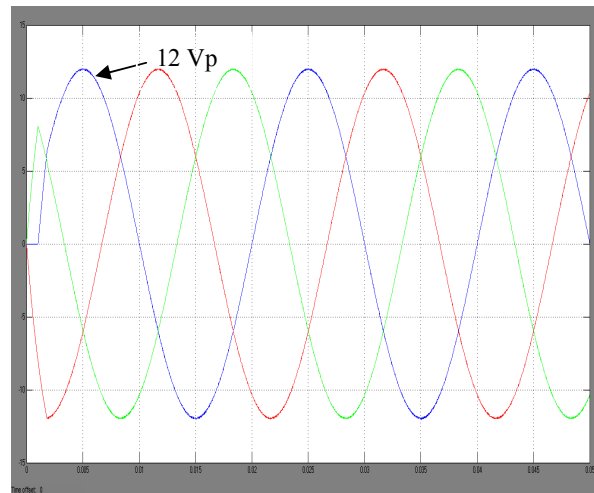

Figure 3: Simulation Inverter Output Voltage for Close Loop

Hardware Open Loop and Closed loop Result for 3 phase inverter

The hardware testing has been done with all the power circuit and the TMS320F28335 board as shown in Figure 4. The digital output port is set at GPIO0, GPIO2, and GPIO4 and connected to the driver circuit.

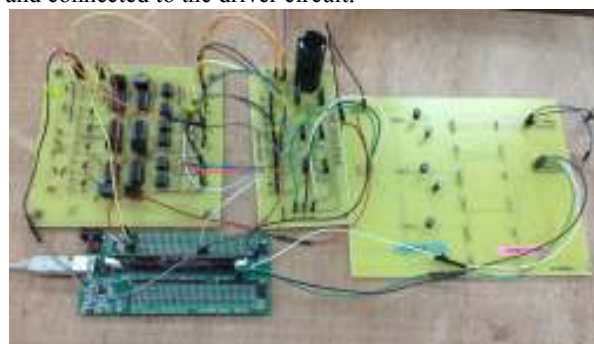

Figure 4: Hardware experimental setup for 3 phase inverter



The hardware results of the open loop system are shown in Figure 5 and Figure 6. Figure 5 shows the maximum output of three-phase inverter is around 20V before filtering process. Meanwhile Figure 6 shows the maximum voltage output at 17V sine signal after filtering process. The filter design will not be discussed in this paper. There is 3V loss after applying the filter circuit due to no consideration of the bandwidth of the low pass filter.

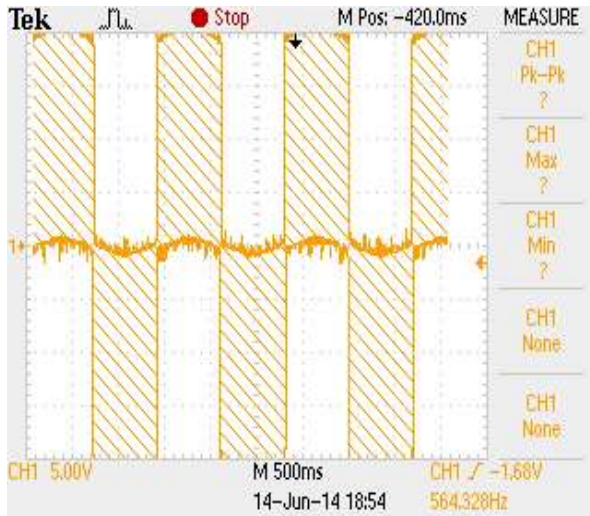

Figure 5: Three Phase Inverter Output before Filter

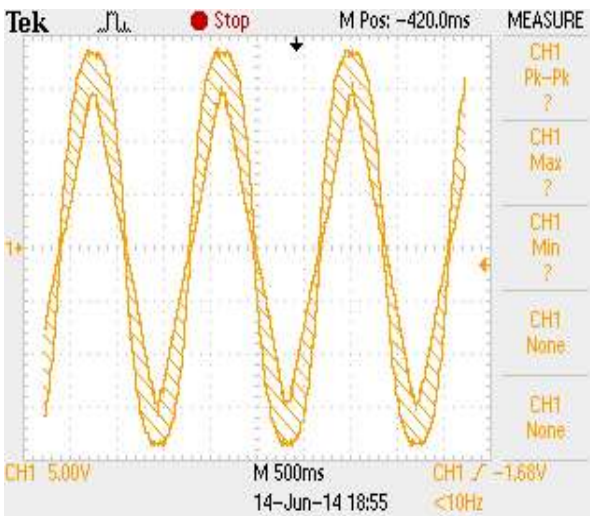

Figure 6: Three Phase Inverter Output after Filter

The hardware testing for closed loop is done by developing the controller circuit as shown in Figure 7. This diagram has been model in MATLAB. The result at the line to line voltage with the selected gains value is shown in Figure 8. It shows that, the inverter output needs more controller gains tuning in order to get better result. After several tuning process the new final value for hardware Kp, Ki and Kd are 0.03, $1e^{-4}$, $1e^{-6}$ have been tuned which is based to the method given in Table 1. Figure 9 shows the better live voltage using the new gains and the output follows the setting reference voltage at 12 V

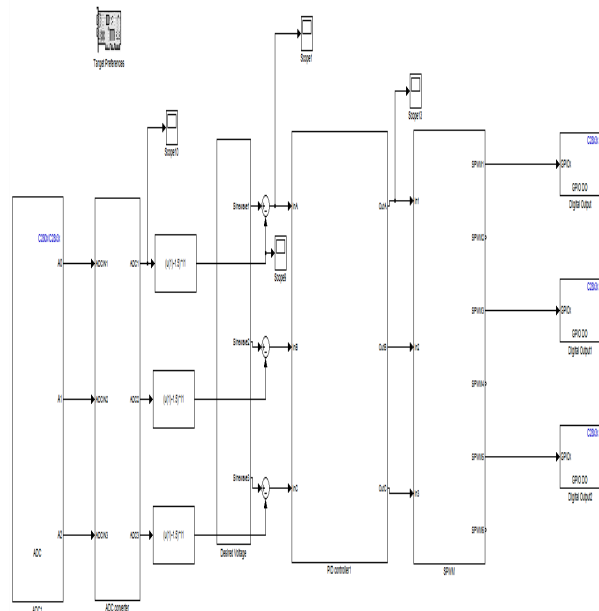

Figure 7: Closed Loop Matlab Simulink Circuit for Hardware Implementation

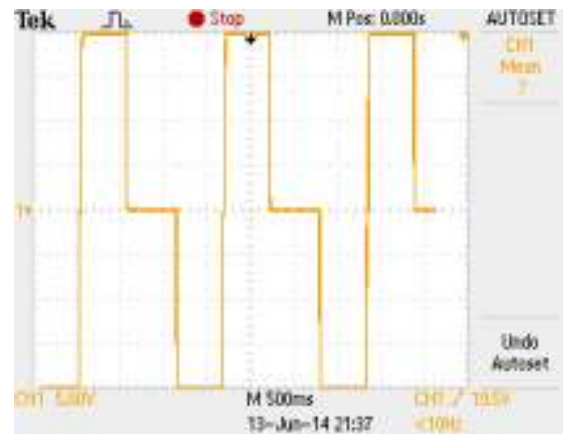

Figure 8: Line To Line Voltage Output

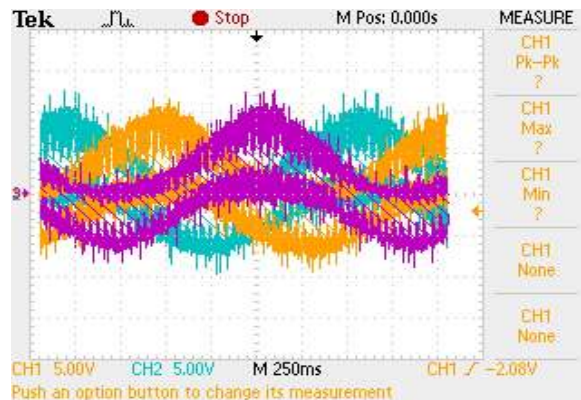

Figure 9: Line to Neutral Output Value for Inverter after Filter



Testing on Multilevel Inverter

The second experiment is conducted to the multilevel inverter which has 2-level output for every half cycle output. This level will help the authors to reduce the dependency of the filter design and make the inverter as a transformerless system by increasing the output voltage. The feedback current with PI control strategy has been tested to this experiment.

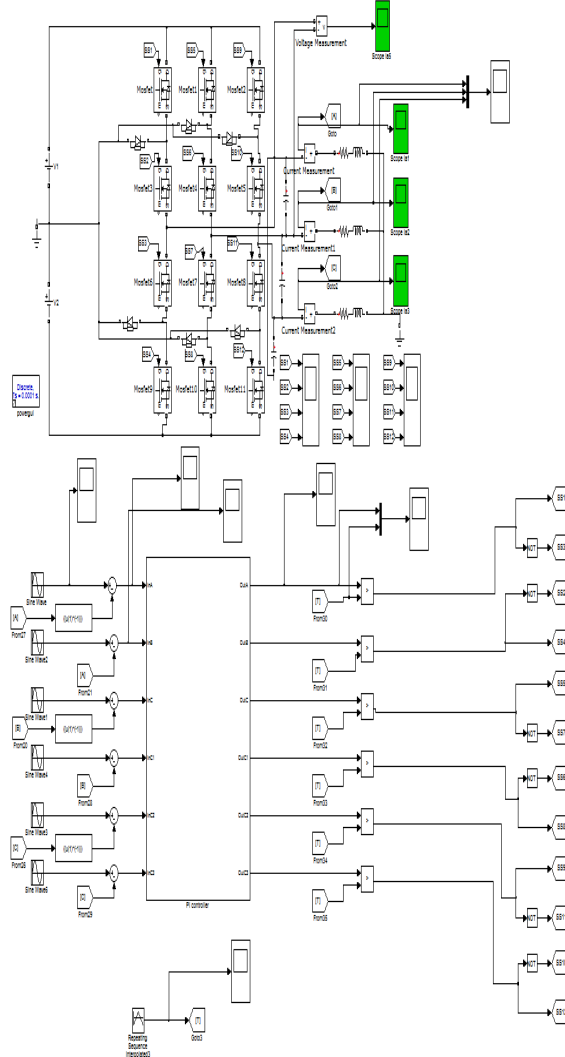

Figure 10: Simulink model of the multilevel inverter.

Figure 10 shows the simulation modeling of the multilevel inverter system. Two inverters are cascaded to form the multi-level inverter, which is connected to the RLC load. Figure 11 shows the converter system model of the multilevel inverter. It needs, 12 switching signals to be produced to control the operation of the inverter. Sinusoidal Pulse Width Modulation (SPWM) signals are used in this project, in where the sine reference signal is being compared with triangular signal and depending on the in the interval by applying the hysteresis concept for producing 0 and 1 for the PWM output signal.

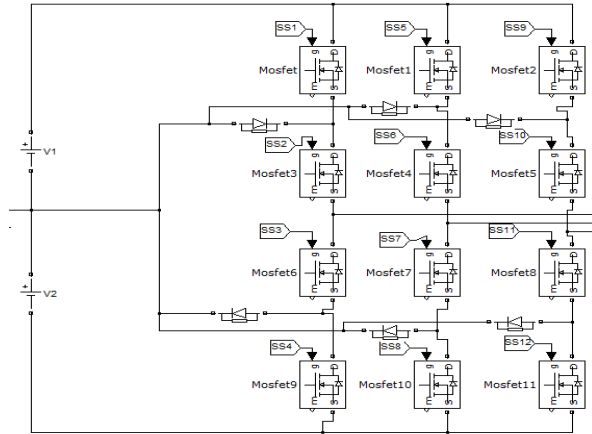

Figure 11: Multilevel (2 stages) inverter model.

Figure 12 shows the PI controller design with the current feedback while Figure 13 shows the PI controller block that been build in the using Simulink blocks. The value of K_p and K_i for this simulation are selected based on the trial and error method where $K_p = 12$ and $K_i = 0.001$.

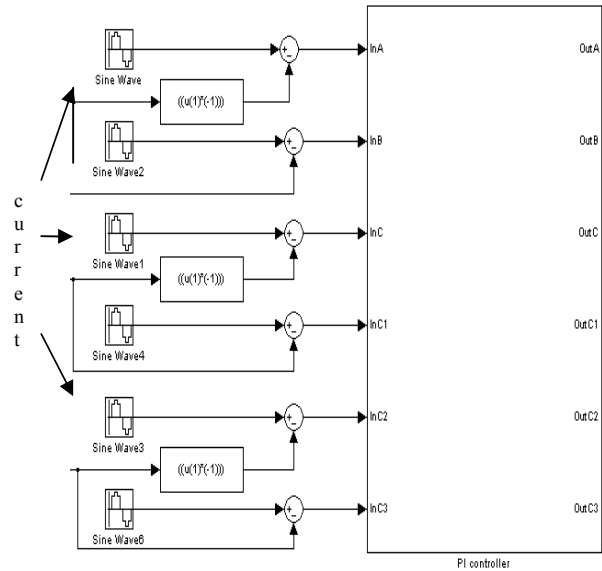

Figure 12: PI controller block (subsystem).

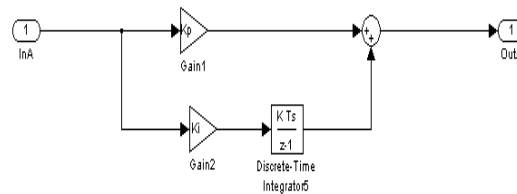

Figure 13: Proportional and Integral control block.

Figure 14 shows the inverter output voltage measurement at no load condition for phase a, b and c. The DC input is set 10V and it generates 2 level signal for with 20V magnitude.

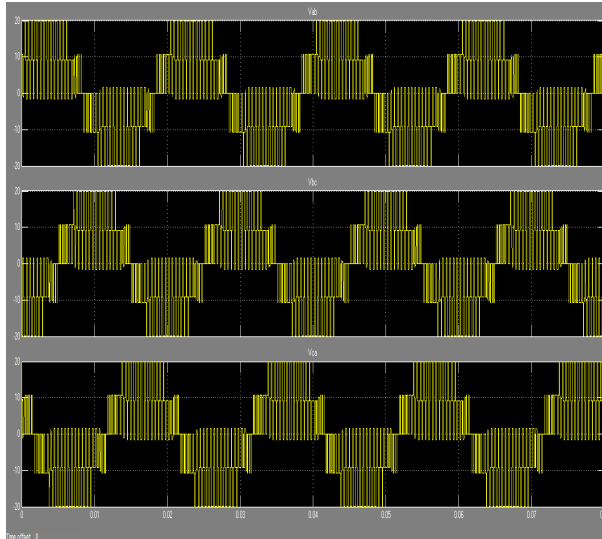

Figure 14: Voltage measurement when no load at all phases

Figure 15 shows the output voltage when RLC loads are applied at every phases after the multilevel inverter. The magnitude is the same as in Figure 14 but the waveform is in sinusoidal signal.

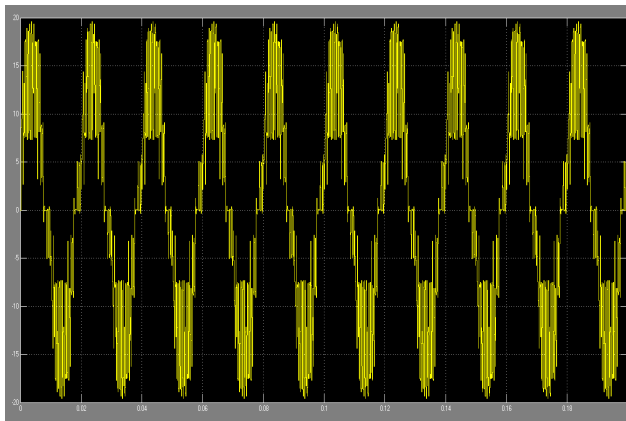

Figure 15: Multilevel voltage measurement with RLC load

Hardware Open loop test on Multilevel Inverter

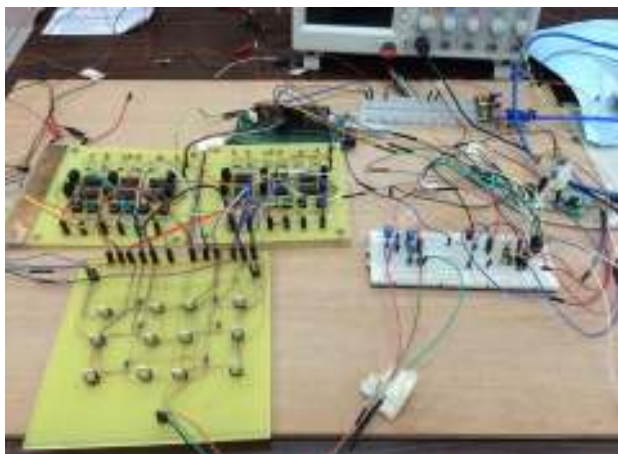

Figure 16: Multilevel inverter in experimental setup

Figure 16 shows the full hardware setup for the multilevel inverter. Two DC supplies are used in providing two same inputs to the multilevel inverter. The load components used for this test are $R = 10\Omega$, $L = 2.2\mu H$ and $C = 100\mu F$.



Figure 17: Phase voltage at no load

Figure 17 shows the voltage output of the multilevel inverter in phase a when no load condition. As a result, 2 stages inverter will produce 2-level output with the magnitude of 20 V and as same as in Figure 14. Two stages inverter will produce twice the output of the power supplied, which is 10V and with this, giving a total of 20V can be observed on the oscilloscope. At the meantime, Figure 18 shows the result when the load has been connected and it looks like in Figure 15.

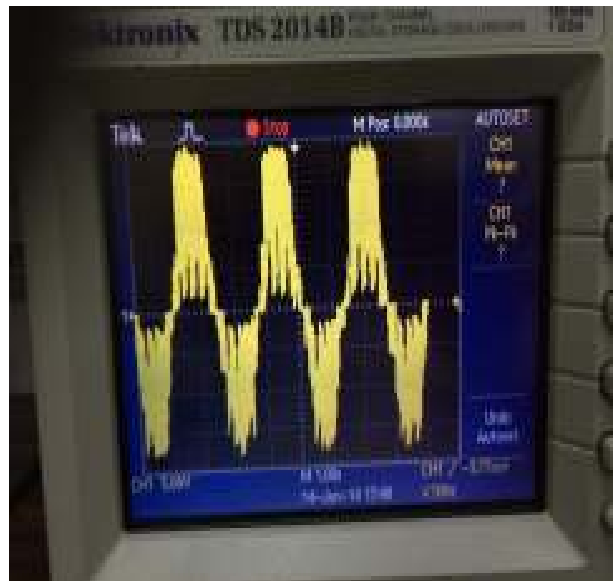

Figure 19: Phase a with load.

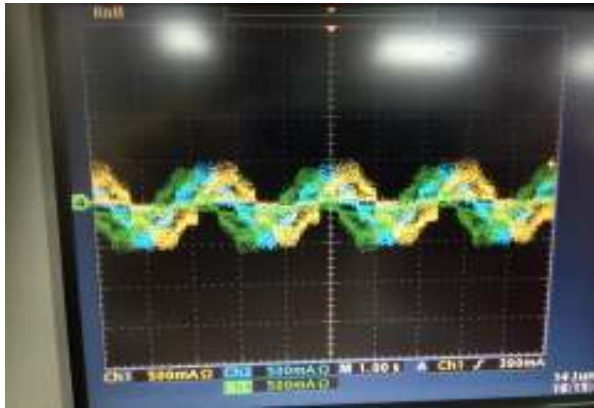

Figure 19: Inverter current output

Figure 19 shows the line current of the open loop system that been measured using current sensor ACS756. It shows that the current is around of 500mA with small phase different where indicates, the current feedback is not working properly due to the wrong sizing of the sensor. This setup required low range sensor with high sensitivity.

CONCLUSION

As a conclusion, the implementation of mathematical formulas in control theory is easy to be used with the help of Matlab-Simulink library that able to generate the C code that is needed by the TI microcontroller board. It also will help the board to generate the control signal for the inverter operation based on conventional controller with voltage feedback. For the future, more complex control equations such as in the robust control theory with more sensitive parameter inputs from the inverter can be included for better result and performances.

REFERENCE

- Vukic, Z., "Lectures on PID", University of Zagreb, 2012,
- Ari, K., Asal, F. T., and Cosgun, M., "EE 404: Discrete Time Systems Project Report PI, PD, PID", Middle East Technical University, 2012
- Mohan, N., Undeland, T.M., and Robbins, W.P., "Power Electronics- Converters, Applications and Design" 3rd. ed. John Wiley & Sons, Inc, New York. 2003.
- Agrawal, J. P. "Power Electronic Systems: Theory and Design". Upper Saddle River, NJ, Prentice Hall, 2001.
- Baker, R.H., and Bannister, L.H., "Electric Power Converter," U.S. Patent 3 867 643, Feb. 1975.
- Khomfoi, S., and Toolbert, L.M., "Multilevel Power Converters" The University of Tennessee, www.hcmut.edu.vn assessed on 20 July 2014
- Rodriguez, J.; Jih-Sheng Lai; and Fang Zheng Peng; "Multilevel Inverters: a Survey of Topologies, Controls, and Applications", *IEEE Transactions on Industrial Electronics*, Volume: 49, Issue: 4, Aug. 2002

Nabae, A., Takahashi, I., and Akagi, H., "A New Neutral-point Clamped PWM inverter," *IEEE Trans. Ind. Application.*, vol. IA-17, pp. 518-523, Sept./Oct. 1981.

Zulkifli, S.A., Hussin, M. N. and Saad, A. S., "MATLAB-Arduino as a low cost microcontroller for 3 phase inverter" *2014 IEEE Student Conference on Research and Development (SCORED)*, 2014, Page(s): 1 – 5

Zulkifli, S.A., Ab Ghani, M.K.A., Deraman, F., Berahim, N., Abdullah, A.H. and Md Tomari, M.R., "Investigation on various Voltage Controllers for 3 phase rectifier using Arduino as a Low Cost Microcontroller", (*accepted and to be published in Trans. Tech. Publications. on July 2015*)

Zulkifli, S.A., Md Tomari, M.R, Hussin, M.N., Saad, A.S., Ab Ghani, M.K.A., Deraman, F., Berahim, N., and Abdullah, A.H., "Understanding Robust Control on Arduino Microcontroller Testing in Power Electronics Converters", (*accepted and to be published in Trans. Tech. Publications., July 2015*)

Zulkifli, S.A., Yusof, S.M., Hussian, A.H., Arifin, A.I.M, Ismail@Marzuki, M.S.N., WanChek, W.A.K., and Tazudin, F.R.M., "Marlab-Simulink Controller Design for Arduino Target on AC Motor Control Application", (*accepted and to be published in Inter. Journal. Eng. Pow. Engineering Research July 2015*)

<http://www.ti.com/product/tms320f28335> (assessed on 14 June 2014)