

DEVELOPMENT OF AN AC-DC BUCK-BOOST POWER FACTOR  
CORRECTION

SAHRUDIN BIN SAAD

A project report submitted in partial  
fulfillment of the requirement for the award of the  
Degree of Master of Electrical Engineering

Faculty of Electrical and Electronics Engineering  
Universiti Tun Hussein Onn Malaysia

FEBRUARY 2013

## **ABSTRACT**

Increasing the power quality is a subject which has received increased attention in recent years. Power factor correction (PFC) is one of the power quality points which is receiving greater attention as evidenced by the number of manufacturers which are manufacturing various types of integrated circuits for power factor correction. Nonetheless, Power Factor Correction with AC-DC Buck Boost Converter is still infrequently being used. This project proposes of a development of AC-DC Buck Boost Power Factor Correction to improve the power factor to the near unity (0.99). For this project, the two objectives that have been identified are to develop the design of the AC-DC Buck-Boost Power Factor Correction model and to implement the simulation of AC-DC Buck-Boost Power Factor Correction. The Matlab Simulink software is used to do the design of the circuit experimented; Circuit without any PFC circuit, Circuit with open-loop PFC circuit and Circuit with closed-loop PFC circuit.. The results conclude that there is improvement of the power factor using the proposed AC-DC Buck Boost Power Factor Correction.

## ABSTRAK

Meningkatkan kualiti kuasa elektrik telah menjadi perhatian sejak kebelakangan ini. Peningkatan faktor kuasa (PFC) merupakan salah satu cara meningkatkan kualiti kuasa elektrik serta teknik yang mendapat perhatian yang meluas. Ini dibuktikan dengan banyaknya syarikat yang menghasilkan pelbagai jenis litar bersepadu untuk peningkatan faktor kuasa. Walaubagaimanapun Peningkatan faktor kuasa (PFC) dengan penukar AC-DC Buck-Boost masih jarang digunakan. Projek ini mencadangkan pembangunan *AC-DC Buck-Boost Power factor correction (PFC)* untuk meningkatkan faktor kuasa hingga ketahap yang lebih baik (0.99). Projek ini telah mengenalpasti 2 objektif iaitu membangunkan rekabentuk model *AC-DC Buck-Boost Power factor correction (PFC)* dan melaksanakan simulasi *AC-DC Buck-Boost Power factor correction*. Perisian *Matlab Simulink* digunakan untuk merekabentuk litar; litar yang tidak menggunakan litar PFC, litar yang menggunakan litar terbuka PFC dan litar yang menggunakan litar tertutup PFC. Keputusan yang dihasilkan menunjukkan terdapat peningkatan factor kuasa menggunakan *AC-DC Buck-Boost Power factor correction (PFC)* seperti yang dicadangkan.

## TABLE OF CONTENTS

<b>CHAPTER</b>	<b>ITEM</b>	<b>PAGE</b>
	<b>TITLE</b>	i
	<b>DECLARATION</b>	ii
	<b>DEDICATION</b>	iii
	<b>ACKNOWLEDGEMENT</b>	iv
	<b>ABSTRACT</b>	v
	<b>ABSTRAK</b>	vi
	<b>TABLE OF CONTENTS</b>	vii
	<b>LIST OF FIGURES</b>	x
	<b>LIST OF TABLES</b>	xii
	<b>LIST OF SYMBOLS AND ABBREVIATIONS</b>	xiii
<b>CHAPTER 1</b>	<b>INTRODUCTION</b>	
	1.1 Project Overview	1
	1.2 Problem Statements	3
	1.3 Project Objectives	4
	1.4 Project Scopes	4
<b>CHAPTER 2</b>	<b>LITERATURE REVIEW</b>	
	2.1 Theories	5

2.1.1	Introduction of Power Factor	5
2.1.2	Introduction of Buck-Boost Converter	6
2.1.2.1	Buck-Boost Converter Formula	8
2.1.3	Introduction of AC-DC Converter	12
2.1.4	Introduction of PID controller	13
2.1.5	Introduction to switching (Power semiconductor device)	13
2.1.5.1	MOSFET	14
2.1.5.2	IGBT	15
2.2	Description of Previous Methods	15
2.3	Conclusion	19
<b>CHAPTER 3</b>	<b>METHODOLOGY</b>	
3.1	Introduction	20
3.2	Power Factor	22
3.3	Buck-boost converter circuit	23
3.4	Ac/Dc Switching Power Supply	24
3.5	PID controller design	26
<b>CHAPTER 4</b>	<b>RESULTS AND ANALYSIS</b>	
4.1	Introduction	28
4.2	An Ac-Dc circuit without Power Factor Correction circuit	29
4.3	An Ac-Dc signal open loop Buck Boost Converter	32
4.4	An Ac-Dc Buck Boost Converter by using PID controller (close loop feedback)	35
<b>CHAPTER 5</b>	<b>CONCLUSION &amp; RECOMMENDATION</b>	
5.1	Introduction	38
5.2	Conclusion	38

5.3	Recommendation	40
-----	----------------	----

<b>REFERENCES</b>	41
-------------------	----

<b>APPENDICES</b>	44
-------------------	----

## LIST OF FIGURES

1.1	The Buck Boost PFC Circuit	2
1.2	Buck Boost Operation	2
2.1	Phasor Diagram of KW, KVA, KVA <sub>r</sub>	6
2.2	Continuous Mode Buck-Boost Power Stage Waveforms	7
2.3	Buck-Boost converter (a) Basic Circuit (b) Circuit when switch is closed (c) Circuit when switch is opened	8
2.4	Power semiconductor device variety	14
2.5	PFC BBC with Inductor Average Current Controller and PI Controller	16
2.6	Proposed Bridgeless Buck-Boost PFC Converter	17
2.7	Prototype Circuit for the Proposed BCM Non- Inverting Buck Boost PFC Converter	19
3.1	Flow chart of planning/procedure for the project	21
3.2	Phasor diagram of power factor	22
3.3	The Schematic of a buck–boost converter	23
3.4	The buck-boost operation	24
3.5	Input circuit of AC/DC switch power supply	25
3.6	Input equivalent electric circuit of AC/DC switching power supply	25
3.7	An Ac-Dc Buck Boost Converter by using PID controller (close loop feedback	27
4.1	An Ac-Dc circuit without Power Factor Correction circuit	29

4.2	The input voltage (250V) and the input current.(without PFC)	29
4.3	The voltage output. (without PFC)	30
4.4	The active (P=KW) and reactive power (Q=KVAr). (without PFC)	30
4.5	The power factor. (without PFC)	31
4.6	An Ac-Dc signal open loop Buck Boost Converter	32
4.7	The input voltage (250V) and the input current.(open-loop circuit)	32
4.8	The voltage output. (open-loop circuit)	33
4.9	The active (P=KW) and reactive power (Q=KVAr). (open-loop circuit)	33
4.10	The power factor. (open-loop circuit)	34
4.11	An Ac-Dc Buck Boost Converter by using PID controller (close loop feedback)	35
4.12	The input voltage (250V) and the input current.(closed-loop circuit)	35
4.13	The voltage output.(closed-loop circuit)	36
4.14	The active (P=KW) and reactive power (Q=KVAr). (closed-loop circuit)	36
4.15	The power factor.(closed-loop circuit)	37



**LIST OF TABLES**

3.1	PID parameter	26
4.1	Power factors of circuit without PFC circuits under different loads.	31
4.2	Power factors of Ac-Dc signal open loop Buck Boost Converter	34
4.3	Power factors of Ac-Dc Buck Boost Converter by using PID controller (close loop feedback)	37

**LIST OF SYMBOLS AND ABBREVIATIONS**

ac	Alternating current
dc	Direct current
PFC	Power Factor Correction
PID	Proportional-integral-derivative
K <sub>p</sub>	Proportional gain
K <sub>i</sub>	Integral gain
K <sub>d</sub>	Derivative gain
EMI	Electromagnetic Interference
S1	Switch 1
L	Inductant
D	Diode
C	Capacitor
V <sub>in</sub>	Voltage input
V <sub>out</sub>	Voltage output
kW	Useful power
kVA	Total power
kVar	Magnetic power
P	Active power
Q	Reactive power
pf	Power factor
v	Voltage
D	Duty cycle
CCM	Continuous current mode
DCM	Discontinuous current mode
MOSFET	Metal Oxide Semiconductor Field Effect Transistor

IGBT	Insulated Gate Bipolar Transistor
IACMC	Inductor Average Current Mode Control
BBC	Buck-Boost Converter
BCM	Boundary-conduction-mode
THD	Total harmonic distortion

## CHAPTER 1

### INTRODUCTION

#### 1.1 Project Overview

In the last years, the number and power level of power electronic converters in both industrial and household applications have been significantly increased. In many cases, these applications perform ac to dc conversion, whose classical solutions uses simple diode bridge rectifiers and large dc link capacitors. According to Vitor (2001), such rectifiers produce a large amount of harmonics in the input currents, leading to harmonic distortion and causing poor input effective power factor and source voltage disturbances. Switching the power supplies is widely used to reduce the input-current harmonic distortion. Buck, boost, and buck boost are the three basic switching power supply topologies in common use.

Boost converter is a conventional PFC circuit since its input current can be programmed to follow the input voltage. Boost converter has a small EMI filter due to its continuous input current and a simple circuit. The basic requirement is that the output voltage must be higher than the input voltage. For a wide range output voltage, as in this application, the converter outputs lower voltage, below the input voltage, when the system operates at low power level. Unfortunately, a Boost converter would not be able to accomplish this function. Therefore, in order to achieve high power factor for this operation condition, a Buck converter or the converter which has Buck function has to be used (Yiqing Zhao, 1998).

According to Everett Rogers, 1999, the buck-boost is a popular nonisolated, inverting power stage topology. The buck-boost converter is commonly applied to Power Factor Corrections applications and it is one type of AC-DC converter which is either for step up or step up-step down respectively. Therefore, it is sometimes called as a step-up/down power stage. Power supply designers choose the buck-boost power stage because the output voltage is inverted from the input voltage, and the output voltage can be either higher or lower than the input voltage. Figure 1.1 shows the Buck-Boost PFC Circuit while Figure 1.2 shows the Buck Boost operation.

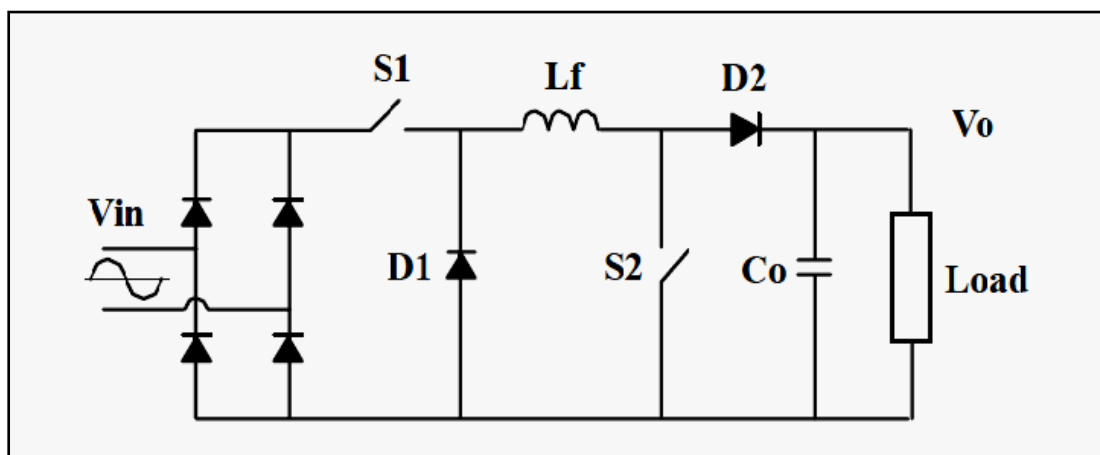

**Figure 1.1:** The Buck Boost PFC Circuit

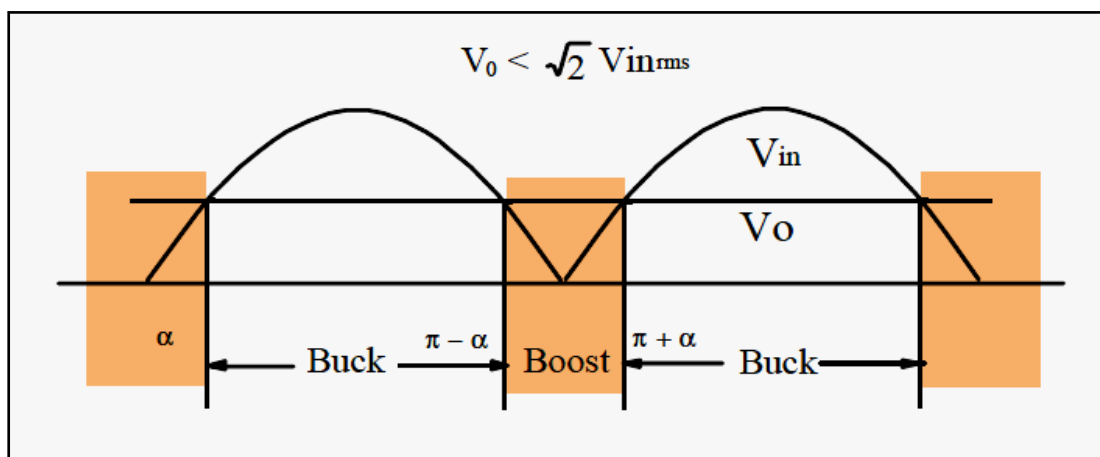

**Figure 1.2:** Buck Boost Operation

## **1.2 Problem Statements**

With the increasing demand for power from the ac line and more stringent limits for power quality, power factor correction has gained great attention in recent years. A variety of circuit topologies and control methods have been developed for the PFC application. One of the biggest problems in power quality aspects is the harmonic contents in the electrical system. Most of the current harmonics are due to the nonlinear operation of the power converters and are furnaces.

By applying a correct power factor correction (PFC), the power consumption is reduced to improve energy efficiency. Reduced power consumption means less greenhouse gas emissions and fossil fuel depletion by power stations. Reduction of electricity bills, reduction of power losses in transformers and distribution equipment are also the benefits of applying the correct PFC. Besides, the equipment life are extended due to the lessen of the electrical burden on cables and electrical components. With the problems occurred and the benefits gained by reason of the power factor correction, an ac-dc buck-boost power factor correction is proposed in this project.

## **1.3 Objectives of Project**

This project has been developed to enhance the achievement in the following matters:

- a) To develop modelling of AC-DC Buck-Boost Converter.
- b) To implement the simulation of AC-DC Buck-Boost Power Factor Correction using the MATLAB simulink software.

#### **1.4 Scope Of Project**

The scope of project has been determined in order to achieve the objective of this project. This project are to get high power efficiency at the rated load current. The development of the AC-DC Buck-Boost Power Factor Correction design and the implementation of the simulation are using the MATLAB simulink software

## **CHAPTER 2**

### **LITERATURE REVIEW**

#### **2.1 Theories**

Theories are important in projects that need to be developed. A theory presents a systematic way understanding events, behaviours and/or situations. A theory is a set of interrelated concepts, definitions, and propositions that explained or predicts events or situations by specifying relations among variables. (Glanz K et al, 2008). There are combinations of theories used in this project. They are theories of Power Factor, Buck Boost Converter, and AC-DC Converter.

##### **2.1.1 Introduction of Power Factor**

In the paper of Power Factor Correction by John Ware (2006), it was stated that the power factor is the ratio between the useful (true) power (kW) to the total (apparent) power (kVA) consumed by an item of a.c. electrical equipment or a complete electrical installation. It is a measure of how efficiently electrical power is converted into useful work output. The ideal power factor is unity, or one. Anything less than one means that extra power is required to achieve the actual task at hand. The power factor can be expressed in two ways;



- a) Power factor (pf) = Useful power (kW) divided by the total power (kVA),
- b) Power factor (pf) = The cosine of the angle between useful power and total power =  $\cos \phi$ .

Figure 2.1 below shows the phaser diagram of kW, kVA and kVAr.

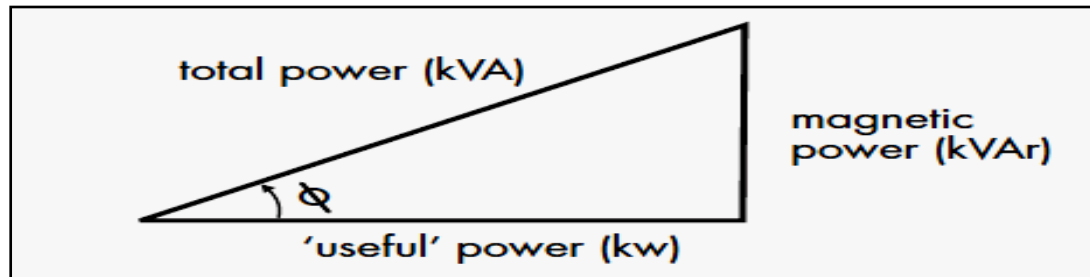

**Figure 2.1** : Phasor Diagram of KW, KVA, KVAr

The phasor diagram above can be translated to the formula as below.

$$\begin{aligned}
 P.F &= \frac{\text{useful power (kw)}}{\text{total power (kVA)}} \\
 &= \frac{p}{V_{rms} \times I_{rms}}
 \end{aligned}$$

### 2.1.2 Introduction of Buck Boost Converter

In continuous conduction mode, the buck-boost converter assumes two states per switching cycle. The ON State is when transistor (mosfet or IGBT) is ON and diode is in OPEN circuit mode. The OFF State is when transistor (mosfet or IGBT) is OFF and diode is CLOSE circuit mode. A simple linear circuit can represent each of the two states where the switches in the circuit are replaced by their equivalent circuit during each state. The circuit diagram for each of the two states is shown in figure 2.2.

The duration of the ON state is  $D \times T_S = T_{ON}$  where  $D$  is the duty cycle, set by the control circuit, expressed as a ratio of the switch ON time to the time of one complete switching cycle,  $T_S$ . The duration of the OFF state is called  $TOFF$ . Since there are only two states per switching cycle for continuous conduction mode,  $TOFF$  is equal to  $(1-D) \times T_S$ . The quantity  $(1-D)$  is sometimes called  $D'$ . These times are shown along with the waveforms in figure 2.2.

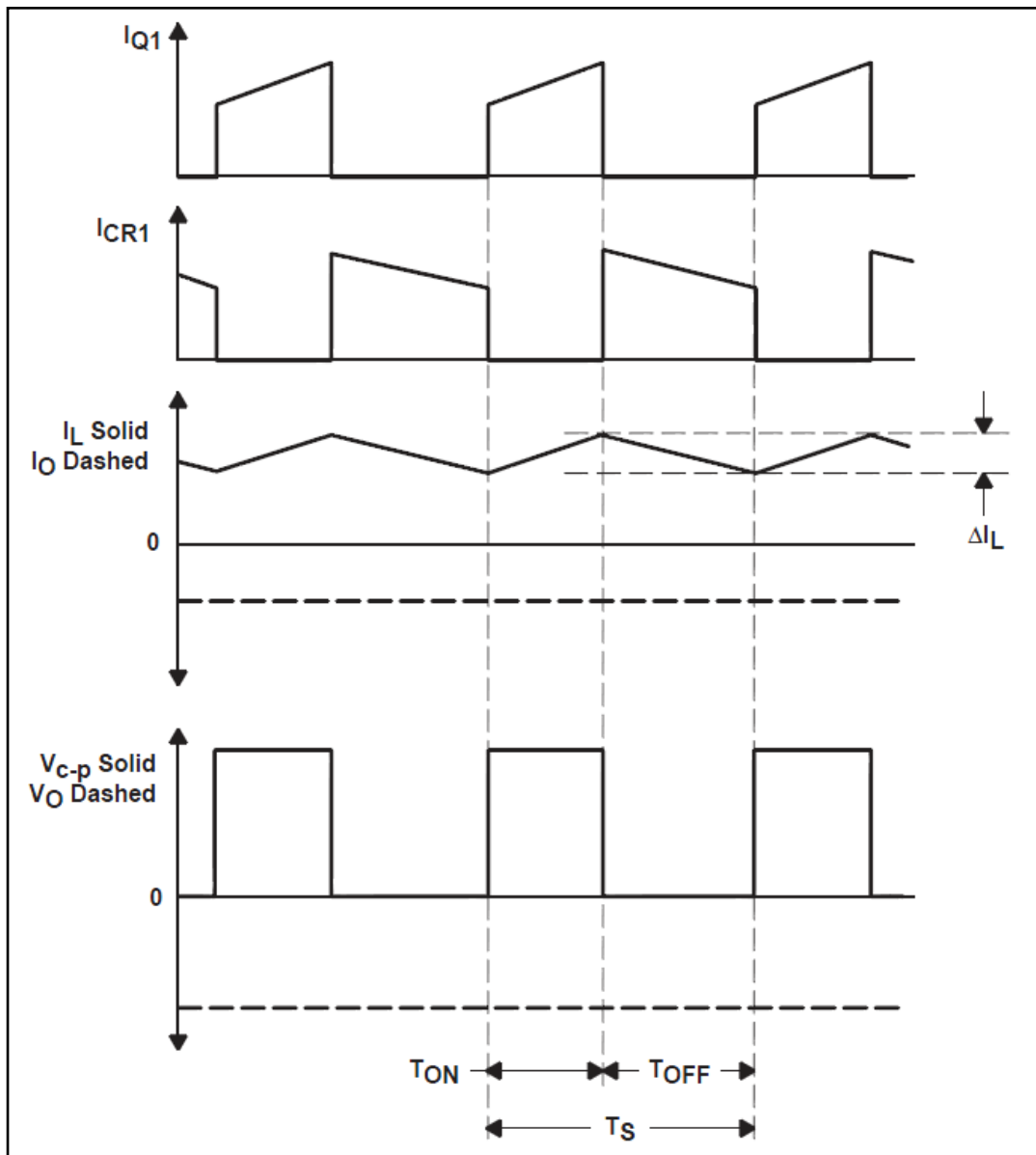

**Figure 2.2:** Continuous Mode Buck-Boost Power Stage Waveforms

### 2.1.2.1 Buck-Boost Converter Formula

The equivalent circuit for buck-boost converter in two switching modes; closed and opened is shown in figure 2.3.

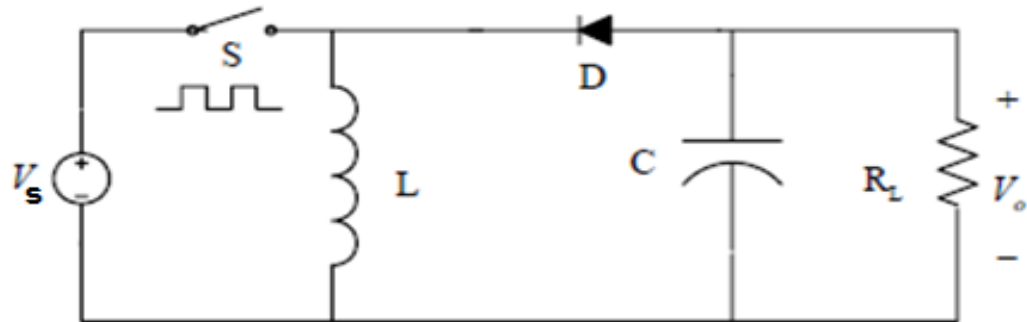

(a)

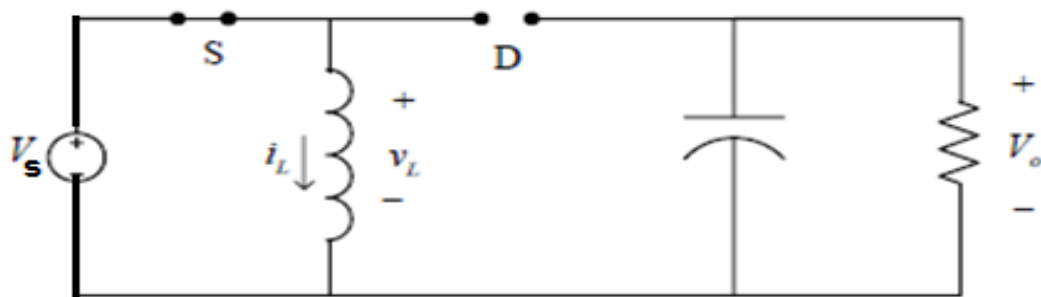

(b)

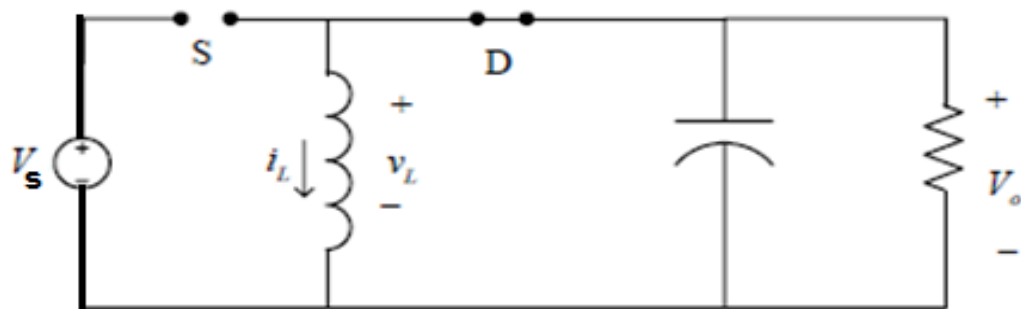

(c)

**Figure 2.3:** Buck-Boost converter (a) Basic Circuit (b) Circuit when switch is closed (c) Circuit when switch is opened

Buck-boost analysis when the switch is closed;

$$V_L = V_s = L \frac{\partial i_L}{\partial t} \quad (2.1)$$

$$\frac{\partial i_L}{\partial t} = \frac{V_s}{L} \quad (2.2)$$

The rate of change for the inductor current is a linearly constant, so equation 2.2 can be expressed as

$$\begin{aligned} \frac{\Delta i_L}{\Delta t} &= \frac{\Delta i_L}{DT} = \frac{V_s}{L} \\ \therefore \Delta i_{L(\text{closed})} &= \frac{V_s DT}{L} \end{aligned} \quad (2.3)$$

Buck-boost analysis when the switch is opened;

$$V_L = V_o = L \frac{\partial i_L}{\partial t} \quad (2.4)$$

$$\frac{\partial i_L}{\partial t} = \frac{V_o}{L} \quad (2.5)$$

The rate of change for inductor current is constant, thus the change in current at opened circuit is

$$\begin{aligned} \frac{\Delta i_L}{\Delta t} &= \frac{\Delta i_L}{(1-D)T} = \frac{V_o}{L} \\ \Delta i_{L(\text{opened})} &= \frac{V_o(1-D)T}{L} \end{aligned} \quad (2.6)$$

For steady-state operation, the net change in inductor current must be zero over one period of time. Voltage output can be determining using equation 2.3 and 2.6 in steady state operation.

$$\Delta i_{L(closed)} + \Delta i_{L(opened)} = 0$$

$$\frac{V_S D T}{L} + \frac{V_O (1 - D) T}{L} = 0$$

Solving for  $V_{out}$

$$V_O = -V_S \left[ \frac{D}{1 - D} \right] \quad (2.7)$$

Equation 2.7 shows the output voltage produced using buck-boost converter method has an opposite polarity compared to input voltage. These converter can produced three stage of voltage depend on the duty cycle;

- i. If the duty cycle is greater than 0.5 ( $D > 0.5$ ), the output voltage will be higher than the input voltage (boost mode).
- ii. If the duty cycle is equal to 0.5 ( $D = 0.5$ ), the output will produce the same amount of voltage as input voltage.
- iii. If the duty cycle is lower than 0.5 ( $D < 0.5$ ), the output voltage will be lower than the input voltage (buck mode).

In the buck-boost converter, the source is never connected directly to the load. Energy is stored in the inductor when the switch is closed and transferred to the load when the switch is opened. Hence, the buck boost converter is also referred to as an indirect converter.

Assuming no power losses in the converter, power absorbed by the load must be equal with power supplied by the source,

$$P_O = P_S \quad (2.8)$$

$$\frac{V_o^2}{R} = V_S I_S \quad (2.9)$$

Average source current is related to average inductor current as;

$$I_S = I_L D \quad (2.10)$$

Thus, equation 2.9 can be written as;

$$\frac{V_o^2}{R} = V_S I_L D \quad (2.11)$$

Solving for  $I_L$

$$I_L = \frac{V_o^2}{V_S R D} = \frac{P_o}{V_S D} = \frac{V_S D}{R(1-D)^2} \quad (2.12)$$

For continuous current mode  $I_L$  must be greater than  $\Delta i_L$

Maximum and minimum inductor current;

$$I_{max} = I_L + \frac{\Delta i_L}{2} = \frac{V_S D}{R(1-D)^2} + \frac{V_S D T}{2L} \quad (2.13)$$

$$I_{min} = I_L - \frac{\Delta i_L}{2} = \frac{V_S D}{R(1-D)^2} - \frac{V_S D T}{2L} \quad (2.14)$$

For continuous current, the inductor current must remain positive. Therefore, in order to determine the boundary between continuous (CCM) and discontinuous current (DCM),  $I_{min}$  in equation 2.14 is set to zero.

$$\frac{V_S D}{R(1-D)^2} - \frac{V_S D T}{2L} = 0$$

Thus, the value of the inductor that determines the boundary between the CCM and DCM is

$$L_{min} = \frac{(1 - D)^2 R}{2f} \quad (2.15)$$

The output voltage ripple for the buck boost converter;

$$|\Delta Q| = \left[ \frac{V_o}{R} \right] DT = C \Delta V_o \quad (2.16)$$

Solving for  $\Delta V_o$

$$\Delta V_o = \frac{V_o DT}{RC} = \frac{V_o D}{RCf} \quad (2.17)$$

Thus

$$r = \frac{\Delta V_o}{V_o} = \frac{D}{RCf} \quad (2.18)$$

### 2.1.3 Introduction of AC-DC Converter

There are two basic types of electricity: alternating current (AC) and direct current (DC). AC stands for Alternating Current, a type of electricity that change constantly from one polarity to another (like what we get from the wall outlets). AC switches directions dozens of times every second, going from negative to positive and back again. Power plants produce alternating current or AC electricity. This electricity is sent through the power grid into houses, businesses and other buildings. Home appliances are designed to use AC, since AC flows into the home. DC stands for Direct Current, a type of electricity that maintains its polarity all the time (like what we get from a battery). DC, by contrast, always flows in the same direction. Batteries, solar panels and certain other power sources use DC electricity. AN AC/DC converter is something that turns outlet-type electricity into battery type electricity.

#### 2.1.4 Introduction to PID controller

*Proportional-integral-derivative (PID) control:* Over 90% of the controllers in operation today are PID controllers (or at least some form of PID controller like a P or PI controller). This approach is often viewed as simple, reliable, and easy to understand.

Typical steps for designing a PID controller are;

- i. Determine what characteristics of the system need to be improved
- ii. Use  $K_P$  to decrease the rise time.
- iii. Use  $K_D$  to reduce the overshoot and settling time.
- iv. Use  $K_I$  to eliminate the steady-state error.

Conventional PID controllers have been extensively used in industry, due to their effectiveness for linear systems, ease of design and inexpensive cost. Despite their effectiveness for linear systems, conventional PID controllers are not suitable for nonlinear systems and higher-ordered and time-delayed systems, not to mention complex and vague systems that require expert knowledge. For these reasons, it is worth developing fuzzy-logic-based controllers which have the capability to handle not only linear, as well as indistinct defined systems.

#### 2.1.5 Introduction to switching (Power semiconductor device)

The range of power devices developed over the last few decades can be represented as a in figure 2.4 on the basis of their controllability and other dominant features.



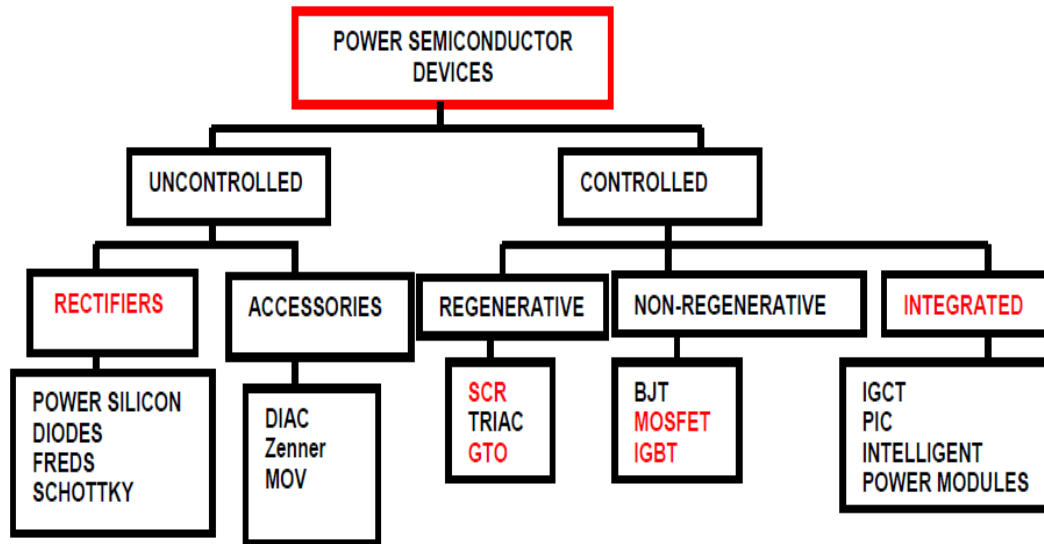

**Figure 2.4:** Power semiconductor device variety

In designing buck-boost converter, converter with non-regenerative power semiconductor component is selected to be a switching device. Most of buck-boost converter designed only used either mosfet or igbt nowadays.

#### 2.1.5.1 MOSFET (*Metal Oxide Semiconductor Field Effect Transistor*)

The Power MOSFET technology has mostly reached maturity and is the most popular device for lighting ballast type of application where high switching frequencies are desired but operating voltages are low. For low frequency applications, where the currents drawn by the equivalent capacitances across its terminals are small, it can also be driven directly by integrated circuits. At high current low voltage applications the MOSFET offers best conduction voltage specifications as the internal resistance is current rating dependent. However, the inferior features of the inherent anti-parallel diode and its higher conduction losses at power frequencies and voltage levels restrict its wider application.

### 2.1.5.2 IGBT (*Insulated Gate Bipolar Transistor*)

It is a voltage controlled four-layer device with the advantages of the MOSFET driver and the Bipolar Main terminal. The switching times can be controlled by suitably shaping the drive signal. This gives the IGBT a number of advantages: it does not require protective circuits, it can be connected in parallel without difficulty, and series connection is possible without snubbers. The IGBT is presently one of the most popular devices in view of its wide ratings, switching speed of about 100 KHz, an easy voltage drive and a square safe operating area devoid of a second breakdown region.

## 2.2 Description of Previous Case Study

At this section, three previous case studies are described. The case studies are “Inductor Average Current Mode Control For Single Phase Power Factor Correction Buck Boost Converter”, “A Novel Bridgeless Buck Boost PFC Converter” and “Non-inverting Buck-Boost Power Factor Correction Converter with Wide Input-Voltage-Range Applications”.

### 2.2.1 Inductor Average Current Mode Control For Single Phase Power Factor Correction Buck Boost Converter

In the paper title “Inductor Average Current Mode Control For Single Phase Power Factor Correction Buck Boost Converter written by D.Jayahar and Dr.R.Ranihemamalini, Inductor Average Current Mode Control (IACMC) is proposed to regulate single phase Power Factor Correction (PFC) Buck-Boost Converter (BBC) operated in Continuous Conduction Mode (CCM). IACMC is typically a two loop control method (inner loop, current; outer loop, voltage) for power electronic converters. The IACMC is used at inner loop to regulate the input current and harmonics, which has the advantages over the peak current and hysteresis current controllers such as the robustness when there are large variations in line voltage and output load. The Proportional-Integral (PI) controller is

implemented at outer loop, which produce the excellence performance of output voltage regulation for BBC under different conditions.

The PI controller is developed by using state space average model of BBC. The single phase PFC BBC with proposed controllers is shown in Figure 2.5 below. In this paper, Matlab/Simulink is used to do the simulation of the proposed system with its control. The simulation results show a nearly unity power factor can be attained and there is almost no change in power factor when the line frequency is at various ranges. The writers made a conclusion that IACMC is advantageous compared to peak current mode controller in the application when the line frequency is changing largely. Besides, the proposed technique offers definite benefits over the conventional boost converter and it is easy to understand, is easy to implement, and draws sinusoidal input current from AC source for any DC output voltage condition. They suggested that, the hardware should be developed in the future, to study further about the PFC BBC with proposed controlled.

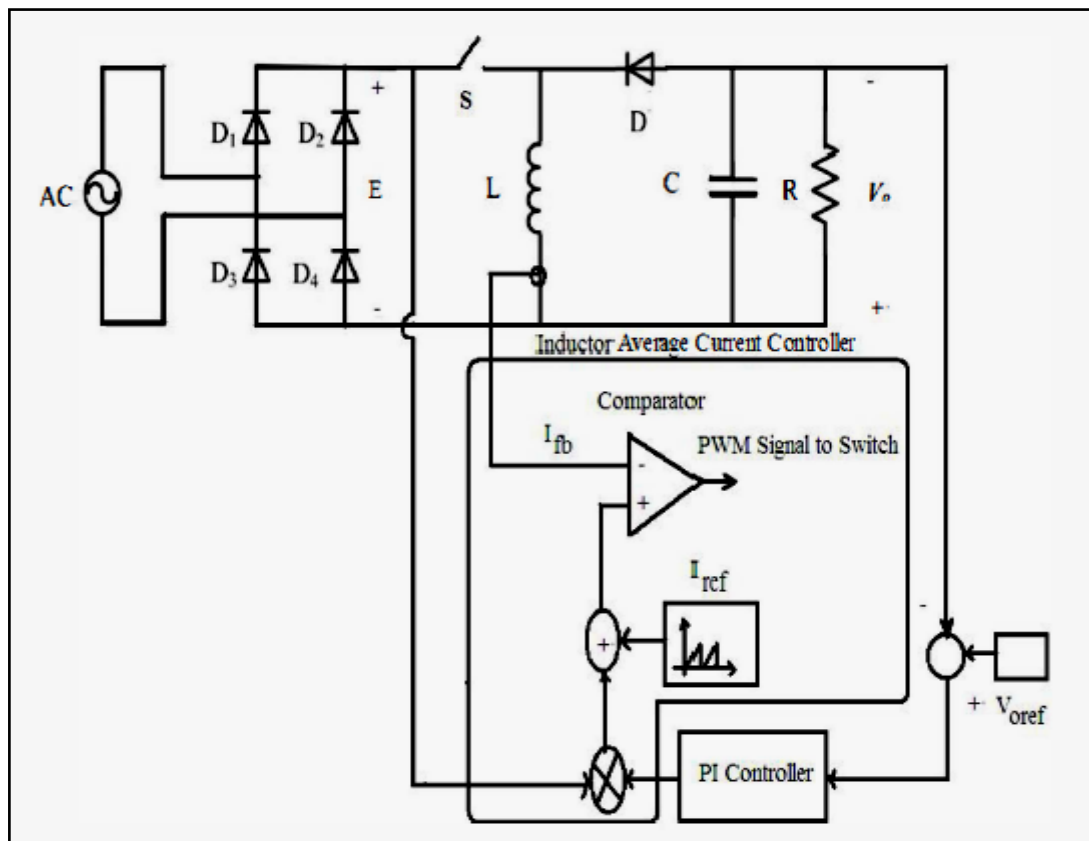
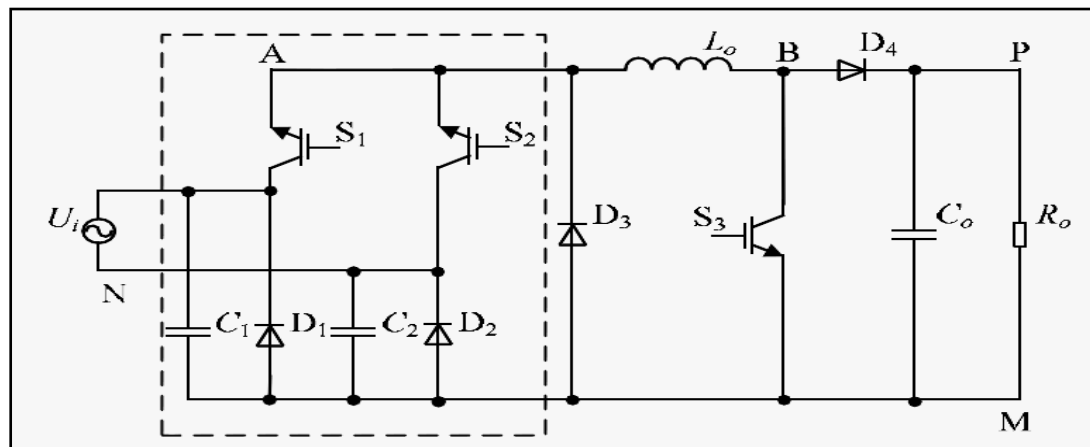

**Figure 2.5:** PFC BBC with Inductor Average Current Controller and PI Controller

### 2.2.2 A Novel Bridgeless Buck Boost PFC Converter

This paper was written in 2007 and the writers of this paper are Wang Wei, Liu Hongpeng, Jiang Shigong and Xu Dianguo from the Harbin Institute of Technology, China. A novel bridgeless buck-boost PFC topology is proposed in this paper. This proposal is to resolve the problem of Conventional Cascade buck-boost PFC (CBB-PFC) converter suffers from the high conduction loss in the input rectifier bridge. The proposed PFC converter (as shown in Figure 2.6) which removes the input rectifier bridge has three conduction semiconductors at every moment. The proposed topology reduces the conduction semiconductors, reduces conduction losses effectively, and improves the efficiency of converter compared to CBB-PFC topology.

This is because CBB-PFC converter consists of bridge rectifier and buck boost converter, and has four conduction semiconductors at every moment. Thus, with the increase of power rating, the conduction loss of converter will increase rapidly. The novel bridgeless buck boost PFC topology is also suitable for use in the wide input voltage range. In this paper, the average current mode control was implemented with UC3854, the theoretical analysis and design of detection circuits was presented. They built an experimental prototype with 400V/600W output and line input voltage range from 220VAC to 380VAC. The experimental results show that the proposed converter can improve 0.8% efficiency comparing CBB-PFC converter.



**Figure 2.6:** Proposed Bridgeless Buck-Boost PFC Converter

### 2.2.3 Non-inverting Buck-Boost Power Factor Correction Converter with Wide Input-Voltage-Range Applications

Written by Ray-Lee and Rui-Che Wang in 2009, this paper presents a non-inverting buck-boost based power-factor correction (PFC) converter operating in the boundary-conduction-mode (BCM) for the wide input-voltage-range applications. Unlike other conventional PFC converters, the proposed non-inverting buck-boost based PFC converter has both step-up and step-down conversion functionalities to provide positive DC output-voltage. It is the combination of a buck converter and a boost converter. This converter has both step-up and step-down conversion functionalities to provide positive DC output-voltage. It is the combination of a buck converter and a boost converter. This converter operates in the buck or boost mode, which is dependent on the level of the instantaneous input voltage  $V_{in}(t)$ . When the level of the instantaneous input voltage  $V_{in}(t)$  is higher than the DC output voltage  $V_0$ , the converter operates in the buck mode; otherwise the converter operates in the boost mode. However, the BCM non-inverting buck-boost PFC converter with the buck boost mode cannot be used to achieve high power factor, which is caused by the constant on-time of BCM. There is increment of the inductor-current during the on time in the buck and boost mode and the instantaneous values of the incremental are different. Therefore, these differences at the transitions between the modes cause the distortion on the inductor current. In order to reduce the turn-on switching-loss in high frequency applications, the BCM current control is employed to achieve zero current turn-on for the power switches. It is operated in the buck-boost mode to eliminate the distorted inductor current.

This paper also included the relationships of the power factor versus the voltage conversion ratio between the BCM boost PFC converter and the proposed BCM non-inverting buck-boost PFC converter. Through the simulation by Matlab/Simulink and some calculation involved, obviously, the effects of the voltage conversion ratio on the power factor and THD of the proposed BCM non-inverting buck-boost PFC converter are much smaller than the BCM boost PFC converter. Finally, the 70-watt prototype circuit of the proposed BCM buck-boost based PFC converter is built for the verification of the high frequency and wide input voltage-range. This prototype incorporated a PFC controller L6562 and a high-

side gate driver IR2117 as shown in Figure 2.7. The measured results meet the IEC 61000-3-2 Class D Standard. With the low input line-voltage (90 Vrms), the PF is 0.99; the THD is 8% and the efficiency is 90% while with the high input line-voltage (264Vrms) the PF is 0.98; the THD is 14% and the efficiency is 91%.

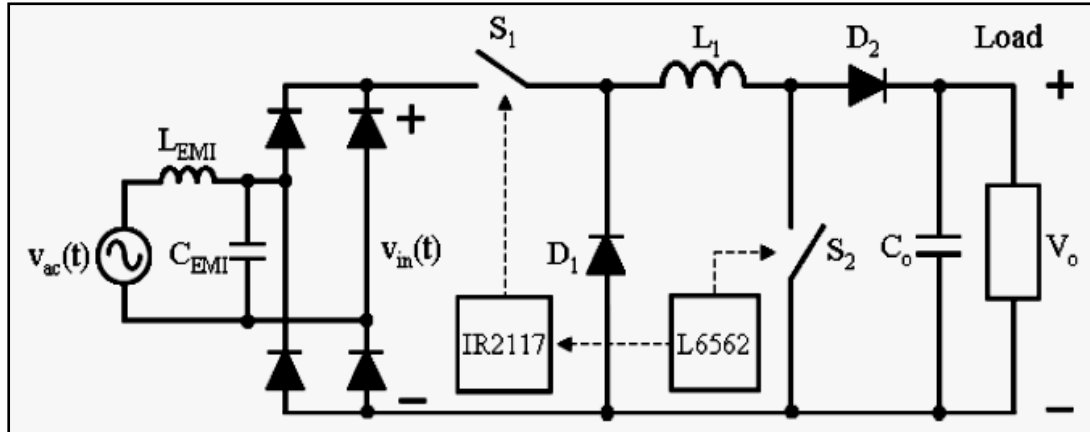

**Figure 2.7:** Prototype Circuit for the Proposed BCM Non-Inverting Buck Boost PFC Converter

### 2.3 Conclusion

This chapter is important to all project development. This is because, this chapter includes theories involved in the project development. It also includes case studies which has been research by other researchers that related to this project. Both theories and case studies will act as guidance and the initiator for the researcher to develop the project. As in this chapter, those three case studies described involved Power Factor Correction, Buck-Boost Converter and AC-DC Converter which are so much related to this project development.

## **CHAPTER 3**

### **METHODOLOGY**

#### **3.1 Introduction**

The focus of this chapter is to provide further details of methodology and approaches to completing this research. This chapter discusses on three main parts, which is designing An Ac-Dc circuit without Power Factor Correction (PFC) circuit, An Ac-Dc signal open loop Buck Boost Converter and An Ac-Dc Buck Boost Converter by using PID controller (close loop feedback). MATLAB R2009b simulink is use to achieve the objective of the research.

The comprehensive planning of this project is shown in figure 3.1. The flowchart of this project was begin by doing some research and observation based on the previous research especially the information related with the applications of Buck Boost converter and power factor correction. The next stage is to do the simulation of the load circuit with an ac/dc power supply by using Matlab Simulink software. After that, the next stage is the simulation of Ac-Dc signal open loop Buck Boost Converter programming. Finally, the simulation of Ac-Dc Buck Boost Converter by using PID controller (close loop feedback). The power factor of this converter is analyzed in term of active and reactive power.

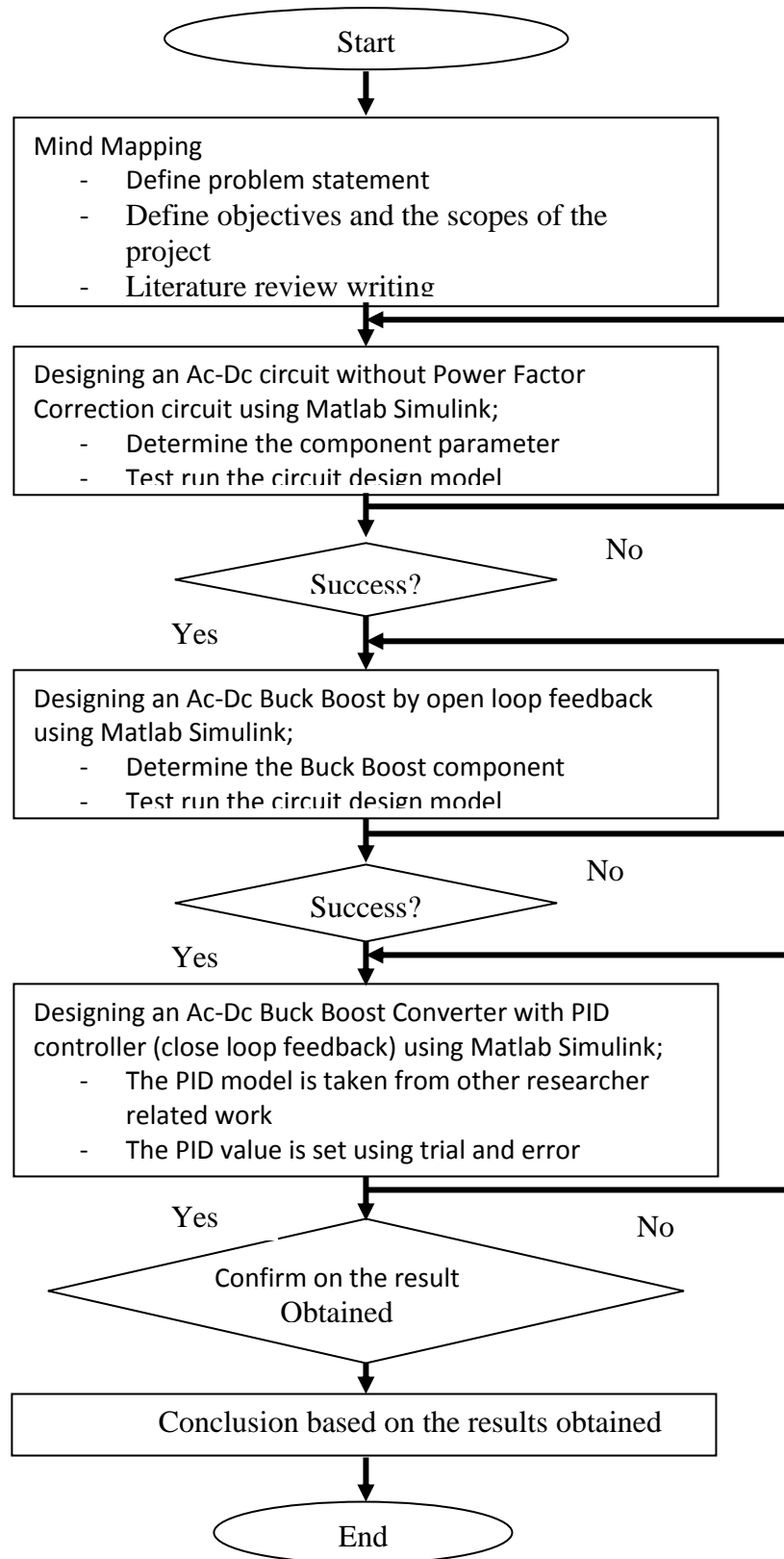

**Figure 3.1:** Flow chart of planning/procedure for the project



### 3.2 Power Factor

In most modern electrical distribution systems, the predominant loads are resistive and inductive. Resistive loads are incandescent lighting and resistance heating. Inductive loads are A.C. Motors, induction furnaces, transformers and ballast -type lighting. Inductive loads require two kinds of power: (1) active (or working) power to perform the work (motion) and (2) reactive power to create and maintain electro-magnetic fields. The vector sum of the active power and reactive power make up the total (or apparent) power used. This is the power generated by the utility for the user to perform a given amount of work.

- Active power is measured in KW (1000 Watts)
- Reactive power is measured in kVAR (1000 Volt-Amperes Reactive)
- Total Power is measured in KVA (1000 Volt-Amperes)

Power factor then is the ratio of active power to total power. We can illustrate these relationships by means of a right triangle. (See Figure 3.2)

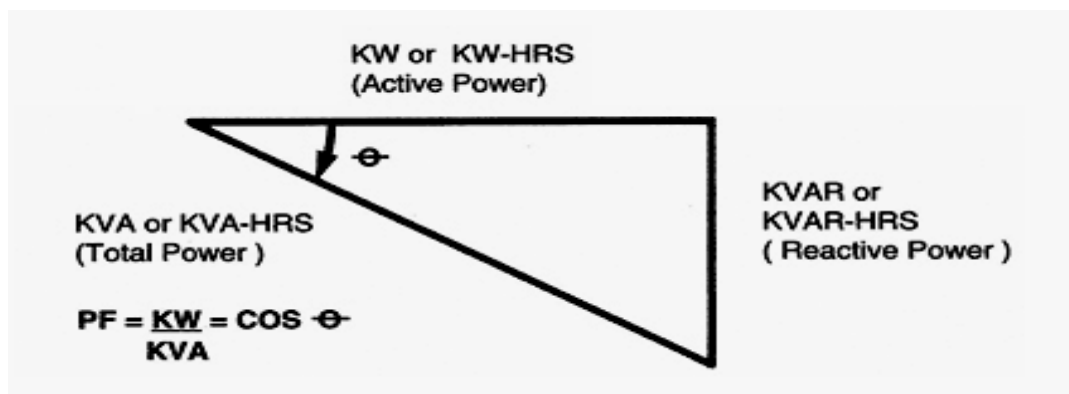
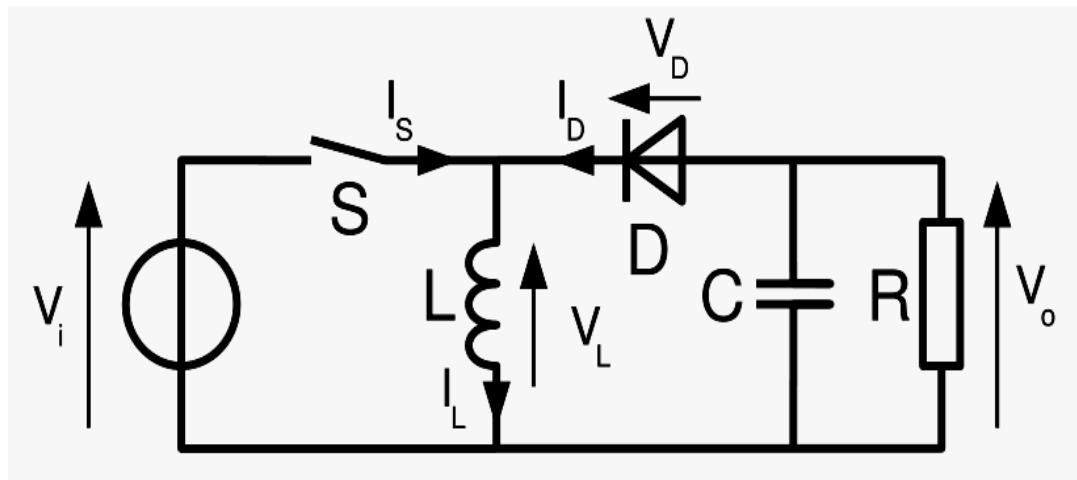

**Figure 3.2:** Phasor diagram of power factor

Note that a low power factor requires a larger amount of KVA to accomplish a fixed amount of work (KW), whereas a high power factor would require a lesser amount of KVA to accomplish the same amount of work. Utilities provide the KVA to the user, and by means of continuous metering, they bill the user each month, and provide actual values of the components of power shown in Figure 3.2. If the values shown on the bill indicate a low power factor, many utilities will add a penalty to the

bill. In like manner, a high power factor may result in a reduction in the over-all cost of total power consumed.

### 3.3 Buck-boost converter circuit



**Figure 3.3:** The Schematic of a buck–boost converter

The buck–boost converter is a type of DC-to-DC converter that has an output voltage magnitude that is either greater than or less than the input voltage magnitude. Two different topologies are called *buck–boost converter*. Both of them can produce a range of output voltages, from an output voltage much larger (in absolute magnitude) than the input voltage, down to almost zero.

#### **The inverting topology:**

The output voltage is of the opposite polarity as the input. This is a switched-mode power supply with a similar circuit topology to the boost converter and the buck converter. The output voltage is adjustable based on the duty cycle of the switching transistor. One possible drawback of this converter is that the switch does not have a terminal at ground; this complicates the driving circuitry. Neither drawback is of any consequence if the power supply is isolated from the load circuit

(if, for example, the supply is a battery) as the supply and diode polarity can simply be reversed. The switch can be on either the ground side or the supply side.

**Principle of operation:**

The basic principle of the buck–boost converter is fairly simple (see figure 3.4):

- 1) While in the On-state, the input voltage source is directly connected to the inductor (L). This results in accumulating energy in L. In this stage, the capacitor supplies energy to the output load.
- 2) While in the Off-state, the inductor is connected to the output load and capacitor, so energy is transferred from L to C and R.

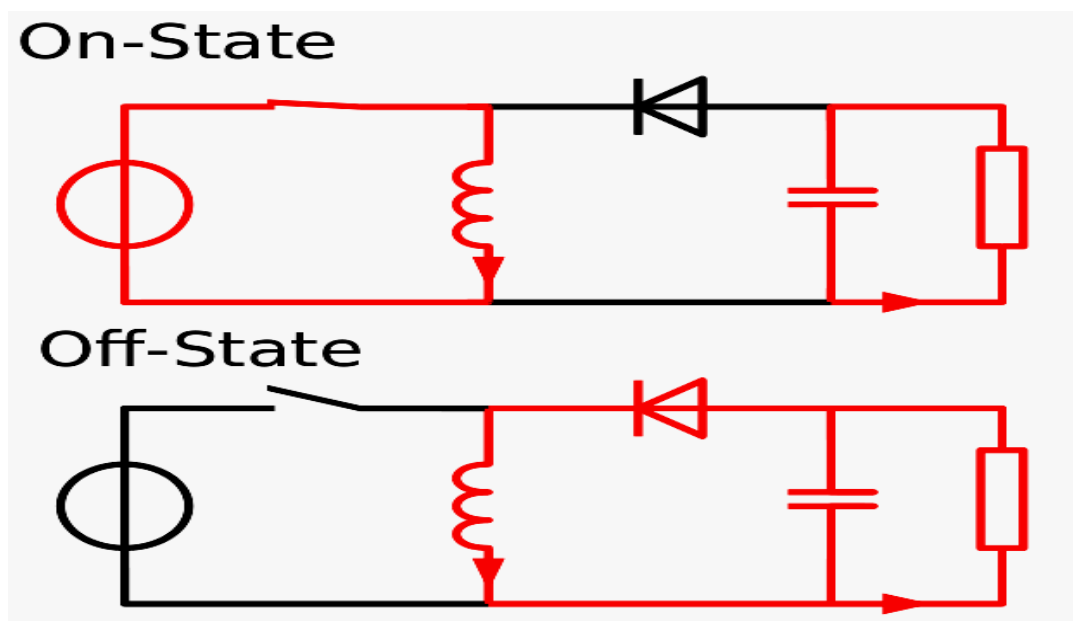

**Figure 3.4:** The buck-boost operation

**3.4 Ac/Dc Switching Power Supply**

Single-phase AC/DC switching power replaces the low frequency transformer of traditional power source with high frequency transformer, so it has such advantages as light weight, small size, and high power density etc. At the

## REFERENCES

- Beams, D. and Boppana, S. (2010). "Modelling and Simulation of Off-Line Boost Power Factor Correction Circuits." USA : University Of Texas at Tyler.
- Choi, B., Hong, S., and Park, H. (2000) "Modeling and small- signal analysis of controlled on-time boost power factor correction circuit." Proceedings of the Third International Power Electronics and Motion Control Conference, pp. 490-495.
- Everett Rogers. (1999). "Understanding Buck-Boost Stages in Switchmode Power Supplies." *SLVA059*.pp 1-32.
- Glanz K, Rimer BK, Viswanath K. (2008). "Health Behavior and Health Education: Theory, Research, and Practice (4th ed). San Francisco: Jossey-Bass.
- Jayahar, D. And Dr, Ranihemamalini, R. (2011). "Inductor Average Current Mode Control For Single Phase Power Factor Correction Buck Boost Converter." Chennai, India: St. Peters Engineering College.
- John Ware. (2006). "Power Factor Correction." *IEE Wiring Matters*.pp 22-24.
- Lin Luo, Fang. (2005). "Single Stage Power Factor Correction AC/DC Converter." Singapore :Nanyang Technological University.

- Mahmoud Shaker, A, Ass. Prof. Dr. M. Salleh, A. and Prof. Dr. S. Ismail, Kais (2008). "Design and Simulation of Power Factor Correction for AC/DC Converter." Iraq :Baghdad and Al Nahrin University.
- Moschopoulos, G. and Zheng, Y. (2006). "Buck-Boost Type AC/DC Single Stage Converter." London, Ontario, Canada: University of Western Ontario.
- Muhammad H. Rashid, (2004): *Power Electronics Circuits, Devices, and Applications*'' Electrical computer Engineering University of west Florida.
- Ping, L., Yu, M., Yong, K., Hui, Z., and Jian, C.(1999), "Analysis of single-phase boost power-factor correction (PFC) converter." Hong Kong : Proceedings of the 1999 IEEE International Conference on Power Electronics and Drive Systems.
- Ray Lee, Lin. and Rui Che, Wang. (2010). "Non-inverting Buck-Boost Power Factor Correction Converter with Wide Input Voltage Range Applications." Tainan City, Taiwan :National Cheng Kung University.
- Robert W. Erickson, "DC-DC Power Converters" Wiley Encyclopedia of Electrical and Electronics Engineering, 2007.
- Tahami, F., Gholami, B., and Amadhian, H., (ISIE 2008) "Modeling of the boost power-factor correction rectifier in mixed conduction mode using PWA approximation." Proceedings of the 2008 IEEE International Symposium on Industrial Electronics, pp. 254-258.
- Vitor Fernao Pires and Jose Fernando A. Silva (2001). "Single Stage Three-Phas Buck-Boost Type AC/DC Converter With High Power Factor." Portugal: Centro University Tecnica de Lisboa..
- Wang Wei, Liu Hongpeng, Jiang Shigong and Xu Dianguo. (2008). "A Novel Bridgeless Buck Boost PFC Converter." Harbin, China: Harbin Institute of Technology.

Yiqing Zhao. (1998). "Single Phase Power Factor Correction Circuit With Wide Output Voltage Range." Blackburg, Virginia: Virginia Polytechnic Institute and State University.