

NASA CR-132852

N 7 4 1 0 9 6 5

WGRC 73-3273
Copy 3 of 65 Copies

IMAGE DATA PROCESSING SYSTEM REQUIREMENTS STUDY

Volume I
Analysis

T. Honikman
E. McMahon
E. Miller
L. Pietrzak
W. Yorsz
General Research Corporation
Washington Operations
1501 Wilson Boulevard
Arlington, Virginia 22209

**CASE FILE
COPY**

October 1973
Final Report for Period March-August 1973

Prepared for
GODDARD SPACE FLIGHT CENTER
Greenbelt, Maryland 20771

This work was performed under contract NAS-5-21920
with Goddard Space Flight Center, Greenbelt, Md. 20771

TECHNICAL REPORT STANDARD TITLE PAGE

1. Report No. CR-1-417	2. Government Accession No.	3. Recipient's Catalog No.	
4. Title and Subtitle Image Data Processing System Requirements Study, Volume I, Analysis		5. Report Date October 1973	
		6. Performing Organization Code	
7. Author(s) T. Honikman, E. McMahon, E. Miller, L. Pietrzak, W. Yorsz		8. Performing Organization Report No. CR-1-417	
9. Performing Organization Name and Address General Research Corporation Washington Operations 1501 Wilson Boulevard Arlington, Virginia 22209		10. Work Unit No.	
		11. Contract or Grant No. NAS-5-21920	
12. Sponsoring Agency Name and Address Goddard Space Flight Center Greenbelt, Maryland 20771 John Y. Sos, NASA Monitor		13. Type of Report and Period Covered Final Technical Report May 1973-August 1973	
		14. Sponsoring Agency Code	
15. Supplementary Notes			
16. Abstract Digital image processing, image recorders, high-density digital data recorders, and data system element processing for use in an Earth Resources Survey image data processing system are studied. Loading to various ERS systems is also estimated by simulation.			
17. Key Words (Selected by Author(s)) Earth Resources Survey System Digital Image Processing High-Density Digital Data Recorders Mission Simulation		18. Distribution Statement	
19. Security Classif. (of this report) Unclassified	20. Security Classif. (of this page) Unclassified	21. No. of Pages viii + 153	22. Price*

PREFACE

OBJECTIVES

The primary objective of this study was to investigate Image Data Processing requirements and system configurations for an operational Earth Resources Survey (ERS) system.

SCOPE

The scope included a definition of Digital Image Processing and Data Systems Element Processing requirements as well as a survey of image recorders and high density digital data recorders. The work was expanded to include a study of the loading (frames per day) into the data processing facility (DPF) using an ERTS-1 simulation model that includes simulated weather forecasts.

CONCLUSIONS AND RECOMMENDATIONS

The following major conclusions were reached:

1. All-digital image processing systems are feasible. The recommended configuration consists of a general purpose digital computer augmented with special purpose digital hardware, an input video tape recorder and interfacing device, high density digital data recorder as the primary output device, and laser beam recorders interfaced to the high density digital data recorder. Demonstrated high-density tape recorders ($\sim 10^6$ bits/in²) and laser beam recorders are presently available.
2. The utility of special purpose hardware increases significantly as the image resampling function (producing data on a regular output grid from a distorted input grid) increases in sophistication.

4. Estimated average loads (frame/day) for various numbers of stations are:

	<u>1 Station</u>	<u>2 Stations</u>	<u>3 Stations</u>
Load to DPF	150	260	350
Actual Data	120	200	260

CONTENTS

<u>SECTION</u>		<u>PAGE</u>
	PREFACE	i
1	INTRODUCTION	1
	1.1 Background	1
	1.2 Summary and Recommendations	2
2	ALL-DIGITAL IMAGE PROCESSING	4
	2.1 Introduction	4
	2.2 Systems Centered About General-Purpose Hardware Exclusively	5
	2.2.1 Data Processing (DP) Estimating Procedures and Assumptions	5
	2.2.2 Data Processing (DP) Estimates	12
	2.2.3 Summary of Results	23
	2.3 Systems Incorporating Special-Purpose Hardware	35
	2.3.1 Introduction	35
	2.3.2 Candidate Special-Purpose Hardware	42
	2.3.3 Candidate Machine Architectural Details	45
	2.3.4 Implementation Estimates	52
	2.3.5 Off-Loading Trade-Off and Results	58
	2.4 Mission Configurations 3, 4 and 5: All-Digital Design Approaches	58
	2.4.1 System Configuration	61
	2.4.2 Input Units	61
	2.4.3 Output Units	63
	2.4.4 Digital Processing Units	65
3	DATA SYSTEMS ELEMENT (DSE) PROCESSING	68
	3.1 Introduction	68
	3.2 Overview of the Goddard DSE	69
	3.3 DSE Computational Subsystem Software	72
	3.3.1 Operational Summary	72
	3.3.2 Master Digital Data (MDD) Generation	84

CONTENTS (Cont.)

<u>SECTION</u>		<u>PAGE</u>
	3.3.3 Image Annotation Generation	89
4.	RECORDER SURVEYS	98
	4.1 Film Recorders	98
	4.1.1 Requirements	98
	4.1.2 Electron Beam Recorders	102
	4.1.3 Laser Beam Recorder	103
	4.1.4 Primary Factors to be Considered in LBR Versus EBR Trade-Off	104
	4.1.5 Manufacturers	104
	4.1.6 Summary of Recommendations	107
	4.2 High-Density Digital Tape Recorders	108
	4.2.1 Archival Storage	108
	4.2.2 Digital Products	114
	4.2.3 Device Description	116
5	DATA LOADING STUDY	135
	5.1 Introduction	135
	5.2 Summary	136
	5.3 Simulation	141
	5.4 Weather Forecast Simulation	143
	5.5 System Constraints	145
	5.6 Geographical Effects	147
	5.7 Fifth-Band MSS Night Operations	151
<u>APPENDIX</u>		
A	SIMULATION OUTPUT FOR ERS LOADING STUDY	(Vol. II)
B	SIMULATION OUTPUT FOR ERS NIGHT TARGET STUDY	

FIGURES

NO.		PAGE
1	Interrelationships Between Major Functions, All-Digital System	11
2	ERTS (ERS) Algorithmic Structure	13
3	Computation Required for Each GCP Correlation	18
4	Mission 3, Low Processing Estimates	24
5	Mission 3, High Processing Estimates	25
6	Mission 4, Low Processing Estimates	26
7	Mission 4, High Processing Estimates	27
8	Mission 5, Low Processing Estimates	28
9	Mission 5, High Processing Estimates	29
10	General-Purpose and Special-Purpose/Host Computer Organizations	37
11	Overview of the XDS Sigma 5 System Configuration	71
12	Present DSE Sigma 5 Core Utilization	78
13	Flow of Data in the BPM/BTM Environment	79
14	Image Annotation Tape Format	92
15	Processing Time vs. P, Two Systems	111
16	Processing Time vs. P, Three Systems	111
17	Effect of Using One and Four Operators	113
18	Effect of Multiple Recorders	113
19	Simulation Results	138
20	World Region Definition by Lagrange Multiplier L1	149

TABLES

NO.		PAGE
1	Estimated Data Processing Load in MIPS for 100 Image Sets per 16-Hour Day	30
2	Estimated Data Processing Load in MIPS for 200 Image Sets per 16-Hour Day	31
3	Estimated Data Processing Load in MIPS for 250 Image Sets per 16-Hour Day	32
4	Estimated Data Processing Load in MIPS for 400 Image Sets per 16-Hour Day	33
5	Summary of System Configuration Requirement	40
6	Summary of Characteristics of Special-Purpose Hardware	46
7	Summary of Estimated Execution Rates for Off-Loaded ERS Functions	59
8	Reduction of Required MIPS Due to Functional Off-Loading	59
9	Load Modules Comprising Existing DSE Software	73
10	Load Modules Comprising Existing DSE Software	74
11	Information Subsystem Major Activities	75f
12	Computational Subsystem Major Activities	77
13	Present DSE Data Base Disc Allocation	80
14	DSE Computation Subsystem: Summary of Computer Resources Required	82
15	Summary of Estimated Processing MIPS	85
16	Estimated Instructions Executed for Major Calculations	90
17	Image Annotation Tape	93f
18	RCA Laser Recorder Characteristics	106
19	Archival Storage Systems	109

TABLES (Cont.)

<u>NO.</u>		<u>PAGE</u>
20	Estimates, Frames/Day, Average	137
21	Simulation Detail	140
22	Night Target-Downlink Conflict Summary	152

1 INTRODUCTION

1.1 BACKGROUND

The Earth Resources Survey (ERS) satellite program is intended to be a fully operational remote sensing system for management of the earth's resources. The system will acquire high resolution multispectral data of the earth's surface which is transmitted to a data processing center located at the Department of Interior, Sioux Falls, South Dakota, for correction and reduction into images or digital tapes to fulfill the varied requirements of investigators and user agencies.

The overall ERS system includes:

1. An Operations Control Center (OCC) which is the focal point of mission orbital operations
2. The satellite itself which carries a payload that includes multispectral sensors (MSS and RBV); wide band video tape recorders, telemetry, tracking and command subsystems, etc.
3. A communications network linked to ground receiving sites that collect the multispectral data
4. A ground Data Processing Facility (DPF) for data correction and reduction

This study focuses on the DPF. Specifically, it investigates requirements and system configurations for a DPF that employs all-digital image processing techniques for the correction of radiometric errors and geometric distortions in the sensor images. Also included is a survey of image recorders and high density digital tape recorders.

The study was conducted over a period of three months during which numerous meetings and personal contacts were made with related technology groups within the NASA Goddard Space Flight Center as well as industry. These groups included: design and operating personnel associated with

the present operational ERTS-1 system at Goddard; technology groups involved in the overall ERS study effort in and outside of Goddard; and some 30 companies producing image and digital tape recorders.

1.2 SUMMARY AND RECOMMENDATIONS

Since specific sections in this report have been written for inclusion in a total ERS study, the major sections contained herein are related primarily in that they address identified topics in an overall ERS system study.

The topics covered are divided into sections as follows:

- Section 2 Digital Image Processing - Data processing algorithms, processor estimating procedures, and general-purpose and special-purpose computer implementations are discussed. Specific requirements for three candidate configurations have been numbered 3, 4, and 5 for consistency with the overall ERS system study.
- Section 3 Data Systems Element Processing - Computer requirements for a data processing facility other than those for direct image processing are derived from the existing ERTS-1 facility and presented here.
- Section 4 Recorder Surveys - Image recorders (laser beam and electron beam recorders) and high-density digital tape recorders (on the order of 10^6 bits/in²) are surveyed for application in an ERS image processing system.
- Section 5 Data Loading Study - Modifications to an existing ERTS-1 simulation system were made to perform simulations for various ERS system configurations. Loading in terms of image sets per day were derived and are reported here. Topics related to operational and command functions (such as number of sensor operations, effect of target geographical distribution) are also addressed. The

computer output from the simulation runs is assembled as a separately bound volume of appendixes.

The primary results of this study are as follows:

- Digital image processing systems are feasible, and the recommended configuration consists of a general-purpose digital computer augmented with special-purpose digital hardware, an input video tape recorder and interfacing device, high density digital tape recorders as the primary output device, and laser beam film recorders interfaced to the high-density digital tape recorders.
- Demonstrated high-density digital tape recorders ($\sim 10^6$ bits/in²) and laser beam recorders are presently available.
- The utility of using special-purpose hardware significantly increases as the image resampling function (producing data on a regular output grid from a distorted input grid of data) increases in sophistication.
- Estimates of computational processing required for the Data Systems Element are within uncertainty limits on estimates of processing required for image processing

It should be noted that the processing estimates and system configurations developed in this study reflect a low to medium scale of detail; it would be expected that additional efforts, at a much higher level of detail, be completed prior to final selection of specific computer systems.

2 ALL-DIGITAL IMAGE PROCESSING

2.1 INTRODUCTION

As contrasted with hybrid electro-optical methods, the all-digital image processing systems correct for radiometric errors and geometric distortions by operating directly on the imagery data in digital form. Simply stated, digital data defining the intensity level of each picture element of a given scene is corrected and adjusted using the various computational and operational procedures described herein. These procedures include the following major functions:

- (1) Image input (including digitization of analog video data)
- (2) Error measurement (both radiometric and geometric)
- (3) Error removal (definition of transformation functions)
- (4) Output (includes video interpolation between known transformation points)

This section is concerned primarily with estimating the computer resources required to perform these major functions and also to establish preliminary system configurations for Missions 3, 4, and 5. In addition the estimating procedure, including assumptions and limitations, is reviewed. It should be noted that the resulting estimates and system designs reflect a low to medium scale of detail; it would be expected that additional efforts, at a much higher level of detail, be completed prior to final selection of specific computer systems.

The system configurations studied involve (1) the use of a large-scale, general-purpose digital computer system, and (2) the combination of a large- or medium-scale general-purpose machine with special-purpose hardware. Each of these is discussed separately in secs. 2.2 and 2.3 respectively, with a summary of the final system configurations presented in sec. 2.4.

2.2 SYSTEMS CENTERED ABOUT GENERAL-PURPOSE HARDWARE EXCLUSIVELY

2.2.1 Data Processing (DP) Estimating Procedures and Assumptions

Developing accurate requirements for a system which is underspecified requires consideration of a number of factors under a variety of assumptions. In the present situation, the objective is to derive overall DP requirements which represent reasonable estimates based on the types and amounts of data and on the intrinsic nature of the algorithm which must be applied to the data in order to provide the desired results. Underlying this estimating process are several operational assumptions and loading requirements that affect the context of the resulting estimates; these are discussed below.

A Estimating Procedure

The estimating procedure discussed here assumes that the all-digital system is centered around a general-purpose digital computer with appropriate memory, input, output, and peripheral devices. However, it is recognized that an important alternative to a general-purpose system is to "off load" certain of the image processing functions to special-purpose computer hardware; this would be done, for example, to reduce the overall cost of the all-digital computing complex and/or to increase the capacity to process images in specific ways at the same or a lesser cost. This alternative is addressed in sec. 2.3.

The general-purpose processor is assumed to have an infinite local memory and also a typical complement of instructions, all of which operate in strictly serial fashion. Thus, algorithms implemented on this processor have execution times which are directly related to the overall instruction counts incurred by the algorithm. The DP estimates can therefore be expressed in terms of "standard instruction executions." A "standard instruction" is (roughly speaking) the equivalent of a machine language instruction of the form: fixed-point add from memory to a register and leave the results in the register. Other instruction executions

can be quantified in relation to this "standard instruction" based on general characteristics of typical computer systems and/or on measures of their relative degree of difficulty (with respect to a computer executing the instruction). For example, a multiply instruction typically counts as two "standard instructions," and a divide instruction counts as four "standard instructions."

Once details of the algorithms to be executed have been itemized, the numbers of required "standard instructions" can be estimated. Since large numbers are normally required, these computing loads are expressed in millions of instructions. In turn, these values can be referred to time (based on the deadline requirements inferred from the scene-based workload to be discussed shortly), and expressed in terms of Millions of Instructions Per Second, or MIPS. These MIPS curves provide specific estimates of the required data processor power as a function of the system loading.

Estimates of required memory can be made independent of the estimates of required processor "power," provided that (1) the actual computer system is relatively insensitive to the assumption of infinite memory, and (2) the actual computer system has "sufficient" internal storage to support execution of the algorithms. In the present case, the relatively ordered form of the information (i.e., scenes) allows complete separation of memory size from processor capacity.

In addition to estimates of processor capability and memory, the actual machine must have sufficient I/O capacity to support the estimated data exchange rates. As with estimates of processor memory size, estimates of required peripheral capacity can be uncoupled from processor estimates provided that there is sufficient capacity in actual machines. Transfer rates on typical computer systems are only a weak function of processor activity, since these operations are overlapped with processor functions.

Hence, estimates of peripheral capacity are unimportant in regard to processor estimates so long as there is a capability for multiplexing system I/O and processor use. In other words, with current computer architectures it is generally possible to replicate I/O capacity without excessive interference with processor capacity.

B Mission Requirements and Assumptions

The principal factors which impact the processing load for the all-digital system are the following:

- The scene-based workload, i.e., the number of scenes per day, and the data characteristics of a given scene.
- The specific algorithms chosen as providing a balance between accuracy requirements and data processor size

The appropriate commingling of these two factors requires insightful engineering judgment if the data processing estimates are to be reasonable ones. While the former factor--the number of scenes per day--is largely a system design feature that is somewhat constrained, the latter factors, involving the selection of the algorithms to be used in processing each scene, exhibit great leverage with respect to the amount of "computing power" required.

(1) Scene-Based Workload

A "scene" is a collection of band-limited frames of information from either the RBV (return beam vidicon) or the MSS (multi-spectral scanner) sensor covering 100 n mi \times 100 n mi area on the ground. Depending on the mission configuration, each scene consists of 6 to 9 frames. The contents of each frame is an array of picture elements (pixels) each of which is the encoded measured intensity from the sensor for some range of frequencies. Each pixel is encoded to 64 levels of grayness and is represented as a 6-bit quantity. However, radiometric calibration may require 8 bits to maintain accuracy.

The following assumed scene parameters and arrival rates from the basis of the data processing estimates:

Scene Arrival Rates:

As low as 25 scenes/day to as high as 400 scenes/day. This range covers the system requirements of Missions 3, 4, and 5.

RBV Scene Data:

Each RBV scene is assumed to consist of various numbers of panchromatic frames. Each frame is assumed to be 4096×4096 pixels in size. The number of RBV frames, for each of the three mission options are:

- Mission 3: 1 frame/scene
- Mission 4: 4 frames/scene
- Mission 5: 6 frames/scene

MSS Scene Data:

Each MSS scene is assumed to consist of four basic frames; each frame is assumed to be 3000×2600 pixels in size. In addition, there is a fifth MSS frame with lower resolution; this frame is assumed to be $1/3 (3000 \times 2600)$ pixels in size.

(2) Algorithm Selection

Each frame of each scene must be radiometrically and geometrically correct. That is, each must be adjusted for known deficiencies and variations in the sensor response to impinging intensity sources, and, each must be geometrically transformed so that the resultant image represents a true one. The data on variation in sensor is gathered over a period of time and is assumed to be known explicitly. The information which can be used to generate the necessary transformations of each frame to eliminate geometric distortions can come from three sources:

1. Detailed data about satellite position, attitude, and attitude rates, based on telemetry data and supplementary calculations performed on satellite tracking data

2. Correlation between one frame of the input scene and similar (but independently collected) data corresponding to a ground control point (GCP). (The selection of which of the several frames to employ in this role is assumed to be outside the domain of this study.)
3. A combination of GCP and satellite position and attitude data

For the purposes of this study we assume that GCP techniques are used as the primary means of identification of the appropriate transformation. In any DP estimating activity the greatest concentration is placed on those algorithmic processes which dominate the overall estimates. In the current estimating situation the major functions performed in processing MSS or RBV digital imagery include:

1. Radiometric correction: accounts for drift in sensor sensitivity with time and within each frame.
2. Reseau detection: for RBV imagery detection of existing reseau patterns to support identification of the image transformation due to internal sensor errors.
3. Ground control point correlation: detection of ground control points to support identification of the image transformation due to external positional errors.
4. Inverse transformation generation: use of GCP, attitude, positional, and reseau information to generate specific transformations applied to the input image to produce the corrected scene.
5. Output image generation: use of the transformation and video interpolation to identify the corrected pixel values for the output scene.

Other secondary functions include

1. Input and output control
2. Annotation computation (sec. 3)
3. Internal data management and operating system requirements (sec. 3)

The interrelationships between these major functions are identified in fig. 1.

The detailed reasoning behind the specific algorithm selections to perform these functions is given in subsequent sections. It is important to note here that, for purposes of early estimates, the algorithm selection was focused into two regimes:

1. A "low" level reflecting the minimum acceptable overall error in the corrected scenes.
2. A "high" level reflecting a margin of safety in regard to overall scene fidelity.

The "high" level represents a sufficient quantity of data processing power; the "low" level reflects what would reasonably occur in the most compact implementations possible.

More specifically, the following assumptions were chosen to represent the "high" and "low" processing options.

"High" Options:

1. Reseau detection in the RBV frames is performed by a shadow casting technique in a "search region" of 128×128 pixels.
2. Ground control point correlation in MSS frames is performed on a 128×128 pixel region, within a search area of 256×256 pixels.
3. Video interpolation is performed with bilinear interpolation over the four rectangularly arranged pixels nearest to the interpolant point.

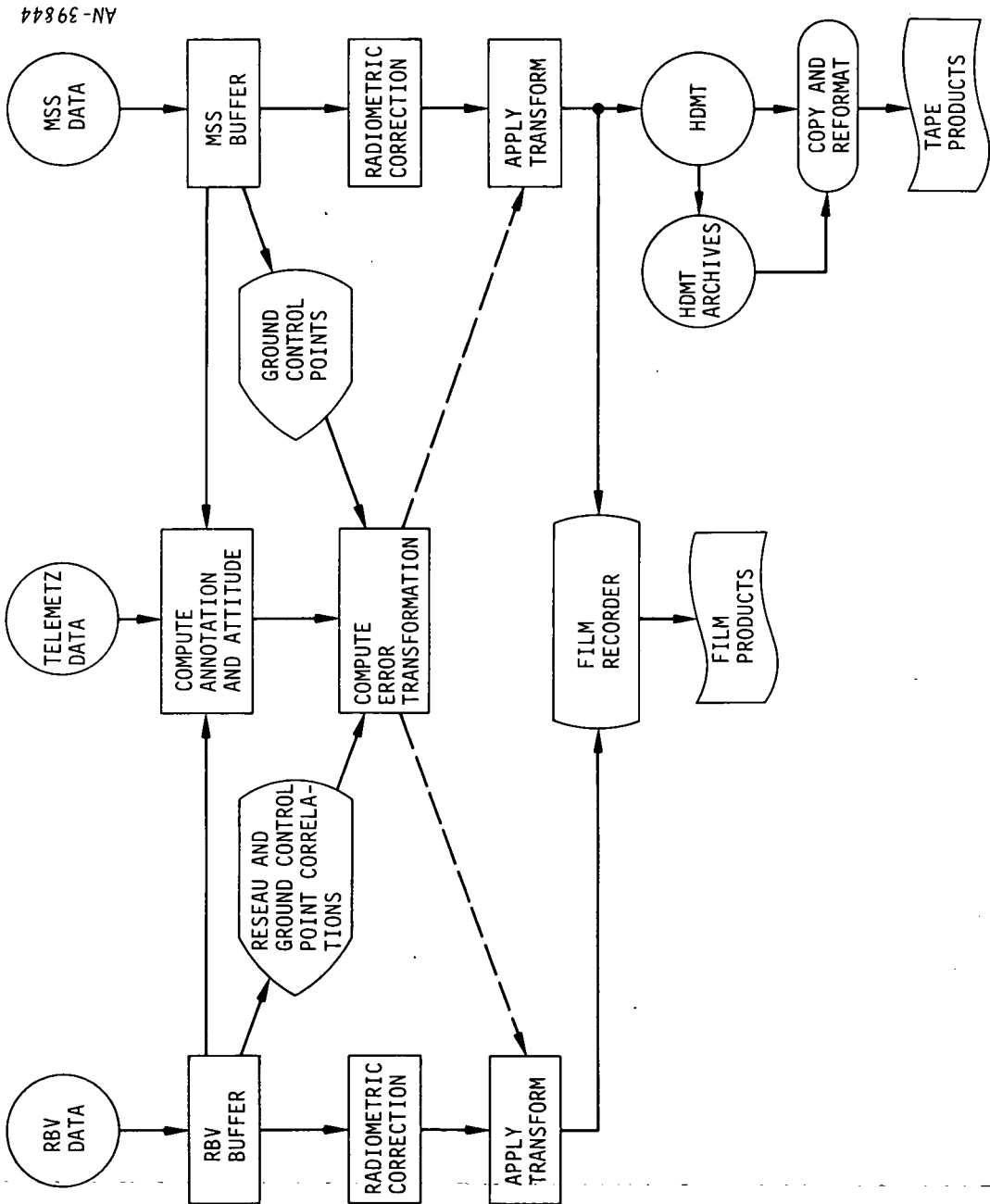

AN-39844

Figure 1. Interrelationships Between Major Functions, All-Digital System

"Low" Options:

1. Reseau detection in the RBV frames is performed by a shadow casting technique in a search region of 32×32 pixels.
2. Ground control point correlation in MSS frames is performed on a 16×16 pixel region, within a search area of 128×128 pixels.
3. Video interpolation is performed by choosing the pixel value of the nearest neighbor to the interpolant point.

2.2.2 Data Processing (DP) Estimates

A Derivation of Estimates

As discussed in the previous section, the major functions to be performed in processing ERS scenes account for the vast majority of the processor burden. These functions are:

- Data input/output and radiometric correction
- Reseau detection
- Ground control point (GCP) correlation
- Inverse transformation generation
- Output video scene determination
- Operating system overhead

Detailed study of algorithms which support each of these major resource consumers has led to estimates of the basic DP requirements summarized in sec. 2.2.3. The remainder of this section is devoted to a detailed description of the major factors which led to those DP requirements. The computer program which guides this sequence of estimations is shown in fig. 2.

B Data I/O and Radiometric Correction

Each frame of each ERS scene must have applied to it a set of radiometric corrections which account for variations in the sensitivity

```

1      PROGRAM ERTS
C      STRUCTURE OF NASA/ERTS ALL-DIGITAL IMAGE PROCESSING FUNCTION.
C      NOTE -- EACH EXPOSURE YIELDS 1 RBV + 1 MSS SCENE
2      WHILE(THERE ARE SCENES TO PROCESS)
3          IF(IMAGE IS RBV)
4              NFRAMES = VARIES WITH SPECIFIC SYSTEM
5              NPOINTS = 4096 * 4096
6              WHILE(1.LE.I.LE.NFRAMES)
7                  INPUT FRAME
8                  RADIOMETRIC CORRECT (TABLE LOOKUP)
9              END WHILE
10             WHILE(1.LE.I.LE.NRESEAU)
11                 PERFORM RESEAU COMPUTATION
12             END WHILE
13             WHILE(1.LE.I.LE.NUMBER OF RBV GROUND CONTROL POINTS)
14                 PERFORM GROUND CONTROL POINT CORRELATION
15             END WHILE
16         ORIF(IMAGE IS MSS)
17             NFRAMES = VARIES WITH SPECIFIC SYSTEM
18             NPOINTS = 3000 * 2600
19             WHILE(1.LE.I.LE.NFRAMES)
20                 INPUT FRAME
21                 RADIOMETRIC CORRECT (TABLE LOOKUP)
22             END WHILE
23             WHILE(1.LE.I.LE.NUMBER OF MSS GROUND CONTROL POINTS)
24                 PERFORM GROUND CONTROL POINT CORRELATION
25             END WHILE
26         END IF
27         COMPUTE INVERSE TRANSFORMATION COEFFICIENTS
28         IDENTIFY GRIDDING
29         WHILE(1.LE.I.LE.NFRAMES)
30             WHILE(1.LE.J.LE.NPOINTS)
31                 DETERMINE INVERSE OF OUTPUT PIXEL IMAGE
32                 INTERPOLATE VIDEO VALUE
33             END WHILE
34         END WHILE
35         OUTPUT CORRECTED SCENE TO FILM RECORDER
36         OUTPUT CORRECTED SCENE TO MAGNETIC TAPE
37     END WHILE
38     END

```

Figure 2. ERTS (ERS) Algorithmic Structure

of the particular sensor. These variations are a function of time, but it is assumed that the corrections to be applied change only relatively slowly as compared with the totality of pixels comprising each scene. That is, we assume that the corrections apply to a relatively large number of pixels.

The simplest technique for applying a correction to 6-bit pixels is a table lookup procedure. In this procedure a 64-position table is provided such that each position contains the "corrected" value for a signal value corresponding to the index into the table. Updating the correction transformation amounts, therefore, to replacement of the contents of this table.

The rate at which the table must be updated is a function of the actual rates of change of sensitivity of the various ERS sensors. Clearly, however, the processor cost for performing the updates is only a small fraction of the cost of applying the transformation to each pixel in the frame. If we assume that the task of retrieving each frame from peripheral storage (rotating memory) and making it available to the central processor is combined with the process of transforming each pixel value according to a fixed location table, then the entire process can be performed at a cost of approximately 2 standard instruction executions per pixel.

C Reseau Detection

Detection of existing reseau patterns for RV images must be performed for as many points as necessary in the reseau to support identification of the appropriate image transformation. The number of standard instruction executions required to identify each reseau pattern can be estimated independently of the number of applications of the procedure. The number of times this identification process is applied can remain as an estimating parameter.

The basic algorithm chosen for reseau detection is a form of the well-known "shadow casting" techniques. We assume that a reseau detection region of $N_R \times N_R$ pixels is known a priori to contain the reseau which is to be located to the nearest pixel position. The shadow casting algorithm requires (1) the addition of pixel intensity values by rows and by columns in this search area, (2) the application of a third-order polynomial at each of $N_R - 10$ locations; the polynomial is made to fit the pixel values at points 5 pixels to the right, 5 pixels to the left, and at the trial reseau location. At each location, the sum of the absolute differences between the polynomial-predicted value and the actual pixel value is computed. After this computation is performed for each of $N_R - 10$ locations, the pixel position displaying the maximum absolute difference value is chosen as the centerpoint of the shadow cast by the reseau. This computation is performed along the two orthogonal axes provided by the uncorrected image pixel locations.

The total number of standard instruction executions required for this algorithm is given by the following formula:

$$912N_R^2 - 9120N_R, \quad N_R \geq 10$$

Typical values of N_R range from $N_R = 32$ to $N_R = 128$. These values account for the maximum uncertainty in reseau location within the given RBV scene.

D Ground Control Point Correlation

A variety of algorithms exists for the identification of the location of a "ground control point" within the uncorrected ERS scene. These algorithms assume that there is a given picture region (the ground control point) which is to be correlated with the actual scene; overall system accuracy is sufficient to permit a priori specification of a "search area" in which the correlating point is known to lie. A simple computation shows that simple correlation techniques consume astronomically large

numbers of standard instruction executions; for example, direct correlation for a 256×256 given region within a 512×512 pixel search area can be shown to require on the order of 10^{10} operations or more! Hence, the development of a good method for quickly and accurately identifying the precise location of a ground control point within a specified search region will be a subject of much detailed investigation and experimentation.

For purposes of estimating the resource consumption of this important step--rather than actually identifying a specific optimum algorithm--we assume that the correlation computation is performed according to a semi-optimum search procedure which has the property that it is of the same degree of difficulty as what could reasonably be expected in an actual data processing situation. The search algorithm we have chosen is a two-dimensional binary search: (1) a series of checks is made of the absolute correlation (absolute difference) between the given picture region and the data within the given search window, (2) after a correlation check is made then the appropriate location for the next correlation check is determined by some means which exactly quarters the uncertainty. For this algorithm the maximum number of correlation computations is a function only of the ratio of the sizes of the search window and the search area.

It is important to note that this algorithm is not necessarily a practical one, since it assumes that after each trial correlation there is a monotonic gradient function which can be evaluated in order to decide the location of the next trial correlation point. The resource consumption properties of this algorithm are not significantly different from those based on Fibonacci or other optimum search strategies.

We assume that the search area is a square region of L_W pixels on a side, and that the region over which the correlation computation is performed is a square M_W pixels on a side. Typical ratios between L_W and M_W range from 1 to 4; this range of values is based on analysis of the maximum uncertainty in the location of the true correlation point.

The number of standard instructions required for this algorithm to execute are given in fig. 3; each curve estimates the required number of instructions per correlated GCP, with the value of the ratio between L_W and M_W treated as a parameter. Naturally, the case where $L_W = M_W$ is equivalent to knowing the point of highest correlation beforehand; we have included this case, however, as a means to illustrate the importance of the contribution of the correlation computation itself, which is clearly dominant. This observation corroborates our belief that heuristic techniques must be applied to the GCP identification operations.

E Inverse Transformation Generation

The GCP information, possibly combined with satellite position, attitude, and attitude rate information developed from other sources, forms the basis for the generation of the specific transformation to be applied to the given scene (the input image) to produce the correct scene (the output image). The transformation chosen must account for all of the systematic errors extant in the input image, so that the output image represents a true rendition of the viewed geographic area. The corrections for radiometric shift have already been performed; what remains is to account for all forms of geometric error.

Previous study efforts by IBM and TRW have pointed out the infeasibility of applying a fully general transformation to each frame of each scene: too much computation is involved in return for the precision a fully general transformation scheme would produce. A more pragmatic approach recognizes the sampled-digital form of the output scene and attempts to provide corrections to within a fraction of an output scene pixel; additional resolution is, for all practical purposes, "swamped" in the discretization "noise." The identification of the appropriate practical techniques for performing this transformation must take into account two major factors:

- . The maximum tolerable error in the output scene
- . The total computation time required

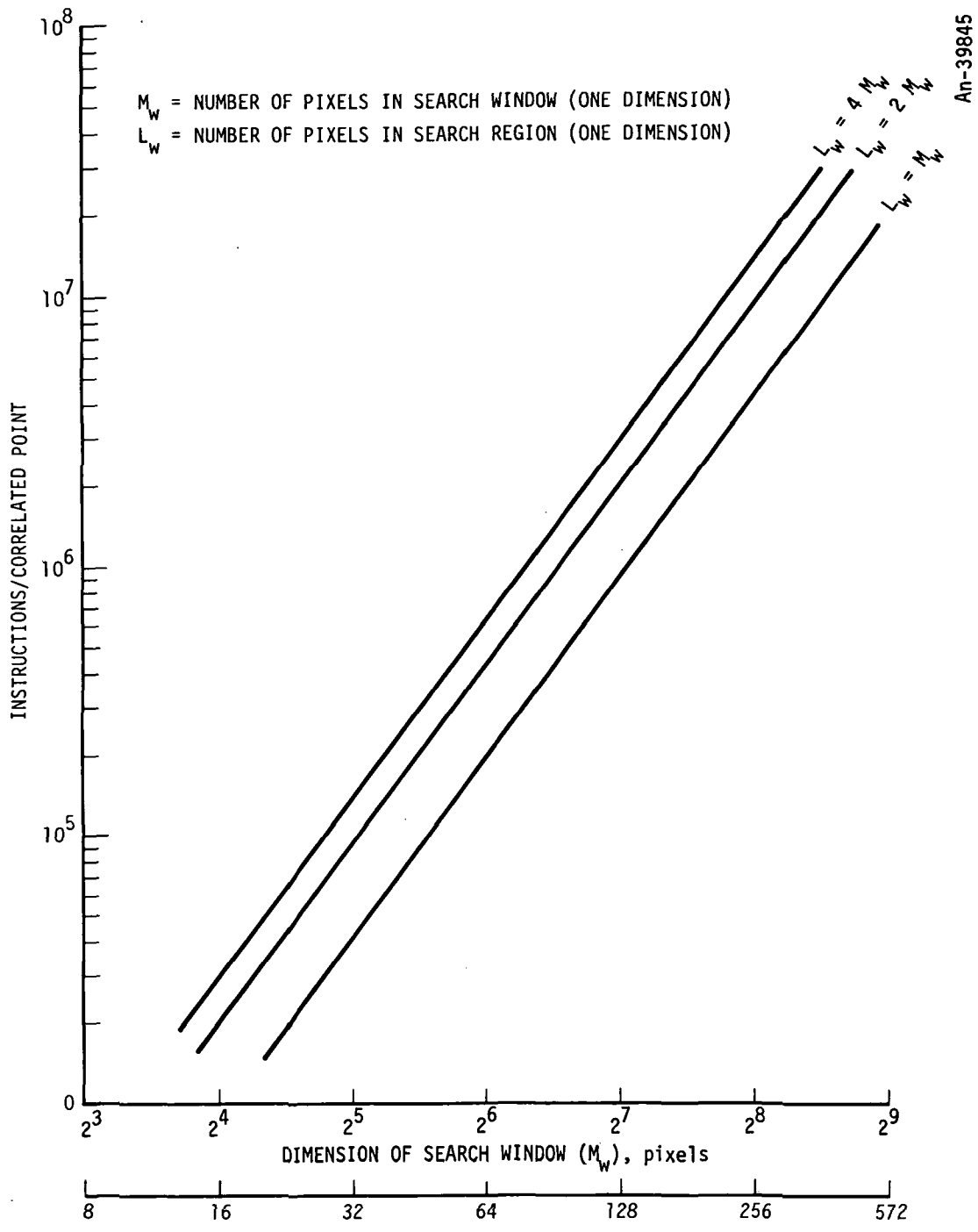

Figure 3. Computation Required for Each GCP Correlation (Binary Search Assumed)

Because the transformation chosen will be applied (in one form or another) to every pixel in the output scene, there is a strong impetus to provide a very fast-running algorithm. Such an algorithm must, of course, assure adherence to acceptable output image error figures.

For estimation purposes it is not necessary to develop a complete algorithm for both generating and applying this image transformation; instead, it is sufficient to identify the principal resource-consuming aspects of this problem in such a way as to assure that the estimates which result are reasonable ones. Clearly, much effort will be devoted to refining the transformation/application process to achieve the fastest possible execution commensurate with the allowable output image precision requirements.

A survey of various techniques of image correction has led to the conclusions that follow:

1. The inverse transformation can be adequately represented as some form of low-order multivariate polynomial transformation. For example, for the MSS data third-order polynomial approximations appear to be sufficient; for the RBV data, fifth-order polynomial approximations appear to be adequate.
2. With such transformations the absolute pixel shift between input and output scene is only a slowly varying function of the pixel location. That is, there are relatively large regions within each image for which the resultant pixel shift will remain at some constant value.

This observation allows the use of gridding techniques to simplify the application of the transformation, and minimizes the number of times the pixel-instantaneous value of the transformation must be evaluated.

On the basis of these observations, then, we can develop standard instruction estimates for the generation of the transformation and (in the next section) its application to the actual data. In fact, because the latter computations dominate rather severely, we introduce the assumptions that follow:

1. The transformation (which involves inverting a relatively small matrix, i.e., on the order of 10×10) can be identified in fewer than 10^6 standard instruction executions.
2. The resulting polynomial coefficients as a basis for identifying appropriate gridding of the input image can be evaluated in fewer than 10^6 standard instruction executions.

Hence, we allow 2×10^6 instruction executions for this phase of the computation.

F Output Image Generation

The gridded transformation values which result from the computations just described must next be applied to each pixel in the input scene to produce the output scene. For each output scene pixel there is a point within the input scene from which the video value would arise; in general, this point will fall within some rectangle of input scene pixel locations. The output video value is the effective value of this point as if it had been sampled by the satellite originally. Because it was not (in general), it is necessary to devise a scheme for interpolating the correct value for the output pixel. Analysis of the region around this interpolation point by, say, high-order polynomial or functional approximation has been found to be unnecessary, as well as too consumptive of DP execution time. Instead, fairly simple techniques are applied to arrive at the correct interpolated pixel value. Two such techniques are:

1. Nearest neighbor approximation. In this method, the output image pixel is taken as being the video value of the input image pixel nearest the interpolation point.

2. Bilinear interpolation. In this method, the video value is calculated to be the value taken on by the surface generated by ortho-linear interpolations between the four most adjacent pixels.

The nearest neighbor approximation is the faster of the two methods, whereas the bilinear interpolation produces somewhat more accurate output image values.

The gridding techniques discussed in the previous section permit significant reductions in the required instruction execution counts for the particular version of video interpolation performed. This occurs because the location of the interpolant points in successive pixel rectangles is relatively constant from rectangle to rectangle; the gridding was chosen in order to make this situation occur. Thus, essentially the same interpolation formula can be applied to relatively large numbers of interpolant points in the same relative position within each successive interpolating rectangle. In the extreme case, when the interpolation technique used is the "nearest neighbor" method, there is the possibility of additional savings by identifying the selection to be made (upper right, lower left, etc.) and applying the selection to all points along the scan or motion axis up to the next grid point. We do not permit this simplification here, however.

Detailed instruction count estimates for the nearest neighbor and the bilinear interpolation schemes yield the following values:

Nearest Neighbor: 2 instruction executions/pixel

Bilinear Interpolation: 12 instruction executions/pixel

It is important to note that these values are the results of conversion of machine instruction sequences into equivalent standard instruction executions.

G Operating System Overhead

All of the foregoing discussion has centered on the requirements of the system to process RBV and MSS data directly. In addition to these processing requirements, it is also important to include estimates for the overhead which is lost to the computer operating system. The value of this operating system overhead is a function of (1) the number of partially completed image processing activities extant in the operating system's work queues at any one instant, and (2) the architecture of the specific input/output system chosen to support the central processor's image processing operations. In other words, the operating system overhead is a function of the "complexity" of the instantaneous data processing task and, therefore, is a direct function of the number of scenes required to be processed each day. There will, in addition, be some minimum overhead requirement which is independent of the number of scenes processed per day; this constant amounts to the penalty paid for providing sufficient data processing capacity for the target load.

Precise estimation of operating system overhead is difficult to perform at this high-level stage of system specification. The following formula represents a reasonable approximation to the operating system overhead expected:

$$N_{\text{overhead}} = N_{\text{idle}} + N_{\text{per scene per day}} \times N_{\text{scenes/day}}$$

We have chosen the following value for the "idle" parameter:

$$N_{\text{idle}} = 0.25 \text{ MIPS}$$

The formula for the amount of overhead as a function of the number of scenes per day is based on the following values:

<u>Number of Image Pairs/Day</u>	<u>N^{per scene} per day</u>
0	0.0
100	0.0001
200	0.0002
300	0.0004
400	0.0010

This semi-quadratic formulation accounts, in addition, for the increased overhead which results from the greater interference likely to be encountered when the per day scene loading is relatively large. This set of values was used to produce the summary estimates given in sec. 2.2.3.

2.2.3 Summary of Results

Based on the procedures and assumptions outlined in sec. 2.2.1 and also the detailed estimates presented in sec. 2.2.2, data processing requirements as a function of the number of scenes per day are presented in figs. 4-9 and tables 1-4.

Figures 4 and 5 summarize graphically the low and high processing load estimates as a function of image sets per day for Mission 3; figs. 6 and 7 for Mission 4; and figs. 8 and 9 for Mission 5. These figures were plotted from the detailed data presented in tables 1-4 which break down the processing load for each basic function as they vary according to Mission, sensor, and low and high estimate. More specifically table 1 presents MIPS required for 100 image sets per day, table 2 for 200, table 3 for 250, and table 4 for 400.

These estimates are based on searching for all points in the reseau, using GCPs from every frame, and not reprocessing any data.

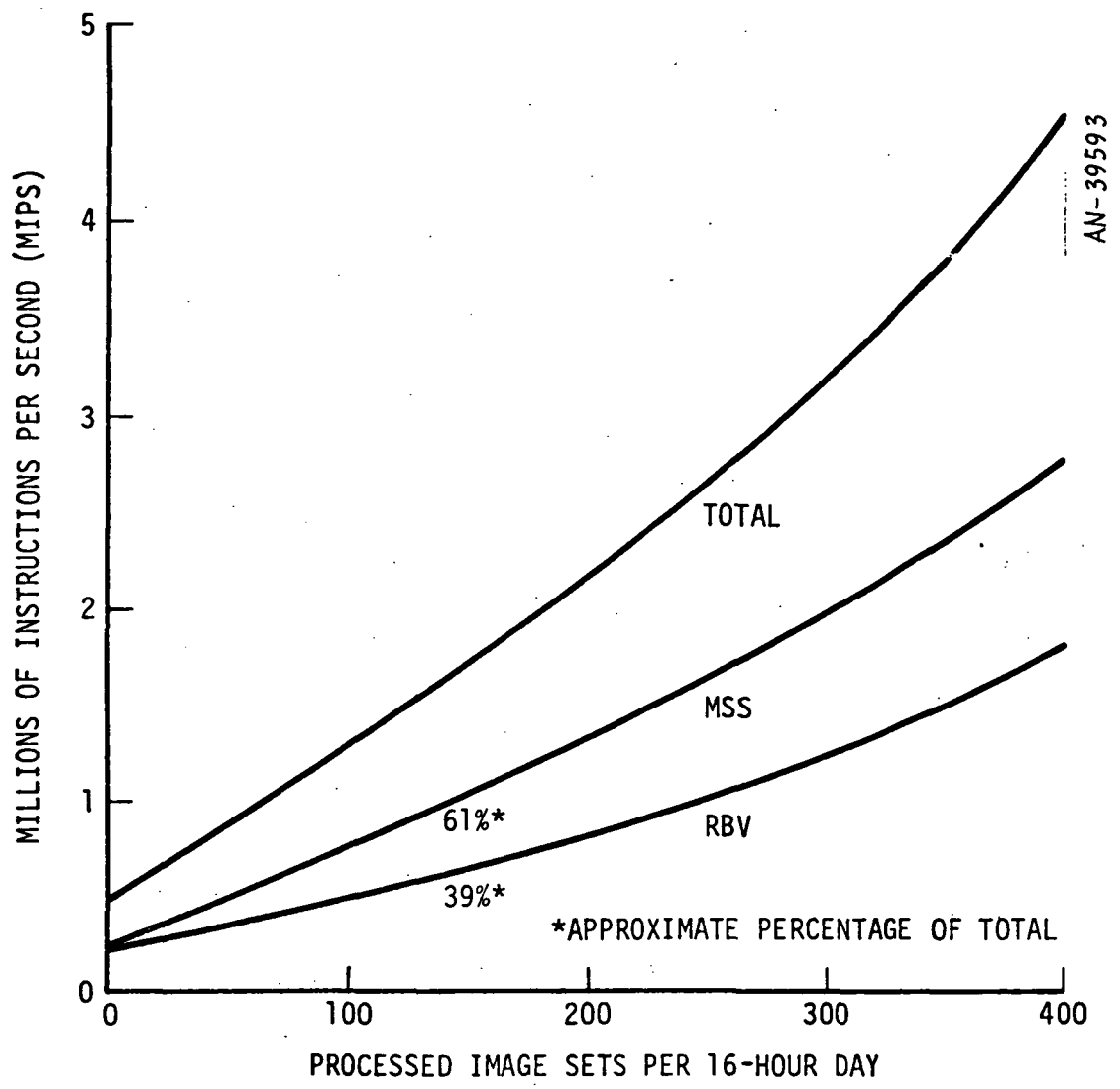

Figure 4. Mission 3, Low Processing Estimates

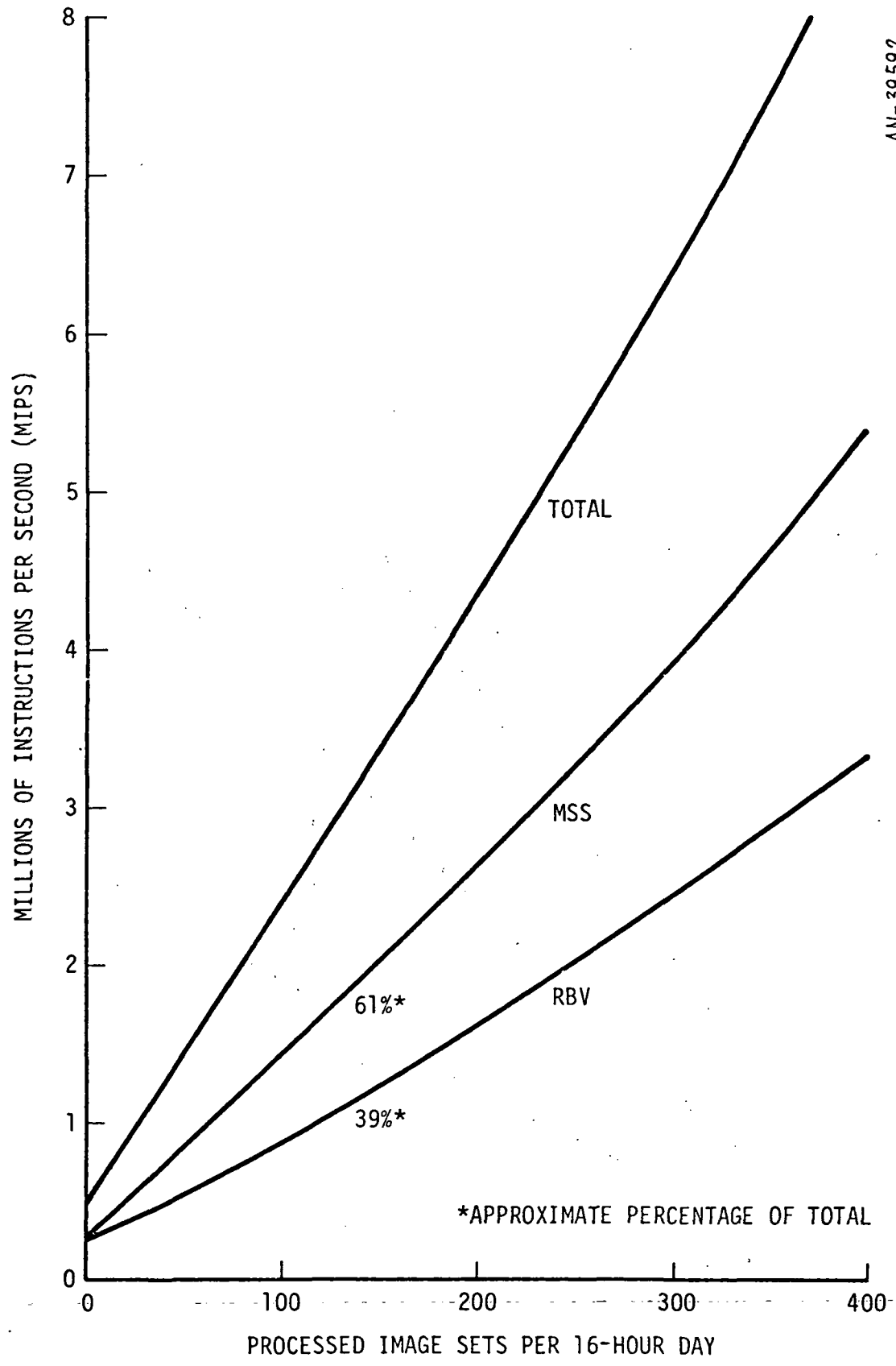

Figure 5. Mission 3, High Processing Estimates

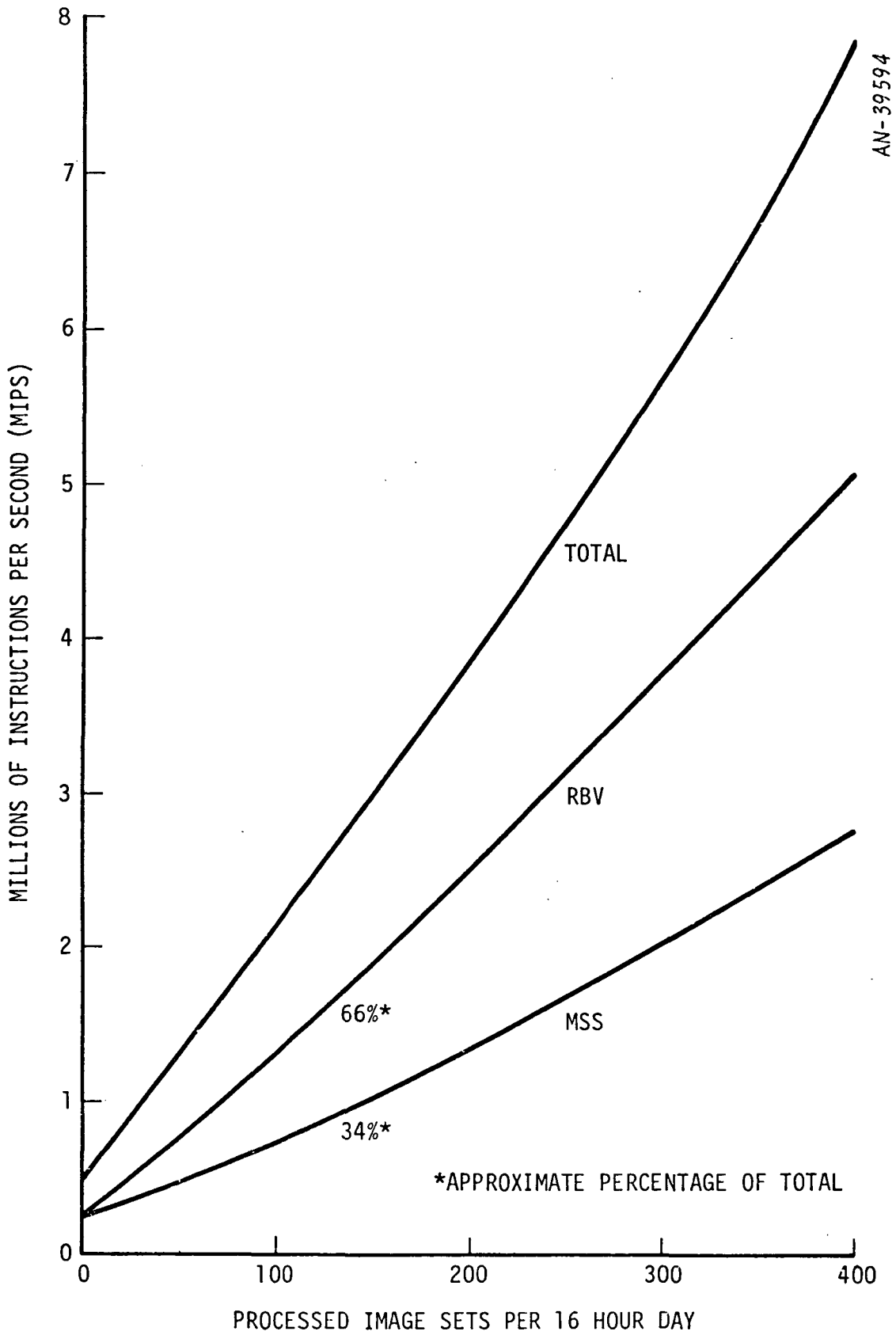

Figure 6. Mission 4, Low Processing Estimates

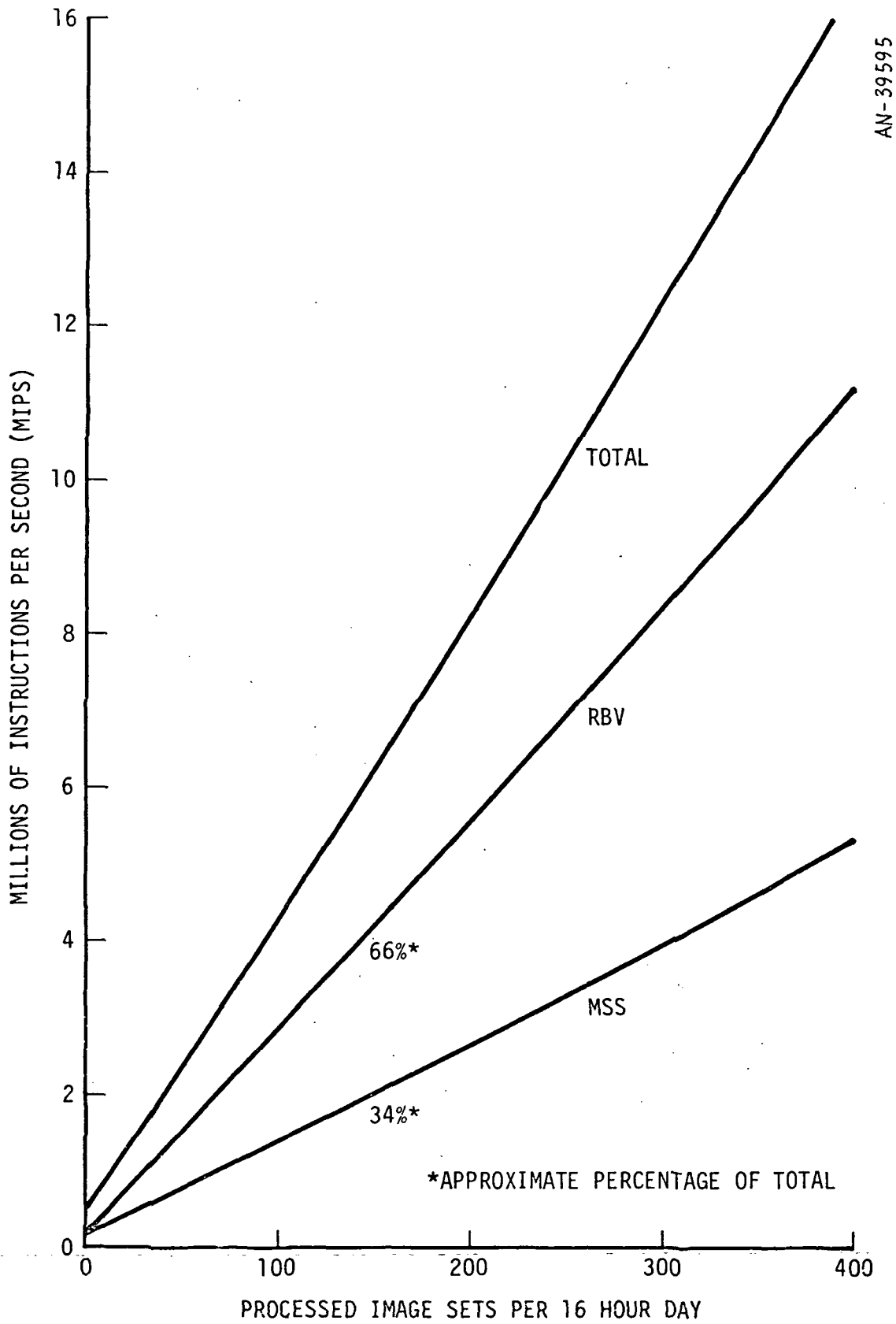

Figure 7. Mission 4, High Processing Estimates

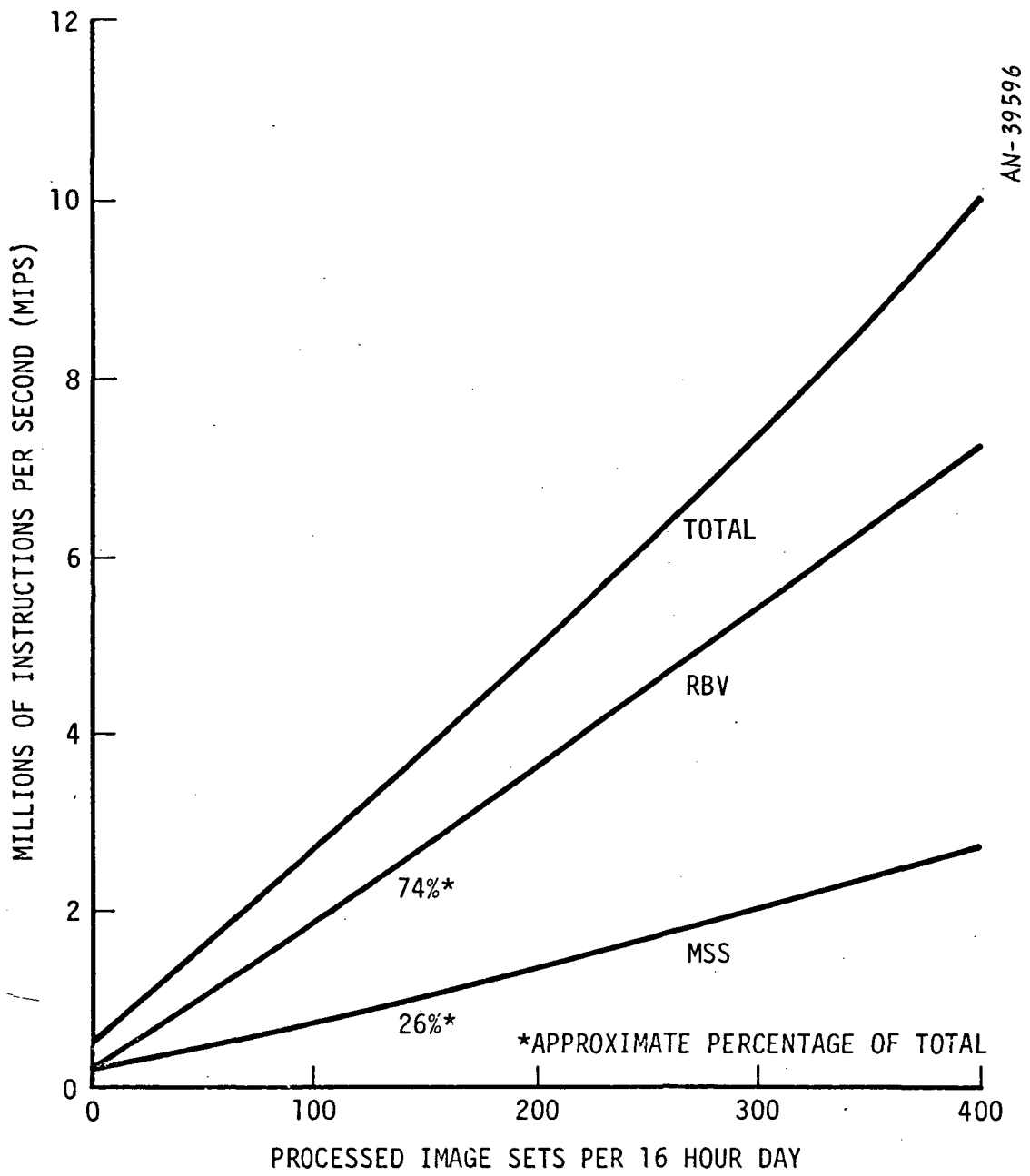

Figure 8. Mission 5, Low Processing Estimates

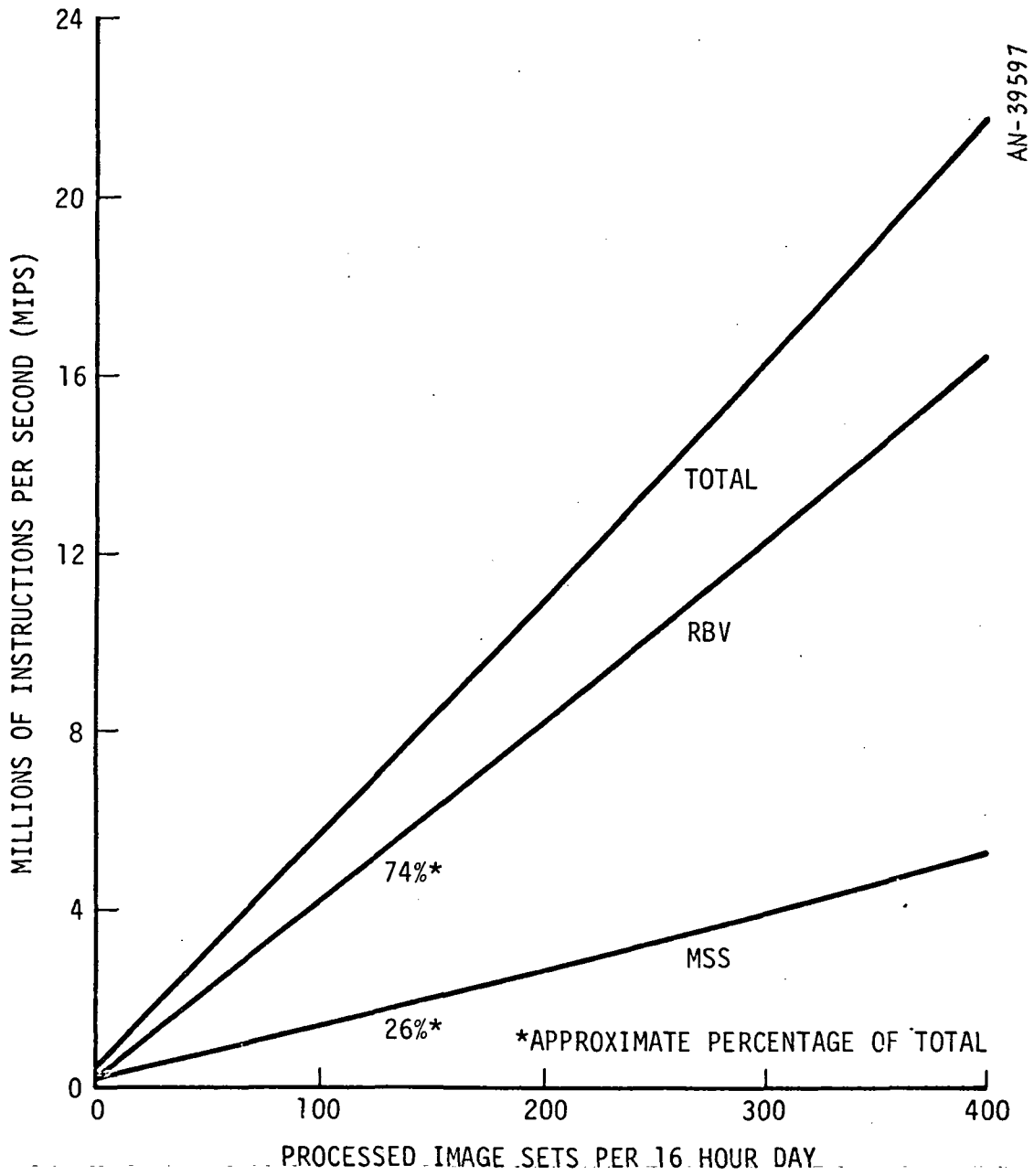

Figure 9. Mission 5, High Processing Estimates

TABLE 1
ESTIMATED DATA PROCESSING LOAD IN MIPS FOR 100 IMAGE SETS PER 16-HOUR DAY

FUNCTION	SYSTEM THREE						SYSTEM FOUR						SYSTEM FIVE																							
	Low			High			Low			High			Low			High																				
	RBV	MSS	%	RBV	MSS	%	RBV	MSS	%	RBV	MSS	%	RBV	MSS	%	RBV	MSS	%																		
BASE*	0.25	13.5	0.46	24.9	0.25	9.5	0.46	17.4	0.96	45.1	0.46	21.6	0.96	22.1	0.46	10.6	1.44	53.7	0.46	17.2	1.44	25.4	0.46	8.1												
RESEAU DETECTION**	0.01	0.5	0.00	0	0.08	3.0	0.00	0	0.02	0.9	0.00	0	0.32	7.4	0.00	0	0.03	1.1	0.00	0	0.48	8.5	0.00	0												
GROUND CONTROL POINT CORRELATION†	0.00	0	0.00	0	0.02	0.8	0.05	1.9	0.01	0.5	0.00	0	0.06	1.4	0.05	1.2	0.01	0.4	0.00	0	0.09	1.6	0.05	0.9												
BILINEAR INTERPOLATION	0.00	0	0.00	0	0.35	13.3	0.68	25.8	0.00	0	0.00	0	1.31	30.2	0.68	15.7	0.00	0	0.00	0	1.97	34.7	0.68	12.0												
NEAREST NEIGHBOR	0.03	1.6	0.06	32.4	0.00	0	0.00	0	0.12	5.6	0.06	2.8	0.00	0	0.00	0	0.18	6.7	0.06	2.2	0.00	0	0.00	0												
OVERHEAD	0.25	13.5	0.25	13.5	0.25	9.5	0.25	9.5	0.25	11.7	0.25	5.8	0.25	5.8	0.25	5.8	0.25	9.3	0.25	9.3	0.25	4.4	0.25	4.4												
SUBTOTALS	0.54	29.2	0.77	70.8	0.95	45.5	1.44	54.5	1.36	63.9	0.77	36.1	2.9	66.8	1.44	33.2	1.91	71.3	0.77	28.7	4.23	74.6	1.44	25.4												
SYSTEM TOTALS	1.31						2.39						2.13						4.34						2.68						5.67					

* Base includes: input (about 13% of base), radiometric correction (about 26% of base), mapping matrix coefficient, grid determination and annotation (about 2% of base), inverse output determination (about 13% of base) and output (about 45% of base).

** Reseau detection low estimate based on a field of 32² pixels (N_R = 32) and high on a field of 128² pixels (N_R = 128).

† GCP correlation low estimate based on a GCP/field ratio of 16/32, and high on a GCP/field ratio of 128/256 pixels.

TABLE 2
ESTIMATED DATA PROCESSING LOAD IN MIPS FOR 200 IMAGE SETS PER 16-HOUR DAY

FUNCTION	SYSTEM THREE						SYSTEM FOUR						SYSTEM FIVE																	
	Low			High			Low			High			Low			High														
	RBV	MSS	Σ	RBV	MSS	Σ	RBV	MSS	Σ	RBV	MSS	Σ	RBV	MSS	Σ	RBV	MSS	Σ												
BASE*	0.50	22.8	0.92	42	0.50	11.7	0.92	21.5	1.92	50	0.92	24	1.92	23.4	0.92	11.2	2.88	58.3	0.92	18.6	2.88	26.5	0.92	8.5						
RESEAU DETECTION**	0.01	0.5	0.00		0.16	3.7	0.00		0.04	1.1	0.00		0.63	7.7	0.00		0.06	1.2	0.00		0.95	8.7	0.00							
GROUND CONTROL POINT CORRELATION†	0.00		0.00		0.03	0.7	0.09	2.1	0.01	0.3	0.00		0.11	1.3	0.09	1.1	0.02	0.4	0.00		0.17	1.5	0.09	0.8						
BILINEAR INTERPOLATION	0.00		0.00		0.65	15.2	1.35	31.5	0.00		0.00		2.62	31.9	1.35	16.4	0.00		0.00		3.93	36.2	1.35	12.4						
NEAREST NEIGHBOR	0.06	2.8	0.12	5.5	0.00		0.00		0.24	6.3	0.12	3.1	0.00		0.00		0.36	7.3	0.12	2.4	0.00		0.00							
OVERHEAD	0.29	13.2	0.29	13.2	0.29	6.8	0.29	6.8	0.29	7.6	0.29	7.6	0.29	3.5	0.29	3.5	0.29	5.9	0.29	5.9	0.29	2.7	0.29	2.7						
SUBTOTALS	0.86	39.3	1.33	60.7	1.63	38.1	2.65	61.9	2.50	65.3	1.33	34.7	5.57	67.8	2.65	32.2	3.61	73.1	1.33	26.9	8.22	75.6	2.65	24.4						
SYSTEM TOTALS	2.19						4.28						3.83						4.94						10.87					

* Base includes: input (about 13% of base), radiometric correction (about 26% of base), mapping matrix coefficient, grid determination and annotation (about 2% of base), inverse output determination (about 13% of base) and output (about 43% of base).

** Reseau detection low estimate based on a field of 32² pixels (N_r = 32) and high on a field of 128² pixels (N_r = 128).

† GCP correlation low estimate based on a GCP/field ratio of 16/32, and high on a GCP/field ratio of 128/256 pixels.

TABLE 3
ESTIMATED DATA PROCESSING LOAD IN MIPS FOR 250 IMAGE SETS PER 16-HOUR DAY

FUNCTION	SYSTEM THREE						SYSTEM FOUR						SYSTEM FIVE																							
	Low			High			Low			High			Low			High																				
	RBV %	MSS %	Z	RBV %	MSS %	Z	RBV %	MSS %	Z	RBV %	MSS %	Z	RBV %	MSS %	Z	RBV %	MSS %	Z																		
BASE*	0.62	23.2	1.16	43.5	0.62	11.7	1.16	21.9	2.41	50.8	1.16	24.4	2.41	23.6	1.16	11.2	3.60	58.7	1.16	18.9	3.60	21.7	1.16	8.6												
RESEAU DETECTION**	0.01	0.3	0.00	0	0.20	3.8	0.00	0	0.05	1.1	0.00		0.79	7.7	0.00		0.08	1.3	0.00		1.18	8.7	0.00													
GROUND CONTROL POINT CORRELATION†	0.00	0	0.00	0	0.04	0.8	0.11	2.1	0.02	0.4	0.00		0.14	1.4	0.11	1.1	0.03	2.5	0.00		0.21	1.6	0.11	0.8												
BILINEAR INTERPOLATION	0.00	0	0.00	0	0.82	15.5	1.68	31.8	0.00	0.00			3.27	32.0	1.68	16.4	0.00	0.00			4.91	36.3	1.68	12.5												
NEAREST NEIGHBOR	0.07	2.6	0.15	5.6	0.00	0	0.00	0	0.30	6.3	0.15	3.2	0.00	0.00	0.00		0.45	7.3	0.15	2.5	0.00	0.00	0.00													
OVERHEAD	0.33	12.4	0.33	12.4	0.33	6.2	0.33	6.2	0.33	6.9	0.33	6.9	0.33	3.3	0.33	3.3	0.33	5.4	0.33	5.4	0.33	2.4	0.33	2.4												
SUBTOTALS	1.03	38.6	1.64	61.4	2.01	38.0	3.28	62.0	3.11	65.5	1.64	34.5	6.94	68.0	3.28	32.0	4.49	73.2	1.64	26.8	10.23	75.7	3.28	24.3												
SYSTEM TOTALS	2.67						5.29						4.75						10.22						6.13						13.51					

* Base includes: input (about 13% of base), radiometric correction (about 26% of base), mapping matrix coefficient, grid determination and annotation (about 2% of base), inverse output determination (about 13% of base) and output (about 45% of base).

** Reseau detection low estimate based on a field of 32² pixels (N_R = 32) and high on a field of 128² pixels (N_R = 128).

† GCP correlation low estimate based on a GCP/field ratio of 16/32, and high on a GCP/field ratio of 128/256 pixels.

TABLE 4
ESTIMATED DATA PROCESSING LOAD IN MIPS FOR 400 IMAGE SETS PER 16-HOUR DAY

FUNCTION	SYSTEM THREE						SYSTEM FOUR						SYSTEM FIVE																							
	Low			High			Low			High			Low			High																				
	RBV %	MSS %	Z	RBV %	MSS %	Z	RBV %	MSS %	Z	RBV %	MSS %	Z	RBV %	MSS %	Z	RBV %	MSS %	Z																		
BASE*	0.99	21.8	1.85	40.7	0.99	11.4	1.85	21.3	3.85	49.0	1.85	23.6	3.85	23.2	1.85	11.2	5.75	57.3	1.85	18.4	5.75	26.3	1.85	8.5												
RESEAU DETECTION**	0.02	0.4	0.00	0	0.32	3.7	0.00	0	0.08	1.0	0.00	0	1.26	7.6	0.00	0	0.13	1.3	0.00	0	1.89	8.6	0.00	0												
GROUND CONTROL POINT CORRELATION†	0.01	0.2	0.01	0.2	0.06	0.7	0.18	2.1	0.03	0.4	0.01	0.1	0.22	1.3	0.18	1.1	0.04	0.4	0.01	0.1	0.34	1.6	0.18	0.8												
BILINEAR INTERPOLATION	0.00	0	0.00	0	1.31	15.1	2.69	30.9	0.00	0	0.00	0	5.23	31.5	2.69	16.2	0.00	0	0.00	0	7.85	35.9	2.69	12.3												
NEAREST NEIGHBOR	0.12	2.6	0.25	5.5	0.00	0	0.00	0	0.48	6.1	0.25	3.2	0.00	0	0.00	0	0.71	7.1	0.25	2.5	0.00	0	0.00	0												
OVERHEAD	0.65	14.3	0.65	14.3	0.65	7.5	0.65	7.5	0.65	8.3	0.65	8.3	0.65	3.9	0.65	3.9	0.65	6.5	6.5	0.65	6.5	0.65	3.0	0.65	3.0											
SUBTOTALS	1.79	39.3	2.76	60.7	3.33	38.3	5.37	61.7	5.09	64.8	2.76	35.2	11.21	67.8	5.37	32.2	7.28	72.5	2.76	27.5	16.48	75.4	5.37	24.6												
SYSTEM TOTALS	4.55						8.7						7.85						16.58						10.04						21.85					

* Base includes: input (about 13% of base), radiometric correction (about 26% of base), mapping matrix coefficient, grid determination and annotation (about 2% of base), inverse output determination (about 13% of base) and output (about 45% of base).

** Reseau detection low estimate based on a field of 32² pixels (N_R = 32) and high on a field of 128² pixels (N_R = 128).

† GCP correlation low estimate based on a GCP/field ratio of 16/32, and high on a GCP/field ratio of 128/256 pixels.

The estimates for the design points for the three missions is given below.

	<u>MIPS</u>	
	<u>Low</u>	<u>High</u>
Mission 3 (200 scenes/day):	2.2	4.3
Mission 4 (200 scenes/day):	3.8	8.2
Mission 5 (250 scenes/day):	6.1	13.5

For comparison, the effects of using special-purpose computers as discussed in sec. 2.3 give the following requirements for the general-purpose processor part of the design.

	<u>MIPS</u>	
	<u>Low</u>	<u>High</u>
Mission 3:	2.0	2.4
Mission 4:	3.5	4.8
Mission 5:	5.5	6.3

These results are further discussed in sec. 2.4.

2.3 SYSTEMS INCORPORATING SPECIAL-PURPOSE HARDWARE

2.3.1 Introduction

Section 2.2 identifies the principal data processing features required for all-digital processing of NASA/ERS satellite data. Briefly, this data consists of 64-level gray-scale encoded picture elements (i.e., 6-bit pixels) from an MSS and from an RBV. The data is organized into rectangular arrays (frames) of (approximately) 2600×3000 pixels, and 4096×4096 pixels, respectively. A varying number of frames constitutes a scene. Although certain image processing system computations require significant amounts of computer execution time, processing of individual frames was estimated to consume the majority of the total execution time in all-digital operation.

This section addresses the following questions, all of which arise from the observation of computational imbalance identified above:

1. Can the use of special-purpose hardware permit relaxation of the potentially severe overall data processing requirements already identified?
2. What aspects of the "ERS data processing problem" are the most likely candidates for off-loading to such special-purpose hardware?
3. What kinds of hardware might be effected in this off-loading role?
4. What factors will contribute to system trade-off analyses between the use of special-purpose hardware versus the requirement of additional general-purpose hardware resource?
5. What range of improvement in overall system cost effectiveness can be expected with the use of such special-purpose hardware?

Preliminary answers to these questions are provided in the sections which follow; where time resources have not permitted detailed investigations of various points, the factors to be considered in more detailed investigations have been identified.

A The Nature of Off-Loading

To understand the factors which contribute to analyzing the effectiveness of off-loading of certain ERS data processing activities it is important to appreciate the precise kinds of configurations to be visualized. Figure 10a shows an ERS data processing installation organized around a single large-scale general-purpose computer; such a computer was assumed in the data processing studies reported in sec. 2.2. The computations performed within the general-purpose computer consisted of the following:

A. RBV Data

Reseau detection by shadow casting technique

*Variable number of ground control point correlations

B. MSS Data

*Variable number of ground control point correlations

C. RBV and MSS Data

*Radiometric corrections (by table lookup)

Computation of inverse transformation from output image
(corrected image) to input image

Generation of image gridding guide for application of inverse
transformation

*Video interpolation of output image pixel values

(The items marked with "*" are, as we shall see shortly, candidates for off-loading.) Each of these computations must be performed either for one frame of a scene or for all frames in a scene. The exact number of ground control point correlations is a system-definition parameter; this number can vary from an average of one per scene pair to as many as eight per scene.

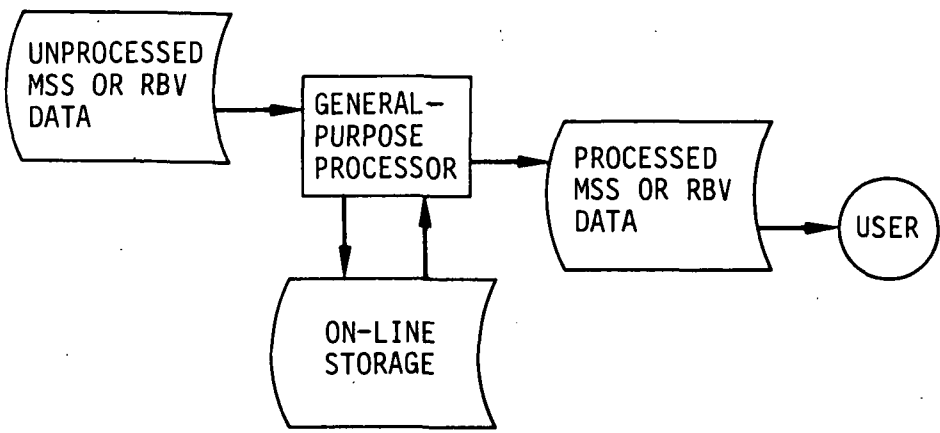

a) General-Purpose Processor Organization

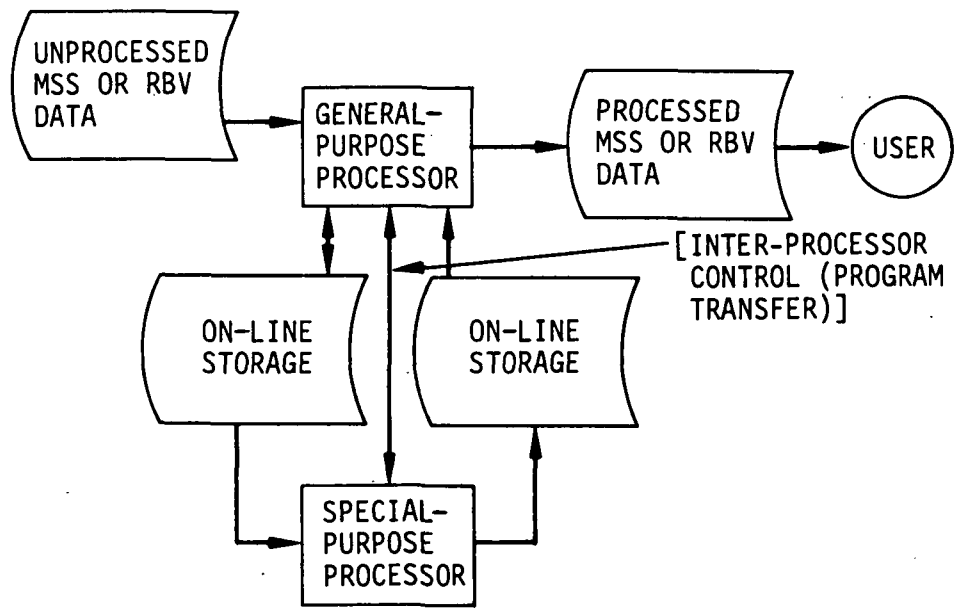

b) Special-Purpose Processor Organization

Figure 10. General-Purpose and Special-Purpose/Host Computer Organizations

Our estimates for the data processing load imposed by these functions are given in sec. 2.2. Off-loading any data processing function from the general-purpose processor to a special-purpose processor does not change the total amount of computation to be performed, it is important to note. However, certain advantages accrue if the exact nature of the function to be off-loaded permits its implementation in a significantly more efficient manner on the special-purpose hardware than on the general-purpose machine.

The general factors which suggest a function for off-loading are the following:

- Avaricious consumption of machine resources prior to off-loading
- Amenability to implementation by special-purpose computer equipment
- Ability to be operated independently of the remaining data processing functions

These, then, are the three "A's" of off-loading. In addition, of course, is the omnipresent requirement that off-loading represents substantial "cost" saving in terms of the overall system cost. This "cost" includes, but is not limited to, such factors as:

- The comparative reliability of the special-purpose hardware to that expected for the "host" computer system.
- The decreased flexibility which may be encountered as a result of "cast in wire" special-purpose system architecture.
- The increased system programming cost which may result from having to program two computer systems rather than one.
- The potentially increased overall processing time, on a per scene basis, which may be necessary for support of work queueing for the special-purpose gear.

- The possibility of increased storage requirements to contain these work queues.

Figure 10 indicates diagrammatically the role the special-purpose processing hardware can play in overall system organization.

Although there are no precise mathematical performance measurement criteria to support it, we believe that a performance ratio on the order of 10:1 is required to make use of an off-loading implementation sufficiently attractive over its general-purpose machine implementation. Thus, for example, off-loading would be indicated for any particular function only if the overall cost to perform that function on special-purpose gear is one-tenth that of the cost of general-purpose hardware.

B Off-Loading Analysis Basis

The data processor sizing estimates developed previously provide an indication of the all-digital system size for a range of implementation complexity and system loading. For purposes of simplicity, we assume here that off-loading is considered only for the nominal load points for the three systems.

Table 5 presents the salient features and data processing load ranges estimated for those system configurations apportioned as indicated between the various functions identified in the previous section.

C Identification of Off-Loadable Functions

The criteria suggested above can be applied to the system shown in table 5 as a means to identify those functions which are candidates for off-loading. The second factor applied in this selection is our understanding of the algorithmic nature of each task, interpreted in terms of the capabilities of potential special-purpose hardware (discussed in the next section). The candidate functions to be investigated in detail for their potential in off-loading are:

TABLE 5
SUMMARY OF SYSTEM CONFIGURATION REQUIREMENT

	Mission 3: 200 RBV and MSS Scenes/Day			Mission 4: 200 RBV and MSS Scenes/Day			Mission 5: 250 RBV and MSS Scenes/Day		
	Low	High	\bar{x}	Low	High	\bar{x}	Low	High	\bar{x}
Reseau Detection	0.01	0.16	0.5-3.7	0.04	0.63	1.1-7.7	0.08	1.18	1.3-8.7
GCP Correlation	0	0.12	0.0-2.8	0.01	0.20	0.3-2.4	0.03	0.32	0.5-2.4
Nearest Neighbor	0.18	---	8.3-46.7	0.36	---	9.4-48.3	0.6	---	9.8-48.8
Bilinear Interpolation	---	2.0	---	---	3.97	---	---	6.59	---
Other Functions	2.00	2.00	---	3.42	3.42	---	5.42	5.42	---
TOTALS	2.19	4.28	100%	3.83	8.22	100%	6.13	13.51	100%

1. The radiometric correction of input data to account for variations in sensor response
2. The computation of ground control points
3. The video interpolation of corrected output image pixels from the input image

These functions satisfy the selection criteria for the following reasons:

Radiometric Correction. As we have indicated before, these corrections can probably be performed with a simple table lookup procedure. Because the sensor response variations are only a slowly varying function of position within each frame, the values in the table must be changed only relatively infrequently compared with the number of pixels which must be processed.

Ground Control Point (GCP) Correlation. This computation compares a given picture region (ground truth) with the input image as a means to precisely identify the true location of the sensed image of a particular ground feature. Various algorithms exist to perform this computation; in addition, the possible necessity for interactive operation of the GCP operation further suggests its possible implementation off-line from the main general-purpose processor activity.

Video Interpolation. Since table 5 shows video interpolation requiring a high proportion of the processing load (i.e., up to ~49% for bilinear interpolation for Mission 5), this is the most likely candidate for off-loading. In addition, the specific algorithms which must be used (see below) are particularly amenable to special-purpose processor implementation since they possess these qualities:

- Regularity of applications. (They are applied repetitively to a large number of successive pixels.)
- Simplicity in required addressing patterns. (The algorithms can be organized to operate on input-image data in particularly convenient patterns as processing of an entire frame proceeds.)

Trial implementations of these algorithms on each of the special-purpose systems investigated will demonstrate the relative efficacies of these choices.

2.3.2 Candidate Special-Purpose Hardware

The special-purpose hardware configuration shown in fig. 10 suggests that candidate special-purpose hardware must meet a number of constraints, among them:

Capability for full self-operation without undue assistance provided by the host processor (which, presumably, is busy performing other activities).

The power to access data directly from either primary or secondary storage supplied by the general-purpose processing system. This is necessary in order to minimize the total data movement.

The capability to implement the candidate off-loadable functions.

Specific architectural alternatives are, therefore, limited to those special-purpose systems which comprise complete processors, and to those which have the necessary auxiliary functions to support the interactions necessary for the entire computation to "go through" with minimum delay and inter-processor interference.

A Architectural Alternatives

Two principal architectural alternatives exist which can meet these criteria, and at the same time, offer the potential for significant execution time saving by providing for especially efficient implementations. These alternatives are:

1. The use of dynamically microprogrammable off-line processors, accessing from the "host" computer primary or secondary (random access) memory system.

2. The use of hardwired processor techniques, in which algorithms are selected beforehand and which, because of the implementation, operate at circuit logic speeds.

B Advantages and Disadvantages

Certain general advantages and disadvantages exist for each of these alternatives, to wit:

(1) Advantages

A dynamically microprogrammable architecture has the advantage that algorithm selection can be semi-permanent. That is, after an efficient implementation is completed and checked out, and after operational experience has been gained with the algorithm and the processor executing it, it is possible to "back up" and make modifications.

The use of hardwired logic, however, offers some appreciable speed advantages. This situation occurs because of the nature of algorithmic processes; that is, a result of the lack of uncertainty in hardwired logic implementations. That same uncertainty (manifest in the form of conditional checking, and all the other trappings of software) works to "slow down" even the best microprogramming implementations.

(2) Disadvantages

Hardwired logic has an advantage in speed, but suffers severely in terms of overall flexibility. If the algorithms must be changed this can be accomplished only by complete rewiring of the special-purpose device(s).

The use of a dynamically microprogrammed processor has the disadvantage that a separate software system must be operated. The flexibility such a choice offers may not necessarily be offset by the increased system programming burden frequent (or even infrequent) changes in the software will evoke.

C Candidate Architectures

Three candidate architectures have been selected from those presently under development within the computing industry. The selection of these systems as candidates implies neither acceptance of their capabilities for the ERS data processing system, nor acquiescence to claims of superior design. Likewise, these architectures are not to be considered as "eliminated" from further consideration.

The three candidates are:

1. The Control Data Corporation Flexible Processor. This machine, which is currently under advanced development, features a relatively large control store and microprogram word length, particularly convenient input/output facilities, and relatively fast fixed-point-oriented internal processor computational resources. Internal processing is based on a 125-ns clock.
2. The Culler-Harrison, Inc., AP-120 Signal Processing System. This computer system was developed for a role in signal processing and is specifically oriented to spectral computations involving fast Fourier transforms (FFTs). Besides a novel arrangement for partially dynamic microprogram control, this machine has a highly flexible control/data store as well as read-only storage for constants and predefined functions. Internal processing is based on a 125-ns clock.
3. The General Dynamics High Speed Parallel Digital Processing Equipment. This equipment line is aimed at hardwired implementations of digital logic on fixed-point values for very high data rates. Use of ECL 10,000 logic permits processing speeds of up to 37×10^6 operands per second. Although the primary orientation of this processor system is toward FFT-related applications, the implementation is potentially capable of use in the aforementioned ERS computational roles.

2.3.3 Candidate Machine Architectural Details

This section presents some of the salient features of these three candidate special-purpose architectures. (The reader interested in the outcomes of the trade-off study may skip this section and continue reading at sec. 2.3.4.) Table 6 presents a summary of each architecture and an estimate of system cost.

A Control Data Corporation, Flexible Processor

The CDC Flexible Processor is a fully microprogrammed computer processor which has a highly flexible internal structure which permits its use in a wide variety of applications. Some of the specific characteristics of this computer processor follow.

(1) Microprogram Store

The microprogram store consists of 1024 words, 48 bits per word, 125-ns cycle time. This is referred to as the processor's "Large File." This memory is implemented with Shottkey TTL bipolar active element memory, with 256 bits/integrated circuit. Control of the "Large File" is by means of two generalized I/O busses, which can operate in parallel at a rate of one 16-bit word per 125-ns period; the 10-bit address to a word within the Large File is carried on one of these busses.

(2) Register Files

Four other register files are available as a resource to the executing microprogram:

1. The "Scratchpad File," consisting of up to 2048 words of up to 32 bits/word. This memory is also read/write, random addressible, bipolar TTL logic with a cycle time of 125 ns.
2. The "Small File," consisting of 16 words, 32 bits/word, 125-ns cycle time for simultaneous read and write.
3. The "Input File," consisting of 16 words, 32 bits/word, 125-ns cycle time. This file has a 4-bit counter associated with it which can be used as a circular pointer within the input file.

TABLE 6
SUMMARY OF CHARACTERISTICS OF SPECIAL-PURPOSE HARDWARE

MACHINE	(1) CDC FLEXIBLE	(2) CHI AP-120 SIGNAL	(3) GENERAL DYNAMICS
	PROCESSOR	PROCESSOR	HIGH-SPEED DPE
Architectural Type	Microprogrammable	Microprogrammable	Pipeline Processor
Basic Cycle Time	125 ns	125 ns	27 ns (ECL 10,000 Logic)
Memory System			--
Control Store	1024 x 48 bits @ 125 ns	1024 x 32 bits @ 125 ns	--
Register Store	=8000 x 8 bits capacity	=6000 x 32 bits capacity	--
Word Width	16 bits	16/32 bits	16 bits
Processor Speeds			
Fixed Add	125 ns	125 ns	27 ns
Fixed Multiply	250 ns	350 ns	27 ns*
Floating Add	software	500 ns	?
Floating Multiply	implement	625 ns	?
Input/Output			Buffer unit available
	(a) circular buffer of 16 x 32 bits @ 125 ns	Two 32 bits @ 125 ns busses	
	(b) 32 bits direct output		
	(c) 4 I/O ports		
Cost ("typical system")	\$30K**	\$60K	Not available†
Availability			
First Prototype Installed	1972	3rd quarter, 1973	1972
Delivery	Negotiable; =12 mo	4-6 mo	18-24 mo†

* Assumes saturated pipeline.

** Full configuration, in large quantities.

† Highly dependent on configuration.

4. The "Output File," consisting of 1 word, 32 bits/word, 125-ns cycle time. This "file" can be used for output of results simultaneously with computations and with input. For each of these files, both address and control information (whichever is appropriate) is transferred by means of the two data busses.

(3) Processor Facilities

Some of the specific features of the processor are the following:

1. 8-bit by 8-bit multiply, implemented on one printed circuit card with hardwired static logic, operating in a total period of 250 ns.
2. 16-bit by 16-bit adder, expandable to a 32-bit by 32-bit adder, which operates in a total cycle time of 125 ns.
3. 16 levels of interrupt, including appropriate masking capabilities
4. 5 condition registers, each 16 bits in length and parallel masking registers of the same length. These registers are used to store the outcomes of previously completed operations, and, under mask control, can be used to alter the flow of microprogram control.
5. A 16 word, 10 bits/word, instruction pushdown stack. This stack can be used to implement very fast subroutine calling within the microprogram, or can be used to support recursive invocations of microprogram subroutines.
6. A flexible shift matrix, including 1- to 8-bit and full-byte shifts and exchanges of operands. This shift matrix width is the same as the width of the adder selected for the processor. (See item 2 above.)

7. Four independent "input/output" ports which operate in a manner similar to that for a channel. These ports can be connected to other flexible processors or to a large memory external to the microprocessor (e.g., the implemented processor's main memory).
8. The processor requires approximately 10 vertical inches in a standard 19-in rack mounting system. Each four-layer printed circuit board measures 7.5 by 10.0 in.

B Culler-Harrison AP-120 Signal Processor System

The Culler-Harrison, Inc., AP-120 Signal Processor System is a fully microprogrammable processor with unique features and capabilities, particularly in regard to internal processing speeds for floating-point arithmetic. Some of the features of this system follow.

(1) Microprogram Memory

The basic microprogram memory (writable control storage) consists of 1024 words, 32 bits/word, 125-ns cycle time; 512 words of this memory is hardwired, and the remaining 512 words are dynamically changeable (see below). The microprogram control is of the "horizontal" type.

(2) Registers

Various kinds of machine-accessible registers are provided, as follows:

1. There are 16 index registers, 16 bits/word. These registers are used to store microprogram base and relocation constants as well as microprogram index values.
2. There are 16 "Scratch Pad" general registers, 32 bits/register. These registers are used to contain intermediate floating point or fixed point computation values.
3. There are 4096 words, 32 bits/word of MOS (metal oxide semiconductor) random access memory. This space is used as a

dynamic swap area for segments of microcode used in the main microprogram memory and, in addition, can be used for data storage.

4. There are 2048 words of 32-bit read-only memory which are used to store various constants specific to the processor application. For example, the constants used in the fast implementation (by table lookup and interpolation) of standard functions (sin, cos, etc.) are stored in this region.

(3) Processor Facilities

The microprogrammable processor provides for both fixed-point and floating-point format arithmetic. The floating-point format employs a 24-bit fraction and an 8-bit exponent. The properties of the various functional units follow.

Fixed Multiply. A 16-bit by 16-bit fixed multiply can be completed in three internal clock periods, or 375 ns. A 32-bit result is produced.

Floating Multiply. A fully general 32-bit by 32-bit floating-point multiply operation can be completed in 5 internal clock periods, or 625 ns. This time includes the time for operand renormalization.

Fixed Add. A 16-bit by 16-bit fixed add operation can be completed in two internal clock periods.

Floating Add. A general 32-bit by 32-bit floating point add operation is completed in a total of 4 clock periods, or 500 ns.

Shift Matrix. The shift matrix can operate on 16-bit quantities, and complete shifts of from 1 bit to 16 bits in one clock period each.

For all of these functional units it is important to appreciate that the overall execution time quoted is for the delay before which another operation of the same kind can be begun. Thus, overlap of all of these units is possible and highly parallel operation can result.

(4) I/O Facilities

Input/output between the microprogrammable processor and its "host" machine is performed on one of the data buss systems: the I/O buss or the "host" buss. Each buss is 32 bits wide and can process a complete 32-bit operand once each 125 ns. Associated with the buss capabilities is a 32-bit accumulator which is also addressable from within the micro-programmed processor.

C General Dynamics High-Speed Digital Processing Equipment

The General Dynamics High-Speed Digital Processing equipment consists of a specially tailored pipeline processor, each pipeline stage of which can perform certain elementary operations on operands passed to it from its predecessor. In turn, each pipeline stage can deliver operands to the successor pipeline stage. The initial and terminal pipeline stages are used to accept input operands and disgorge output operands; input and output operand streams are assumed to originate from a "host" processor which has appropriate input/output data rates.

General Dynamics' current implementation technology permits each pipeline stage to be as short as 27 ns, for an overall computation rate of 37×10^6 operations per second. For these operational speeds ECL 10,000 logic is required; slower speed Shottky TTL type logic permits stage times on the order of 50 ns.

Each special-purpose pipeline processor must be specifically designed for its ultimate operational function. Individual stages are constructed with standard subcomponents, and individually programmed; the program is expressed as a collection of wiring performed by automatic wire-wrap equipment. A single processing stage (i.e., a single pipeline stage) can consist of one or more "boards," the number of boards depending on the complexity of the particular processing function.

(1) Standard Pipeline Components

The General Dynamics' development group has completed design of certain relatively standard functional stages, among them:

Adder Stage. The adder stage accepts two 16-bit fixed point operands in bit-parallel at each 27-ns (ECL 10,000 logic) interval; the 17-bit sum is delivered to the output register after a stage delay of 27 ns.

Multiplier Stage. The multiplier stage accepts two 16-bit fixed point operands each 27 ns system period. The total delay through the multiplier stage is 10 system periods, or 270 ns in the case of ECL 10,000 logic.

Divider Stage. The divider stage accepts two 16-bit fixed-point operands once each 27 ns (ECL 10,000 implementation); the total delay for this stage is on the order of 350 ns. No exception processing (such as for a zero divisor) is performed in current implementations although GD has indicated that such exception processing could be performed.

(2) Pipeline Organization

There is no limit to the length of the processing chain, since each stage's operation is synchronized to arrival of data on its input registers. The overall pipeline throughput is a function of the smallest of the individual pipeline stages' operand acceptance rates. Thus, for example, a pipeline constructed of adders, multipliers, and dividers such as those described above can operate on a new operand pair at the 37-MHz rate indicated previously.

(3) Special-Purpose Pipeline Stages

For the NASA/ERS application special-purpose pipeline stages would have to be designed, checked out, and physically implemented. At the present time (and with present information on the GD system) it is not possible to specify the exact nature of such designs.

2.3.4 Implementation Estimates

In this section we provide preliminary characterizations of the manner in which each of the three special-purpose processors just described might be used in an off-loading role for NASA/ERS all-digital image processing. In each case we make certain operational assumptions which allow concentration on the primary issue--estimation of overall processing time saved; subsequent studies should address the validity of these assumptions in substantially greater detail.

(1) We assume that the special-purpose processor is supported by the "host" machine, a general-purpose processor, via its existing input/output structures. For example, this may occur via a "selector" channel or channels in such a way that data is streamed to and from the off-line processor at very high rates.

(2) We assume that the "host" machine processor participation in the control activities necessary to support the off-line operation requires at most 10% of the originally estimated processing load. Very likely, the actual figure would be considerably below this, particularly if optimum use is made of concurrent operation of host machine channels and processor. The figure of 10% is in keeping with our earlier mentioned threshold for efficacy of off-loading.

(3) We assume that the host machine has sufficient primary and secondary memory resources to support enqueueing of relatively large amounts of "to be completed" all-digital image processing. This assumption is necessary because the efficiency attained by the special-purpose gear is highly dependent on the availability of data on a nearly continuous basis; in other words, we are assuming that it is possible to "keep the special-purpose hardware busy" a substantial portion of the available processing time.

A Radiometric Correction

As mentioned earlier, the radiometric correction task can be assumed to operate by table lookup since the correction table changes only slowly as a function of the position within the frame being processed. Implemented on a special-purpose processor, this function requires two major steps:

1. Periodic update of the "translation table" which specifies the radiometric corrections
2. Streaming of the pixels to which the particular translation is to be applied through the special purpose processor.

Because of the relatively slow rate of table update, this function can be assumed to be performed within the usual 10% "overhead" allowance. We can now estimate the processing time for data streaming operation on each of the candidate special-purpose architectures.

CDC Flexible Processor. Input and output of pixels can proceed at machine cycle rates--on the order of 8×10^6 pixels/s. Application of the (current) radiometric translation requires use of the pixel value as an index into the translation table, and placement of the indexed value on the output register; this operation can be performed in one machine cycle of 125 ns. Because input/output and internal processing can be performed concurrently, each pixel is processed at the rate of 8×10^6 pixels/s.

CHI, AP-120 Signal Processor. This processor has two input/output busses which can operate concurrently with the microprogrammable processor. Hence, the computation can be organized in a manner similar to that for the CDC Flexible Processor, and can achieve the same rate: radiometric correction at 8×10^6 pixels/s.

GD High-Speed Digital Processing Equipment. In this special-purpose architecture it is possible to construct a special purpose pipeline "stage"

which stores the current value of the translation table in a 64×6 bit array; loading of this array to maintain currency of the translation table can be accomplished in a manner similar to that used to load constants into circular memories in the GD FFT implementations. If ECL 10,000 logic is employed, each pixel can be translated at a rate of 27 ns per pixel, or for a total rate of 37×10^6 pixels/s.

B Ground Control Point Correlation

The ground control point (GCP) correlation computation can be characterized as consisting of an iterative series of sub-frame difference computations. A variety of techniques can be applied to the control of the selection of the "next point" within the search region, given the outcome of the correlation computation performed for the "previous point." The sub-optimal estimation algorithm used in sec. 2.2 is descriptive of the number of iterations likely to be required.

Implementation of the GCP correlation computation on special-purpose gear can take advantage of the fact that each iterative step involves essentially the same computations to be performed--only the reference point (which governs the pixel addressing) varies. One can suppose that there are two streams of data: (1) the reference point based region within the search region, and (2) the ground truth information. The special-purpose processor must compute the sum of the differences between each pixel pair.

CDC Flexible Processor. The circular input file within the CDC Flexible Processor can be used to accept data at a total rate of 250 ns per pixel pair (two streams). The single subtraction (the difference between the pixel pair values) and the accumulation of the sum of the magnitude of the differences can be accomplished with three microinstruction executions. This sets the rate to one computation per 3×125 ns or 375 ns. Accumulation of the output is included in this processing time allowance (there are sufficient registers to contain this value). The stream rate is, therefore, 2.67×10^6 pixels/s.

CHI AP-120 Signal Processor. This processor can also support two input pixel streams, at a rate of 250 ns/pixel pair. As with the CDC machine, the absolute difference and summation operations can be accomplished with three instructions per pixel pair; however, these can be overlapped at a rate of one initiation of the fixed add unit per machine cycle. The resulting computation is input/output limited (in the large), at a rate of 250 ns/pixel pair. The stream rate is, therefore, 4×10^6 pixel/s.

GD High-Speed Digital Processing Equipment. For use of this special processor option in the GCP correlation computation, a two-stage pipeline could be employed. The first stage would form the absolute difference between the two input pixels, and the second stage would accumulate the sum of the differences (the absolute correlation). Each stage could operate (with ECL 10,000 logic) at a rate of the new operand each 27 ns; the total throughput rate would therefore be 37×10^6 pixel pairs/s.

C Video Interpolation

There are two primary means for performing the video interpolation: (1) the use of the "nearest neighbor" approximation, and (2) the use of bilinear interpolation. It is indicated in sec. 2.2 that the latter was on the order of six times more resource consumptive than the former and, as result, it was suggested that algorithms for performing this computation should be the subject of substantial further investigation. In either case, it can be assumed that the frame to which the correction transformation is to be performed is "gridded" into small regions within which no output pixel is shifted more than one inter-pixel spacing interval. The identification of these grid regions is clearly performed best in the general-purpose host computer. We treat the two primary algorithms for video interpolation separately.

(1) Nearest Neighbor Algorithm

This algorithm requires the identification of which pixel in a four-pixel grid is nearest to an interpolant point located within the four-pixel

region. In effect, there are six data streams, as follows:

(1-4) The values of pixels at the four corners of the interpolation region

(5-6) The two coordinates of the interpolation point

It can be assumed that the coordinate pairs of the interpolant point are given in floating point format; in this case, the nearest neighbor computation can be considered as performed in the following fashion:

Step 1: Add $0.5 \times$ (distance between pixels) to each coordinate

Step 2: Convert each value to an integer

Step 3: Use resulting pair as selection address for nearest neighbor. The possible pairs are (0, 0), (0, 1), (1, 0), and (1, 1).

Step 4: Transmit selected output pixel

CDC Flexible Processor. Good use of the facilities provided by this machine suggest the following limiting factors: (1) the maximum input/output rate is on the order of one pixel selection each 750 ns, and (2) the processing time for each pixel is on the order of less than 750 ns per pixel selection. Thus, for this special purpose processor the computation appears to be I/O limited at a rate of 1.34×10^6 pixels/s.

CHI AP-120 Signal Processor. This special-purpose processor has slightly less I/O capability than the CDC machine, and the slightly greater processing power does not compensate. It is estimated that the CHI AP-120 Signal Processor can perform the nearest neighbor computation at a rate of 1.0×10^6 pixels/s.

GD High-Speed Digital Processing Equipment. The GD concept would, in this instance, require a multi-stage pipeline in which each set of operands is treated partially in a serial fashion (because of the two-operand input buffer limitation). None of the computations required,

however, would need more than (the ECL 10,000 implementation rate of) 27 ns/pixel. Thus, the overall processing rate would be 37×10^6 pixels/s.

(2) Bilinear Interpolation

The bilinear interpolation algorithm, under the stream assumptions given above for the simpler nearest neighbor interpolation method, requires the following operations for each pixel: 6 addition/subtraction operations, and 3 multiplication operations. The implementation limitations for the three candidate architectures are as follows:

CDC Flexible Processor. The computation is processing (rather than input/output) limited. The instruction execution complement given above requires 1.25- μ s per interpolation. The overall rate is, therefore, 0.8×10^6 pixels/s.

CHI, AP-120 Signal Processor. As before, the computation is processing limited. However, because certain of the computations can be overlapped in the AP-120 Signal Processor, it is estimated that the overall computation can be performed in a total of 1.125 μ s. The overall rate, then, is 0.875×10^6 pixels/s.

GD High-Speed Digital Processing Equipment. For this implementation a multi-stage pipeline would be required. Assuming that a hardwired processor sequence can be constructed to implement the bilinear interpolation, it is estimated that the computation could proceed at half the equipment's maximum rate, i.e., at approximately 18.5×10^6 pixel interpolations per second.

D Additional Comments

The relatively high data rates obtained in the foregoing analyses suggest that, for certain of these implementation options to be truly effective, particular care would have to be exercised in the design of

the host processor input/output control mechanisms. For example, packing of words would probably be indicated in all instances in the General Dynamics system.

Table 7 summarizes the processing rates derived for each of the three candidate systems and for each of the candidate off-loadable functions discussed.

2.3.5 Off-Loading Trade-Off and Results

The effect of off-loading the particular computational activities described above can be computed by replacing each off-loaded function with 10% of its pre-off-loading resource requirements (this 10% is required to support control of the special purpose hardware), and re-totaling the resulting general-purpose requirements. The results of this computation are shown in table 8, where, for convenience, we have repeated the resource estimates of sec. 2.2 for the general-purpose architecture.

These figures show that the following estimated savings through the use of special-purpose hardware can be achieved for the three configurations (at their nominal design loads):

System 3: 7.3-44.6%; 0.16-1.91 MIPS

System 4: 8.6-42.0%; 0.33-3.45 MIPS

System 5: 9.3-53.5%; 0.57-7.22 MIPS

It is important to emphasize that the savings may be more substantial if any of the systems is operated at rates greater than the design load since at such rates the relative proportions of resource use change markedly.

2.4 MISSION CONFIGURATIONS 3, 4 AND 5: ALL-DIGITAL DESIGN APPROACHES

This section addresses all-digital design approaches for mission configurations 3, 4, and 5. The three configurations differ only in terms of the applied data input rate and the mix between RBV and MSS data. The principal parameters describing these three systems are as follows:

TABLE 7
 SUMMARY OF ESTIMATE EXECUTION RATES
 FOR OFF-LOADED ERS FUNCTIONS
 (pixels/second)

	<u>Function</u>	<u>CDC Flexible Processor</u>	<u>CHI, AP-120 Signal Processor</u>	<u>General Dynamics High-Speed DPE</u>
(1)	Radiometric Correction	$8. \times 10^6$	$8. \times 10^6$	$37. \times 10^6$
(2)	GCP Correlation	2.67×10^6	$4. \times 10^6$	$37. \times 10^6$
(3)	Video Interpolation:			
3a	Nearest Neighbor Interpolation	1.34×10^6	1.0×10^6	$37. \times 10^6$
3b	Bilinear Interpolation	0.8×10^6	0.875×10^6	18.5×10^6

TABLE 8
 REDUCTION OF REQUIRED MIPS DUE TO FUNCTIONAL OFF-LOADING

<u>System/Rate</u>	<u>MIPS Required Without Special Processing</u>	<u>MIPS Required With Special Processing</u>
System 3/200 Scenes/Day	2.19-4.28	2.03-2.37
System 4/200 Scenes/Day	3.83-8.22	3.50-4.77
System 5/250 Scenes/Day	6.13-13.51	5.56-6.29

1. Input
 - System 3
 1. 200 scenes/day
 2. One 5-channel MSS
 3. One panchromatic RBV
 - System 4
 1. 200 scenes/day
 2. One 5-channel MSS
 3. Two 50 × 50 nmi RBVs
 - System 5
 1. 250 scenes/day
 2. One 5-channel MSS
 3. Two 50 × 50 nmi RBVs
 4. Two 100 × 100 nmi RBVs
2. Output (All Systems)
 1. 1:10⁶ scale film imagery
 2. Imagery on computer tapes
3. Throughput

All U.S. data (25 scenes/day) processed within 24 h of receipt of interface data
4. Operation
 1. 16 h operation/day
 2. All-digital processing

The system, as we conceive it, should encounter no difficulty in processing the U.S. data (item 3) within the required deadline. At the very worst, meeting this requirement may involve additional machine availability assurances and possibly, selective organization of the systems' input queue.

System sizing has been performed to achieve an average throughput rate, as indicated above, using a 16-h, 7-day week. Sufficient input and output device availability has been assumed in order that the efficiency of the human operators is not a factor in the system sizing. However, it would be advisable to operate the all-digital systems on a full 24-h/day, 7-day basis as a preventive measure to protect against problems in daily system hardware cold starts, or for other unscheduled maintenance. The staffing for the computer system operation has, therefore, been assumed to require a full four shifts/week. System hours not otherwise utilized for actual processing can be allocated to system software development, scheduled maintenance, and for all-digital processing which does not require full staffing for certain of the peripherals (e.g., the film recorders generally require a human attendant).

2.4.1 System Configuration

The system configurations studied involve the use (1) of a large-scale, general-purpose digital computer system, and (2) the combination of a large- or medium-scale general-purpose machine with special-purpose hardware. In both cases, the systems possess a collection of input and output units, and, the central processor. The second option has, in addition, general-purpose, special-purpose machine intercommunications facilities. The overall configurations are shown in figs. 10a and 10b.

2.4.2 Input Units

The input units consist of two video tape recorder/reproducers (VTRs) which are interfaced through appropriate input/output equipment to the general-purpose processing units. The RCA TR-70 is the assumed device for VTR; this recorder/reproducer has the capability of handling both the RBV and the MSS data. Reproduction can be performed at either one-half or one-quarter of the VTR recording rate.

The input/output capability of the general-purpose computer is assumed to be in the 10^6 byte/s range. The trade-offs which suggest this compromise value are the balance between speed and cost; "reasonably priced" large capacity disk units are assumed.

MSS data is recorded at a rate slightly faster than 16×10^6 bits/s, of which an average of at most 8×10^6 bits/s is actually useful information storage on the VTR. Thus, by discarding this utilization factor (i.e., 50%), by compressing bits into bytes (a 6:1 factor), and by reproducing the data at the one-half rate, one achieves an effective rate of 0.67×10^6 bytes/s across the VTR-to-computer interface.

RBV data must be digitized at, or above, the Nyquist frequency; signal-to-noise ratio consideration restricts the useful information to 6 bits per pixel. Because one frame of RBV data is recorded in a total of 3.3 s, and because an RBV frame consists of 4096×4096 pixels, an equivalent data rate of 5.08×10^6 bytes/s can be assumed. Reproduction at the one-quarter rate mentioned above will still be insufficient to "match" data rates; there are three options available to circumvent this problem:

1. Re-record the data by reproducing the data at the one-quarter rate and copying it on a second machine at full rate. This second machine can then reproduce the data at the one-half rate and provide the data to the interface at processible speeds.
2. Pack data 8 bits per byte and repack from 8 to 6 bits per byte utilizing software within the general-purpose machine. This would result in a data rate of 0.93×10^6 bytes/s at the computer interface, but would require an additional "pass" on the data once in machine processible format.
3. Provide a custom buffering unit between the VTR and the computer, such that the data is clocked out to the computer at an acceptable rate. The duty cycles for the RBV system for

the mission configurations under consideration (including 200-ms interface time) are:

MC3: 3.5 s of data/25 s - 0.14 duty cycle

MC4: 14 s of data/25 s - 0.56 duty cycle

MC5: 21 s of data/25 s - 0.84 duty cycle

These duty cycles define the required average output rate for each configuration. Taking advantage of the duty cycles, combined with use of the playback rate reduction technique, one achieves an acceptable data transfer rate in all but Mission Configuration 5. In this case, a rate of 1.06×10^6 bytes/s results, marginally unacceptable.

It is evident that additional studies will be required to select an appropriate solution to this problem. Additional costs not considered in the remainder of this study may be incurred, depending on the particular solution chosen. For example, the first technique will require additional VTRs, both to meet the increased processing demand and to assure adequate overall reliability; the second approach will require additional computer resources in case a surplus is not available; and, finally, the third approach will require a specially built storage buffer.

2.4.3 Output Units

The output units recommended consist of high-density digital tape units (HDDTs), interfaced to a high-rate input/output port on the general purpose computer system, and, in turn, laser beam recorders (LBRs) connected to the bank of HDDTs. The normal data flow is from the digital processing unit to the HDDT, and then from the HDDT to film using the LBRs. Direct output from the digital computer system to the LBR is an option which has some utility; this point should be addressed in more detail when specific system designs are studied.

Two LBRs are envisioned for either of the two basic system configurations (general-purpose or general-purpose/special-purpose). Two, three,

and four HDDT units are recommended in support of the data processing needs for Mission Configurations 3, 4, and 5, respectively. These HDDT units should have record/reproduce ratios of 1.0, 2.0, and, possibly 4.0. With this speed change capability, the data flow rates allow recording corrected digital imagery on a high-density tape at the nominal 10^6 byte/s rate and, in addition, reproduction of the data from HDDT onto film at 2.0×10^6 , or possibly, 4.0×10^6 bytes/s, depending on the LBR design and HDDT capability. Using the higher figure, eight output frames (four on each of 2 LBRs) can be produced for each frame processed through the all-digital data processing system.

The second LBR and the multiple tape units are necessary for reliability, as well as operational, considerations.

This system organization permits the operators to produce more than one copy of "first generation" film for users, provides for production of custom gamma products, and provides the capability to produce digitally enlarged frames and high-density digital tape products. These activities require only a moderate amount of translation and control activities at the HDDT/LBR interface. Production of 9.5-in film containing four separate registered frames is also feasible; this product could be used in additive viewers provided that acceptable film dimension stability permits achieving the necessary registration.

HDDT files will be maintained as the corrected data archive. Additional HDDT units (of a somewhat different technical capability) may be necessary for production of a HDDT product if the HDDT units selected for the output unit are incompatible with existing user computer systems. For example, the IVC units described in sec. 4 are inexpensive, are presently operational, and are adaptable to a variety of computer system interface requirements. These units do not, however, have multiple speed capability, although they do have a search capability. This deficiency can be overcome to a limited extent by production of a HDDT wherein each

transverse track has an integral number of lines of data for one spectral band, and where sequential transverse tracks carry data from the spectral bands in cyclic order. Thus, a user equipped with a computer system capable of accepting data at one-half the recording rate (i.e., at about 0.5×10^6 bytes/s) can accept alternate tracks, and transfer two spectral bands at a time. The remaining data is collected in a subsequent pass over the file.

It does not appear that this "selective track" capability would be available for use in recording data, and this implies that the primary HDDT device for use in the all-digital image processing system may be restricted to a device such as the RCA TR-70. This unit would permit the appropriate redundancy with identical input units, in addition.

2.4.4 Digital Processing Units

This section addresses the available options for the major component of the all-digital image processing system: the central digital computer system(s). Section 2.2 relates our investigation into the size of computing resource required; sec. 2.3 analyzes the relative utility of off-loading of certain of the image processing functions onto special-purpose computer systems operating under the direction and guidance of the host machine. In both architectural alternatives, there is a substantial need for computing resource which can be satisfied only by the existence of a general-purpose computer.

The estimated machine resources, in terms of MIPS for the three mission configurations at their respective design points are as follows:

System 3(GP): 2.2-4.3 MIPS

System 4(GP): 3.8-8.2 MIPS

System 5(GP): 6.1-13.5 MIPS

If special-purpose hardware is employed as a means of off-loading certain of the image processing work, then the demands placed on the general-purpose machine decrease somewhat. In the presence of such off-loading, the following machine resource requirements result:

System 3(GP/SP): 2.0-2.4 MIPS

System 4(GP/SP): 3.5-4.8 MIPS

System 5(GP/SP): 5.5-6.3 MIPS

The effect of off-loading is, therefore, seen to be substantial but not overwhelming.

There still remains the problem of selecting the appropriate general-purpose computer system to support the mission. In general, the analysis of a system for the purposes of providing a good basis for the selection of a basic general-purpose computer system entails an investigation of much greater detail than that completed here. This is true for many factors, not the least of which among them is the uncertainty associated with "rating" a computer system's performance. The problem is compounded by the fact that a certain portion of the machine resource is necessarily lost in support of management of the system's storage facilities; this factor has not been addressed directly in the present study. It is evident that substantial further investigation will be necessary before a final machine selection can be made; such a study would address specific configuration questions pertaining to memory and peripheral organization, as well as the central issue of basic machine processor performance.

It is possible, however, to provide a preliminary indication of the range of computer systems which, within the limitations of information known at the present, appear to be suited to this application. These particular machines are mentioned because of the clearly indicated need for substantial machine computing resource, as well as the corresponding need for substantial amounts of memory and peripheral storage capability.

Typical machines which have the capability to operate in the 2.0 to 13.5 MIPS range suggested by the foregoing estimates are:

- IBM 360/195, which has a capability on the order of 12-14 MIPS
- CDC 7600, which has a capability in the range of 10-15 MIPS
- IBM 370/168, which, with appropriate complements of memory, can operate in the range of 5-10 MIPS
- IBM 370/158, which can operate in the 3-8 MIPS range
- CDC 6600, which is capable of operation in the range 3-6 MIPS

In addition, there is a variety of other computer systems which have operational capability in the 1-4 MIPS range.

Cost estimates for machines in this capability range can only be made in conjunction with a detailed configuration study. In spite of this, however, our experience with large-scale systems suggests the following guidelines for complete computer systems of particular MIPS capabilities:

2-3 MIPS:	$\$1-2 \times 10^6$
3-5 MIPS:	$\$2-3 \times 10^6$
4-6 MIPS:	$\$3-4 \times 10^6$
6-15 MIPS:	$\$6-8 \times 10^6$

The actual cost for a general purpose computer system depends on the particular memory components selected, the input/output channels used, and the complement of peripheral storage.

The special-purpose hardware costs are (as pointed out in sec. 2.3) a relatively small fraction of the general-purpose system costs; typical special-purpose equipment is estimated to cost approximately \$100K per processor (fully equipped with appropriate interfaces, etc.). It is not known at this time whether single or multiple special-purpose processor systems will be necessary; this point is also a subject for further investigation.

3 DATA SYSTEMS ELEMENT (DSE) PROCESSING

3.1 INTRODUCTION

This section reviews an analysis of the existing data systems element (DSE) presently under operation at the Goddard NDPF. This system is used as a base line from which the computational requirements necessary to support the proposed new system configurations are extrapolated.

As envisioned, the major computational functions of the present DSE will be retained, but will be folded into the Operations Control Center (OCC) and image data processing facility (DPF). More specifically, the OCC will handle data collection system (DCS) processing and master digital data (MDD) generation while the DPF will handle actual image annotation and control processing. These functions, their requirements and interfaces, are reviewed in the subsequent discussion.

In this allocation of processing responsibility, the primary interface between the OCC and DPF will be an attitude-ephemeris tape, containing the spacecraft attitude, ephemeris and sensor telemetry (processed to engineering units) in time order for the times of sensor operation. Attitude accuracy, telemetry granularity and sensor operation will determine the time granularity of data on this interface tape and the amount of "bracketing data," if any, required for attitude smoothing or sensor transient observation. Thus, the OCC will produce reduced telemetry and attitude data while the DPF will maintain the capability needed to process image data (such as to locate frame centers and tick marks in film recorder units). This processing in the DPF is also exercised when data is rerun as when using ground control points, and is not run in image time order.

This discussion is divided into two sections: the first provides a brief overview of the total DSE including hardware and software (informational and computational); and the second reviews the operational requirements of the image annotation and data collection computational

software in more depth. This latter review includes the memory and minimum number of magnetic tape units required; the disc space allocated; approximate running times and execution rates to support various levels of production throughput; and, finally, estimates of instruction executed for key subroutines to facilitate adjustments to execution rates for system alternatives that might not require specific types of annotation data.

3.2 OVERVIEW OF THE GODDARD DSE

The operational DSE at Goddard performs the following major functions:

1. Generation of master digital data tapes (MDDT) containing the basic data required for image annotation tape (IAT) production. This data includes: spacecraft attitude, sensor performance and ephemeris information extracted from the spacecraft performance data tape (SPDT) and best fit ephemeris tape (BFET) supplied by the Operations Control Center (OCC) and Orbit Determination Group (ODG) respectively.
2. Generation of IATs containing data used in the image processing element of the DPF for image location, annotation, and correction. A daily image annotation tape (DIAT) containing individual IATs for each day's operation is also produced and used for archival storage.
3. Data collection system (DCS) information processing and generation of user products (cards, listings, tapes).
4. Copying of computer compatible tapes (CCT) containing digital imagery data.
5. Generation of internal work orders used in scheduling and controlling MDDT, IAT, DCS, CCT, and user product processing and production.
6. Internal production accounting and reporting, quality control, etc.

All these functions are performed on a single XDS Sigma 5 computer having an 84^k memory* together with 3 disk-drive and 10 tape-drive units. A configurational overview of the hardware is given in fig. 11. Operating personnel consists of 7 men working 3-2-2 per shift.

The DSE software is divided into two basic subsystems: (1) an information subsystem, and (2) a computational subsystem. The first deals primarily with data storage and retrieval, production control, management reporting, and services to users. The second deals with the computations, editing, and formatting required for production of master digital data tapes, image annotation tapes, and data collection system products.

The information subsystem itself is divided into some nine basic load modules. These and their major functions are summarized in table 9. Similarly, the computational subsystem consists of the five load modules outlined in table 10.

From an external functional point of view, the DSE operates as a set of activities processed by an ERTS monitor. These activities correspond to subroutines comprising the various load modules as outlined in tables 11 and 12. The ERTS monitor utilizes DSE (i.e., the Command Language Module primarily) and the XDS software to read, interpret, and respond to control cards, or interactive commands controlling execution of these activities.

Two modes of operation can be controlled through the ERTS monitor; batch processing (BPM) and interactive processing (BTM). Batch processing runs in the background environment of memory ($\sim 44^k$ allocated), and interactive processing in the "time sharing" environment ($\sim 20^k$ allocated) as shown in fig. 12. The remaining core is allocated to systems software.

* $1^k = 1024$ words of 32 bits each.

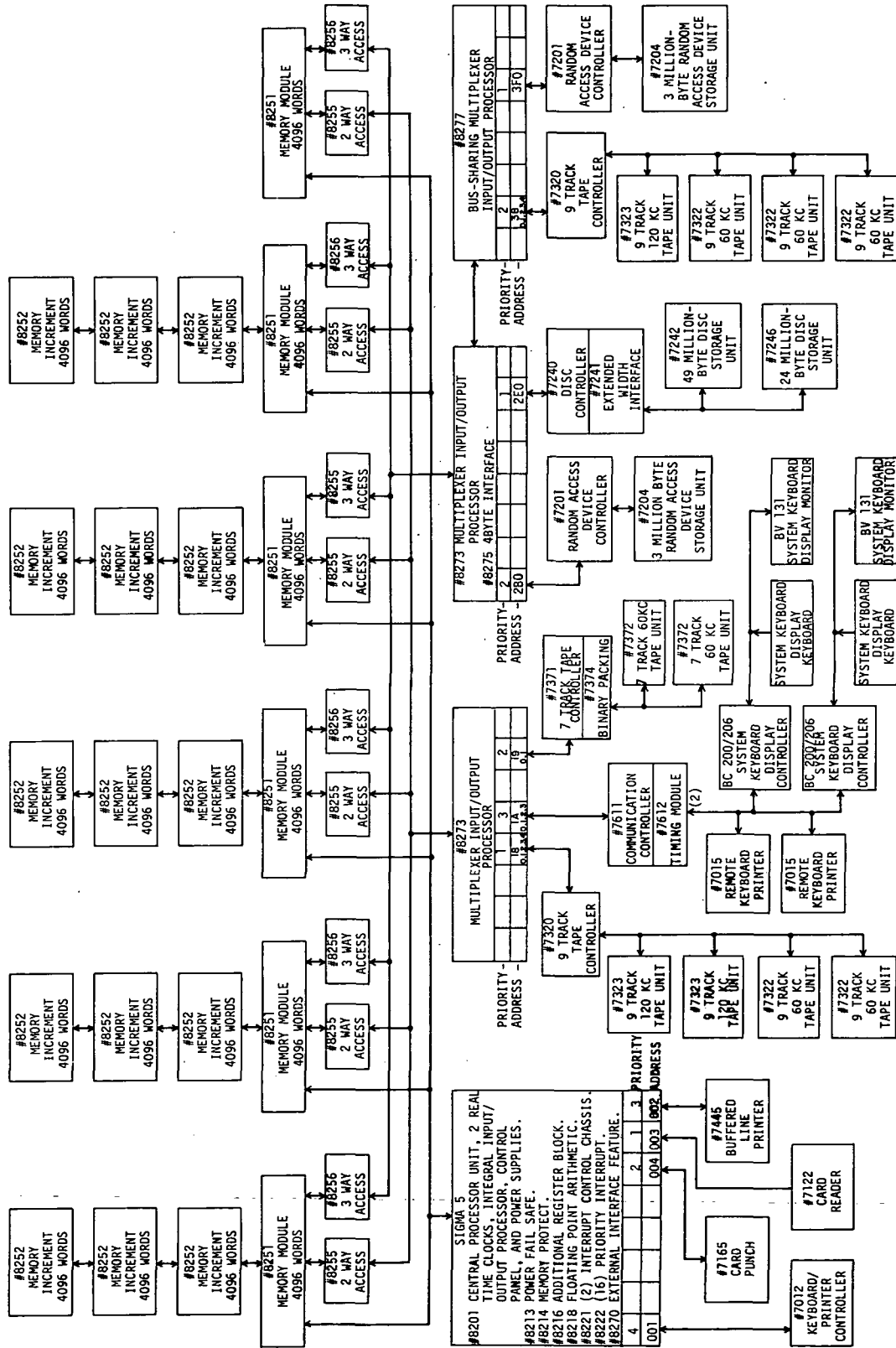

Figure 11. Overview of the XDS Sigma 5 System Configuration

Figure 13 illustrates the flow of data and how activities are used in the BPM and BTM environments. Note that the systems software is stored on disc and activities are called into memory only as needed.

The "data base" shown in fig. 13 consists of some 23 separate data files stored on disc. These files, including granules of allocated storage are summarized in table 13. Access to the files is accomplished through the maintenance module activities (table 9).

3.3 DSE COMPUTATIONAL SUBSYSTEM SOFTWARE

This section reviews in more depth the major operational requirements and characteristics of the DSE computation subsystem software. The emphasis is on identifying and summarizing the requirements of each of the major DSE computational functions including:

1. Master digital data generation
2. Image annotation data generation
3. DCS processing

Discussed are the various algorithms and computations performed; the kinds of data produced; and the computer resources required including core, magnetic tapes, disc files, running times and execution rates for various levels of throughput, and instruction estimates for key subroutines to facilitate adjustments.

3.3.1 Operational Summary

Table 14 summarizes the computer resources required for production of master digital data, image annotation data, and DCS products based on the XDS Sigma 5 system at Goddard. The table provides the background

TABLE 9
LOAD MODULES COMPRISING EXISTING DSE SOFTWARE
(INFORMATION SUBSYSTEM)

LOAD MODULE	MAJOR FUNCTION
Command Language	Interfaces XDS System Software and Application Modules
File Maintenance	Accesses and Updates Data Base Files
Query Support	Provides Current Production and Available Imagery Reports
Retrieval Support	Determines Available Imagery Corresponding to User Requirements
Input Module	Indicates Availability of Input Tapes, Keeps Track of Prepared Image Data and User Request Information
Production Control	Produces Work Orders For All Production Work, and Shipping Orders for Finished Products
Catalog Material	Produces Standard and Image Descriptor Catalogs
Management Report	Produces Management Reports Including Current Processing, Historical Statistics, Image Generation Summaries
Utility Module	Creates and Saves ERTS Data Base and System Files

TABLE 10
LOAD MODULES COMPRISING EXISTING DSE SOFTWARE
(COMPUTATIONAL SUBSYSTEM)

LOAD MODULE	MAJOR FUNCTION
Master Digital Data Generation	Produces Master Digital Data Records for Use in Image Annotation Processing
Image Annotation Generation	Produces Image Annotation Data Records for Use in Image Processing
Data Collection System	Processes DCS Platform Data and Produces DCS User Products
Photographic Quality Control	Provides Interactive Support to Photographic Facility for Computing Gammas, Film Speeds, etc.
Digital Product Preparation	Copies Computer Compatible Tapes (CCT) Containing Digital Imagery Data

TABLE 11
 INFORMATION SUBSYSTEM MAJOR ACTIVITIES

MODULE	ACTIVITY	CORE REQ'D.	DESCRIPTION
Input Module	IADRES	19 ^k	Input user address entries
	IADTAK	21.5 ^k	Take entries out of annotation data file
	IASSES	16.9 ^k	Input image assessment data
	ICALUP	17.9 ^k	Remote batch call
	IMGDSC	20.5 ^k	Input image descriptors
	IPRCMP	18.9 ^k	Terminate work orders
	IRECED	24.5 ^k	Input data received entries
	IREQES	25 ^k	Input data request entries
	IROLLN	35.8 ^k	Input roll number
	ISATCV	23 ^k	Input satellite coverage entries
	ISHPED	25 ^k	Input data shipped entries
	ISTDOR	22.5 ^k	Input standing order entries
	ITEST	25 ^k	Test of best generation inputs
	Product Control	PETBPR	17.9 ^k
PROBAT		25.6 ^k	Produce bulk annotation tape work orders
PROIMG		19.4 ^k	Produce image generation work orders
PROWDR		29 ^k	Produce data request work orders
PROWUP		29 ^k	Produce user profile work orders

TABLE 11 (cont.)
 INFORMATION SUBSYSTEM MAJOR ACTIVITIES

MODULE	ACTIVITY	CORE REQ'D.	DESCRIPTION
Management Report	LIMGEN	16.4 ^k	Produce image generation report
	LHDSHU	14.8 ^k	Produce historic data shipped to users
	LHRSTT	15.4 ^k	Produce historic request statistics
	LPHTIN	13.8 ^k	Produce photographic inventory
Utility Module	LPROFL	14.3 ^k	List user profiles
	LSTUSR	21 ^k	Produce status by user report
	UINITL	8.7 ^k	Initial files
	ULISIF	9.7 ^k	List files
	USAVEF	14.3 ^k	Save files
	URESIF	10.2 ^k	Restore files
	UMODIF	8.2 ^k	Modify file words
	CABCAT	23 ^k	Produce standard catalog
	CMICRO	35 ^k	Produce microfilm work orders
	CMONTG	18.4 ^k	Produce catalog montage listing
CSHCAB	12.3 ^k	Produce shipping labels	

TABLE 12
 COMPUTATIONAL SUBSYSTEM MAJOR ACTIVITIES

MODULE	ACTIVITY	CORE REQ'D.	DESCRIPTION
Master Digital Data Generation	WIMDDG	26.1 ^k	Runs master digital data file generation
Image Annotation Generation	AIBIAT	38.4 ^k	Produce bulk image annotation tapes
	AIPIAT	24.1 ^k	Produce precision image annotation tapes
	AISIAT	24.1 ^k	Produce special image annotation tapes
Data Collection System Processing	DPROCS	23 ^k	DCS processing and generation of DCS user products
	DDDUMP	Total	Daily DCS dump
Photographic Quality Control	YPHOTO	-----	Photographic quality control support
Digital Product Preparation	TAPBAK	-----	Copy CCT in background

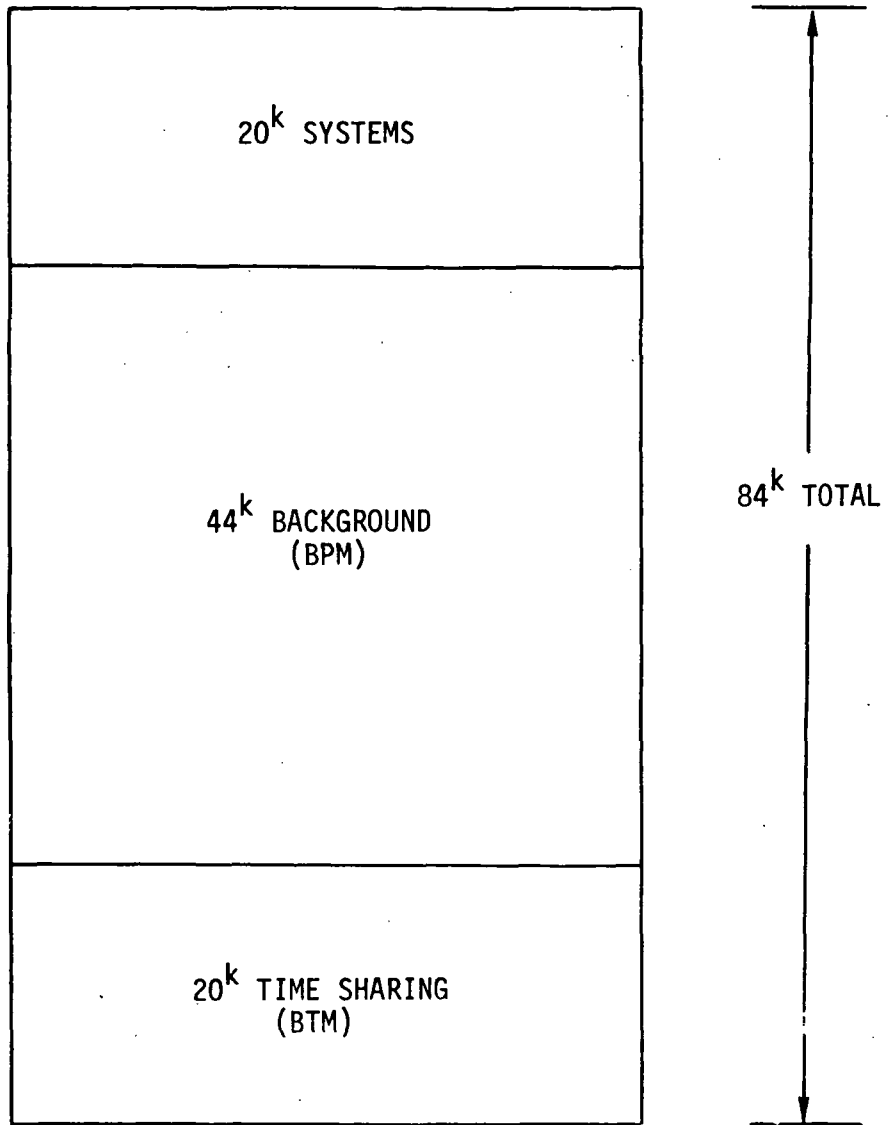

*1^k = 1024 words of 32 bits each.

Figure 12. Present DSE Sigma 5 Core Utilization
(BPM/BTM XDS Operating System)

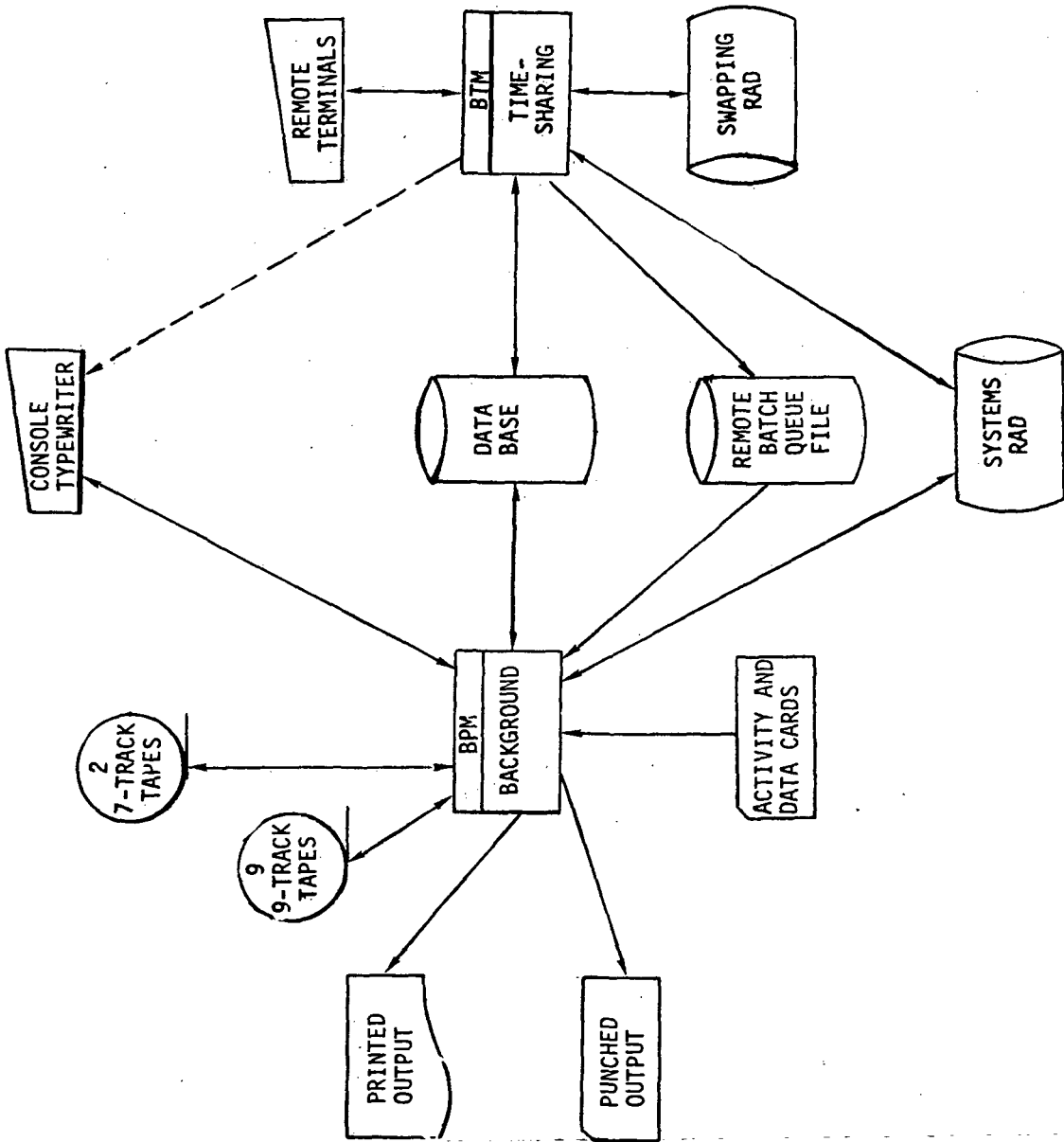

Figure 13. Flow of Data in the BPM/BTM Environment

TABLE 13
PRESENT DSE DATA BASE DISC ALLOCATION

FILE NAME	DESCRIPTION	GRANULES*
FADF	Active Data File	2500
FADR	User Address File	102
FCAL	Calibration Values	3
FCMF	Catalog Maintenance	16
FCOV	Satellite Coverage	600
FDPR	Delayed Print	512
FHST	Historical Statistics	870
FIAD	Annotation Data	396
FIAT	Image Annotation Tape	1280
FIMG	Main Image	6000
FMDD	Master Digital Data	3840
FMST	Master Index Granule	1
FPID	Platform ID	2
FPRF	User Profile	1040
FPSF	Swath File	600
FREC	Data Received	12
FREQ	Data Request	674
FRIM	Rejected Image	134
FROL	Archival Roll	269
FSCR	Scratch File	256
FSRF	Standing Request	50
FWRK	Work Order	768
SORT	Temporary Work	3
		19928 TOTAL

* 1 granule = 512 words of 32 bits each.

core and minimum number of magnetic tape units (MTU) required, the disc space allocated, and approximate running times averaged over a number of actual production runs.*

As shown, running times are broken down into execution, input/output (I/O), and overhead. One can interpret this breakdown as follows:

Execution time: time during which the central processing unit (CPU) is executing the computational or logical segments of a given program.

Input/output (I/O) time: time during which the CPU is spent in loops waiting for completion of an I/O operation (measured from the start of I/O command). This time represents the penalty incurred due to incompatibility between the CPU execution rates, and I/O device cycling rates because overlapping (I/O scheduled to allow concurrent I/O and computing) has not been or cannot be designed into the program.

Overhead time: time the monitor spends preparing to issue an I/O operation. This includes time required for tape changing, etc.

Note from table 14 that, in general, I/O and overhead times are relatively large compared to actual execution. Clearly, the processing throughput for each major function is I/O bound, and the CPU is not being used to its fullest capacity. Reflected therein is nonoverlapped time, which is expended in updating files on disc, reading and writing tapes, card punching, etc., all of which comprise a significant portion of the related activities and subroutines.

* Master digital data times were found to be slightly sensitive to the number of SPDT/BFET tapes edited. Likewise, image annotation generation times were somewhat sensitive to the number of scenes processed per logical BIAT; and DCS processing to the number of messages per data collection system tape and the nature of the user products generated. In each case, the variation from the average recorded in table 14 was nominal and not significant considering the order of magnitude estimates desired here.

TABLE 14
DSE COMPUTATION SUBSYSTEM: SUMMARY OF COMPUTER RESOURCES REQUIRED

MAJOR FUNCTION ¹	BPM CORE REQUIRED ²	MINIMUM MTU REQUIRED	DISC SPACE ALLOCATED FILE NAME	APPROXIMATE RUNNING TIME ³ EXECUTION	APPROXIMATE RUNNING TIME ³ I/O OVERHEAD
Master Digital Data (MDD) Generation	26.1 ^k	2	FWRK	0.11 min/ scene	0.1 min/ scene
			FCOV		
			FREC		
			FIAT		
			FMOD		
Image Annotation Generation	38.4 ^k	3	FMDD	0.025 min/ scene	0.15 min/ scene
			FIAT		
			FWRK		
			FCOV		
			FIAD		
Data Collection System (DCS) Processing	23 ^k	1	FPID	0.0025 min/ message	0.025 min/ message
			FADF		

¹In the proposed mission configurations (sec. 2.4), MDD and DCS processing will be handled by the OCC, while image annotation generation will be absorbed into the DPF.

²Includes ~9^k for ERTS monitor, where 1^k = 1024 words of 32 bits each.

³Running times are for the XDS Sigma 5 system.

The ultimate objective in identifying the requirements outlined in table 14 is to establish a base line from which the computer resources required to support the computational and annotation requirements of the image processing alternatives might be extrapolated. To facilitate this, it is convenient to express processing requirements in terms of instruction execution rates (MIPS) required to support various levels of production throughput.

Knowing the execution rate of the XDS Sigma 5 processor and also the Sigma 5 execution times given in table 14, one can estimate processor execution rates required for various levels of throughput, using

$$\dot{R} = 6.9(10)^{-4} \dot{R}_{\Sigma 5} T_E \dot{Q} \quad (\text{MIPS})$$

where $\dot{R}_{\Sigma 5}$ = execution rate of the Sigma 5 (~1 MIPS)

T_E = Sigma 5 execution time for one unit of throughput obtained from table 14 (minutes per scene or minutes per message)

\dot{Q} = units of throughput per day (scenes per day or messages per day)

This operation is summarized in table 15 for the range of throughputs of interest to this study.

In reviewing table 15, one should note that the numbers given represent at best a low estimate of the MIPS required. They presume a fully available, fully utilized CPU that is not limited by memory, I/O, or human operator. The numbers, therefore, are useful in establishing relative orders of magnitude or in forming a basis for more detailed estimates that would consider these other interfaces as well.

The remaining pages of this section concentrate more specifically on the computational algorithms, including kinds of data produced, for

master digital data and image annotation generation. The intent is to provide a basis for adjusting the MIPS estimates given in table 15, if it is established at a later date that a given image processing alternative does not require some specific class of data (i.e., annotation, sensor, or geometric correction). This can be done using

$$\dot{R}_A = \dot{R}_1 \pm 1.15 \times 10^{-4} \dot{I} \dot{Q}$$

where \dot{R}_1 = execution rate given in table 15 (MIPS)

I = millions of added or deleted instructions required for one unit of throughput (a scene or message)

Q = units of throughput per day (scenes per day or messages per day)

More specifically, then, the objective in what follows is to establish representative values of "I" presently required to produce the major types of annotation data.

3.3.2 Master Digital Data (MDD) Generation

The purpose of the master digital data module is threefold:

1. To retrieve satellite ephemeris and telemetric data for the spans of time during which the video sensors were operating
2. To derive spacecraft altitude and attitude from this data
3. To write the combined telemetry/ephemeris data for just the time spans of interest onto magnetic tape and disc for use in generating image annotation information at a later time (sec. 3.3.3)

The primary inputs to the module include:

TABLE 15
 SUMMARY OF ESTIMATED PROCESSING MIPS
 (COMPUTATIONAL SUBSYSTEM)

MAJOR FUNCTION *	MIPS REQUIRED vs. PRODUCTION THROUGHPUT			
	100 Scenes/day	200 Scenes/day	400 Scenes/day	
Master Digital Data Generation	0.0069	0.0138	0.0276	
Image Annotation Generation	<u>0.0017</u>	<u>0.0034</u>	<u>0.0068</u>	
TOTAL	0.0086	0.0172	0.0344	
	<u>1000 Messages/day</u>	<u>2000 Messages/day</u>	<u>4000 Messages/day</u>	
Data Collection System Processing	0.0017	0.0034	0.0068	

* In the proposed mission configurations (sec. 2.4) MDD and DCS processing will be handled by the OCC, while image annotation generation will be absorbed into the DPF.

Spacecraft Performance Data Tape (SPDT): This tape, supplied by the OCC, contains enhanced spacecraft telemetry data in 16-s blocks of time called master frames. For each master frame, the data is stored in an "enhanced telemetry matrix" at rates varying between 1 and 16 samples per master frame depending on the function monitored. This data includes: attitude measurement system (AMS) voltages and sensor temperature; RBV exposure times and duration of exposures for each band; MSS on/off times, MSS sensor operating voltage levels, and gains for each band; MSS transmission mode (i.e., compressed or linear); and other spacecraft telemetry functions.

Best Fit Ephemeris Tape (BFET): This tape, supplied by the orbit Determination Group, contains ephemeris data covering a 2-day period. The data is grouped into 60 sec records each preceded by title information that includes orbital parameters and time spans, and then at 1-s intervals basic data that includes: spacecraft positional information in earth-centered Cartesian coordinates; spacecraft nadir in geodetic latitude and longitude coordinates; and local sun azimuth and elevation at the nadir.

MDDT Work Orders: These work orders, generated by the production control module, contain time intervals of video coverage for a given wide-band video tape (WBVT) and the corresponding SPDTs and BFETs identification codes.

The primary outputs of the module are an MDD file (FMDD) and tape (MDDT) which contain data in 16-s master frame records corresponding approximately to the time spans of video coverage.* In each record, the entire enhanced telemetry matrix from the SPDT is extracted and recorded. Also recorded at 1-s intervals is data that includes: the spacecraft

* Since one video coverage interval is 25-s, two 16-s master frames would be required per scene unless scenes were continuous, in which case data overlap would occur at the ends only.

position (earth-centered Cartesian coordinates), local sun azimuth and elevation at the nadir, and computed spacecraft altitude and attitude.

The four major subroutines that make up the module are described below:

WIMDDG - This is the executive and driving routine of the module. For a given MDDT work order, this routine identifies the next SPDT to be processed (i.e., there may be one or more corresponding to a given WBVT) and pairs it with the corresponding BFET. The WIEDIT, WIALT, and WIATT routines are then called, and the SPDT/BFET combination is processed. After completion of the last SPDT, the current MDDT work order is deleted and the FMDD file is copied from disc onto the master digital data tape.

WIEDIT - This routine extracts SPDT enhanced telemetry data and BFET positional data for each WBVT observation time given in the input MDDT work order. The data is processed and edited one master frame at a time. Briefly the procedure is as follows: the SPDT and BFET are searched until the desired master frame corresponding to the next time span of video coverage is found. The enhanced telemetry matrix and ephemeris data for the 16-s master frame interval is then read. AMS attitude voltage data is then extracted from the enhanced telemetry matrix and, for each 1-s interval in the master frame, converted to satellite attitude in degrees, using the routine WIATT. Likewise, the routine WIALT determines satellite altitude for each 1-s interval, using ephemeris data. The FMDD file is then updated with one record containing the enhanced telemetry matrix, ephemeris data, and computed spacecraft attitudes and altitudes corresponding to the master frame. The procedure is then repeated until all master frames for the WBVT time spans have been covered.

WIALT - This routine computes satellite altitude or height above an earth-reference ellipsoid (measured normal to the ellipsoidal surface), using BFET earth-centered rectangular coordinate data and an assumed earth model. The computation is a simple evaluation of a closed-form equation.

WIATT - This routine converts SPDT AMS voltage data into satellite attitude measured in degrees. The procedure is complex in that there is no direct closed-form method for computing attitude from AMS sensor output. Rather, an iterative method is used that can be summarized as follows. The telemetered AMS outputs are used to obtain approximate attitude angles. These angles are then input to a mathematical model,^{*} giving expected AMS sensor outputs which are compared with the actual (telemetered) values. If they are within predefined convergence criteria, the assumed attitude angles are taken to be actual. Otherwise, the approximate attitude is corrected and the procedure repeated until the convergence criteria are met.

In the above review, one will note that considerable effort is expended searching tapes and disc files and transferring data (which for the most part remains unchanged) to other disc files and tapes. The only real computational processing performed is the altitude and attitude calculation. In this regard it is conceivable that the image processing alternatives may require reduced attitude and altitude information (e.g., > 1-s intervals) or perhaps, because the attitude control is more precise, less cycling may be required in the AMS convergence calculations. In any case, if one is to make adjustments to the processing MIPS recorded in table 15, it is useful to have estimates of the numbers of instructions executed in performing these calculations. Table 16 provides

*The "Quantic Model" developed by Quantic Industries, Inc., manufacturer of the AMS sensor.

such estimates; they were obtained from a review of the available software documentation. One should note that in the proposed mission configurations (sec. 2.4) MDD generation will be retained but will be folded into the OCC.

3.3.3 Image Annotation Generation

The function of the image annotation module is to provide the data required for identification, geometric correction, location, and annotation of images recorded on the wide-band video tapes.

The primary input to the module is the master digital data file (FMDD) produced by the MDD module (sec. 3.3.2).^{*} Recall that this file contains chronologically ordered satellite ephemeris, telemetry, altitude, and attitude data (corresponding to each WBVT observation).

The primary outputs of the module are image annotation tapes that include: (1) a daily tape (DIAT) containing bulk, precision, and digital annotation files for all scenes of an operational day arranged chronologically; (2) a logical bulk image annotation tape (BIAT) for each video tape pair (MSS and RBV) processed;^{**} (3) a precision image annotation tape (PIAT) containing annotation data only for the included scenes to be processed; and (4) a special image annotation tape (SIAT) for processing digital imagery products.

* In the normal processing flow, the master digital data tape is not used because the data it contains is on disc (FMDD) during the time that processing is taking place. If some portion of the processing is to be rerun after the FMDD has been purged from the disc, the contents of the MDTT are copied into the file.

** The term "logical" BIAT represents an image annotation tape for one video tape pair. As many as nine logical BIATs may be written onto a single physical tape reel, separated by double end of file marks.

TABLE 16
ESTIMATED INSTRUCTIONS EXECUTED FOR MAJOR CALCULATIONS

FUNCTION	SUBROUTINE	ESTIMATED INSTRUCTIONS EXECUTED	CALCULATION
Master Digital Data Generation	WIALT	1000	Per Ephemeris Data Point Satellite Altitude
	WIATT	20,000	Per AMS Data Point Satellite Attitude (pitch, roll, yaw)
Image Annotation Generation	AINTR	2000 (Average)	Per Calculation for 27 Point: Linear Interpolation Quadratic Interpolation Cubic Interpolation
	AICNTR		Per Point on the Image Plane Conversion to Earth Geodetic Coordinate Location

The general format for each annotation tape is shown in fig. 14. The "header file" contains specific annotation and WBVT tape identification and processing information. Following are separate data files for each scene that varies slightly in character, depending on the type of tape discussed. Typically, a scene file is blocked into six records containing the data summarized in table 17.

The major subroutines that make up the module are described below.

AIBIAT: This is the executive or driving routine of the module. One of four entry points is used, corresponding to the type of tape requested by the operator. In general "precision" and "special" annotation processing extract scene data already available on DIATs produced earlier. For these cases very few additional calculations are performed. Consequently, the more computationally significant mode of operation for this module is the generation of BIATs and DIATs. This is accomplished by cycling through scenes and calling each of the subroutines that follow in approximately the order discussed. These subroutines produce the annotation, location, and computational data which are stored on temporary files. Once all scenes corresponding to a video tape pair have been generated, the last routine, AIDIAT, directs production of a BIAT and at the end of an operational day, a DIAT.

AISAT: For each scene processed, this subroutine extracts sensor code information (see table 17) from the enhanced telemetry matrix of the FMDD file. It also extracts RBV exposure and MSS on/off times from the satellite coverage file (COV) and converts these from spacecraft (S/C) time to Greenwich Mean Time (GMT).

AIFRAM: This subroutine frames MSS video data to correspond to RBV exposures such that the format center of MSS images will coincide with the format centers of RBV images. Normally, the RBV sensor takes photographs every 25-s during an operational interval. At the same time the

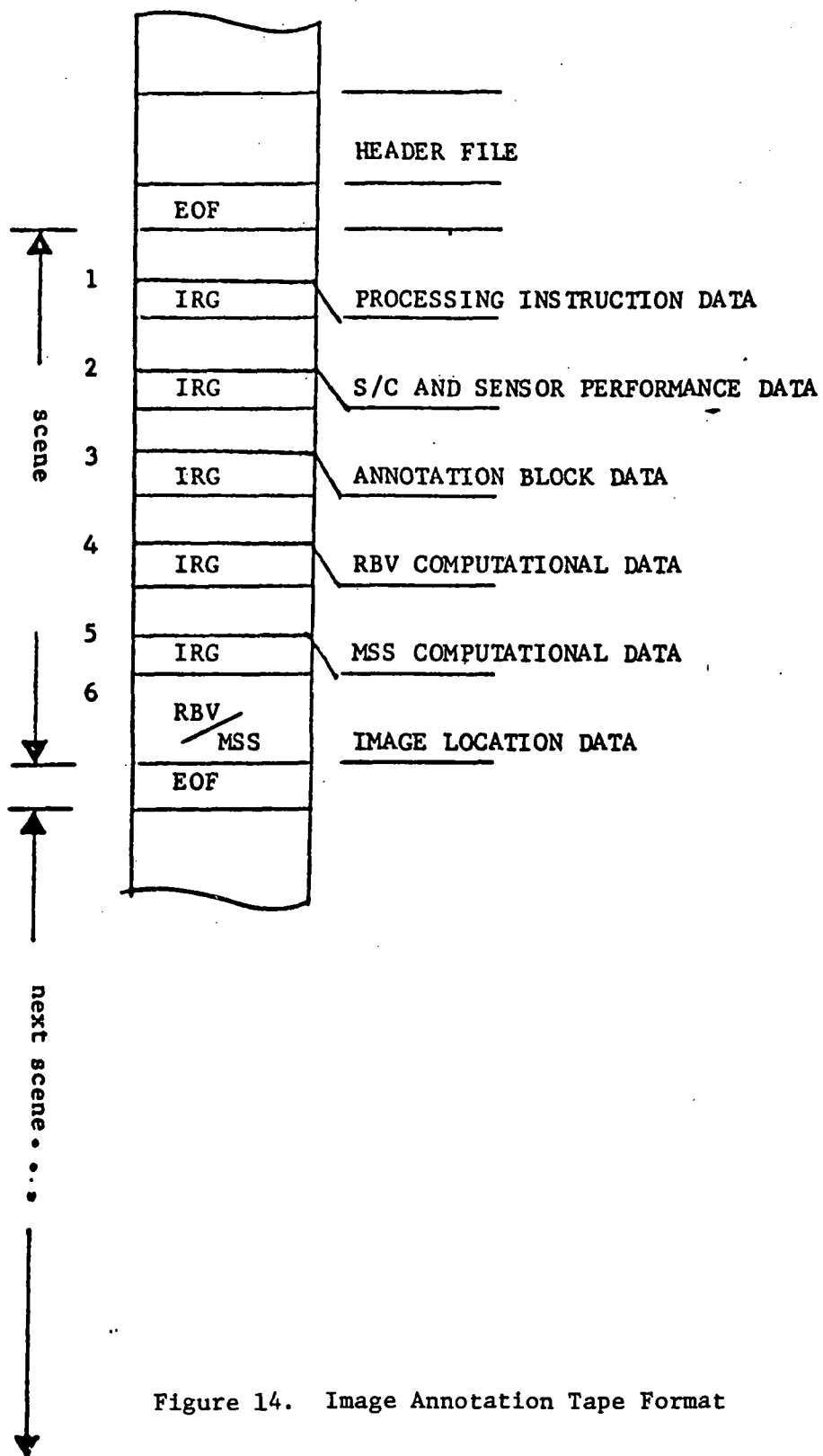

Figure 14. Image Annotation Tape Format

TABLE 17
IMAGE ANNOTATION TAPE

RECORD	DATA STORED	MAJOR SUBROUTINE EXECUTED	GENERAL PROCEDURE
1. <u>Processing Instruction Data</u>	General Processing Information provided image or special processing operator - varies with type of tape	---	Information extracted from work order
2. <u>Sensor Code Data</u>	Sensor Type (RMV, MSS) Spectral Band Mode of Transmission/Band REV Shutter Setting/Band REV Exposure/Band REV Aperture Correction Indicator/Band MSS Gain/Band (High, Low) MSS Sensor Encoding/Band (Linear or Compressor) SPDT Tape Identifier	AISAT AISAT AISAT AISAT AISAT AIMDFR AIMDFR AIEXTR	↑ FMDD and FCOV Lookup ↑ FMDD Lookup FMDD Lookup FMDD Lookup
3. <u>Annotation Block Data</u> Human readable annotation format	Day/Month/Year of Exposure Latitude & Longitude of Image Center Time (ICT) Latitude & Longitude of Nadir Sun Elevation and Azimuth at Nadir Satellite Heading and Track Revolution Number Ground Recording Acquisition Site Frame Size Type of Orbit Data Frame Identification Radiometric Calibration Exposure Levels REV Mode, Shutter Setting, Aperture Correction Indicator & Band (Special Processing Only) MSS Mode of Transmission (Special Processing Only)	AISAT AICNTR AIEXTR/AINTR AIEXTR/AINTR AIH0TR AISAT AISAT AIFRAM AIFRAM AIFRAM AIFRAM AISAT AISAT	FMDD Lookup See text FMDD Lookup & Linear Interpolation FMDD Lookup & Linear Interpolation See text FMDD Lookup FMDD Lookup FMDD Lookup FMDD Lookup & Reformat FMDD Lookup FMDD Lookup FMDD Lookup

TABLE 17 (Cont.)

IMAGE ANNOTATION TAPE

RECORD	DATA STORED	MAJOR SUBROUTINE EXECUTED	GENERAL PROCEDURE
4. <u>RBV Computational Data</u>	<p><u>BULK</u></p> <p>Spacecraft (S/C) and Greenwich Mean Time (GMT)</p> <p>Normalized Altitude Change from Nominal at ICT</p> <p><u>PRECISION</u></p> <p>GMT Date of Exposure</p> <p>GMT Time of Exposure</p> <p>Latitude & Longitude at ICT</p> <p>Latitude & Longitude of Nadir at ICT</p> <p>Spacecraft Altitude at ICT</p> <p>S/C Flight Path Heading & Track at ICT</p> <p>S/C Pitch, Roll, and Yaw at ICT</p>	<p>AIFRAM</p> <p>AIEXTR/AINTR/AIBIAT</p> <p>AIFRAM</p> <p>AIFRAM</p> <p>AIEXTR/AINTR</p> <p>AIEXTR/AINTR</p> <p>AIEXTR/AINTR</p> <p>AIEXTR/AINTR</p> <p>AIHDR</p> <p>AIEXTR/AINTR</p>	<p>File Search and Comparison</p> <p>FMDD Lookup, Quadratic Interpolation</p> <p>File Search and Comparison</p> <p>File Search and Comparison</p> <p>FMDD Lookup & Linear Interpolation</p> <p>FMDD Lookup & Linear Interpolation</p> <p>FMDD Lookup & Quadratic Interpolation</p> <p>Evaluate Two Geometric Equations</p> <p>FMDD Lookup & Linear Interpolation</p>
5. <u>MSS Computational Data</u>	<p><u>BULK</u></p> <p>S/C & GMT at ICT</p> <p>Normalize Altitude Change from Nominal</p> <p>S/C Altitude</p> <p>S/C Attitude (roll, pitch, yaw)</p> <p>Image Skew Associated with Earth Rotation</p> <p>Normalized Delta Velocity Over 27.6 sec Centered About ICT</p> <p><u>PRECISION</u></p> <p>Mean Pitch, Roll, Yaw over ±13 sec from ICT</p> <p>Mean Pitch, Roll, Yaw Rates Over ±13 sec From ICT</p> <p>Mean S/C Altitude at ICT</p> <p>Mean S/C Altitude Rates at ICT</p> <p>GMT</p> <p>Nadir Latitude</p> <p>Nadir Longitude</p> <p>S/C Altitude</p> <p>At ICT ±0, 5, 10 15, 20, 25 sec</p>	<p>AIEXTR/AINTR/AIBIAT</p> <p>AIEXTR/AINTR</p> <p>AIEXTR/AINTR</p> <p>AIBIAT</p> <p>AIEXTR/AINTR/AIBIAT</p> <p>AIEXTR/AINTR</p> <p>AIEXTR/AINTR</p> <p>AIEXTR/AINTR</p> <p>AIEXTR/AINTR</p> <p>AIEXTR/AINTR</p> <p>AINPOS/AICNTR/AITICK</p>	<p>File Search and Comparison</p> <p>FMDD Lookup & Quadratic Interpolation</p> <p>FMDD Lookup & Quadratic Interpolation</p> <p>FMDD Lookup & Cubic Interpolation</p> <p>Evaluate Single Geometric Equations</p> <p>FMDD Lookup & X, Y, Z Linear Interpolation Including Derivatives</p> <p>FMDD Lookup & Linear Interpolation</p> <p>FMDD Lookup, Linear Interp., Derivative</p> <p>FMDD Lookup, Quadratic Interpolation</p> <p>FMDD Lookup, Quad. Interp., Derivative</p> <p>FMDD Lookup & Linear Interpolation</p> <p>See Text</p>
6. <u>Image Location</u>	<p>Tick Mark Location (Latitude/Longitude) and Annotation Contained in Various Tick Mark Tables</p>		

MSS is scanning continuously over the same terrain. Framing consists of searching for overlapping intervals between the RBV and MSS, and then adopting the RBV shutter time as the image center time (ICT). When MSS coverage does not overlap RBV images (as in ERTS-1, after the RBV operation was terminated) the ICT is chosen at 25-s intervals starting with MSS on-time (allowing for a 50-s sensor warm-up period) plus 12.5-s. Once the ICT has been so defined, it is used frequently as a reference point in subsequent calculations. It is also used for scene identification and other annotation block data as shown in table 17.

AIEXTR/AINTR: These subroutines are normally used in sequence. AIEXTR extracts ephemeris, attitude, and other data from the FMDD file and AINTR is used to interpolate between data points with an unlimited point, least square polynomial algorithm. Interpolation is generally necessary since the times (ICT, etc.) when data are required will not normally agree exactly with available ephemeris, altitude, and attitude data stored at 1-s intervals in the FMDD. These two subroutines are used to determine a large portion of the computational data and also some portions of the annotation block data as shown in table 17.

AIHDTR: This subroutine is used to compute satellite heading and subsatellite track at the ICT. The computations require straightforward solutions of two closed-form equations.

AICNTR: This subroutine is used to calculate the geodetic latitude and longitude coordinates of the ICT and also tick marks that locate the image on the earth. More specifically, the routine relates a point in the image plane of a camera to a point measured in latitude and longitude on the surface of a rotating earth model. The basic mathematical model and procedure used are rather complex and require solutions to a number of equations.*

*The method is derived from a paper by R. G. DeBiase "Gridding of Satellite Observations," J. Spacecraft, Vol. 1, No. 2, March-April 1964.

AINPOS/AITICK: Before tick marks for an observation can be computed, an altitude adjustment is made using AINPOS. This routine moves the spacecraft up or down the yaw axis until the distance from spacecraft to ICT is equal to the nominal altitude (911.83 km) used in bulk-processing scale-correction calculations. AITICK then calculates the latitude and longitude intersections for eight tick-mark points (four image corners and the midpoints of the four sides) at intervals of 30 arc min and prepares tick-mark locations and annotation tables for inclusion in the BIAT under the image location record (table 17).

AIDIAT: This routine is primarily an output utility routine that generates BIATs/DIATs from the image annotation files on disc. The routine formats the data according to the six records of image annotation data per scene (fig. 14) and reads the data onto tape in the same time sequence as the images found on the assigned pair of MSS and RBV tapes.

The above discussion and review of table 17 show that a large portion of the sensor code and annotation data involves simply an FMDD lookup and transfer of information to another file. On the other hand, the RBV/MSS computational and location data requires additional processing which principally involves: AINTR and AICNTR.

It is likely that the image processing alternatives and missions presented in sec. 2.4 may require adjustments to the computational or location data. For example, the Mission 4 alternative (requiring two RBVs) would possibly require changes in the kinds of data needed for annotation, framing, etc. As an aid to making adjustments to the total processing MIPS required for annotation as given in table 15, table 16 provides estimates of the instructions executed for each of the major subroutines. This table can be used in conjunction with table 17 where the subroutines corresponding to the specific data are identified.

Note that, in the proposed mission configuration (sec 2.4) generation of annotation and control data will be folded into the DPF with the MDD tape (from the OCC) serving as an interface.

4 RECORDER SURVEYS

4.1 FILM RECORDERS

The purpose of this section is to review the state of the art in laser beam recorders (LBR) and electron beam recorders (EBR) and assess the feasibility, performance, and estimated costs for a film recorder for each mission configuration in the ERS study. RCA and CBS Laboratories have been contacted within the scope of this study. These two companies have demonstrated competence and experience, and have made commitments to compete in the film recorder market; therefore, we believe that acceptable estimates can be made based on data obtained from these two companies. Recent competitive procurements of EBR's and LBR studies support this choice of contractors to be contacted. This report will not redo the work performed on the ERTS A/B Phase B, C studies on film recorder trade-offs.

4.1.1 Requirements

Requirements of a film recorder can be stated (one of many ways):

1. Spot size, shape, and intensity on the film
2. Accuracy with which a spot can be placed at a desired point on the film
3. Input data rate (or line writing rate, or frame time).
4. Ancillary requirements:
 - Operating mode: continuous or frame
 - Annotation requirements
 - Random spot replacement or raster operation
 - Frame size

Assuming a perfect scanning sensor for discussion purposes, with 3000 samples per scan line and 2600 scan lines per frame, it is obvious that one line must have cross-scan width of $1/2600$ of a frame (else

density could not be sufficiently controlled, and the unexposed film would show up as a distinct line structure). This width can be achieved by the physical size of the spot or by rewriting data with a smaller spot. Rewriting allows better control of the inevitable overlap at the spot edges than can be achieved by writing data with a single spot (of similar energy density). Wobbling the spot can be viewed as a means of rewriting data, or as a spot-shaping method which also controls edge overlap.

Constraints in the scan direction are more difficult to define. If the spot could be stepped and stopped at each of the 3000 data points in the scan direction, and the spot energy exactly controlled, would not be degraded. With any practical system only a finite time can be spent at each position (about 2 μ s for the scanner under discussion--50% duty cycle \times 25 s/number of points, assuming 1:1 record-playback). This time per data point requirement translates into bandwidth requirements for the system from data input to beam intensity at the film. Moreover, if the spot is moving during the data point writing time and the intensity is continuously modulated by the data (as opposed to being modulated in an impulse fashion--very short duration pulses of high intensity), the resultant energy distribution on the film is the convolution of the energy intensity as a function of time with the spot energy density function. Considering this, the same perfection as that of the step-and-stop system could be achieved if a mathematical line segment could be generated--zero width in the scan direction, 1/2600 of a frame in length--with intensity controlled through an infinite-bandpass (noise-free) channel with band-limited data.

As neither perfect system can be obtained (although an EBR might approach the step-and-stop system), finite bandwidth and finite spot size will introduce some degradation into the data. However, bandwidth limitation is not a practical problem for the system of concern; the data must, in fact, be band limited to prevent aliasing effects from the side lobes obtained in the $(\sin x)/x$ frequency function which results

from sampling with a square aperture in the scanner. Spot size is not a significant problem either, as both LBR's and EBR's are capable of writing 8000 to 10,000 spots across a scan line in their respective formats.

Spot placement is currently accurate in available systems to spot diameters of about 0.3 to 0.1. Available systems can easily record the MSS (one band) and RBV data at the sensor output rates. Since RBV data can be accepted, MSS data could be recorded at a rate faster than output from the sensor.

Since spot size, spot placement, and data rate requirements can be achieved by both LBR's and EBR's, we are led to the following conclusion: the ancillary requirements are areas for system design trade-off and will, in fact, determine the film recorder choice for each system. This conclusion is restated in more detail as follows.

No error allocation specifying maximum data degradation has been allowed to occur in various system components, specifically in the film recorder. Requiring, arbitrarily, 90% response at 4000 cycles/line is probably unnecessarily stringent and 25% response at that point unnecessarily lax. Moreover, MTF statements, linearity statements, etc., cannot be separated from each other or from performance against ancillary requirements (e.g., performance in the corner of a writing field is obviously a function of whether the field is an area--framed format--or a line--continuous format). What can be stated is that both EBR's and LBR's can write data on film with a sufficiently small spot sufficiently accurately placed and through a sufficiently responsive system to be acceptable for use with an MSS or RBV data system. This is subjective, based on the capability of each system to place 8000 to 10,000 spots on a line (a disadvantage to EBR's if the 70-mm format must be enlarged to 9 1/2 in for comparison) to an accuracy of 0.1 to 0.3 spot diameters (if random) through a 10-20 MHz system (if necessary). Thus, system design factors such as the following dominate in choosing an EBR or LBR for a specific system:

- Need for 70-mm or 9 1/2-in formats
- Need for geometric correction at the film recorder
- Film type constraints
- Annotation requirements
- Framing requirements for scanner data
- Requirement for correlation between film and digital data

Film transports of interest are of two types: continuous motion and frame advance. Drum and sheet film carriers are not addressed. Continuous-motion film transports depend on smooth, constant film velocity to achieve cross-scan motion. It is generally used with LBR's, and is seen in EBR's with special applications (like the NASA NDPF CBS EBR). In a continuous-motion device, the usual procedure with LBR's is to have a single-line-width writing area which may be straight or curved. Straight fields may require optics to compensate for spot velocity and focusing nonuniformities. Curved fields cause some film stretching, which may be negligible. Film drive is by tension, sprocket and holes, capstan, or capstan and pinch roller. All methods have obvious disadvantages. As the continuous-film-motion systems expose film with a moving spot on moving film, transport jitter, velocity nonuniformities or erratic movement create visible image defects. Unless multiple writing areas are defined, the data must be written on a raster format (i.e., the annotation must be mixed with the image data before writing).

Frame-advance film transports operate by advancing film a certain distance over a short period of time, typically 80 or 90 mm in 100 ms or less. Additional settling time is required. The writing area is usually one full frame of data, so spot velocity control and focus control are required to write over the full area. This method is suited for use in EBR's, and the additional advantage of separately writing annotation and data becomes available to the systems. The same direct film drive can be used, with account taken of inertia, stretching, and the elastic properties of the film.

4.1.2 Electron Beam Recorders

EBR's expose film directly with electrons. The electron spot can be swept, positioned, dynamically focused, and intensity modulated using well-developed electrostatic and electromagnetic techniques. To avoid attenuation and scattering of the electron beam, the path between the electron source and the film must be evacuated (at least 10^{-6} torr is desirable). Problems directly associated with the arrangement of film in a vacuum are:

- . Outgassing from the film (and air trapped in rolled film)
- . Reload and pumpdown time
- . Mechanical interfaces (such as film transport control) crossing the vacuum interface

Other problems with EBR's involve static buildup on film which, when discharged, create "lightning" streaks. Using conductive layer backed film to avoid this problem creates another set of problems.

The electron spot is essentially Gaussian in density, limiting the density shaping achievable. It does not, however, have the side-lobe and diffraction problems of masked light spots as in some LBR's.

The ability to randomly place an electron spot with high precision allows departure from the constraints imposed on raster systems. This permits use of techniques such as

- . Framing of MSS data by rewriting identical data in two frame areas
- . Separate writing of data and annotation (as in the Canadian system)
- . Perturbation to the data raster for geometrical correction

Secondary effects and considerations in specifying EBR's are:

- . Cathode replacement
- . Beam position and intensity detection
- . Dynamic focusing range (format size)
- . Energy density achievable
- . Film constraints

4.1.3 Laser Beam Recorder

LBR's expose film with a modulated laser beam. This beam is scanned across the film by a rotating hologram or mirror, and either the film must be curved or optics used to maintain constant spot velocity on the film. In guiding curved film, some distortion is inevitable, and scratching is difficult to avoid. All LBR's of interest write on 9 1/2-in continuously moving film to avoid moving the rotating scanner or focus over a two-dimensional field. Placement of the spot on the film becomes a matter of timing the data into the LBR, as the LBR is essentially a raster scan device, and, as such, can only place data on the raster. Hence, any cross-scan correction must be made to the data before delivery to the LBR, and correction in the scan direction can be made before delivery or by adjusting the timing of the data into the scan line. All annotation must be processed into the data before delivery to the LBR, again since it is a raster device.

Secondary effects and considerations to be noted in specifying LBR's are:

- . Laser frequency and film sensitivity trade-offs
- . Diffraction from spot-shaping apertures
- . Accuracy between facets on mirrors to avoid easily observable banding
- . Energy scatter from holograms or mirrors

These items are not decisive in comparing LBR's with EBR's.

4.1.4 Primary Factors to be Considered in LBR Versus EBR Trade-Off

Returning to the trade-off between the two concepts, we find characteristics of LBR's and EBR's which have overwhelming system implications: format size (equivalently, MTF on a fixed format size), and flexibility.

LBR's are available to write on 9 1/2-in film. EBR's have only been demonstrated in depth to 70 mm with some experiences at 5-in formats. There have been statements made that 9 1/2-in EBR's are feasible, but these have not been demonstrated and they would require some development to build. Comparing the 70-mm and 9 1/2-in (most common) formats, a factor of more than 3 in spot diameter is required to make the output comparable in line pairs per millimeter, neglecting the degradation imposed by optical enlargements on 70-mm formats. Current recorders do not yield this factor of 3, and LBR systems will have a better MTF for 1:10⁶-scale output film imagery.

In balance, the MTF of the EBR is adequate; in terms of MTF at 1:10⁶ scale, optical enlargement will probably contribute more degradation than the EBR.

Flexibility, the advantage of the EBR, is a catchword for freedom from being constrained to a raster scan. The EBR, as previously mentioned, can introduce geometric corrections and allows a variety of system operating configurations. This flexibility could also be obtained by sufficient computing power and storage for digital (or digitized) data. Hence, the EBR's chief advantages disappear if a digital processing system is chosen for other reasons (such as to produce a geometrically corrected digital data tape).

4.1.5 Manufacturers

The following data was obtained from RCA and CBS Laboratories. Cost data are rough estimates; firm prices cannot be obtained without in-depth discussions and a point-design specification.

A RCA

RCA is producing laser beam recorders for airborne use. These devices use 9 1/2-in film in continuous motion with a proprietary film guide. Machines have been built with a range of film speeds from about 0.01 in/s to 2 in/s. A 5- μ m spot is the smallest recommended by RCA for continuous field use. Line width is achieved by rescanning, although a 2:1 aspect ratio spot could be produced with an aperture (still require rescanning).

For direct color recording, RCA discussed a diffraction pattern technique, where a diffraction pattern of a given frequency and angle to the raster is established for each color (requiring laser beam spots at least three to five times smaller than a data picture element). A color picture can then be viewed by optically taking the Fourier transform of the diffraction pattern, spectrally filtering the proper points in the Fourier plane (defined by the diffraction frequencies and angles) and performing the inverse transform. Energy can also be supplied at the correct points in the Fourier plane so that the diffraction pattern causes the desired energy to fall on-axis when transformed. Off-axis energy is blocked, and the inverse transform yields the color image. The geometric distortions involved in such a projection system needed to produce color film products have not been addressed. Performance data published by RCA for typical black and white LBR's is given in table 18. Cost estimates range from \$80,000 to \$250,000, with no specific breakdown available at this time.

B CBS Laboratories

CBS Laboratories in Stamford, Connecticut, has produced both EBR's and LBR's.

(1) CBS LBR

CBS has produced LBR's with 5-6 μ m spots for operation at data rates of about 50-MHz, with 50% response at about 120 line pairs/mm, and has also produced a 1- μ m spot for slow drum recording. CBS has built a three-

TABLE 18
RCA LASER RECORDER CHARACTERISTICS*

	PAR 5	LASER BEAM IMAGE REPRODUCER (LBIR)	WIDEBAND SIGNAL RECORDER	LR 70 SERIES
OPTICS				
Spot Size	5 μm x 8.8 μm	12 μm	5 μm x 20 μm	5 μm
Depth of Focus (3 db)	± 0.8 mil	± 5 mil	± 1.0 mil	± 1.0 mil
Mirror Type	On-Axis Chisel point (2 faces)	On-Axis Pyramid (4 faces)	Off-Axis Polygon (dual-hex)	On-Axis Pyramid
SCANNER				
Scan Rate (scans/sec)	Variable to 2000	1250 (variable)	24 K	5 K (variable)
Scanner Speed (revs/sec)	Variable to 2000	312.5 (variable)	2000	833 (variable)
Bearing Type	Advanced Air Bearing	Advanced Air Bearing	Ball Bearing	Orifice Type Bearing
TRANSPORT				
Recording Medium	Mylar-backed film (9.5")	Mylar-backed film (9.5")	Mylar-backed film (70 mm)	Mylar-backed film (5")
Transport Speed (fps)	0.15 thru 1.0	15 thru 4	35	0.25 and up
Medium Guidance (scanning station)	Air Guide	Air Guide	Air Guide	Air Guide
Film Span (in)	24	24	12	15

* Par-5 Recording Systems Government Communications Systems,
RCA Camden, New Jersey, August 1972

color LBR for exposing 16-mm color film at TV rates; this has been operating in the field for two years.

A current estimate is \$460K for a three-color, 9 1/2-in-format LBR, with 6000 to 8000 spot diameters per line, similar to the item proposed to NASA-Houston. CBS estimates the alignment of colors to be achievable to 0.1 μm spot diameter.

A corresponding estimate for a black-and-white LBR is \$300K, depending on self-test capability and specific requirements.

(2) CBS EBR

CBS has built both framing and continuous-film-motion EBR's. The Brazilian system^{*} EBR is specified as having 50% response at 8000 lines across the format. The designers of the Brazilian system suggest a 3- μm spot which could degrade to 4 or 5 μm for field use, and would probably bid to a 1.5- μm spot system, which would require some development.

CBS is presently "tuning" a 70-mm framing EBR with an addressable field of 32K points in each of the two axes (about 2 μm between points) with a goal of a 50K \times 50K addressable field.

Cost estimates to repeat the NDPF EBR is \$385K, and \$225K for the Brazilian EBR; much of this cost is due to monitoring and self-test equipment. Small, desk-sized EBR's were estimated to cost \$65K each, in a production run of 10 machines. This machine would only hold a 20-ft film cartridge, thereby reducing the complexity and volume of the vacuum system.

4.1.6 Summary of Recommendations

In an all-digital image data processing system, the disadvantages of the LBR and the advantages of the EBR are small; an LBR is recommended.

*The Brazilian system is a hybrid electro-optical image processing system located in Brazil, South America. Initial design of this system occurred in mid-1972. It is presently in a check-out stage.

In an analog or hybrid system the advantages of the EBR make it the choice as the flexibility of the EBR allows corrections to be made in the film recording process

4.2 HIGH-DENSITY DIGITAL TAPE RECORDERS

GRC has investigated the use of magnetic tape as a medium for archival storage systems, and the various high-density recorders and systems available for such purposes. These recorders have also been considered for use by academic and corporate research facilities in establishing a standardized digital output product. The products of 30 companies were investigated.

4.2.1 Archival Storage

In performing this investigation GRC first surveyed the recording market for high-density digital equipment. We found two approaches toward the development of an archival storage system. One was the straightforward, relatively inexpensive method of using one or more independent high-density recorders with "on-line" memory limited to a single reel of tape (~100 billion bits). Another was a much more sophisticated and expensive system with an on-line capacity of about one trillion bits. A summary of data on three systems representative of these two categories is presented on table 19. The Ampex Terabit memory is the magnetic tape version of a trillion-bit memory, while the precision instrument Unicon-690-212 represents another recording medium. The IVC system is a simple digital recorder.

In order to compare the relative merits of the two approaches, the following equation was formulated to relate total processing time for a number of requests to various operational parameters.

$$T = \frac{N_R}{M} \left[P \left(T_a + \frac{I}{R_t} \right) + (1 - P) \left(\frac{T_l}{n/M} + T_a + \frac{I}{R_t} \right) \right]$$

TABLE 19
ARCHIVAL STORAGE SYSTEMS

	Small	<u>Large On-Line Systems</u>	
	IVC <u>MMR-1</u>	Ampex <u>Terabit</u>	Precision Inst. <u>Unicon</u>
On-Line Memory	7.5×10^{10} bits	10^{12} bits	10^{12} bits
Medium	Magnetic tape	Magnetic tape	Magnetic tape
Access Time	90-s average	13-s average	10 s
Transfer Rate	6.3M bits/s	4.5M bits/s	4M bits/s
Cost	\$50,000	\$1.5M	1.5M

where N_R = the number of requests to be processed
 M = number of independent recorders being used
 R_t = the data transfer rate
 T_a = time for the system to access a data item
 I = the volume of data to be transferred
 n = the number of men working
 T_1 = the time required for one man to retrieve and mount one
item of off-line data on a system (assumed to be 120 s)
 P = the probability of a requested data item being on line

Note that this equation is intended primarily to illustrate the various operational parameters and provide a gross comparison between approaches. It does not have adequate detail for a direct comparison of similar systems.

The key parameters which differentiate the two approaches are P , T_1 , and M --the probability of a data item being on line, the time required to locate and mount the data if it is not, and the number of independent machines in use. The most significant advantage of the Terabit-type system is, of course, its high on-line capacity and the resultant greater probability of requests not requiring special handling. For example, a typical MSS scene of 4 frames requires approximately 300M bits. A trillion-bit memory could therefore keep more than 3000 scenes on line available for essentially instantaneous access. Whether 3000 scenes are adequate to insure a high value for P is, of course, dependent on the randomness of the requests. It is reasonable to expect that some pattern of requests will develop in time and that 3000 scenes should be adequate to provide high on-line probabilities. In any case, fig. 15 illustrates the variation of processing time per request versus P , for the Terabit and Unicon systems. Assuming the requests are random, the value of P for the small IVC system should be some fraction K of the larger systems, where K is simply the ratio of the on-line capacity of the IVC system to

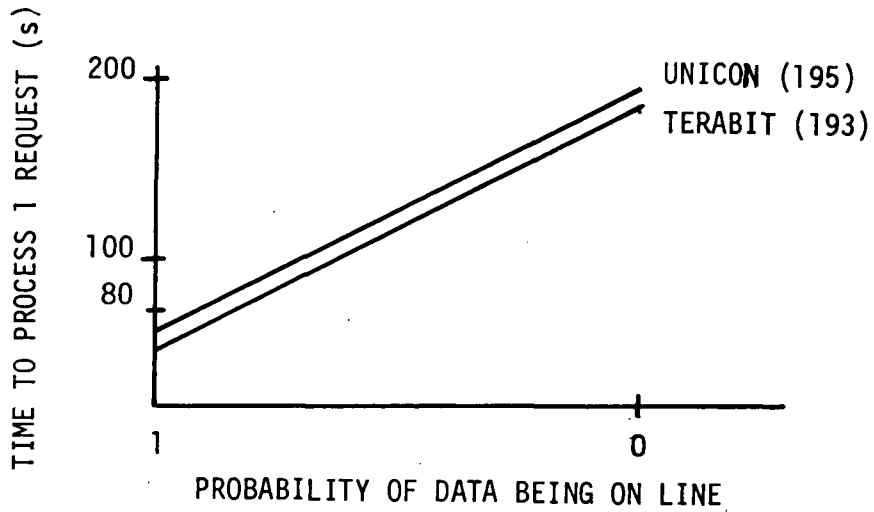

Figure 15. Processing Time vs. P, Two Systems

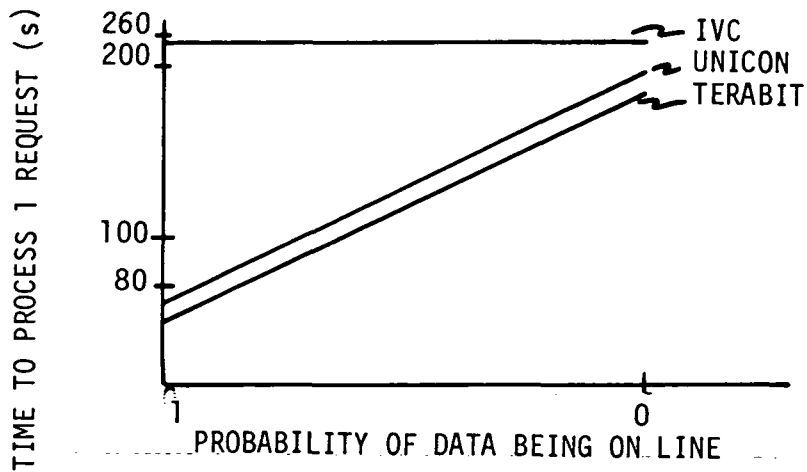

Figure 16. Processing Time vs. P, Three Systems

the larger systems. For a trillion-bit memory versus the IVC's $85 \cdot 10^9$ on-line capacity, $K \sim 1/12$. Thus, fig. 16 shows the per request processing time for the IVC system along with the Unicon and Terabit systems--assuming only one operator.

If the number of operators per machine is increased, it is reasonable to expect that the time per request to obtain off-line data will be decreased. There is, of course, a limiting value where the number of operators begin to interfere with each other. If for the moment we assume this number is 4, fig. 16 can be modified as shown in fig. 17 to indicate the range of operation for the two types of approaches.

However, the most significant advantage that the IVC-type machines have over the Terabit variety is cost. An IVC recorder costs approximately \$50,000; the Terabit and Unicon systems cost approximately \$1.5 million. Therefore it becomes feasible when comparing systems to consider multiple recorders. As fig. 18 shows, three independently operated IVC tape recorders with one operator each begin to approach the same level of operation as a single Terabit or Unicon system, but at a fraction of the price.

On this basis, we can see no immediate justification for a large, sophisticated, expensive, on-line memory (Terabit, Unicon, Mass Tape Scroller, etc., types of systems) such as those studied by Informatics for NASA. GRC recommends NASA purchase one or more (as required by the work level and throughput rate) small, high-density tape recorders. In particular GRC recommends the IVC MMR or MMR-1. The specifications on these machines are shown in sec. 4.2.3. The only significant differences are the error rate, throughput rate, and reel capacity. The MMR-1 offers a lower error rate, 1 in 10^7 , over the MMR's 1 in 10^6 . In exchange the MMR-1 has a lower throughput rate (6.3×10^6 vs. 7.1×10^6 s) and lower reel capacity (7.5×10^{10} bits vs. 8.5×10^{10} bits). Both devices sell for approximately \$50,000 each.

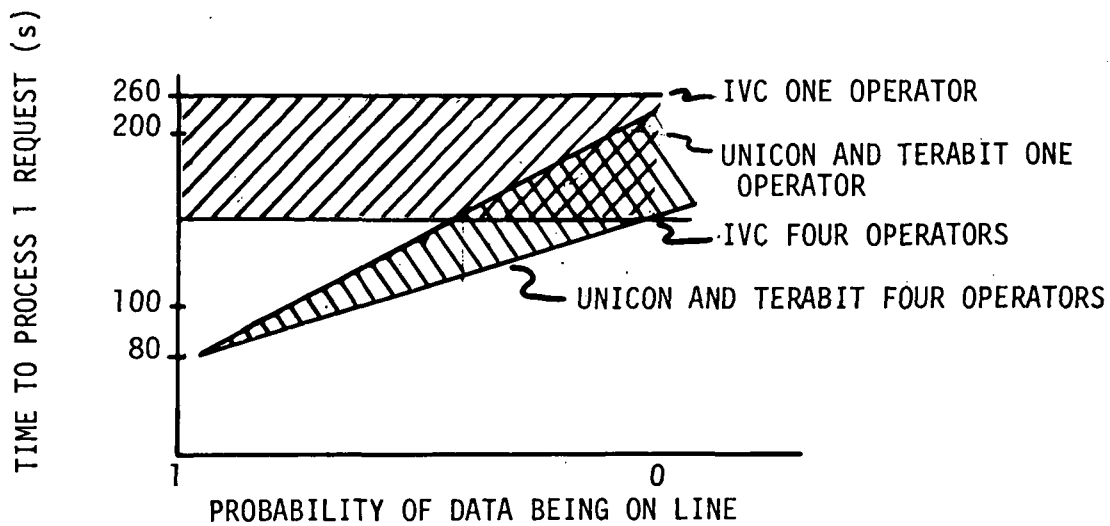

Figure 17. Effect of Using One and Four Operators

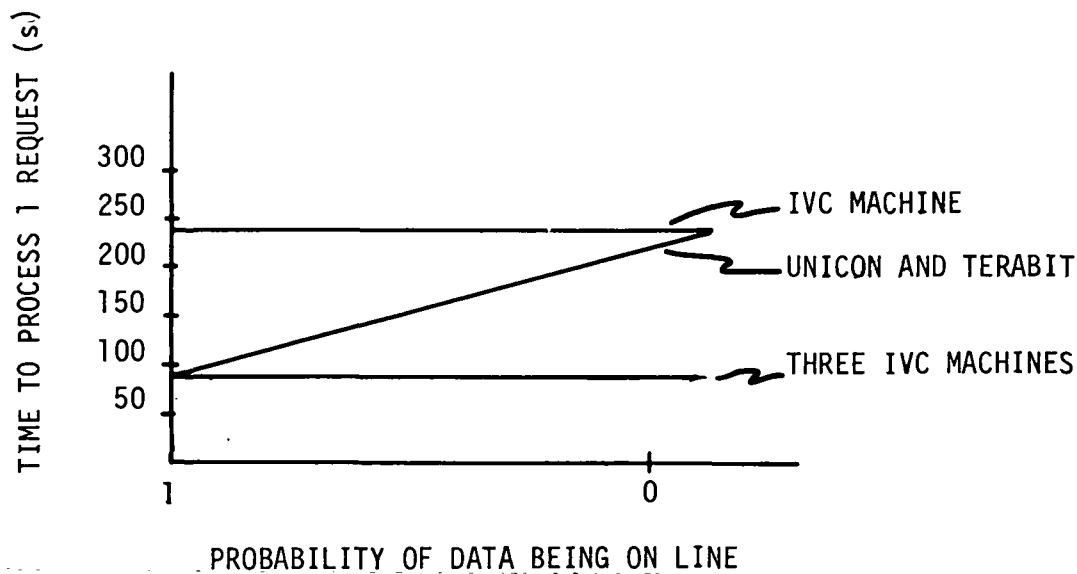

Figure 18. Effect of Multiple Recorders

It is our opinion that the IVC has the best of a limited selection of recorders. Of more than 30 companies contacted in our survey, only the four reported in sec. 4.2.3 produced any type of high-density digital equipment. The IVC offers the advantage of being a commercially available and proven recorder with no development required. It offers a higher packing density at lower cost than can be obtained from the Leach equipment, and the Echo Science recorder is as yet not in production. The RCA recorder (TR-70) offers approximately half the density per inch or one-quarter the total area packing density at comparable error rates, but with higher input/output data rates (15M bits/s and the ability to output data at half to one quarter the input rate. However the cost (\$150,000) is approximately 3 times that of the IVC machine, which makes it infeasible for use by smaller investigators.

4.2.2 Digital Products

GRC has also investigated recorders for purchase by the various ERS users so as to have a standardized digital output product. One of the prime problems here has been the lack of information on user data processing facilities. For example, IVC plans to introduce in 1974 a cartridge high-density recorder fully compatible with the MMR and MMR-1 and selling for approximately \$15,000. With packing densities and throughput rates identical to those of the larger machines, and with a cartridge capacity of approximately 2.5×10^{10} bits (or approximately 300 MSS frames) it would represent an ideal recorder for the users to purchase and for NASA to use in making digital products. However, the 6M bit/s throughput rate might be too high for use in the data processing facilities of some smaller users, and none of the IVC machines has the capability of speed reduction.

Thus our recommendation here is the use of two recorders to generate digital products. If the IVC cartridge recorder is available in 1974 it represents the most convenient, lowest cost recorder for use by ERTS investigators. The only problem is high data rate, which may be beyond the

capabilities of some users. As an alternative we suggest the Leach HD-103 serial-to-parallel converters. This can be used with any high-quality instrument recorder with a 2-MHz bandwidth. If a single 7-channel HD-103 is used to record 12 channel (6 at a time) on a standard 14-track instrumental recorder, this will yield approximately 250K bits in packing density or approximately 1 frame per 30 in of tape. Use of the HD-103 would allow the reduction of output rate in proportion to the speed-reduction capabilities of the recorder (i.e., if the recorder allows a 10^{-1} speed reduction, throughput rate can be reduced from 6.3 to 0.63M bits/s). Since most small users probably possess a high-quality instrument recorder, this alternative represents a relatively modest investment.

4.2.3 Device Description

COMPANY: LEACH
MODEL: HD-102

GENERAL DESCRIPTION

The Leach Model HD-102 Digital Signal Conditioner is a 2-channel signal processor that accepts a serial NRZ-C digital pulse train, accompanied by a synchronous clock, at each channel input and converts each input to a preconditioned unique code which may be recorded on a standard IRIG specified wideband direct recorder. When the recorded signal is reproduced through the demodulation and clock recovery portion of the HD-102, the original input signal is recovered. A synchronous clock is also provided on a separate output line for each channel.

Self-contained error checking circuits include a word generator and bit comparator logic to verify performance integrity within seconds.

PERFORMANCE SPECIFICATIONS

- Number of Channels: 2
- Selectable Input Data Rates: 1024 and 128K bits/s $\pm 2.5\%$ are standard. Any two rates for each channel may be selected on special order.
- Selectable Output Data Rates: Specify two, proportional to input rates, depending upon reproduce/record speed ratio.
- Input/Output Data Format: NRC-C
4.5 \pm 1 volt = Logic 1
0 \pm 0.5 volts = Logic 0
- Packing Density: Maximum 16 K bits/track/inch when used with a recorder meeting the following performance criteria.

- Digital Error Rate: Less than 1 missed bit in 10^6 when used with a recorder meeting the following performance criteria.
- Missed Bit Display: 1 light to indicate 10 errors.
1 light to indicate 100 or more cumulative errors. Switchable to indicate number of 100 ms error bursts.

DIRECT RECORD/REPRODUCE CHANNEL PERFORMANCE CRITERIA

- Normal Input/Output Level: 2 volts peak-to-peak
- Input Impedance: 75-300 ohms
- Output Impedance: 75-300 ohms
- Bandwidth: Flat within ± 3 dB from 800 Hz to 1 MHz for 1.024 M bits
- Instantaneous S/N Ratio: 20 dB rms/rms minimum from 800 to 1 MHz for 1.024 M bits
- Tape Speed: That required to yield above bandwidth and S/N performance
- Tape Speed Stability: Less than $\pm 1\%$ variation from nominal throughout the record/reproduce cycle
- Envelope Delay: Less than ± 0.6 μ sec over the bandwidth of interest
- Distortion: Total harmonic distortion 4% when signal is recorded at nominal 3% third harmonic distortion
- Flutter 1% peak-to-peak

ELECTRICAL AND MECHANICAL SPECIFICATIONS

- Size: 5 1/4" × 11 1/4" × 19" nominal.
(Mounts in standard RETMA rack.)
- Weight: 20 pounds
- Power: 117 V, 1 Ø, 60 Hz, 50 watts

OPERATIONAL BACKGROUND

The following examples describe hardware to which HDDR technique has actually been applied for evaluation or product improvement. The densities, data rates, and results for each example are contained therein.

MTR-9100 MASS MEMORY TAPE UNIT - 8000 BITS/INCH

This cassette-loaded tape unit features HDDR on sixteen tracks of 1/2 inch tape in an ideal balance between storage capacity, access time, and cost. Capacity is nearly 400×10^6 bits/cassette with an average access time of less than 5.5 s. The unit reads serial in and out on any one of the sixteen tracks. Its companion control unit provides for selecting one of two tape units and converts all data to byte parallel format to yield a transfer rate of 133,000 9-bit byte/s.

Each of the two tape units is designed to accept the cassetts delivered by an automatic loader so that several cassettes can be on line to both tape units at any given time.

MTR-7100 HDDR

The HDDR/MTR-7100 is an adaptation of a wideband IRIG standard analog recorder to a high data yield digital application.

Systems of this configuration delivered to date typically record 16.7 kbits/inch on each of fourteen tracks. The MTR-7100 tape capacity is 9200 feet and the tape speeds range from 3 3/4 ips to 120 ips.

Utilizing all fourteen tracks for HDDR carriers, the data capacity of the HDDR/MTR-7100 exceeds 25×10^9 bits. Operating at 120 ips, the combined output from all tracks exceeds 27×10^6 bits/s. Error rate is typically better than 1×10^{-6} .

In this NASA application, the density has been conversely set at approximately 4000 bits/inch for operation at 7 1/2 and 15 ips.

LEACH MTR-2000 SATELLITE - 10,000 Bits/Inch

One channel of HDDR electronics and one deskewing buffer was added to this system which originally had only analog capability of 10,000 cycles/inch. We now demonstrate 256,000 bits/s at 25 ips for a density slightly in excess of 10,000 bits/inch. The same tape has been in use twenty months. 10^7 error-free bits are demonstrated by recording on sections of the tape chosen at random for nearly every potential customer. Performance is extremely reliable.

MTR-3200 - 6000 Bits/Inch

Standard HDDR electronics for the MTR-3200 transports are available. Several of these instruments have been shipped. A typical system contains two channels of HDDR operating at 90,000 bits/s. The resultant density of 6000 bits/inch at a speed of 15 ips exhibits error rates in the

order of 1 missed bit in 10 million. Although playback electronics are available for this instrument, data reduction is more typically accomplished with the HD-102 used in conjunction with a high-quality analog tape reproducer. Many customers who have purchased MTR-3200's also own Ampex FR-1600 or Hewlett-Packard 3950 tape reproducers, which are directly compatible with HD-102.

SONY TC-100 - 3000 Bits/Inch

A standard Sony portable recorder, Model TC-100, is routinely used to record HDDR carriers on conventional audio tape (\$1.25/cartridge) at a density of approximately 3000 bits/inch. Over 9 million bits have been recorded on a full cartridge without missing a bit. This unit is frequently used to demonstrate the interchangeability between one tape unit and another. The carrier is recovered from the headphone monitor output and applied to the HDDR decoder circuits for reconstruction into digital format.

POTTER SC-1080 - 8900 Bytes/Inch

This demonstration unit was constructed to prove the feasibility of on-line operation of HDDR tape equipment with high-speed computers. A byte consists of nine bits recorded in parallel on nine tracks. The Potter SC-1080 was a conventional computer-compatible tape handler designed for 800 bytes/inch operation. At 8900 bytes/inch operation (using HDDR), the transfer rate of data was raised from 90,000 bytes/s to one million bytes/s. The error rate, when measured by the computer program, was approximately 1.5 errors in each billion bytes. This compares to approximately 22 errors in each billion bytes realized when testing the IBM tape unit assigned to the computer.

- Cost: Approximately 16K for two channels
- Comments - Pro
 - Can be interfaced with a variety of recorders (including Ampex model line 1900).
 - Maximum packing density with 14 channel Ampex recorder (using 12 data tracks) 192 KBPI
 - Read at one data rate--output at others
 - Proven reliability
- Comments - Con
 - Limited to 2 channels at a time

COMPANY: LEACH
MODEL: HD-103 - HIGH DENSITY DIGITAL DATA CONVERTER

GENERAL DESCRIPTION

The Leach Model HD-103 Magnetic Tape Digital Data Converter is a self-contained unit that allows simultaneous record and playback of up to 42 channels of PCM data, 7 per unit, on a wideband instrumentation quality recorder, using the Leach HDDR-II encoding and decoding technique. HDDR-II is a member of the double-density family of codes and permits tape densities of 17 KBPI to 33 KBPI (depending on transport quality).

Internal electronics consist of one clock and housekeeping board and up to seven plug channel modules per 5" rack.

Each channel can insert an unambiguous (not found in data) sync code word of 8 bits into every 128 bits of data to be recorded. Whether or not to include sync is an option of the user by means of a front panel switch.

All modules recorded at the same bit rate in synchronism with one another (phase locked to a common clock). Playback may be either synchronous or asynchronous but all modules must playback at the same rate (within a few percent).

All required deskewing electronics are included

PERFORMANCE

- Number of Channels: 7 per unit; 42 maximum
- Input Rate: Variable (approximately 100 to 1) to maximum of 3 M bits/s/channel or 21 megabits/unit (dependent on the quality of the transport in use).
- Output Rate: Variable (100 - 1) to maximum of 3 M bits/s/channel

- Packing Density: Maximum 33 K bits/inch (dependent on quality of transport)
- Error Rate: 1 in 10⁶
- Transport Requirements are the same as for the HD-102. However,
- for the same transport parameters the HD-103 will yield twice the packing density of the 102.

OPERATIONAL BACKGROUND

One unit in operation at NASA, Huntsville, 14 channels, 12 data channels used with Leach recorder 16 K bits/inch.

One unit to be shipped to General Electric in June; 25K bit/inch.

- Cost: 16 K for 7 channels
- Comments - Pro
 - Higher packing density lower cost than HD-102 (360 KBP at 2K per channel vs 8K per channel)
 - Read-write at different rates
- Comments - Con
 - Only one unit in operation.

COMPANY: INTERNATIONAL VIDEO CORPORATION

MODEL: MMR-1

DESCRIPTION

Off the shelf--high density mass memory recorder. Self contained

SPECIFICATIONS

Signal Electronics Data (Rotating Head)

- Input/Output Data Rate 8.1×10^6 bits/s
- Packing Density 1×10^6 bits/inch²
- Throughput 6.3×10^6 bits/s
- Error Rate <1 in 10^7 bits (uncorrected)
- Input Data Format Serial NRZ plus clock
- Output Data Format Serial NRZ plus clock
- Addressable Record 105K bits
- Capacity on 7000' Reel 7.5×10^{10} bits

Control and Address (Fixed Heads)

- Input Rate 2.4K bits/s/per track
- Output Rate 2.4K bits/s-139K bits/s (search)
- Error Rate <1 bit in 10^7 (uncorrected)
- Format NRZ;, 347 bits/inch
- Address Word
 - Permanent Address 30 bits
 - Status Address (updated) 30 bits

Tape Transport

- Record 6.91 ips linear--(723 ips scan head-to-tape speed)

(MMR-1)

- Playback 6.91 ips linear--(723 ips scan head-to-tape speed)
- Search 400 ips--bidirectional. Average access time to any record is <90 s
- Start 300 ms from standby to capstan lock
- Wind/Rewind 400 ips (rewinds 7000' reel in <3.5 min.)
- Start/Stop Time @ 400ips 5.0 s max
- Rewind Time 3.5 min for 7000'
- Reel Size Up to 12 1/2" in cartridge
- Cartridge Loading Self-threading is standard
- Heads
 - A. Helical scanner contains read/write, write verification and erase head.
 - B. Four longitudinal tracks are provided: control, address, address clock, and address status
- Tape 1" 3M video tape
- Local Controls Push buttons for fast reverse, read/write speed, unload, fast forward, read, stop, write.

Physical Characteristics

- Weight 400 lbs
- Size 37" high × 37" wide × 21" deep
- Power Required 115V ±10%, 60 Hz ±1/2 Hz single phase
20 amp (50 Hz optional)

OPERATIONAL BACKGROUND

Several in use. Four units purchased and operating by Pen Colonial Life Insurance Company where interchangeability of tapes a vital requirement. Cost 50K per unit.

- Comments - Pro
 - Demonstrated operation and reliability
 - High packing density-- 10^6 bits/inch
- Comments - Con
 - Only one input output rate which may be too high for some users.

COMPANY: INTERNATIONAL VIDEO CORPORATION
MODEL: MMR

DESCRIPTION

Off the shelf--high density mass memory recorder. Self contained.

SPECIFICATIONS

Signal Electronics Data (Rotating Head)

- Input/Output 8.1×10^6 bits/s
- Packing Density 1×10^6 bits/inch²
- Throughput 7×10^6 bits/s
- Error Rate <1 in 10^6 bits (uncorrected)
- Input Data Format Serial NRZ plus clock
- Output Data Format Serial NRZ plus clock
- Addressable Record 119 bits
- Capacity on 7000' Reel 8.5×10^{10} bits

Control and Address (Fixed Heads)

- Input Rate 1.8K bits/s/per track
- Output Rate 1.8K bits/s-82 bits/s (search)
- Error Rate <1 bit in 10^6 (uncorrected)
- Format NRZ1, 260 bits/inch
- Address Word
 - Permanent Address 24 bits
 - Status Address (updated) 24 bits

Tape Transport

- Record 6.91 ips linear--(723 ips scan head-to tape speed)

(MMR)

- Playback 6.91 ips linear--(723 ips scan head-to-tape speed)
- Search 400 ips--bidirectional. Average access time to any record is <90 s
- Start 300 ms from standby to capstan lock
- Wind/Rewind 400 ips (rewinds 7000' reel in <3.5 min)
- Start/Stop Time @ 400ips 5.0 s max.
- Rewind Time 3.5 min for 7000'
- Cartridge Loading Self-threading is standard
- Heads:
 - A. Helical scanner contains read/write, write verification and erase head.
 - B. Four longitudinal tracks are provided: control, address, address clock, and address status.
- Tape 1" 3M video tape
- Local Controls Push button for fast reverse, read/write speed, unload, fast forward, read, stop, write.

Physical Characteristics

- Weight 400 lbs
- Size 37" high × 37" wide × 21" deep
- Power Required 115V ±10%, 60Hz ±1/2Hz single phase
20 amp (50 Hz optional)

OPERATIONAL BACKGROUND

Several in use. Four units purchased and operating by Pen Colonial Life Insurance Company where interchangeability of tapes a vital requirement. Cost 50K per unit.

- Comments - Pro

- Demonstrated operation and reliability
- High packing density-- 10^6 bits/inch

- Comments - Con

- Only one input output rate which may be too high for some users

COMPANY: ECHO SCIENCE
MODEL: ENCODER/DECODER 205a - 205b

DESCRIPTION

Includes NRD data stream to high density format - one channel only. No serial to parallel conversion.

- Specifications: Max packing density - 20KBPI
- Operational Background: No units sold
- Cost: 15 K per channel
- Comments:
 - No serial to parallel conversion
 - No deskewing electronics
 - Limited to one channel

COMPANY: ECHO SCIENCE
MODEL: ESC-411D--DIGITAL RECORDER

DESCRIPTION

Video recorder modified for digital

SPECIFICATIONS

General Characteristics

- Size 28" × 19" × 16 1/2" transportable, portable or rack mounted
- Weight Less than 140 lb
- Input Power 105-125 or 210-250 VAC, 48 to 440 Hz single phase
- Power Consumption 150 watts nominal, 500 watts surge

Tape Transport

- Reel Size NAB 8", 10 1/2", or 12 1/2" with cover removed
- Tape Speed 3 3/4 in./s. standard. Other speeds optional
- Recording Medium 1" video tape, 1 mil polyester-backed, longitudinally-oriented gamma ferric-oxide, B wrap only
- Recording Format Twin head Echo Science format with 12° 40' scan angle
- Video Scanning Speed 315 in./s writing speed, other speeds optional
- Record Time Six hours with 12 2/3" reel (1.13 Mil tape) at 3-3/4-in./s
- Start Time Capstan and head drum servo in sync in < 3 s

- Stop Time 3 s
- Loss of Power In the event of loss of power the transport stops with no stretching or slippage of tape.

Digital Performance

- Transfer Rate 1.5M bits/s to 15M bits/s
- Bit Error Rate 1 error in 10^6 bits
- Bit Jitter The timing stability of the output data will be determined by the accuracy of the internal frequency standard.
- Data Input/Output Impedance: 75 ohms resistive
Level: 1 volt p-p single ended
- Clock Input/Output Impedance: 75 ohms resistive
Level: 1 volt p-p single ended

Auxiliary Channels

- Number Two
- Inputs Microphone: -55dBm, 150 ohms, balanced
Line: -10 to +4 dBm, 600 ohms balanced or unbalanced
- Outputs +8 dBm, 600 ohms, unbalanced
- Audio Frequency Response 60 Hz to 12 kHz, ± 3 dB.
- Audio Signal-to-Noise Ratio 45 dB peak-to-peak to rms noise measured at 1 kHz at normal level
- Audio Internal Channel signal-to-noise ratio.

- Operational Background: No units sold as yet.
- Cost: Approximately 50K per unit.
- Comments: Transfer rate can be adjusted at factory for value between 1.5 and 15M bits/s, but is not variable in field. Also read rate and output rate must be the same.

COMPANY: RCA
MODEL: TR-70

GENERAL DESCRIPTION

Rotating head video recorder converted to digital use.

PERFORMANCE SPECIFICATIONS

- Packing Density: 400 K bits/in² or 800 K bits/in²
- Error Rate: 1 in 10⁷ with 400 K packing density
1 in 10⁶ with 800 K packing density
- Input Rate: 15 megabits/s
- Output Rate: 15, 7-1/2, 3-3/4 megabits/s
- Tape Size: 2 in standard videotape
- Cost: \$150,000
- Number of Units in Use: 13

COMPANY: RCA
MODEL: TCR-100

GENERAL DESCRIPTION

Cartridge recorder with the same performance specifications as TR-70, only uses 300 ft video cartridges.

- System Cost: \$175,000 to \$300,000
- Number of Units in Use: No digital units yet in use, 200 video units in field.

5 DATA LOADING STUDY

5.1 INTRODUCTION

As a relatively separate task, simulations were run for various ERS configurations. These runs generated data used to determine the load into the DPF as well as data for use in sizing operational and command parameters.

This section is subdivided as follows:

- Sec. 5.2 Summary - The loading to the DPF as determined from the simulation runs is presented.
- Sec. 5.3 Simulation - The simulation system is briefly described. Constraints and limitations are presented.
- Sec. 5.4 Weather Forecast Simulation - The method used to generate simulated NOAA cloud cover forecasts is described.
- Sec. 5.5 System Constraints - The effects of the system constraints on the loading study is deduced from the output and summarized.
- Sec. 5.6 Geographical Effects - The effect that the geographical distribution of targets has on the loading study is described.
- Sec. 5.7 Fifth-Band MSS Night Operations - Five additional runs were produced to identify night targets. The results of these runs are presented.

The computer output from the loading simulation runs is presented in Appendix A; the output from the night runs is presented in Appendix B. Both appendixes are contained in a separate volume; descriptions of the listings are included.

5.2 SUMMARY

A simulation was run for each of the following receiving sites:

Sioux Falls

Sioux Falls and Alaska

Sioux Falls, Alaska, and Guam

For each case, a run was made before and after simulated cloud cover weather forecasts were used to remove cloud cover degraded targets* from the data base. All runs were made with targets on successive orbits within 30° of the poles eliminated for overlap considerations, and frames with sun elevation angles less than 10° (at either equinox) eliminated.

Four data items for each run are significant. They are:

1. Frames scheduled, no weather
2. As No. 1 above, plus 2 frames overhead per record operation
3. As No. 1 above, using simulated weather forecast
4. As No. 3 above, plus 2 frames overhead per record operation

Using data from these runs, estimates (two significant digits) were made of the actual, nonredundant number of frames to be expected as an average in each configuration. However, an overhead is incurred for each separate record operation and for each separate playback operation. An estimate of the number of record operations can be made from the simulation data. An equivalent of 50-s operation (2 frames) was assessed for each record operation. Estimates for playback overhead were added, based on the number of playback operations expected. These overhead estimates were added to the actual data to obtain the estimated average load to the DPF. This load to the DPF represents input (without reruns); the actual data estimate can be used to size production and output (after cloud cover data is removed.) A specific DPF design may be able to edit out the

* In this section, the term target is used synonymously with scene and implies that a preplanned command sequence is necessary to "target" a given scene.

overhead data while another design's throughput may be a direct function of the total input loading.

Table 20 presents the loading estimates as a concise summary; fig. 19 presents the estimates and the simulation results in a graphical format. Also shown is the effect of using simulated weather forecasts on the simulation.

Simulating weather forecasts breaks available target strings into small pieces, forcing the number of recording operations and the number of recorded unrequested frames to increase. Targets are also deleted within station cones, allowing more downlink time, and then, since there are sufficient targets even after weather forecasts are applied, restricts the decrease in loading.

TABLE 20
ESTIMATES, FRAMES/DAY, AVERAGE

	<u>1 Station</u>	<u>2 Stations</u>	<u>3 Stations</u>
<u>Load to DPF</u> (includes overhead frames for recorder start and stop for data acquisition and playback)	150	260	350
<u>Actual Data</u> (nonredundant data)	120	200	260

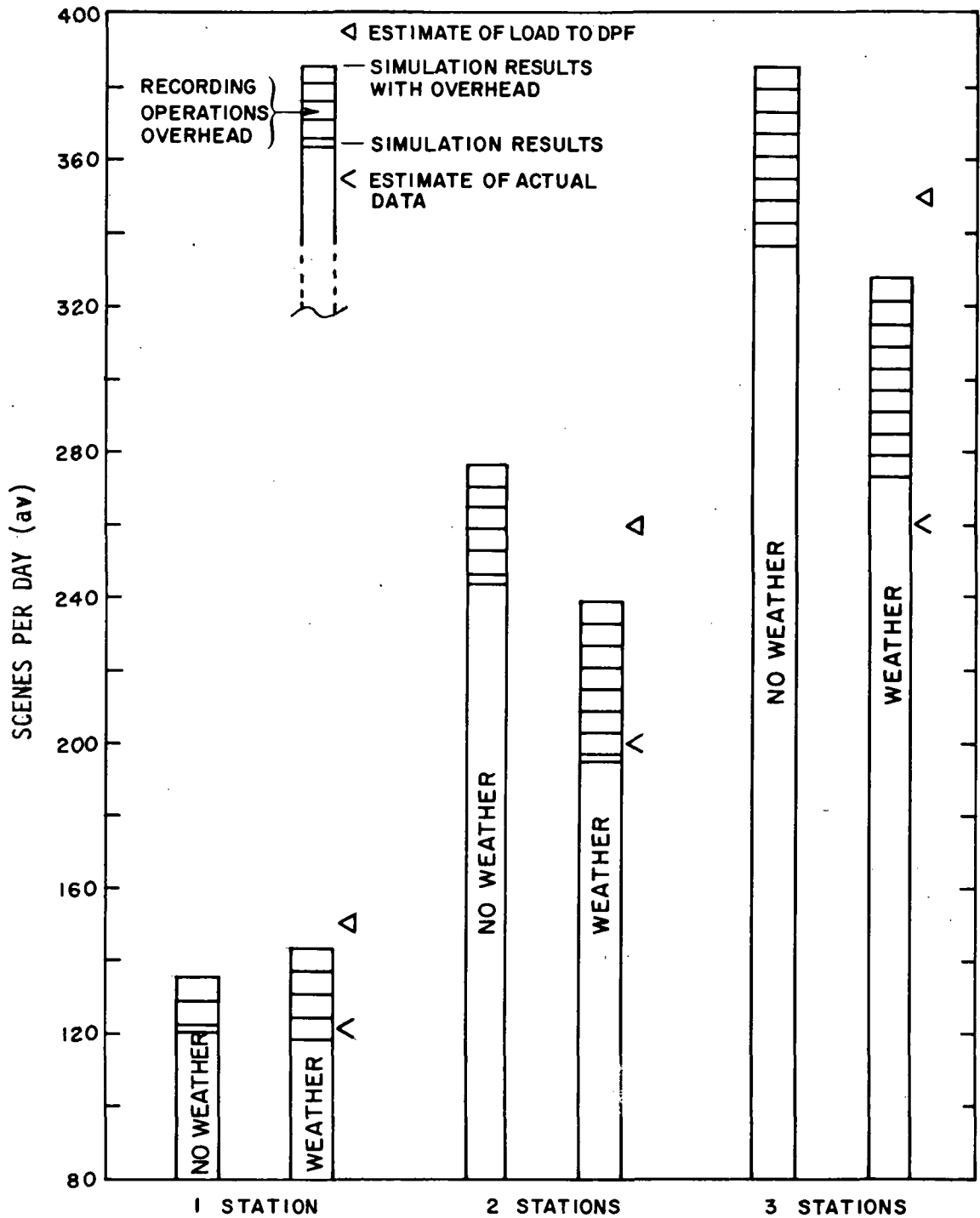

Figure 19. Simulation Results

Table 21 presents the results of the simulation in more detail.

The table contains:

Requested, Recorded	- Actual data frames requested by users and "taken" by the simulation
Real Time	- Data frames requested by users within any station cone
Unrequested, Recorded	- Frames taken of areas not requested by any user. Occurs where there is not enough time between operations to turn the sensors off, then on again
Total	- Sum of above three items
Average/Day	- The total divided by the 18 days of one coverage cycle. Plotted in fig. 19 as "Simulation Results."
No. Operations	- The number of record operations performed in the simulation.
Average/Day with Overhead of 2 Frames/Operation	- The "total" from above plus 2 frames per operation (above) divided by 18. Plotted in fig. 19 as "Simulation Results with Overhead." This is record overhead only; playback overhead has not been assessed here.

TABLE 21
SIMULATION DETAIL

	DATA FRAMES								
	1 STATION			2 STATIONS			3 STATIONS		
	No Weather	Weather		No Weather	Weather		No Weather	Weather	
Requested, Recorded	980	1050		2479	1986		3784	3120	
Real Time	1143	1030		1843	1427		2166	1583	
Unrequested, Recorded	26	39		47	102		104	208	
Total	2149	2119		4369	3515		6054	4911	
Avg/Day	119	118		243	195		336	273	
No. Operations	141	230		298	380		435	486	
Avg/Day with Over- head of 2 Frames/ Operation	135	143		276	238		385	327	

5.3 SIMULATION

The simulation used for this loading study was designed to model the constraints of the ERTS-1 system,* apply values to user requests for recorder-collected data, and optimally schedule the model. The purpose of this simulation system originally was to evaluate value assignment algorithms to prioritize user requests.

Some changes have been made to the system, a cloud forecast simulation has been added, and the simulation is executed in a new mode to perform the loading study.

The user request that drives this study is the ERTS-1 data base for the first quarter for non-U.S. requests. A single artificial user has been created and added to the data base to request the U.S. data. This data base is representative of the world land masses, and to avoid biasing the study by using specific priorities for the users, the priorities (frame values) used in this study are generated by a computer pseudo-random number algorithm.

The simulation was run for three basic cases, differing in the number of ground receiving stations. The runs consider:

1. Sioux Falls
2. Sioux Falls and Alaska
3. Sioux Falls, Alaska, and Guam

The constraints observed in these simulations are:

1. No limit on total daily take. The simulated take is the prime study output.
2. No limit on number of operations, since the new COMSTOR will be available.

* E. P. McMahon et al., Earth Resources Technology Satellite Mission Simulation, General Research Corporation CR-1-320, September 1972.

3. A 65-frame tape recorder. A 30-min tape recorder can hold 72 frames, but a 10% overhead for starting and stopping has been deducted. Starting and stopping costs are not modeled in the scheduling algorithm.
4. When the sensor is turned off, it cannot be turned on for 200 s (8 frames).
5. As 3° elevation or optical station cones are used, two frames are used for AOS (acquisition of signal) and LOS (loss of signal) observation. No tape dumping is allowed in these 100 s.
6. Fifty seconds per station contact is charged as overhead for downlinking data before and after desired data as a precaution against tape position uncertainties and to provide data for synchronization before "good" data is received. This is called freewheeling in the printouts.
7. The minimum downlink allowed (including the 50 s in item 6 above) is 8 frames in day contacts, 9 at night. The difference is in roundoff. The day constraint was rounded down as real time targets will usually be present, limiting downlink yet providing sensor data.
8. Sun angle, overlap, and weather forecast constraints are applied to the data base.

Certain precautions must be observed in interpreting these simulation runs.

1. For true optimization, the tape recorder must be empty at the end of each day. This does not always occur, but the result should be near optimum.
2. Total score, not total frames, is maximized. We assume an operational system will have the same objective.

3. Frame scores are not sufficiently diverse (they are 2 to 9 instead of, say, 200 to 900) for a number of reasons: constrained ultimately by the number of different users; increases simulation running time; difficult to present results; etc. This results in a "granularity" in the data base which cannot be resolved by the simulation algorithm. For example, if, at a point in a simulation, 10 frames can be put on the tape recorder and there are 20 frames of value 9, the algorithm will not choose any. If these 20 frames were 10 of value 93 and 10 of value 92, the 10 of value 93 would be selected. The results are thus somewhat conservative.
4. The results are somewhat sensitive to the point chosen to start the simulation. This sensitivity is worse if the down-link capability is restricted.
5. The simulations are single samples of a random process.

5.4 WEATHER FORECAST SIMULATION

The NOAA weather forecasts are simulated using statistics taken from actual NOAA forecasts. The forecasts, and not the actual weather were simulated since the forecasts are used to prepare the spacecraft and determine the data load. (The accuracy of the forecast determines the percent usable data received.)

The framed world was divided into five zones:

<u>ZONE</u>	<u>FRAMES</u>	<u>LATITUDE (FRAME CENTER)</u>
1	1 to 14	80.5N to 66.5N
2	15 to 44	65.2N to 24.4N
3	45 to 77	22.9N to 22.9S
4	78 to 107	24.4S to 65.2S
5	108 to 121	66.5S to 80.5S

A forecast for an orbit is characterized by cloud category and latitude bands. Using NOAA data, simple frequency estimates of probabilities were made for:

- Unconditional probability of forecast category (1, 2, or 3)
- "Length" of a forecast of each category (1 to 15 frames)
- Conditional probability of forecast category given preceding forecast.

These probabilities were calculated for each region.

Successive temporal orbits were considered as having uncorrelated forecasts, rationalized by distance between the orbits. Adjacent orbits were considered as having uncorrelated forecasts, rationalized by time between orbits (one day) and the westerly progression (weather persists eastwards, generally in the northern hemisphere, where most targets appear).

A simulated forecast is then made by the following algorithm. The term "generate" is used to mean "select an outcome on the basis of a pseudo-random number calculated by the computer and a probability table." (For example, if x is in the pseudo-random number, say "heads" occurred if $0 \leq x < 0.5$ and "tails" if $0.5 \leq x \leq 1$.)

1. Generate a forecast F for frame 1 from unconditional statistics for zone 1.
2. Generate a length L from statistics on forecast F in zone 1.
3. Next frame $N = L + 1$.
4. $Z =$ zone of frame N .
5. Generate forecast F' for frame N based on conditional statistics for preceding forecast F and zone Z .
6. Generate a length L from statistics on forecast F in zone Z .

7. $N = N + L, F = F'$.
8. If not finished, go to step 4.

The forecasts generated by the algorithm check reasonably well against the NOAA statistics. They were not generated from a sufficiently large number of samples to withstand stringent statistical tests, but the simulation is sufficient for the purpose of this study. (The undesirable alternative is to use some past NOAA prediction, allowing no flexibility.)

5.5 SYSTEM CONSTRAINTS

The system as modeled is constrained by the following:

1. Location of targets
2. Location and duration of station contacts
3. Number of "on-off" operations allowed between stations
4. Minimum "off" time between operations
5. Maximum allowed frames per day
6. Capacity of tape recorder

The simulations show that the third constraint, the number of operations governed by the size of the command memory is, in fact, not an operative constraint if the 512-position memory is used. The maximum number of "on-off" sequences used between station contacts was 12 for the single-station Sioux Falls case, 11 for the two-station Sioux Falls, Alaska case, and 7 when Guam is added to the two-station case. Command memory, then, is not limiting.

In the simulation runs, no constraint was placed on the number of frames per day, and the target base used was fixed on the ERTS-1 data base. The minimum number of "off" frames allowed between operations was taken as 8 (200 s) and resulted in taking an average of 5 unrequested frames per day in the two-station simulation.

The true remaining constraints are the tape recorder length and the length and duration of station contacts.

In the two-station simulation, station contact was available to downlink 3266 frames. However, only 2088 frames were taken off the recorder. The unused contact time resulted from one of the following reasons:

1. Insufficient targets at the right location (or station contact time at the wrong location).
2. Insufficient tape recorder capacity.
3. Unresolvable target conflict.

Item 1 cannot be removed by changing station locations, since it is the inherent width of the station that is the problem. That is, the first few contacts with a station are fully utilized, the last contacts of a day are not. Of course, more data can be recovered if more stations are added, but only the "eastern 2/3" of any station is fully utilized (constrained, of course, by real-time target location and distribution).

A larger capacity tape recorder would increase station contact utilization by carrying data to the western third of the stations. This would directly increase the amount of recoverable data.

The third reason given for underutilization is responsible for a loss of about 20 frames on 6 of the 18 days. This results from the granularity of the target value system. For instance, if 20 targets could be recorded, but 25 equal-value targets are available, no mechanism is available to choose 20 of the 25 targets, so none are chosen. This is a minor point, easily solved in an operational system by having values go from, say, 1 to 90 instead of from 1 to 9.

5.6 GEOGRAPHICAL EFFECTS

The simulation runs demonstrate the system preference for certain geographical areas. To observe this, it is necessary to understand some of the workings of the simulation.

For each day's simulation, one day's worth of targets (usually 14 revolutions) are identified for the optimization routine. Targets have already been removed for "overlap," sun angle, and weather forecasts. This day's worth of targets is broken into a number of passes, where a pass is defined as the period from any station LOS to the next AOD. On any pass, the tape recorder is not allowed to be overloaded, and the recorder is dumped (if possible) at the end of a pass. The optimization routine attempts to schedule all positive-value targets, and determines the tape recorder status. If overloaded, the pass on which the overload occurs is identified, and a Lagrange multiplier is subtracted from every frame in the day. Thus, frames not requested and targets with low value will then have a negative return. Scheduling is attempted again up to and including the identified pass, and the Lagrange multiplier value is iterated until a schedule can be achieved which does not overload the recorder on the critical, identified pass. The remainder of the day is then scheduled with another value of the Lagrange multiplier.

Consider, for an example, a typical day which starts with a nighttime Sioux Falls LOS. In attempting to schedule all targets, the recorder fills up no later than South America if this day is a day on which "overlap targets"--targets above 60°N and below 60°S --are eliminated. The Lagrange multiplier L_1 is iteratively raised to 6 or 7, leaving only targets with original value 7, 8, and 9 for scheduling (some lower value targets may be taken and some high value ones ignored to satisfy other constraints, but that is not germane to this example). A schedule is selected with L_1 equal to 6 or 7, and targets are chosen to give an optimal schedule for the first half of the day. Note that targets in Africa, Europe, South America, and the Middle East are considered relative

to one another--a value 8 target in South America will probably be scheduled if value 8 targets are scheduled in Africa. The optimization routine considers all passes up to the overloading pass at one time. Then, because of target and station distribution, no scheduling problems are encountered for the rest of the day, and the Lagrange multiplier is set to zero. Thus, all targets are scheduled over the second half of the day. (When targets are not eliminated for overlap, 12 or 13 of the 14 revs are scheduled at $L1 = 6$ or 7 and the last rev or two are scheduled at $L1 = 0$.)

The point of the example is this: the world areas are naturally segmented into regions by the placement of ground stations. Within each region, values assigned to targets (priorities) do, in fact, rank the targets for scheduling. High-priority targets anywhere in the region will probably (subject to other constraints) be scheduled before lower priority targets. However, targets in different regions are not scheduled equally by priority. A low priority target in Southeast Asia is more likely to be scheduled than in a medium priority target in Africa. This inequality, if one wishes to call it that, cannot be resolved by "saving" a tape recorder "from" Southeast Asia "for" Africa. Any tape recorder space allocated to, say, Africa is taken from targets in the same region as Africa, like Europe or South America. Any tape recorder space "saved" from Southeast Asia is wasted.

The value of the Lagrange multiplier $L1$ was tabulated for Run ID-R25, 2STA, which is the two-stations case, with simulated weather forecasts. The results are presented in fig. 20. The rows of numbers are the values of $L1$ for adjacent revolutions. The areas of the world are identified also. Checkpoint orbit numbers are given for the first and last values on each row (i.e., row one starts at orbit 16 and ends at orbit 84). Some orbits have two values of $L1$ for cases where a station contact occurred on the orbit, and the optimum value of $L1$ changed. This change point identifies the point at which the tape recorder would be

overfilled if a lower value of L1 were to be used. The obvious alternating pattern in the numbers is due to the elimination of overlapped targets on alternate revs. (Less targets yield fewer overload conditions, therefore, less scheduling problems and lower L1.)

For this run, the world can be roughly divided as follows:

<u>Region</u>	<u>L1</u>
India, Africa, Europe, South America, Arctic, Antarctic, Japan, even days	7
India, Africa, Europe, South America, odd days	5-6
Western Hemisphere Arctic and Antarctic, Australia, even days	2-3
Japan, Australia, odd days	0
Southeast Asia	1

Thus, on even days, value 3 targets in Australia, value 1 targets in Southeast Asia, and value 7 targets in India and Africa are about equally likely to be scheduled.

The factors which govern this distribution are:

- Tape recorder capacity
- Location and duration of ground stations
- Distribution of targets (including overlap and sun angle)

and a change in any factor will change the definition of the geographical regions.

The values of L1 are listed in the day-by-day parameter listings preceding the maps in each simulation.

5.7 FIFTH-BAND MSS NIGHT OPERATIONS

The listing features of the simulation programs were used to identify U.S., Alaskan, and Canadian land masses, and the Sioux Falls and Alaska station cones for the night portions of the ERTS orbit (ascending portion). In all these discussions, revolutions start and end at the northernmost point of the orbit. Thus, the day (descending half) of rev n precedes the night (ascending half) of rev n. Five listings were produced:

<u>Run</u>	<u>Area</u>	<u>Stations</u>
1	U.S.	Sioux Falls
2	U.S., Alaska	Sioux Falls, Alaska
3	U.S., Alaska	Sioux Falls
4	U.S., Alaska, Canada	Sioux Falls
5	U.S., Alaska, Canada	Sioux Falls, Alaska

The simulation program is not presently capable of recognizing night targets or scheduling any real-time targets. To do so would require a much expanded data base and an iterative application of the scheduling algorithm to recorded and real-time targets. At present, the simulation assumes the total period of night contact is available for downlinking sensor data, so a tabulation has been compiled from the two-stations simulation using simulated forecasted weather and the listing for the second night run. This tabulation presents in table 22 data from the 84 orbits which have night targets in the U.S. and Alaska, and contains the following:

<u>Column</u>	<u>Title</u>	<u>Item</u>
1	Rev	Orbit number
2	Night Targets	Number of night target frames (6 frames within 50 s of AOS on orbits 158, 172, 186, and 200 have been included. These orbits are marked by a dash --).

TABLE 22

NIGHT TARGET - DOWNLINK CONFLICT SUMMARY

ORBIT	NIGHT TARGETS	NIGHT CONTACT	DAWN CONTACT	IN CONFLICT		ORBIT	NIGHT TARGETS	NIGHT CONTACT	DAWN CONTACT	IN CONFLICT	
				USED	REMAINING					USED	REMAINING
1	19	40		40	0	19					
2	14	42		30	12	2	126*	34	1	34	1
3	10	22		16	6	4	127	18	42	23	19
4	2	19		16	3		128	18	37	7	30
15	19	40		28	12	7	129	11	20	5	15
16	14	42		4	38		130	2	15	11	4
17	10	22		7	15		140	11	35	16	19
18	2	19		16	3		141	18	42	9	33
28*	1	26	6	32	0	1	142	14	36	11	25
29	19	40		40	0	19	143	10	20	8	12
30	14	41		2	39		144	2	15	8	7
31	10	21		6	15		154	12	36	36	0
32	2	18		16	2		155	19	42	42	0
42*	4	27	3	27	3	1	156	10	35	9	26
43	16	41		21	20		157	9	20	7	13
44	14	41		7	34		158	--	14	6	8
45	10	21		7	14		168	13	36	27	9
46	2	18		18	0	2	169	19	42	24	18
56*	5	28	5	28	5		170	12	34	1	33
57	17	41		41	0	17	171	8	20	5	15
58	14	40		8	32		172	--	12	12	0
59	11	21		3	18		182	14	37	37	0
60	2	18		15	3		183	19	42	39	3
70*	6	30	5	16	19		184	13	32	4	28
71	17	41		12	29		185	6	20	6	14
72	14	40		2	38		186	--	12	4	8
73	10	21		5	16		196	15	38	21	17
74	2	18		11	7		197	17	42	23	19
84*	7	31	5	31	5	2	198	11	29	4	25
85	17	42		9	33		199	5	19	14	5
86	15	40		1	39		200	--	11	11	0
87	10	21		1	20		210	16	38	38	0
88	1	18		18	0	1	211	17	42	41	1
98*	8	33	1	25	9		212	11	22	18	4
99	17	42		9	33		213	4	19	15	4
100	16	39		9	30		224	17	39	39	0
101	11	21		5	16		225	17	42	42	0
102	1	17		10	7		226	11	22	10	12
112*	9	33	3	29	7	2	227	3	19	10	9
113	18	42		22	20		238	18	40	23	17
114	18	38		2	36		239	15	42	23	19
115	11	21		6	15		240	11	22	8	14
							241	2	19	6	13

<u>Column</u>	<u>Title</u>	<u>Item</u>
3	Night Contact	The length of the night contact <u>after</u> removal of 2 frames (50 s) for AOS observation, 2 for LOS observation, and 2 for recorder overhead.
4	Dawn Contact	For the five orbits marked by asterisks, the spacecraft has an Alaska AOS at S/C (spacecraft) dawn. The simulation combines this downlink capability with the night downlink capability, so it is listed here (after AOS, LOS, and overhead deductions) for reference. Note that some are shorter than the allowed "minimum" contacts.
5	Used	This column lists the number of frames downlinked in the simulation.
6	Remaining	Column 3 plus 4 minus 5
7	In Conflict	Column 2 minus 6, if positive

The total number in conflict is 230 frames. This is only a measure of the conflict, not an exact simulation, and it is not quite proper to assume either 230 night MSS frames or recorded frames will be lost. In many cases, the recorded frames could be held on the recorder for another orbit or two. An estimate made by examining the simulation run indicates that only about 50 frames would be lost. However, additional overhead may be incurred in order to break up a night playback into two separate playbacks on either side of real-time night operations.