

2/11/73

**NASA CR-132850**

**9G94F**

**STUDY OF  
SPACECRAFT DIRECT READOUT  
METEOROLOGICAL SYSTEMS**

**FINAL REPORT**

CONTRACT NO. NAS 5-21643

SEPTEMBER 1973

**R. BARTLETT  
Wm. ELAM  
R. HOEDEMAKER**

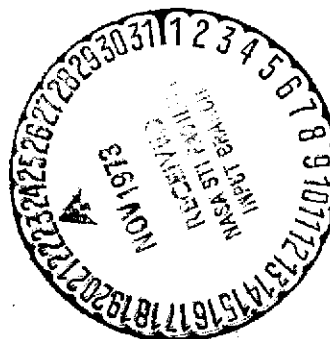

**prepared for  
NATIONAL AERONAUTICS AND SPACE ADMINISTRATION  
GODDARD SPACE FLIGHT CENTER  
GREENBELT, MARYLAND 20771**

(NASA-CR-132850) STUDY OF SPACECRAFT  
DIRECT READOUT METEOROLOGICAL SYSTEMS  
Final Report (Allied Research Associates,  
Inc.) -196 p HC \$12.00 CSCL 22E

N74-10799

192

Unclas  
G3/31 21808



**ALLIED RESEARCH ASSOCIATES, INC.**  
FRIENDSHIP AIRPORT, P.O. BOX 536, BALTIMORE, MD. 21208 (301) 766-5000

9G94F

**STUDY OF  
SPACECRAFT DIRECT READOUT  
METEOROLOGICAL SYSTEMS**

**FINAL REPORT**

CONTRACT NO. NAS 5 - 21643  
SEPTEMBER 1973

**R. BARTLETT  
Wm. ELAM  
R. HOEDEMAKER**

**prepared for  
NATIONAL AERONAUTICS AND SPACE ADMINISTRATION  
GODDARD SPACE FLIGHT CENTER  
GREENBELT, MARYLAND 20771**



**ALLIED RESEARCH ASSOCIATES, INC.**  
FRIENDSHIP AIRPORT, P.O. BOX 536, BALTIMORE, MD. 21203 (301) 766-5000

1

## FOREWARD

The study described in this report was performed by Allied Research Associates, Inc., with major inputs by the Astro-Electronics Division of RCA and EPSCO, Inc. The work was done under sponsorship of the National Aeronautics and Space Administration, Goddard Space Flight Center, Contract No. NAS5-21643.

The authors wish to acknowledge the valuable assistance provided throughout the study by Mr. J. R. Silverman and Mr. C. Vermillion - Technical Monitors for NASA, by Mr. R. Popham of NOAA, by Mr. Romeo Sabatini of ARA, by Mr. W. Haneman and John Danko of RCA, and by the many users who provided the requirements data base for the study.

## SUMMARY

### 1. Purpose of Recommended Space Systems

The purpose of the study was to define the characteristics of the next generation direct readout meteorological satellite system with particular application to Tiros N. Both space and ground systems are included.

The recommended space system is composed of four geosynchronous satellites and two low altitude satellites in sun-synchronous orbit.

The geosynchronous satellites transmit to direct readout ground stations via a shared S-band link, relayed FOFAX satellite cloud cover pictures (visible and infrared) and weather charts (WEFAX). Basic sensor data is transmitted to regional Data Utilization Stations via the same S-band link. Basic sensor data consists of 0.5 n.m. sub-point resolution data in the 0.55 - 0.7  $\mu\text{m}$  spectral region, and 4.0 n.m. resolution data in the 10.5 - 12.6  $\mu\text{m}$  spectral region.

The two low altitude satellites in sun-synchronous orbit provide data to direct readout ground stations via a 137 MHz link, a 400 MHz link, and an S-band link as listed below:

#### Data Content of Low Altitude Satellite Transmission Links

<u>Data</u>	<u>Resolution</u>	<u>Transmission Link</u>
Visible	0.5 n.m. sub-point	S-band; 400 MHz
Near IR	0.5 n.m. sub-point	S-band; 400 MHz
IR	0.5 n.m. sub-point	S-band; 400 MHz
Water Vapor	2.0 n.m. sub-point	S-band; 400 MHz
Visible	2.0 n.m. constant	S-band; 400 MHz, 137 MHz
Near IR	2.0 n.m. constant	S-band; 400 MHz
IR	2.0 n.m. constant	S-band; 400 MHz, 137 MHz
Temp. Profile	15 n.m. per sample	S-band; 400 MHz, 137 MHz
Time Marks, Etc.		S-band; 400 MHz, 137 MHz

### 2. Method

Users of direct readout data and operators of direct readout stations were queried by means of questionnaires and personal interviews as to their usage of and experience with present systems and their requirements for improvements in future

systems. Users queried included private and government, both foreign and domestic.

It was originally intended to do a comprehensive "grass-roots" survey of the users at the operational station level. Some one hundred and fifty questionnaires were to be distributed. This method would have provided a comprehensive and wide ranging input of responses from the working level. However, this objective was only partially achieved. For major U.S. Government users, individual station replies were received from the U.S. Navy, while the U.S. Air Force and the National Weather Service chose to provide consolidated agency replies. Domestic private sector users (commercial, educational, and hobbyists) were also queried. The input from foreign users was obtained primarily through the office of the NOAA, NESS APT Coordinator.

The dominant characteristic of the user replies was diversity. Even among operational users there is a wide range of uses which is made of direct readout data. Among operational meteorological forecasters who are considered in this study to be the dominant user group, the two principal factors are the nature of the forecast mission and the availability of data from alternate sources. For forecasters operating in data poor areas, direct readout data is a prime aid. For forecasters operating in data rich regions, the importance of direct readout data depends upon the type of forecasting done. For general area forecasts it is comparatively much less important than in detailed short range forecasts in support of important weather sensitive operations. And for the latter type forecasts in data poor regions direct readout data is of prime importance. Direct readout data is used to support weather analysis. This usage is very important in data poor regions, much less so in data rich regions.

From replies to the user questionnaire, a list of specific user requirements was prepared, this list shown below was used as a set of required performance design objectives for the new direct readout system.

- a) Increase frequency of observations to at least every 6 hours.
- b) Improve quality of ground station recording and display equipment.
- c) Increase resolution to 2, 0.5, 0.25 n.m.
- d) Provide for automatic gridding.
- e) Remove image distortions.

- f) Promote training in image interpretation. Produce a Direct Readout User's Guide aimed at the broadcast meteorologist.
- g) Develop a method to determine cloud tops by temperature and/or brightness contouring.
- h) Transmit vertical temperature soundings via WEFAX.
- i) Improve gridding accuracy and facility.
- j) Provide means to distinguish between snow cover and clouds.
- k) Provide for ice and snow detection through clouds.
- l) Provide color enhancement.
- m) Increase side coverage to eliminate gaps between swaths in tropics.
- n) Increase dynamic range of the transmitted signal output for the meteorologically useful IR data.
- o) Improve signal to noise ratio of sensors, and the power output of transmitted signal.
- p) Improve NEAT of IR sensors to be less than  $1^\circ$  at  $200^\circ\text{K}$ .
- q) Include water vapor channel at 6.5 and 22  $\mu\text{m}$ .
- r) Provide for continuous onboard calibration of all SR data.
- s) Provide distinctive phase marks for each different transmitted signal.
- t) Develop a low-cost, high-quality display device which will work with all modes of DR transmission.
- u) Provide capability of onboard data storage and "dump" at a preselected time.
- v) Provide method of rectification to polar stereographic and mercator map projections.
- w) Transmit time mark on imagery to facilitate gridding.
- x) Use standard television video for reception of DR images.
- y) Provide quicker transmission of satellite photos over facsimile lines.

In retrospect, the user survey would have been more meaningful if the responders had been aware of the capability that would be feasible in future direct readout systems. In effect, they were asked how they liked the present service and then, comparing that to their operational requirements, what improvements would

they like. A more meaningful questionnaire would present a list of feasible technical improvements or groupings of compatible technical improvements along with the costs of these improvements. Realistically, a customer can make a sensible order only if he knows what is available, what is the cost, and how much can he afford.

Based on this user survey, two broad conflicting requirements were determined. The first was the need expressed by many users to be able to continue to use their present ground equipment with few or minor changes; the second was the need for a marked improvement in the amount and types of data and means to facilitate processing, display, and interpretation.

The needs of the "status quo" group are satisfied by transmitting analog data on VHF (137MHz) in the recommended system. Two channels of data (visible and IR) are provided. The cross track resolution is constant at 2 n.m., and the scan rate is 120 lines per minute. Radiance data from the IR temperature humidity sounder is included. It is not assumed that full utilization of this radiance data is possible by this class of users, but the additional data load is minimal and so the temperature humidity radiance data is included.

The needs of the second group are satisfied by transmission via S-band or the 400 MHz link:

- 1) Four spectral channel data, three corrected to provide 2 n.m. constant resolution along the scan.
- 2) Four channel variable resolution (0.5 n.m. sub-point except 2.0 n.m. water vapor channel) data. The spectral channels are visible, near IR, IR, and water vapor.
- 3) Radiance data from the IR temperature humidity sensor.

The user who wants to continue using his present ground equipment can do so by receiving the VHF transmission. The constant resolution data in visible and IR along with the temperature humidity radiance data will provide this type user with a significantly more useful product with only minor changes required in his ground equipment - a change in the scan rate to 120 lines per minute.

The user with greater needs and greater resources will have to invest in a new ground station. This ground station will be modular reflecting the differing requirements of the users. The basic elements will be an automatic tracking S-band or 400 MHz antenna, a quadrature modulation receiver, a digital bit

synchronizer and formatter to select for storage only the data required, a storage device, and a display device. Stations also will require a data processing device such as a minicomputer which will also perform antenna programming and control functions. The cost of this type station, although varying significantly with required performance, is expected to be on the order of \$100,000.

The 400 MHz link is included in the recommended system in order to provide an incremental step between the VHF link and the S-band link. Since the VHF link is bandwidth limited, the small VHF user who wishes to improve his capability to use more data and to use the more desirable digital data must change to 400 MHz or S-band. Although it appears that the incremental cost change in going above VHF capability may be less by using the 400 MHz link rather than S-band, it is by no means clear cut. A more detailed study on this point based on definitive performance and environmental specifications pertinent to the individual user needs is recommended.

### 3. Meeting the User Requirements

In developing a feasible system to meet the above listed requirements, each item was examined with respect to its technical feasibility and interaction within the system. In addition, the investigation was based on the following assumptions:

- 1) There are no "a priori" restrictions on the number or size of the spacecraft in the system.
- 2) Low altitude and geostationary satellites may be considered.
- 3) Communication links will be constrained to standard frequency allocation limits.
- 4) The spacecraft will perform global data gathering for central processing in addition to the direct readout function.
- 5) Direct readout stations may be located anywhere on the earth, necessitating global coverage.
- 6) Direct Readout ground stations will be either:
  - a) Class 1 - large regional distribution centers
  - b) Class 2 - stations with important forecasting responsibilities which can afford to significantly upgrade their ground stations.
  - c) Class 3 - VHF stations which will remain in operation with minor modifications.



Other factors were considered in configuring the system. The format of the transmitted data should, when possible, conform to the facsimile standards of the World Meteorological Organization (WMO). As new systems are developed, criteria of resolution and system bandwidth require variations of these standards. Line rates of 120 lines per minute (lpm), the WMO standard, or rates integrally related to 120 lpm, can be provided while satisfying other system constraints.

In developing the elements of the system to meet the user's requirements within the above guidelines in most instances a number of possible methods or systems were developed. These are described in detail in the body of the report. Trade-off analyses were performed, and a feasible four-phase spacecraft development system was arrived at. Upon further review it was concluded that this was unnecessarily complicated, and that it was obviously feasible to proceed directly to a recommended system.

#### 4. The Recommended System

The recommended space system includes two low altitude satellites in sun-synchronous orbits at an altitude of 907 n.m., and four satellites in geostationary orbits. The geostationary satellites and associated ground stations are essentially of the type of those presently planned. This geostationary system is developed and will go into operation soon. Significant and feasible technological improvements are relatively much more difficult and farther in the future than improvements in the low altitude sun-synchronous systems.

The geostationary satellites have a FOFAX/WEFAX data relay link at S-band and a spin-scan camera which provides 0.5 n.m. data in the 0.55 to 0.7  $\mu\text{m}$  spectral region and 4 n.m. data in the 10.5 - 12.6  $\mu\text{m}$  spectral region. The geostationary satellite has the capability of providing observations every 30 minutes between a north and south latitude limit of 40 degrees.

There will be two types of field stations served by the geostationary system; regional Data Utilization Stations (DUS) and direct readout stations. Both stations will be served by the same S-Band 1690 MHz, 20 watt transmitter. The DUS will have a 15' antenna and an uncooled parametric preamp. This station will be capable of receiving the stretched retransmitted VISSR data. The direct readout stations will use the recommended S-band ground station. These stations will receive the relay of FOFAX satellite cloud cover pictures and weather charts (WEFAX).

Since each function requires the full power of the transmitter in the satellite, the VISSR data, the stretched VISSR data, and the FAX transmissions must time-share the transmitter. The facsimile data relay will provide imagery and processed meteorological data to the smaller direct readout stations transmitted from the large stations.

The two sun-synchronous satellites at 907 n.m. orbital altitude have an orbital period of two hours. The local times for equator crossing are 9:00 a.m. and 3:00 p.m. The sensing system consists of two principal components, an infrared temperature humidity vertical profile radiometer, and a four spectral channel scanner. The spectral channels are visible (0.5-0.7  $\mu\text{m}$ ), near IR (0.7-1.0  $\mu\text{m}$ ), IR (10.5-12.5  $\mu\text{m}$ ), and water vapor (6.5-7.0  $\mu\text{m}$ ). The sub-point resolution is 0.5 n.m., except 2 n.m. for the water vapor channel.

For direct readout stations the scanner and atmospheric vertical profile data are transmitted over three communication down-links. A 137 MHz link transmits atmospheric profile radiance data and constant 2 n.m. resolution visible and IR data with geometric correction in the scan direction. The data are analog on an amplitude modulated 2.4 KHz subcarrier at a 120 line per minute scan rate. The data are not geometrically corrected in the direction along the orbital track. The resolution at the subpoint in this direction is 1.5 n.m. Two minute time marks appear in the data.

The 1.7 GHz S-band and 400 MHz quadrature modulated digital links transmit the vertical profile data, four spectral channel scanner data, constant resolution and variable resolution. For all channels except the water vapor channel, the data are geometrically corrected to constant 2 n.m. resolution in the scan direction. The resolution is 1.5 n.m. along the orbit path. The scan rate is 120 lines per minute. The water vapor channel scan rate is 120 lines per minute, and the resolution is 2 n.m. by 1.5 n.m. at the sub-point with no geometric correction. The four spectral channel data is also transmitted at full resolution (0.5 n.m. sub-point resolution except 2.0 n.m. subpoint water vapor channel) not geometrically corrected along the scan. The scan rate is 360 lines per minute, except 120 lines per minute for the water vapor channel. A two minute G.M.T. time code is included.

The spacecraft also contains a separate transmitter to transmit global data to the Command and Data Acquisition stations. This system is not a part of the direct readout system.

Although it is necessary for practical reasons to have a specific spacecraft system, it is not desirable nor necessary to have a standard ground station. The great diversity of user requirements and the classification of meteorological users into three classes has been described above. The Class 3 user can continue to receive data on the 137 MHz analog link with presently installed equipment with the scan rate adjusted to 120 lines per minute. The data will be in two spectral channels, visible and IR, and will be constant 2 n.m. resolution along the scan.

The ground station for the Class 1 user is unspecified. A 10-12 foot dish is sufficient to receive the direct readout data from the low altitude satellites. The other elements of the ground station will be as required for the particular mission of the station, but will perform functions similar to the Class 2 stations and, in general, will be more complex and have a higher capacity for data.

The ground station for the Class 2 user whose requirements are the principal basis for the analysis and the recommendations in this study is new. This type of user was characterized by having limited resources, but having requirements for major improvements in amounts and types of data received and in procedures for using the data. The Class 2 station will receive the S-band direct readout transmission with a 5-10 foot dish, depending on location and mission. The receiver will receive quadrature phase modulation. The received signal must be broken down by a digital bit synchronizer and formatter so that only the required bands (and portion of some bands) need to be stored. It is expected that most stations will use the 4 channel, 2 n.m. constant resolution data and that portion of one (visible or IR selectively) variable resolution channel where the resolution is 1 n.m. or better ( $\sim 75\%$ ) as well as the sounding data. The storage requirement is on the order of 100-140 million bits per ten minute pass. The data are stored in a disc file to permit fast call-up of any portion of the data for any stored channel. A mini-computer for data processing, one or more display devices, and an operator's station complete the main elements of the ground station. Both hard copy and video display devices are included.

Functions accomplished with this ground station include:

- 1) grid computation
- 2) antenna pointing
- 3) low resolution display of any channel on hard copy
- 4) high resolution display of operator selected areas of the video

for any channel on the dynamic display.

- 5) operator control of brightness/radiance transfer function about any operator selected brightness level.
- 6) gamma slicing (for radiance level identification) at any operator selected level.
- 7) superposition on visible data of points where IR channel data crosses an operator selected threshold.
- 8) grid adjustment through operator fitting of grid to lat. -long. fiducials or points of known geography.

## 5. Resulting Benefits to Users

Although the users of direct readout data have widely diverse interests, the meteorological users have been divided into three classifications, and we have given particular emphasis to the Class 2 users whose needs have received special attention as the basis for the design of the system. Their function is to provide operational, specific short-to-medium-range forecasts. Their requirements for direct readout data are characterized by reliability, timeliness and facility of use.

Reliability includes both the assurance of receiving useable data and the accuracy of the data. Reliability is improved by providing calibrated digital data and improving the communication link.

Timeliness is essential in the use of direct readout data in support of detailed operational forecasting. The two principal factors involved are frequency of observation and processing time. Six-hour observation intervals for the sun-synchronous and 30-minute intervals for the geostationary satellite are provided.

Timeliness is also a factor in "facility of use," and is provided by automatic handling of the data. Facility of use also implies that the forecaster must be able to use the multiband imagery rectified and gridded singly or comparatively and he must be able to do this rapidly and accurately. This system provides a marked increase in service to the forecaster in enabling him to make rapid and accurate decisions efficiently using the mass of information available from the satellite without a large investment in time and manpower.

## TABLE OF CONTENTS

	<u>Page</u>
FOREWARD	ii
SUMMARY	iii
LIST OF FIGURES	xvii
LIST OF TABLES	xix
SECTION 1	
REVIEW OF CURRENT AND PLANNED DIRECT READOUT SYSTEMS	1
1.1 Current Spacecraft Direct Readout Systems	1
1.1.1 Description of ESSA-8 Direct Readout System	2
1.1.2 Description of Nimbus 4 Direct Readout System	3
1.1.3 Description of NOAA-2 Direct Readout System	4
1.1.4 Description of ATS-1 and ATS-3 Direct Readout System	5
1.1.5 Department of Defense Weather Satellite	5
1.2 Planned Spacecraft Direct Readout Systems	5
1.3 Existing Direct Readout Ground Systems	7
1.3.1 VHF APT-Type Direct Readout Station	7
SECTION 2	
ANALYSIS OF USER REQUIREMENTS	11
2.1 Purpose and Results	11
2.2 Current Usage	11
2.2.1 Scope and Type of Users	11
2.2.2 Sampling User Opinion	12
2.2.3 Results from the Questionnaire and other Supporting Alternate Methods	13
2.2.4 Further Interpretation of Replies from U. S. Government Users	17
2.2.5 Replies from Domestic Private Sector Users	19
2.2.6 Foreign Users and Domestic Private Individuals	21

## TABLE OF CONTENTS (cont)

	<u>Page</u>
2.3 Baseline for Defining an Unconstrained Spacecraft Direct Readout System	22
2.3.1 List of User Requirements and Recom- mendations for Improvement	22
2.3.2 Classification of Users	23
2.3.2.1 Differences Among Users	24
2.3.2.2 Preliminary Classification of Users	25
2.3.2.3 Small Stations with Important Responsibilities	26
2.3.2.4 Radio Frequency Interference	28
2.3.3 User Types - Characteristics and Data Requirements	29
2.3.3.1 Large Station	29
2.3.3.2 Small Stations with Large Operational Forecasting Responsibilities	30
2.3.3.2.1 Characteristics	30
2.3.3.3 Other Small Stations	31
2.4 Comment on User Requirements	32
SECTION 3	
<b>ELEMENTS OF THE UNCONSTRAINED SYSTEM AND TRADE-OFF ANALYSIS</b>	33
3.1 Summary Restatement of Priority User Require- ments	33
3.2 Requirements Trade-Off Analysis	36
3.2.1 Period Between Observations	36
3.2.1.1 Sun-Synchronous Orbit	36
3.2.1.2 True Polar Orbit	40
3.2.1.3 Geostationary Orbit	41
3.2.1.4 Summary	41
3.2.2 Sensors	41
3.2.2.1 Vertical Sounder	41

TABLE OF CONTENTS (cont)

	<u>Page</u>
3.2.2.2 Radiometer	45
3.2.2.2.1 Low Altitude Orbit Sensor	46
3.2.2.2.2 Geostationary Altitude Sensor	52
3.2.3 Communications	53
3.2.3.1 Low Altitude Satellite Communications	55
3.2.3.2 Communications from Geostationary Altitude	63
3.2.3.3 Trade-offs	65
3.2.4 Data Handling	71
3.2.4.1 General	71
3.2.4.2 Reduced Area Transmission of High Resolution Data	72
3.2.4.3 Digital or Analog Data	76
3.2.5 Displays	77
3.2.5.1 Direct View Storage Tube Versus CRT	80
3.2.6 Processes to Facilitate Data Interpretation	82
3.2.6.1 Rectification	82
3.2.6.1.1 Ground Station	83
3.2.6.1.2 Spacecraft	83
3.2.6.1.3 Conclusion	87
3.2.6.2 Sensor Calibration	87
3.2.6.3 Ephemeris and Time Code	88
3.2.6.4 Gridding	91
3.2.6.5 Gamma Control	96
3.2.6.6 Mapping	99
3.2.6.7 Temperature and Reflectance Contouring	99

TABLE OF CONTENTS (cont)

	<u>Page</u>
3.2.6.7.1	Spacecraft 99
3.2.6.7.2	Ground Station 100
3.2.6.8	Superposition of IR and Visible 101
3.2.7	Special Operating Functions 101
3.2.7.1	Antenna Programming 101
3.2.7.2	Dynamic Gain Control 102
3.2.7.3	Data Storage and Dump 102
3.2.8	Special Problem Observations 103
3.2.8.1	Ice and Snow Detection 103
3.2.8.2	Cloud/Snow Discrimination 103
3.2.8.3	Ice and Snow Detection through Clouds 104
3.2.8.4	Conclusion 104
3.3	Ground Functional Components 104
3.3.1	Receiving 104
3.3.2	Processing 107
3.3.3	Display 108
3.4	Summary of Trade-Off Analyses 108
SECTION 4	DEVELOPMENT OF THE SPACECRAFT SYSTEM 111
4.1	Summary of the Feasible System 111
4.1.1	User Requirements as Related to Station Size 112
4.1.1.1	Class 1 User 112
4.1.1.2	Class 2 User 112
4.1.1.3	Class 3 User 112
4.1.2	Relation between the Feasible System and the User Requirements 112
4.1.3	Evolution of the System 114
4.1.3.1	Step 1 (One Spacecraft, Altitude 790 n.m.) 116



TABLE OF CONTENTS (cont)

	<u>Page</u>
4.1.3.2 Step 2 (One Spacecraft, Altitude 790 n.m.)	121
4.1.3.3 Step 3 (Two Spacecraft with Orbit Adjust System at 907 n.m.)	129
4.1.3.4 Step 4 (Two Spacecraft with Orbit Adjust System at 907 n.m.)	132
4.1.4 Miscellaneous Processing	133
4.1.4.1 Time Marker	133
4.1.4.2 Ephemeris Data Relay	135
SECTION 5 RECOMMENDED SYSTEM	136
5.1 Spacecraft System	136
5.1.1 Geostationary Satellites	136
5.1.2 Low Altitude Satellites	137
5.2 Recommended Ground Station Configuration	142
5.2.1 Class 2 Users Ground Station	142
5.2.1.1 Operator Controls	145
5.2.1.2 Geostationary Satellite Data	148
5.3 Resulting Improvements in Meteorological Services	148
5.3.1 Reliability	149
5.3.2 Timeliness	149
5.3.3 Facility of Use	149
REFERENCES	151
BIBLIOGRAPHY	152
APPENDIX A DESCRIPTION OF PRESENT DIRECT READOUT SYSTEMS	155
APPENDIX B QUESTIONNAIRE - TO DETERMINE NEW APPLICA- TIONS FOR DIRECT READOUT DATA FROM SATELLITES	161
APPENDIX C REVIEW OF PLANNED SENSORS AND SPACECRAFT DIRECT READOUT SYSTEMS	166

## LIST OF FIGURES

<u>Figure No.</u>		<u>Page</u>
1-1	World Wide Distribution of APT Receivers	9
1-2	Block Diagram of APT Receiver Station	10
3-1	Altitude vs. Earth Central Angle for Coverage to Local Zenith Angle of $65^\circ$	38
3-2	Minimum Number of Spacecraft and Altitude for Global Coverage every 3 to 6 Hours in Sun-Synchronous Orbit	39
3-3	Coverage from Three Geostationary Spacecraft over Equator, Edge-to-Center Resolution 2.8 n.m. at $65^\circ$ Zenith Angle	42
3-4	Coverage from Four Spacecraft over Equator; Edge-to-Center Resolution 2.8 n.m. at $65^\circ$	43
3-5	Earth Central Angle and Nadir Angle vs. Spacecraft Altitude for a Zenith Angle of $65^\circ$	48
3-6	Nadir Angle for Contiguous Coverage for a Single Satellite in a Sun-Synchronous Orbit	49
3-7	Earth Central Angle Required for Contiguous Coverage at Equator by a Single Satellite	50
3-8	Edge-to-Center Resolution Ratios $-e_p$ and $e_n$ , Sun-Synchronous Orbits	51
3-9	Optics Size for a Radiometer at Geostationary Altitude	54
3-10	Signal to Noise Ratio vs. Video Baseband, Trade-off for Present VHF Real Time Stations	56
3-11	Signal to Noise Ratio vs. video Bandwidth, Trade-off for the Maximum Bandwidth Allocation of 90 kHz at 137 MHz	57
3-12	Signal to Noise Ratio vs. Video Bandwidth, Trade-off for the Maximum Bandwidth Allocations of 300 kHz at 400 MHz	58
3-13	VHF Real Time Link Capability	59
3-14	Data Rates for Real Time High Resolution Data for Low Altitude Spacecraft (Digital Processing for Bandwidth Optimization is Assumed)	61
3-15	Digital S-Band Link from Low Altitude Spacecraft	62
3-16	Transmitter Power and Bit Rate vs. Ground Antenna Size for Geostationary to Ground Station S-Band Link	64
3-17	Solar Array Degradation after 2 years as a Function of Altitude	68
3-18	Delta 2910 Spacecraft Weight Capability (WTR Launch), Fixed Array, $\sigma = 60^\circ$ max.	69

LIST OF FIGURES (cont)

<u>Figure No.</u>		<u>Page</u>
3-19	Program Power System Cost	70
3-20	Illustration of Swath Subdivision	74
3-21	Spacecraft Antenna Patterns for Subswath Data Channels	75
3-22	Example of Unrectified Data ITOS-D-VHRR, Resolution 1/2 n.m. at the Sub-Point	84
3-23	Example of Rectified Data of Figure 3-22, Resolution 2.0 n.m.	85
3-24	Scan Correction via Variable Scan Rate	86
3-25	Circuitry for Automatic Continuous Calibration of Sensor/Digitizer	89
3-26	Grid Data Processing	93
3-27	Spacecraft Hardware for Generation of Lat/Long "Fiducials"	95
3-28	Circuit for Brightness/Radiance Amplification	98
4-1	Cylindrical Antenna Gain	119
4-2	ITOS Direct Readout Modification, Step 1	120
4-3	ITOS Direct Readout Modification, Step 2	123
4-4	Direct Readout Systems, Step 3	130
5-1	Recommended Direct Readout Spacecraft System	139
5-2	Block Diagram of APT Receiver Station	143
5-3	Operations Control Panel	144

LIST OF TABLES

<u>Table No.</u>		<u>Page</u>
1-1	Current (December 1972) Direct Readout Spacecraft	2
1-2	Characteristics of the ESSA-8 APT	3
1-3	Planned Direct Readout Spacecraft	6
1-4	Number of Direct Readout Ground Stations since 1964	8
2-1	Ranking of Suggested Improvements (U. S. Navy)	18
3-1	Summary of User Requirements Affecting Satellites	35
3-2	Sun-Synchronous Orbit Spacecraft Systems	40
3-3	Polar Orbit Spacecraft Systems	40
3-4	Feasible Satellite System to Satisfy Observation Frequency	44
3-5	Requirements for Radiometer Data	45
3-6	137 MHz Parameters	60
3-7	Typical Antenna Subsystems for VHF, UHF, and S-Band	106
3-8	Summary Analysis of Feasible Processing Requirements	109
4-1	User Requirements vs. Feasible System	113
4-2	VHF Link Calculation Step 1	117
4-3	Overall System S/N of Real-Time SR Data at Local APTGS (ITOS D and Step 1 Improvement)	118
4-3a	Beacon Transponder Link S/N	122
4-4	S-Band Link Step 2	124
4-5	400 MHz Link Step 2	126
4-6	137 MHz Link Step 2	127
4-7a	Step 2 Weight and Power Changes	125
4-7b	S-Band Link Alternate Step 2, 2 Channel Digital	128
4-7c	Alternate Step 2 Weight and Power Changes	129
4-8	400 MHz and S-Band Links Step 3	131
4-9	Step 4 Weight and Power	132
4-10	One of Four S-Band Links Step 4	134
5-1	Data Content of S-Band Direct Readout Link	138
5-2	S-Band Link Calculation (900 n. m. Altitude)	141
5-3	Recommended System Weight and Power	142
5-4	Processor Utilization	146
5-5	Data Storage Requirements	147
A-1	Manufacturers of APT Ground Stations	158
C-1	TIROS N Sensor Payload	170

## 1. REVIEW OF CURRENT AND PLANNED DIRECT READOUT SYSTEMS

The transmission of cloud cover pictures directly from orbiting spacecraft to local users all over the world, using inexpensive ground stations, was initiated in 1963 with TIROS VIII. Since then, spacecraft in each of the TIROS, NIMBUS, and ITOS series have had APT (Automatic Picture Transmission), and more recently, DRSR (Direct Readout Scanning (VIS and IR) Radiometer) capabilities. The very high resolution direct readout data from ITOS-D (called NOAA-2 after launch) which can be received with moderately priced ground station equipment, are providing cloud information of great detail and even greater utility.

The direct readout system is a widely visible form of space technology utilization because the results of the complex development of sensors, spacecraft, and ground equipment are of immediate use to the local meteorologist. The data has particular application for islands and other geographically remote locations where supporting ground observations are sparse. Even in relatively data-rich countries, however, direct readout information is potentially useable by government agencies, the military, universities, port authorities and airports, shipping companies, and private meteorological services including the commercial broadcasting industry.

### 1.1 Current Spacecraft Direct Readout Systems

As of December 1972, there are five spacecraft equipped with direct readout capabilities in operation. Three are in polar sun-synchronous orbits, while two are geostationary. The polar orbiting satellites include ESSA-8, NOAA-2, and Nimbus 4. The two geostationary satellites in operation are ATS-1 and ATS-3. Both geostationary satellites transmit WEFAX (Weather Facsimile) data on a scheduled basis, on APT-compatible frequencies. The Nimbus 4 Real Time Transmission System (RTTS) was reactivated in January 1972, and then used intermittently, principally over Antarctica. The imaging system appears to be functioning normally at this time (December 1972), although satellite attitude control remains a problem.

Neither ITOS-1 nor NOAA-1 has been reactivated since their failures in

mid-1971. Operational use of both spacecraft was terminated because of excessive temperature and voltage anomalies. Table 1-1 lists the current direct readout satellites.

TABLE 1-1

Current (December 1972) Direct Readout Spacecraft

Satellite	Data Transmission Systems	Frequency (MHz)	Inclination (degrees)	Period (minutes)	Height Perigee-Apogee (km)
ESSA-8	APT	137.62	101.8	114.7	1414-1464
NIMBUS-4	RTTS	136.95	100.0	107.1	1088-1099
NOAA-2	SR	137.50	102	115.0	1448-1454
	VHRR	1697.5			
ATS-1	WEFAX	135.6	4.2	24 hours	35,780
ATS-3	WEFAX	135.6	2.5	24 hours	35,780*

\* Average Height

Following is a brief description and status report on U.S. satellites with direct readout capabilities.

1.1.1 Description of ESSA-8 Direct Readout System

ESSA-8 was launched December 15, 1968, and is still operating normally. The local time of equator crossing is 9:59 a.m. (local solar time) descending, drifting about 1.1 minutes each month. The transmission frequency is 137.62 MHz.

ESSA-8 carries two conventional television APT cameras similar to those used on earlier spacecraft. Camera No. 1 has been used almost exclusively throughout the spacecraft's lifetime due to a minor malfunction of Camera No. 2. Recently, slight degradation of Camera No. 1 pictures has been reported by a number of users. If degradation continues, Camera No. 2 may be activated.

The APT system on ESSA-8 is designed to transmit slow-scan television pictures of the earth, each picture covering an area approximately 1700 nautical miles on a side with a 30% overlap between successive pictures along an orbital

track. Resolution is approximately two nautical miles (n. m.) at the subsatellite point. Table 1-2 summarizes the characteristics of the ESSA-8 APT.

TABLE 1-2

Characteristics of the ESSA-8 APT

Lines per Picture	800
Start Signal	3 seconds
Phasing Signal	5 seconds
Transmission Time	200 seconds
Time Interval between Picture Frames	150 seconds
Time Interval between Start of One Picture and Start of Next Picture	358 seconds

1.1.2 Description of Nimbus 4 Direct Readout System

Nimbus 4 was launched April 8, 1970. Direct readout data was provided by the Real Time Transmission System (RTTS). Major components of this system were the Direct Readout Image Dissector Camera System (DRID) which provided visual imagery and the Direct Readout Infrared Radiometer System (DRIR) which provided infrared imagery. The RTTS system was used for nearly one year on a limited basis because of interference with other sensors. Currently, only the visual imagery is provided for about 6-8 orbits per day over Antarctica to support operations there.

The Image Dissector Camera System (IDCS) differs radically from the Automatic Picture Transmission cameras with which users have become familiar during previous Nimbus 1 and 2, TIROS, and ESSA flights. Standard APT cameras consisted of a wide-angle lens, a mechanical shutter, and a storage vidicon on which the complete scene was exposed, slowly scanned, and then erased. Thus, all the pictorial information contained in a single frame was exposed instantaneously from a fixed position in space. The image dissector is a shutterless electronic scan and step tube mounted behind a wide-angle lens. Scanning and stepping functions occur continually while the satellite is progressing along its orbital path; i. e., the earth scene contained in a single frame is not exposed instantaneously from a fixed location in space. The chief advantage of the IDCS over the conventional vidicon cam-

eras is the ability to sense a greater dynamic range, and to produce images with less distortion near the edges. The image is approximately 1400 nautical miles on a side with 50% overlap between successive images. Resolution is approximately two miles at the subsatellite point. The scanning and timing characteristics are the same as ESSA-8 APT (see Table 2) except that the time interval between picture frames is zero.

### 1.1.3 Description of NOAA 2 Direct Readout System

The ITOS-D meteorological satellite was launched on October 15, 1972, and re-designated NOAA-2 after injection into orbit.

NOAA-2 carries a dual channel Scanning Radiometer (SR). Unlike the single-channel real time SR Transmissions of ITOS-1 and NOAA-1, the NOAA-2 SR provides, as a normal mode of operation, two channels of time sequenced data (infrared 10.5-12.5  $\mu\text{m}$  and visible 0.5-0.7  $\mu\text{m}$ ) within a single scan (one revolution) of the 48 rpm radiometer. The infrared occupies the first half of a single scan (625 milliseconds). The visible channel is delayed 625 milliseconds and is inserted during the last half of the scan. Because of darkness, only the infrared channel is useable at night.

The SR is a line scan device; coverage is achieved from continuous horizon-to-horizon cross-track scanning combined with the forward motion of the spacecraft. Resolution is approximately 4 nautical miles for IR and 2 n.m. crosstrack by 4 n.m. along the track for visible at the subsatellite point and decreases toward the horizons.

NOAA-2 also carries a new direct readout system called the High Resolution Picture Transmission (HRPT) Service. This service provides Very High Resolution Radiometer (VHRR) data on S-band frequencies. Acquisition and display of VHRR requires a completely different, more expensive ground station than the conventional APT ground station.

The VHRR is a two-channel scanning instrument sensitive to energy in the visible spectrum (0.6 to 0.7  $\mu\text{m}$ ) and the infrared window (10.5 to 12.5  $\mu\text{m}$ ). Coverage is achieved from continuous horizon-to-horizon cross-track scanning combined with the forward motion of the spacecraft. Resolution is approximately 0.5 nautical miles at the subsatellite point and decreases toward the horizons. Both channels are transmitted, but scans from the two channels are exactly 180° out of phase.



#### 1.1.4 Description of ATS-1 and ATS-3 Direct Readout System

The applications Technology Satellite (ATS) Weather Facsimile (WEFAX) experiment utilizes the VHF imagery which has been received, processed, and retransmitted by a ground station through the VHF subsystem to APT ground stations on a frequency of 135.60 MHz. ATS-1, launched in December 1966, is located near  $149^{\circ}\text{W}$ , while ATS-3, launched in November 1967, is located near  $71^{\circ}\text{W}$ . ATS-1 and ATS-3 broadcasts consist of gridded Spin Scan Cloud Camera (SSCC) imagery and ESSA-9 AVCS imagery processed as Mercator and Polar Stereographic projections. APT Predict (TBUS) messages are also transmitted.

#### 1.1.5 Department of Defense Weather Satellites

Some details on the Department of Defense Weather Satellite program have been released recently. This low altitude satellite system provides imagery at two resolutions; two nautical miles and  $1/3$  nautical miles. The swath width is such that it does not provide complete coverage. It is equipped with sensors that operate in the visual band at very low light levels -- some nighttime imagery is obtained. The data rate is high and the ground stations cost on the order of \$500,000.

#### 1.2 Planned Spacecraft Direct Readout Systems

Table 1-3 lists the planned satellites that will carry direct readout systems.

Follow-on ITOS satellites E, F, and G are planned for launch at approximately nine-month intervals following the launch of ITOS-D (now NOAA-2). Actual launch dates, however, will be determined by the performance of each spacecraft following launch. The launch interval can be reduced to as little as three months, if required. With these planned satellites, direct readout data, mainly from the SR, will be continuously available in the foreseeable future for the present commercial-type receiving stations.

The launch of the first Synchronous Meteorological Satellite (SMS-A), originally scheduled for 1972, has been delayed until early 1974 due to technical and funding problems. Present plans are to launch SMS-A in January 1974 with SMS-B launched about six months later. SMS-A probably will be placed in a geostationary orbit near  $100^{\circ}\text{W}$ ; the location of SMS-B has not been determined as yet, but the successful launch and operation may have an effect upon the future positioning of

TABLE 1-3

Planned Direct Readout Spacecraft

<u>Satellite</u>	<u>Launch Date</u>	<u>Orbit</u>	<u>Direct Readout Sensors</u>	<u>Services</u>	<u>Transmission Frequency (MHz)</u>
SMS-A <sup>(1)</sup>	Jan. 1974	Geostationary	WEFAX VISSR <sup>(2)</sup>	APT HRPT	1690.1 1687.1
ITOS-E	July 1973	Polar	SR VHRR	APT HRPT	137.50/137.62 1697.5
SMS-B	Mid-1974	Geostationary	WEFAX VISSR	APT HRPT	1690.1 1687.1
ITOS-F	Mid-1974	Polar	SR VHRR	APT HRPT	137.50/137.62 1697.5
ITOS-G	Mid-1975	Polar	SR VHRR	APT HRPT	137.50/137.62 1697.5
GOES <sup>(3)</sup>	1975	Geostationary	WEFAX VISSR	APT	1690.1 1687.1
TIROS N	1977	Polar	AVHRR <sup>(4)</sup> AVHRR	APT HRPT	VHF S-Band

- (1) SMS Synchronous Meteorological Satellite  
(2) VISSR Visual Infrared Spin Scan Radiometer  
(3) GOES Geostationary Operational Environmental Satellite  
(4) AVHRR Advanced Very High Resolution Radiometer

ATS-1 and ATS-3 by late 1974. The geostationary SMS satellite series will become operational in 1975 when the operation responsibilities will be transferred from NASA to NOAA. The Geostationary Operational Environmental Satellite (GOES) will be a follow-on to the SMS series and is due for launch in 1975. SMS/GOES will be equipped with WEFAX and VISSR (Visual and Infrared Spin Scan Radiometer) transmission capabilities to local modified APT stations. Various transmission modes are envisioned for VISSR and WEFAX, each requiring a different degree of sophistication for the receiving station. The essential components of the simplest APT station capable of receiving SMS/GOES data would be a six-foot diameter antenna with feed and mount, preamplifier, and a frequency converter.

The TIROS-N satellite planned for 1977 will have both APT and HRPT capabilities. It is foreseen that data from the Advanced Very High Resolution Radiometer (AVHRR) will be processed on board the spacecraft to reduce the amount of data so that it can be transmitted via the VHF APT transmission link. The processing will probably consist of averaging adjacent bits of data, producing an image of lower resolution and lesser data points. The HRPT will transmit AVHRR data at full resolution.

### 1.3 Existing Direct Readout Ground Stations

#### 1.3.1 VHF APT-Type Direct Readout Station

Because of the relatively inexpensive equipment involved in the construction of an APT-type direct readout station, hundreds of APT stations are now in operation in nearly 100 countries. Almost 300 stations exist in the U. S. alone, and about 100 in Europe. APT sets are also known to be located in Eastern Europe, Russia, and Mongolia. Table 1-4 shows the growth and distribution per agency of Direct Readout Ground Stations since the inception of the APT program in 1964. Figure 1-1 shows the worldwide distribution of APT receivers as of October 1971.

There have been many APT receiving systems designed and constructed all over the world since the first Fairchild system was developed in the early 1960's. Each one of these systems includes the same basic elements, the main variables being a) the degree of automation of the tracking and receiving phase, and b) the display flexibility that can be permitted. Figure 1-2 presents a simplified block diagram of an APT station.

NUMBER OF  
DIRECT READOUT GROUND STATIONS SINCE 1964\*

AGENCY	1964	1965	1966	1967	1968	1969	1970	1971
NOAA	12		23	21		23		25
U. S. Air Force	17		37	41		41		34
U. S. Navy	6		25	41		46		33
U. S. Army	1		2	2		2		4
NASA	6		10	13		11		12
Other Governmental Agencies	0		0	0		1		6
Foreign Governmental - Major Meteorological Offices	8		33	42		46		97
Foreign Business - Industry, TV and Universities	1		17	31		51		57
Foreign Private - Mainly Individuals	0		4	11		30		81
U. S. Business - Industry, TV and Universities	6		19	39		53		71
U. S. Private - Mainly Individuals	0		11	41		69		166
<b>TOTALS</b>	<b>57</b>		<b>181</b>	<b>282</b>		<b>373</b>		<b>586</b>

\*Source - NASA and NOAA Questionnaires

TABLE 1-4

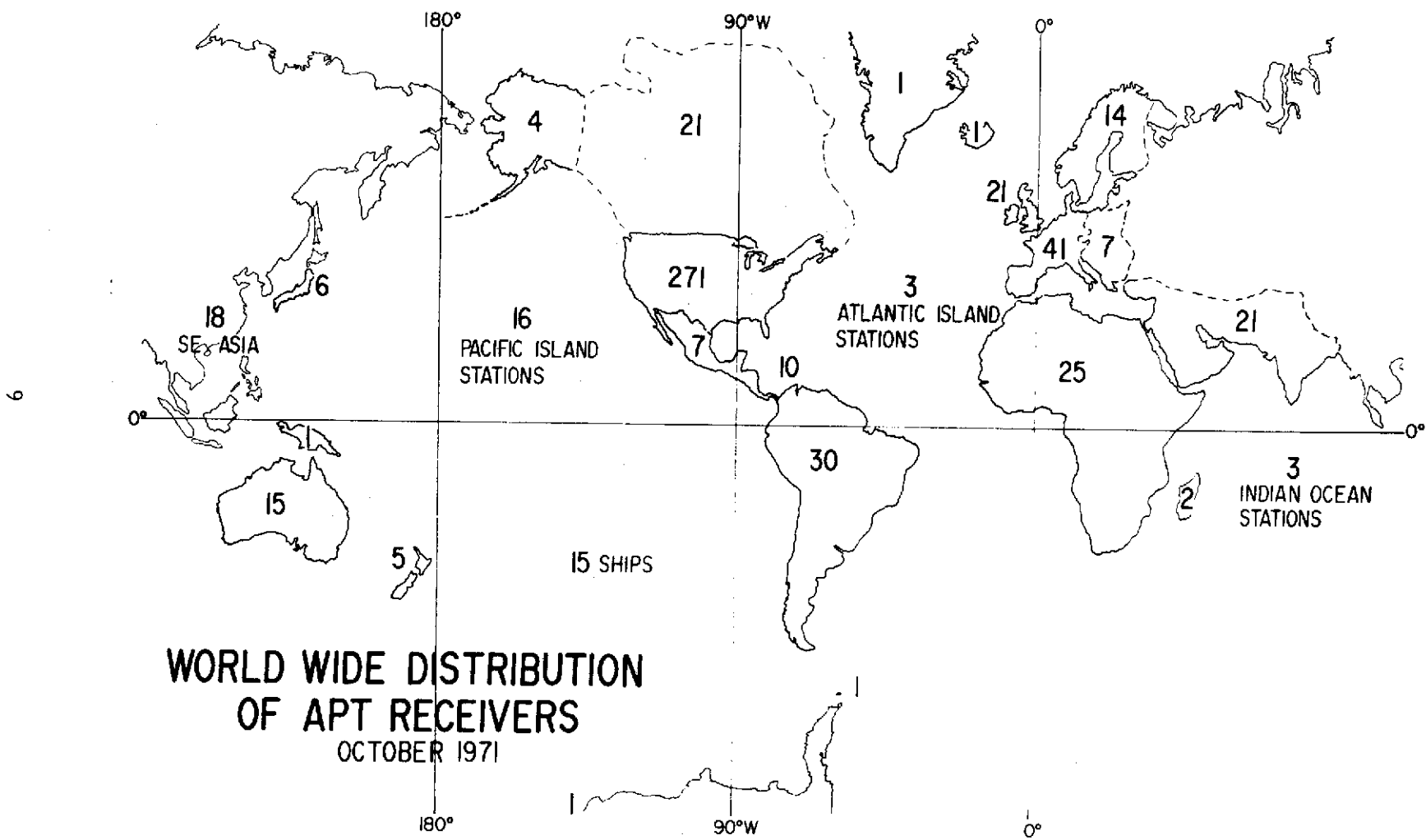

FIGURE 1-1

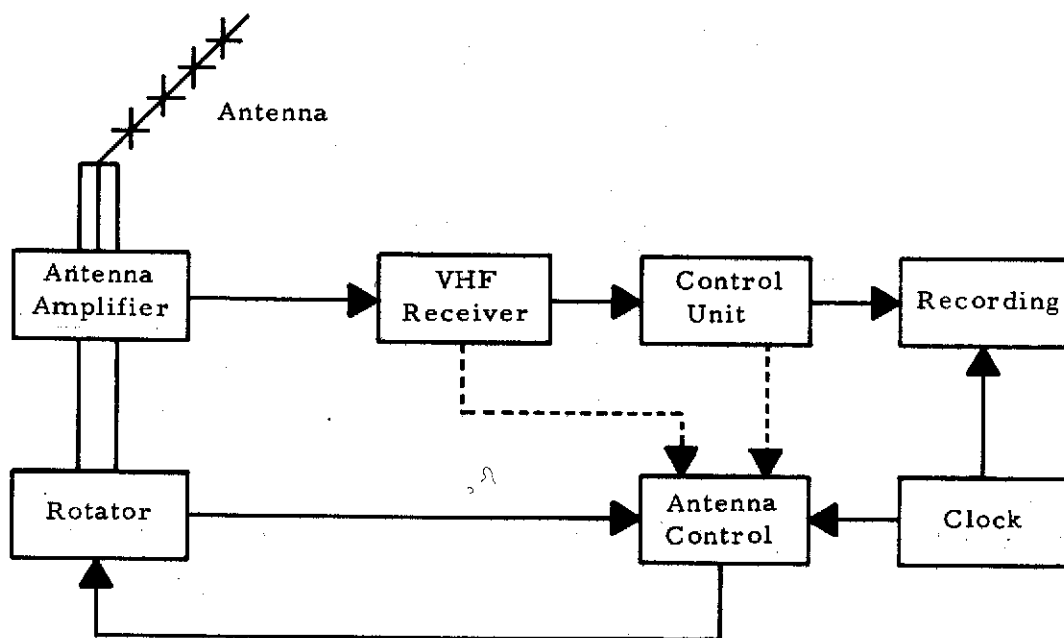

Figure 1-2 Block Diagram of APT Receiver Station

## 2. ANALYSIS OF USER REQUIREMENTS

### 2.1 Purpose and Results

In this section the present usage and future requirements of the users of direct readout data are determined in order to assist in the design of an unconstrained direct readout system of the future.

The results of this determination are that three general classes of users must be considered:

- (1) Large stations having major facilities, broad responsibilities and with requirements for much more direct readout data than are now being provided.
- (2) Small stations with important operational forecasting responsibilities which have limited facilities but require a significant improvement over the data now provided.
- (3) Other small stations with the requirement of continuing to receive direct readout data with little or no change in their ground equipment.

### 2.2 Current Usage

#### 2.2.1 Scope and Types of Users

The users of direct readout data from meteorological satellites are numerous. They are also extremely diversified. They are located throughout the world. They vary from interested amateurs to the national weather services of the largest nations. They do not fit into any organized structure. Their methods are diverse, as are the usages which they make of the data. Thus it was apparent that to plan for direct readout systems in future meteorological satellites these direct readout "customers" should be studied to determine (1) how direct readout data were being used, (2) what these "customers" viewed as the strong and weak points of the past and present systems, (3) what they desired as needed changes and improvements for future direct readout systems.

Table 1-4 indicates the scope of the use of meteorological data from direct readout systems. The steady growth in its use is evidenced by the increasing number of ground stations. It is of interest, however, to note that the number of ground stations operated by the U. S. Government decreased from 118 in 1967 to 114 in

1971. Thus the marked increase from 373 ground stations in 1969 to 586 in 1971 is confined entirely to non-U. S. Government user. It appears that the U. S. Government "market" has been saturated as to number of stations, at least for the types of data available from present satellites and ground systems, and considering the types of forecasting services presently provided. For users with comparatively major meteorological responsibilities, the increase from 1967 to 1971 of 42 to 97 stations by foreign government agencies is particularly significant.

### 2.2.2 Sampling User Opinion

The primary method of determining present usage and future needs of the users of direct readout data was by means of a questionnaire (See Appendix 2-A). In addition, personal interviews were conducted with government and private U. S. users, and conferences held with Government personnel. The questionnaire contained 13 questions on six pages. The first nine questions requested the identity of the user and asked about his familiarity with direct readout data and his use of it. The other questions were concerned with limitations of the direct readout data, personnel training needed, type of ground equipment used, and experience of operation. Suggestions were invited for improvement of future systems.

It was originally intended to distribute this questionnaire to about 150 users. Of these about half were U. S. government agencies and half private meteorologists. The private sector included educational institutions, industrial forecasting companies, commercial broadcasters, and other users. Pursuant to discussions of the matter with government officials, the distribution of the questionnaires was modified. In the end, responses to the questionnaire and information from other alternate methods were received as follows:

- (1) National Weather Service- Consolidated agency reply;
- (2) U. S. Air Force- Consolidated agency reply;
- (3) U. S. Navy- Forty seven individual questionnaires returned;
- (4) Private Sector U. S. - Twenty two questionnaires returned out of fifty six distributed;
- (5) International- User requirements for this sector were obtained from the NOAA APT questionnaire which is distributed annually to direct readout stations all over the world, including foreign and domestic amateurs through the office of the NOAA APT Coordinator.



### 2.2.3 Results from the Questionnaire and Other Supporting Alternate Methods

Sample response to the key questions in the user questionnaire are presented below for those user agencies which operated a significant number of stations. Of the 22 questionnaires returned by the U. S. domestic private sector, only 5 operated direct readout stations. The domestic private sector response will be analyzed in a later paragraph.

(a) Question - "Based on your experience in general, what do you feel are the most significant limitations to the use of these data for your particular mission?"

(a-1) NOAA

"The most significant limitation to the use comes from inadequate ground systems. This includes the display device, the display media, and the distribution systems."

(a-2) USAF

"The most significant limitation is the inability to readily extract meteorological parameters from satellite imagery, e. g., cloud tops/amounts, jet location and intensity, severe weather location and intensity, etc. This problem is inherent to reduction of satellite imagery to parametric values."

(a-3) USN

1. Lack of current operational satellite with DRIR capability coupled with infrequency and improper timing of observations (number of satellite passes).
2. Current spatial resolution of sensors.
3. Perishability of relayed information (stored data, FOFAX, remotes, etc.).
4. Gridding problems including accuracy.
5. Inability of satellite sensors to adequately resolve meteorological information such as precipitation and intensity of precipitation, cloud heights, snow

- and ice (particularly when obscured by cloud cover).
6. Level of training and experience of interpreters.
  7. Lack of coverage of complete area of interest and responsibility of the meteorological unit concerned."

(b) Question - "If you are a current user of DR data, please indicate your mode of operation, receiving and display equipment, other capabilities of your system and types and frequencies of problems you encounter with the system."

(b-1) NOAA

"Our mode of operation is hybrid, i. e. , we have both direct readout and reception of direct readout remoted from a few major readout sites via facsimile network. All of our receiving equipment is Fairchild. The display equipment now consists of: Muirhead K-300, Alden 10, Fairchild, and EMR CRT-Polaroid. The greatest problems encountered thus far are the AGC operation on the Aldens. The electrolytic paper media used on the Alden and Fairchild are only marginal in usefulness, especially the sepia paper on the Alden equipment. Another very serious problem is that the spacecraft is designed for the convenience of the spacecraft and not for the users. The proliferation of formats and scan speeds results in large scale confusion and rapid obsolescence of equipment."

(b-2) USAF

"Of our 32 direct readout stations, 9 receive satellite imagery with a photorecorder, while the remaining 22 receive imagery with a paper facsimile recorder. Both types of recorders are capable of displaying scanning radiometer data in an expanded mode which increases that data's useability. Our 37 units on FOFAX which receive APT, all have paper facsimile recorders. The major problems encountered are: 1) interference from ignition noise and from off frequency aircraft transmissions; 2) the frequent adjustments required to insure good copy is received

on paper facsimile recorders; 3) daily calibration is required of the photorecorders to receive quantitative data; and 4) changing line levels in transmissions to FOFAX and remoted installations which are in excess of the automatic adjustment range of the recorders."

(b-3) USN

"Shipboard Problems

1. Interference due to electromagnetic radiation (radar, radio, etc.) and ship's structure.
2. Fading of signal due to ship's movements in a seaway (roll and pitch, etc.).

Remote Problems

1. Timeliness of data.
2. Poor quality due to various causes such as losses in transmission lines, fading of microwave signals, tape recorder losses, etc."

(c) Question - "Please suggest improvements you would like to see with future satellite DR systems."

(c-1) NOAA

"A time mark on the imagery for gridding purposes is essential. Current practice leads to inaccuracies and requires the reception of the TBUS message which is not available to everyone. Another item overlooked is the production of master grids which can be used to reproduce grids for different aspect ratios."

(c-2) USAF

1. Increase the dynamic range of the transmitted signal output for the meteorologically useful IR data;
2. Improve signal to noise ratio of sensors along with increasing the power output of the transmitted signal;
3. Improve NEAT of infrared sensor to be less than  $1^{\circ}$  at  $200^{\circ}\text{K}$ ;
4. Remove foreshortening effect from SR data prior to its receipt at a ground station;

5. Include water vapor channels at 6.5 and 22 microns while keeping channels at 11 microns and in the visible range; all of this imagery should be 2 n. m. or better resolution for the low bandwidth transmission;
6. Continuous onboard calibration of all SR sensors;
7. Distinctive phase marks for each different transmitted signal;
8. Temperature contouring capability;
9. Detection of regions of aurora displays;
10. Low cost high quality display device (color and/or black and white) which will work with all modes of direct readout transmission;
11. Gray scale continuity throughout the scan line (visible);
12. Onboard rectification of sensor scan speed to adjust for earth's curvature;
13. In polar orbiting satellites, additional onboard data storage unit which would receive data from ground and "dump" data at a pre-selected time or in response to a select signal.

"These improvements suggested are for both polar orbiting and geostationary spacecraft; i. e., there should be a low bandwidth direct readout geostationary spacecraft as well as a low bandwidth polar orbiter which has the characteristics above.

"In addition, the Air Force suggests the following resolutions, location accuracy, and frequency of observations:

Areal Coverage	Resolution (n. m.) (over entire image area)	Location Accuracy (n. m.)	Timeliness and Frequency of Observation
Global (large scale)	2	10	22-0100Z + every 6 hours
Land Masses of Globe	.5	2	22-0100Z + every 3 hours
High Interest Areas	.25	1	00Z + every 30 minutes

"AWS units require imagery for a maximum area of 1500 nautical mile radius. Display of imagery data in the context of current support system is best used in a polar stereographic or mercator map projection on photographic film capable of 16/2 gray shades."

(c-3) USN

"Most significant-

1. Improvement of geometric resolution and contrast in satellite sensor/ground station system (includes improvement in quality of display).
2. More frequent observations.
3. Gridding improvements including accuracy and automatic gridding.
4. Extension of areas of geostationary satellite coverage.

"Significant-

1. More timely information (in the case of relayed information, remotes, FOFAX, etc.).
2. Extension of area of coverage including elimination of orbital gaps in the tropics.
3. Provision for digitizing signal and computer rectification to chart scale.
4. Correction of distortion due to limb darkening.
5. Provision for obtaining cloud heights.
6. Real time color enhancement to improve information content of display.

"Other-

1. Provision for larger display."

#### 2.2.4 Further Interpretation of Replies from U. S. Government Users

Because the U. S. Navy provided individual questionnaire replies, unlike NOAA and the USAF, who provided consolidated agency replies, it was possible to analyze the U. S. Navy replies in more detail. This provided the opportunity to rank suggestions for improvement quantitatively according to the number of times

each suggestion was made. This method is probably less valid than providing the responder with a suggested list of improvements to check off or grade in some manner.

The ranked suggestions are shown in Table 2-1.

Suggestion	No. of Similar Suggestions	% of Total Replies
Increase frequency of observations; many desire observations every 6 hours	22	43%
Improve quality of ground station recording and display equipment	18	37%
Increase resolution	15	31%
Provide for automatic gridding	13	27%
Promote training in image interpretation	8	17%
Remove image distortions	5	10%
Develop a method to determine cloud tops	5	10%
Include vertical temperature soundings	4	8%
Produce more accurate grids	4	8%
Make possible the distinction between snow and clouds	4	8%
Provide for ice detection through clouds	3	6%
Provide for color enhancement	2	4%
Increase side coverage to eliminate gap between swaths in Tropics	2	4%

TABLE 2-1  
Ranking of Suggested Improvements (U. S. Navy)

### 2.2.5 Replies from Domestic Private Sector Users

In this category of users, 56 questionnaires were distributed and 22 were returned. Of those returned, three were from educational institutions, nine were from broadcasters (mostly TV), and ten were from private forecasters. It is interesting that all three educational institutions had direct readout capability, while only two of the nine broadcasters and none of the ten private forecasters did.

The main reasons given for not having direct readout capability were cost, and, to a lesser degree, "quality." Virtually all these users operate in data rich areas where direct readout data has comparatively low value as an aid in weather analysis. As a direct aid in short term weather forecasting, the usefulness of cloud images is relatively short lived. The data are not available often enough; the timing of the data that are available is not optimum for meeting the short term forecasting needs. A noontime cloud picture appears to be of relatively little use for the evening or 11:00 p.m. TV weather programs, or to an early morning weather sensitive operation. Further, the TV weathercaster requires that the picture must be of good quality and in a form which can easily be displayed on TV.

The following excerpts, taken from the replies to the questionnaire from the domestic private sector, give flavor and support to the above:

"These photographs are probably the biggest aid that a meteorologist has with respect to attempting to fill the oceanic data gaps. Our work is highly keyed to real time data reception and definition of large scale environmental perturbations such as hurricanes, tropical storms, and intense cyclones." (Private forecaster using FOFAX and WEFAX service)

"Decreased time intervals between transmissions, improved gridding equipment and techniques, better dissemination of research information. More timely dissemination of information pertaining to operational status of satellites." (Broadcaster using DR)

"Primarily the time interval between data received or data transmitted. Twice daily would greatly enhance our operation. Ideally morning transmissions (ESSA VIII) followed by late afternoon DR as was the case when NOAA I was operative.

Secondly, an improvement in gridding overlays is surely needed."  
(Broadcaster using DR)

"Time!!! We must have these photos of the ocean cloud systems in our facility in time to be of use to us, not 18-24 hours later."  
(Private forecaster using FOFAX and WEFAX)

"The main limitation - as with nearly all operationally oriented projects - is the timeliness of the data as it relates to the required decision making times. The majority of time the data is simply not in time for inclusion in the decision making process. - Also cost." (Private forecaster using WEFAX)

"I am returning your questionnaire regarding satellite readout data. I feel I represent a large majority of the synoptic meteorologists in that we are totally unfamiliar with satellite data. In my opinion, NASA and the U. S. Weather Service, as usual, have done a horrible job in keeping us posted of the developments of satellite meteorology. I have never received any information on how to interpret data or where it is available to us. I do hear from manufacturers of facsimile equipment as to how we can receive certain types of information." (Broadcaster whose weather forecasters are widely heard, does not use DR, FOFAX, or WEFAX)

"One geostationary satellite over the East Coast would be more useful to the millions of taxpayers who live here than 1,000 satellites circling the globe. While the present satellite system is virtually useless in day to day forecasting, a geostationary satellite would have great immediate usefulness in visual storm and cloud system tracking. A network of geostationary satellites will offer the next breakthrough in forecasting by replacing the moisture analysis of the now 30 year old forecasting radiosonde network which is woefully inadequate!!!!!!" (Private forecaster using WEFAX)

These quoted replies from private domestic sector users represent both consensus views and more extreme views. Both types are included for completeness and, of course, in the latter case the reader should not conclude that the inclusion reflects approval, or the opinion on the part of the writer of this report



that the comments are justified.

#### 2.2.6 Foreign Users and Domestic Private Individuals

As it was impractical to query this category of direct readout meteorological satellite data users by means of the questionnaire (see Appendix 2-A), the primary sources of information were the replies to the annual NOAA APT Questionnaire, sent every October to active direct readout stations all over the world. NOAA lists 560 active direct readout stations as of October 1971. The NOAA APT Questionnaire does not specifically ask for suggested improvements in the Direct Readout System, although some of the answers to its question No. 6 "Comments or suggestions regarding our APT program," give information regarding desired improvements. The NOAA questionnaire is the only source of information from foreign users, and amateurs both domestic and foreign, used, and thus complements the survey. Most of the responses to question No. 6 suggested no changes and praised the direct readout program.

<u>Suggestion</u>	<u>Country</u>
Provide satellite passage at 9:00 a. m. local time	Tahiti, Hungary
Provide satellite passage at 10:00 a. m. local time	Italy
Provide satellite passage nearer to 12 Noon	Switzerland
Provide another satellite passage in the afternoon	Italy
Provide twice daily series of passes for coverage over Eastern Pacific	Canada
Overlap, or closer contact between contiguous swaths over equatorial regions	Mexico
Place geostationary satellite in position to provide extended coverage to west and east of Switzerland	Switzerland
Place geostationary satellite with DR and WEFAX capability over the Indian Ocean	Mauritius
Each new satellite should use frequency not used by other spacecraft still in operation	Germany

<u>Suggestion</u>	<u>Country</u>
Daytime DRIR over Arctic ice areas	Canada
Geostationary satellite at 40°W to facilitate interception in Africa and coverage of S. H.	South Africa
Improve transmission of TBUS messages to Angola	Angola
Furnish information on antenna aiming for ATS satellite reception	Chile
Increase image area of DRIR display	Hong Kong

A few of the foreign private (radio amateurs) users have expressed difficulty in obtaining information on satellite passage time. Other suggestions from amateurs worth mentioning include:

1. Use of synch. (as in Nimbus 3) on all future DR systems.
2. Publish satellite passage time in a weekly radio magazine of the country.
3. Publish a FORTRAN IV program which will yield azimuth elevation for a given station latitude-longitude using data now on teletype.
4. Use of standard television video to replace use of facsimile for reception of DR images.

### 2.3 Baseline for Defining an Unconstrained Spacecraft Direct Readout System

The user responses summarized below are used as a base line for determining an unconstrained spacecraft direct readout system which is discussed in Section 3.

#### 2.3.1 List of User Requirements and Recommendations for Improvement

- (a) Increase frequency of observations to at least every 6 hours.
- (b) Improve quality of ground station recording and display equipment.
- (c) Increase resolution to 2, 0.5, 0.25 n.m.

- (d) Provide for automatic gridding.
- (e) Remove image distortions.
- (f) Promote training in image interpretation. Produce a Direct Readout User's Guide aimed at the broadcast meteorologist.
- (g) Develop a method to determine cloud tops by temperature and/or brightness contouring.
- (h) Transmit vertical temperature soundings via WEFAX.
- (i) Improve gridding accuracy and facility.
- (j) Provide means to distinguish between snow cover and clouds.
- (k) Provide for ice and snow detection through clouds.
- (l) Provide color enhancement.
- (m) Increase side coverage to eliminate gaps between swaths in tropics.
- (n) Increase dynamic range of the transmitted signal output for the meteorologically useful IR data.
- (o) Improve signal to noise ratio of sensors, and the power output of transmitted signal.
- (p) Improve NEAT of IR sensors to be less than  $1^{\circ}$  at  $200^{\circ}\text{K}$ .
- (q) Include water vapor channel at 6.5 and 22  $\mu\text{m}$ .
- (r) Provide for continuous onboard calibration of all SR data.
- (s) Provide distinctive phase marks for each different transmitted signal.
- (t) Develop a low-cost, high quality display device which will work with all modes of DR transmission.
- (u) Provide capability of onboard data storage and "dump" at a pre-selected time.
- (v) Provide method of rectification to polar stereographic and mercator map projections.
- (w) Transmit time mark on imagery to facilitate gridding.
- (x) Use standard television video for reception of DR images.
- (y) Provide quicker transmission of satellite photos over facsimile lines.

### 2.3.2 Classification of Users

Before proceeding to the definition of an unconstrained direct readout system it is necessary to classify to some practical extent the users of direct readout data. (Refer to 2.1)

### 2.3.2.1 Differences Among Users

There is a wide diversity among the users. The specific areas of diversity included the following:

(a) Type of activity -

- (1) Operational - providing meteorological information in support of a great variety of operational activities and to the general public.
- (2) Research and development
- (3) Education and training
- (4) Hobby

(b) Detail and extent, in both area and time, of the meteorological services provided by operational meteorological activities. -

In general, the largest activities provide general analyses and forecasts for large areas for as long a time period as the state of the art permits. The smaller activities must provide services to specific users for specific purposes, frequently in great detail in space and time. The requirements of these two types of data while having much commonality also have marked differences as required by the differences in services provided.

(c) Facilities available -

There are differences in manpower, kinds and quantity of equipment, communication links, etc.

(d) Importance of the activity -

Such a determination is, of course, subjective and a matter of perspective. However, the view that operational activities are most important, that hobbies are least important, and that research and development and education and training are somewhere in between — this view would receive majority support.

(e) Public relations effect -

This is included because the correlation of the "importance" of a service or activity and the esteem in which it is held by the public and government, and, thus, its likelihood to attract favor and support, is considerably less than perfect.

- (f) Degree to which the activity is dependent upon direct readout data as compared with other sources or types of data -

This dependence may differ in an operational activity according to the geographical location or according to the general type of activity as in (a) above. It is assumed that only operational users (or those simulating operational activities for a purpose) require real-time data.

On one hand, there are the users who have broad responsibilities and major resources. There are relatively few in number. On the other hand there are the hundreds of amateurs who have high interest; but their responsibility is essentially limited to their own personal interests. A further consideration is the user's policy toward change and improvements. Two of the responding prime users having major meteorological responsibilities and apparently similar data needs express markedly different requirements for change and improvement. One of these taxes or exceeds the limits of what practically can be provided, while the other virtually calls for maintaining the status quo. Some of the apparent reasons for this difference in policy are the differences in the type of service they provide; whether or not alternate sources or means of acquiring data are available; the location of the operation; and historical differences in their philosophy of fund seeking.

#### 2.3.2.2 Preliminary Classification of Users

It is necessary for the purpose of this study to categorize these diverse users into as small a number of groups as possible in order to relate their common requirements to a practical design of spacecraft and ground facilities.

Practical design of the spacecraft immediately restricts the user groups to two broad classes because of the limited number of satellite to ground communication channels. These two user groups are:

- (1) Major activities with requirements for data which greatly exceed what is provided by the present systems.
- (2) Those users who are satisfied by the data now available and have a strong desire to be able to use their present ground equipment in the future.

The first group will require a communication link of much greater capacity than now used in direct readout. The second must continue to be provided by the

present communication link or something similar. Indeed, the U. S. Government has assured the international meteorological community that the present service will be continued. However, it will be assumed here that this is not a permanent commitment, and that the minimum service can be upgraded if sufficient notice (3 years) is given, and a convincing case for the upgrading is made.

#### 2. 3. 2. 3 Small Stations with Important Responsibilities

These two classes are not enough, however, there is a third important category of user, who because of the nature of his mission and limitations to physical facilities and manpower, cannot use the high capacity communication system required by group 1 above, but who nevertheless, due to the nature and location of his operational mission, has a strong requirement for high quality, dependable direct readout data; requirements which are not satisfied by present systems. This type of user is commonly required to make detailed, short-range, local area forecasts, as well as large area forecasts and route forecast for weather-sensitive operations of great importance in areas where there is no practical alternative to the use of direct readout data. The flavor of the requirements and problems of this type of user is shown by the following excerpts from the replies to the user questionnaires.

"Most significant limitations to the use of data are the level of resolution of the picture in the present receiving system and the once-a-day coverage with ESSA VIII. At low latitudes the area of interest is often between passes resulting in less than daily coverage."

"Most significant improvements that could be made in future systems are improvement of picture resolution to photographic quality and more frequent coverage."

"Would like to have four passes or more per day starting about one hour after local sunrise, and then every six hours. Improved resolution. More frequent and world wide availability of processed pictures from the geostationary satellites would reduce local workload and training requirements."

" The basic philosophy is that the man at the receiving end at the small station is the one who needs the most timely piece of information and in the smallest detail, because he's making the small-scale forecast. He's producing forecasts that are in the time frame of 6 to 8 hours; in order to produce the forecast of this nature, he has to have fine resolution imagery to see the detail that he needs to make his forecast. He is interested in an area of about 500 miles radius."

" Present resolution does not allow for determination of cloud types. Lack of cloud height data and structure in the vertical. Lack of information regarding precipitation type and intensity. Present resolution does not allow for accurate determination of cloud cover in -- [operational] -- areas where visual contact with the ground is required. Timing of the pass is too late in the day for maximum flexibility in planning and utilization."

" ESSA Eight data over the Antarctic continent is of very little value as all features are masked by high reflectivity, but is used to depict upper air data along the 170°E flight-track from McMurdo to New Zealand and adjacent ocean areas. It is the major satellite used in locating jets, cyclones, fronts and ridges and for steering surface systems over ocean areas. Another disadvantage is that its orbit does not cover South Pole Station. Nimbus IV, due to its lower orbital altitude, shows cloud patterns and shadows readily over ice and snow covered areas. It is an invaluable source of data for depicting synoptic scale weather patterns over the continent and very closely approaches the meso scale over the adjacent ocean areas."

" The availability of DRIR data from Nimbus IV would greatly enhance its usefulness by filling in large scale moisture and temperature distribution: quite frequently DR satellite data is the only source of data for use in forecasting weather for remote open field landings."

" The resolution is not sufficient for close evaluation of cloud cover prior to --[operations]--. Cloud heights cannot be obtained other than by inference from cloud types. The resolution frequently

makes it difficult or impossible to properly identify cloud types. There is no infrared transmission at present. "

"This -- activity -- presently experiences two major limitations with present DR systems: lack of dependability of new satellites and limited frequency of data. --- With rapidly developing severe environmental systems transiting this area, the necessity for frequent and detailed information is obvious. --- Past experience from prior assignments reveals that the present quality of many circuits and the facsimile equipment utilized drastically degrades satellite products received. Also, present relay systems appear to lack either the expansion or refinement capability to adequately address future user requirements for quantity and/or quality. From an operational viewpoint, the local user is more likely to have increased interests in frequent, timely and high quality information to support short fuze environmentally sensitive -- [operations] -- than for degraded large scale products. "

#### 2.3.2.4 Radio Frequency Interference

Also included in the replies to the questionnaire were comments about the problems of local radio interference. The U. S. Naval Electronics Laboratory report (Leonard 1968) dealing with problems of shipboard reception of satellite signals states, "The problems of RF interference (RFI) and antenna size seem to be related: RFI is related to side lobe level; side lobe suppression is related to gain; and gain is related to antenna size. The only solution to these problems is an increase in satellite power. A modest increase might allow use of a different antenna configuration and hence a smaller size; however, only a substantial increase of power will totally eliminate the RFI problem. Fortunately, current data rates and RFI incidence rates are low enough that the majority of pictures are useable despite some RFI degradation." And the report goes on to state, "If the satellite power were increased by as little as 6 db, a favorable signal-to-noise ratio might be maintained at a substantial savings to the Navy both in cost and complexity. "



### 2.3.3 User Types - Characteristics and Data Requirements

For the purposes of defining an unconstrained system, the users of direct readout meteorological data are divided into three groups. Characteristics of each group are listed as to purpose, type of operation, communications, data analysis, manpower, facilities, and the requirements for direct readout meteorological satellite data:

#### 2.3.3.1 Large Station

Characteristics:

- (1) Responsible for services for a relatively large area.
- (2) Frequently supports smaller stations.
- (3) Has personnel and equipment to perform moderate to extensive analysis of the data.
- (4) Largest of this type station wants data primarily in quantitative or parametric form.
- (5) Is more likely to be handicapped by lack of observed data than by the capability to handle data.
- (6) Can accommodate communications facilities to receive and retransmit large volumes of data.
- (7) Forecast responsibilities are for large areas, for longer periods of time, and not in any great detail for specific areas.
- (8) Data requirements and needed improvements are those listed below:

Data requirements:

- (a) Increase frequency of observations to at least every 6 hours.
- (b) Improved quality of ground station recording and display equipment.
- (c) Increase resolution to 2, 0.5, 0.25 n. m.
- (d) Automatic gridding.
- (e) Removal of image distortions.
- (f) Further training in image interpretation. A Direct Readout

User's Guide aimed at the broadcast meteorologist is needed.

#### 2.3.3.2 Small Stations with Large Operational Forecasting Responsibilities

Direct readout satellite imagery is used in numerous ways by small stations with operational forecastings responsibilities. The two most important ways are in correcting and updating the synoptic analysis which frequently is transmitted from a larger station, and in direct use in making detailed short range forecasts for time intervals up to a few hours. For analysis update and correction, the requirement is for broader coverage with lesser requirement for high resolution. For short term detailed forecasting the requirement is for high resolution over specific areas and usually, a diminished requirement for broad area coverage. Because the smaller the scale of a meteorological feature, the shorter its identifiable lifetime, the usefulness of high resolution cloud images in short-term forecasting degrades quite rapidly with time.

In a similar vein the forecaster requirements for high resolution cloud images is greatest for the specific area for which the short term forecast is made and diminishes with distance away from that area. It would be highly desirable that the ground station for this class of user have the high resolution data stored in an electronic storage device, and have the ability, within the resolution limits of the display device, to display large areas at relatively low resolution and smaller areas at relatively high resolution.

##### 2.3.3.2.1 Characteristics

Among the general characteristics of this type of station are the following:

- (1) Usually responsible for much smaller areas than the large stations, but the forecast responsibilities are much more specific. The areas for which detailed forecast are made may change and, indeed, the station may be mobile.
- (2) Such stations are manpower limited and equipment limited. They are considered responsive to justified requirements for upgrading equipment, but subject to definite space, fiscal, and performance limitations.

- (3) Communications capability is limited.
- (4) Capability for qualitative and quantitative analysis is limited. Area analyses are usually received from large stations, and then upgraded and updated for specific areas of interest by means of local, more timely data.
- (5) Forecasts are frequently for important weather sensitive operations which require short range detailed weather forecasts for which real time, good quality, timely direct readout data is needed.
- (6) Data requirements are characterized by:
  - (a) Reliability - assurance that good data will be received, even under conditions that are at times degraded.
  - (b) Timeliness - usefulness of data for short range detailed forecasts is short lived. Data at frequent intervals is highly desirable.
  - (c) Better spatial resolution - improvement in resolution is needed for detailed short range forecasts.
  - (d) Better gridding and removal of image distortion - methods are needed to make efficient and timely use of the data.
  - (e) An increase in the number of types of data received if compatible with the above requirements, particularly if it can be automatically analyzed and displayed with the limited facilities of this type of station. Heights of clouds or related information is of high priority.

#### 2.3.3.3 Other Small Stations

A strong and practical requirement of this type of station is the capability to continue to receive direct readout data from future satellites with basically the same type of ground equipment now used. It is noted that the Administrator of NOAA (White, 1971) has assured the international meteorological community that the APT VHF service will be continued indefinitely, although ultimately only scanning radiometers will be used to generate images for the APT service.

## 2.4 Comment on User Requirements

The user requirements for direct readout data as developed in this section represent a major increase in types and sophistication over that which is currently provided. This fact combined with a commitment to continue to provide the present type of data to many users and the need to provide better data to another important class of small users makes the problem of planning a system of reasonable size and cost which will satisfy these requirements a most difficult task.

It should be noted, also, that in the months subsequent to the receipt of the completed user questionnaires the NOAA 2 satellite is in operation and improved facsimile service has been instituted. This improved service has to a degree alleviated some of the problems stated by the users.

### 3. ELEMENTS OF THE UNCONSTRAINED SYSTEM AND TRADE-OFF ANALYSIS

The survey of the users established an inventory of improvements desired for the conduct of their meteorological activities, without regard to the feasibility of incorporating these features into the satellite/ground system of direct readout. An "unconstrained system" will be developed which satisfies these requirements within the realm of feasibility. Trade-off analysis and subsequent evaluation will define a "recommended system" based on the realm of practicality.

#### 3.1 Summary Restatement of Priority User Requirements

Table 3.1 lists the user requirements which may be satisfied within the satellite systems. The items in the table were examined with respect to their technical feasibility and their interaction within the spacecraft system. These assumptions provided the general ground rules for the investigation:

- 1) There are no a priori restrictions on the number or size of the spacecraft in the system.
- 2) Low altitude and geostationary satellites may be considered.
- 3) Communication links will be constrained to standard frequency allocation limits.
- 4) The spacecraft will perform global data gathering for central processing in addition to the direct readout function.
- 5) Direct readout stations may be located anywhere on the earth, necessitating global coverage.
- 6) Direct Readout ground stations will be either:
  - a) Class 1 regional distribution centers
  - b) Class 2 stations
  - c) Class 3 VHF stations

Other factors must be considered in configuring a system. The format of the transmitted data should, when possible, conform to the facsimile standards of the World Meteorological Organization (WMO). As new systems are developed, criteria of resolution and system bandwidth require variations on these standards. Line rates of 120 lines per minute (lpm), the WMO standard, or rates integrally related to 120 lpm, can be provided while satisfying other system constraints.

The large number of stations with limited resources which use the existing data format impose the requirement of maintaining the transmission of data in a format compatible with existing equipment while implementing new techniques. The gradual phase-out of the older techniques can then be accomplished with minimum impact on the users. In this context, the incorporation of a correction to remove image distortion resulting from earth/scan geometry and revision of synchronization signals to identify data can be accomplished at once in the VHF data while increased resolution and digital transmission may be introduced concurrently with the transmission of the analog data.

In a system, upon which essentially no constraints have been imposed, processing in the spacecraft would include (1) gridding with a real time attitude input, (2) continuous calibration correction using space scan, housing scan and sensor temperature, (3) a GMT reference, and (4) temperature contouring in the visible data.

Certain ancillary data is of importance to the real time users. Proper tracking of the spacecraft and application of correct gridding information require timely receipt of ephemeris and attitude data. Digital and voice transmission of this information at regular intervals via the SMS WEFAX net fully satisfies this requirement equatorward of  $40^{\circ}$  latitude, and partially to  $60^{\circ}$  latitude, assuming 4 satellites globally distributed.

Table 3-1 summarizes the items of user requirements which apply to the spacecraft in the meteorological satellite system. In general, the user requiring 6 hours between observations and 2 n. m. resolution is the regional forecaster; whereas, the user requiring half hourly observations and 0.25 n. m. resolution is the local forecaster with a smaller area of specific interest. This represents a dichotomy between requirement and resources. Reception of the latter data by the smaller stations requires a greater investment of resources which is usually not available. However, the unconstrained system will address these requirements.

More channels are requested for additional spectral data and other types of sensors which will provide vertical sounder data, near IR data for land mass identification, and water vapor data. (Appendix C describes the sensors now implemented or in the development and planning programs of NASA/NOAA.)

These characteristics and the other requirements are discussed in the subsequent pages of this section with regard to feasibility. Note that the requirement to eliminate gaps in coverage in the tropics is not included since present ITOS

TABLE 3-1

Summary of User Requirements Affecting Satellites

No.	Comment
1 Period between observations of local area	6 hours      3 hours      1/2 hour
22 Sensors Vertical Sounder Radiometer Resolution Signal-to-Noise Spectra Visible      0.5 - 0.7 $\mu\text{m}$ Near IR      0.7 - 1.0 $\mu\text{m}$ Water Vapor      6.5 & 22.0 $\mu\text{m}$ IR      10.5 - 12.5 $\mu\text{m}$ Coverage	  2 n.m.      0.5 n.m.      0.25 n.m. 1° at 200°K  Eliminate gaps in tropics (Note: There are no gaps in the present ITOS system).
3 Increase received signal power	
4 Ice/Snow Detection Discrimination Through Clouds	
5 Mapping Improvements Correct scan induced geometric distortions. Rectify into standard map projections	
6 Map Gridding Automatic Improve accuracy	
7 Cloud Top Temperature Determination	
8 Distinctive Data Identifier Markers or Synchronization Signals	
9 Time Reference in Data	
10 Dynamic Gain Control	
11 Continuous Onboard Calibration	
12 Data Storage and Dump	Desired on direct readout to provide coverage of tropics for mid-latitude users.
13 Regular Relay of Ephemeris Data	

systems have no gaps in the tropics.

### 3.2 Requirements Trade-off Analyses

The trade-off analyses for each subject in Table 3-1 are evaluated independently. The trade-offs address technical feasibility and the interaction of any changes in parameters with other spacecraft and ground systems.

#### 3.2.1 Period Between Observations

The nature of the satellite operations is such that the period between observations is primarily determined by orbital characteristics. The minimum period between observations requires certain orbital characteristics and numbers of spacecraft. It is then more efficient to transmit all the data of a certain characteristic rather than attempt to select data for specific areas.

The requirements for time intervals between observations and the coverage which requires these intervals are:

<u>Period</u>	<u>Coverage</u>
6 hours	Large Areas, Generalized forecasts
3 hours	Local Areas, More specific forecasts
1/2 hour	High Interest Areas, Detailed forecasts

The coverage must be global and local data must be available to stations located anywhere.

##### 3.2.1.1 Sun-Synchronous Orbit

The sun-synchronous orbit, while having the important advantage of minimizing the sun angle variation on both the spacecraft and at a given point on the subtrack, has certain inherent coverage restrictions. The inclination (retrograde) must increase with increasing altitude in such a way that the constraining relationship between inclination and altitude, as dictated by the oblateness of the earth, is satisfied. Furthermore, increasing altitude results in a longer orbital period and, hence, a greater subtrack separation for adjacent orbits. On the other hand, the coverage possible, within the limits of any given local zenith angle, for any one orbit, increases with increasing altitude. The generally accepted upper limit for



the local zenith angle, beyond which little information is available from the data, is  $65^{\circ}$ . If this limit is applied, the constraining relationships are properly depicted in Figure 3-1. The maximum altitude for which coverage of the poles is just possible is 2000 n. m. The minimum altitude for which coverage swaths on adjacent orbits of the same satellite will just be contiguous is 530 nautical miles. This then gives the gross limits within which the alternatives must lie.

The frequency of readouts for any particular station can be related to the number of spacecraft in the system. A single spacecraft, in a 907 n. m., 2 hour orbit, will provide direct readout over a specific ground track every 12 hours. If a two spacecraft system is employed, the frequency can be increased to 4 times per day or every 6 hours. In this case, the orbits of the two spacecraft would be arranged with a  $90^{\circ}$  longitude separation between their respective ascending nodes. Global coverage would then be accomplished every 3 orbits or every 6 hours, with both spacecraft having coincident suborbital tracks.

The minimum number of spacecraft that will provide global coverage every 3 hours is four at altitudes between 1300 n. m. and 2000 n. m. (See Figure 3-2). Recall that 2000 n. m. is the upper limit from polar coverage considerations. The spacecraft's orbits would be oriented with ascending nodes  $45^{\circ}$  apart, with global coverage being obtained in one orbital period or 2.8 hours. However, the time between direct readouts to a particular ground station is a function of its latitude. This is due to the geometry of the sun-synchronous orbit with the prescribed orbit inclination. It is this geometry which causes a direct readout to a ground station at mid-latitudes to be periodically more than three hours if only three satellites are used. Thus, the minimum number of spacecraft for coverage every 3 hours would be four, at an altitude greater than 1300 n. m.

It should be noted that these multi-satellite systems discussed above require phased, controlled orbits to obtain the coverages stated. An onboard Orbit Adjust Subsystem is required on each spacecraft in these multi-satellite systems. Furthermore, orbit altitudes that produce an integral number of orbits per day and, hence, a daily repetitive ground track, have many inherent advantages. For the centrally processed data, the scheduling problem for transmission of outputs is greatly reduced. For the direct readout stations, not only is data obtained at the same time each day, but gridding is greatly facilitated since the sub-orbital tracks are always the same for any particular direct readout system.

Thus, the optimum choices for the sun-synchronous orbit are shown in the

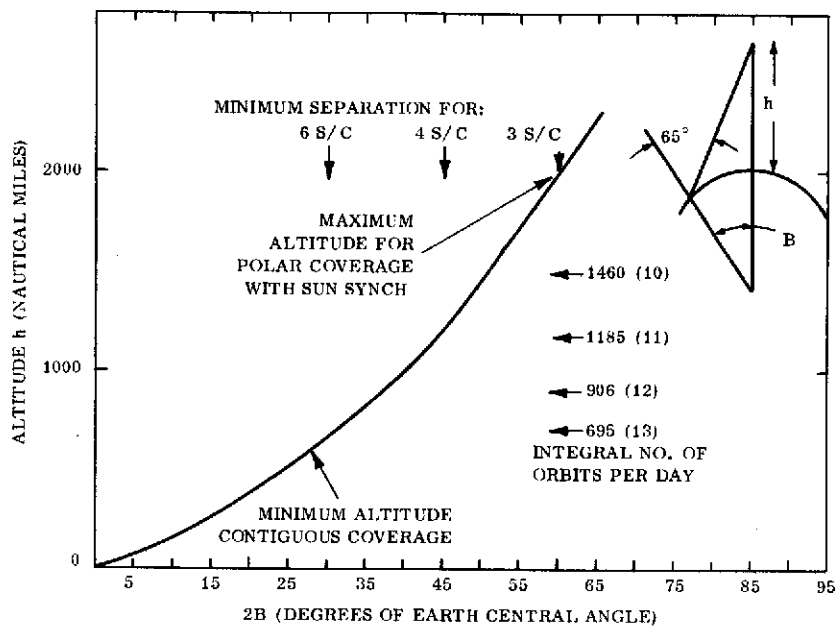

Figure 3-1 Altitude vs. Earth Central Angle for Coverage to Local Zenith Angle of  $65^\circ$

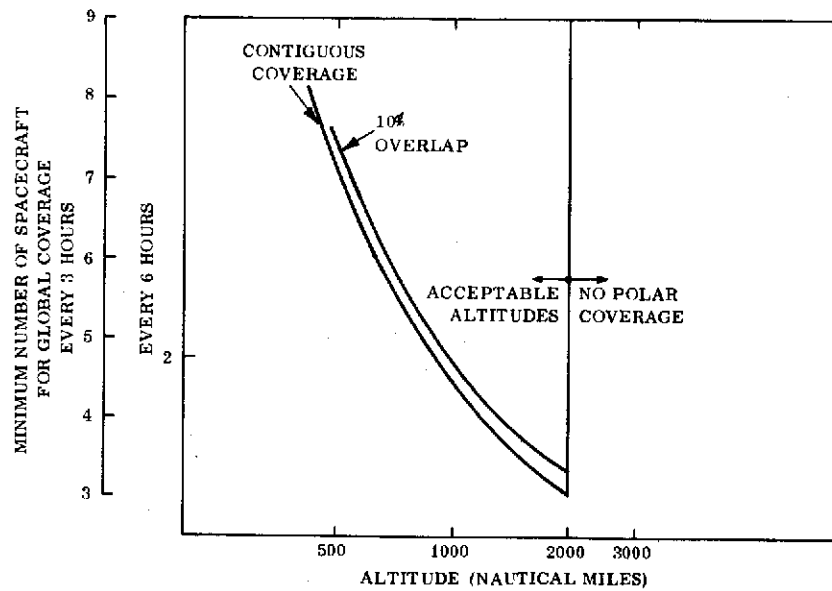

Figure 3-2 Minimum Number of Spacecraft and Altitude for Global Coverage Every 3 to 6 Hours in a Sun-Synchronous Orbit

following table.

TABLE 3-2

Sun-Synchronous Orbit Spacecraft Systems

<u>Required Frequency</u>	<u>Number of Spacecraft</u>	<u>Longitudinal Separation of Orbits</u>	<u>Altitude</u>	<u>Frequency Obtained</u>
Every 6 hrs.	2	90°	906 n.m.	Every 6 hrs.
Every 3 hrs.	4	50.8°	1460 n.m.	Every 2.4 hrs.
Every 30 min.	(Prohibitive Number of Spacecraft)			

3.2.1.2 True Polar Orbit

The true polar orbit achieves some coverage advantages over the sun-synchronous orbit while presenting much more difficult spacecraft and sensor design problems. (It has the additional advantage of more contact with the two existing Command and Data Acquisition Stations at Wallops Island, Virginia, and Gilmore Creek, Alaska.)

Specifically: (1) the power system must have a 2-axis orientable solar array, (2) the thermal design must accommodate all sun angles, and (3) passive coolers for radiometer detectors cannot be used.

On the other hand, more efficient coverage is obtained, and there is no specific upper limit on the altitude for global coverage since the inclination is 90° for all altitudes. These two factors combine to permit a three spacecraft system at 2000 n.m. to satisfy all the coverage requirements and provide global coverage every 2.8 hours. Polar orbit systems are summarized in the following table.

TABLE 3-3

Polar Orbit Spacecraft Systems

<u>Required Frequency</u>	<u>Number of Spacecraft</u>	<u>Ascending Node Separation</u>	<u>Altitude</u>	<u>Frequency Obtained</u>
Every 6 hrs.	2	90°	907 n.m.	Every 6 hrs.
Every 3 hrs.	3	60°	2000 n.m.	Every 2.8 hrs.
Every 30 min.	(Prohibitive Number of Spacecraft)			

While the 200 n.m. orbit requires only three satellites, it does result in readouts occurring at different times each day.

#### 3.2.1.3 Geostationary Orbit

The geostationary orbit has the advantage of providing more frequent coverage, but cannot provide global coverage. Observations can only be made up to a maximum latitude of  $57^{\circ}$ , when the maximum local zenith angle is kept at  $65^{\circ}$ . Furthermore, four spacecraft are required to provide complete equatorial observations. See Figures 3-3 and 3-4.

The geostationary orbit provides the most reasonable alternative for providing the data on high interest areas: every 30 minutes. However, the sensor and communications link problems are severe. This factor will be considered in succeeding sections.

#### 3.2.1.4 Summary

Table 3-4 summarizes the conclusions for a feasible satellite system which will satisfy the requirements for time intervals between readouts.

### 3.2.2 Sensors

The current ITOS systems transmit real-time data from two spectral regions, infrared and visible, and produce vertical temperature sounding data for use at major central processing facilities. Plans are being evaluated to include raw sounder data as a real-time transmission, and the TIROS-N Phase A study describes an Advanced Very High Resolution Radiometer (AVHRR) which detects radiance in four spectral regions; VIS (0.5-0.7  $\mu\text{m}$ ), near infrared (0.8-1.1  $\mu\text{m}$ ), water vapor (6.5-7.0  $\mu\text{m}$ ), far IR (10.5-12  $\mu\text{m}$ ), and a vertical sounder.

#### 3.2.2.1 Vertical Sounder

The system for establishing an atmospheric vertical temperature profile is still being explored, evaluated, and developed. Hence, this report will not devote any attention to the spectral or field-of-view characteristics of the necessary instrument. The NOAA-2 instrument generates radiance data at a rate of 256 bits per second. Projected bit rates of improved sensors go as high as four kilobits

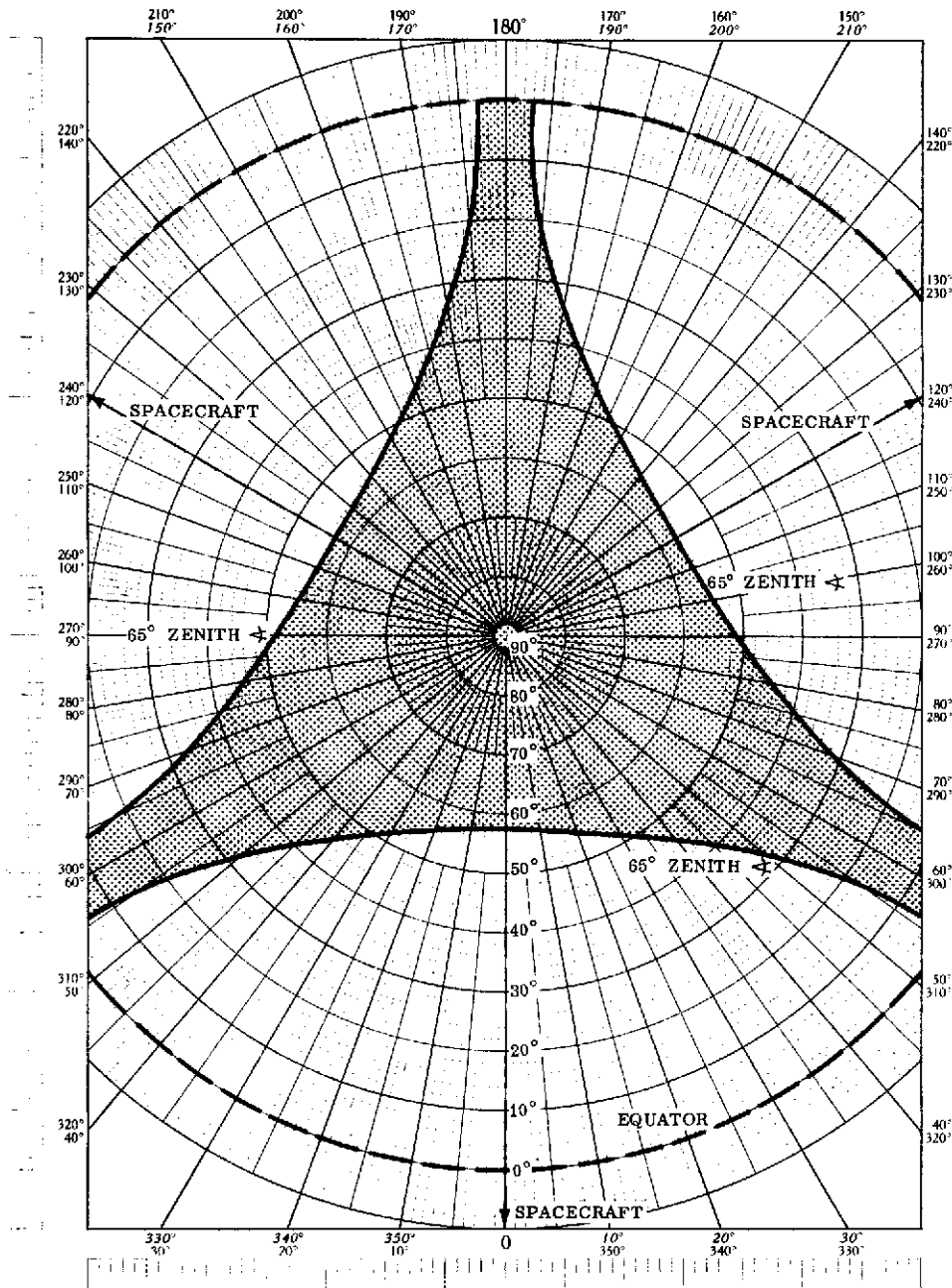

Figure 3-3 Coverage from Three Geostationary Spacecraft over Equator, Edge-to-Center Resolution = 2.8 n.m. at 65° Zenith Angle.

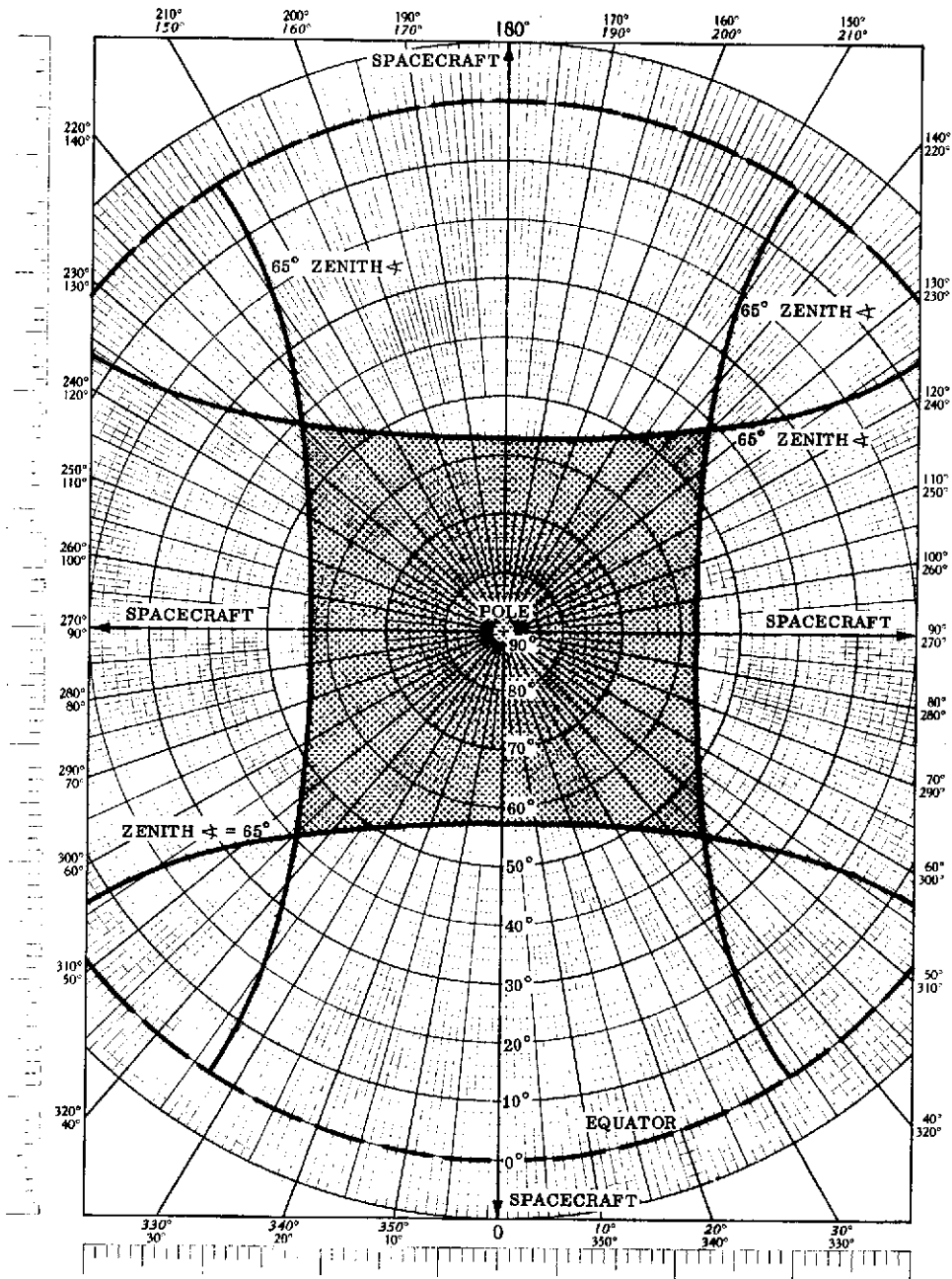

Figure 3-4 Coverage from Four Spacecraft over Equator, Edge-to-Center Resolution -2.8 n.m. at 65°.

TABLE 3-4

Feasible Satellite System to Satisfy Observation Frequency

Coverage	Requested Period	Period Provided	Number of Satellites	
			Geostationary	Low Altitude Sun-Synchronous
Large Areas	6 hrs.	6.0 hrs.		2 at 906 n.m.
Local-Regional Areas	3 hrs.	2.4 hrs.		4 at 1460 n.m.
High Interest Areas	1/2 hr.	1/2 hr.	4	



per second. To use the profile data to generate a vertical temperature profile requires an extensive computer facility not considered within the resources of the direct readout user within the context of this study. Optimistically, the research in this field will ultimately produce a mathematical relationship which will be amenable to manipulation by a medium-sized mini-computer. This size computer will be within the resources of the direct user. The data may first be transmitted on ITOS as a full time signal on the ITOS beacon transmitter at 136.77 MHz. But for the purposes of this study, vertical sounder data will be considered as part of the system available to the real-time user in the digital transmission of radiometric data. Initial sounder data rates will be about one kilobit per second (512 bi-phase modulated) with an eventual rate near four kilobits per second.

Even if the generation of a vertical temperature profile should prove to be beyond the capability of a direct readout user, radiance values in certain sounder channels will permit determination of parameters such as stratospheric temperatures, surface temperatures, and total water vapor content.

#### 3.2.2.2. Radiometer

TABLE 3-5

Requirements for Radiometer Data

<u>Data Type</u>	<u>Resolution</u>
Global	2.0 n.m.
Local	0.5 n.m.
High Interest Areas	0.25 n.m.
NEAT of IR Channels = 1°K	
<u>Channels Required</u>	<u>Δ λ (μ)</u>
Visible	0.5 - 0.7 μm
Near IR	0.8 - 1.1 μm
Far IR Window	10.5 - 12.5 μm
Water Vapor	6.5 - 7.0 μm
Water Vapor	17.8 - 21.8 μm

In a direct readout system, the parameters of resolution, signal-to-noise ratio, and number of channels can be examined in light of their impact on two basic subsystems: the sensor design and the communications link capability. To preserve the unconstrained nature of the investigation, the two areas will be discussed independently.

#### 3.2.2.2.1 Low Altitude Orbit Sensor

The basic video sensor being planned for the next generation of operational meteorological satellites is the Advanced Very High Resolution Radiometer; a four channel scanning radiometer designed to operate at an altitude of 907 n.m., with a nadir resolution of 0.5 n.m. in three channels and 2.0 n.m. in the water vapor channel (6.5 - 7.0  $\mu\text{m}$ ). This planned improvement on the basic sensor used by the future direct readout system covers some of the items listed in 2.3.1, while other items on the list would require a further extension of the AVHRR.

Specifically, items not covered are:

- a) Resolution of 0.25 n.m. (and 0.5 n.m. in the water vapor channel)
- b) Remove image distortions
- c) Include a water vapor channel at 22  $\mu\text{m}$ .

Before the implications of the above items are discussed, a clarification of terms is in order. It has been assumed that a resolution of 0.5 n.m. means that the subpoint resolution in the displayed video is 0.5 n.m. This is the accepted definition when applied to earth observation sensors. If rectification of data is desired, that is, removal of the effects of the earth's curvature such that the scale of the displayed data is constant over the entire picture, it can be accomplished in two ways: (1) by transmitting the data taken at a constant sensor Instantaneous Field of View (IFOV) with the low resolution (edge) samples repeated an appropriate number of times, or (2) by transmitting constant resolution data. The latter is a much more desirable and efficient method, since the communications link capability is the same in either case, but the average resolution of the picture in the latter case is significantly better.

Using the limit of a local zenith angle of  $65^\circ$ , Figure 3-5 shows the variation of the nadir angle and the subtended earth central angle as functions of altitude. Constant resolution is merely constant angular increments of earth central angle across the scan.

There are two basic ways to accomplish the acquisition of constant resolution video. One way would be to utilize a sensor whose scan is driven at approximately a sinusoidal angular rate with a corresponding variation in the sensor IFOV. Such a sensor design is moderately difficult to accomplish in practice. The other method, digital averaging of data taken from a scanning sensor with a fixed IFOV and a constant scan rate is also difficult. In the latter case, both along scan averaging and line-to-line averaging must be accomplished at a varying rate dependent on the position in the scan. The averaging process must be done with integral numbers of samples, but the resolution is varying continuously at two different rates in the two orthogonal directions. Thus, a very complicated averaging process is required which, at best, merely approximates constant resolution while putting the design burden of a higher resolution on the radiometer.

Figures 3-5 through 3-8 show the viewing parameters for both constant resolution and fixed IFOV. It was assumed that all useful data out to  $Z = 65^\circ$  would be transmitted, and the data would not be limited to that which would be contiguous with the adjacent orbit.

Consider now a scanning radiometer with a fixed IFOV. To limit the number of variables, the 907 n.m. altitude will be used in the following discussion.

The problem of sensor design to achieve the same resolution and S/N ratio differs for each of the five channels. The water vapor channels are the most difficult, since the spectral bandwidth is relatively narrow, and the maximum radiance to be observed is approximately that of a  $280^\circ\text{K}$  blackbody. The next most restrictive design is caused by the IR window channel, with the visible and near IR channels presenting the least restrictive design problem.

The AVHRR being procured for TIROS-N will have the following basic parameters for the IR window channel:

Dc	- diameter of primary optics	= 20 cm
$\theta$	- IFOV	= $.55 \times 10^{-3}$ rad
F	- F/number	= .89
$\alpha$	- optical efficiency	$\approx .35$
D*	- HgCdTe Detectivity ( $100^\circ\text{K}$ ) (10.5-12.5 $\mu$ )	= $1.6 \times 10^{10}$ cm Hz <sup>1/2</sup> watt <sup>-1</sup>
NEAT	- Noise Equivalent Change in Temperature	= $1^\circ\text{K}$ at $185^\circ\text{K}$

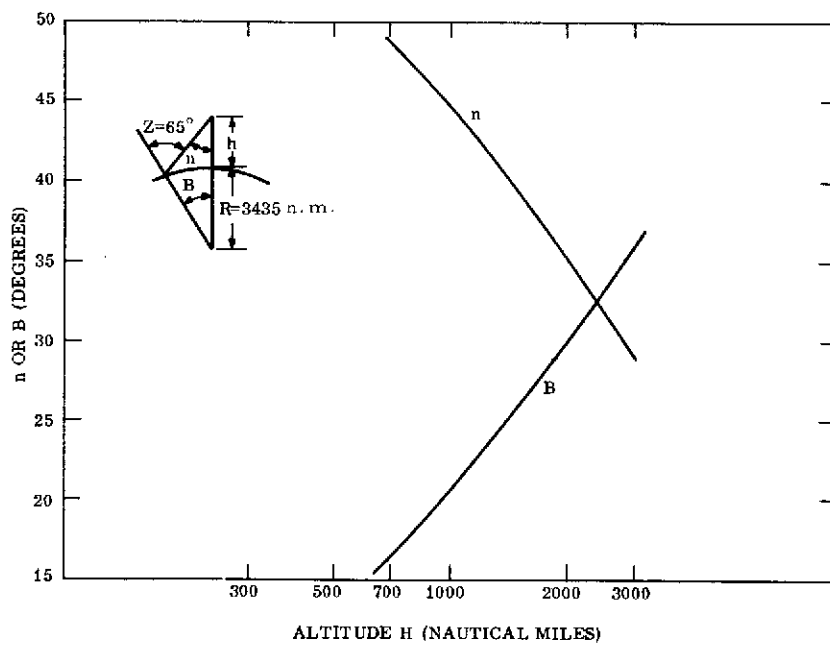

Figure 3-5 Earth Central Angle and Nadir Angle vs. Spacecraft Altitude for a Zenith Angle of  $65^\circ$ .

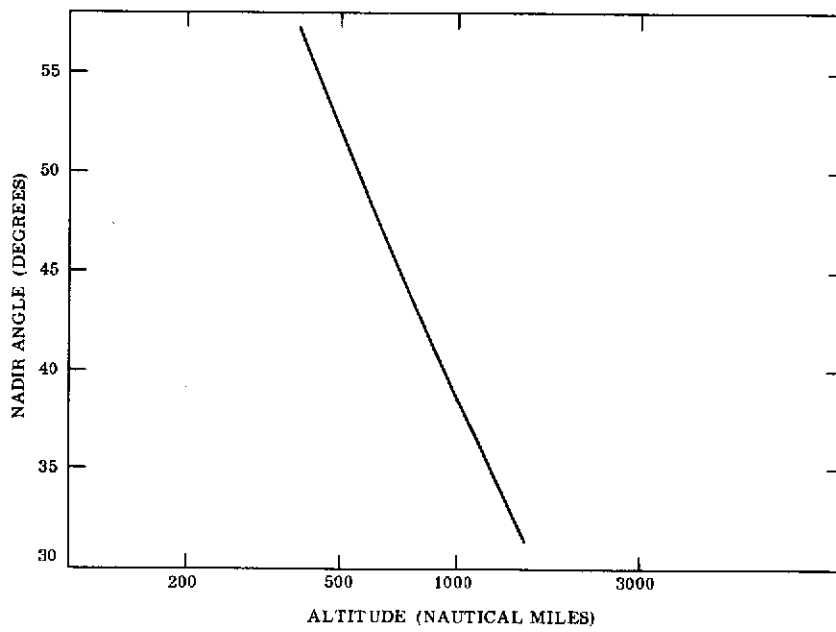

Figure 3-6 Nadir Angle for Contiguous Coverage for a Single Satellite in a Sun-Synchronous Orbit.

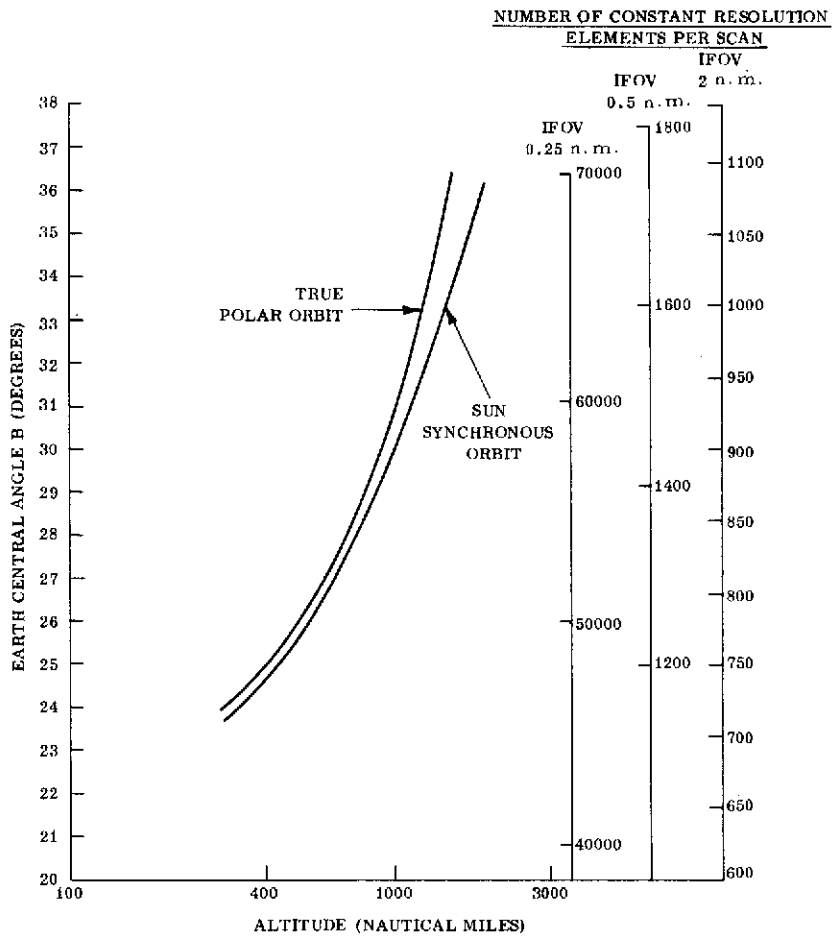
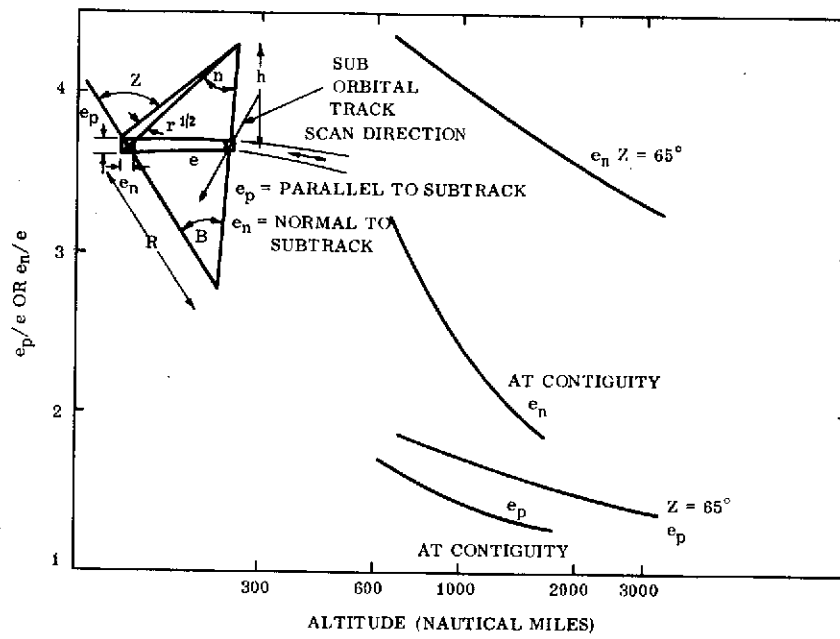

Figure 3-7 Earth Central Angle Required for Contiguous Coverage at Equator by a Single Satellite.



$$\frac{e_p}{e} = \frac{\sin B}{\sin n (\cos B + \sin B \cot n - 1)}$$

$$\frac{e_n}{e} = \frac{\sin B}{\sin n (\cos B + \sin B \cot n - 1) \cos (Z)}$$

Figure 3-8 Edge to Center Resolution Ratios -  $e_p$  and  $e_n$ , Sun-Synchronous Orbits.

The above  $D^*$  value represents a state-of-the-art cost tradeoff in HgCdTe detectors operated at  $100^\circ\text{K}$ . At 907 n.m. altitude, an IFOV of  $.275 \times 10^{-3}$  rad is required to produce a resolution of .25 n.m. This would require a corresponding increase in the diameter of primary optics ( $D_c$ ) to  $4 \times 20 = 80$  cm, an unacceptable value. (The  $F/1.89$  system is the fastest that can be reliably designed.)

However, current deliveries of HgCdTe detectors are being made at a  $D^*$  of  $>2.0 \times 10^{10}$   $\text{cm Hz}^{1/2} \text{ watt}^{-1}$ , and a reasonable forecast in the state-of-the-art would be  $3.0 \times 10^{10}$  in 2 years. This would allow a reduction in  $D_c$  to 42 cm. Furthermore, the AVHRR scanning system uses a single mirror scanned through a full  $2\pi$  radians such that the duty cycle is less than 30%. A double sided, harpoon type scanning mirror would increase the effective duty cycle by 1/2 and reduce  $D_c$  to 30 cm - a very realistic value. The 0.25 n.m. resolution for the two visible channels is more easily obtainable.

The  $6.7 \mu\text{m}$  water vapor channel presents a more difficult problem. The AVHRR will be designed to achieve 2.0 n.m. resolution in this channel, such that an argument similar to the one presented above would allow a subpoint resolution of 1 n.m. to be achieved with a 30 cm entrance optics and a harpoon scanning mirror. But because a 2.0 n.m. channel is employed in what is a radiometer basically designed for 0.5 n.m. resolution, each line scan is  $3/4$  overscanned. If this data is subsequently digitally averaged, a S/N increase of 10 db in practice, 12 db in theory, is achievable. This means the Noise Equivalent Radiance could be increased by a factor of 3 or the resolution decreased by a factor of .577, so that .58 n.m. is an achievable resolution in the near future.

The radiometry for the  $19.8 \mu\text{m}$  water vapor channel is very similar to that for the  $6.7 \mu\text{m}$  channel. The addition of a  $19.8 \mu\text{m}$  channel to the AVHRR at a resolution of 2.0 n.m. is very realistic. The housing would have to be modified to provide sufficient room for the additional secondary optics that would be required. The collector diameter and focal length are adequate for a 2.0 n.m. resolution when used with a HgCdTe detector ( $100^\circ\text{K}$ ) with a  $D^*$  of  $.9 \times 10^{10}$   $\text{watt}^{-1} \text{ Hz}^{1/2} \text{ cm}$ .

#### 3.2.2.2.2 Geostationary Altitude Sensor

The Synchronous Meteorological Spacecraft (SMS) to be launched in FY 1974 will have the Visible and Infrared Spin Scan Imaging Radiometer as its primary sensor. The resolution in the visible region will be 0.5 n.m., with 4.0 n.m. in the infrared.



Figure 3-9 shows the variation of optics size with resolution. These curves assume a single detector system; but, like the VISSIR, detector arrays may be used to reduce bandwidth and, hence, required optics sizes -  $\sqrt{BW} \propto$  optics diameter.

A nearly optimum radiometer design, (requires an earth-oriented spacecraft) not possible with a spin stabilized spacecraft, would be to utilize a high duty cycle oscillating scan mirror. Comparative sizes are shown below:

	<u>VISSIR</u>	<u>MCSR*</u>
Weight (lb)	164	35
Optics Dia. (in)	16	8
Gnd. Resolution (n.m.)	0.5 VIS, 4.0 IR	0.9 VIS, 5.5 IR
Bandwidth per Detector (kHz)	2.0 VIS, 0.25 IR	4.5 VIS, 0.7 IR
NE $\Delta$ T at 200°K (°K)	1.7	0.2
Frame Time (min)	18.2	20.0

It is significant to note that the radiometer size to achieve 0.5 n.m. in the IR would be prohibitive. A 0.25 n.m. resolution in the visible channel, for a MCSR type design would require an IFOV reduced by 4 and an increase in bandwidth by 4 (if a 40 detector array is used) and a corresponding increase in the collector diameter by a factor of  $\sqrt{64}$  or 8 to 64 in., an unrealistic value.

A resolution of approximately 4 x 2 or 9 n.m. could be achieved in the 6.7  $\mu$  region by a VISSIR type instrument. Similarly, one could add a 1.0  $\mu$ m channel at a resolution of 1.0 n.m. These two additions would, however, increase the instrument size by 15 to 25 percent.

Figure 3-9 should be used for relative comparisons only, actual detector sensitivities and system F/number will vary the actual optimum design values.

### 3.2.3 Communications

The user request for increased received signal power is not well defined since no minimum received power level is specified. The ITOS system design meets the normal minimum threshold criteria for FM systems. The system design

\* Multi-channel Scanning Radiometer as proposed by RCA/AED to Japan as part of the Geostationary Meteorological Satellite System Study.

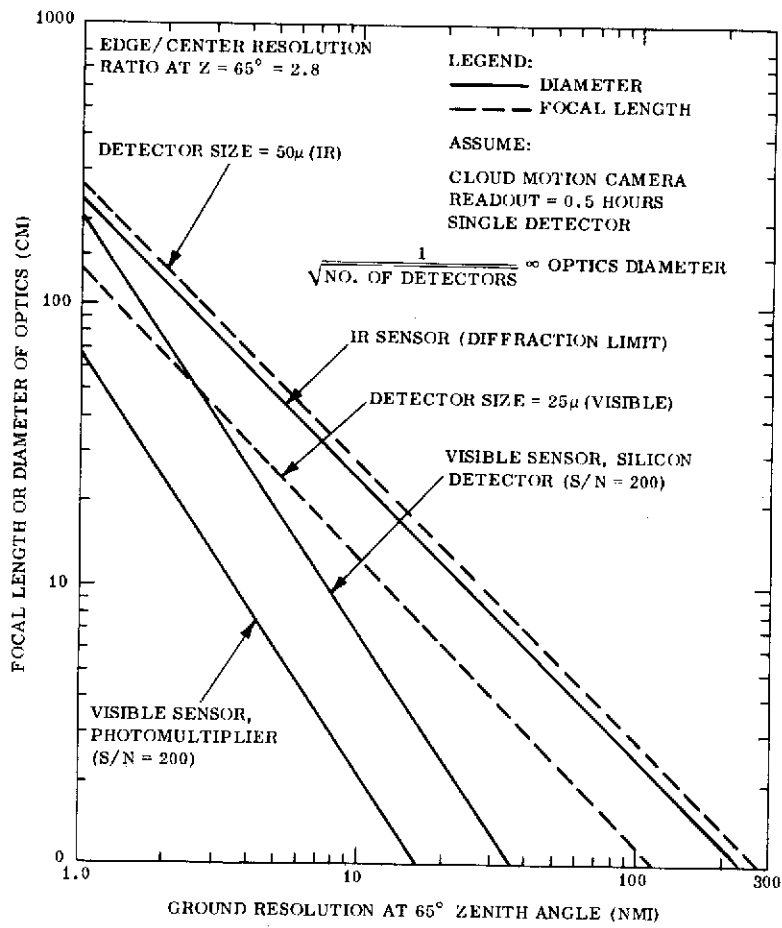

Figure 3-9 Optics Size for a Radiometer at Geostationary Altitude.

could not consider specific environments where local noise interference conditions exist. However, the requested increase in received signal level could be accomplished by 1) increasing ground antenna gain, 2) increasing spacecraft antenna gain, or 3) increasing spacecraft transmitter power. An improved antenna system providing 5-8 db increase in effective isotropic radiated power will be used to satisfy this need.

The unconstrained system must satisfy other communications problems concomitant with requests for additional channels and resolution requirements. These problems are considered for both the low altitude satellite and the geostationary satellite.

Current and presently planned direct readout systems use a VHF link for transmission of medium resolution real-time video (2.0 to 4.0 n.m.) and an S-band link for the transmission of medium and high resolution real-time data (0.5 to 4.0 n.m.). The low altitude ITOS satellites will use both links; whereas the Synchronous Meteorological Satellite will transmit only at S-band.

#### 3.2.3.1 Low Altitude Satellite Communications

The present APT system operates at 137.62 and 137.5 MHz with a useable bandwidth of 50 kHz allocated; video is carried on a 2.4 kHz subcarrier. Current real-time ground station receivers have a 50 kHz bandwidth.

The frequency bands 137-138 MHz and 400-402 MHz are applicable to the real-time service. NASA standards allow for assignments in 30 kHz increments up to 300 kHz in the 400 MHz band. Figures 3-10 to 3-13 show the respective link capacities in terms of signal-to-noise ratio and video baseband at constant C/N of 10 db. For the purpose of this comparison, direct FM modulation of the carrier was assumed. Table 3-6 shows the link summary at the 1500 n.m. altitude.

One requirement was to provide IR data with a NEAT of  $1^{\circ}\text{K}$  at  $200^{\circ}\text{K}$ . This represents a signal-to-noise ratio of 55 db, which, from an instrument standpoint, is readily achievable at the 2.0 n.m. resolution. Figure 3-13 summarizes the various VHF link capabilities in terms of resolution, number of channels, and orbit altitude. First note that transmission of 0.5 n.m. data is clearly impossible on this link. Also, note that the 55 db S/N ratio can be achieved only by the 2.0 n.m. resolution, non-rectified data. Even this achievement would require that a 90 kHz BW frequency assignment be obtained and that the receivers in all real-time ground

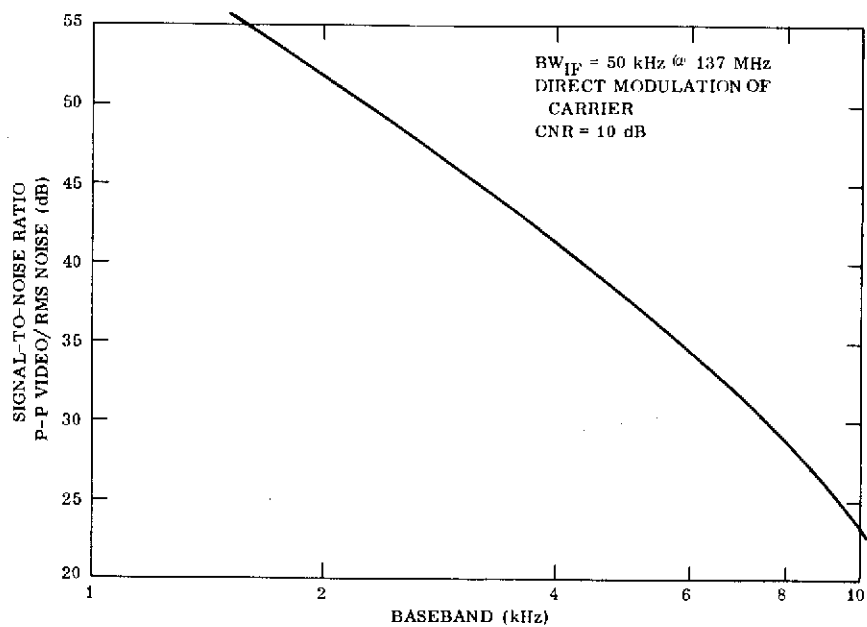

Figure 3-10 Signal to Noise Ratio vs. Video Baseband, Trade-off for Present VHF Real Time Stations.

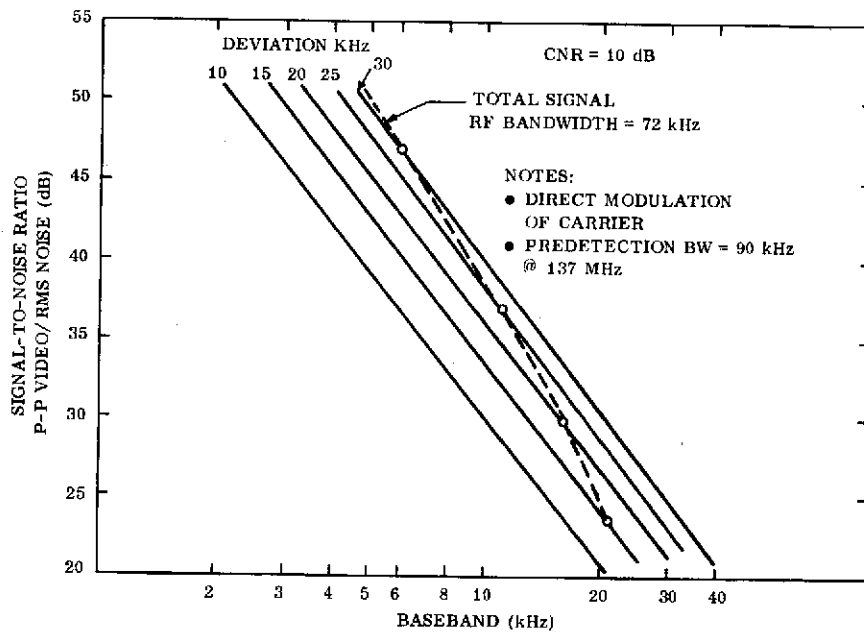

Figure 3-11 Signal to Noise Ratio vs. Video Bandwidth, Trade-Off for the Maximum Bandwidth Allocation of 90 kHz at 137 MHz.

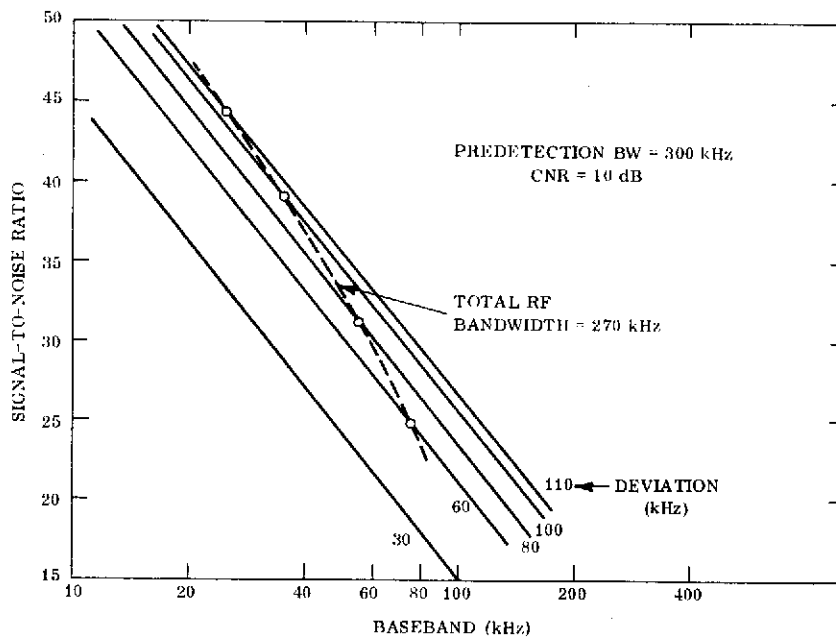

Figure 3-12 Signal to Noise Ratio vs. Video Bandwidth, Trade-Off for the Maximum Bandwidth Allocations of 300 kHz at 400 MHz.

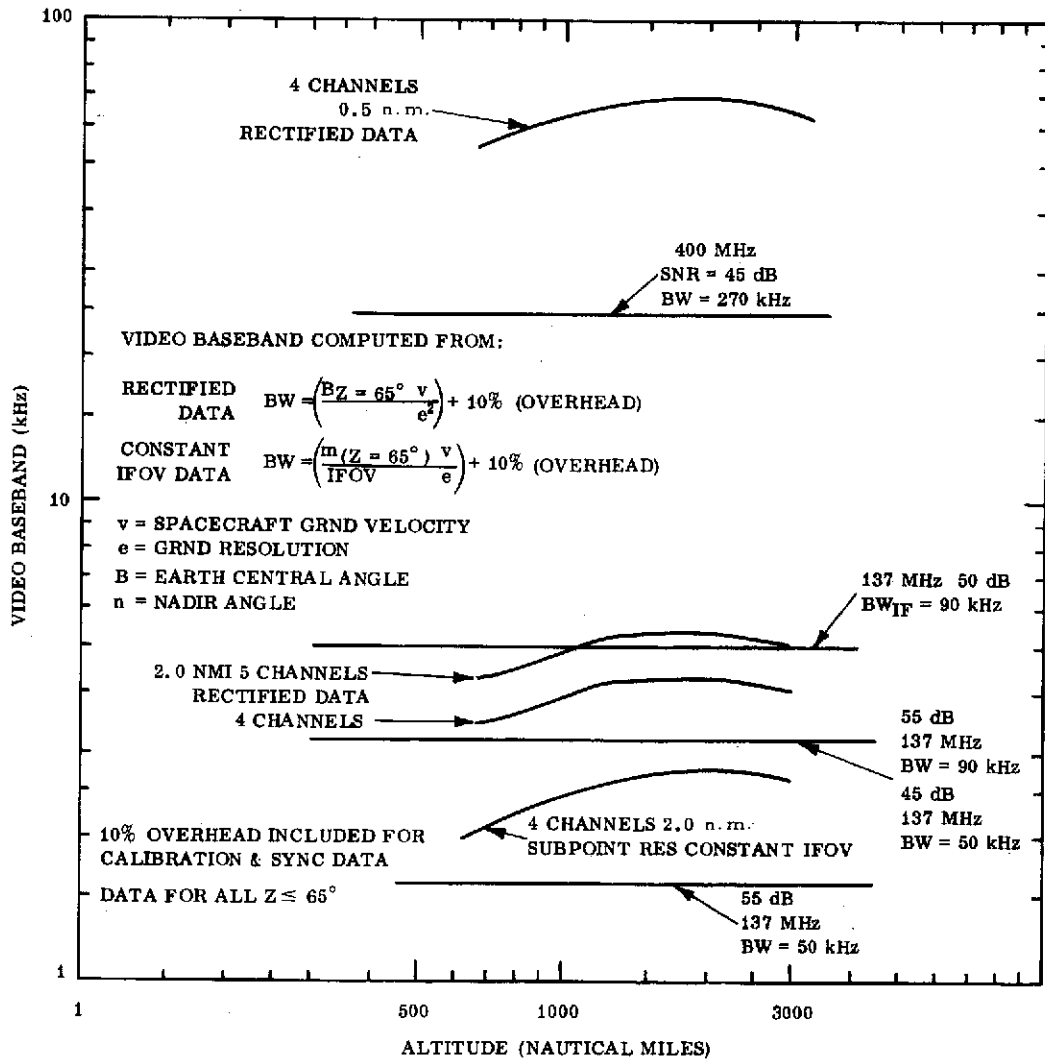

Figure 3-13 VHF Real Time Link Capability.

stations be increased to 90 kHz  $BW_{IF}$ . However, if the S/N requirement is relaxed slightly, 4 channels of rectified data can be handled at a  $S/N \approx 53$ db. The current system ( $BW_{IF} = 50$  kHz) will permit four channels of 2.0 n.m. non-rectified data to be transmitted at a S/N ratio of  $\approx 50$  db, as a direct baseband modulation of the transmitter.

Current plans include a real-time digital S-band link to a Direct Readout Ground Station (DRGS). This ground station will be serviced by both the SMS and the ITOS 'D' series spacecraft. The current frequency allocation for the SMS down-link is 4 MHz BW at 1687.1 MHz. The transmitted data is 1.7472 Mbps-NRz format. The DRGS bit synchronizer has an upper limit rate capacity of 2 Mbps.

TABLE 3-6  
137 MHz Parameters

<u>Item</u>	<u>Value db</u>
S/C Tx Power (7watts)	+8.5 dbw
S/C Line Losses	-1.5
S/C Antenna Gain at 45°	+5.0 (90° beamwidth)
Path Loss (10° elev., 1500 n.m. orbit)	-150.1 (3000 n.m. range)
Polarization Loss	-2.0
Ground Antenna Gain (APT Helix)	+12.0
Ground Line Losses	-1.6
NET RECEIVED POWER	-129.5 dbw $BW = 90$ kHz
Noise Pwr on RF Bandwidth	-149.5 dbw $NF = 5$ db
CNR	+20 db
FM Threshold	10 db
Margin	10 db

Figure 3-14 shows the bit rate as a function of altitude and number of channels for a resolution of 0.5 n.m. A 10% overhead rate was included for calibration and sync data.

Clearly, the 0.25 n.m. data rate is not consistent with the DRGS design, but the data rates for the 0.5 n.m. resolution data are. Figure 3-15 shows altitude as a function of transmitter power for various combinations of ground antenna diameters and channel configurations. The current system design uses a



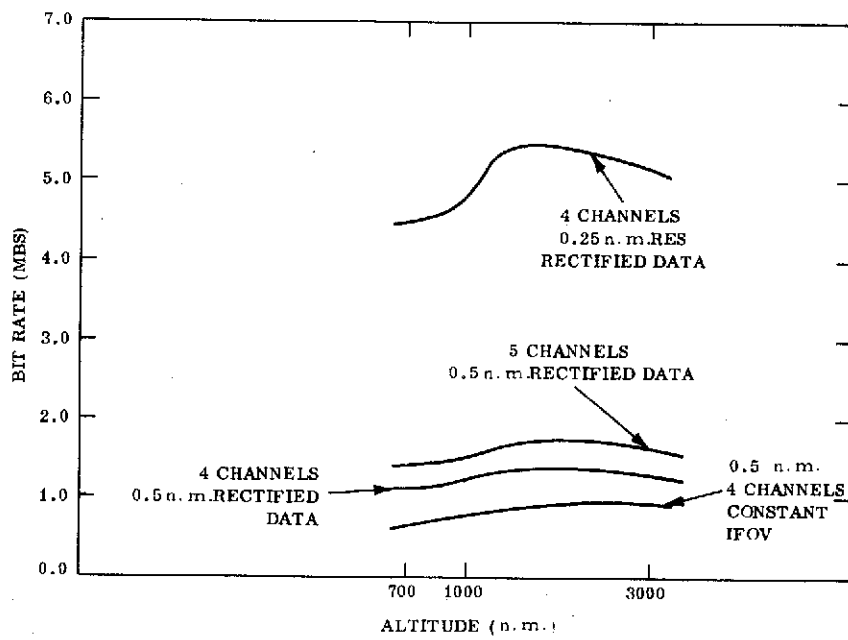

Figure 3-14 Data Rates for Real Time High Resolution Data for Low Altitude Spacecraft (Digital Processing for Bandwidth Optimization is Assumed)

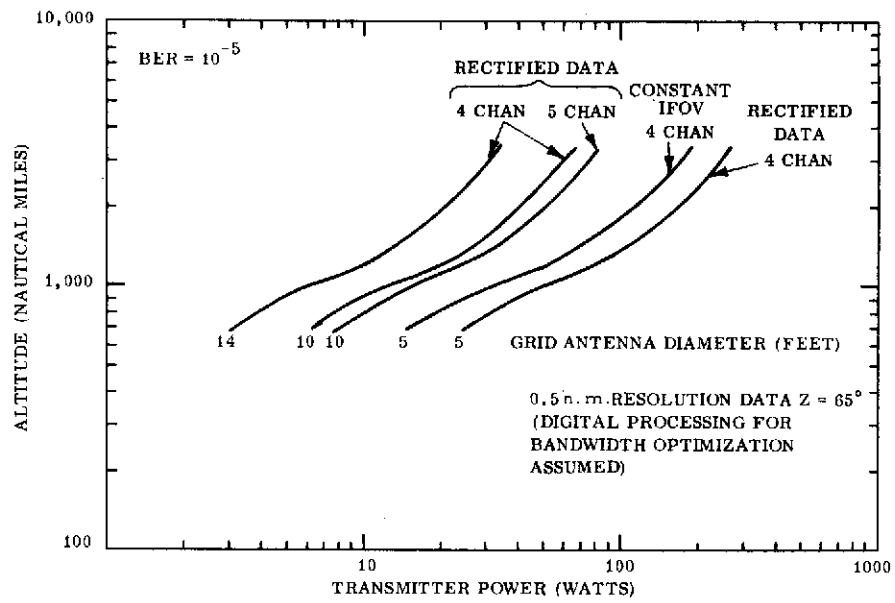

Figure 3-15 Digital S-Band Link from Low Altitude Spacecraft.

ground antenna of either 18' or 12'. One of the requirements to be considered by this study was a link design to accommodate a smaller ground station antenna.

The following link analysis was used in the generation of Figure 3-15.

<u>Item</u>	<u>Gain (db)</u>
Transmitter Power	+A dbw
S/C Losses	-.5
S/C Antenna Gain (elev. angle = 5°)	<u>+4.2</u>
EIRP	(A+3.7)
Path Loss	B
Ground Station Antenna Gain	<u>C</u>
Downlink Loss	<u>B-C</u>
Received Power	(A+3.7)-(B-C)
Received Noise Spectral Density (300°K)	-203.8 db/Bit
Received Signal/Noise Density	<u>(A+3.7)-(B-c)+203.8</u>
Bit Rate	D
Received Bit Energy/Noise Density	<u>(A+3.7)-(B-C)+203.8-D</u>
Received Energy per Bit/Noise Spec. Density	13.6
Margin	6

Note that to provide service to a ground station with only a 5' antenna would require an increase in spacecraft RF power from 10 (10' antenna) to 40 watts at the 907 n.m. altitude.

### 3.2.3.2 Communications from Geostationary Altitude

Figure 3-16 shows the relationship between spacecraft transmitter power, ground antenna size, and data rate for an S-band digital link from a geostationary orbit. The SMS real-time link will be a 1.7 MBS digital link at S-band using a 20 watt RF transmitter. Notice that this link is designed to service  $\approx$  18 ft. diameter ground antenna. The following table shows the data rate per channel as a function of resolution and readout time. A 2.5 sampling frequency, 8 bit quantization, and 10% overhead for sync and calibration data were assumed. Data was only taken out to  $Z = 65^\circ$  (in a square format).

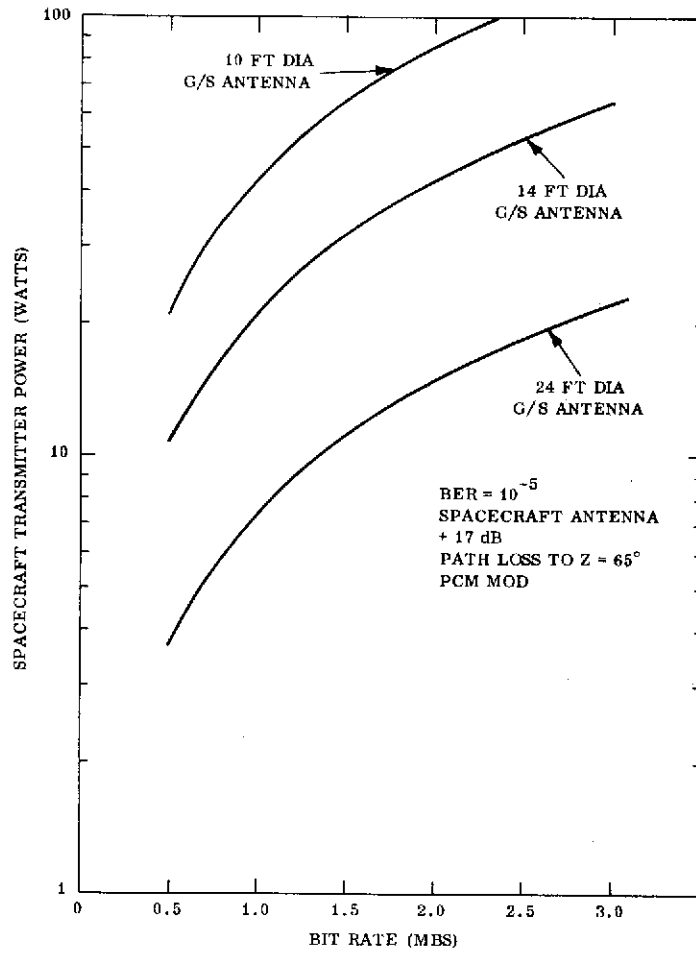

Figure 3-16 Transmitter Power and Bit Rate vs. Ground Antenna Size for Geostationary to Ground Station S-Band Link.

### Geostationary Data Rates (per Channel)

<u>Resolution</u>	<u>Readout Time</u>	
	<u>30 Min.</u>	<u>60 Min.</u>
0.5 n.m.	660.0 KBS	330.0 KBS
2.0 n.m.	42.3 KBS	21.2 KBS
4.0 n.m.	10.32 KBS	5.16 KBS

As was discussed previously, the best resolution one could reasonably expect to get at geostationary altitude would be: 0.5 n.m. ( $.7\mu\text{m}$ ), 1.0 n.m. ( $1.0\mu\text{m}$ ), 2.0 n.m. ( $11.5\mu\text{m}$ ), and 8.0 n.m. ( $6.7\mu\text{m}$ ). Assuming digital processing for bandwidth optimization, these 4 channels would need a rate of 870 KBS for a readout time of 30 minutes. Such a system (which would require a complete redesign of the sensor) could service a 15' diameter antenna with a 20 watt RF spacecraft transmitter.

#### 3.2.3.3 Trade-offs

In order that the results described earlier related to orbit altitude, transmitter power, instrument size, and processor size may be assessed quantitatively, the system capability was analyzed in terms of total spacecraft weight. This parameter can be related first to system cost in terms of the booster capability required to place a given spacecraft weight into a particular low altitude orbit. Present operational meteorological low altitude spacecraft are launched by the Thor-Delta series. Any increase over this particular booster's capability would cause a large increase in system cost, and would be highly undesirable.

A good estimate of the allocation of weight among the major subsystems in operational meteorological satellites can be obtained from the NASA TIROS-N Phase A Report.

Structure and Thermal	300
Power (Fixed Array - 250 watt load, 900 n.m.)	280
Data Processing and Storage	240
Communications and Command	110
Dynamics	100
Orbit Adjust	40
Sensor Payload	370
	1440 lb

This system includes the following functions:

1. Four channel scanning radiometer; 0.5 n.m. resolution in three channels, 2.0 n.m. resolution in the fourth.
2. Vertical temperature sounding radiometer subsystem.
3. Digital processing to obtain bandwidth optimization and resolution reduction to 2.0 n.m. in the three high resolution channels.
4. On-board orbit adjust subsystem to maintain daily constant ground track orbit.
5. A 10 watt S-band real-time digital link (4 video channels) and a 10 watt VHF real-time analog link (4 video channels).
6. Storage capability and a digital S-band playback link for centrally processed global data.
7. Attitude control to  $1.0^\circ$  about three axes; prediction to  $0.2^\circ$  all axes; attitude knowledge to  $0.1^\circ$  all axes.
8. All major subsystems are redundant.

An estimate of the power system weight can be obtained by expressing it in terms of the load power requirements and the orbit altitude for a given lifetime and a given type of system. Since this is an operational system, flight-proven processing systems such as the PWM Series Regulation or Direct Energy Transfer systems would be used. The lifetime would be at least two years. In a sun-synchronous orbit, optimum shadowing and illumination characteristics are given by the 0900 or 1500 local ascending node time orbits. This results in a maximum sun angle (incident with the orbital plane) of approximately  $60^\circ$ .

Using these above guidelines, an estimate of the power system weight may be obtained from the following equation:

$$W_{PS} = (2.2 \frac{\text{lb}}{\text{amp/hr}} P_L B_F) + (.03 \frac{\text{lb}}{\text{w}} P_L + 10.0) + 1.45 \frac{\text{lb}}{\text{ft}^2} \frac{P_L}{F}$$

where  $W_{PS}$  = total power system weight - array, battery, processor (lbs)

$P_L$  = orbit average load power (watts)

$B_F$  = battery capacity factor; DET system  $(\frac{\text{hr}}{\text{volt}})$

$F$  = array factor  $(\frac{\text{watts}}{\text{ft}^2})$

and  $B_F = \frac{t_e}{V_B \times \text{DOD}}$  ;  $F = e P_A D_r \frac{t_s}{p}$

- $t_e$  = eclipse time (hr)
- DOD = depth of discharge = 22%
- $V_B$  = battery voltage (avg) = 20 volts
- $e$  = overall average processing system efficiency = .72
- $P_A$  = power per square foot of solar array at  $= 60^\circ$  including string length and temperature effects =  $5.0 \frac{W}{ft^2}$
- $D_r$  = radiation degradation factor (see Figure 3-17)
- $T_s / p$  = fractional orbit sun time

Using this estimate, power system weight as a function of altitude was computed. The total spacecraft weight is shown in Figure 3-18 for a 250 watt and for a 500 watt load system, along with the capability of the Delta 2910 booster. Note that the maximum altitude for the TIROS N spacecraft (250 watt load) would be 1120 n.m. Therefore, since a 250 watt load appears to be the requirement for the minimum mission, a 907 n.m. altitude, two satellite system is the only one of the several low altitude systems mentioned earlier which can be launched by the Delta booster.

Another interesting insight into cost trade information can be obtained by estimating power system cost as a function of orbit altitude and orbit average load power for that orbit altitude. This cost estimate may be obtained from the following equation:

$$C_s = \left( \frac{3\$K}{ft^2} \frac{P_L}{F} + .2 \frac{\$K}{W} P_L + P_L B_F \frac{2\$K}{amp/hr} \right) N + 3 \frac{\$K}{W} P_L$$

$C_s$  = total program power system cost at buy/sell

$N$  = # of spacecraft in program

Figure 3-19 shows  $C_s$  plotted as a function of orbit average load power for two altitudes. Note that if the load power is doubled, the cost is approximately doubled. This is a result of the fact that array size and battery size are approximately proportional to load power.

As an appropriate application of the above information, consider the real-time S-band communications link. In order to transmit 4 channels of constant IFOV (non-rectified data) into a ground station with a 5' diameter antenna from 907 n.m., an RF power output of  $\approx 40$  watts is required. State-of-the-art efficiency for a transmitter consisting of a power converter, modulator, and amplifier would be

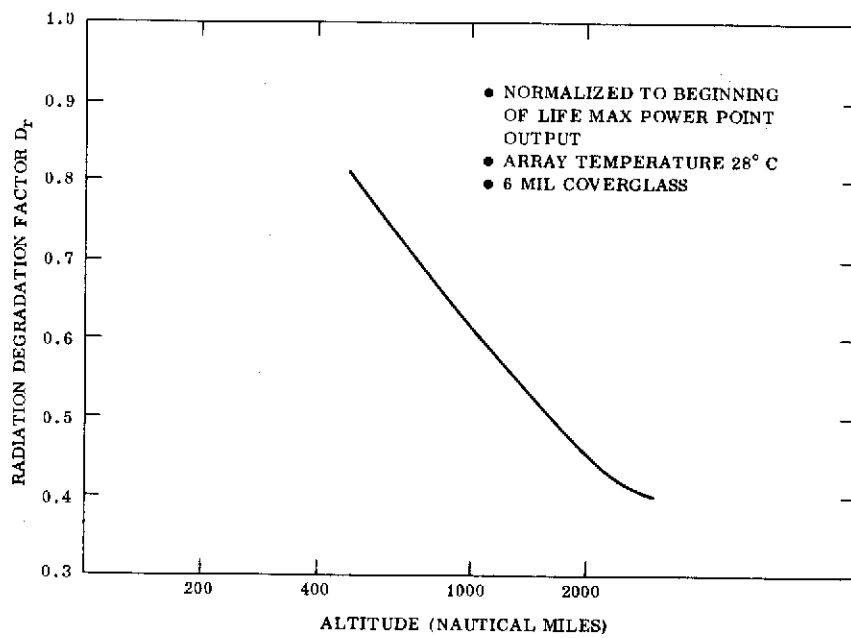

Figure 3-17 Solar Array Degradation after 2 Years as a Function of Altitude.



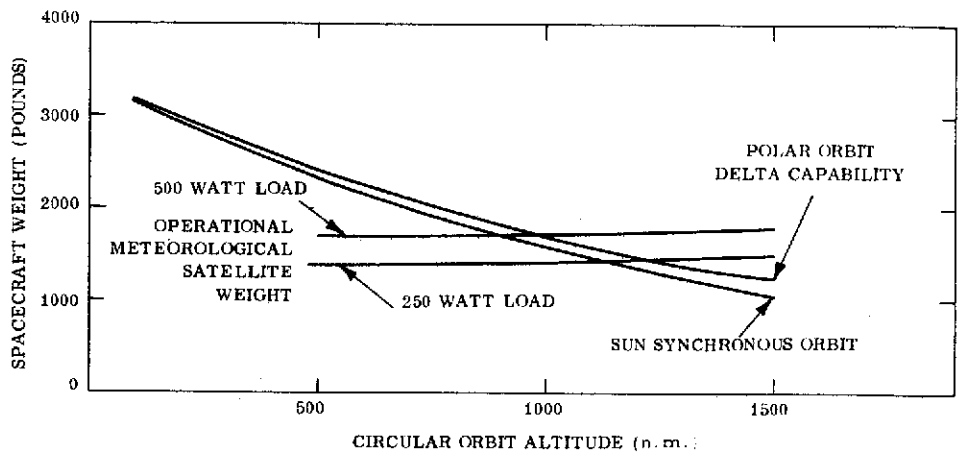

Figure 3-18 Delta 2910 Spacecraft Weight Capability (WTR Launch), Fixed Array,  $\sigma = 60^\circ$  max.

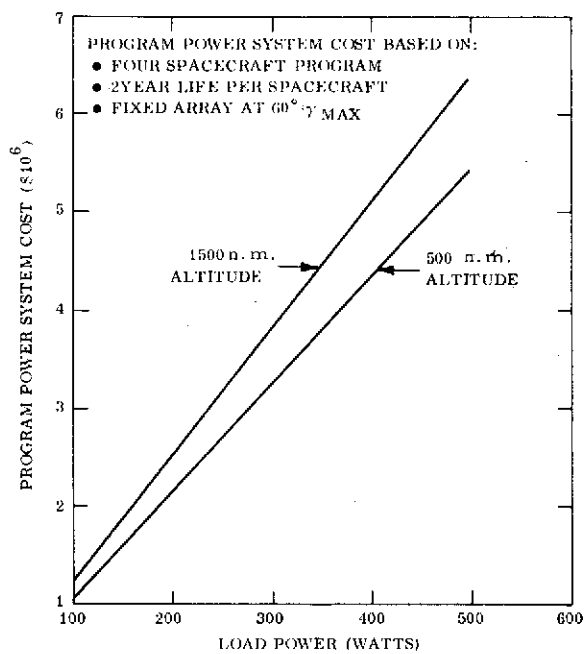

Figure 3-19 Program Power System Cost.

approximately 30% overall for a TWT. Thus, if the rest of the spacecraft systems remain unchanged from the TIROS-N estimates, a load power increase from approximately 250 watts to 350 watts would be required, increasing in program cost by \$1,000,000 for the power system alone. Furthermore, from the launch vehicle capability curve in Figure 3-18, it can be seen that the spacecraft weight has been raised to near the upper limit for the 907 n.m. orbit, leaving little room for increase in sensor size or additional data processing equipment.

Similarly, for the SMS launch to geostationary altitude, the Delta 2914 is the planned booster. This booster can put 1500 pounds of useful weight into the transfer orbit with apogee at synchronous altitude, but this weight must be divided between the spacecraft and apogee kick motor. The maximum useful spacecraft weight would be  $\approx$ 725 pounds. Since SMS is already near this upper weight limit, any proposed addition for the DRS system would require a step increase in cost. The following table is a gross estimate of recurring cost, not including launch costs, for several boosters.

<u>Vehicle</u>	<u>Spacecraft Wt. (lb)</u>	<u>Cost (\$10<sup>6</sup>)</u>
Delta 2910	725	5.0
Atlas Agena	1387	8.8
Atlas Centaur	2000	11.7

### 3.2.4 Data Handling

#### 3.2.4.1 General

Two types of data exist in the Direct Readout Meteorological System: sensor data and utilization support data. This latter category of data defines parameters which are necessary for sensor calibration (such as the equivalent temperature of a reference surface) or geographic referencing (such as spacecraft position, height, attitude, etc.). Ideally, the station receiving sensor data, regardless of size, should never require any supporting data other than an initialization of parameters peculiar to the spacecraft configuration or ephemeris. For the operational local user especially, all ground processing should be avoided since ground processing implies a higher required skill level for the ground station operator, delays the availability of the product, and implies a higher cost for the total meteorological system complex when ground processors are duplicated several hundred times. Accordingly, this unconstrained system contains little provision for processing of

support data. Grids are either included in the sensor data itself or are simply applied to image data from satellites producing constant ground tracks. Sensors are self-calibrating so that absolute levels of radiation are maintained for any given analog or digital level transmitted from the satellite.

The primary data (sensor data) should be treated quite differently. Any processing done in the spacecraft alters the raw data forever as far as the direct readout receiver is concerned. The researcher obviously wants his data in as raw a state as he can get it. However, we are probably more concerned with the receiver who has operational requirements, since he forms the largest part of the user community.

Two missions exist for the operational user with a small ground station. Section 2 defined the missions to be synoptic scale forecasting for ground stations which are lacking other sources of meteorological information, and short range forecasting requiring high resolution data.

These points are reiterated here because the primary type of sensor data processing currently under consideration is resolution reduction to fit the capacity of the projected communications links. Before proceeding any further, the question of what communications links are "available" to the small station-operational user should be addressed.

A satellite with a four channel sensor yielding 0.5 n.m. resolution data requires a 10 foot or larger dish to receive the data for a vehicle altitude of 900 miles and a transmitter power of 10 watts (See Figure 3-15). Costs associated with steerable 10 foot dishes, capable of survival in adverse weather, added to the receiver costs for S-band operation, suggest the desirability of reducing the bandwidth or the quantity of data transmitted to the ground station.

#### 3.2.4.2 Reduced Area Transmission of High Resolution Data

One possibility for satisfying the high resolution data requirements of Class 2 ground stations arises when it is realized that high resolution data is not needed at large distances from the small ground station. A distance of 500 miles from the ground station probably represents a maximum range of interest. The area of interest for high resolution data is very likely to be 1/16 of the area of interest for the lower resolution data. A processor can be employed on the satellite to create a number of overlapping subswaths out of the base swath. For purposes of illustration, assume a base swath of 2000 miles width. The first 800 rectified picture

elements are fed to a buffer from which the elements are extracted over the entire duration of the sensor scan, and transmitted to the ground over frequency F1. Starting with picture element 400, 800 consecutive picture elements are stored in a second buffer, from which the data is transmitted over frequency F2, and so on.

The concept is illustrated in Figure 3-20. For any point in the swath, the satellite transmits back the local subswath data. Subswath overlap is 50% with the adjacent subswath, guaranteeing that any ground station can receive data out to at least 200 n.m. for a 2000 n.m. base swath. A bandwidth reduction of 2.5 is obtained since only 40% of the data for a full line is transmitted over any one channel. Figure 3-21 shows desired antenna patterns for each channel. Assuming both a bandwidth reduction and an increase in antenna gain, only  $1/(2.5)^2$  times as much power need be transmitted for a single subswath relative to the power for the total swath.

The bandwidth reduction, unfortunately, is realized for only one dimension of the image scan, i. e., the cross-track dimension. To accomplish a similar gain in the along-track dimension would require a rocking of the sensor in the sub-path direction or a snapshot type of operation such as the early APT. Since the scanning radiometer offers much in the way of simplicity of hardware and ease of data reduction, a further reduction in bandwidth is not contemplated.

However, in terms of reducing the required transmitter power, the reduced area for high resolution imaging offers an additional benefit if the antenna beam is also shaped in the along-track dimension. For a distance of 1000 n.m. ( $\pm 500$  n.m. from the station) for receipt of data, the energy of the transmitter can be restricted to an angle of approximately  $60^\circ$  for a 900 n.m. orbit. Relative to the approximately hemispherical radiation pattern currently in use, an additional factor of 2 to 3 in power reduction is possible.

In summary, limiting the data coverage around a ground station to a radius averaging 300-400 n.m. high resolution data can be received with a ground station receiver bandwidth which is 40% of that required for full swath coverage. Four transmitters are required in the satellite at each of four different frequencies, and directional antennas must also be provided. However, the total power for all four transmitters is less than that required for a single transmitter relaying the high resolution data for the total swath. Maintaining the total transmitted power the same for either case, permits a reduction in the diameter of the ground station antenna required of the order of 50%. Since antenna costs tend to increase with the square of their diameter, this is a significant saving.

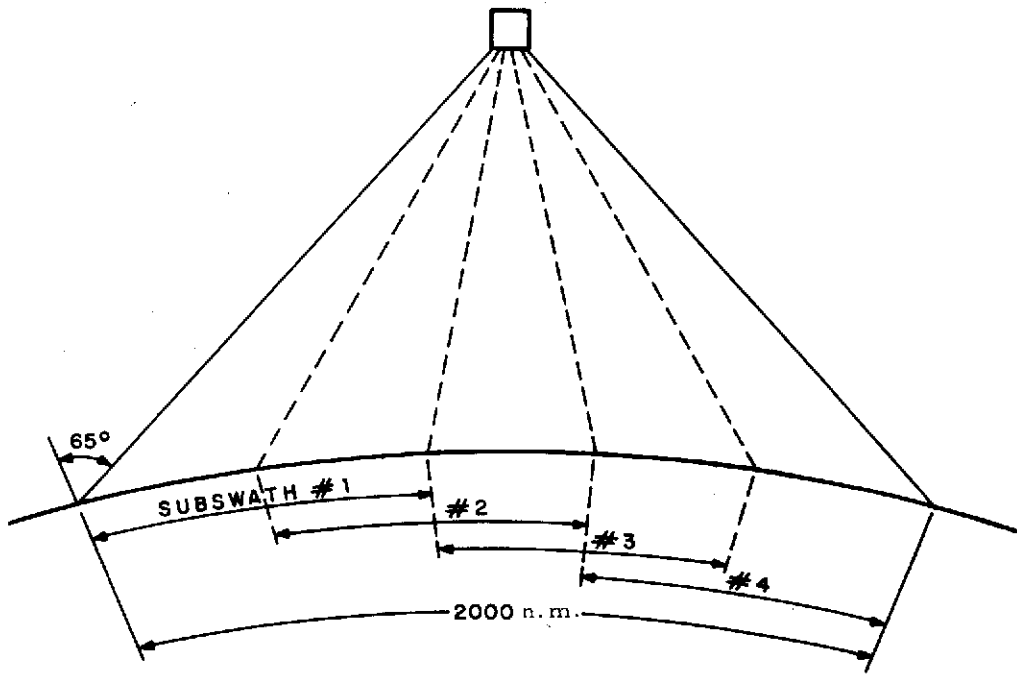
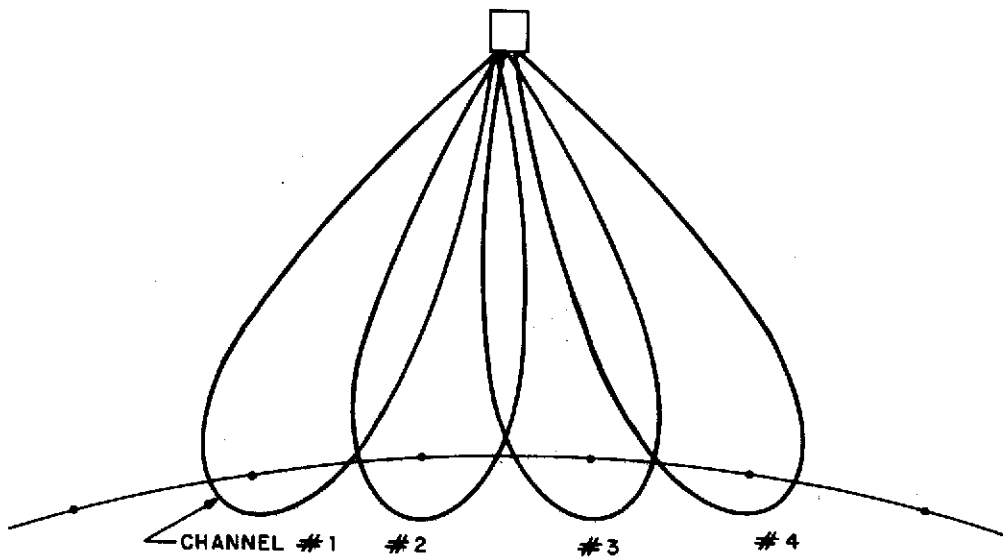

ILLUSTRATION OF SWATH SUBDIVISION

Figure 3-20



SPACECRAFT ANTENNA PATTERNS FOR SUBSWATH DATA CHANNELS

Figure 3-21

A spacecraft equipped with such a system as described above, should also retain a separate channel for broadcast of lower resolution, wider area data, required by stations lacking other sources of meteorological data for synoptic forecasting.

#### 3.2.4.3 Digital or Analog Data

Where ground processing is desirable, its outstanding characteristic should be flexibility. In response to the user questionnaire, NOAA said that "the spacecraft is designed for the convenience of the spacecraft and not for the users." This comment may be appropriate largely because of the inflexibility of current ground stations. The reduced width of the HRIR display on some APT receiving systems is an excellent example of inflexibility of ground stations resulting in an unnecessary and weakly justified hue and cry.

It was disturbing to note that the preliminary design of TIROS N was apparently constrained to retain a compatibility with existing APT stations. It has been suggested that AVHRR 1/2 mile data (in digital form) be averaged to produce 2 mile data, and then be converted back to analog data for AM modulation of the APT subcarrier. This compounding of A-D and D-A conversions increases equipment complexity, degrades the data, and leaves the data received at the ground station in the analog form which is largely responsible for the inflexibility of APT receiving stations. Factors which demand that Direct Readout data be in digital form include:

- 1) Sensor/digitizer systems are easily calibrated on the spacecraft. As long as sufficient margin is designed in the communications link to ensure a bit error probability of about  $10^{-5}$ , the data quality is insensitive to variations in modulators; transmitters, receivers, and recorders.

- 2) Digital data systems will be less sensitive to the emanations in the RF environment such as automobile ignition noise and shipboard radars.

- 3) Multichannel data can easily be mixed in a single bit stream, allowing sensors and formats to change without major impact on ground stations data processing equipment. (Use of a programmed data processor on the ground is assumed.)



4) A variety of displays are, or can be, readily interfaced with a computer for data reception, permitting tailoring of the display to the desired product or easy incorporation of new displays as they become available.

### 3.2.5 Displays

Rapid analysis of meteorological satellite imaging is currently limited to display devices more than by any other element of the ground station. Facsimile is the most popular display device, but some facsimile displays present a severe limitation to achieving a wide gray scale, and the user survey strongly suggests 1° sensor resolution over a 200° range. Facsimile is also very inflexible with regard to numbers of picture elements per line and line rates.

The elements of most ground systems are a receiver, a storage device, and a display device. The storage device is necessary if any versatility other than a direct on-line input to the display device is desired.

- A. Candidate storage devices include:
  - 1) Magnetic tape
  - 2) Magnetic disc
  - 3) Electrical storage tube
  - 4) Direct view storage tube.
- B. Candidate display devices include:
  - 1) Facsimile devices such as described in Section 1
  - 2) Direct view storage tube with camera or vidicon
  - 3) Cathode ray tube with or without attached camera
  - 4) Electron beam recorder
  - 5) Laser recorder.

A number of the devices listed above will be described further as the recommended system emphasizing the requirements of the Class 2 meteorological users is developed. A brief description of the others follows:

#### A. Electrical Storage Tube

This type of storage tube is available with capability to store an image in excess of 4000 lines. A portion of the stored data can be selectively retrieved. The output is electrical and

so must be used to drive other single or multiple displays.

B. Direct View Storage Tube

This type device has much the same storage capacity and retrieval versatility as the electrical storage tube. However, the output is a video display rather than an electrical signal. Thus it cannot drive other display devices and would normally be used with an attached camera or vidicon.

C. Electron Beam and Recorder

Typical performance of this type device which is supplied with digital data from storage (drum or tape), is:

- 1) records up to 60,000 points per second
- 2) 64 repeatable gray levels on high speed film
- 3) 256 energy level modulation
- 4) Optical density range from 0 to 2.5D
- 5) Raster apertures from 12.5 to 200 microns
- 6) Standard format 8 1/2 x 10 inches (larger available).

These types of devices are currently feasible, but lack of production experience and solid cost figures make their further consideration tentative for a standardized operational system.

D. Laser Recorder

This type of device may prove to be practical as a display device for direct readout. Present plans call for a version of it to be put into widespread use by the Associated Press in a new facsimile system. Some 5000 installations are planned by 1976. The device is being developed by M. I. T. The AP equipment will transmit/receive pictures eleven inches wide at a resolution of 100 lines per inch at a rate of 100 lines per minute. The relatively slow rate is due to the limited capacity of the conventional voice telephone circuits used for transmission. The basic components are capable of appreciably better performance. A variant is now under development for digital transmission of X-rays at 56,000 bits per second and a resolution of 300 lines per minute. A print wider than eleven inches is feasible.

A one milliwatt modulatable helium-neon laser is used as the energy source, with horizontal scanning provided by a galvanometer driven mirror and vertical scan provided by continuous paper feed. Dry silver paper will be used in the AP system as the recording medium which is processed in a small oven. Adaptions to use other recording mediums are possible. The laser tube has a projected lifetime of 18 months and will cost from \$100 to \$175. The one miliwatt energy level poses no safety hazard. The cost of the AP device is projected to be about \$5,000.

With regard to the display, two questions should be asked. Is an image display a required readout? Is hard copy required?

The answer to the first question is yes, if the needs of the small station with operational requirements are considered. No other mechanism can so quickly convey so much information to a human observer. The need for hard copy is debatable. As long as an operator can sustain a display, or recall the display from an electronic store, he can accomplish his prime function of short-term, detailed weather forecasting.

Although this report emphasizes the requirements of the Class 2 meteorological user and the meeting of his requirements gets the main emphasis in the development of the recommended system, it is recognized that there are users of direct-readout data from meteorological satellites other than operational meteorologists. Ice forecasters, hydrologists, oceanographers, and others dealing in applied environmental sciences are examples. These users will require differing types of displays depending upon the characteristics of the phenomena they are concerned with and their operational methods. Some of these users will need high quality, hard copy data. Thus, it is obvious that a standard display system will not suffice for all users. And, although standardization is in many ways desirable, the need for versatility is essential.

Users who are categorized in Class 3 have budgets which will force them to await advances in the state of the display art. They require the price advantages of mass production.

Class 2 users must have something new in the very near future. One attractive possibility is a mini-computer-aided CRT display. A second is a direct view storage tube, again computer driven. A third is a synthesis of these, using

an electrical read and write storage tube to drive the display CRT. A variant of this last is currently used for onboard displays on military aircraft, where a computer is used in conjunction with a CRT to display Aircraft Management, Fire Control, and alternative sensor displays (radar, infrared, sonar, TV). This approach has replaced DVST displays in the A-6 and F-4, and new installations have been made in the S-3 and P-3. The technique is also used in Air Traffic Control operations to display radar and computer generated alphanumeric simultaneously.

The use of a small digital computer is assumed for any Class 2 station. Small digital computers are available at a currently moderate (\$5,000 for a processor with 4K memory), and still decreasing cost. Their flexibility and usefulness for display control alone warrant their use. Additional functions which could be performed with a mini-computer include antenna pointing, gridding, rectification, gamma control, temperature contouring and superposition of temperature data onto visible cloud cover imaging.

#### 3.2.5.1 Direct View Storage Tube Versus CRT

Direct view storage tube (DVST) displays suffer a requirement to erase and rewrite when data is to be modified on the display. Although this interval can be short, of the order of 1/2 second, an operator (data analyst) attempting to interact with the display system and modify the display content, would be disturbed by the continual interruption and blanking of the display. Some of the operator interactions with the display, to be recommended in a subsequent section, require a smooth continuity of operator command and display reaction. Accordingly, DVST displays will not be considered further for Class 1 and Class 2 users. They are considered appropriate for Class 3 users using an attached camera or video display.

The cathode ray tube offers potential since its data can be rapidly updated, and high quality monitor CRT displays can be obtained at reasonable cost since they are produced in volume for studio monitoring. Although it is difficult to produce more than 32 discernable shades of gray, techniques such as modification of the output brightness/input radiance transfer function (gamma) can be employed to work around the limitation. Expansion of a limited radiance band to fill the dynamic range of the CRT is one example.

The most serious limitation of a CRT arises as a result of its most attractive feature. Its ability to accommodate rapidly to scene changes arises from its

use of a short persistence phosphor. However, the short persistence phosphor requires that the display be refreshed often. Conventional TV is updated with new information 30 times each second (frame rate). Interlace applies half of the frame at a time for a "field" rate of 60 per second. However, since scene motion does not approach TV requirements, a higher persistence phosphor can be used.

A five frame, fifteen field display is feasible since no motion exists in the displayed image. However, since the operator should be able to modify the display (in a manner to be described in a following section) without disturbing lags, a ten frame/thirty field per second display represents a good compromise. This would yield a bit rate of 29.4 megabits per second.

Eight bits of information will be available from the satellite for each image element. If 700 elements are to be displayed along a scan line and 525 lines appear on the display, the average bit rate for a 10 frame/sec. display is:

$$(8) (700) (525) (10) = 29.4 \text{ megabits/sec.}$$

If data is read from a computer in 16-bit words, the word rate would be 1.83 MHz which is too fast for most mini-computers, even in the direct memory access mode. Rates of this magnitude also assume a core or plated wire memory, and the required 183K words represents an impossibility large high speed memory.

A drum is an ideal buffer for CRT refreshing. Drum rotation rates are usually one-half or one times the power line frequency, and 30 revolutions per second is common. A 30 rps drum containing one "frame" of information would refresh a CRT at the desired frame rate if one third (one field) of the contents of the frame were read every revolution. The frame of the example above required 183K words of storage, a modest requirement for presently available drums. The one parameter whose value represents a significant departure from that commonly associated with low cost drums is the read speed. These drums typically employ a single read amplifier which is time-shared among the heads (64 heads would typically be required for the 184K word storage). At the bit densities commonly used, a one-track-at-a-time readout would yield a bit rate of approximately 1 MHz. To satisfy the CRT requirements for a ten frame 525 line picture with eight bits per element, 32 sets of read electronics (one per track) will be required. A survey of drum and disk type memories should be made to establish the most cost effective

tradeoff for track recording densities and number of tracks. However, the drum capabilities, except for read electronics, match the CRT requirements sufficiently well that the drum/CRT is a feasible display device.

For the Class 3 user the non-destructive readout single-gun alternate read or write DUST, with 10 level gray scales, resolution of the order of 2000 lines across the display (2000 x 2000 elements per scene) are currently available, at costs of \$2000, and driven by electronics similar to those required for a vidicon TV camera costing a few hundred dollars.

It is recognized that such small (700 x 525) element images used in the example above might well represent less data than that available from a single satellite pass. Indeed, if any of the common display devices are to be used to display the total width of the swath, resolution will be lost. It is far better to look at a smaller part of the total scene at one time and see the image with all the resolution available rather than try to force a fixed width on the display which either requires a higher capacity and more costly display device or reduces the data resolution. A practical approach to the display problem consists of averaging the data in the computer for a low-resolution look at a large area, and then "expanding" the displayed image about areas of interest.

The Class 1 and Class 2 ground stations should be equipped with a mass memory, (large disc or magnetic tape) capable of recording all of the data from a pass. The computer should be used then to organize and select the data to be loaded into the CRT refresh memory.

The computer/CRT approach offers the potential of color presentations at the expense of ground processing time to develop the chrominance signals. An analysis to determine the impact of color presentations on processing time is advisable, but is beyond the scope of this report.

### 3.2.6 Processes to Facilitate Data Interpretation

#### 3.2.6.1 Rectification

The geometric distortion caused by sensor scan and earth shape can be readily removed from the scan normal to the orbit track. This correction can be made either in the ground station or on the spacecraft.

#### 3.2.6.1.1 Ground Station

Rectification is easily accomplished in a computer equipped ground station regardless of whether the data is in analog or digital form. (The distortion to be corrected is the cross-track foreshortening produced by a scanning radiometer rotating at a constant speed). If the data arrives in analog form, a digitizer can be computer-controlled to increase the digitizing rate as the scanner departs from the nadir. Since a circular orbit is highly probable, the spacing between samples will vary along a line in the same fashion for any scan line, permitting sample-spacing data to be stored in a few hundred words of core. The data in core would consist of the current spacing between samples plus the number of samples to be digitized before the spacing is changed. The sampling rate would be piecewise linear to conserve core storage.

If the data arrives at the ground station in digital form, extra samples would be created for the edge data by weighting and combining adjacent "real" data samples to affect a smooth transition between radiance values. The latter technique would consume more computer time than that required for handling analog samples, but could still be accomplished in real time with any mini-computer equipped with a hardware multiply and divide unit.

If data is rectified on the ground, the real "loser" is the Class 3 user since he must continue to receive distorted data.

Figure 3-23 is an example of rectified, constant resolution data. Figure 3-22 shows the unrectified, variable resolution data. Techniques for the ground based process for producing the constant resolution, rectified data were developed by the Astro/Electronics Division of RCA with internal research and development funds.

#### 3.2.6.1.2 Spacecraft

On the spacecraft, the correction can be performed at the time the data is digitized by varying the data sampling rate as a function of scan position. Alternatively, the correction can be made after digitization at a constant sampling rate by manipulating the data. The manipulation can be an averaging, an interpolation, or the transmission of redundant data.

Figure 3-24 illustrates how the ground resolution varies with scan position relative to the nadir. A constant rate digitizing system must sample the data





**RCA** Astro Electronics  
Division

IMAGE PROCESSING LAB

ITOS D - VHRR  
PROCESS: DIRECT I/O  
RESOLUTION: 1/2 N.MI.

Example of Unrectified Data ITOS-D-VHRR, Resolution 1/2 n. m. at the Sub-Point  
FIGURE 3-22



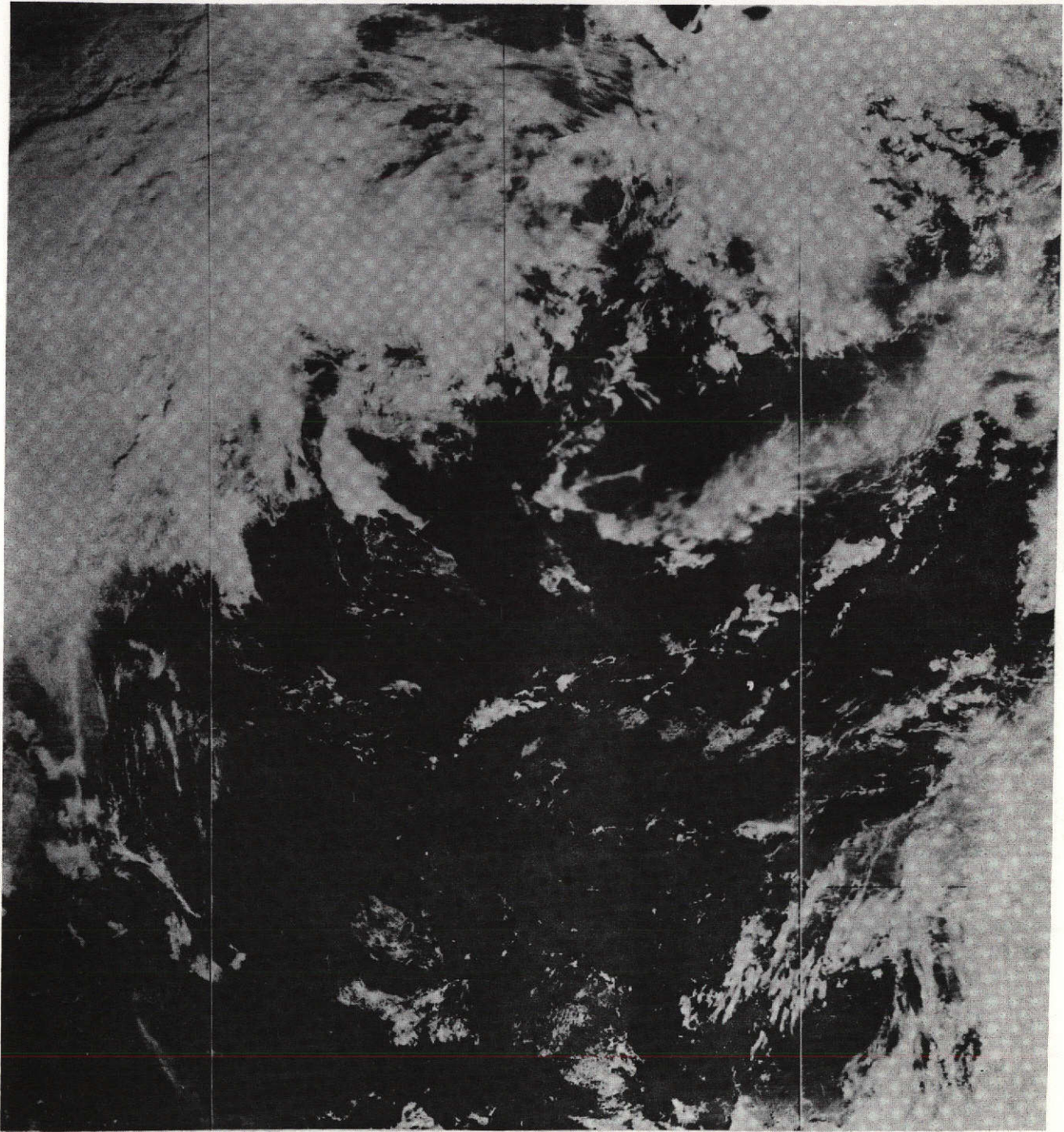

**RCA** Astro Electronics  
Division

IMAGE PROCESSING LAB

ITOS D - VHR  
PROCESS: 8 ZONE CORRECTION  
RESOLUTION: 2 N.MI.

Example of Rectified Data of Figure 3-22, Resolution 2.0 n. m.

FIGURE 3-23

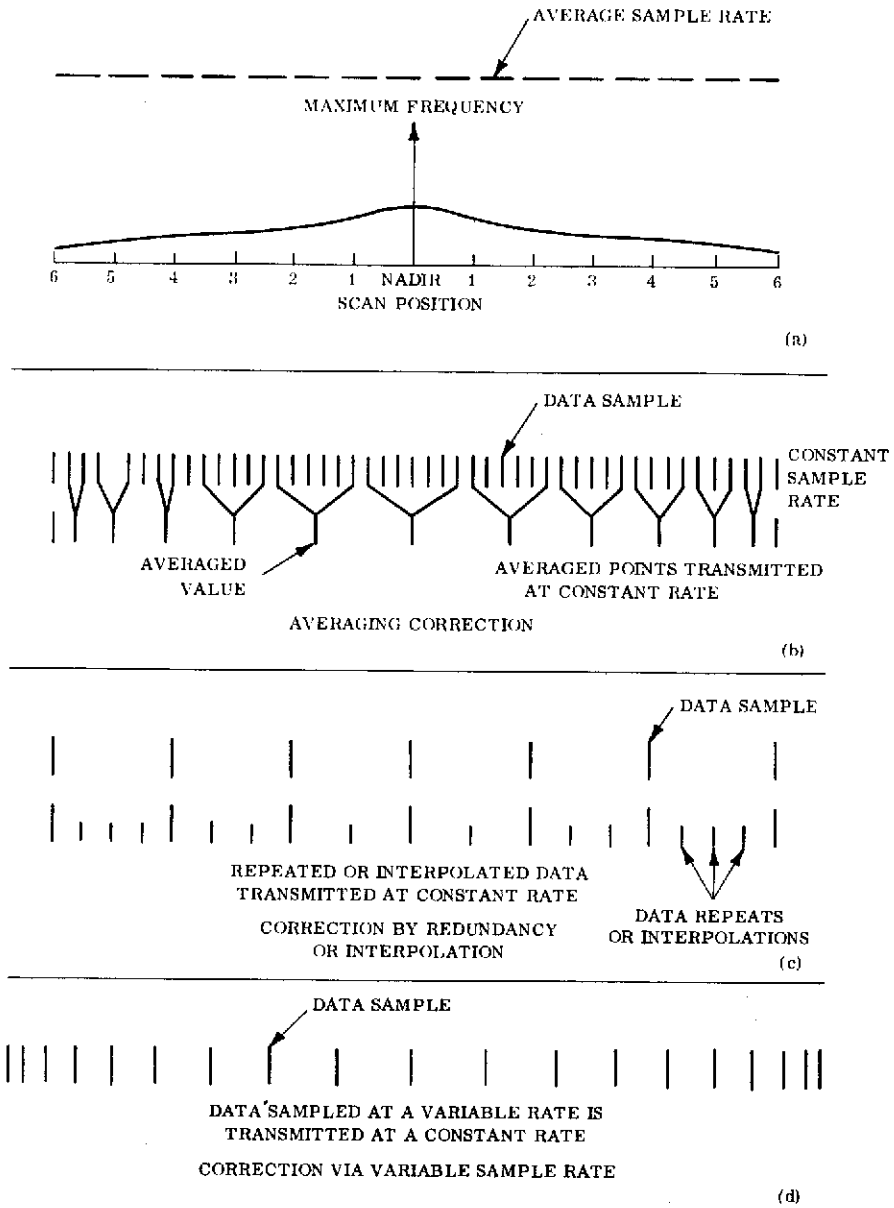

Figure 3-24 Scan Correction via Variable Scan Rate.

at a rate more than twice the maximum frequency of the analog signal. For a sensor with resolution greater than that which is to be transmitted, the rectification can be performed by averaging adjacent data samples near the nadir. Fewer samples will be averaged as the scan moves from the nadir. The average value is transmitted. Figure 3-24b shows a constant sample rate and the averaging technique.

If the sensor resolution sets the limit of the system, then the correction can be accomplished by transmitting more data samples as a function of distance of the scan from the nadir. The additional samples can be repetitive transmission of data points or interpolations between data points. Figure 3-24c illustrates this technique.

Figure 3-24d shows how the sampling rate must vary as a function of scan position from the nadir. With this technique, the geometric correction via sampling rate change can be a continuous function of scan position. However, the average data sampling rate is higher than that of the other techniques and hence a larger buffer storage is required.

The illustrations which are used to describe these techniques are intentionally simplistic. For instance, the ratio of edge resolution to subpoint resolution is not large enough to permit a gradual integral variation of averaged elements as the scan angle changes. A more complicated relationship must be used, which will not be developed here.

#### 3.2.6.1.3 Conclusion

Although rectification is easily accomplished in a computer-equipped ground station, it is strongly recommended that it be done on board the spacecraft. However, to attempt to process the data in the spacecraft to a specific map projection, is not the optimum procedure. One projection will not satisfy all users. The advent of the low cost mini-computer makes it more practical to do a basic rectification on the spacecraft and to do more flexible processing in the ground station if required, and to provide the Class 3 user with rectified data without a mini-computer capability.

#### 3.2.6.2 Sensor Calibration

On-board sensor calibration can be satisfied if signals corresponding to fixed or known temperature levels are transmitted as part of the data stream.

Signal points which can be used are provided by the scan of space and the scan of a surface of known temperature such as the housing back scan. The space temperature is known. The temperature of the back scan can be monitored with a temperature sensor, and that sensor output can also be transmitted with the data. All the necessary calibration data is then part of the sensor data stream.

While it is probably advisable to continue sending this type of data, these reference values can easily be employed to calibrate the spacecraft sensor-digitizer system automatically. In its most common implementation, a digitizer requires a reference voltage which usually feeds a digital-to-analog converter. Programming the reference voltage permits the digitizer to be used as a multiplier where the output of the digitizer is proportional to the product of the input to the digitizer and the inverse of the reference voltage.

Figure 3-25 is a block diagram of a sensor-digitizer system with continuous automatic calibration. Gating signals driven from the rotating sensor define the times at which space and the sensor housing are viewed. Sample-and-hold circuits present the voltages for space (ideally zero) at the end of the scale, and for the housing (usually warm) at the other end of the scale. The circuitry of Figure 3-25 will produce an all-zero code (minimum positive digital value) for the sensor output corresponding to space, and an all-ones code (maximum positive digital value) for the sensor output corresponding to the housing. The reference voltage can be scaled to make the sensor housing warmer or cooler than the temperature which should produce a full scale reading.

The above is only one example of continuous on-board sensor calibration. While it uses a more complex processing scheme on the spacecraft than the method currently in operational use, it provides a more easily useable calibration signal on the ground, and it is the recommended method for the unconstrained system. The obvious place for sensor calibration in a spacecraft system for operational users is on the spacecraft and not at the ground station.

#### 3.2.6.3 Ephemeris and Time Code

For purposes of geographic referencing, the ground station must be able to relate the sensor output continuously to satellite position and attitude. With an orbital control system maintaining a constant ground track, the need of ground stations for update of position data, once initial parameters are known, is quite low.

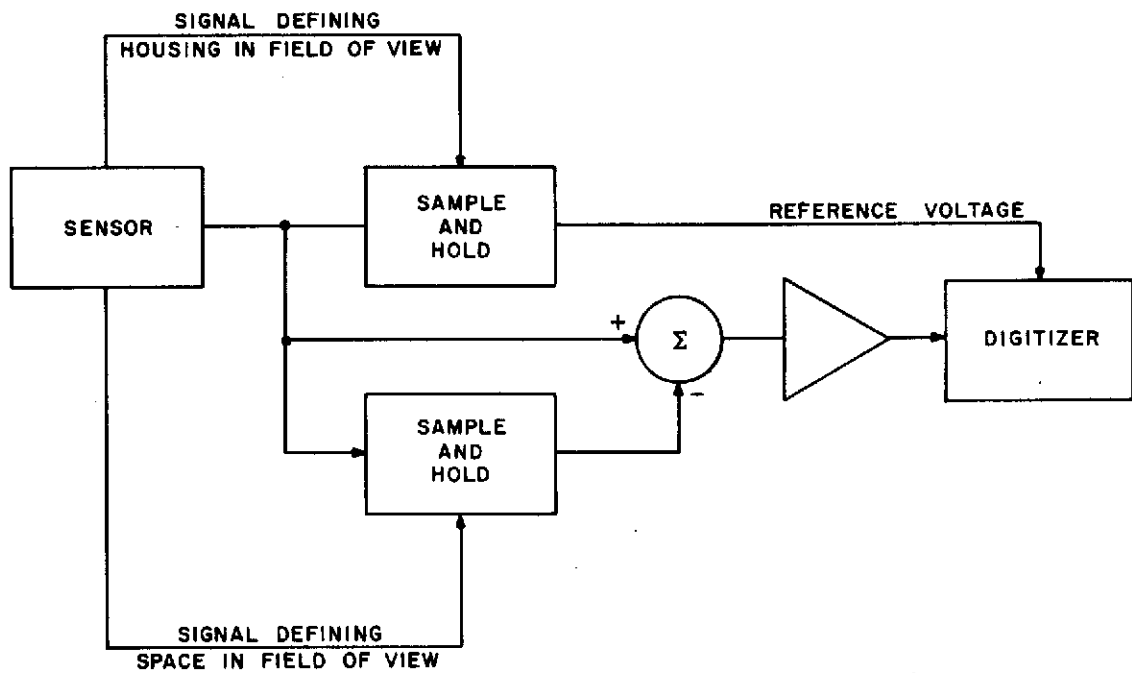

CIRCUITRY FOR AUTOMATIC CONTINUOUS CALIBRATION OF SENSOR/DIGITIZER

Figure 3-25



Orbit circularity is expected to be improved, with less altitude variation than the  $\pm 25$  nautical miles specified for ITOS D, so that altitude variation can be ignored. In confirmation of this expectation, the NOAA-2 spacecraft has an altitude variation from circularity of less than two nautical miles.

As discussed elsewhere in this report (3.2.6.4) knowledge of instantaneous position will require the use of a beacon transponder and the Goddard Range and Range Rate system to obtain vehicle position uncertainty of about one nautical mile.

The ground station need only know the exact time and longitude of the ascending node in order to establish accurate satellite position.

Time is a convenient measure of spacecraft progression in orbit. A usual input to APT ground gridding programs is scan time which in combination with the ephemeris and vehicle attitude data, permits a computation of the geographic location of the picture elements. A binary time code reference is generated on the ITOS spacecraft. While this type of code is simple to generate, its usefulness to the direct readout user is questionable. A need has been expressed for a time tic in the direct readout data.

Scanning radiometers do not have a "picture time" as such, but the principles are the same and each scan line should be time referenced to permit subsequent geographic referencing. A system which would minimize data manipulation on the ground is one which would include absolute time at periodic intervals in the data itself. If the time code were inserted at two minute intervals (approximately every  $3^\circ$  of latitude), any receiver of the data would find at least one time mark in his received data.

In addition, since the world uses a GMT reference for time, it would be consistent to convert the spacecraft time code to a settable GMT code. Thus, spacecraft time code would be directly relatable to spacecraft ephemeris. Either a time tic or time code reference could be transmitted in the analog signal and the time code could readily be transmitted in the digital direct readout data. The direct readout system will provide a GMT reference time code transmitted in the digital data system. Potentially more useful than a time mark would be a mark indicating the point at which the satellite subpoint path crosses an even numbered latitude line. This will be discussed in the section on gridding.

Also, relay of ephemeris data via the WEFAX link of the geostationary SMS can provide a daily report of equator crossing time and longitude, orbit inclination and spacecraft altitude data. The quantity of data is small and can be transmitted

once per day at a fixed time. Transmission teletype code and/or verbal form should all be compatible with the capabilities of this system.

#### 3.2.6.4 Gridding

A major point expressed by responders to the questionnaire was a desire for more accurate gridding. Chief contributors to inaccuracies in gridding in the past have been altitude variations, attitude uncertainties, picture time, or scan line time uncertainties, and poor ephemeris data. A satellite with the type of orbit control contemplated for TIROS N, carrying a precise clock, should have characteristics which will eliminate much of the problem.

Two aspects of the process of adding locating coordinate markers or grids to the radiometer data are the feasibility of obtaining the desired gridding accuracies and the allocation of processing functions between the spacecraft and the ground control center. The requirement for 18.5 km (10 n.m.) grid accuracy for 3.75 km (2 n.m.) resolution data is feasible; the requirement for a 1.8 km (1 n.m.) grid accuracy for 0.9 km (0.5 n.m.) resolution data requires a major improvement in the generation of ephemeris data and the determination of predictive attitude data for the meteorological systems.

Present tracking data is derived from an angle tracking system (i. e., Mini-track). More precise data can be obtained if the Goddard Range and Range Rate system is used with a transponder on the spacecraft. The necessary improvement in attitude prediction can only be obtained via the addition of a star tracker to the spacecraft equipment complement.

The development of small data processors using integrated circuit array techniques make a system of on-board processing worthy of more detailed evaluation. The trade-off in dividing processing functions between spacecraft and ground control centers is a trade-off of spacecraft hardware against similarly dedicated equipment on the ground and with consideration of communications link traffic.

The principle factors affecting the accuracy of the gridding are the accuracy of ephemeris data and the accuracy of knowledge of the spacecraft attitude. Time references, position of radiometer scan, and latitude-longitude references all can be established readily to the required accuracy. Spacecraft position can be predicted to an accuracy of 50 meters (0.003 n.m.) with a dedicated tracking network and a dedicated beacon or transponder on the spacecraft. An angle tracking system

of the type (minitrack) used with present meteorological systems can provide position data to an accuracy of 18.5 km (10 n.m.) indicates a position accuracy requirement of 1.8 km (1 n.m.) which can be obtained with a transponder and the Goddard Range and Range Rate system. The tracking information would be processed at the ground control center. The output of this processing function can be either a set of equations of spacecraft position as a function of time or a sequence of data points of position at specific times.

Spacecraft attitude is derived from the spacecraft dynamics subsystem. Processing this data can provide predictive data for the instantaneous values of roll, yaw, and pitch. These predictions will be accurate to  $0.3^\circ$ , as derived from the existing systems. These accuracies at a spacecraft altitude of 900 n.m. cause corresponding pointing position errors of 9 km (5 n.m.) at the nadir, 18 km (10 n.m.) at the point of contiguity, and 36 km (20 n.m.) at a zenith angle of  $65^\circ$ . An order of magnitude improvement in attitude prediction represents a major investment in spacecraft hardware (star tracker).

The 18.5 km (10 n.m.) accuracy for 3.7 km (2 n.m.) resolution data is feasible for data obtained to the point of contiguity; the greater accuracy of 1.8 km (1 n.m.) for 0.9 km (0.5 n.m.) resolution data can be met only with extensive improvements in the tracking (GR&R) and attitude sensing (star tracker) systems.

Figure 3-26 is a diagram of the data processing flow for grid generation. The spacecraft-ground interface can, conceivably, be placed anywhere in the diagram.

A "rectified" line of data from a scanning radiometer, where a fixed length increment of line data represents a fixed earth angle at any point on the line, has some interesting properties associated with the resulting imagery. Lines of constant latitude are independent of longitude. A single latitude line grid for a given altitude and orbit inclination (both of which will be accurately controlled by the OCS (Orbit Control System) can be "fitted" to any rectified data swath by sliding the grid parallel to the subpoint path in the image. Latitude along the subpoint path on the grid is a direct function of time after equator crossing. If the time of a scan line on the image data can be established, the latitude grid can be aligned accurately to the data (neglecting for the moment the effects of attitude error). Since the scan line is rectified, a single fixed longitude line grid can also be constructed which is aligned to the image data by sliding the grid along the subpoint path to accommodate time after equator crossing and then sliding the grid parallel to a second reference



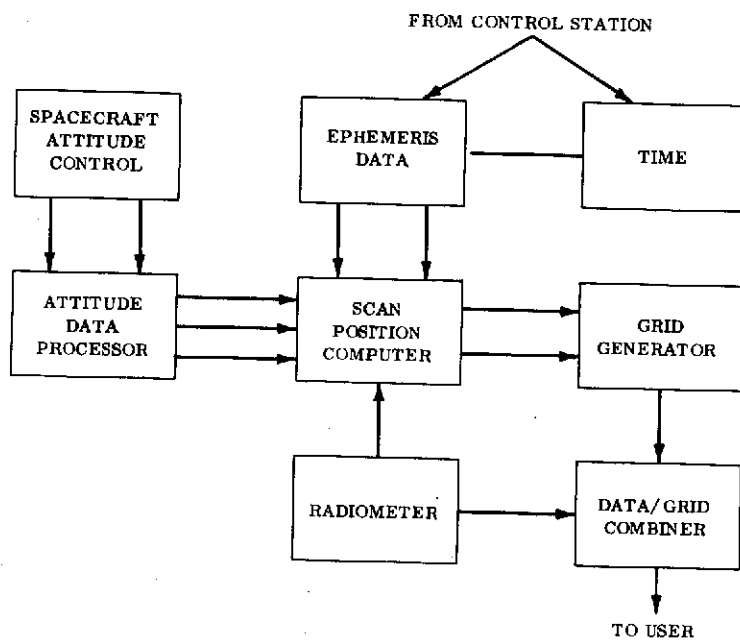

Figure 3-26 Grid Data Processing.

line to accommodate the longitude of the ascending node. This latter reference line forms an angle with the subpoint path of  $90^{\circ}$  minus the orbit inclination. Thus, a single set of one latitude grid and one longitude grid can be used to grid the data for any orbit. The requirement to compute a new grid disappears except for accommodation of satellite roll and pitch.

Roll and pitch introduce distortions in the imagery. For a small departure from zero pitch, most of the error can be removed by sliding a grid in the direction parallel to the subpoint track. A first order correction for roll deviations can be accomplished by sliding the grid perpendicular to the subpoint track, correcting the image displacement errors along the subpoint path but leaving one side of the image contracted and one side expanded. Yaw errors are the most disturbing, since no simple correction exists. Yaw errors by themselves cause no displacement of the sensor data at the nadir, but the error increases as the scanner field of view moves toward the sides of the swath.

If latitude markers appear at fixed intervals in the data itself, and if these markers are generated based on time and predicted vehicle pitch, the grid alignment process, either manual or digitally processed is trivial for the along-track direction. The crosstrack fitting is also easily accomplished with a knowledge of the orbit drift and vehicle roll. Both of these last parameters can be updated continuously from data included with the sensor data from the satellite.

A better and more complete solution to the ground station gridding problem is the insertion of a mark into the video data which defines both latitude and longitude.

A small cross, similar to the AVCS fiducial mark could be mixed into the data for points defined by fixed increments of latitude and longitude. The spacing should be sufficiently large that ambiguity is unlikely and sufficiently small to ensure that every receiver of data will see at least one mark in his image data. A longitude spacing of  $5^{\circ}$  is a convenient number, significantly larger than the maximum orbit drift anticipated for TIROS N. Figure 3-27 is a block diagram of the spacecraft processor for generation of the latitude-longitude fiducial mark.

A precision oscillator (clock pulse generator) drives a counter which delivers an output for each unit of time corresponding to the desired latitude increment. (A polar orbit is assumed for the example. For inclinations other than  $90^{\circ}$ , the counter output can be compensated for variation of latitude change with time.) A small on-board memory contains data which defines the scan line element number

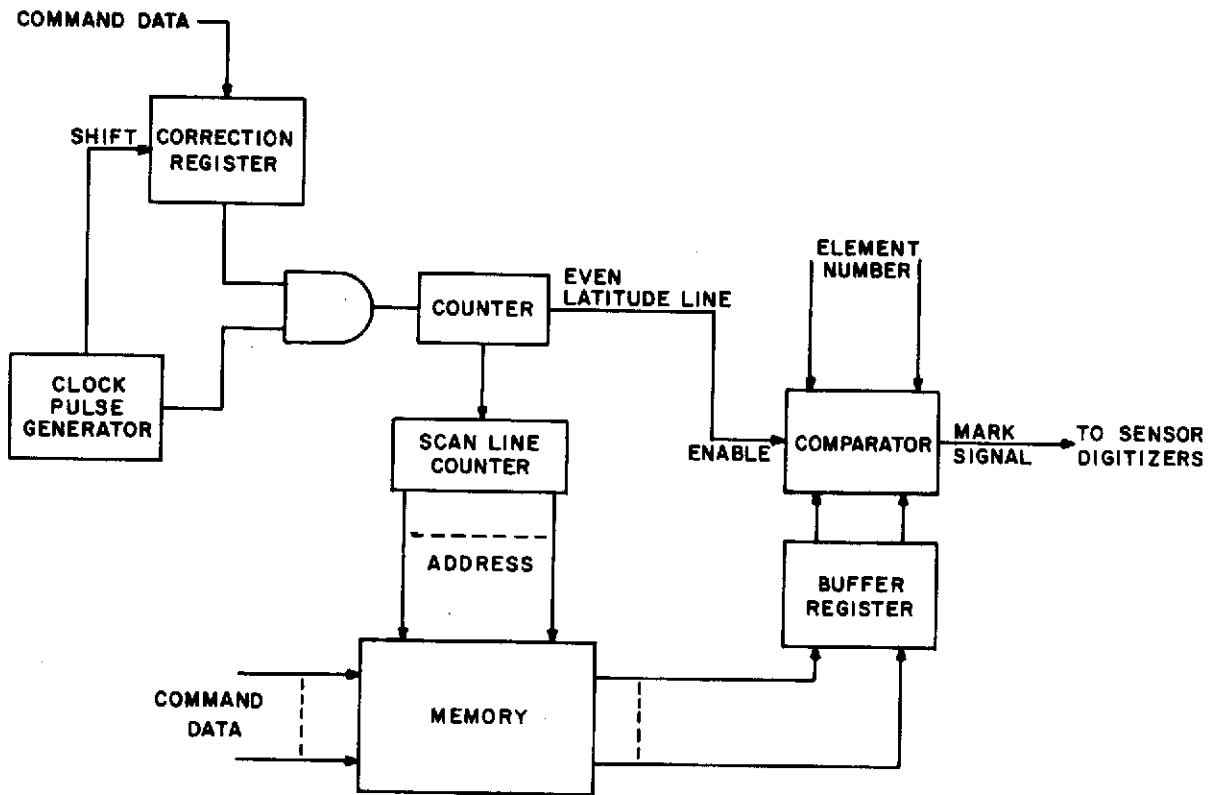

SPACECRAFT HARDWARE FOR  
GENERATION OF LAT/LONG "FIDUCIALS"

Figure 3-27

for each latitude/longitude fiducial to be generated. A scan line counter (indicative of latitude) provides a means of addressing the memory. (The scan element number for each new mark is a function of latitude). When the latitude increment counter generates an output, it enables a comparator which is "fired" when the line element count equals the value in the buffer register (most recently extracted from memory). A correction register, programmed by the CDA station, allows programming the time at which a latitude enable is generated by offsetting the counter. Thus, the times of the marks can be selected to match the times of traverse of the latitude lines. For a 2 degree latitude spacing and a 1/2 mile resolution, only eight bits would be required for the correction word from the CDA station. A longitude spacing of  $5^{\circ}$  would require 72 words if data were stored for  $360^{\circ}$  around the earth. However, considerations of symmetry suggest that data for only one quadrant need be stored, potentially reducing the requirement to 18 words.

The above is not intended to represent an optimum design for the fiducial generation task, but is included to demonstrate that relatively simple circuitry can be used on-board a satellite using an orbital control system and rectified scanner data, to completely unburden a ground station of complicated gridding operations.

The ground station with hard copy output has a precomputed grid on two overlays which an analyst fits to the fiducial marks. A ground station utilizing a display device for data analysis would have superimposed upon his display a real or video overlay which he could adjust. If the overlay were video and resident in a computer storage, he would have the facility to modify the X Y coordinates of the grid points to achieve the visual match in a manner identical to sliding an overlay over hard copy.

For the ultimate in gridding accuracy, ground stations equipped with digital computers should have the capability to compute new grids based on attitude data. This grid computation would be done prior to ground station acquisition of a vehicle and thus would not consume any computer time during the data receiving and display operations. Based on computer running times for APT grid generation on the antiquated CDC 160A at the Wallops Island and Fairbanks stations, an extrapolation of running times for modern mini-computers leaves little doubt that grid computation can be accomplished in the matter of a few minutes.

#### 3.2.6.5 Gamma Control

With a spacecraft self-calibrated sensor/digitizer and digital data trans-

mission to the ground station, an analyst should be able to control the output brightness/input radiance transfer function primarily for purposes of overcoming deficiencies in the display subsystem. Inexpensive display devices such as CRT's and facsimile receivers have far lesser gray scale capability than that required to display a 256 level image. This problem can be compensated for by gamma control. A secondary reason for gamma control is to facilitate the analysis of radiance data where the immediately available data covers much less than the full dynamic range of the sensor. For these reasons, the ground station operator should have a simple control for varying gamma, but it should be varied in such a fashion that absolute radiance level information is not lost in the process.

Assuming a computer aided display, it is a straightforward task to generate a sequence of data which would represent steadily increasing radiance values (similar to that produced by a step wedge). This sequence or gray scale can be added to the digital data organized for feeding the display in such a manner that the gray scale forms a vertical bar at the side of the displayed image. On a routine maintenance basis, the operator then adjusts the controls of the particular display device employed (such as brightness and contrast for a CRT) to obtain the best discrimination between the radiance levels of the gray scale.

A variety of transfer functions can be implemented by means of a computer program in order to permit an analyst to "expand" his display for a diminished radiance band or bands. The only penalty is computer processing time. However, one limited form of expansion requiring little hardware and imposing no time penalty is shown in concept in Figure 3-28. Potentiometer P1 produces a voltage which corresponds to radiance level or display brightness. The voltage produced by P1 is subtracted from the radiance voltage output from the D/A converter and the difference is amplified as determined by the amplifier A1 gain control. The amplified difference feeds a second amplifier A2 and the radiance level subtracted in A1 is added back. This has the effect of changing the brightness/radiance transfer function at any selected radiance level. Since the gray scale data is processed by the same circuitry, an analyst has a visual measure of the overall scale distortion. This approach to gamma control is inexpensive, overcomes some of the deficiencies of a limited gray scale display device, and could very likely aid an analyst in determining elements of a more sophisticated gamma control for future software implementation.

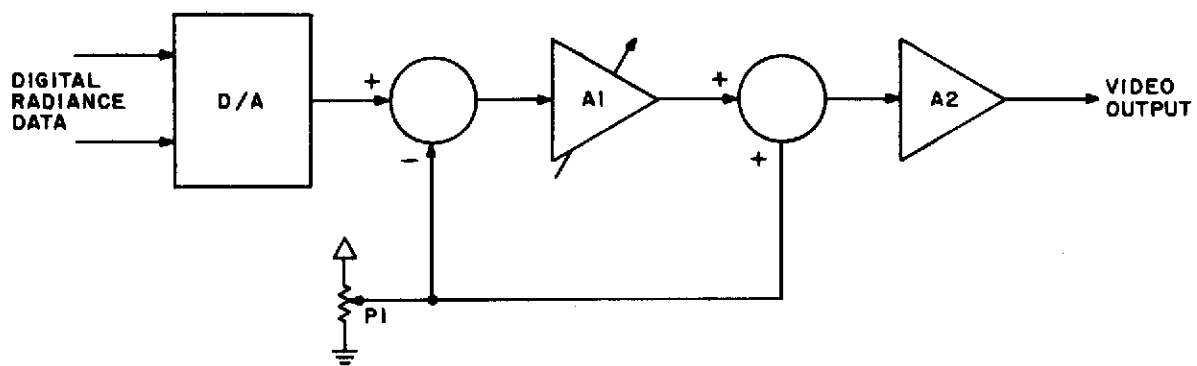

CIRCUIT FOR BRIGHTNESS/RADIANCE AMPLIFICATION

Figure 3-28

#### 3.2.6.6 Mapping

A small percentage of the questionnaire responders indicated an interest in mapping to facilitate correlation of the imaging with other data sources. While mapping is certainly possible with a mini-computer, the mapping operation would probably consume all of the computer time and leave it unavailable for other tasks (such as aiding the display, antenna pointing, etc.).

The benefits to be gained do not seem to warrant the complexity of the processing required and consequently, it will not be considered further in this report. One consideration should be borne in mind, however. A Direct Readout System, utilizing digital data and a computer-centered ground station, permits mapping to be done when algorithm and hardware developments make mapping feasible. Such developments are in progress, and mapping is feasible with the aid of large computers.

#### 3.2.6.7 Temperature and Reflectance Contouring

A great deal of interest has been expressed in temperature and reflectance contouring. Of particular interest is the possibility of superimposing brightness isolines on visible data for identifying certain cloud top temperatures and other viewed surfaces where the emissivity is known to a practical degree.

##### 3.2.6.7.1 Spacecraft

One technique for identifying cloud top temperatures is to include in the data, constant temperature contour lines. This inherently means, selecting a set of temperature values for which a unique symbol will be generated as the IR signal passes through the signal level corresponding to that temperature. With the assumption that  $5^{\circ}$  increments are required in the range  $280^{\circ}$  to  $300^{\circ}$ , some 7 symbols would be required, necessitating two dimensional symbols occupying several picture elements in each dimension.

The conclusion of this study is that for the limited precision provided, the obscuration of good data and the requirement of two dimensional processing, make this a function that can be more advantageously handled on the ground by those who desire such a presentation. More benefit is obtained from the simultaneous transmission of unobscured IR and Visible data.

### 3.2.6.7.2 Ground Station

Contouring, especially in the presence of noise, is a difficult task. For instance, when is a new contour line established? Certainly, a single data element crossing a threshold should not generate a new line unless an adjacent element also indicates a transition. Matching of contour lines from one scan line to the next presents a search and examine problem very consuming of time.

One simplified approach to contouring which bears investigation, involves establishing a number of radiance levels and generating a white (or black) pulse if an image element changes bands with respect to the previous radiance of the preceding image element. This is readily accomplished by comparing the most significant bits of succeeding image elements. For instance, taking the three most significant bits of the radiance values would establish eight levels for the sensor range. Nothing more is required than a digital computer for processing the data. The major difficulty with this approach is that lines could converge cross and diverge and no indication of the absolute value of the level appears in the display to permit the lines on either side of the crossing to be correlated. As a matter of fact, with two concentric circles, one would not know whether the inner circle represented a radiance increase or a radiance decrease. One could gain additional information by superimposing the transition pulses on top of the image, which then amounts to edge enhancement of the data. This technique would not permit isotherms to be superimposed on visible data.

The interest in contouring is a desire to be able to establish absolute levels at any point in the image. One attractive possibility which accomplished this without contouring, consists of establishing a radiance value below which the display goes black (gamma slicing). If the analyst has control of this radiance value, he can move the radiance value through the range of data and determine absolute levels for any point in the imagery. This assumes a visual display and the ability to rapidly modify the data. A CRT display is ideal. The subtraction would be done within the computer and the modified data loaded into the CRT refresh buffer. Thumbwheel switches interrogated by the computer permit an entirely digital process with no ambiguity or drift associated with the "slicing" level. A better solution from the human engineering viewpoint, would give the analyst a continuous control (potentiometer) and a visual readout of the selected level (digitizer).



### 3.2.6.8 Superposition of IR and Visible

The most obvious solution to temperature contouring, superposition of IR isotherms on visible data, is impractical as discussed above. However, the technique for establishing a set of edges representative of a single radiance value described above offers the possibility of temperature tagging the clouds in a visible picture. The radiance value threshold described above can be used to generate video pulses for the IR data whenever the threshold is traversed. If visible and IR data are simultaneously available to the processor, the video pulse representative of the IR threshold can be mixed into the visible signal by driving the visible reflectance value to full scale (or zero). Thus, an analyst could view a visible display with points (hopefully forming lines) representative of a single isotherm superimposed on the visible data. With control of the threshold, the analyst could change the isothermal points or lines, traverse the entire temperature range, and thus gain a measure of temperature for any point in the visible data. Since the correlation of data among radiometer channels is a distinctly desirable feature, it is strongly recommended that the data from two or more radiometer channels in the spacecraft be multiplexed on an element by element basis. A single 16-bit word could then be used to store both the IR radiance level and the visible reflectance value of an element from a two channel radiometer and no referencing errors could be possible. Any processing to rectify or reference the data geographically need be done only once, providing a significant time saving for ground processing.

### 3.2.7 Special Operating Functions

A number of requested improvements are well within the present state-of-the art capability of spacecraft technology. The question is then, are these improvements a benefit to all direct readout users, or is the data utilization for many of the direct users reduced as a result of the additional processing? Each of the following processing modifications is considered in summary fashion, indicating the recommendation for inclusion or rejection as part of the unconstrained system.

#### 3.2.7.1 Antenna Programming

The antenna gain required for a multichannel radiometer link will require that the antenna point accurately at the satellite to avoid signal loss. Tracking

receivers which could maintain accurate pointing are more expensive than the single channel receiver required to receive the data alone. Additionally, the feed system of the antenna must be more sophisticated to develop the required tracking signals. A computer-centered ground station offers the opportunity to point the antenna without tracking since the ephemeris for a TIROS N type vehicle equipped with a transponder will permit accurate satellite position knowledge. Two digital-to-analog converters and provision for shaft encoder readout, or a pair of digital-to-synchro converter channels enable a computer to drive the antenna system. A real time clock is also required in the computer. The azimuth and elevation values would be computed prior to the satellite pass, minimizing the time required for the computer to service the antenna drive system.

#### 3.2.7.2 Dynamic Gain Control

The variation in dynamic range of the data as a function of latitude and season of the year, led to a request to provide dynamic gain control. Two benefits would be derived from such a modification: 1) better use of available link signal to noise and 2) better use of dynamic range of displays.

The improvements in link signal-to-noise as a result of increases in effective radiated power (antenna improvement) obviate the need to adopt this approach to improve S/N. Perhaps a more powerful objection to such processing would be that those who wish to use the data quantitatively must now have a dynamically varying calibration system.

This refinement will not be part of the direct readout system.

#### 3.2.7.3 Data Storage and Dump

This requirement is based on the desire of a few users for extended area coverage. This function is one provided by the central processing station and should not be provided in the spacecraft because of the additional information load on the communication link. This requirement will be satisfied as the elapsed time between scene observation, processing at the central station, and redistribution via WEFAX and other distribution lines is reduced through the normal development and improvement of this system.

### 3.2.8 Special Problem Observations

#### 3.2.8.1 Ice and Snow Detection

There are two associated items on the requirements list; 1) discrimination between snow and clouds, and 2) detection of ice and snow through clouds. The former is possible in certain limited instances when information from the visible and from the far IR window regions are combined. Other spectral regions, namely, the  $1.6\mu\text{m}$  region and the microwave region, will yield additional distinguishing information. The only possibility for satisfaction of the latter requirement is use of the microwave region.

#### 3.2.8.2 Cloud/Snow Discrimination

The two common cases where the present system (VIS and far IR data) fails to distinguish between cloud and snow are: 1) high thin cirrus over snow or ice, and 2) low clouds in an inversion layer at higher latitudes. In both cases low resolution data from the visible channel offers little or no aid in the distinction of clouds and snow where the snow field is, or could be, widespread and continuous. The IR channel also fails, since in the former case the thin cirrus contributes little to the integrated outgoing radiance, and in the latter case because, due to the inversion, the cloud temperature might be as warm as, or warmer than, the surface. The detection of this latter case may be aided by including a channel at  $1.6\mu\text{m}$ . This region is essentially an atmospheric window with some  $\text{CO}_2$  absorption taking place. Thus, since  $\text{CO}_2$  is almost uniformly mixed in the atmosphere, the amount of reflected radiation would be related to the height of the cloud. As an example, at  $1.6\mu\text{m}$  a layer of clouds at 5,000 ft would appear "brighter" than the earth's surface covered with snow. A combination of data from the  $0.7\mu\text{m}$ ,  $1.6\mu\text{m}$  and  $11.5\mu\text{m}$  regions could provide the distinction between ice/snow and clouds in most cases. However, the addition of another channel puts additional burden on the already stressed radiometer design and communications link. An experiment containing a  $1.6\mu\text{m}$  channel is proposed for Nimbus G. Should this data prove satisfactory for evaluation of cirrus clouds, then consideration can be given to using this information in the direct readout.

### 3.2.8.3 Ice and Snow Detection Through Clouds

An apparent solution to this problem lies in the use of the microwave region. The use of this region for remote sensing has received much attention in recent years. Clouds have a varying effect on the microwave spectrum, with the greatest attenuation occurring at the shorter wavelengths. However, even at low frequencies, say 10 GHz, the attenuation due to rainfall and dense clouds would be significant. A further complication is introduced by the inverse proportionality between antenna diameter and frequency of operation for a given resolution. For example, at 907 n.m., to achieve a resolution of 2 n.m. in a passive microwave radiometer would require an antenna diameter of approximately 17 meters. Nimbus 5 carries an electrically scanned microwave radiometer operating at 19.35 GHz with an IFOV of  $2.8^\circ$  (or  $\approx 45$  n.m. resolution at 907 n.m.).

Thus, although the microwave region does offer some interesting possibilities, the state-of-the-art in both instrumentation and data interpretation is such that a passive microwave radiometer does not present itself as a likely candidate for inclusion in the DRS.

### 3.2.8.4 Conclusion

No feasible solution to the discrimination between ice and snow, nor the detection of ice and snow through clouds, is applicable to the unconstrained system. The discrimination between ice and snow is possible with the present system with VIS and far IR channels, except for 1) high thin cirrus over snow or ice and 2) low clouds in an inversion layer at higher latitudes.

## 3.3 Ground Functional Components

### 3.3.1 Receiving

A need for greater bandwidths than can be provided with a VHF link has been established above. These required greater bandwidths can be achieved at UHF. However, considering probably future requirements for even greater bandwidth suggests an S-band link. For this greater bandwidth requirement, the S-band antenna is comparatively less expensive and required changes to ground station equipment are minor. Thus, strong consideration should be given to an S-band link for the

Direct Readout System. Noise figure differences between available receivers at UHF and S-band are quite small, in the vicinity of 2 db. Sky noise at S-band is still negligible, and more noise will occur in the ground receiver due to internal noises than from sky noise, except in very expensive receivers not required for the direct-readout link.

Suggestions have been made that ground stations currently equipped with VHF receivers could use converters to receive UHF data. However, since the reason for moving to a higher frequency is to obtain a greater bandwidth, new receivers are required in any event. Hence, a strong recommendation is made for going directly to S-band for the multi-sensor channel Direct Readout System.

A strong argument has been made above for digital data transmission. In addition to the factors previously cited, Raga (1967) has shown that in cases where the maximum bandwidth is fixed, digital systems can transmit more information per unit time than analog systems. Accordingly, digital data transmission is assumed for the remainder of this report.

The assumed modulation is either Bi-phase or Quadra-phase CPSK (coherent phase shift keying). Receivers should be capable of handling either.

Table 3-7 shown a broad comparison of antenna systems for the two frequency ranges of interest (400 MHz and 1700 MHz), as well as the VHF frequency range (for reference).

In establishing approximate costs, advantage has been taken of the computer-centered ground station concept to eliminate costs usually associated with these antenna systems. The first advantage is that arising from an open loop tracking, with the pointing done from prestored azimuth and elevation values which are used to develop servo-error signals as a function of time. This eliminates the need for moving the feed (as in a conical scan system) or producing auxiliary azimuth and elevation error signals through multipoint feeds.

A second factor which can reduce cost is the realization that an open loop tracking system need have angular accuracies tight enough only to maintain the signal within the main lobe of the antenna pattern. A quarter of a degree per axis should be sufficient for the high gain S-band antennas.

Third, no rotary joints or slip rings are proposed since the antenna does not make multiple revolutions for a single satellite pass.

Since the direct readout ground station will often be located on islands subject to hurricane or typhoon type weather, and should work in the presence

TABLE 3-7

TYPICAL ANTENNA SYSTEMS FOR VHF, UHF, AND S-BAND

	<u>137 MHz</u>	<u>40 MHz</u>	<u>1700 MHz</u>	<u>1700 MHz</u>
Antenna Type	a) Disc/Rod Array b) Log Periodic	Quad Helix Array	5-foot Parabolic Dish	10-foot Parabolic Dish
Gain	a) 11 db b) 10 db	18 db	26 db	32 db
Pedestal	E1/Az Mount with Position Feedback	E1/Az Mount with Position Feedback	E1/Az Mount with Position Feedback	E1/Az Mount with Position Feedback
Auxiliary Equipment	None	Requires Radome for Accuracy with Wind Velocities Above 40MPH	Radome	Radome
Cost	a) \$12,000 b) \$13,000	\$3,000 without Radome	\$25,000	\$27,000

of wind speeds up to about 70 knots, a radome is recommended for use with a dish antenna. Once within a radome, the torque requirements for the ten-foot dish are only slightly different from those of the five-foot dish.

The Department of Health, Education and Welfare has issued an RFQ for 100-200 small receive-only satellite communications terminals operating in S-band. The satellite communications terminals, which will employ a ten-foot dish, are to be used with the ATS-F spacecraft to provide health and educational television and communications services to isolated communities in the Rocky Mountain states. The future availability of the antenna systems for this application may offer an attractively priced candidate for the meteorological direct readout ground station.

The cost of receivers for the ground station does not seem to be particularly sensitive to the frequency bands used, but is quite sensitive to noise figure requirements. A 400 MHz receiver with demodulator and a noise figure of 6 db costs approximately \$6,200. An S-band receiver with an 8 db noise figure is approximately \$7,400. A converter to modify the receiver from UHF to S-band costs about \$1,000.

### 3.3.2 Processing

A variety of minicomputers is available for the ground station tasks. The peripherals required include disc storage, a teletype (or some form of keyboard printer) for initialization and diagnostic purposes, and a high speed paper tape reader for program loading. The minicomputer should have 8K of core memory and a hardware multiply/divide. A general purpose interface is required for reception of video data and commands from the operator's control panel. Approximate costs for a complex as described above are:

16-bit minicomputer with arithmetic unit, 8K core and bootstrap loader	\$ 8,000
Real time clock	250
General Purpose Interface	1,000
Teletype and Interface	2,350
High Speed Reader and Interface	3,100
Disc Storage and Controller (24 million bits)	11,000
TOTAL	<u>\$ 25,700</u>

### 3.3.3 Display

A previous section contains a recommendation for a computer-aided CRT display. A facsimile unit should be retained in the ground station to: (a) provide a semi-permanent record allowing gross comparison of data from one day to the next, and (b) to indicate to the analyst the potential areas of high interest which can then be explored on the CRT display.

Several types of facsimile are available on the market, and break down into the following broad categories:

1. Thermal, or electrolytic, helical scan, special paper. These are inexpensive, but offer inferior quality reproduction, not good for photographic data or where good gray scale control is desired.
2. Dot Matrix (Gould, Verratile, Varian) - Only limited gray scale effects can be produced by controlling dot density. Not adequate for meteorological applications.
3. Photo (Muirhead): Photographic quality fax, using chemical developer that is temperature sensitive. Requires attention.

A quick glance at available facsimile devices does not show an attractive candidate for the Class 1 and Class 2 users. Hence, no recommendation as to type is made here. A budget of \$3,000 will be used for determination of total ground station cost.

### 3.4 Summary of Trade-Off Analyses

In this section we have defined the elements of an unconstrained system which meets feasible requirements as derived from a survey of the users of direct readout data.

Also, although we purport to present an unconstrained system, we were in fact constrained by our assumed definition of "feasible." A "feasible" spacecraft was assumed to be of the size and cost of present and planned meteorological satellites.

Each of the requirements was analyzed. Methods of meeting these requirements were considered and compared. Further, if the desired function could be performed in the spacecraft or in the ground station, a trade-off analysis was made to determine which was better. This analysis is summarized in Table 3-8, and includes recommendations.



TABLE 3-8  
Summary Analysis of Feasible Processing Requirements

RECTIFICATION

Spacecraft

Ground

Cross track rectification for scanning radiometer, non-linear scan or digital buffering of scan line with generation of "filler" samples, or non-linear digitization. Latter approach straightforward, small impact on spacecraft electronics. Especially benefits Class 3 user.

Cross track rectification of scanning radiometer data. Generation of digital "filler" samples or non-linear digitization of analog data for digital to analog converter. First approach consuming of computer time, latter degrades data.

Recommendation: Spacecraft processing.

GRIDDING

Feasible on spacecraft with small processor, 80,000 bit memory and updata link. Grids precomputed and stored in satellite after transmission from CDA station. Especially benefits Class 3 user.

Rectified SR data easily gridded on ground if time or geographic "reference points" mixed into video data. One set of one latitude grid and one longitude grid for any given altitude and orbit inclination. Offers potential to "fit" coastlines to data for maximum accuracy but few coastlines appear.

Recommendation: No compelling reasons for either spacecraft or ground processing, hence, ground processing recommended to avoid investment in spacecraft system.

TABLE 3-8 (cont.)

DIGITIZATION

Spacecraft

Digitizing of sensor data permits retention of sensor accuracy. No degradation from data link or ground recording. More resistant to EMI. No requirements for maintaining precise linearity of data link components. In addition, offers all benefits listed at right.

Ground

Permits easier manipulation of data compared to analog. Allows use of inexpensive minicomputers, avoids degradation of data in recording process.

Recommendation: Digitize all sensor data on spacecraft.

CALIBRATION

Automatic "end point" calibration of sensor digitized output possible using variable offset and digitizer in ratio-meter mode. Offset and scaling programmed to achieve constant digital numbers for one low and one high reference radiance value per channel. Especially beneficial to Class 3 users since data is immediately ready for analysis when received.

Reference radiance values in data can be used to calibrate sensor channel. Requires flexible data processor to apply correction factors to data.

Recommendation: Spacecraft Calibration.

IR PROCESSING

Combining of IR and visible data is only IR processing type offering benefits to receiver of data. Requires contouring of IR isotherms. Extremely complicated processing.

Ground processing offers maximum flexibility, evolution of contour packages. Iso-brightness for one level easily superimposed on visible data.

Recommendation: Ground Processing.

SOUNDER PROCESSING

VTPR processing currently requires too much processor capability for spacecraft processing.

Possible on ground with large computer.

Recommendation: Feasible only on ground.

## 4. DEVELOPMENT OF THE SPACECRAFT SYSTEM

In this section the development of a spacecraft system designed to meet the stated user requirements to the extent feasible is presented and analysed. From this the recommended system is obtained. The recommended system is presented in Section 5.

### 4.1 Summary of the Feasible System

Transmission of this data requires receiving equipment which ranges from the current 137 MHz receiving equipment with minor rate modifications to 400 MHz and S-band receiving facilities with digital processing capability and associated displays.

The spacecraft evolution is a four-step process, which includes the following changes at the indicated step:

#### Step 1

Increased effective radiated power (new antenna); Digital Delay for interlace of visible data (replacing tape recorder); Sounder Data on Beacon Full Time.

#### Step 2

Constant resolution 2 n.m., 2 channel analog data on 137 MHz carrier. Digital Data Transmission of 400 MHz 2 n.m. constant resolution data and 1700 MHz, 0.5 n.m. sub-point data. Use VHRR as source of all Radiometer data (no SR).

#### Step 3

Improved instrument with 4 spectral channels, digital data transmitted at 400 MHz, 2 n.m. constant resolution, and 1700 MHz 0.5 n.m. sub-point data (6.7  $\mu$ m data at 2 n.m. resolution) orbit with constant ground track (orbit adjust system).

#### Step 4

This option will provide restricted coverage, 600 n.m. square, 1 n.m. constant resolution data at S-band, in place of the 0.5 n.m. sub-point data. This option requires a scanning radiometer with

a sub-point resolution of 0.25 n.m. Such an instrument would have to be developed.

#### 4.1.1 User Requirements as Related to Station Size

The users were categorized by station size in Section 2 as Class 1 Users, Class 2 Users, and Class 3 Users.

##### 4.1.1.1 Class 1 User

The Class 1 user services a region of smaller subscribers and has at hand substantial receiving capability at 400 MHz/1700 MHz and a large computing facility which can manipulate large quantities of data.

##### 4.1.1.2 Class 2 User

The medium user is assumed to have the resources to purchase receiving facilities at 400 MHz/1700 MHz (equivalent to an 8-foot to 10-foot dish) and a mini-computer. The data of interest to him is data with high resolution (0.25 n.m.) of restricted coverage area (500 n.m. square) and updated at frequent intervals (1/2 hour). His requirements are the most difficult to satisfy. The data will be received in digital form to retain the S/N characteristics of the sensor. He will also need, and be able to use, data from 4 spectral channels.

##### 4.1.1.3 Class 3 User

The small user is constrained either by resources of capital or real estate. His facilities represent a minimum capability for receiving and processing data. The system provides improved data characteristics for this user.

#### 4.1.2 Relation between the Feasible System and the User Requirements

Table 4-1 relates the user requirements to the output of the feasible system. While the stated needs of the small and medium user do not appear to be satisfied in resolution or interval between observations, a considerable improvement in data is provided for the small user. His present resolution is variable ranging from 2 x 4 n.m. at sub-point to 8 x 7 n.m. at 65°Z in the visible and

Requirement						Feasible System Capabilities Resolution				
Resolution	Period Between Observations	Spectra	Format	Link	Resolution	Period Between Observations	Spectra	Format	Link	
Class 3 User	Unspec	Unspec	VIS IR	Unspec	Unspec	2 n.m.	6 hrs.	VIS IR	Analog	137 MHz
Class 2 User	1/2 n.m.	1/2 hr.	VIS IR WV Near-IR	Unspec	Unspec	* 2 n.m.	6 hrs.	VIS IR WV Near-IR	Digital	$\frac{400}{1700}$
Class 1 User	2 n.m.	6 hrs.	VIS IR WV Near-IR	Unspec	Unspec	* 0.5 n.m. Sub-point	6 hrs.	VIS IR WV Near-IR	Digital	1700

\* One n.m. constant resolution in proposed 4th step of development.

TABLE 4-1

User Requirements vs. Feasible System

4 x 4 n.m. at subpoint to 16 x 7 at 65°Z in the infrared. This system provides a constant 2 x 2 n.m. resolution across the scan with an improvement in S/N and margin of 5 db.

The medium user's requirements are not met completely either. But the data provided is in digital form which permits a minimization of the degradation of the sensor S/N, and four spectral channels of data are provided.

The fact that the large user's requirements are over subscribed is merely a reiteration of that old economic kernel of wisdom, "the more you pay, the more you get."

#### 4.1.3 Evolution of the System

##### Step 1

The system is developed through a four-step evolutionary process. Step one provides an increase of 5.5 db in "worst case" EIRP and an improved delayed visible signal. The former is achieved with an improved antenna; the latter by using a digital delay in place of the recorder. The essential data characteristics of the ITOS-D (NOAA-2) satellite are retained. Four n.m. by 4 n.m. sub-point resolution data from IR and 2 n.m. by 4 n.m. data from visible sensors is transmitted on a 137 MHz carrier and 0.5 n.m., sub-point resolution data from IR and visible sensors are transmitted on a 1697 MHz carrier.

##### Step 2

At step 2 in the evolution, the data on the 137 MHz link is a constant 2 n.m. resolution visible and IR signal with geometric correction in the scan direction. The scan rate is 120 lines per minute. A 400 MHz digital data link is added which provides the same coverage and resolution as the 137 MHz link, but since it is digital, retains the signal-to-noise characteristics of the sensor. The S-band link will carry the digitized output of the two channels of the radiometer. The unprocessed sensor output is a 0.5 n.m. sub-point signal at a scan rate of 360 rpm. All data is derived from the VHRR, thus deleting the need for the 48 rpm Scanning Radiometer. The ground equipment for the 137 MHz link is step 2 is unchanged except for the

shift to a 120 rpm line rate and the change in aspect ratio due to the stretching of the data.

The 400 MHz system requires a ground antenna with a gain of 9 db, modest tracking capability, a phase-locked receiver with a noise figure of 5.5 db, a bi-phase demodulator, a digital processor, and an associated display.

The S-band receiving complex retains the 10-foot, 32 db antenna and tracking pedestal, but now requires a phase-locked receiver, bi-phase demodulator, digital processor, and display.

The principal improvements in step 2 are: 1) Constant 2 n.m. by 1.5 n.m. resolution for IR and visible data. (Previous data was 4 by 4 at sub-point to 16 by 7 at 65° zenith), 2) Digital data at 400 MHz, and 3) Digital data on the S-band link.

### Step 3

The space system now consists of two satellites at 907 n.m. giving coverage at six hour intervals. The characteristics of the 137 MHz link are unchanged at step 3. The 400 MHz link contains 4 channels of sensor data, visible, near IR, water vapor, and IR. The data quadra-phase modulates the carrier, thus no increase in receiver bandwidth is required, but the received carrier-to-noise "threshold" increases 3 db. Therefore, in the worst case link, either a lower noise figure receiver or a higher gain antenna is needed to provide a carrier-to-noise ratio which will yield an error rate of one in  $10^5$ . A quadra-phase demodulator is required plus expanded digital processing and display capability.

The S-band link will transmit the digitized output of the four channels of a new radiometer, which has a 0.5 n.m. sub-point resolution in three spectral channels and 2 n.m. sub-point resolution in the water vapor channel. The scan rate of the radiometer is 360 rpm. In the worst case, i.e., 5 degree antenna elevation, the received power is deficient by 0.9 db to maintain an error rate of one in  $10^5$ .

This system provides the Class 1 station with four channels of digital data derived from the 0.5 n.m. sub-point radiometer. The data can

be processed as required at the central processing center or as needed by its smaller subscribers.

The Class 2 station will receive 2 n.m. constant resolution digital data from the four sensor channels. An option providing higher resolution, restricted coverage, will be described later.

The Class 3 station will continue to receive analog data, but it will have been upgraded to remove scan distortion and provide constant resolution of 2 n.m. for both channels at 120 rpm.

#### 4.1.3.1 Step 1 (One Spacecraft, Altitude 790 n.m.)

Two of the three elements of the step one improvement have an effect on the signal-to-noise of the demodulated signal. The performance of the digital delay network is superior to the tape recorder both in terms of signal-to-noise ratio and element position jitter. The improved antenna produces a 5.5 db increase in "worst case" EIRP. The revised 137 MHz link summary is shown in Table 4-2. The system S/N for the nominal and worst cases for this system and the ITOS-D system are tabulated in Table 4-3. Shown in the table are the S/N of the digital delay network (57 db) and the S/N of the tape recorder (40 db) and the 7.4 db improvement in the RF link due to the antenna change. The net result is an increase in S/N ranging from 1.7 db for the nominal case IR to 7.3 db for the nominal case visible channel. The proposed antenna characteristics are shown in Figure 4-1.

Figure 4-2 illustrates the substitution of the digital delay for the tape recorder. The storage capacity of the delay network is determined by the visible video baseband (900 Hz), 2.5 samples per cycle, the number of bits per sample (8 bits), and the time delay required (0.625 seconds). The capacity, based on these numbers, is 1407 words and 11,256 bits. Such an array made of either a P-MOS register or a C-MOS read/write memory would require two boards and 1 to 2 watts. The ITOS-D system allows radiometer jitter of 200  $\mu$ seconds. The latter jitter will be eliminated by the digital delay network where the jitter can readily be made less than 10  $\mu$ seconds with appropriate radiometer/converter synchronization.

The third element of the step one modification is the addition of the real-time transmission of VTPR digital data on the ITOS Beacon link. The ITOS system now transmits attitude and telemetry data on subcarriers of 2.3 kHz and



TABLE 4-2

## VHF LINK CALCULATION STEP 1

	<u>Nominal</u>		<u>Worst Case</u>	
S/C				
Transmitter Power	6.3 w	-8.0 dbw	5 w	+7.0 dbw
Losses		-1.3 db		-1.8 db
Antenna Gain	48°	+3.0 db	55°	+2.0 db
Ellipticity	48°	-1.5 db		-2.0 db
Path Loss	1540 n. m.		2190 n. m.	
	20° elev.	-144.6 db	5° elev.	-147.7 db
Ground				
Antenna Gain		+12.5 db		+12.5 db
Circuit Losses		-1.0 db		-1.0 db
Received Power		-124.9 dbw		-131.0 dbw
Receiver IF BW	50 kHz		50 kHz	
System Noise Temperature	1692°K		1692°K	
Noise Power		-149.3 dbw		-149.3 dbw
C/N		24.4 db		18.3 db
Margin above 10 db Threshold		14.4 db		8.3 db
Demodulated S/N				
(p-p/rms)	450 Hz	53.0 db	450Hz	45.9 db
	900 Hz	49.7 db	900 Hz	42.6 db

TABLE 4-3

ITOS-DOVERALL SYSTEM S/N OF REAL-TIME  
SR DATA AT LOCAL APTGS

Contributing Element	Peak-to-Peak Video <sup>*</sup> /rms Noise			
	IR Data <sup>**</sup>		Visible Data <sup>***</sup>	
	Worst Case	Nominal	Worst Case	Nominal
SR Sensor	45.0 db	49.0 db	44.0 db	66.0 db
SR Processor	47.0 db	52.0 db	47.0 db	52.0 db
SR Recorder (Tape Recorder Delay)	N/A	N/A	36.0 db	40.0 db
VHF RT Transmitter	47.0 db	52.0 db	47.0 db	52.0 db
RF Link	37.5 db	45.6 db	34.4 db	42.4 db
Ground Receiver (est.)	47.0 db	52.0 db	47.0 db	52.0 db
Demod (est.)	47.0 db	52.0 db	47.0 db	52.0 db
Overall System S/N				
Normal Mode (IR+VIS)	35.0 db	42.0 db	31.0 db	37.0 db

STEP 1 IMPROVEMENTOVERALL SYSTEM S/N OF REAL-TIME  
SR DATA AT LOCAL APTGS

Contributing Element	Peak-to-Peak Video <sup>*</sup> /rms Noise			
	IR Data <sup>**</sup>		Visible Data <sup>***</sup>	
	Worst Case	Nominal	Worst Case	Nominal
SR Sensor	45.0 db	49.0 db	44.0 db	66.0 db
SR Processor	47.0 db	52.0 db	47.0 db	52.0 db
Digital Delay (Quantization Noise)	N/A	N/A	57.0 db	57.0 db
VHF RT Transmitter	47.0 db	52.0 db	47.0 db	52.0 db
RF Link (Cylindrical Antenna)	45.9 db	53.0 db	42.6 db	49.7 db
Ground Receiver (est.)	47.0 db	52.0 db	47.0 db	52.0 db
Demod (est.)	47.0 db	52.0 db	47.0 db	52.0 db
Overall System S/N				
Normal Mode (IR+VIS)	38.4 db	43.7 db	37.6 db	44.3 db

\* Video dynamic range (Increase S/N numbers by +2.0 db if referenced to sync pulse amplitude).

\*\* 450 Hz baseband bandwidth.

\*\*\* 900 Hz baseband bandwidth.

Note: 1. Worst case uses a 5° elevation angle  
2. Nominal case uses a 20° elevation angle.

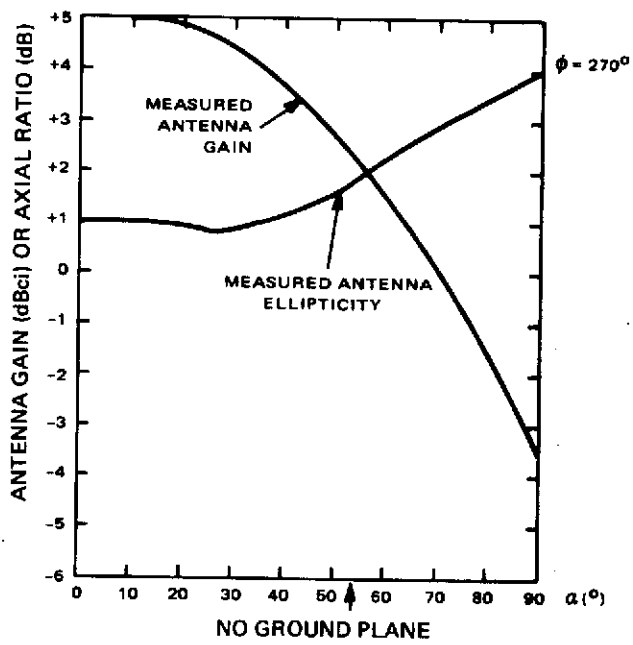

Figure 4-1 Cylindrical Antenna Gain.

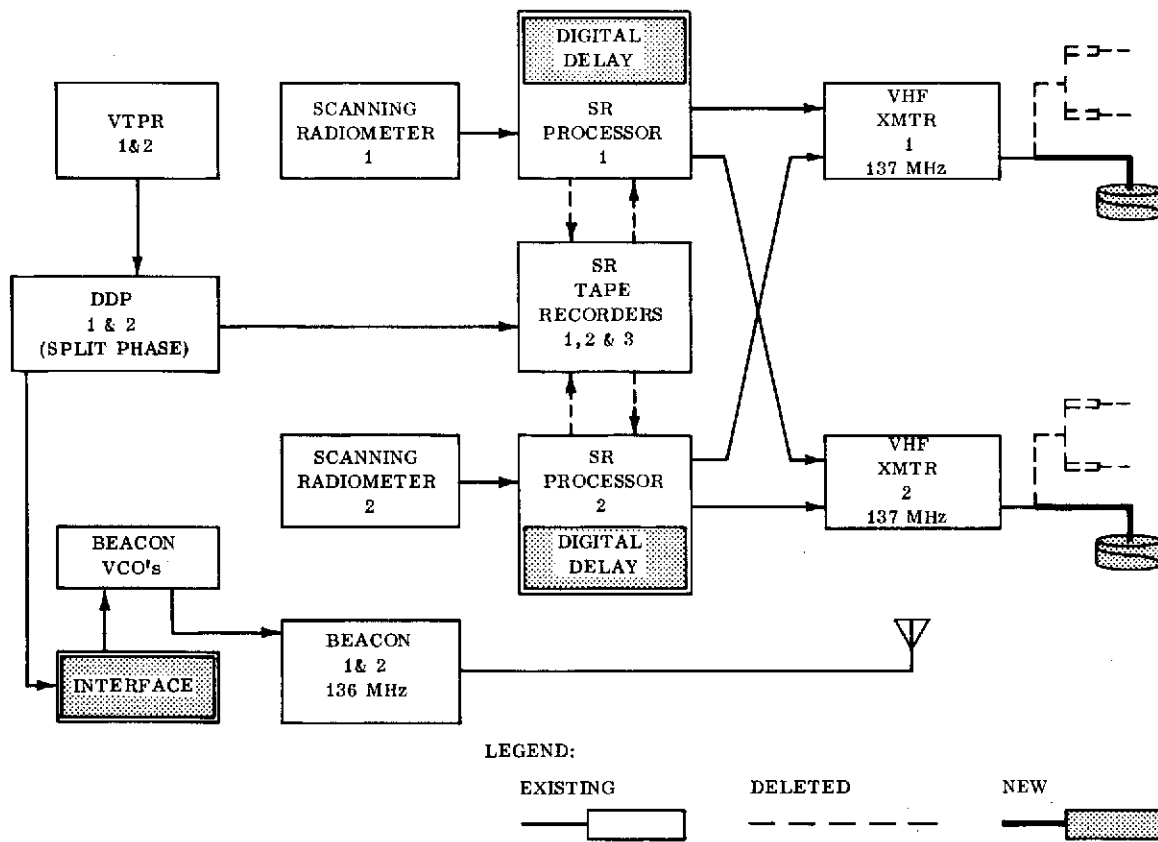

Figure 4-2 ITOS Direct Readout Modification, Step 1.

3.9 kHz on the beacon. The split phase digital data at a 512 bps rate is added to these signals. The digital data contains spacecraft telemetry data, Solar Proton Monitor data, and VTPR data. Table 4-3a indicates the performance of the beacon link with respect to the digital data.

#### 4.1.3.2 Step 2 (One Spacecraft, Altitude 790 n.m.)

The second step in the evolution will provide constant 2 n.m. resolution, geometrically corrected data in both visible and IR spectra. The data will be in analog form on the 137 MHz link and digital form on the 400 MHz link (0.5 n.m., sub-point, digitized data will be present on the S-band link). Figure 4-3 shows the block diagram of the spacecraft processing needed to accomplish this. The radiometer operates at 360 rpm.

The 30 kHz infrared and visible data from the radiometer is sampled at an 85 kHz samples per second rate. The bit rate per channel out of the A-D converter (8 bits per sample) is 600 kilobits per second. Only the data between  $65^{\circ}$  zenith angles will be processed and transmitted. This minimizes storage needs and conserves RF bandwidth.

The time to scan between  $65^{\circ}$  zenith angles at a 360 rpm rate is 46.3 milliseconds. Thus, the number of words which must be stored is 3,460 words per scan per channel or 27,680 bits per scan per channel. To accomplish the geometric correction and element averaging for the approximation of a 1.5 n.m. signal, processing and storage must be provided for 865 words per channel.

The data for the S-band transmission is buffered, and is formatted to interleave infrared and visible words and provide a line sync. Since the line rate is 360 lpm, and only data between  $65^{\circ}$  zenith angles is to be transmitted, the bit rate for the composite channel will be 416 kilobits per second. The RF bandwidth required to transmit this data reliably is 1.4 MHz, allowing for a baseband of 582 kHz and 178 kHz for doppler and instabilities. Table 4-4 summarizes the link performance for the indicated assumed system parameters. The results indicate adequate performance with a 5 watt spacecraft transmitter.

The 2 n.m. resolution data is obtained by averaging the data in matrices which vary from 4 by 3 at the sub-point to 1 by 3 at  $65^{\circ}$  zenith. The words from the IR and VIS channels are interleaved on a word by word basis. The data is read out at a line rate of 120 lpm. The bit rate allowing for sync, etc., is 34,500

TABLE 4-3A

Beacon Transponder Link S/N

Received E/No	14.7 db
1/4 watt S/C Transmitter	
Nominal S/C Antenna 0 db	
5.5 Meter-Backfire Ground Antenna	
Required E/No for $P_e = 10^{-6}$	12.5 db
(Includes 2 db Detection Loss)	
	<hr/>
Margin	2.2 db

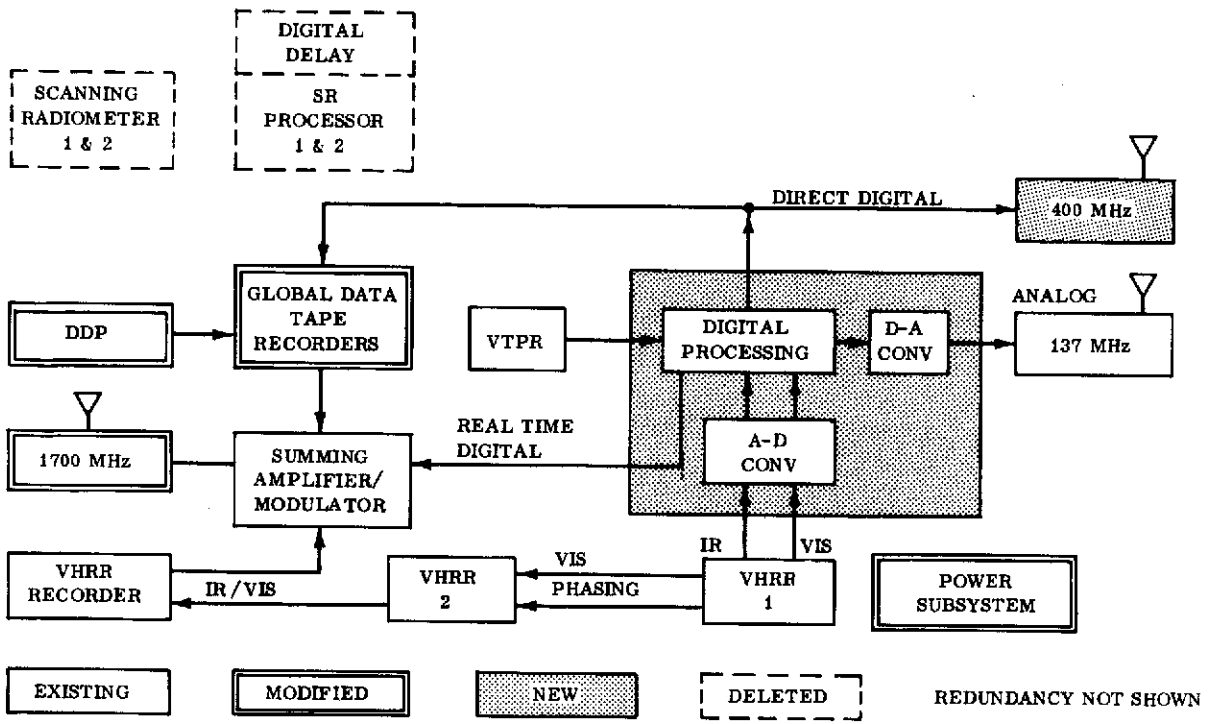

Figure 4-3 ITOS Direct Readout Modification, Step 2

TABLE 4-4  
S-BAND LINK STEP 2

	<u>2 Channel Digital</u>		<u>0.5 n.m. Sub-Point</u>	
	<u>Nominal</u>		<u>Worst Case</u>	
Spacecraft				
Transmitter	6 w	7.8 dbw	5 w	7 dbw
Losses		-0.6 db		-0.7 db
Antenna Gain		3.0 db		1.9 db
Polarization Loss		0.0 db		-0.6 db
Path Loss	1540 n.m. 20° elev.	-166.0 db	2190 n.m. 5° elev.	-169.6 db
Ground				
Antenna Gain	10'	3.2 db	10'	32.0 db
Receiver Losses		-1.0 db		-1.0 db
Received Power		-125.4 dbw		-131.0 dbw
Receiver BW	1.4 MHz		1.4 MHz	
System Noise Temperature	400°K		400°K	
Noise Spectral Density		-202.6 dbw/Hz		-202.6 dbw/Hz
Bit Rate	420KB/sec	56.3 db-BPS	420KB/sec.	56.3 db-BPS
Received E/No		20.9 db		15.3 db
Required E/No		12.5 db		12.5 db
Margin		8.4 db		2.8 db



bits per second. The baseband width required is 48,500 Hz. Allowing 44 Hz for doppler and instabilities, the required bandwidth is 150 kHz. Table 4-5 shows the link performance for a 10 watt s/c transmitter and a 16 db ground antenna. Adequate performance is obtained in the worst case.

The same data that was averaged for the 400 MHz link will be converted to an analog signal and time multiplexed on a scan by scan basis to provide the corresponding constant 2 n.m. resolution, 120 lpm, geometrically corrected analog signal for the 137 MHz link performance shown in Table 4-6.

The addition of the 400 MHz transmitter and the digital processing, and the deletion of the scanning radiometers result in a net increase in spacecraft power dissipation of 25 watts and a reduction in weight of 9.3 pounds (see Table 4-7a). The ITOS-D series spacecraft satisfied energy balance requirements at 60° sun angle and beginning-of-life (BOL) component performance. After six months in orbit, reduction of the real-time S-band operations must be programmed at sun angles of 55° and higher. The 25 watt increase in dissipation would require reduction of S-band operations at sun angles higher than 56° at BOL and 51° after six months in orbit.

Substitution of a PWM regulator for the series regulator would extend the sun angle for which no programming is required to 59° at BOL and 54° after six months in orbit. Additional solar array also can be added to enhance performance at the higher sun angles.

TABLE 4-7A  
Step 2 Weight & Power Changes

	<u>Power</u>	<u>Weight</u>
400 MHz Transmitter	+35 watts	+12 lbs (redundant units)
Antennas & Cables		+12 lbs (redundant units)
Digital Processing	+ 4 watts	+10 lbs (redundant units)
	<u>+39 watts</u>	<u>+32 lbs</u>
Scanning Radiometer & Processor	<u>-14 watts</u>	<u>-43.3 lbs</u>
Net Change	<u>+25 watts</u>	<u>- 9.3 lbs</u>

As an alternate for step 2 evolution, the 2 n.m. constant resolution digital data could be transmitted on the S-band link, replacing the 0.5 n.m. sub-point resolution data. Table 4-7b indicates excellent performance for the worst case

TABLE 4-5  
400 MHz LINK STEP 2

	<u>2 Channel Digital</u>		<u>2 n.m. Constant</u>	
		<u>Nominal</u>		<u>Worst Case</u>
Spacecraft				
Transmitter	12.5w	+11.0 db	10w	10.0 dbw
Losses		-1.5 db		-1.5 db
Antenna Gain	48 <sup>o</sup> (Nadir)	3.0 db	55 <sup>o</sup> (Nadir)	2.0 db
Ellipticity		-1.5 db		-2.0 db
Path Loss	1540 n.m.	-154.0 db	2190 n.m.	-157.0 db
Ground	20 <sup>o</sup> elev.		5 <sup>o</sup> elev.	
Antenna Gain log-periodic		9.0 db		9.0 db
Circuit Losses		-1.0 db		-1.0 db
Received Power		-135.0 dbw		-140.5 dbw
System Spectral Density	1000 <sup>o</sup> K	-198.6 dbw/Hz	1000 <sup>o</sup> K	-198.6 dbw/Hz
Bit Rate	35KB/sec	45.5 db-BPS	35KB/sec	45.5 db-BPS
Received E/No		19.1 db		12.6 db
Required E/No		12.5 db		12.5 db
Margin		5.6 db		0.1 db

TABLE 4-6  
137 MHz LINK STEP 2

	<u>2 Channel Analog</u>		<u>2 n.m. Constant</u>	
		<u>Nominal</u>		<u>Worst Case</u>
Spacecraft				
Transmitter	6.3 w	+8.0 db	5 w	+7.0 dbw
Losses		-1.3 db		-1.8 db
Antenna Gain		3.0 db		2.0 db
Ellipticity		-1.5 db		-2.0 db
Path Loss	1540 n.m.	-144.6 db	2190 n.m.	-143.7 db
Ground	20° elev.		5° elev.	
Antenna Gain		+12.5 db		+12.5 db
Losses		-1.0 db		-1.0 db
Received Power		-127.1 dbw		-132.6 dbw
Receiver IF BW	50 kHz			
System Noise Temp.	1692°K			
Noise Power		-149.3 dbw		-149.3 dbw
C/N		24.4 db		18.3 db
C/N Required		10.0 db		10 db
Margin		14.4 db		8.3 db
AM Subcarrier S/N (rms/rms) Sign. BW	1570 Hz	48.8 db	1570 Hz	41.4 db
Demodulates S/N (p-p/rms) Sign. BW	1570 Hz	51.4 db	1570 Hz	44.0 db

TABLE 4-7B  
S-BAND LINK ALTERNATE STEP 2  
2 CHANNEL DIGITAL

	<u>Nominal</u>		<u>Worst Case</u>	
<b>Spacecraft</b>				
Transmitter	6w	7.8 dbw	5 w	7.0 dbw
Losses		-0.6 db		-0.7 db
Antenna Gain		3.0 db		1.9 db
Polarization Loss		0.0 db		-0.6 db
Path Loss	1540 n.m. 20° elev.	-166.6 db	2190 n.m. 5° elev.	-169.6 db
<b>Ground</b>				
Antenna Gain	5'	26.0 db	5'	26.0 db
Receiver Losses		-1.0 db		-1.0 db
Received Power		-130.4 dbw		-136.4 dbw
Noise Spectral Density		-202.6 dbw/Hz		-202.6 dbw/Hz
Bit Rate	35K-BPS	45.5 db-BPS	35K-BPS	45.5 db-BPS
Received E/No		25.2 db		20.7 db
Required E/No		12.5 db		12.5 db
Margin		12.7 db		8.2 db

link. The impact on other subsystems on the spacecraft is all positive. Table 4-7c summarized the power and weight changes for alternative step 2.

TABLE 4-7C  
Alternate Step 2 Weight and Power Changes

	<u>Power</u>	<u>Weight</u>	
Digital Processor	+45 watts	+10 lbs	(redundant units)
Scanning Radiometer & Processor	-14 watts	-43.3 lbs	(redundant units)
Net Change	-10 watts	-33.3 lbs	

4.1.3.3 Step 3 (Two Spacecraft with Orbit Adjust System, at 907 n.m.)

A four-channel radiometer is the primary sensor for the third phase of the evolution of the system. The four channels are visible (0.5 n.m. sub-point), near-IR (0.5 n.m. sub-point), water vapor (2 n.m. sub-point) and IR (0.5 n.m. sub-point). The scan rate is 360 lpm.

Figure 4-4 is the block diagram for step 3. The characteristics of the data transmitted on the 137 MHz carrier are unchanged from step 2. Further improvement of the signal is constrained by the 50 kHz bandwidth allocation in the VHF band.

The 400 MHz data now includes the near-IR and water vapor spectral bands. The resolution of the data is not increased beyond that of step 2, so that the system components remain within the resources of a medium-sized user. The system performance of this system is shown in Table 4-8. The addition of two channels of data to the original 400 MHz signal has been accomplished by adoption of a quadrature modulation. This requires no increase in RF bandwidth, but does require a 3 db improvement in the RF C/N ratio at which a one in  $10^5$  error rate will be maintained. As a result, in the worst case, i. e., 5 degree antenna elevation, a 0.5 db improvement in C/N is required. This can be obtained by increasing the gain of the antenna, using a lower noise figure receiver, or increasing the output power of the spacecraft.

Transmission of all the data generated by the advanced radiometer between the 65 degree zenith angles on the S-band link is handled in a manner similar to the data processing for 400 MHz. The modulation will be quadrature. Again, the link performance margin in the worst case is negative 0.9 db. This condition is for 5 degree elevation angles and will exist for periods at the beginning and end of a pass.

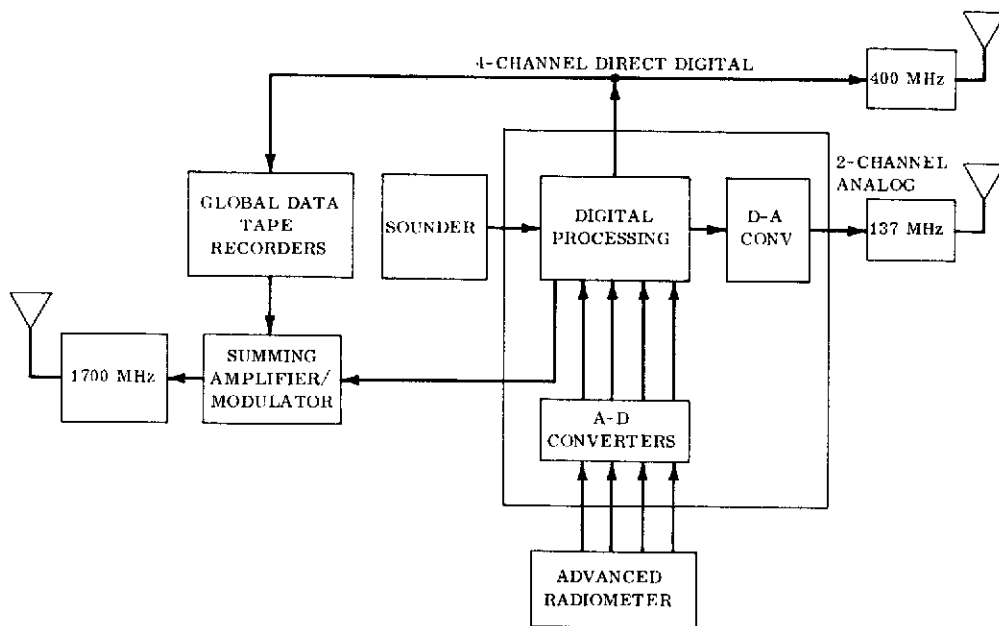

Figure 4-4 Direct Readout Systems, Step 3.

TABLE 4-8  
400 MHz and S-Band Links Step 3

Spacecraft	400				S-Band			
	<u>Nominal</u>		<u>Worst Case</u>		<u>Nominal</u>		<u>Worst Case</u>	
Transmitter	12.5 w	+11.0 dbw	10 w	10.0 dbw	6 w	+7.8 dbw	5 w	+7.0 dbw
Losses		-1.5 db		-1.5 db		-0.6 db		-0.7 db
Antenna Gain	48 <sup>o</sup>	3.0 db	55 <sup>o</sup>	2.0 db		+3.0 db		+1.9 db
Ellipticity		-1.5 db		-2.0 db		0.0 db		-0.6 db
Path Loss	1732 n.m. 20 <sup>o</sup> elev.	-155.0 db	2380 n.m. 5 <sup>o</sup> elev.	-157.7 db	1737 n.m. 2 <sup>o</sup> elev.	-167.5 db	2380 n.m. 5 <sup>o</sup> elev.	-170.3 db
Ground								
Antenna Gain		12.0 db		12.0 db	10' dish	32.0 db	10' dish	32.0 db
Circuit Loss		-1.0 db		-1.0 db		-1.0 db		-1.0 db
Received Power		-133.0 dbw		-138.2 dbw		-126.3 dbw		-131.7 dbw
System Noise & Spectral Density	1000 <sup>o</sup> K	-198.6 dbw/Hz	1000 <sup>o</sup> K	-198.6 dbw/Hz	400 <sup>o</sup> K	-202.6 dbw/Hz	400 <sup>o</sup> K	-202.6 dbw/Hz
Bit Rate	35KB/sec.	45.5 db-BPS	35KB/sec.	45.5 db-BPS	420KBPS	56.4 dBPS	420KBPS	56.3 dbBPS
Received E/No		20.1 db		14.9 db		20.0 db		14.5 db
Required E/No		15.5 db		15.5 db		15.5 db		15.5 db
Margin		4.6 db		-0.6 db		+4.5 db		-0.9 db

The weight and power impact of step 3 cannot be assessed against a known spacecraft configuration; however, the weights and powers of the components which are part of this phase may be compared to similar components of the ITOS system (Table 4-9).

TABLE 4-9

Step 4 Weight and Power

Step 3 Sensor & Data Processing	Weight (lbs)	Power (watts)	ITOS	Weight (lbs)	Power (watts)
4-Channel Radiometer (Source) TIROS N Phase A Study	70 (2)	25	VHRR (2 channel)	42(2)	8
Digital Processing	12 (2)	6			
400 MHz Transmitter (10w)	12 (2)	30			
137 MHz Transmitter (5w)	4 (2)	20	137 MHz Xmtr (5w)	4(2)	20
S-band Transmitter (5w)	8 (2)	24	S-band Xmtr (5w)		

Corollary with the alternate step 2 is an alternate configuration for step 3. The constant-resolution 2 n.m. digital data can be transmitted via the S-band link, thereby eliminating the need for a 400 MHz transmitter and not transmitting the digitized output of the 0.5 n.m. sub-point resolution instrument. Since the 0.5 n.m. sub-point resolution signal is of variable resolution, increasing to 2 n.m. x 1 n.m. at the 65° zenith, and requires a 10-foot ground antenna, the alternate appears to provide a signal which is more readily obtainable by the realtime user. The link performance, as tabulated in Table 4-7b, indicates that in the worst case the 5-watt S-band transmitter with a 5-foot ground receiving antenna yield a positive margin of 8.2 db above the 15.5 db required for a 10<sup>-5</sup> error rate with quadrature modulation.

4.1.3.4 Step 4 (Two Spacecraft with Orbit Adjust System at 907 n.m.)

A fourth step is proposed which will provide 4 channel, 1 n.m. constant resolution data for a restricted coverage area. The high resolution data for each of four narrow swaths (≈ 600 n.m. each) will be transmitted on separate S-band carriers. The 2 channel analog 2 n.m. signals on 137 MHz and the 4 channel digital 2 n.m. data on 400 MHz are as described in step 3. To provide the constant



1 n.m. data, an improvement to 0.25 n.m. sub-point resolution for the sensor is assumed. The new radiometer will operate at 480 lpm. The change in radiometer rates will require rate and storage capacity changes in the digital processor.

This fourth step provides high resolution data which can be received with a small investment in ground equipment. The spacecraft must have four separate low power transmitters (1 watt each) and an array of four S-band horn antennas, each having a 16 db gain. The radiated energy from each from each horn is concentrated in a smaller area and the data rate for each swath is reduced, thereby permitting use of a narrow bandwidth. The link analysis is shown in Table 4-10.

#### 4.1.4 Miscellaneous Processing

The recommended changes to the Direct Readout system are independent of other modifications and are simple enough in concept to be made at any time. One is the conversion of spacecraft time to a GMT reference and inclusion of time reference in the real-time data; the second is transmission of ephemeris and attitude information via the WEFAX link of the SMS.

##### 4.1.4.1 Time Marker

The ITOS spacecraft have a time code generator which counts in binary fashion in increments of 1/4 second. The code can be reset to zero by ground command and returns to zero each time time base unit selection is changed. The code word is 24 bits long.

Conversion to a binary coded decimal counter would provide a GMT referenced spacecraft time code. A minor modification to the spacecraft harness and the ground station command programmer would permit setting the spacecraft clock to 10's of seconds, with the existing 28 bit remote command word. By appropriate timing of command transmission, the clock can be set to any precision needed. Thirty bits are required to code 365 days, 24 hours, 60 minutes, and 60 seconds. Twenty-six bits are required in the command word to set to the nearest 10's of seconds. From this code it is easy to derive a two-minute or five-minute marker. A simple mark (bi-level signal) can be inserted into the analog signal and the entire code can be inserted into the digital bit stream, or can be inserted into sub-synch marks to cause a flip and return.

TABLE 4-10  
ONE OF FOUR S-BAND LINKS STEP 4

Spacecraft		
Transmitter	1 watt	0.0 dbw
Losses		-1.0 db
Antenna Gain		16.0 db
Polarization		-3.0 db
Path Loss		-170.3 db
Ground		
Antenna Gain	5'	26.0 db
Circuit Loss		-1.0 db
Received Power		-133.3 dbw
System Noise Spectral Density		-202.6 dbw/Hz
Bit Rate	64K-BPS	48.1 db-BPS
Received E/No		21.2 db
Required E/No		15.5 db
Margin		5.7 db

#### 4.1.4.2 Ephemeris Data Relay

The need for timely ephemeris data can readily be satisfied by a daily transmission of the data via the WEFAX network of SMS. A sample of APT predicts selected at random contained some 1,000 characters. This data can be transmitted in a five-minute interval along with spacecraft attitude. It can be transmitted in APT format and received on present APT display equipment. The equipment required is a receiver and teletypewriter.

## 5. RECOMMENDED SYSTEM

Based on the user requirements developed in Section 2 and the unconstrained system and trade-off analysis developed in Sections 3 and 4, in this section we set forth a recommended spacecraft system, a recommended ground system, and a discussion of the increased usefulness to users of direct readout meteorological data.

The operational meteorological satellite system will have both sunsynchronous and geosynchronous satellites.

The geosynchronous satellites in the system have the advantages of providing more frequent data readouts and a communication link for transmitting ground processed meteorological data to local users. They have the disadvantage of not providing coverage in high-latitude regions, and posing severe sensor and communication link design problems for getting high resolution and high accuracy data. The immediate potential for improvement in data quality and quantity will come from the low-altitude sunsynchronous satellites. Therefore, the study emphasizes the low-altitude satellites and their associated ground stations.

The recommended ground station primarily tailored to meet the requirements of the Class 2 user is emphasized. The small-to-medium sized station with important local region forecasting responsibilities, a class of station which can justify an increase in equipment over that of the present common minimum capability direct readout station.

### 5.1 Spacecraft System

The recommended spacecraft system for the direct readout system consists of four geostationary satellites spaced equidistantly around the equator, and two low-altitude sunsynchronous satellites, at 907 n.m. orbital altitude with orbital periods of two hours. The equator crossing local times for the low-altitude satellites are 9:00 a.m. and 3:00 p.m.

#### 5.1.1 Geostationary Satellites

The geostationary satellites have a FOFAX/WEFAX data relay link at S-band and a spin-scan camera which provides a 0.5 n.m. data in the 0.55-0.7 $\mu$ m

spectral region and 4 n.m. data in the 10.5-12.6  $\mu\text{m}$  spectral region. The geostationary satellite has the capability of providing observations every 30 minutes between a north and south latitude limit of 40 degrees (Figure 3-4). The geostationary satellite also provides a facsimile data relay by which imagery and processed meteorological data can be transmitted from large centers to the smaller stations.

#### 5.1.2 Low-Altitude Satellites

A four-channel radiometer is the primary sensor for the recommended low-altitude satellite. The four channels are visible (0.5 n.m. sub-point), near IR (0.5 n.m. sub-point), water vapor (2 n.m. sub-point) and IR (0.5 n.m. sub-point). The scan rate is 360 lines per minute. A temperature humidity vertical profile radiometer/spectrometer is the other basic sensor system.

The low-altitude satellites have four down communications links; one at 137 MHz, one at 400 MHz, and two at S-band. The 137 MHz link contains constant 2 n.m. resolution visible and IR data with geometric correction in the scan direction. The data are analog on an amplitude modulated 2.4 kHz subcarrier at a 120 line per minute scan rate. The data are not geometrically corrected in the direction along the orbital track. The resolution at the subpoint in this direction is 1.5 n.m. Two minute time marks appear in the data. Temperature humidity vertical profile data are provided. The link calculation for the 137 MHz link was shown in Table 4-6.

The 400 MHz 10-watt transmitter transmits the same quadrature phase modulated data as is transmitted on the real-time S-band link (see Table 5-1). The ground station equipment options and operational procedure options are as described for the S-band user below Table 5-1. The antenna and ancillary equipment of course are different.

The 400 MHz link is included in the recommended system in order to provide an incremental step between the VHF link and S-band link. Since the VHF link is bandwidth limited, the small VHF user who wishes to improve his capability to use more data and to use the more desirable digital data must change to the 400 MHz or the S-band link. Although it appears that the incremental cost changes in going above VHF capability may be less by using the 400 MHz link rather than the S-band, it is by no means clear cut. A more detailed study on this point based

on definitive performance and environmental specifications pertinent to the individual user needs is recommended. The link calculations for the 400 MHz link was shown in Table 4-8.

An S-band transmitter is assigned to the task of playing back the globally recorded 2 n.m. resolution, four channel radiometer data and the temperature sounder data to the Command and Data Acquisition (CDA) stations. This transmission system is not part of the direct readout system.

The second S-band transmitter is assigned exclusively to the real-time mission of transmitting the data from the meteorological sensors directly to local stations within radio range of the satellite.

The real-time S-band transmitter radiates 10 watts of power, and is quadrature modulated to provide a bit rate capability of 420K bits per second per bi-phase channel for a total bit rate capability of 840K bits per second.

Figure 5-1 is the block diagram for the recommended spacecraft system.

All the data collected for transmission has a zenith angle less than  $65^{\circ}$ . The spectral regions, resolution and data rates are listed in Table 5-1.

TABLE 5-1  
Data Content S-Band Direct Readout Link

<u>Data</u>	<u>Resolution</u>	<u>Bit Rate Kb/sec.</u>
Visible	0.5 n.m. subpoint	210
Near IR	0.5 n.m. subpoint	210
IR	0.5 n.m. subpoint	210
Water Vapor	2.0 n.m. subpoint	17
Visible	2.0 n.m. constant	17
Near IR	2.0 n.m. constant	17
IR	2.0 n.m. constant	17
Temp Profile	15 n.m. per sample	2
Spare		<u>140</u>
Total Bit Rate		840

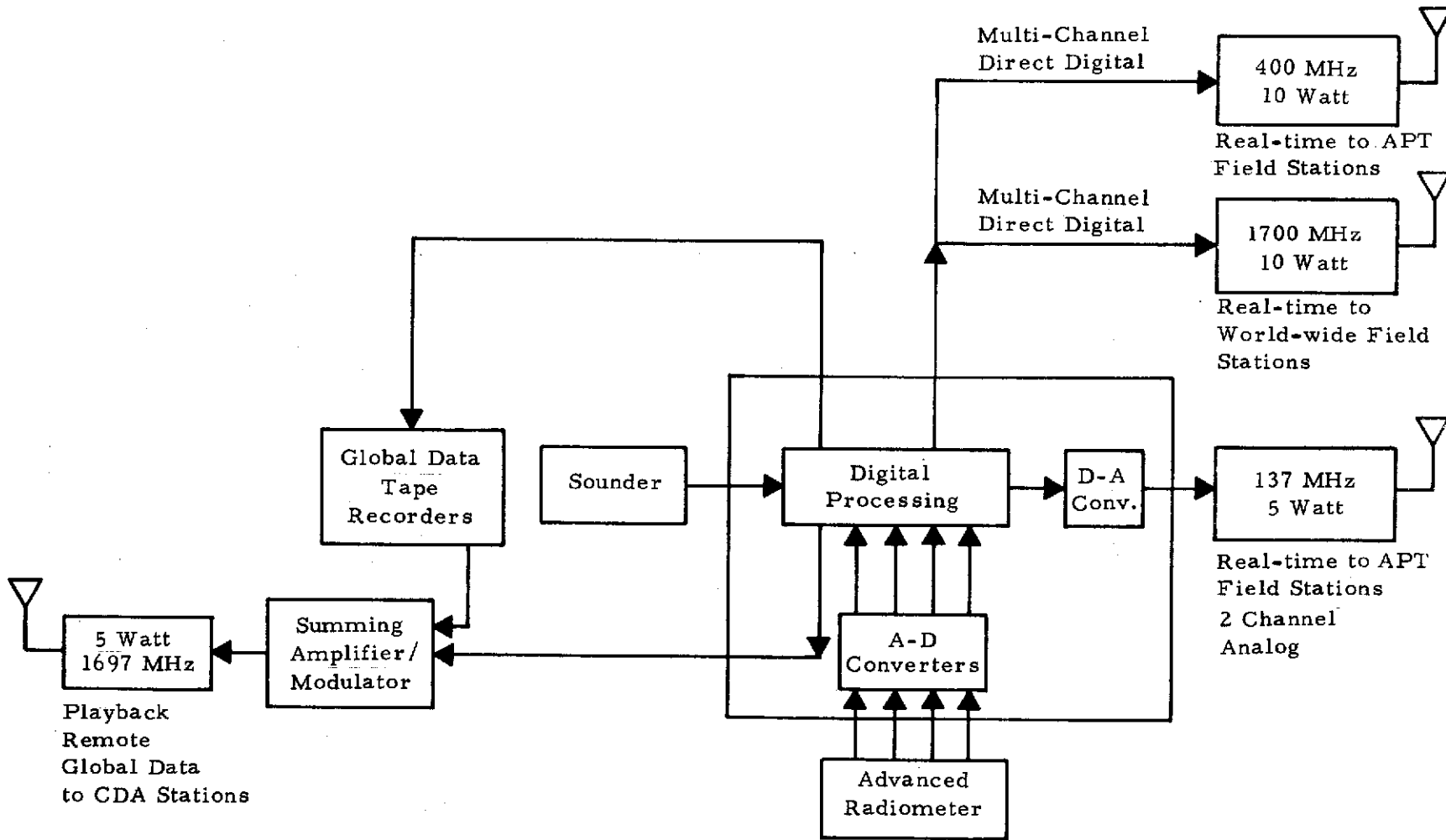

Redundancy Not Shown

Recommended Direct Readout Spacecraft System

Figure 5-1.

The user of this data requires a quadrature modulation receiver and a digital bit synchronizer and formatter. Additional equipment can be selected to fill his particular needs. If he is interested only in data in his immediate geographic area, there is no value in receiving the data from low elevation satellite passes, and he can choose a smaller antenna or less expensive pre-amplifier. He can also be selective with the data. For example, if his storage and display equipment can handle only low rate data, everything can be discarded except the constant resolution data and the temperature profile data. Another choice could be high-resolution uncorrected, IR and visible data, and three channels of constant resolution data. The choice is completely flexible, and hence, can be tailored to the user needs and budget.

The distinction between a Class 1 and Class 2 user is not made on the spacecraft. All of the data is transmitted in digital form on a single S-band transmitter. The station category is determined by the user data needs, and his selection of ground station equipment.

The direct readout S-band communication link calculations are shown in Table 5-2. Three cases are listed: a worst-case using a  $5^{\circ}$  antenna elevation; a nominal case using a  $20^{\circ}$  antenna elevation, and a worst-case for a user who is interested only in data in his local area. This latter case assumes all antenna elevations are above  $34^{\circ}$  and the ground station antenna gain used is equivalent to a five-foot dish instead of the 10-foot dish used in the other calculations. By limiting elevations to above  $34^{\circ}$ , assurance is provided that the meteorological data of the area directly above the station is viewed by the satellite at a  $56^{\circ}$  maximum zenith angle. This is also the zenith angle of the data at the point of contiguity between adjacent satellite passes over the equator. If a higher minimum elevation is used, it would be possible for a station at the equator not to be able to obtain a satellite view of the area above his station because no pass would reach that elevation.

The weight and power impact of the recommended spacecraft components cannot be assessed against a known spacecraft configuration; however, the weights and powers of the components may be compared to similar components of the ITOS system (Table 5-3).



TABLE 5-2  
S-Band Link Calculation, (900 n.m. Altitude)

	Worst-Case Limited Area		Worst-Case Full Coverage		Nominal Full Coverage	
<u>Spacecraft</u>						
Transmitter	10W	10.0 dbw	10W	10.0 dbw	12 W	10.8 dbw
Losses		-0.7 db		- .7 db		- .6 db
Antenna Gain		2.9 db		+1.9 db		+3.0 db
Elipticity		- .6 db		- .6 db		0.0 db
Path Loss	1350 n.m. 34° elev.	-163.8 db	2380 n.m. 5° elev.	-170.3 db	1737 n.m. 20° elev.	-167.5 db
<u>Ground</u>						
Antenna Gain	5 ft. dish	26.0 db	10 ft. dish	32.0 db	10 ft. dish	32.0 db
Circuit Loss		-1.0 db		-1.0 db		-1.0 db
Received Power		-127.2 dbw		-128.7 dbw		-123.3 dbw
System Noise	400°K	-202.6 dbw/Hz	400°K	-202.6 dbw/Hz	400°K	-202.2 dbw/Hz
Spectral Density						
Bit Rate (per bi-phase channel)	420K Bits	56.4 db	420K Bits	56.4 db		56.4 db
Received E/N <sub>0</sub>		19.0 db		17.6 db		23.0 db
Required E/N <sub>0</sub> (quadriphase)		15.5 db		15.5 db		15.5 db
Margin		3.5 db		2.1 db		7.5 db

TABLE 5-3

Recommended System Weight and Power

<u>Recommended System</u>	<u>Weight</u> <u>(lbs)</u>	<u>Power</u> <u>(watts)</u>	<u>ITOS</u>	<u>Weight</u> <u>(lbs)</u>	<u>Power</u> <u>(watts)</u>
4-Channel Radiometer (Source TIROS N Phase A Study)	70 (2)	25	VHRR (2 channel)	42 (2)	8
Digital Processing	12 (2)	6			
1700 MHz Transmitter (10w)	12 (2)	30			
137 MHz Transmitter (5w)	4 (2)	20	137 MHz Xmtr (5w)	4(2)	20
S-Band Transmitter (5w)	8 (2)	24	S-Band Xmtr (5w)		

## 5.2 Recommended Ground Station Configuration

## 5.2.1 Class 2 User Ground Station

Figure 5-2 is a block diagram of the recommended ground receiving system designed for the Class 2 user. Figure 5-3 shows the controls associated with the operator's (analyst's) control panel. Functions accomplished with this ground station are:

- 1) Grid computation
- 2) Antenna pointing
- 3) Low resolution display of any channel on facsimile
- 4) High resolution display of operator selected areas of the video for any channel on the CRT
- 5) Operator control of brightness/radiance transfer function about any operator selected brightness level
- 6) Gamma slicing (for radiance level identification) at any operator selected level
- 7) Superposition on visible data of points where IR channel data crosses an operator selected threshold
- 8) Grid adjustment through operator fitting of grid to lat. - long. fiducials or points of known geography.

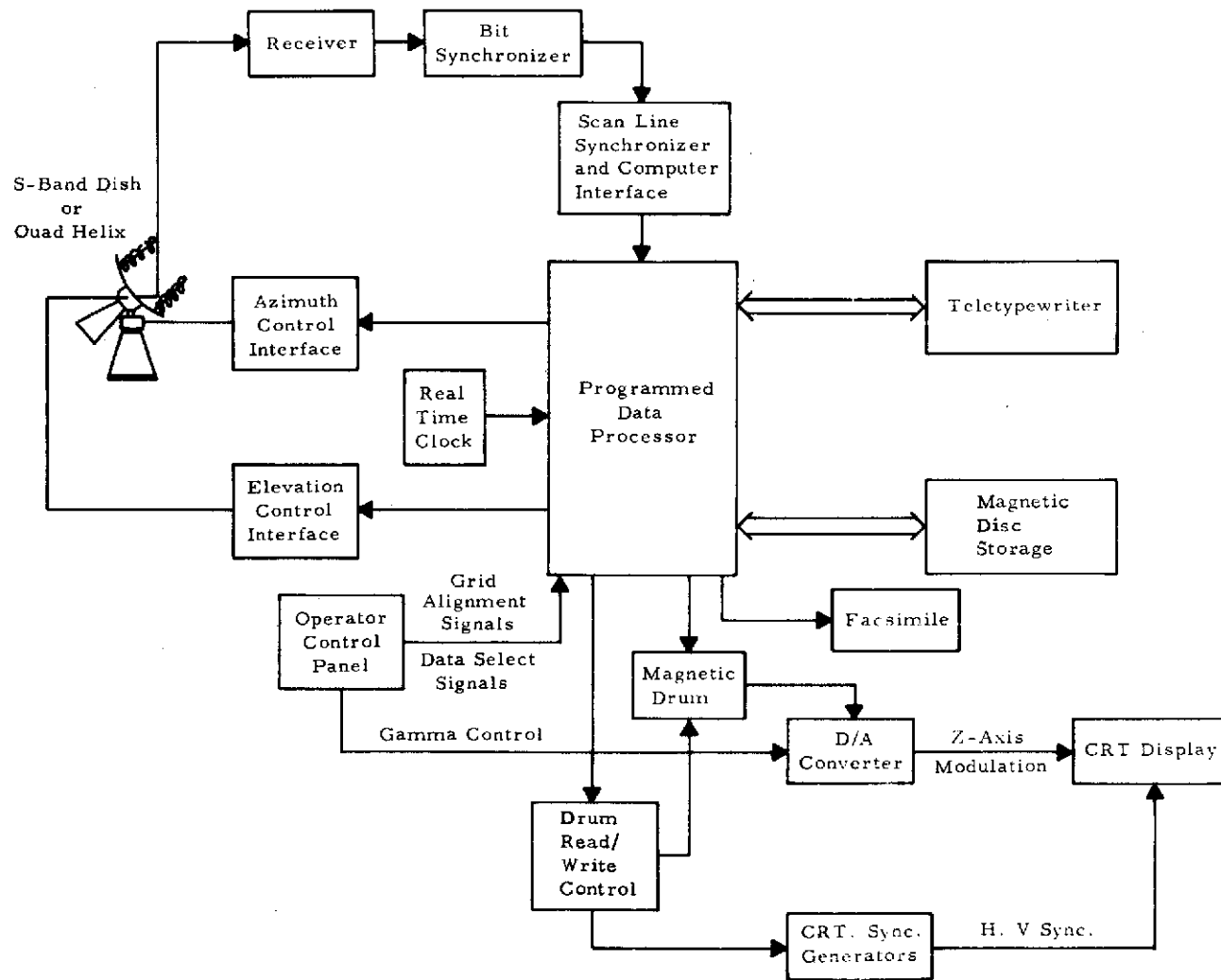
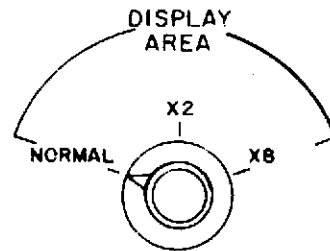
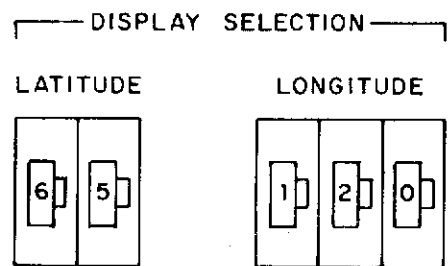

Figure 5-2 Block Diagram of APT Receiver Station.



GRID ADJUST

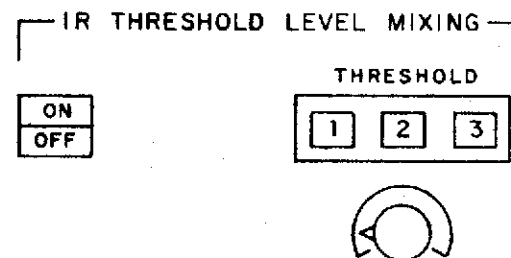
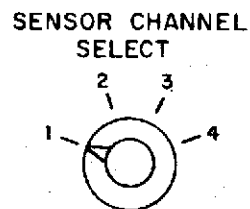
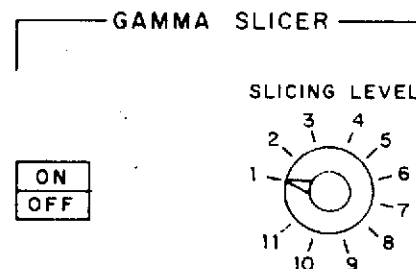
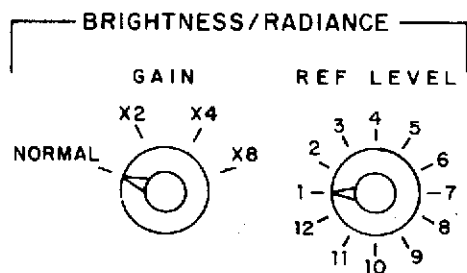
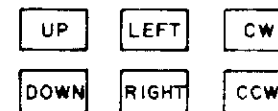

Figure 5-3 Operations Control Panel

Table 5-4 shows the timing of the various computer tasks. Computer tasks are separated to provide an even processing load.

Data received from the satellite is stored in the disc file to permit fast call-up of any portion of the data for any channel. Storage requirements for the configurations discussed above, range between 20 and 200 million bits per 10 minute acquisition (see Table 5-5). A disc store such as Digital Equipment Corporations RK05 (24.4 million bits storage) would be satisfactory. The RK05 with controller currently sells for about \$11,000. Additional discs can be added to meet the required capacity of individual stations at an additional cost of \$5,100 each.

An estimate of the recurring cost of the CRT, with magnetic drum buffer, facility for gamma slicing, brightness/radiance control, and selection circuitry for superposition of IR isobrightness lines on the visible is \$15,000.

The bit and line synchronizer would be of special design, assuming a bit error probability of  $10^{-4}$  to  $10^{-5}$ , in order to minimize the cost often associated with these items when poor signal-to-noise ratios are anticipated.

A summary of projected costs for the recommended ground station, based on today's prices and a one-system-at-a-time procurement, is as follows:

Antenna Subsystem (10-foot dish, S-band)	\$25,000
Processor with One Disc	25,700
S-Band Receiver with De- Demodulator	7,400
Facsimile Receiver	3,000
CRT/Drum Buffer	15,000
Bit/Line Synchronizer	2,000
Operator's Control Panel	2,000
	<hr/>
TOTAL	\$80,100

#### 5.2.1.1 Operator Controls

An operator selects the area to be viewed by inserting the latitude and longitude values for the center of the display on thumbwheel switches. These switches are interrogated periodically by the computer and their setting deter-

TABLE 5-4

PROCESSOR UTILIZATION

Pre-Acquisition

1. Compute azimuth and elevation antenna pointing angles as a function of time.
2. Compute grid if predicted vehicle orbit parameters have changed sufficiently to cause error limit to be exceeded for last grid computed.

Acquisition

1. Point antenna according time-based, pre-computed pointing angles.
2. Store video data is disc file.
3. Mix grid "points" into video data and output to facsimile.

Post-Acquisition

1. Transfer data from disc file to CRT buffer in accordance with data selection signals from operator's control panel.
2. Read grid data from disc file, modify coordinates in response to signals from operator's control panel, read video data from disc file, superimpose grid points, write in CRT buffer.

TABLE 5-5

## DATA STORAGE REQUIREMENTS

<u>Number of Channels</u>	<u>Bits Per Element</u>	<u>Crosstrack Resolution</u>	<u>Ground Scan Width</u>	<u>Lines Min.</u>	<u>Storage*</u>
2	8	2.0 n.m.	2340 n.m.	120	22.4 Mbit
4	8	2.0 n.m.	2340 n.m.	120	44.8 Mbit
2	8	0.5 n.m.	699 n.m.	360	68.7 Mbit

\* For ten minute acquisition period

mines which data will be transferred from the disc file to the CRT refresh memory (drum). Display area switches permit the operator to request a computer averaging of the data for a lower resolution look at a larger area.

Pushbutton switches permit the operator to request fixed increments of grid shifting either up or down, left or right, clockwise or counterclockwise. The operator would use these controls to "adjust" the grid to lat/long fiducials, time X marks or recognizable geography. In response to the operator's request, a set of pre-stored grid points would be mixed into the video data from the disc, and the composite would be written into the drum CRT refresh store.

The brightness/radiance controls, gamma slicer controls and IR transition level contour mixing are accomplished as described in sections 3.2.6.5, 3.2.6.7, and 3.2.6.8. These controls affect circuitry external to the computer and hence no processing load arises from these functions.

#### 5.2.1.2 Geostationary Satellite Data

The Class 2 station also would receive data on the PHOTOFAX/WEFAX data relay link at S-band.

### 5.3 Resulting Improvements in Meteorological Services

It is useful at this point to bring out the advantages the recommended system will bring to the users of direct readout meteorological data over the systems now used. Although the users have been classified into three general classes, it should be apparent that this classification was arbitrary and bridged the range between the small private user and the major operational meteorological center. The data provided by the recommended satellite system will satisfy the requirements of the Class 1 stations within the limits of the development of sensor technology. Thus, the requirements of any smaller station of the Class 1 type can be met by designing that station to meet its specific needs.

The recommended ground station is designed primarily to satisfy the requirements of Class 2 users, the small-to-medium size station with operational local region forecasting responsibilities. The design for this type of station was described above in Section 5.2. The data storage capability depends upon the number and capacity of data storage devices, and the selection of antenna is governed by requirements. An S-band capability and adequate storage will be assumed.



The characteristics of and requirements of Class 2 stations were given in 2.3.3.2. In short, their function is to provide operational, specific, short-to-medium-range forecasts for the "consumers," and the requirements for direct readout data are characterized by reliability, timeliness, and facility of use. Sophistication is desirable if feasible and compatible with the above.

#### 5.3.1 Reliability

Reliability includes both the assurance of receiving usable data and the accuracy of the data. The recommended system increases reliability by providing calibrated digital data. Reliability is also increased by increasing the effective power of the spacecraft antenna, and by pointing the ground antenna automatically by computer control. The degree to which received signal strength can be increased practically by strengthening the transmitted signal is severely limited, as was developed in Section 3. Thus, difficult reception conditions will have to be alleviated by a better performance ground antenna and receiver.

#### 5.3.2 Timeliness

For short-and-medium-range forecasting detailed weather forecasting, timely observations of good quality are essential. In forecasting for an operational event taking place at time (t), the forecaster needs data collected as near the time of the event as is feasible. The two principal factors involved in timeliness are the frequency of observations and processing time from time of observation until the data is available for use by the forecaster. The latter will be described under "Facility of Use" below, leaving frequency of observation to be discussed here. Frequency of observation is then directly related to the number of satellites in orbit for low-altitude satellites, and is fixed at a 30-minute interval for those stations capable of receiving data from geostationary altitude satellites.

#### 5.3.3 Facility of Use

The direct readout satellite will provide to the forecaster at the Class 2 stations, images in four spectral bands, and in addition, sounding data from the VTPR. Before the image can be optimally used, the forecaster must know the identity of the elements within the images; he must know the correct spatial relation between them, and he must know where the elements are located with re-

spect to a standard geographic frame of reference. Having this knowledge, he must compare the information contained in each of the spectral bands with any elements or system of elements contained in the images in which he is interested. The procedures were described in Section 4.2. And because timeliness is a major factor, he must do all of this rapidly and accurately. The system, as such, does not perform analysis of the meteorological data, but serves as an essential aid to the forecaster in enabling him to make rapid and accurate decisions using the mass of information available from the satellite without a large investment in time and manpower.

The ability to display large areas at low resolution, useful for analysis update, and smaller selected areas at higher resolution, important for detailed analysis and detailed short range forecasting, in a mapped or gridded form relatively soon after the observation, should be a most significant advance to the Class 2 station forecaster.

Although the Class 2 station, with its minicomputer, does not have the capability to convert the VTPR data into a vertical temperature profile, this data is transmitted in the satellite direct readout system because the user may have access to adequate computer facilities which are not an integral part of the station, because simpler techniques may be developed for conversion into temperature data, because some of the radiance data may be used directly, and because the involved data rate is low.

The Class 3 station user will also receive improved data in that he will be receiving scan-corrected 2 n.m. resolution data and a more useful time indicator.

## REFERENCES

Leonard, D. R., Automatic Picture Transmission (APT) Receiving Terminals - Status Report, Naval Electronics Laboratory Center Report 1563, 25 May 1968.

Raga, G. L., "Wideband Video Data Transmission," PGCS, Vol. Com-15, No. 1, February 1967.

White, Robert M., Letter to the Secretary-General, World Meteorological Organization for the Permanent Representative of the United States, December 28, 1971.

## BIBLIOGRAPHY

- Anderson, R.K., and Smith, A. H., "Application of Meteorological Satellite Data in Analysis and Forecasting," Supplement to ESSA Technical Report NESCS 51, U.S. Department of Commerce, November 1971.
- Baker, D. R., Flanders, A. F., and Fleming, M., "Annotated Bibliography of Reports, Studies, and Investigations Relating to Satellite Hydrology," ESSA Technical Memorandum NESCTM 10, U.S. Department of Commerce, June 1970.
- Barnes, J. D., Chang, D. T., and J. H. Willand, "Improved Techniques for Mapping Sea Ice from Satellite Infrared Data," Allied Research Associates, Final Report on Contract No. E-67-70 (H), November 1970.
- Bartlett, R. P. (ed.) 1965: Approaches to On-Board Gridding of APT Pictures, Final Report, Phase 1, Contract NAS 5-9012.
- Bartlett, R. P., G. A. Bourque, A. J. Petrella, 1965: APT, On-Board Gridding System; Breadboard Development, Phase 2, Otrly. Report No. 1, Contract NAS 5-9012, Allied Research Associates, Inc.
- Bartlett, R. P., G. A. Bourque, and A. H. Glaser, 1966: APT On-Board Gridding System, Final Report (Phase 2) Contract NAS 5-9012, Allied Research Associates, Inc.
- Bartlett, R. P. and A. J. Petrella, 1965: Application of the APT Tape Recorder to On-Board Gridding, Supplement to Phase 1, Final Report Contract NAS 5-9012, Allied Research Associates, Inc.
- Bowley, C. J., 1969: Use of Nimbus II APT to Determine the Rate of Ice Disintegration and Dispersion in Hudson Bay, Technical Report No. 8, Contract No. NAS 5-10343, Allied Research Associates, Inc.
- Chang, D. T. and W. K. Widger, 1968: Study, Simulation of Oceanographic and Geophysical Space-Sensor Displays, Technical Report: NAVTRADEVNEN 66-C-0031-1, Contract N-61339-66-C-0031, Allied Research Associates, Inc.
- Crane, H. R.: "Reception of Pictures from the Weather Satellites Using Homemade Equipment - Part I," The Physics Teacher, Vol. 7, No. 4, April 1969, pp. 209-212.

- Crane, H. R.: "Reception of Pictures from the Weather Satellites Using Homemade Equipment - Part II," The Physics Teacher, Vol. 7, No. 5, May 1969, pp. 285-287.
- Goldshlak, L, 1963: APT User's Guide, Scientific Report No. 1, Contract AF 19 (628)-2471, Allied Research Associates, Inc.
- Goldshlak, L. and W. K. Widger, 1966: The Nimbus II Data Code Experiment, Technical Note No. 1, Contract NAS 5-10114, Allied Research Associates, Inc.
- Goldshlak, L., 1968: Nimbus III Real Time Transmission Systems (DRID and DRIR), Technical Report No. 5, Contract NAS 5-10343, Allied Research Associates, Inc.
- Grey, Alan, et al, "WATSAT -- Waterloo Satellite Tracking," a joint six-student project to receive photographs from space; Department of Electrical Engineering, University of Waterloo, Waterloo, Ontario, Canada, 1970.
- Greaves, J. R. and R. P. Bartlett, 1965: Time and Error Comparisons of Manual and On-Board APT Gridding, Supplement to Phase 1, Final Report Contract 5-9012, Allied Research Associates, Inc.
- Hall, A. R., Sabatini, R. R., Sissala, J. E. and L. Novotny, 1965: Orbital and Meteorological Factors Pertinent to Satellite Transmissions of Facsimile Weather Charts, Final Report Contract NAS 5-9664, Allied Research Associates, Inc.
- Hall, A. R. and L. Berry, 1966: NASA/ESSA WEFAX Experiment - Participants' Guide, Technical Report No. 1, Contract NAS 5-10204, Allied Research Associates, Inc.
- Hall, A, R. and L. Berry, 1967: NASA/ESSA WEFAX Experiment - Evaluation Report, Technical Report No. 3, Contract NAS 5-10204, Allied Research Associates, Inc.
- Kuusela, F., and S. Poso: "Satellite Pictures in the Estimation of the Growing Stock Over Extensive Area," The Photogrammetric Journal of Finland, Vol. 4, No. 1, 1970.
- Looker, F. L.: "APT -- And All That," Part I; Electron, Vol. 7, No. 10, October 1970, pp. 33-35.

- Miller, H. J., and T. H. Vonder Haar: "Real-Time Direct Read-out Satellite Support to Meteorological Research Programs and Forecasting Units," Atmospheric Science Paper No. 181, Dept. of Atmospheric Science, Colorado State University, March 1972.
- Myers, R. F., Sprague, E. D., and B. A. Mereiro: "Controlled Processing of Direct Readout Data from Weather Satellites," U. S. Air Force, AFCRL-70-0589, 22 October, 1969.
- Portune, J. E., and C. M. Owen: "A Satellite Station for Everyone," Ambassador College APT Weather Satellite Station, Weather, Vol. 25, No. 3, March 1970.
- Sakagami, H., Yoshida, T., Arima, Y., and Y. Nakata: "An Easy Method of Receiving Picture Signals from Satellites," (English Translation), U. S. Air Force, AFCRL-71-0061, 19 February, 1971.
- Schwalb, A., "Modified Version of the Improved TIROS Operational Satellite (ITOS D-G)," NOAA TM NESS-35, U. S. Department of Commerce, April 1972.
- Smith, R. B., 1965: Manual Gridding of DRIR Facsimile Pictures, Technical Note No. 7, Contract NAS 6-3253, Allied Research Associates, Inc.
- Srinivasan, V. : "Errors in the Operational Gridding of APT Pictures," Scientific Report N. 122, India Meteorology Department, May 1970, (Pre-published).
- Staff (ARA), 1970: Nimbus IV Real Time Transmission Systems (DRID and DRIR), Technical Report No. 12, Contract NAS 5-10343, Allied Research Associates, Inc.
- Vermillion, Charles H.; "Weather Satellite Picture Receiving Stations," NASA SP-5080, National Aeronautics and Space Administration, 1969.
- Williamson, R. E.: "Satellite Picture Interpretation for Europe," 2WWTN-70-3, U. S. Air Force, September 1970.

## APPENDIX A

### Description of Present Direct Readout Systems

#### 1.0 Sources of APT Ground Stations

Table A-1 gives a representative listing of the companies that market APT stations. Of course, the components of the APT station can also be obtained separately from various companies as explained below.

#### 1.1 Antenna

The antenna system can vary widely in cost and complexity. A variety of antenna configurations are available from which to make a selection. Two basic requirements must be satisfied: a gain of at least 10 db, and a pointing capability to maintain a carrier to noise level high enough to receive clear pictures. Antennae that could be used to receive the APT signals are (1) crossed-yagi (one set of elements mounted vertically and the second set mounted horizontally through a common boom) with 8 or more sets of elements; (2) a spiral array; (3) modified discone; or (4) a log periodic type. Some manufacturers of pedestals and antennae are (1) Scientific Atlantic Corporation, 3845 Pleasantdale Road, Atlanta, Ga. 30324; (2) Andrew Corporation, Box 807, Chicago, Illinois; (3) AEL Inc., Box 552, Lansdale, Pa; (4) Telrex Engineering Laboratories, Asbury Park, New Jersey; (5) Channel Master Corporation, Eldenville, New York; (6) Antlab, Inc., 6330 Proprietors Road, Worthington, Ohio; (7) Hy-Gain Antenna Products, N. E. Highway 6, Lincoln, Neb.; (8) Cush Craft, 621 Hayward Street, Manchester, N.H.

#### 1.2 Preamplifier

Available and suitable preamplifiers include those using nuvistors, transistors, and tunnel diodes, as well as conventional tubes. For best performance, the preamplifiers should be installed at the antenna. This might indicate a choice of either the transistor or the tunnel diode models to take advantage of the use of the coaxial cable for supplying power. However, when economics and sustained good performance are taken into account, the nuvistor type is the best compromise. All of the commercially available preamplifiers offer, for the narrow bandwidth, a noise figure of about 4 db. For outdoor installation, a preamplifier with a weather-

proof box should be used. Suggested preamplifiers include: (1) Avantak, Inc., 3001 Cooper Road, Santa Clara, California; (2) Ameco Equipment Corporation, 178 Herricks Road, Mineola, New York; (3) Astro Communications Labs, 801 Gaither Road, Gaithersburg, Maryland; (4) Communications Electronics, Inc., 6006 Executive Boulevard, Rockville, Maryland; (5) Resdel Engineering Corp., 990 South Fair Oaks Avenue, Pasadena, California; (6) Telco, 10 Ardlock Place, Webster, Massachusetts; (7) Vitro Electronics, 919 Jessup Blair Drive, Silver Spring, Maryland; (8) Vanguard Electronics, Hollis, N. Y.

### 1.3 The Receiver

Like the antenna, the receiver can vary greatly in cost and complexity. The basic requirements can be met quite easily by the receiving section of most mobile receivers. Equipment is plentiful for the 150 MHz FM band, and modifications are minimal. The unit chosen should have a sensitivity of  $-96$  dgm (6 microvolts) or better, a predetection bandwidth of at least 30 KHz, and a noise figure of less than 8 db. Most facsimile printers have an input of 600 ohms, thus a receiver output at this impedance should be provided to balance it. Numerous telemetry receivers are available, but at substantially higher prices. Another possibility is the use of 144 MHz amateur band receivers. Converter modifications, if any, are simple because the frequency is close and the bandwidth is sufficiently wide for APT. Low frequency FM receivers are not common, but some used items may be found and some electronic manufacturers are now producing them. With a suitable frequency converter such as receivers will provide satisfactory operation. Some receiver manufacturers are: (1) AEL, Inc., Box 552, Lansdale, Penn., (2) Collins Radio Company, Cedar Rapids, Iowa; (3) Communications Electronics, Inc., 6006 Executive Boulevard, Rockville, Maryland; (4) Defense Electronics, Inc., Rockville, Maryland; (5) Micro State Electronics Corporation, 152 Floral Avenue, Murray Hill, New Jersey; (6) Radio Corporation of America, Front and Cooper Streets, Camden, New Jersey; (7) Vitro Electronics, 919 Jessup Blair Drive, Silver Spring, Maryland; (8) Vanguard Electronics, Hollis, N. Y.

### 1.4 The Facsimile Recorder

Facsimile recorders of the helix and writing blade type provide duplication of the transmitted video signal in varying shades of gray on a white electrolytic



recording paper. These machines can easily be modified for rephasing for every picture if desired. The picture is printed out by taking the double side band a.m. signal from the receiver, demodulating and inverting the signal, and passing it through a full wave rectifier to supply the marking current that is inversely linear to the input-signal amplitude (maximum signal with minimum marking current or minimum signal with maximum marking current). The inversion is necessary because the input signal is maximum for white, while the electrolytic paper requires a maximum signal for black. The facsimile equipment for the present APT system must operate at 48 rpm to be compatible with the satellite equipment which uses a 2,400 Hz carrier frequency and operates on an a.m. double sideband signal. Photofacsimile recorders with automatic processors are also available. Some recorders employ a cathode ray tube and a Polaroid camera. In general, the photographic processes produce the best results. The Polaroid camera types produce copies that may be too small for some uses.

Several manufacturers of facsimile equipment have machines compatible with the transmitted signal. Among these are: (1) Alden Electronics and Impulse Recording Equipment Company, Inc., Westboro, Massachusetts; (2) Electro-Mechanical Research, Inc., 5012 College Avenue, College Park, Maryland; (3) Muirhead Instruments, Inc., 1101 Bristol Road, Mountainside, New Jersey; (4) Scientific Atlantic Corporation, 3845 Pleasantdale Road, Atlanta, Georgia; (5) Westrex Division, Litton Industries, Le Fevre Lane, New Rochelle, New York; and (6) T. H. Giff Company, 1141 Fountain Way, Anaheim, California.

#### 1.5 Tape Recorder

A tape recorder should be considered as part of the system to record picture data received from the satellite for playback to the picture recording device (facsimile, cathode ray tube, etc.). This storage feature permits post orbital pass analysis and multiple reproduction of the pictures received from the satellite. The second channel of the tape recorder may be used to record the synchronizing signal generated in the facsimile recorder. On playback, this signal may be used to control the facsimile recorder drum speed. A high quality stereophonic audio tape recorder with good speed regulation and low flutter and wow characteristics should be employed. There are many suppliers of such equipment.

TABLE A-1

MANUFACTURERS OF APT GROUND STATIONS

Alden Research Center  
Westboro, Mass. 01581  
U. S. A.

Bell Telephone Manufacturing Company  
Mr. J. H. Gustin, Chief Engineer  
Missile and Space Systems  
Bell Telephone Mfg. Company  
Jan Van Rijswijcklaan 162  
Antwerpen, Belgium

Compagnie Industrielle Radioelectrique  
Bundesgasse 16  
Berne (Suisse)

Electro-Mechanical Research, Inc.  
5012 College Avenue  
College Park, Maryland 20740  
U. S. A.

Hell Telephoeo Recorders  
Dr. Ing. Rudolf Hell  
2300 Kiel  
Grenzstrasse 1-5  
Federal Republic of Germany

Muirhead & Company, Ltd.  
1101 Bristol Road  
Mountainside, New Jersey 07092  
U. S. A.

Muirhead Italiana S. R. L.  
40 Via Marco Besso  
Rome, Italy

Muirhead & Company, Ltd.  
Beckenham, Kent, England

Rhode & Swartz  
Muhldorfstrasse 15  
Munchen 8  
Federal Republic of Germany

Scientific-Atlanta, Inc.  
Post Office Box 13654  
Atlanta, Georgia 30324  
U. S. A.

Vaisala  
Helsinki 44  
Finland

## 2.0 S-Band Direct Readout Ground System

The High Resolution Picture Transmission (HRPT) service, introduced by the launch of NOAA-2 in October 1972, broadcasts on an S-band frequency and therefore requires an entirely different ground station from the VHF APT type because of the high resolution and associated bandwidth. This ground station is much more sophisticated and expensive than that required to receive APT data. At present, only two such ground stations are operative, and are located at NASA-Goddard Space Flight Center. One station is manned by NASA, the other by NOAA. NOAA plans to operate about 5 such stations in the U. S. in the near future.

Following is a short description of the Direct Readout Ground Station (DRGS) developed for NASA by Image Information, Inc. The DRGS provides ground terminal facilities for receiving, recording, and displaying the visible and infrared imagery collected by the VHRR on NOAA-2 and the VISSR of the Synchronous Meteorological Satellite planned for launch in late 1973. The three major subsystems of the DRGS are:

- 1) Antenna-Pedestal Assembly
- 2) Receiving and Demodulating Electronics
- 3) Recorder-Processor-Display Subsystem

The Antenna-Pedestal assembly is composed of a solid surface parabolic reflector (18' high in diameter for VISSR and VHRR reception, 10' in diameter for VHRR reception), a parametric amplifier and down converter mounted in the feed assembly, and a pedestal with required servo drives.

The Receiving and Demodulating Electronics provide facilities for data receiving, tracking error determination, and demodulation of the signals transmitted from the satellite.

The image Recorder-Processor-Display subsystem is composed of a laser drum recorder with an associated rapid-access dry processor.

## 3.0 Present Direct Readout Station Procedures

Operation of present VHF APT ground station systems equipped to receive data for meteorological purposes generally follow four main procedures:

1) Prediction of Satellite Passage and Antenna Pointing Angles:

Satellite ephemeris information from teletype service is generally used for graphical calculations on a tracking board. Some APT stations use computer-calculated satellite passage times and antenna pointing angles.

2) Recording of APT Picture:

Recording equipment may vary from paper facsimile to a photograph of an oscilloscope tube. Time may be manually annotated on the picture or a digital clock may be photographed at the picture start signal.

3) Geographic Referencing:

Geographic grids from a film grid library (such as the NOAA Grid Library) may be projected and traced on the individual pictures or correct size strip grids may be used on a light table to trace grids on the picture. Some users also employ an area grid with landmarks and coastlines ready-made to the size and best-fit scale of the APT pictures.

4) Extraction of Meteorological Information from the Gridded and/or Montaged Pictures:

Technicians may prepare nephanalyses for facsimile transmission or may use various other procedures to extract useful information from the data.

APPENDIX B

QUESTIONNAIRE  
TO DETERMINE NEW APPLICATIONS FOR  
DIRECT READOUT DATA FROM SATELLITES

Please fill out form below as comprehensively as possible.

1. Organization Name and Address

---

---

---

2. Responsible Individual(s) Title, Address, Phone No.

---

---

---

3. Type of Activity

- (a) Operational
- (b) Applied Research and Development

4. Check Category (or Categories) of your Activity

- (a) Public Safety: Federal, Municipal, Other
- (b) Industrial: Manufacturing, Wholesale, Retail
- (c) Utility: Gas, Electric, Water
- (d) Construction: Land, Offshore, Marine
- (f) Transportation: Land, Marine, Air
- (g) Communication: Private, Public, News Media, Commercial,  
(radio, TV, Cinema)
- (h) Agriculture
- (i) Recreation
- (j) National Defense
- (k) Other (specify)

---

---

---

5. Define missions and/or operations that have meteorological data requirements.

---

---

---

---

---

---

---

---

---

---

6. Indicate your familiarity with meteorological satellite Direct Readout (DR) data:

Very Slightly Not  
\_\_\_\_ Familiar \_\_\_\_ Familiar \_\_\_\_ Familiar \_\_\_\_ Familiar

7. Have you or anyone on your staff ever worked with good quality photographic reproductions of either APT or DRIR data (see enclosed examples).

\_\_\_\_ Yes \_\_\_\_ No

8. Do you presently receive DR satellite data at your facility (either with your own antenna or by land-line from an antenna located elsewhere).

\_\_\_\_ Yes \_\_\_\_ No

9. (a) Whether you do or do not receive DR data at your facility, do you use other satellite data transmitted on National facsimile network?

\_\_\_\_ Yes \_\_\_\_ No

and/or

(b) on forecasters facsimile (FOFAX)?

\_\_\_\_ Yes \_\_\_\_ No

(c) Do you find these facsimile-transmitted satellite data useful? Yes \_\_\_\_  
No \_\_\_\_ . If so, how do you apply these data to your mission?

---

---

---

---

10. Please check in the table below the scales of weather features (e.g., cyclones, fronts, squall lines, organized convective cloud masses, etc.) and meteorological parameters (e.g., temperature, moisture, etc.) required by your activity and indicate whether present data sources satisfy your requirements for land and ocean areas. In addition, please specify whether you believe that DR data would be a useful source of information where no other source is now available to you or in addition to present sources.

	Weather Features		Meteorological Parameter Data	
	Land	Ocean	Land	Ocean
Synoptic Scale (Required, R; Not Required, NR)				
Satisfied by present sources (Yes, No)				
Would DR data be useful? (Yes, No)				
Meso Scale (R, NR)				
Satisfied by present sources? (Yes, No)				
Would DR data be useful? (Yes, No)				
Micro Scale (R, NR)				
Satisfied by present sources? (Yes, No)				
Would DR data be useful (Yes, No)				

11. Based on your experience with satellite data in general, what do you feel are the most significant limitations to the use of these data for your particular mission?

---

---

---

---

---

---

---

---

---

---

---

---

---

---

---

---

---

---

---

---

---

---

---

---

12. Which aspect(s) of interpretation of satellite weather information would require (additional) training?

- Recognizing various weather features
- Determining stage of development of weather features
- Determining characteristics of weather features
- Determining cloud types
- Inferring upper air information
- Interpreting infrared data
- Interpreting water vapor channel data
- All of the above
- None of the above



13. (a) If you are a current user of DR data, please indicate your mode of operation, receiving and display equipment, other capabilities of your system and types and frequency of problems you encounter with the system.

---

---

---

---

---

---

---

---

---

---

13. (b) Please suggest improvements you would like to see with future satellite DR systems.

---

---

---

---

---

---

---

---

---

---

APPENDIX C

REVIEW OF PLANNED SENSORS AND SPACECRAFT  
DIRECT READOUT SYSTEMS

The following schedule represents the planned growth in the National Operational Meteorological Satellite System (NOMSS). The current polar orbiting component of the system, TIROS M, will be replaced by a modified version, ITOS D & E, about the same time the first Synchronous Meteorological Satellite (SMS) is launched. While the preliminary design of the next generation of polar orbiting spacecraft, TIROS N, has been initiated, no specific designs have been formulated for future versions of synchronous spacecraft. Also shown are the two remaining NIMBUS launches.

<u>SPACECRAFT</u>		<u>PLANNED LAUNCH DATE</u>						
		1971	1972	1973	1974	1975	1976	1977
Operational	ITOS "B"		▲					
	ITOS "D" (NOAA -2)			▲				
	SMS				▲			
	TIROS N							▲
Experimental	NIMBUS E (NIMBUS-5)		▲					
	NIMBUS F					▲		

1.0 ITOS "D"

The ITOS "D" series of spacecraft employs the basic TIROS M spacecraft system with a new sensor complement. The first spacecraft in this series is scheduled for launch in mid-1972. There are three primary sensor subsystems and two direct readout links. The Very High Resolution Radiometer (VHRR), the Scanning Radiometer (SR), and the Vertical Temperature Profile Radiometer (VTPR) compromise the sensor complement with data from the SR being sent real time via VHF and data from the VHRR being sent real time via S-band. The VTPR data requires considerable ground processing and will not be discussed further.

## 1.1 VHRR

The VHRR is a two channel scanning radiometer operating at 400 rpm; this is consistent with a ground resolution of 0.5 n.m. at a 790 n.m. altitude. The basic parameters are shown in the following table.

<u>Channel</u>	<u>Resolution</u>	<u>Sensitivity</u>	<u>Bandwidth</u>	<u>Duty Cycle</u>
0.6 - 0.7 $\mu\text{m}$	0.5 n.m.	S/N >1 for 65 fl	35 KHz	1/2
10.5 - 12.5 $\mu\text{m}$	0.5 n.m.	1.0 $^{\circ}$ K at 300 $^{\circ}$ K 3.0 $^{\circ}$ K at 185 $^{\circ}$ K	35 KHz	1/2

## 1.2 SR

The SR is a two-channel scanning radiometer operating at 48 rpm. The basic parameters are shown in the following table.

<u>Channel</u>	<u>Resolution</u>	<u>Sensitivity</u>	<u>Bandwidth</u>	<u>Duty Cycle</u>
0.5 - 0.7 $\mu\text{m}$	2.8 mr	S/N > $\frac{20}{1}$ for 0.5% albedo	900 Hz	1/2
10.5 - 12.5 $\mu\text{m}$	5.3 mr	1.5 $^{\circ}$ at 300K 6.0 $^{\circ}$ at 185 $^{\circ}$ K	450 Hz	1/2

Note that the IFOV for the two channels are different. The scan speed is consistent with the IR channel giving a subpoint resolution of 4.2 n.m. The visible channel is thus underscanned so that the along scan resolution is 2.2 n.m. and the across scan resolution is 4.2 n.m.

## 2.0 SMS

The first SMS, now being designed and built by Philco-Ford is scheduled for launch in 1974. After an initial testing phase by NASA, the satellite will be operated by NOAA and designated the Geostationary Operational Environmental Satellite (GOES).

SMS is a multi-function satellite (observation and data relay) whose primary sensor is a single Visual and Infrared Spin Scan Camera (VISSR). The communications functions are accomplished with transponder and high power S-band Transmitter.

## 2.1 VISSR

The VISSR has eight high resolution visible detectors and two (redundant) medium resolution infrared sensors which scan the earth by the spinning motion of the spacecraft. The specific parameters of the VISSR are shown in the following table.

<u>Channels</u>	<u>Spectral Region</u>	<u>Resolution</u>	<u>Sensitivity</u>	<u>Duty Cycle Per Channel</u>	<u>Bandwidth</u>
8	0.55 - 0.70 $\mu\text{m}$	0.5 n.m.	SNR = 9db 0.5% albedo	5%	2.5mb/s
1 (redundant)	10.5 - 12.60 $\mu\text{m}$	4.0 n.m.	2.5 $^{\circ}$ at 180 $^{\circ}$ K 0.3 $^{\circ}$ at 330 $^{\circ}$ K	5%	

The VISSR data from the spacecraft will be transmitted to the CDA station in 30 ms bursts every 600 ms spin period (spin rate 100 r/min). There it will be stretched and retransmitted to the spacecraft for transmission to regional real time stations (Data Utilization Stations((DUS)) ).

## 2.2 Communications

There will be two types of field stations served by the SMS system; regional Data Utilization Stations (DUS) and modified APT stations. Both stations will be served by the same S-band 1690 GHz 20 watt transmitter. The DUS will have a 15' antenna and an uncooled parametric preamp. This station will be capable of receiving the stretched, retransmitted VISSR data. The present APT stations will require the addition of an S-band antenna (6 ft.) and an S-band to VHF converter. These stations will receive the relay of PHOTOFAX satellite cloud cover pictures and weather charts (WEFAX). Since each function requires the full power of the transmitter in the satellite, the VISSR data, the stretched VISSR data, and the FAX transmissions

must time-share the transmitter.

### 3.0 TIROS N

The sensor complement for TIROS N has been conceptually configured. Table C-1 shows the two primary instruments with their basic design parameters.

#### 3.1 Advanced Very High Resolution Radiometer

The AVHRR scans at 360 rpm (consistent with a resolution of 0.5 n.m. at a 907 n.m. altitude) perpendicular to the subsatellite track. The 6.7  $\mu\text{m}$  channel, being an absorption band, requires a detector 25 times larger than the other three channels to achieve the specified sensitivity. Thus, this channel is over-scanned and only one out of every 6 scans is used.

In addition to video data at the resolutions indicated in the table, a digital processor will be used to derive a lower resolution output in the three high resolution channels. The resolution has tentatively been set at 2 n.m. (along scan dimension) by 3 n.m. (across scan dimension). The specific resolution, however, is easily modified by a change in the digital processing scheme. Buffering or duty cycle improvement, can also be considered to be available. Thus presently, the system is planned to have seven outputs:

<u>Channel</u>	<u>Spectral Region</u>	<u>Resolution (n.m.)</u>	<u>Duty Cycle</u>	<u>Bandwidth</u>
1	0.50 - 0.7 $\mu\text{m}$	0.5 x 0.5	100%	267 bps.
2	0.50 - 0.7 $\mu\text{m}$	2.0 x 3.0	100%	16 bps.
3	0.75 - 1.0 $\mu\text{m}$	0.5 x 0.5	100%	267 bps.
4	0.75 - 1.0 $\mu\text{m}$	2.0 x 3.0	100%	16 bps.
5	10.5 - 12.5 $\mu\text{m}$	0.5 x 0.5	100%	267 bps.
6	10.5 - 12.5 $\mu\text{m}$	2.0 x 3.0	100%	16 bps.
7	6.5 - 7.0 $\mu\text{m}$	2.0 x 3.0	100%	16 bps.

TABLE C-1

TIROS N SENSOR PAYLOAD

<u>SENSOR</u>	<u>CHANNELS</u>	<u>SPECTRAL REGION</u>	<u>RESOLUTION*</u>	<u>SENSITIVITY</u>	<u>DUTY CYCLE</u>	<u>BAND-WIDTH</u>
Advanced Very High Resolution Radiometer (AVHRR)	Visible (1)	0.5 - 0.7 $\mu\text{m}$	0.5 n.m.	S/N > 1 for 0.5% albedo	1/3	40 KHz
	Near IR (1)	.75 - 1.0 $\mu\text{m}$	0.5 n.m.	S/N > 1 for 0.5% albedo	1/3	40 KHz
	Far IR (1)	10.5 - 12.5 $\mu\text{m}$	0.5 n.m.	0.3° at 300° K	1/3	40 KHz
	Water Vapor (1)	6.5 - 7.0 $\mu\text{m}$	2.4 n.m.	1.0°K at 200°K	1/18	10 KHz
Operational Vertical Sounder (TOVS)	Tropospheric (5) Temperature	15 $\mu\text{m}$ CO <sub>2</sub>	15.8 n.m.			
	Ozone (1)	9.7 $\mu\text{m}$ O <sub>3</sub>	15.8 n.m.			
	Water Vapor (3)	22 $\mu\text{m}$ H <sub>2</sub> O	15.8 n.m.			
	Tropospheric (5) Temperature	4 $\mu\text{m}$ CO <sub>2</sub>	15.8 n.m.			
	Tropospheric (2) Temperature	53 $\mu\text{m}$ GHz O <sub>2</sub>	15.8 n.m.			
	Window (2)	11 $\mu\text{m}$ ; 3.8 $\mu\text{m}$	15.8 n.m.			
	Stratospheric (3) Temperature	15 $\mu\text{m}$ CO <sub>2</sub>	15.8 n.m.			

\* at satellite nadir

#### 4.0 NIMBUS E

Several instruments planned for flight on Nimbus E and F could be applicable to a direct readout mission. Others which fall in the category of sounding instruments or spectrometers will not have outputs which would be useable without considerable processing. Only those instruments falling in the former category will be discussed.

##### 4.1 Temperature - Humidity Infrared Radiometer (THIR)

The THIR is a two-channel scanning radiometer observing emitted radiation in the 10.5 - 12.5  $\mu\text{m}$  window and the 6.7  $\mu\text{m}$  water vapor channel. Both of these channels will exist in the TIROS N AVHRR, so no further discussion of this instrument will be made here.

##### 4.2 Electrically Scanning Microwave Radiometer (ESMR)

The ESMR is designed to measure emitted radiance in the 19.35 GHz region. The objective being to map globally and contiguously the thermal radiation emitted by the earth's surface and by the atmosphere over a brightness temperature range of 50<sup>o</sup> to 330<sup>o</sup>K. However, the physical temperature can only be extracted if some knowledge of the emissivity is available. Qualitatively, though, areas of heavy precipitation and heavy rain clouds will be contrasted strongly against the earth background and can be identified, tracked, and distinguished from other less important cloud formations. Surface features will also be apparent in many cases.

The ESMR uses a two-dimensional electrically scanned planar array capable of receiving one polarization. The antenna beam will have a circular angular resolution of 1.4<sup>o</sup> (16 n.m. at 600 n.m.) and will be step scanned  $\pm 50^{\circ}$  perpendicular to the flight path of the spacecraft. The analog voltages representing each radiance measurement are digitized to 10 bit accuracy. A full scan is 80 words or an output data rate of 200 bits/sec. As presently planned, this data will be recorded for remote playback only.

##### 4.3 Surface Composition Mapping Radiometer (SCMR)

The SCMR is a three-channel scanning radiometer with a 1  $\mu\text{m}$  bandpass at .6  $\mu\text{m}$ , 10.7  $\mu\text{m}$ , and 9.1  $\mu\text{m}$ . The IFOV is 0.6 mrad and the scan speed is

560 rpm. This instrument is very similar to the VHRR on ITOS D except that there are two channels in the far IR window. Since the effect of water vapor absorption is different in the two regions, the two measurements allow the atmospheric absorption effects to be removed resulting in higher accuracy in sea surface temperature measurements. This does, however, require some ground processing.

#### 5.0 NIMBUS G

The sources of the ESMR experiment on Nimbus 5 have led to an improved microwave instrument being considered as a potential experiment on Nimbus G which will provide direct readout to modified APT stations. This experiment, Scanning Multi-Channel Microwave Radiometer (SMMR) will provide microwave image data for the study of sea ice and ice age, snow cover depth, sea surface winds, soil moisture, cloud liquid water content ( drop size), etc.