

2

NASA TECHNICAL MEMORANDUM

NASA TM X-52644

NASA TM X-52644

(NASA-TM-X-52644) COMMENTS ON THE
FEASIBILITY OF DEVELOPING GAS CORE
NUCLEAR REACTORS (NASA) ~~40~~ p HC \$4.00
41

N74-11518

CSSL 18I

Unclass
21981

G3/22

COMMENTS ON THE FEASIBILITY OF DEVELOPING GAS CORE NUCLEAR REACTORS

by Frank E. Rom
Lewis Research Center
Cleveland, Ohio

TECHNICAL PAPER proposed for presentation at
Frontiers of Power Technology Conference
sponsored by Oklahoma State University
Stillwater, Oklahoma, October 23-24, 1969

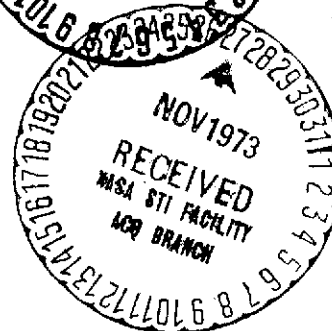
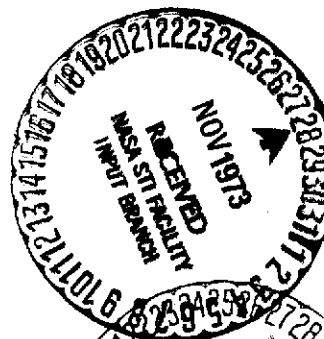

COMMENTS ON THE FEASIBILITY OF DEVELOPING GAS
CORE NUCLEAR REACTORS

by Frank E. Rom

Lewis Research Center
Cleveland, Ohio

TECHNICAL PAPER proposed for presentation at

Frontiers of Power Technology Conference
sponsored by Oklahoma State University
Stillwater, Oklahoma, October 23-24, 1969

NATIONAL AERONAUTICS AND SPACE ADMINISTRATION

ABSTRACT

Recent developments in the fields of gas core hydrodynamics, heat transfer, and neutronics indicate that gas core nuclear rockets may be feasible from the point of view of basic principles. Based on performance predictions using these results, mission analyses indicate that gas core nuclear rockets may have the potential for reducing the initial weight in orbit of manned interplanetary vehicles by a factor of 5 when compared to the best chemical rocket systems. In addition, there is a potential for reducing total trip times from 450 to 500 days for chemical systems to 250 to 300 days for gas core systems. The possibility of demonstrating the feasibility of gas core nuclear rocket engines by means of a logical series of experiments of increasing difficulty that ends with ground tests of full scale gas core reactors is considered. It appears to be feasible to devise such a series of experiments and the facilities to go along with them. The facility requirements consist chiefly of additions to or modifications of existing facilities.

COMMENTS ON THE FEASIBILITY OF DEVELOPING GAS
CORE NUCLEAR REACTORS

by Frank E. Rom

Lewis Research Center

SUMMARY

Recent developments in the fields of gas core hydrodynamics, heat transfer, and neutronics, ^{indicate} that gas core nuclear rockets may be feasible from the point of view of basic principles. Specific impulse is expected to be in the range of 1500 to 2500 seconds for thrust levels of the order of 100,000 to 1,000,000 pounds of thrust and powerplant weights in the range of 100,000 to 300,000 pounds. The ratio of hydrogen to uranium mass flow rates may be of the order of 100 to 1. Based on performance predictions using these results, mission analyses indicate that gas cores have the potential for reducing the initial weight in orbit of manned interplanetary vehicles by a factor of 5 when compared to the best chemical rocket systems. In addition, there is a potential for reducing total trip times from 450 to 500 days for chemical systems to 250 to 300 days for gas core systems. Calculations show that there is no pollution or radiation hazard produced by the release of all the fission products and unfissioned uranium from gas cores into space.

Because of these results, it is timely to consider whether a logical, feasible, and economically reasonable development program that could produce a flyable man-rated gas core nuclear rocket engine is conceivable. A major goal in such a program is a series of experiments of increasing difficulty that ends up with the ground test of full scale gas core reactors. Such a series of experiments can be envisioned. Each experiment significantly increases the confidence that gas core engines are feasible. The first steps are small, yet significant enough so that if they are successful, they will give the confidence necessary to undertake the next step. The facilities required are additions or modifications

to existing facilities. The costs are, therefore, expected to be reasonable. A full-scale gas core engine test facility, for example, may require only the addition of a scrubber and a stack to an existing nuclear rocket test facility at the Nuclear Rocket Development Station at Jackass Flats, Nevada.

It is concluded that it is possible to formulate a logical series of experiments that would permit the proving of the feasibility of a gas core nuclear rocket by means of final full scale gas core reactor ground tests. This conclusion assumes, of course, that good performance continues to materialize at each step in the program.

INTRODUCTION

Recent developments in the fields of gas core hydrodynamics, heat transfer, and neutronics indicate that gas core nuclear rockets may be feasible from the point of view of basic principles. Based on performance predictions using these results, mission analyses indicate that gas cores will reduce the initial weight in orbit of manned interplanetary vehicles by a factor of 5 when compared to chemical systems. In addition, there is a potential for reducing total trip times from 450 to 500 days for chemical systems to 250 to 300 days for gas core systems. No particular space hazards or pollution problems are anticipated by allowing the fission products and unburned uranium to escape to space. These favorable results indicate the need to more seriously consider the gas core nuclear rocket as a possible space propulsion system.

The question of whether the feasibility of gas cores can be firmly established with a logical series of experiments ending with full scale ground tests is a pertinent one. This report reviews recent important gas core developments and outlines steps required to establish feasibility of a gas core space propulsion reactor.

RECENT DEVELOPMENTS AND BACKGROUND

Lewis Research Center through in-house and contracted efforts has been conducting basic work in the fields of hydrodynamics (refs. 1 to 26), gaseous radiant heat transfer (refs. 27 to 56), and neutronics (refs. 57 to 69), as well as system studies (refs. 70 to 77) since 1953 when the first plausible concept of a gas core nuclear rocket was proposed. There was very little knowledge in each of these three basic fields that could be applied to determining the feasibility of any gas core concept. During the course of establishing the basic technology, several concepts were conceived and dropped. The coaxial-flow concept originally conceived about 1960 (ref. 6) finally evolved into a porous-wall spherical gas core reactor concept (refs. 25 and 26) that is referred to herein as the Lewis gas core concept. Based on recent data, this is a concept that may be feasible. It appears as if it might be possible to maintain a sufficiently large volume of uranium vapor within a cavity reactor to assure criticality while hydrogen flows through the cavity with a flow rate that is 100 times that of the uranium. Calculations indicate that the heat from the fissioning uranium can be transferred to seeded hydrogen by thermal radiation while limiting the heat flux to the cavity walls so that wall cooling is not a problem. The rate of seed material addition required to enable the hydrogen to absorb the thermal radiation and to protect the walls is of the order of 0.1 to 1.0 percent of the hydrogen flow rate. This amount of seed has a negligible effect on specific impulse.

Lewis Gas Core Concept

A schematic drawing showing the principal features of this concept is shown in figure 1. The proposed reactor is basically spherical and is composed of an outer pressure vessel, an outer cold-circulating deuterium oxide (D_2O) zone, a beryllium oxide (BeO) zone that is regeneratively cooled by the hydrogen propellant, an inner second-pass D_2O circulating zone, and finally a porous or slotted cavity liner. The D_2O moderator is

pumped first through the outer region, then through the inner region. The D_2O is collected in a toroidal header from which it is passed through a heat exchanger where it is regeneratively cooled by the incoming cold hydrogen.

The hydrogen is pumped to a pressure of 500 to 1000 atmospheres by means of a turbopump operated by hydrogen bled from an intermediate station in the propellant circuit. After the D_2O is cooled in the regenerative heat exchanger, the hydrogen is ducted to a plenum at the downstream end of the reactor. Most of the hydrogen then flows through passages within the BeO region for cooling purposes. (Whatever gamma and neutron heating is not picked up in the inner region of D_2O is picked up by the BeO.) The hydrogen then is ducted into the spherical plenum behind a porous or slotted wall. Appropriate seed particles which are about the size of smoke particles are introduced into the hydrogen as it enters this plenum region. The seeded hydrogen then flows through the porous or slotted wall. By properly designing the shape of the porous wall and by proper injection and distribution of the hydrogen flow through this wall, a relatively stagnant nonrecirculating central region forms within the cavity. The cavity is about 10 feet in diameter. The central fuel region occupies about one-half of the cavity volume.

Uranium metal is injected into this region. It vaporizes and rises to temperatures sufficient to thermally radiate the energy that is generated by the fissioning uranium. A proposed fuel injection technique consists of pushing a rod of solid uranium metal through a cadmium shielded pipe that penetrates the moderator. As it enters the cavity the uranium instantly vaporizes and rises in temperature to about $100,000^{\circ} R$. Reactor startup could be achieved by first establishing the hydrogen flow. Next uranium particles would be blown into the dead cavity region to achieve nuclear criticality. The power would then be increased to a level sufficient to vaporize the incoming uranium rod.

The seeded hydrogen is heated solely by absorbing the thermal radiation from the fissioning uranium fireball. The cavity walls receive only a small fraction of a percent of the thermal radiation from the fireball. This is accomplished by introducing about 1/10 of 1 per-

cent by weight of a seeding material like graphite particles into the hydrogen. This same technique is used in the nozzle region to reduce the hydrogen radiation heat load and the hydrogen temperature near the nozzle wall to tolerable levels. Seed concentrations of about 1 percent are required here. Figure 1 shows that some cold hydrogen can be introduced through the nozzle walls directly from the plenum at the downstream end of the engine if it is required.

The weight of the powerplant to produce 200,000 pounds of thrust is estimated to be of the order of 200,000 pounds (ref. 24). Increasing the thrust level to 1 million pounds would increase the weight to about 300,000 pounds. The specific impulse can range from 1500 to 2500 seconds depending on the operating outlet gas temperature. At 1500 seconds the average outlet gas temperature is about $10,000^{\circ}$ R, and at 2500 seconds the average outlet gas temperature is about $15,000^{\circ}$ R. The reactor power level for 200,000 pounds of thrust is about 10,000 megawatts at a specific impulse of 2000 seconds. Based on recent experimental data the ratio of hydrogen to uranium flow is expected to be about 100 to 1 (refs. 25 and 26).

Recent Experimental Results

Experimental data have been obtained on isothermal gas core reactor flow mockups, hot-flow mockups which use radiofrequency (RF) induction directly coupled with flowing gases to simulate nuclear heating, and on full-scale nuclear mockups to obtain neutronic critical experiment data. This section briefly describes the most recent experimental results and the possible implications of these results.

Cold-flow experiments. - A two-dimensional mockup was made of the Lewis gas core concept to determine whether a large dead region could be maintained in the center of the cavity while maintaining a high ratio of outer to inner flow (refs. 25 and 26). Figure 2 shows the test section. The expansion of the uranium is simulated in this isothermal test by means of a showerhead arrangement through which smoky air

simulating the uranium is flowed. The outer walls are made of strips of brass sheet punched with 1/64-inch holes spaced on 1/32-inch centers. The test section is about 10 inches across the cavity and about 6 inches deep. The nozzle wall contour was adjusted to provide a desirable non-recirculating flow pattern within the cavity. Figure 3 shows the test section operating with a flow ratio of 100 to 1. The range of the instrumentation did not permit measurements at higher flow ratios. The smoke concentration does not change rapidly with time even when the inner flow is stopped completely. It is suspected that higher flow ratios may be possible through geometry changes of the test section. Figure 4 shows the measured smoke concentration profiles from a run with a flow ratio of 100. The volume occupied by the stagnant zone is about 40 percent of the cavity volume, and the density of the smoke is, on the average, about 50 percent of the density at injection. In a real reactor this would require an operating pressure of about 500 to 1000 atmospheres to provide sufficient uranium for nuclear criticality.

United Aircraft Research Laboratories under contract to the joint AEC/NASA Space Nuclear Propulsion Office has been carrying out experiments on a pure coaxial-flow system shown in figure 5 (ref. 12). Figures 6(a) and (b) show the flow pattern with mass flow ratios of 30 and 55, respectively. The lower value is about as high as has been attainable while maintaining a central stagnant zone. It is clear that at the higher value of 55 the stagnant zone vanishes due to strong recirculating flow patterns. When a thick high-porosity material was placed across the inlet face, it was not possible to produce recirculation cells that caused the disappearance of the central dead region, even for much higher flow ratios than previously observed. This is shown by the photographs of the flow in figures 6(c), (d), and (e) for flow ratios of 30, 80, and 130, respectively. Experiments were run at flow ratios of up to 300 with similar results. It was beyond the measuring capability of the experimental apparatus to obtain quantitative data for higher mass flow ratios.

The results of these isothermal experiments at Lewis and at United Aircraft Corporation indicate that flow ratios of about one hundred may be possible for gas core cavity reactors.

Hot-flow tests. - Lewis has conducted nonisothermal tests using up to 1 megawatt of RF power at the TAFA Division of the Humphreys Corporation (refs. 54 to 56). About 600 kilowatts of heat is generated directly within the flowing gas to simulate nuclear fission heating. An RF field produced by a coil surrounding the test section couples with the ionized flowing gas. Figure 7 shows a 1 megawatt RF test set-up. In these tests it has been observed that heating of the inner flowing gas eliminates recirculation. Recently, for the first time, measurements were made of the concentration profiles of the gases directly in the RF discharge within the inner flowing gas. Figure 8 shows the profiles with and without heating to illustrate the calming effect of the heat addition. Notice, for example, the difference in the shape of the 0.5 concentration profile when heat is added to the flow. This experiment leads to the belief that mixing may be greatly reduced by heat addition to the central gas. This is, of course, of great significance in a real gas core engine where the ratio of hydrogen to uranium flow would be further increased because of the reduced mixing resulting from the steep temperature gradients accompanying the enormous heat addition in the central region.

Critical experiments. - In the field of gas core neutronics, extensive critical experiments have been carried out on a full-scale gas core cavity reactor mockup (refs. 62 to 69) shown in figure 9. This experimental gas core cavity is 6 feet in diameter and 4 feet long. It is surrounded by a 3-foot-thick reflector-moderator region of heavy water on all sides. The outer diameter of the reactor is 12 feet and it is 10 feet long. Generally, uranium foils 1 mil thick are distributed in the cavity region to simulate the gaseous uranium. (Experiments were also run in which uranium hexafluoride gas was used to give a more accurate representation of gaseous uranium.) The fuel was distributed within the cavity in many ways to simulate the shape, size, and concentration distribution of fuel as it might occur in real reactor operation. The effects of hydrogen propellant between the fuel zone and the cavity wall, and also mixed with fuel, have been investigated. The effect of lumpy fuel distributions such as might

occur when the coflowing hydrogen and uranium gases pass through the cavity has been investigated.

The experiments have yielded a good understanding of gaseous cavity reactors that was impossible to obtain by analysis. The body of data now available constitutes a challenge to the analyst to provide theoretical solutions that can be used within the limitations of today's computers. In essence the critical experiment is used as an analog computer. In $2\frac{1}{2}$ years of operation, over 600 configurations have been investigated. All of our estimates of critical mass and reactivity effects of real gas core reactors are now based on these experimental data. These estimates are the most reliable ones available.

Missions

A few mission performance calculations were made in order to determine whether a gas core with the characteristics described previously would have the potential for a significant improvement over chemical or solid core nuclear rocket performance. The mission for this calculation consisted of a 420-day manned Mars landing mission in 1980 as described in reference 77. Gas core performance was compared to solid core performance. The following engine characteristics were used. They are typical of the first generation solid core nuclear rocket and ^{potential} ~~anticipated~~ performance for a gas core engine. The solid core rocket may eventually achieve a specific impulse of 925 seconds and its weight may be lower than indicated in the table. It is not expected that the general conclusions drawn from an analysis made using these assumptions will be significantly affected should the solid core potential materialize.

Characteristic	Solid core nuclear rocket	Gas core nuclear rocket
Specific impulse, sec	825	2500
Thrust, lb	75,000	100,000 to 1,000,000
<i>Engine</i> Weight, lb	25,000	100,000 to 800,000 ^{300,000}

The solid core nuclear rocket initial vehicle weight in orbit is 2.2 million pounds. For an engine weight of 200,000 pounds, the gas core nuclear rocket initial vehicle weight in orbit^{1/3} is 800,000 pounds, or about 1/3 the weight of the solid core system. Inasmuch as solid core nuclear rockets for manned Mars missions require an initial weight in orbit about 1/3 to 1/2 that for chemical rockets (ref. 77), the gas core requires only ^{1/3}1/4 to 1/6 the initial weight of a chemical system. Some of the reduction in initial weight can be traded for a reduction in trip time by the gas core rocket. Even for trip times as low as 250 to 300 days, the initial weight in orbit of the gas core will be about 1/2 that of advanced chemical systems for 450 to 500 days trip time.

In all the cases above, aerodynamic braking was used for the Earth return maneuver. If the gas core were used for this maneuver, the gas core engine, the crew quarters, the life-support equipment, and the final tankage would be recovered for possible reuse. In this case the initial vehicle weight in orbit for the gas core would be about 1.3 million pounds or about 1/2 the weight of the solid core nuclear rocket which uses aerodynamic braking. The solid core nuclear rocket system uses a total of six or seven engines in this mission; the gas core uses only one, which can be recovered. These potential advantages of the gas core, simplicity and recoverability, deserve further examination.

Potential Radiation Hazards from Gas Core Plume

The exhausting of all fission products and unburned fissionable material into space by the gas core rocket may give concern because of a potential space pollution or radiation hazard problem. Calculations have been made that show that the exhaust plume containing all the fission products expands so rapidly that in 0.01 second after the gas leaves the nozzle the dose from fission products to a person directly in the plume would be less than the normal background dose from cosmic and solar sources. In 1 hour after shutdown, the concentration of all exhaust particles including hydrogen, uranium, and fission fragments would be down to the normal particle concentration in interplanetary space.

There are two other sources of radiation hazards from the exhaust plume that might affect the personnel aboard the gas core powered vehicle. One is the direct radiation to the crew compartment from the "radioactive exhaust jet" plume. The other is radiation to the crew compartment from fission fragments that may diffuse forward from the plume and deposit on the outside surface of the vehicle. Preliminary estimates indicate that these problems are negligible, but studies are being made to verify this conclusion.

The potential effect of trapping ionized radioactive or high-energy particles in the Van Allen belt must be mentioned. The fission products produced by a gas core in a typical 20 minute earth departure operation are about equivalent to those produced by a 3-kiloton weapon burst. Inasmuch as the time that a gas core would exhaust fission products while in the high intensity portions of the Van Allen belt would be only a small fraction of its operating time, Van Allen trapping is considered to be an insignificant problem.

DEMONSTRATION OF GAS CORE FEASIBILITY

The work in the fields of neutronics, hydrodynamics, and gaseous radiant heat transfer has shown that the Lewis gas core concept may be

basically feasible. The anticipated performance of this engine yields a substantial improvement in manned interplanetary space mission capability. The feasibility studies that have been carried out thus far have neglected the mutual interactions between neutronics, hydrodynamics, and heat transfer because of the difficulty in carrying out work in each of the areas. There can be no question that mutual interactions between neutronics, hydrodynamics, and heat transfer are first-order effects in a gas core reactor. Even though the work in each of these separate fields is generating very important new knowledge in its own right, and is now sufficiently advanced to predict possible gas core feasibility, it is not likely that further work which neglects interactions will greatly aid in determining whether or not a gas core may be practical as a propulsion device. The next major advances toward determining the practicality of gas cores will therefore come as a result of attempting to determine the interactions between the three basic areas of investigation. No meaningful gas core reactor dynamics or control studies can be done until these interactions become known. Neither will it be possible to predict achievable ratios of hydrogen to uranium mass flow until the mutual effects are understood.

The steps required to show feasibility of a gas core are outlined in figure 10. Each step begins with relatively simple extensions of present work that provides the confidence required to advance to the next step if the results continue to be promising. The steps include work that is already completed or underway and continues into the future, to when a full-scale engine designed for flight is first tested. The diagram shows the start in 1953 when the first Lewis gas core concept was conceived. Because of the lack of basic data in existence at that time, the program was split into three separate basic fields - neutronics, hydrodynamics, and heat transfer. Currently, the cold static critical experiments, isothermal hydrodynamic analyses and experiments, and heat-transfer analyses and experiments in each of these fields indicate that no major change is likely to occur that would alter the conclusion that a gas core may be feasible from the point of view of basic principles.

The next step requires experiments that combine fields. The figure shows the possibility of combining neutronics and hydrodynamics in

a cold-flowing-gas critical experiment. Also shown is a parallel step that combines hydrodynamics and heat transfer in RF-heated-flowing-gas experiments. Both experiments are relatively minor extensions of the work now accomplished or underway in each of the fields that they combine. They use basic technology that has been demonstrated by previous work. Each of these steps is discussed in more detail in the following sections of the report.

The cold-flowing-gas critical experiment and hot-flowing-gas experiments should lead to small-scale fission-heated tests to be operated in a high-flux test reactor. A test reactor that would be required to carry out these experiments is described in a later section. The small-scale fission-heated tests lead to full-scale gas core tests that in turn, define a flight propulsion gas core engine for ground testing.

Cold-Flow Critical Experiments

The purpose of cold-flow critical experiments is to determine the interaction between the hydrodynamics and neutronics of a gas core reactor. It should provide information on the controllability, dynamics, and stability of gas cores. The effect of temperature and heat transfer cannot be included in this reactor test because the reactor would have to be operated at high power levels. This, of course, would greatly affect the complexity and cost and would make such an experiment a very large premature step. The cold-flow critical experiment is a necessary low-risk forerunner to a power test.

The cold-flow critical experiments can be considered to be a logical extension of the cold static critical experiment program that is now in progress at the AEC National Reactor Testing Station. A schematic diagram of one concept for this proposed experiment (ref. 78) is shown in figure 11. The reactor is similar to that used in the cold static experiments now underway, in that the reactor is basically a large tank of D_2O moderator. The cavity in this experiment is designed according to the principles that have been learned from the most promising cold-flow hydrodynamic experiments. The fuel is uranium hexafluoride (UF_6)

and the propellant some gas such as dry nitrogen or oxygen.

The UF_6 is fed into the system (as it was in the cold static gas core critical experiments) by heating liquid UF_6 to a temperature of about 230°F and a pressure of 35 psia. The cavity diameter is about 40 inches. The UF_6 is fed into the dead region of the cavity by an injection system which would be defined by cold-flow hydrodynamic experiments. The propellant gas is fed from a circulating pump to a plenum region behind the appropriately designed porous or slotted wall in the cavity. The design of the wall would also be determined by the cold-flow hydrodynamic experiments.

The resulting mixture of UF_6 and propellant gas in this design is ducted to NaF absorber beds that remove the UF_6 from the exhaust gas mixture. The propellant simulating gas is pumped back to the reactor. A run of about 10 to 20 minutes would be required to gather the necessary data. After each run the mixture of propellant gas and UF_6 is passed through a cold trap to condense out the UF_6 . The UF_6 is then recovered by heating the trap and recondensing the UF_6 in the UF_6 supply system. The system would then be ready for another run. Other techniques for removal and recovery of the UF_6 from the flowing gases leaving the experiment are being considered. One such scheme uses a cold-trap system of a previously proven design that has been used in handling UF_6 . Another uses an organic compound that is capable of absorbing UF_6 gas from a mixture leaving the reactor. The total amount of UF_6 involved in any of these operations is about 60 kilograms. Several runs per week can be made with these systems.

The operating technique proposed for this experiment is designed so that all operations are conducted in a safe controllable fashion. The first phase of the experiment would be to carry out a complete set of hydrodynamic and system experiments with UF_6 containing natural uranium. The core region is well instrumented in this phase so that the size, shape, and density of the fuel region will be known over the entire operating range of all variables. The second-phase experiment uses fully enriched UF_6 , but a dividing

wall separates the entire fuel region from the flowing propellant region. The shape and size of the volume contained by this wall is determined from the cold-flow tests. These experiments with the dividing wall will be used to determine neutronic characteristics independent of flow. The third, fourth and each succeeding phase will be tests with more and more of dividing wall removed. The amount that can safely be removed in each step is determined from the data for each preceding experiment. Finally, the dividing wall will be completely removed, and the operation of a cold gas core flowing reactor will be demonstrated.

A feasibility study of carrying out a cold flow critical experiment (ref. 78) indicates that such an experiment is a reasonable undertaking in that it could be safely and economically carried out. It would be an important step forward toward an operating gas core reactor. It would demonstrate that a reactor with gaseous fuel restrained by hydrodynamic means only, could be fully controlled during startup and steady-state, low-power, isothermal operation.

Hot-Flow Experiments

The purpose of the hot-flow RF experiments is to determine the effect of heat addition and large temperature gradients on the mixing between the coaxially flowing gases. Radiofrequency power can be used to inductively heat the central flowing gas that simulates hot fissioning uranium gas. The RF experiments that have been conducted at the TAFA Division of the Humphreys Corporation (refs. 54 to 56) have proven the feasibility of heating gases inductively at power levels up to 1 megawatt. Data have been obtained from idealized coaxial-flow experiments where the central gas was argon and the surrounding propellant gas was hydrogen or air.

Figure 12 shows one of the several torch designs tested at a power level of 500 kilowatts. The cylindrical chamber below the torch is the flow header assembly that allows simultaneous but independent variation of several gas flow regions. The header also provides for cooling

water distribution. The RF coils are about 6 inches in diameter for this particular test. The plasma does not contact the walls of the torch.

The next logical step is to carry out experiments with flow geometries that are representative of the kind that in isothermal tests produce mass ratios of outer to inner flow greater than 100. It is also desirable to provide in these experiments an injection system (see fig. 13) that would simulate a real engine injection system. In a real engine, a typical injection system would utilize a solid rod of uranium that is fed into the hot fissioning uranium gas. This might be simulated in an RF experiment by feeding a rod of graphite into the plasma. The rod could be loaded with metallic or other atoms as necessary to obtain the desired optical properties of the plasma.

In the experiment, the walls that surround the plasma and its surrounding gas would be fabricated of porous tubes that provide flow patterns as obtained in the isothermal work. Concentration measurements would be made directly within the plasma by a technique that was developed and successfully used in work that is now underway at TAFA (refs. 54 to 56). The injection end of the experiment is designed to permit rapid changes of injector configurations. This is an area which has not been investigated in isothermal tests. Experience gained in consumable electrode arc furnaces is directly related to this work and can be used as a guide. Upon successful completion of these tests, a 1-megawatt small-scale (4-in. -diam) simulated gas core nuclear reactor engine would have been demonstrated.

A question can be raised as to whether RF heating is a good way to simulate nuclear heating, because the electrical and magnetic forces produced by the interaction of the plasma with the RF field might be of concern. Calculations have shown that RF heating in the frequency range of about 1 megacycle with the gases at 1-atmosphere pressure should closely simulate nuclear heating. During the course of one cycle, the electrons in the plasma move, at the very maximum, a distance of only 2 millimeters. When compared to the dimensions of the plasma (30 to 100 mm), the oscillations of the electrons produced by the electrical and magnetic forces is negligible. Of course, the movement of the ions

would be orders of magnitude less than the electrons and would be completely insignificant. In addition the potential magnetic pressures built up by the magnetic fields are small compared to pressures that exist in the system. It appears as if RF inductive heating is a good way to simulate nuclear heating in a gas.

It may be feasible to conduct RF experiments at power levels higher than 1 megawatt. Higher power levels would be required to simulate gas core operation at gas blackbody radiation temperatures required for high-thrust full-scale gas core reactors ($20,000^{\circ}$ R). A 4-inch model with a 2-inch-diameter plasma zone would require an RF power supply of about 15 megawatts for an effective blackbody radiating temperature of at least $20,000^{\circ}$ R. A 20-inch model with a 10-inch-diameter fuel zone would require an RF power supply of about this same size for operation at an effective radiating temperature of at least $10,000^{\circ}$ R. For a radiating temperature of over $20,000^{\circ}$ R, the required power for the 20-inch test would be considerably more than 15 megawatts. Commercially available RF power supplies are now operating at power levels in the range of 1 to 2 megawatts. The construction of units in the range of 15 megawatts appears feasible because they would be scaled-up versions of the up 1- to 2-megawatt units. The major cost item for such an experiment would be the power supply. If further tests on RF heating show that high power can be induced in gas with induction units operating in the kilocycle rather than the megacycle frequency range, the cost of carrying out the high power tests could be greatly reduced. It is, therefore, important to do exploratory experiments designed to determine how low a frequency can be used successfully. (Frequencies as low as 60 Hz have been used to inductively heat large steel pieces. The plasmas that have been generated thus far in our RF work have behaved electrically as steel. Steel is used, for example, in place of plasma to tune up the RF power supplies.) The use of low-frequency power for induction heating would permit much larger scale, higher temperature tests than proposed above for the same cost.

In-Pile Test of Gas Core Models

It is not possible to carry out a small-scale, gas core, in-pile test in conventional MTR-type test reactors such as the Plum Brook Reactor, MTR, ETR, GETR, or ORR. Uranium would be used in these tests as the fuel material to produce fission heating. The operating temperature of the uranium fuel region must be above the boiling point so that the uranium remains gaseous. At a pressure of 1000 psi, the boiling point of uranium is about $11,000^{\circ}$ R. If the edge temperature of the fuel plasma is set at $11,000^{\circ}$ R, the radiant heat loss (hence, the operating power) can be computed. The result of this calculation is shown by the dashed line in figure 14. A 2-inch-diameter sphere of uranium vapor with an edge temperature of $11,000^{\circ}$ R will radiate $\frac{7.2}{7}$ megawatts of power. The number of uranium atoms per unit volume can be computed for any desired pressure level. The flux level required to generate the desired $\frac{7.2}{7}$ megawatts can then be determined because the fuel atom density and cross sections are known. For example, the required thermal neutron flux for a 2-inch uranium gas sphere operating with an edge temperature of $11,000^{\circ}$ R at a pressure of 1200 psi is 5×10^{16} nv (where n is the number of neutrons per unit volume and v is their mean velocity). The highest flux available in conventional test reactor space of sufficient volume is substantially less than 10^{15} nv; therefore, a meaningful gas core experiment cannot be done in conventional test reactors.

It appears to be feasible to design a test reactor system that would produce a flux level of 10^{16} neutrons per square centimeter per second. In order to achieve the highest flux per unit of reactor power, the non-productive absorption of neutrons in the reactor system must be carefully minimized. This permits low concentrations of uranium to be used in the power-producing part of the reactor system. The lower the volumetric concentration of uranium, the higher will be the flux required for a given power. In addition, a flux trap can be used to amplify the flux level in the test zone. A preliminary conceptual sketch of such a test reactor is shown in figure 15. An annular reactor core about 40 inches

high and about 62 inches in outer diameter, with an inner diameter of about 30 inches is shown. The reactor is fabricated of aluminum fuel plates similar to those of the conventional MTR reactors such as the Plum Brook Reactor. The fuel loading, however, is reduced by a factor of 15 less than PBR fuel. For the same power density, therefore, the flux level in this core would be about 15 times that for PBR. This low fuel loading is made possible because D_2O is used as the reactor coolant and because about 3 feet of D_2O is used as a reflector outside the core. The use of the 30-inch D_2O island in the center of the core will increase the flux level to greater than 10^{16} neutrons per square centimeter per second by trapping. Reactor calculations indicate that for a power of 920 megawatts the average flux level in the trap will be 10^{16} neutrons per square centimeter per second.

Reactor cooling in this concept is by natural convection of high-pressure (100 psi) D_2O . The use of natural convection eliminates the need for pumping large quantities of D_2O . It also permits the D_2O to be completely contained in a tank about 12 feet in diameter and 10 feet high. This tank has a vertical through-hole 30 inches in diameter into which experiments can be inserted. The D_2O is cooled as it circulates through a light-water steam generator. For a 1000-megawatt reactor, about 1000 pounds per second of steam will be generated. A gravity-fed 1-million-gallon water supply will permit the reactor to operate for more than 2 hours. If continuous operation is desired, a light-water pumping system and cooling tower must be provided. A facility such as this might be located at either the NRDS, Nevada, or NRTS, Idaho.

The gas core model to be tested is installed in a 30-inch D_2O -filled test module that is inserted into the reactor test hole. The propellant and fuel delivery systems, and any cooling system required, are considered to be a part of the test module. In figure 15 is shown a 20-inch gas core model with a 10-inch-diameter fuel zone. The power level of the gas core test is 34 megawatts. Its operating pressure is 1200 psi, and its effective blackbody radiation temperature is over $11,000^{\circ}$ R.

The exhaust from the gas core test is cooled in a water spray scrubber. The cooled gases and water vapor from the scrubber are exhausted to the atmosphere through a suitable stack. The noble gas fission products that escape to the atmosphere are of insignificant consequence to off-site locations. The uranium that is diluted with large quantities of water can be processed in existing fuel reprocessing plants for reclamation.

By further optimization it may be possible, with this basic concept, to achieve flux levels higher than 10^{16} neutrons per square centimeter per second.

Full-Scale Gas Core Test

A full-scale gas core reactor operating with a specific impulse of about 2000 seconds and a thrust level of 200,000 pounds has a power level of 10,000 megawatts and a chamber pressure of 500 atmospheres. The hydrogen flow rate is 100 pounds per second. The uranium flow rate is of the order of 0.1 to 1 pound per second. The average enthalpy of the exhaust gas is 83,000 Btu per pound. This corresponds to an average exhaust temperature of $11,500^{\circ}$ R. For a 20-minute run, a total of 120,000 pounds of hydrogen and from 120 to 1200 pounds of uranium would be required. There would be about 140 grams of uranium fissioned, and therefore there would be of the order of 140 grams of fission products generated. The total amount of heat released would be about 1.2×10^{10} Btu. This corresponds to the latent heat of 1.2×10^7 pounds (1.5×10^6 gal) of water. The rate of steam production, if the entire 10,000 megawatts were used to boil water, would be 10,000 pounds per second.

A facility for testing a gas core reactor with the above operating conditions could be designed as an addition to the nuclear rocket test facilities at the Nuclear Rocket Development Station in Nevada. Figure 16 shows schematically the equipment that would be required in addition to a test stand such as ETS-1. Liquid hydrogen at a flow rate of about 100 pounds per second is required. The high-pressure

pump required to produce the reactor operating pressure of 500 to 1000 atmospheres is considered to be a part of the gas core power-plant to be tested. The exhaust from the engine is ducted into a water spray scrubbing chamber. This scrubber is about 50 feet in diameter and 100 to 150 feet long. The scrubber condenses out all the uranium vapor and condensable fission products. The gaseous effluent from the scrubber would be a mixture of hydrogen and steam. The noble fission gases (about 20 grams of Xe and Kr) are entrained in this effluent, which is discharged through a stack to the atmosphere. The hydrogen flow leaving the stack is about 1/3 of the hydrogen flow of the Phoebus test reactor. The effluent can be burned as it leaves the stack, as in the case of the Phoebus tests. The advantage of burning is that the hot plume gives better dilution and dispersion of the fission products.

The noble gas fission products from this reactor test would give a radiation dose 5 miles downwind about one-thousandth that permissible to the general population. The calculation conservatively assumes adverse weather conditions and that the release occurred at ground level directly upwind of the measuring point.

If required, the steam-hydrogen mixture could be passed through a particulate filter, a baffling system, or a separation system to assure that no droplets of water are entrained in the effluent. The droplets would allow condensable fission products to be released to the atmosphere if they were not removed from the exhaust plume.

The water storage required for a 20-minute test run would be about 3-million gallons. Half of this water is vaporized in the scrubber, the remaining water is used to flush away and dilute the uranium and condensable fission products. The mass ratio of water to uranium that would produce criticality is 100 to 1. In the facility the ratio of water to uranium for the worst case would be 10,000 to 1. There is, therefore, a factor of safety of at least 100 as far as a potential criticality accident is concerned.

The water containing the uranium and fission products would be cooled in a storage basin. This mixture would then be sent to a fuel

reprocessing plant to recover the unburned fuel.

The operation of the gas core powerplant test and the additional equipment required is therefore considered to be technically feasible. The cost would probably be in the same ballpark as that for solid core nuclear rocket engine testing.

CONCLUDING REMARKS

Recent experiments in the fields of gas core hydrodynamics, heat transfer, and neutronics indicate that gas core nuclear rockets may be feasible from the point of view of basic principles.

Mission analyses show that gas core nuclear rockets ^{should} ~~will~~ reduce the initial weight in orbit of manned interplanetary vehicles by a factor of 5 when compared to advanced chemical systems and by a factor of 2 when compared to solid core nuclear rockets. In addition, there is a potential for reducing trip times from 450 to 500 days for chemical and solid core nuclear rocket systems to 250 to 300 days for gas core systems.

Calculations have shown that there is an insignificant pollution or radiation hazard produced by the release of all the fission products and unfissioned uranium from gas cores into space.

In order to justify continuing work on gas core reactors, it is necessary to determine whether it is possible to devise a series of experiments that will give assurance that gas core reactors are feasible. The feasibility must be determined with sufficient certainty to warrant the eventual construction and test of full-scale gas core reactors. It is also necessary to determine whether a reasonable technique can be conceived to permit development of flight-rated gas core engines on the ground. If there is no hope that a gas core can be developed by means of a ground tests, there would be little incentive to continue gas core feasibility studies.

The following conclusions can be made as a result of this study:

1. A logical series of experiments can be conceived to establish feasibility gas core reactors in an orderly stepwise fashion. The final step in such a series is the ground test of a full scale gas core reactor.

2. It appears to be technically feasible to carry out ground tests of full scale gas core reactors as well as the necessary intermediate experiments prior to full scale ground tests.

3. A cold-flowing gas core mockup critical experiment that uses uranium hexafluoride as the fuel and a gas such as nitrogen to simulate the hydrogen appears to be feasible. This experiment would provide data on gas core dynamics and the interaction between neutronics and fluid flow. It neglects the effect of power production and temperature.

4. A nonnuclear hot-flow experiment that simulates the combined hydrodynamic and heat-transfer characteristics within gas cores appears to be feasible. Radiofrequency induction heating is used as the heat source to simulate fission heating. This experiment would provide data on the effect of the interaction of heat generation high temperature gradients and fluid flow in gas core reactors.

5. It does not appear feasible to design a meaningful fission-heated flowing gas experiment for neutron flux levels available in existing test reactors.

6. It appears to be feasible to construct a test reactor that would provide the flux level of about 10^{16} neutrons per square centimeter per second for meaningful gas core mockups of the order of 20 inches in diameter.

7. It is concluded that a full-scale experimental gas core reactor and flight design gas cores could be tested in facilities similar to existing nuclear rocket test facilities. Modifications would be required to provide a scrubber for cleaning up the exhaust gases before discharging them to the atmosphere.

REFERENCES

1. Ragsdale, Robert G. : NASA Research on the Hydrodynamics of the Gaseous Vortex Reactor. NASA TN D-288, 1960.
2. Ragsdale, R. G. ; and Weinstein, Herbert: On the Hydrodynamics of a Coaxial Flow Gaseous Reactor. Proceedings of Nuclear Propulsion Conference, Naval Postgraduate School, Monterey, Calif., Aug. 15-17, 1962. AEC Rep. TID-7653, pt. 1, July 1963, pp. 82-88.
3. Savino, Joseph M. ; and Ragsdale, Robert G. : Some Temperature and Pressure Measurements in Confined Vortex Fields. J. Heat Transfer, vol. 83, no. 1, Feb. 1961, pp. 33-38.
4. Ragsdale, Robert G. : Applicability of Mixing Length Theory to a Turbulent Vortex System. NASA TN D-1051, 1961.
5. Ragsdale, Robert G. : A Mixing Length Correlation of Turbulent Vortex Data. Paper 61-WA-244, ASME, Nov. 1961.
6. Weinstein, Herbert; and Ragsdale, Robert G. : A Coaxial Flow Reactor - A Gaseous Nuclear-Rocket Concept. Paper 1518-60, ARS, Dec. 1960.
7. Ragsdale, Robert G. ; Weinstein, Herbert; and Lanzo, Chester D. : Correlation of a Turbulent Air-Bromine Coaxial-Flow Experiment. NASA TN D-2121, 1964.
8. Ragsdale, Robert G. : Effects of Momentum Buffer Region on Coaxial Flow of Dissimilar Fluids. Paper 65-592, AIAA, June 1965.
9. Ragsdale, Robert G. ; and Edwards, Oliver J. : Data Comparisons and Photographic Observations of Coaxial Mixing of Dissimilar Gases at Nearly Equal Stream Velocities, NASA TN D-3131, 1965.
10. Ragsdale, Robert G. : Effects of Momentum Buffer Region on the Coaxial Flow of Dissimilar Gases. NASA TN D-3138, 1965.

11. Masser, Charles C.; and Taylor, Maynard F.: Photographic Study of a Bromine Jet in a Coaxial Airstream and Impinging on a Stagnation Surface. NASA TN D-5209, 1969.
12. Johnson, Bruce V.: Experimental Study of Multi-Component Coaxial-Flow Jets in Short Chambers. NASA CR-1190, 1968.
13. Mehta, Unmeel B.; and Lavan, Zalman: Flow in a Two-Dimensional Channel with a Rectangular Cavity. NASA CR-1245, 1969.
14. Rochino, Avelino P.; and Lavan, Zalman: Analytical Investigation of Incompressible Turbulent Swirling Flow in Pipes. NASA CR-1169, 1968.
15. Zawacki, Thomas S.; and Weinstein, Herbert: Experimental Investigation of Turbulence in the Mixing Region Between Coaxial Streams. NASA CR-959, 1968.
16. D'Souza, Gerard J.; Montealegre, Anthony; and Weinstein, Herbert: Measurement of Turbulent Correlations in a Coaxial Flow of Dissimilar Fluids. NASA CR-960, 1968.
17. Donovan, Leo F.; and Todd, Carroll, A.: Computer Program for Calculating Isothermal, Turbulent Jet Mixing of Two Gases. NASA TN D-4378, 1968.
18. Weinstein, Herbert; and Todd, Carroll A.: Analysis of Mixing of Coaxial Streams of Dissimilar Fluids Including Energy-Generation Terms. NASA TN D-2123, 1964.
19. Donovan, Leo F.: Similarity Solution for Turbulent Mixing Between a Jet and a Faster Moving Coaxial Stream. NASA TN D-4441, 1968.
20. Montealegre, Antonio; D'Souza, Gerard J.; and Weinstein, Herbert: Evaluation of Turbulence Correlations in a Coaxial Flow of Dissimilar Fluids. NASA CR-961, 1968.
21. Ghia, Kirti N.; Torda, T. Paul; and Lavan, Zalman: Laminar Mixing of Heterogeneous Axisymmetric Coaxial Confined Jets. IIT Research Inst. (NASA CR-72480), Nov. 1968.

22. Kao, Timothy W. : Concentration Profile Establishment of Binary Gas Mixture in Swirl and Duct Flows. NASA CR-399, 1966.
23. Williams, Peter M. ; and Grey, Jerry: Simulation of Gaseous Core Nuclear Rocket Mixing Characteristics Using Cold and Arc Heated Flows. NASA CR-690, 1967.
24. Rom, Frank E. : Nuclear-Rocket Propulsion. NASA TM X-1685, 1968.
25. Ragsdale, Robert G. ; and Lanzo, Chester D. : Some Recent Gaseous-Reactor Fluid Mechanics Experiments. Paper 69-477, AIAA, June 1969.
26. Lanzo, Chester D. : A Curved Porous Wall Gaseous Nuclear Reactor Concept. Trans. Am. Nucl. Soc. , vol. 12, no. 1, June 1969, pp. 2-3.
27. Lanzo, C. D. : Experimental Spectral Transmissivity of Carbon Particle Clouds. Proceedings of Nuclear Propulsion Conference, Naval Postgraduate School, Monterey, Calif. , Aug. 15-17, 1962. AEC Rep. TID-7653, pt. 1, July 1963, pp. 98-102.
28. Lanzo, Chester D. ; and Ragsdale, Robert G. : Experimental Determination of Spectral and Total Transmissivities of Clouds of Small Particles. NASA TN D-1405, 1962.
29. Masser, Charles C. : Radiant Heating of a Seeded Gas in a Coaxial-Flow Gaseous Reactor. NASA TN D-3197, 1966.
30. Masser, Charles C. : Vapor-Pressure Data Extrapolated to 1000 Atmospheres ($1.01 \times 10^8 \text{ N/m}^2$) for 13 Refractory Materials with Low Thermal Absorption Cross Sections. NASA TN D-4147, 1967.
31. Ragsdale, Robert G. ; and Einstein, Thomas H. : Two-Dimensional Gray-Gas Radiant Heat Transfer in a Coaxial-Flow Gaseous Reactor. NASA TN D-2124, 1964.

32. Lanzo, Chester D. ; and Ragsdale, Robert G. : Heat Transfer to a Seeded Flowing Gas from an Arc Enclosed by a Quartz Tube. 1964 Heat Transfer and Fluid Mechanics Institute. Warren H. Giedt and Solomon Levy, eds., Stanford University Press, 1964, pp. 226-244.
33. Lanzo, Chester D. : Coaxial-Flow Stabilization of an Alternating-Current Plasma Arc. Paper 68-706, AIAA, June 1968.
34. Lanzo, Chester D. : A Coaxial-Flow- Stabilized Arc. NASA TN D-4517, 1968.
35. Lanzo, Chester D. : Experimental Transmittance and Absorption Cross Sections of Carbon Particles Suspended in a Jet. J. Opt. Soc. Am., vol. 58, no. 12, 1968, pp. 1630-1633.
36. Lanzo, Chester D. : Measurement of the Transmissivity of a Carbon-Particle-Seeded Nitrogen Jet. NASA TN D-4722, 1968.
37. Taylor, Maynard F. : A Method of Correlating Local and Average Friction Coefficients for both Laminar and Turbulent Flow of Gases Through a Smooth Tube with Surface to Fluid Bulk Temperature Ratios from 0.35 to 7.35. Int. J. Heat Mass Transfer, vol. 10, Aug. 1967, pp. 1123-1128.
38. Taylor, Maynard F. : A Method of Predicting Heat Transfer Coefficients in the Cooling Passages of NERVA and PHOEBUS-2 Rocket Nozzles. Paper 68-608, AIAA, June 1968.
39. Parks, D. E. ; Lane, G. ; Stewart, J. C. ; and Peyton, S. : Optical Constants of Uranium Plasma. Rep. GA-8244, Gulf General Atomic (NASA CR-72348), Feb. 2, 1968.
40. Williams, J. R. ; Clement, J. D. ; Shenoy, A. S. ; and Partain, W. L. : The Attenuation of Radiant Energy in Hot Seeded Hydrogen. Quarterly Status Rep. 2, Georgia Inst. Tech., Eng. Experiment Station, 1969. (Grant NgR-11-002-068.)
41. Keng, Edward Y. H. ; and Orr, Clyde, Jr. : Investigation of Radiant Heat Transfer to Particle-Seeded Gases for Application to Nuclear Rocket Engine Design. NASA CR-953, 1967.

42. Kascak, Albert F.: Coaxial Flow Radiation Heat Transfer Analysis. Proceedings of an Advanced Nuclear Propulsion Symposium. Rep. LA-3229-MS, Los Alamos Scientific Lab., June 1, 1965, pp. 208-221.
43. Kascak, Albert F.: Estimates of Local and Average Fuel Temperatures in a Gaseous Nuclear Rocket Engine. NASA TN D-4164, 1967.
44. Kascal, Albert F.: The Effect of Turbulence on Radiant Heat Transfer in a Gaseous-Core Nuclear Rocket Engine. Am. Nucl. Soc. Trans., vol. 10, no. 1, June 1967, pp. 354-356.
45. Kascak, Albert F.; and Easley, Annie J.: Effect of Turbulent Mixing on Average Fuel Temperatures in a Gas-Core Nuclear Rocket Engine. NASA TN D-4882, 1968.
46. Ragsdale, Robert G.; and Kascak, Albert F.: Simple Equations for Calculating Temperature Distributions in Radiating Gray Gases. NASA TN D-5226, 1969.
47. Patch, R. W.: Effective Absorption Coefficients for Radiant Energy Transport in Nongrey, Nonscattering Gases. J. Quant. Spectrosc. Radiat. Transfer, vol. 7, no. 4, 1967, pp. 611-637.
48. Patch, R. W.: Approximation for Radiant Energy Transport in Nongray, Nonscattering Gases. NASA TN D-4001, 1967.
49. Patch, R. W.: Partition Function of the Morse Vibrating-Rotator Model of a Diatomic Molecule. J. Chem. Phys., vol. 47, no. 12, Dec. 15, 1967, pp. 5454-5455.
50. Patch, R. W.; and McBride, Bonnie J.: Partition Functions and Thermodynamic Properties to High Temperatures for H_3^+ and H_2^+ . NASA TN D-4523, 1968.
51. Patch, R. W.: Partition Functions of the Ground Electronic States of H_3^+ and H_2^+ . J. Chem. Phys., vol. 49, no. 2, July 15, 1968, pp. 961-962.

52. Patch, R. W.: Components of a Hydrogen Plasma Including Minor Species. NASA TN D-4993, 1969.
53. Patch, R. W.: Absorption Coefficients for Hydrogen. I. Composition. J. Quant. Spectrosc, Radiat. Transfer, vol. 9, no. 1, Jan. 1969, pp. 63-87.
54. Thorpe, Merle L.: Production of Superheated Hydrogen Plasma Using Induction Heating of Cold Plasma and DC Plasma Enhancement. NASA CR-657, 1966.
55. Thorpe, Merle L.: Induction Plasma Heating: System Performance, Hydrogen Operation and Gas Core Reactor Simulator Development. NASA CR-1143, 1968.
56. Thorpe, M. L.; and Scammon, L. W.: Induction Plasma Heating: High Power, Low Frequency Operation and Pure Hydrogen Heating. NASA CR-1343, 1969.
57. Hyland, Robert E.; Ragsdale, Robert G.; and Gunn, Eugene J.: Two-Dimensional Criticality Calculations of Gaseous-Core Cylindrical-Cavity Reactors. NASA TN D-1575, 1963.
58. Ragsdale, Robert G.; and Hyland, Robert E.: Some Nuclear Calculations of U^{235} -D₂O Gaseous-Core Cavity Reactors. NASA TN D-475, 1961.
59. Anon.: Gaseous-Fueled Cavity Reactors - Criticality Calculations and Analysis. NASA CR-487, 1966.
60. Lofthouse, J. H.; Pincock, G. D.; Kunze, J. F.; Wood, R. E.; and Hyland, R. E.: Cavity Reactor Critical Experiment. Am. Nucl. Soc. Trans., vol. 9, no. 2, Nov. 1966, p. 340.
61. Miraldi, Floro; Nelson, George W.; Holmberg, Gary; and Skoff, Gerald: Neutron Flux Distributions: (Experiment vs Theory) for a Water Reflected-Spherical Cavity System. Case Inst. Tech. (NASA CR-72231), Dec. 31, 1966.

62. Hyland, R. E.; Pincock, G. D.; Kunze, J. F.; and Wood, R. E.: Experimental Results from Large Cavity Reactor Critical. Am. Nucl. Soc. Trans., vol. 10, no. 1, June 1967, pp. 8-9.
63. Pincock, G. D.; and Kunze, J. F.: Cavity Reactor Critical Experiment, Vol. I. General Electric Co. (NASA CR-72234), Sept. 6, 1967.
64. Kunze, J. F.; Masson, L. S.; Pincock, G. D.; Wood, R. E.; and Hyland, R. E.: Cavity Reactory Gas-Core Critical Experiment. General Electric Co. (NASA CR-72329), Nov. 6, 1967.
65. Pincock, G. D.; Kunze, F. F.; Wood, R. E.; and Hyland, R. E.: Cavity Reactor Engineering Mock-up Critical Experiment. Rep. GESP-31, General Electric Co. (NASA CR-72409), May 22, 1968.
66. Pincock, G. D.; and Kunze, J. F.: Cavity Reactor Critical Experiment. Vol. II. Rep. GESP-35, vol. 2, General Electric Co. (NASA CR-72415), May 31, 1968.
67. Pincock, G. D.; and Kunze, J. F.: Cavity Reactor Critical Experiment. Vol. III. Rep. GESP-129, General Electric Co. (NASA CR-72384), Nov. 15, 1968.
68. Kunze, J. F.; Pincock, G. D.; and Hyland, R. E.: Cavity Reactor Critical Experiments. Nucl. Applications, vol. 6, no. 2, Feb. 1969, pp. 104-115.
69. Henderson, W. B.; Kunze, J.: Analysis of Cavity Reactor Experiments. NASA CR-72484, 1969.
70. Rom, Frank E.: Advanced Reactor Concepts for Nuclear Propulsion. Astronautics, vol. 4, no. 10, Oct. 1959, pp. 20-22, 46, 48, and 50.
71. Rom, F. E.; and Ragsdale, R. G.: Advanced Concepts for Nuclear Rocket Propulsion. NASA SP-20, 1962.

72. Ragsdale, R. G. ; and Rom, F. E. : NASA Research on the Coaxial Flow Gaseous Nuclear Rocket. Proceedings of Nuclear Propulsion Conference, Naval Postgraduate School, Monterey, Calif., Aug. 15-17, 1962.
73. Ragsdale, Robert G. : Performance Capability of Single-Cavity Vortex Gaseous Nuclear Rockets. NASA TN D-1579, 1963.
74. Ragsdale, Robert G. : Outlook for Gas-Core Nuclear Rockets. *Astronautics and Aerospace Eng.*, vol. 1, no. 7, Aug. 1963, pp. 88-91.
75. Ragsdale, Robert G. ; and Rom, Frank E. : Gas-Core Reactor Work at NASA Lewis. Paper 67-499, AIAA, July 1967.
76. Ragsdale, Robert G. : Are Gas-Core Nuclear Rockets Attainable? Paper 68-570, AIAA, 1968.
77. Luidens, Roger W. ; Burley, Richard R. ; Eisenberg, Joseph D. ; Kapproff, Jay M. ; Miller, Brent A. ; Shovlin, Michael D. ; and Willis, Edward R., Jr. : Manned Mars Landing Mission by Means of High-Thrust Rockets. NASA TN D-3181, 1966.
78. Anon. : Cavity Reactor Critical Experiment, Progress Report for Period January 1, 1969 through January 31, 1969. Rep. GEMP-667, General Electric Co., Feb. 13, 1969.

E-5015

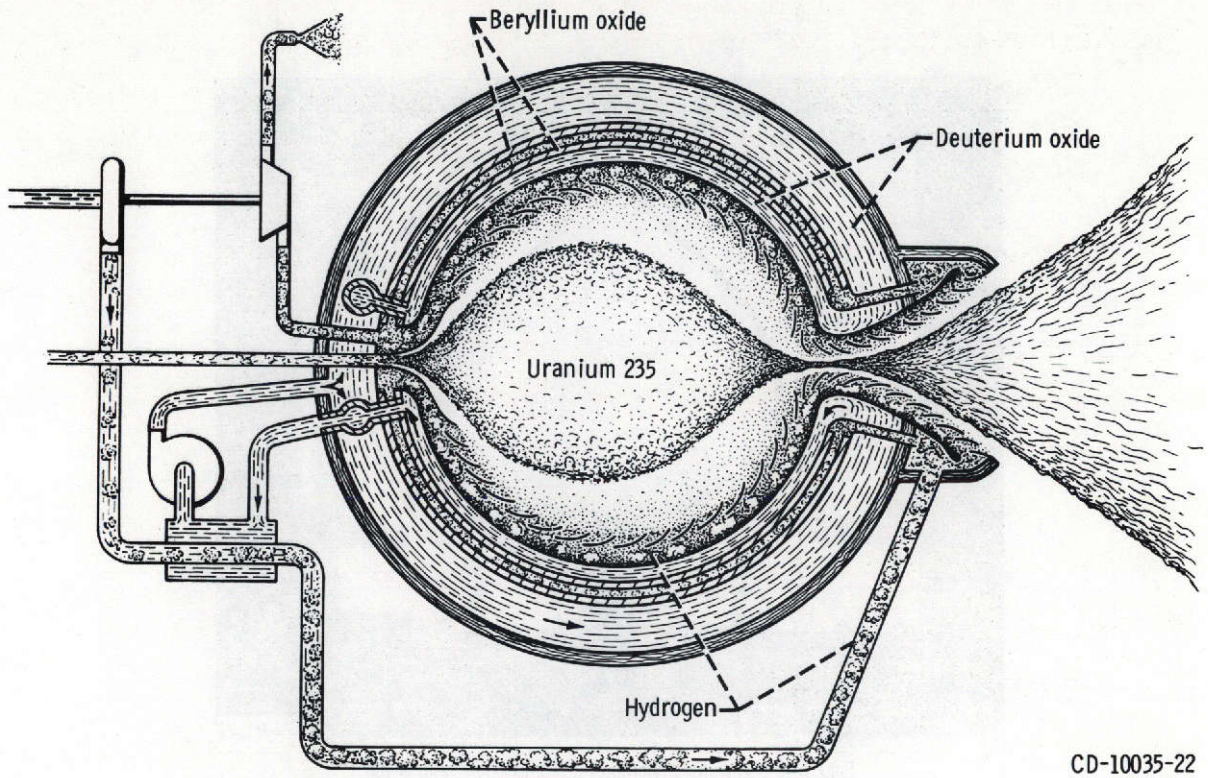

CD-10035-22

Figure 1. - Lewis gas core nuclear rocket concept.

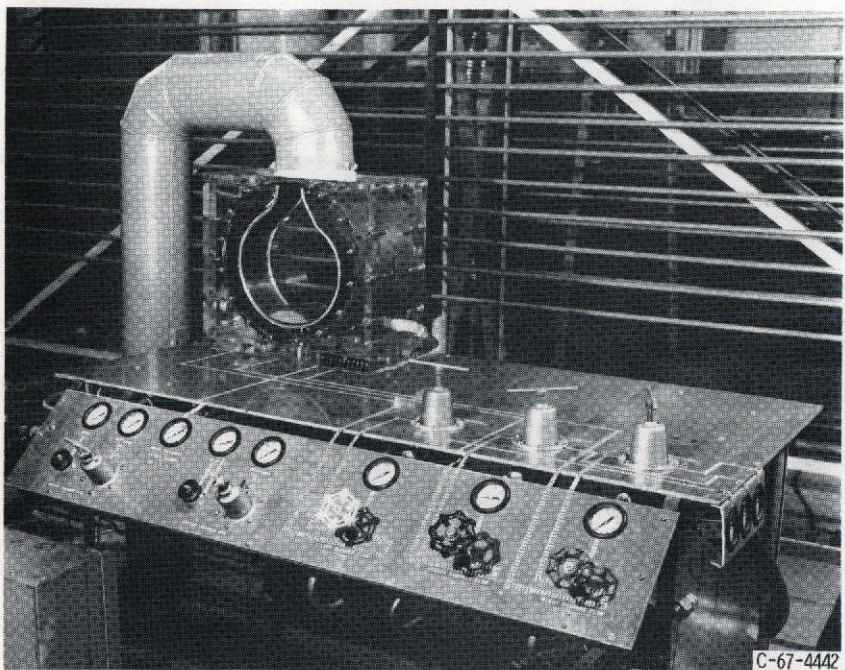

C-67-4442

Figure 2. - Two-dimensional experiment mockup of Lewis gas core concept.

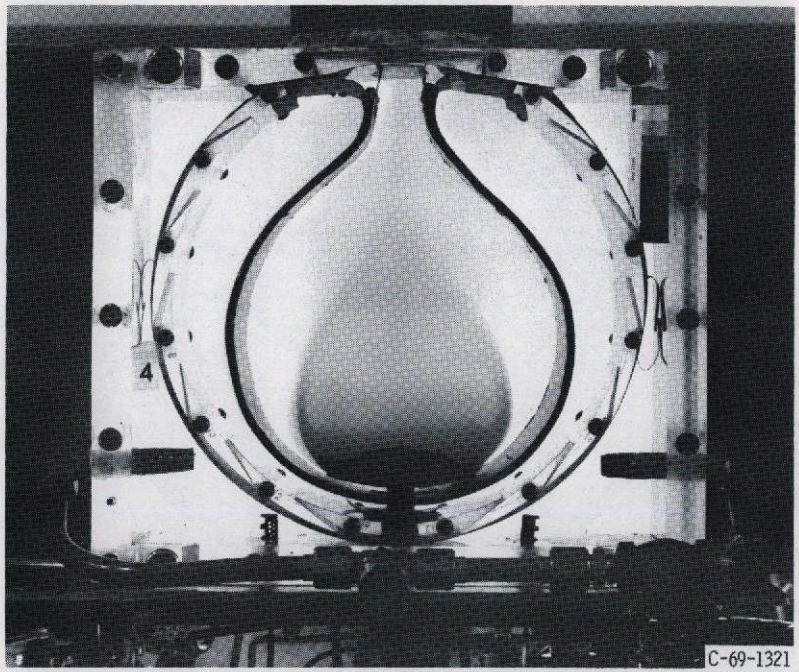

C-69-1321

Figure 3. - Two-dimensional flow at mass flow ratio of 100.

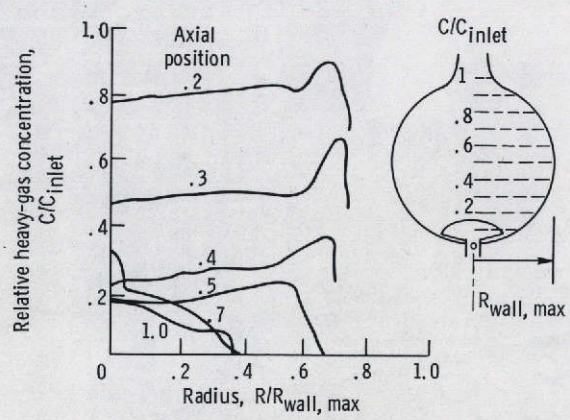
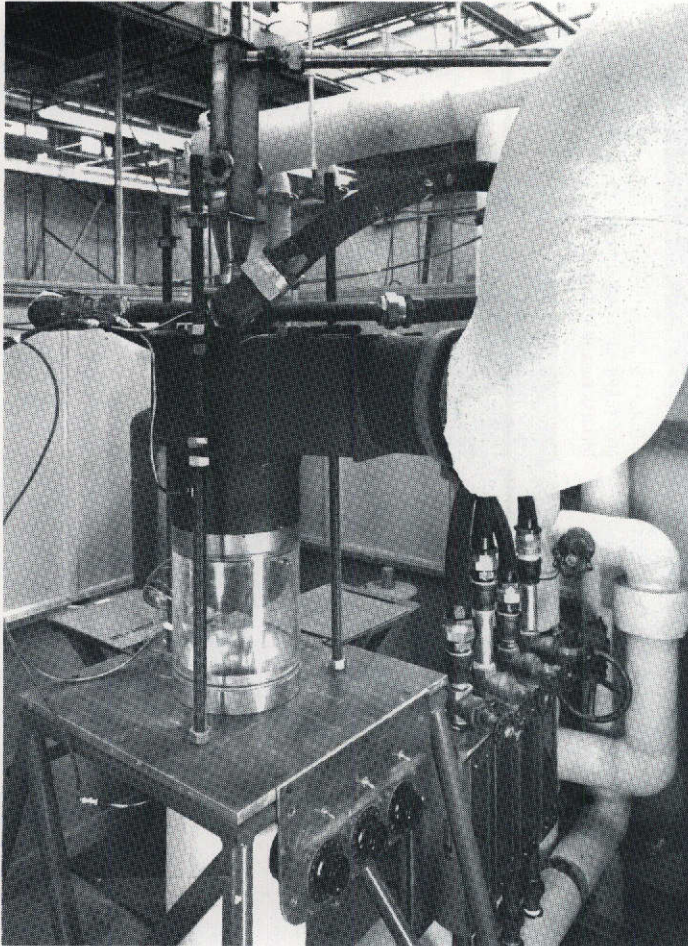
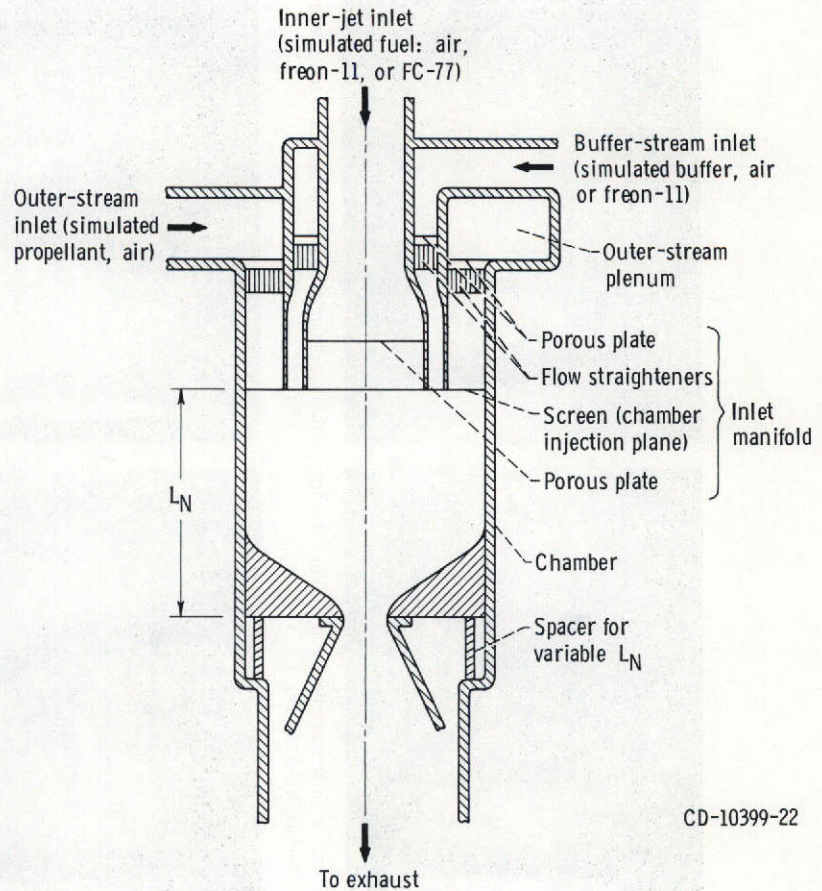

Figure 4. - Heavy-gas distribution in curved porous-wall apparatus at mass flow ratio of 100 to 1.



(a) Photograph of coaxial-flow test apparatus at UARL.



(b) Schematic of coaxial-flow test apparatus at UARL.

Figure 5. - Coaxial-flow test apparatus at United Aircraft Research Laboratories. Chamber diameter, D , 10 inches for all tests.

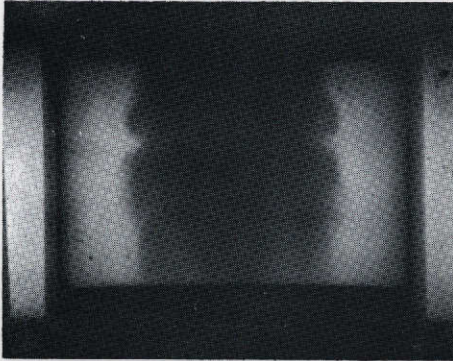

(a) Outer- to inner-mass-flow ratio of 30 to 1 showing good fuel-region containment.

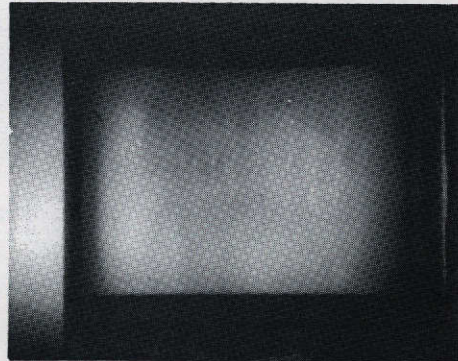

(b) Outer- to inner-mass-flow ratio of 55 to 1 showing very poor fuel-region containment.

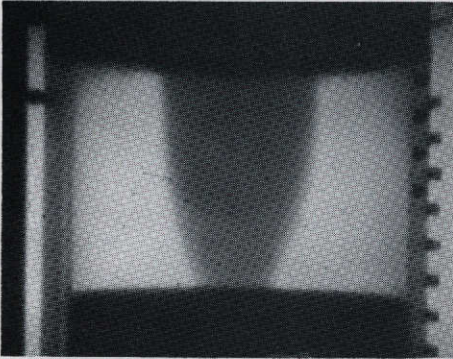

(c) Outer- to inner-mass-flow ratio of 30 showing good fuel-region containment; thick porous material across inlet face.

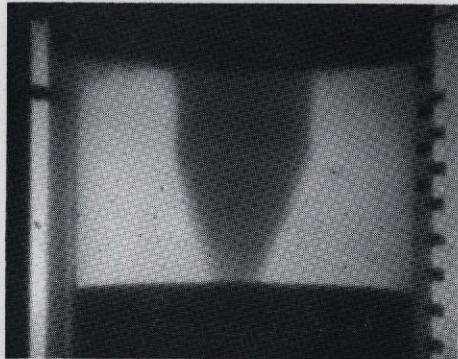

(d) Outer- to inner-mass-flow ratio of 80 showing good fuel-region containment; thick porous material across inlet face.

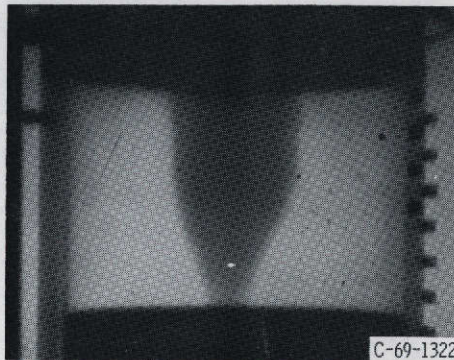

(e) Outer- to inner-mass-flow ratio of 130 showing good fuel-region containment; thick porous material across inlet face.

Figure 6. - Coaxial-flow experiment.

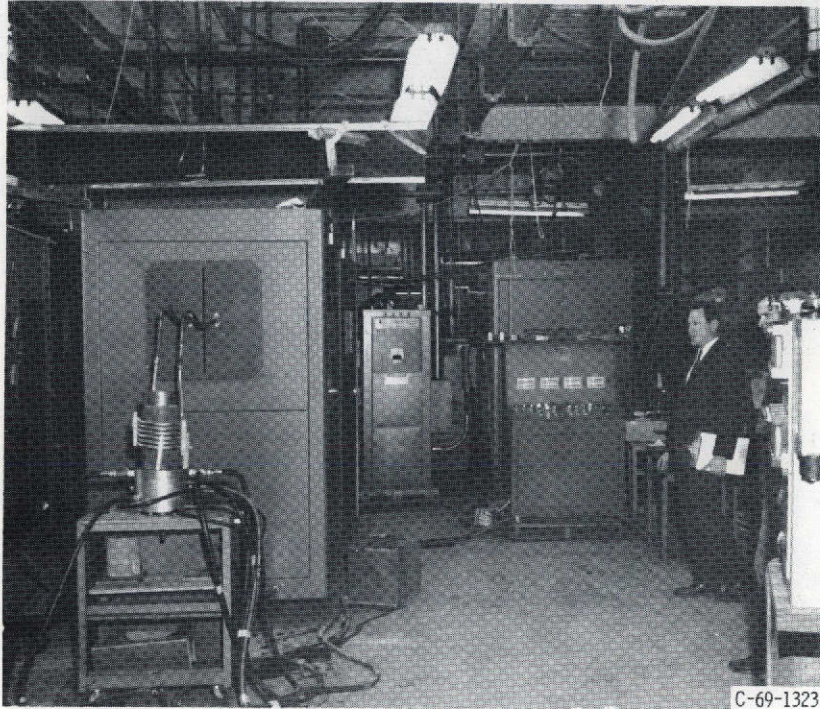

C-69-1323

Figure 7. - One-megawatt experiment.

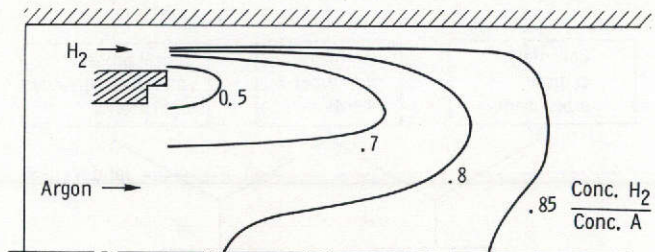

(a) Without heating.

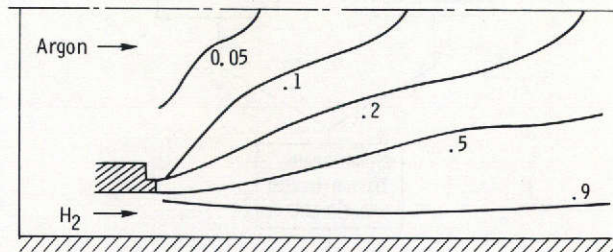

(b) With heating.

Figure 8. - Concentration profiles of coaxial flow of hydrogen and argon in radiofrequency torch.

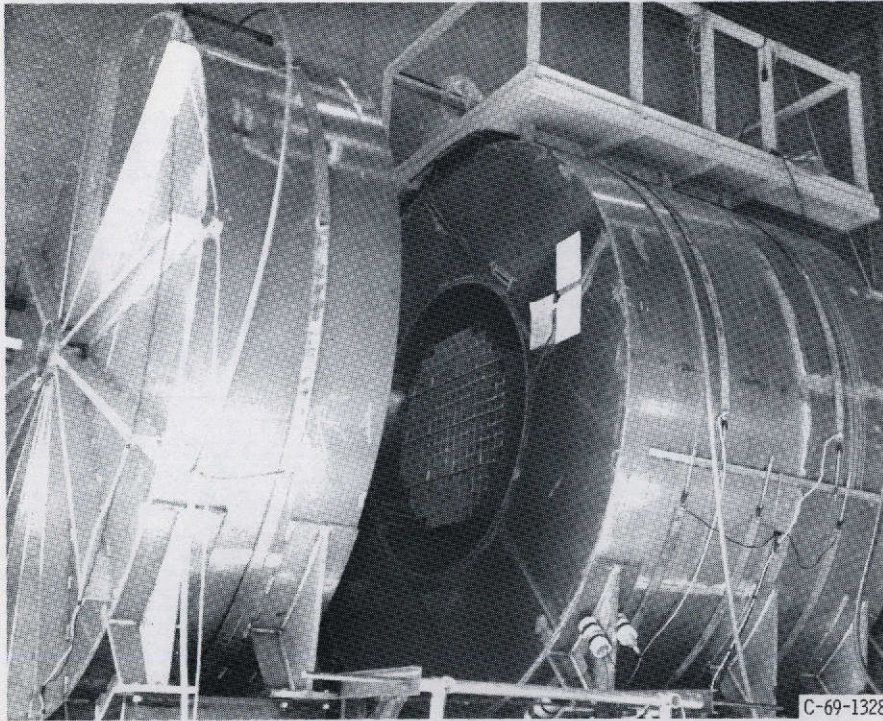

Figure 9. - Full-scale gas core critical experiment facility.

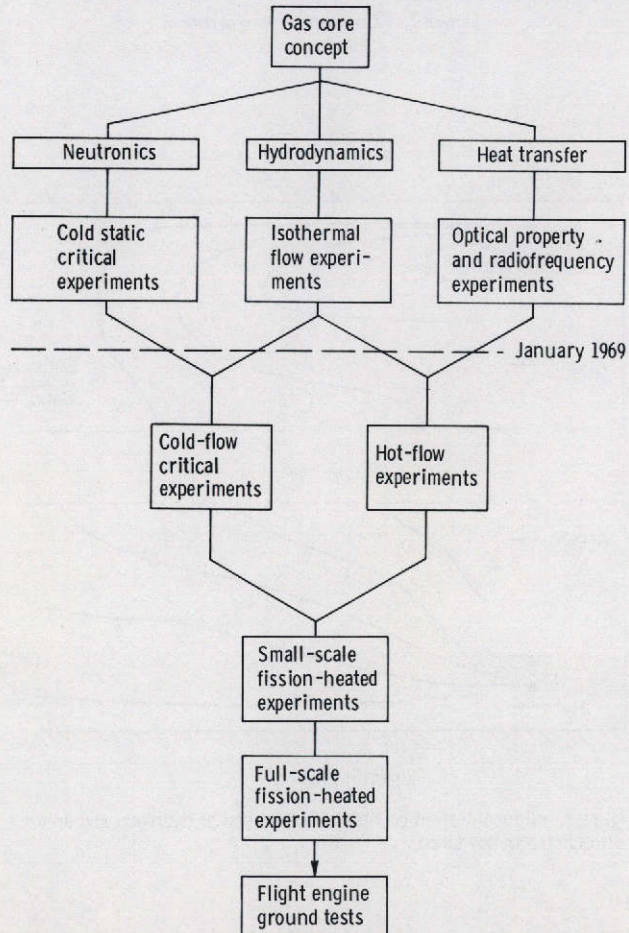

Figure 10. - Steps required to demonstrate gas core reactor feasibility.

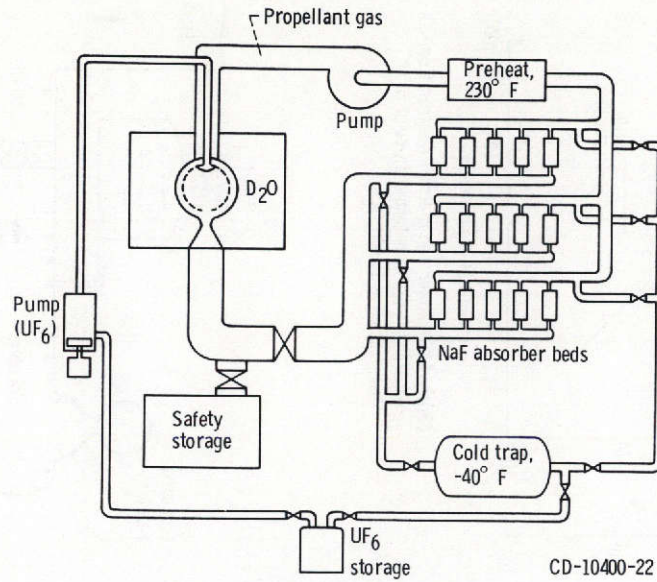

Figure 11. - Cold-flow critical experiment.

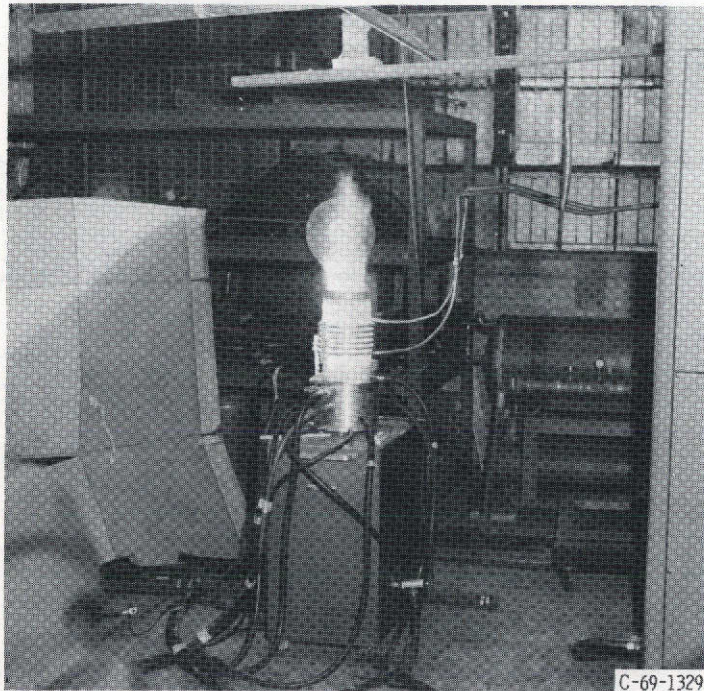
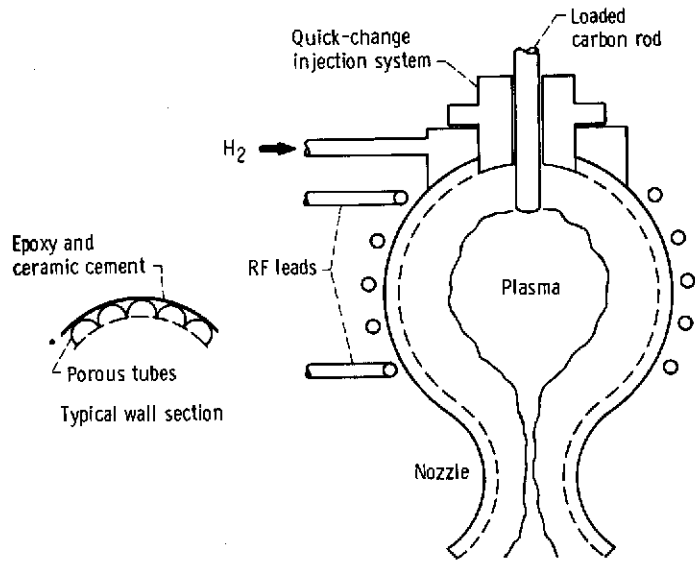

Figure 12. - Radiofrequency plasma torch operating at 500-kilowatt plate power with air.



CD-10401-22

Figure 13. - Radiofrequency (RF) hot-flow experiment.

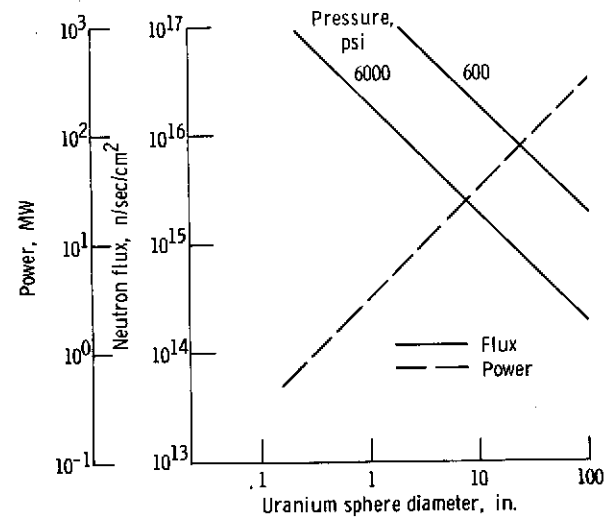
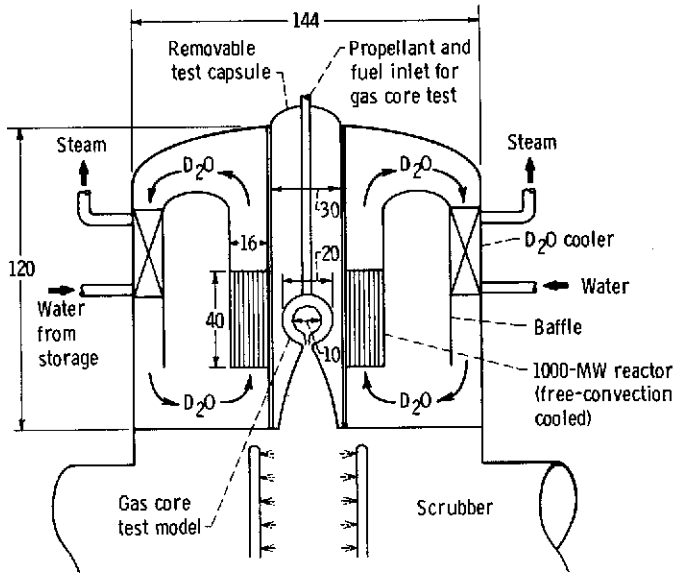

Figure 14. - Power and thermal neutron flux required to keep edge temperature of uranium plasma at 11 000° R.

38



CD-10402-22

Figure 15. - Small gas core test reactor. (Dimensions are in inches.)

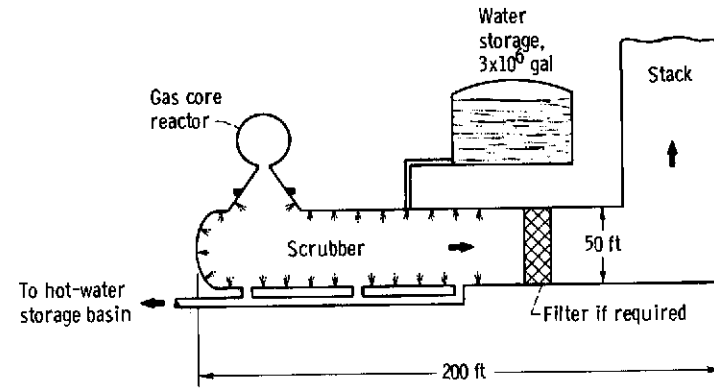

CD-10403-22

Figure 16. - Addition to test stand ETS-1 or test cell C at Nuclear Rocket Development Station required for 10 000-megawatt gas core test facility. Hydrogen and services supplied by existing systems.