

2. DEVELOPMENT OF AND DYNAMIC STUDIES CONCERNING

A CABLE BOOM SYSTEM PROTOTYPE

By G. Bring (ESTFC, Noordwijk, Holland)
G. Schmidt (Dornier System, Friedrichshafen, Germany)
D. Wyn-Roberts (B.A.C., Bristol, England)

SUMMARY

The conception of a cable boom system for a scientific spin stabilized satellite led to a flat cable stowed on a drum with a "flexlead without conversion" to avoid slip rings and to facilitate automatic restowage from any state of deployment. Some dynamic features of the extended cable boom and especially the comparison between round and flat cables were investigated in a "phenomenological" study using a test rig capable of inducing lateral, torsional and thermal cycling disturbances separately or in any combination.

INTRODUCTION

The use of cable booms on spin stabilized spacecraft has been foreseen, with the object of providing the electrical and structural connection with scientific experimental packages having to be placed away from the satellite body. The cables may have to contain several wires which may be arranged to form a round or a flat cable. The flat cable arrangement has certain advantages for the stowage and deployment devices.

A development program was therefore started to have designed, built and tested a cable boom system including a storage container for the undeployed cable, a deployment control unit and the cable itself. The philosophy of the programme was to have a realistic system designed and built and the most interesting characteristics of the system evaluated, thus forming a firm starting point for the developments to more strict specifications.

An experimental programme was launched in parallel in which the phenomenological possibility was studied of pure or coupled vibrations of the deployed cable. This was done over a range of cable sections and other parameter combinations. Cyclic disturbances of types that can be expected in the case of radial booms on a spinning spacecraft were introduced.

SYMBOLS

d_i inner diameter of cable drum
 d_a outer diameter of drum & cable
 n number of windings of cable
 s cable thickness
 N_D drum rotation speed

V cable deployment speed

L cable length

INVESTIGATION OF CABLE RESPONSE TO THERMAL AND MECHANICAL INPUTS

Introduction

A qualitative investigation of thermal and mechanical responses of cables was carried out in order to obtain data relevant to the behaviour of a cable boom on a spinning satellite. The study phases were as follows:

1. Definition of Test Parameters
2. Equipment Set-up and Check-out
3. Test Programme

Test Parameters

In the first place, it was necessary to choose suitable cables for testing. Three cables of different cross section were specified, their overall properties being based on the GEOS satellite requirements and defined so that thermal and mechanical responses would be exaggerated. The cables finally obtained are shown in Table 1 and consist of silver plated copper wires insulated by a polytetrafluoroethylene (P.T.F.E.) outer sleeving.

Table 1 TEST CABLES

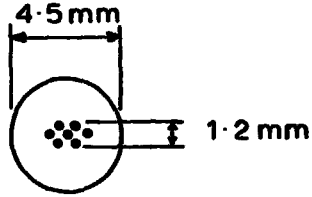
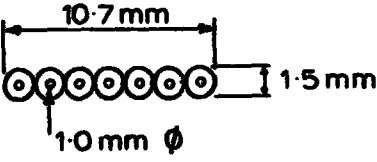
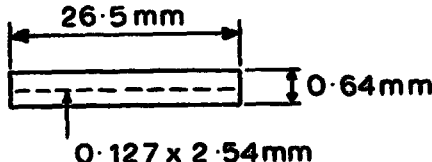
Cable Cross Section	Cross Sectional Area (mm ²)	Width/thickness Ratio
	16	1
	17.7	7.1
	16.8	41.8

An analysis of the thermal properties of these cables was carried out by means of a small computer programme. The analysis was mainly confined to steady state conditions. A selection of the results is given in Table 2.

Table 2 PRINCIPAL RESULTS OF THERMAL ANALYSIS

Cable type	Environment	Heat input (W/m ²)	Mean Temp (°C)	Temp Gradient (°C)	Comment
Circular cross section	Space	445	-51.1	0.7	
	Laboratory	445	43.2	0.7	
Ribbon cable "	Space	445	-134.0	23.9)	Edge on
	Laboratory	890	32.5	23.3)	to sun
Flat cable	Space	445	-177.7	12.3)	Edge on
	Laboratory	1780	25.9	11.7)	to sun
Flat cable	Space	560	-16.6	0.3)	Flat side
	Laboratory	560	55.9	0.7)	to sun

Note: all results for an α of 0.7 and ϵ of 0.8.

The highest required laboratory heat load is for the flat cable where, in the worst case, a heat input of 4 solar constants is required in order to obtain the equivalent (space) thermal gradient. The experimental heat lamps were subsequently designed to give this output.

The heating equipment itself consisted of two parabolic reflectors 3 meters high which could be placed on either side of the test cable. The heat is provided by banks of 1 kW tungsten-quartz tubes mounted along the reflector length at the focus of the parabola. Steady state or oscillating heating can be provided by these lamps, the heat output in the oscillating mode being sinusoidal. This output is controlled over the range 0 - 3Hz by means of an external oscillator operating via a 3-phase AC controller connected to a thyristor switching unit.

In order to provide the cable with mechanical inputs, a mechanism was devised capable of providing translatory oscillations in two perpendicular directions in the plane normal to the cable longitudinal direction, together with torsional oscillations. The oscillations could be provided separately or in any combination over the range .03-2.5Hz. Motor speed readout was provided by means of a photocell arrangement, and control by means of manually operated potentiometers.

Equipment Set-Up and Check-Out

The equipment was assembled in a test area with safety doors. Initially, the heat output from the arrays was calibrated under steady state conditions using thermoplates. Fig. 1 shows the measured heat intensity distribution along the cable position. This was the most even distribution possible within the programme restraints and was achieved by a combination of re-distribution of lamps and tilting of the arrays.

Prior to each test, a disk-shaped mass of 1 kg was clamped to the end of the test cable. The mass was chosen on the basis of the calculated centrifugal force experienced by the satellite cable boom in orbit, whereas the inertia was chosen in order to produce a low torsion frequency and maximise the cross

coupling with the thermal inputs.

Test Programme

The test programme consisted of a parametric study of thermal and mechanical responses of the cables. The mechanical inputs were 15° for torsion and 16mm for lateral oscillations. Torsional output amplitude was measured by noting the position of scribed lines on the tip mass whereas lateral amplitudes were measured by viewing a grid scribed on a reflecting plate and placed below the cable.

The principal results were as follows:

- .. All cables exhibited well defined mechanical resonance characteristics. This can be seen from Fig. 2, for example, which shows the torsion resonances measured for all 3 cables. Further very high amplitude magnification was recorded, ranging from 9 to 30 for the torsion mode and 80 to 180 for the lateral modes.
- .. No induced movement could be achieved in any cables solely as a result of thermal inputs.
- .. The natural torsion frequencies of all cables were reduced by between 10% to 30% as a result of heat inputs.

Conclusions

The high amplitude magnifications, particularly for lateral oscillations, show that the intrinsic damping characteristics of the cables are very small. Also, the changes in natural torsional frequency with temperature indicate that quite a wide range of natural frequencies will be experienced in space, since the temperature will have an even larger variation than that experienced during our tests. The introduction of artificial damping is, therefore, of prime importance.

Finally, since no cable movements were induced as a result of oscillatory heat inputs only, despite the fact that an exaggeration of the conditions for inducing thermal gradients was aimed for in the tests, then the improvements in damping effects induced by the added damper should virtually eliminate any concern due to this effect.

DEVELOPMENT OF A CABLE BOOM MECHANISM

Introduction

A cable boom mechanism study was conducted in parallel with the investigation of cable response. The objective was to design a cable boom system, including storage container, development control unit and the cable itself, such that the system could be built and tested and exhibit a high degree of reliability. The design had to take into account the following constraints:

- .. The mechanism had to stow and deploy at least 10m of cable boom.
- .. It should be possible to stop the boom at any stage of deployment.
- .. No slip rings should be used.
- .. At least one metre of the end of the boom had to have a circular cross section.

System Study

This consisted, essentially, of an examination of system variations for one basic solution - that is, a cable stowed on a rotatable drum. A flat cable boom was chosen because of its compact stowage characteristics. The requirements could be met by using 6 coaxial wires plus one central load wire surrounded by shielding and outer insulation. This arrangement could readily be converted to circular cross-section cable over the final 1 metre of length and is illustrated in Fig. 3.

The main problem with the rotating drum solution is the electrical connection. The latter was studied from the point of view of both a retractable and a non-retractable system.

Non-Retractable System

The electrical signals can be taken from the cable boom by means of a flexible cable, termed a flexlead, which can be positioned inside or next to the drum. For the non-retractable system, flexlead length can be minimised by using the conversion technique. The flexlead is backwound on the central shaft and unwinds during boom deployment. After passing the conversion point, it then rewinds onto the shaft in the opposite sense. The same cable could be used for both boom and flexlead.

Deployment can be performed by motor driven gears. Both a worm gear and a spur gear drive were considered. The worm gear has a self-locking capability and requires the motor power of about 3 watts during deployment. The spur gear solution is relatively straightforward but requires an auxiliary braking device. The power required by the motor would be about 12 watts and would cause more magnetic disturbance than the previous solution.

Retractable System

This imposes more stringent requirements on the flexlead, because it must work reliably in both directions. Tests were carried out on various configurations and the preferred solution was a single stage flexlead without conversion. This requires additional flexlead length so that, in order to minimise mass and volume, it is preferable not to use the cable boom cable itself as the flexlead but to use a special flexlead cable. This system has been successfully tested.

For the deployment drive unit, the retraction forces are higher than the deployment forces. Peak output motor power required would be 20W for the worm gear and 15W for the spur gear. The motor output power can be decreased by reduction of the retraction speed. The latter can be achieved by gear switching or by utilisation of induction motors with sharply decreasing torque/rotational speed characteristics.

Detailed Design Study

The retractable system was chosen for the detailed design study because this feature was considered desirable for ground testing. During this phase, detailed analysis of the various components was undertaken in order to provide

final dimensions to enable manufacturing drawings to be produced. The final drawing of the complete mechanism is given in Fig. 4.

For the flexlead, a stranded flat ribbon cable 0.7mm thick was chosen capable of being wound on an inner diameter of 25mm. A total length of 6.8m of flexlead was required for 10m of cable boom and its total weight is 102 g.

For the cable drum, a minimum diameter of 100mm, for 10m of cable, was calculated, the outer diameter of drum + cable being 200mm. For a constant drum rotation speed, the deployment speed of the cable will vary. However, no correction was made for this since the speed variation was within an acceptable range. Optimisation of the drum parameters was achieved by using the following drum equations:

1. $d_i + 2.n.s. = d_a$
2. $d_a \leq 2 d_i$ (If $N_D \approx \text{const}$ and $V_{\text{max}} \geq V_{\text{min}}$)
3. $(d_i + d_a) \pi/2 = L$

The motor driven worm gear system was chosen for the drive. Sizing was based on the expected cable loads during deployment as shown in Fig. 5. This led to the choice of a Clifton Ash size 11 two phase A.C. motor of 27×10^{-3} Nm (4 oz-in.) stall torque and speed of 12000 r.p.m. together with a sterling size 11 gearhead. The pitch diameter of the worm gear was 18mm with a pitch angle of 8° . An A.C. motor was chosen because of electromagnetic cleanliness requirements, the remanent magnetic field being at least a factor of 10 better than for D.C. motors.

Dry lubricants and dry lubricated materials were used throughout.

The unit was successfully built and has undergone vacuum testing on the facility illustrated in Fig. 6.

Conclusions

A mechanism for storage and deployment control of a cable boom was successfully developed and tested.

A phenomenological study of cable boom vibrations indicated that some supplementary damping is most desirable.

A problem that has to be investigated for a certain geostationary scientific satellite application of the cable boom concept is the development of a cable that will withstand the severe radiation and eclipse thermal environments.

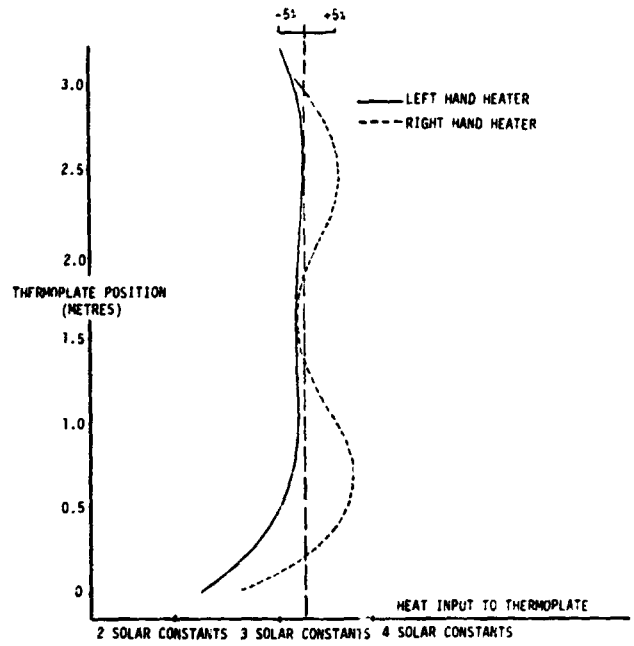

Figure 1.- Heat intensity distribution along length of cable position for both arrays.

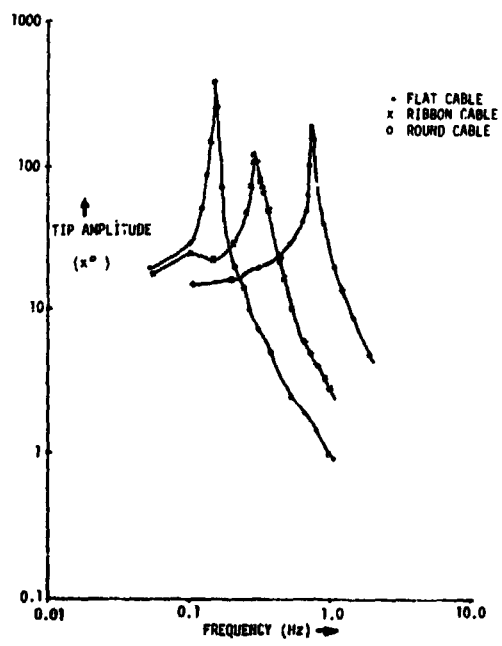
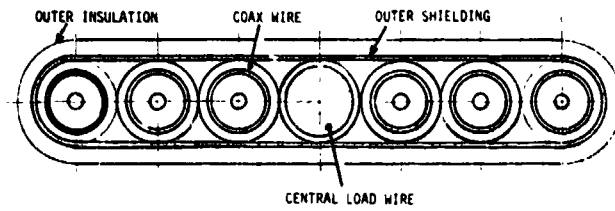
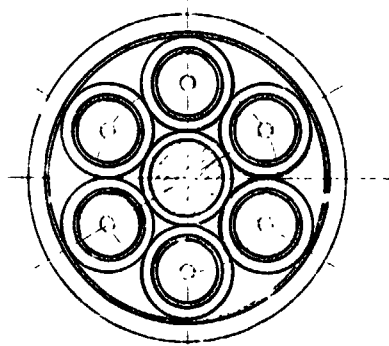

Figure 2.- Torsion resonance plots for three cable types. (Input amplitude, 15°).



(a) Flat arrangement.



(b) Round arrangement.

Figure 3.- Cable cross section.

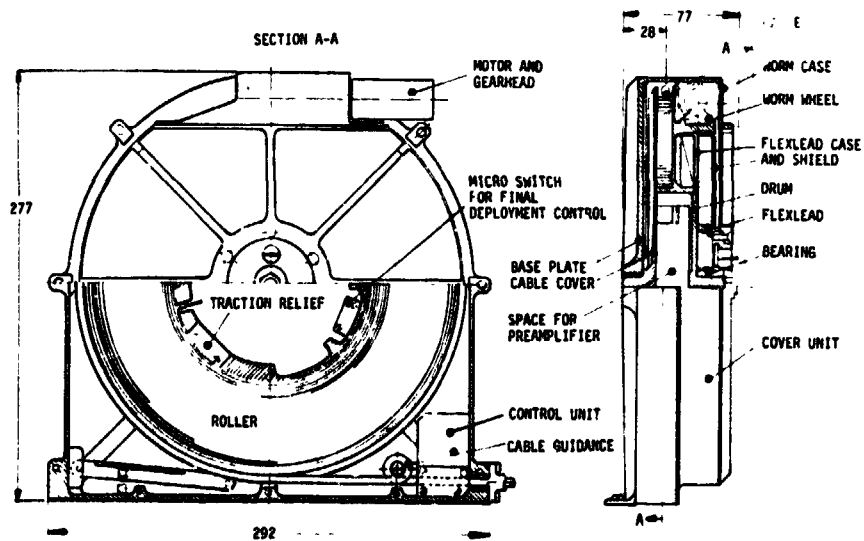

Figure 4.- GEOS cable boot system.

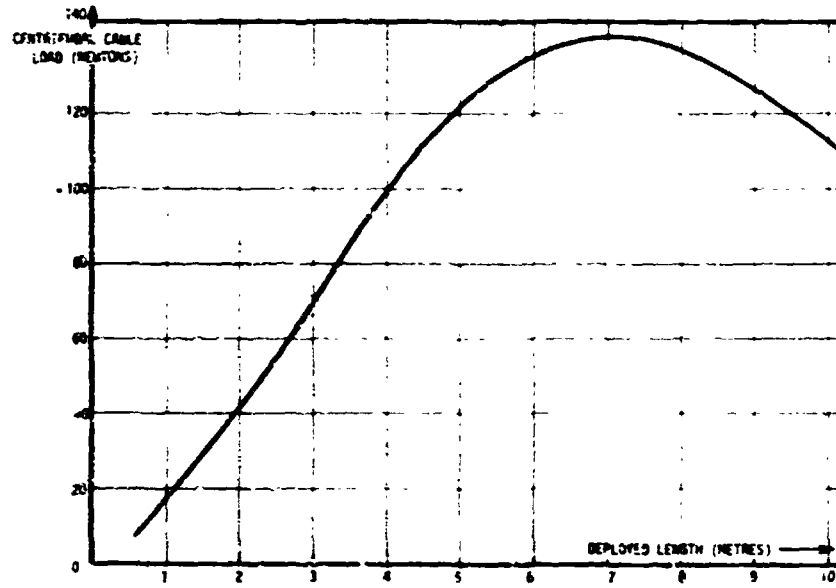

Figure 5.- Cable load during deployment.

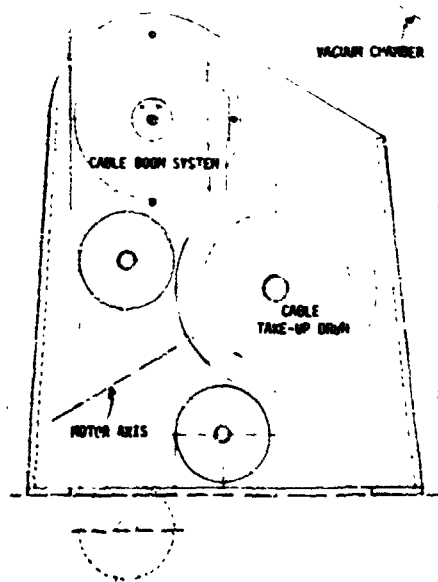

Figure 6.- Vacuum test facility.