

SYSTEMS DESIGN INSTITUTE

NASA GRANT NGT 44-005-114

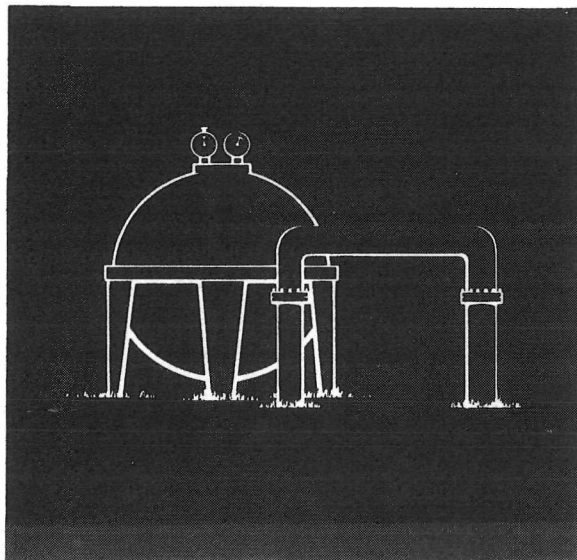
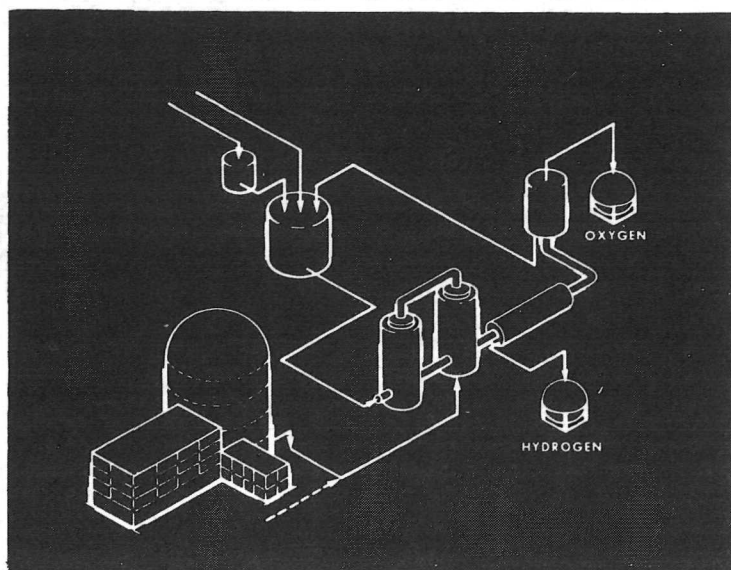

A HYDROGEN ENERGY CARRIER

VOLUME II
SYSTEMS ANALYSIS

1973
NASA-ASEE

(NASA-CR-134176) A HYDROGEN ENERGY
CARRIER. VOLUME 2: SYSTEMS ANALYSIS
(Houston Univ.) 158 p HC \$10.00

N74-11728
THRU
N74-11735
Unclas
21144

CSCI 20M

G3/33

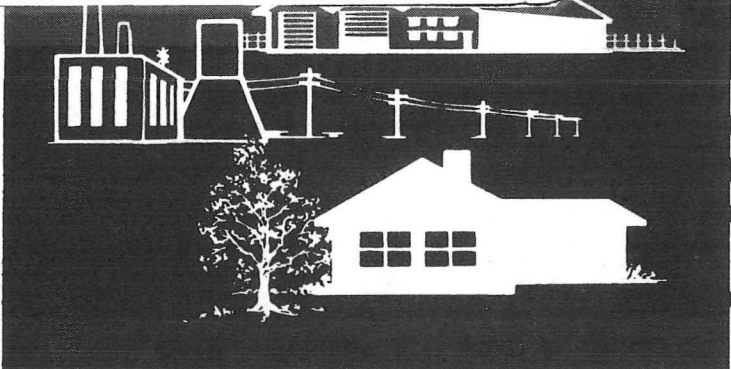

A HYDROGEN ENERGY CARRIER
VOL. II - SYSTEMS ANALYSIS

September, 1973

EDITORS:

Robert L. Savage

Lee Blank
Tom Cady
Kenneth Cox
Richard Murray
Richard Dee Williams

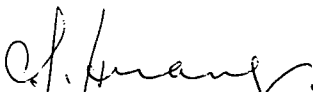
C. J. Huang, Co-Director
University of Houston

Barbara K. Eandi, Co-Director
NASA-Johnson Space Center

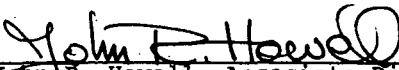
John R. Howell, Associate Director
University of Houston

W. Richard Downs, Technical Director
NASA-Johnson Space Center

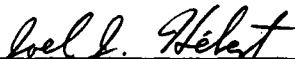
Joel J. Hebert, Assistant Director
Rice University

WILEY-INTERSCIENCE

AUTHORS

Dr. Leland T. Blank	University of Texas at El Paso
Prof. Thomas C. Cady	University of Houston
	and West Virginia University
Dr. Raul E. Chao	University of Puerto Rico
Dr. Kenneth E. Cox	University of New Mexico
Dr. Melvin M. Eisenstadt	University of Puerto Rico
Dr. Richard T. Johnson	University of Missouri at Rolla
Dr. Harold A. Koelling	Mississippi State University
Dr. Samuel S. Lee	University of Miami
Dr. Richard G. Murray	Oklahoma State University
Dr. Stamatis N. Paleocrassas	Tri-State College
Prof. Samuel O. Powers	Oklahoma State University
Dr. Richard K. Riley	University of Missouri at Rolla
Dr. Jack D. Salmon	Virginia Polytechnic Institute
Dr. Robert L. Savage	Ohio University
Dr. Leonard A. Traina	New Mexico State University
Dr. Richard D. Williams	University of Arizona
Dr. Albert E. Wilson	Idaho State University
Dr. Jeffrey G. Witwer	University of Oklahoma

PRECEDING PAGE BLANK NOT FILMED

Page Intentionally Left Blank

ABSTRACT

A systems analysis of hydrogen as an energy carrier in the United States indicated that it is feasible to use hydrogen in all energy use areas except some types of transportation. These use areas are industrial, residential and commercial, and electric power generation. Saturation concept and conservation concept forecasts of future total energy demands were made. Projected costs of producing hydrogen from coal or from nuclear heat combined with thermochemical decomposition of water are in the range \$1.00 to \$1.50 per million Btu of hydrogen produced. Other methods are estimated to be more costly. The use of hydrogen as a fuel will require the development of large-scale transmission and storage systems. A pipeline system similar to the existing natural gas pipeline system appears practical, if design factors are included to avoid hydrogen environment embrittlement of pipeline metals. Conclusions from the examination of the safety, legal, environmental, economic, political and societal aspects of hydrogen fuel are that a hydrogen energy carrier system would be compatible with American values and the existing energy system.

PRECEDING PAGE BLANK NOT FILMED

TABLE OF CONTENTS

<u>CHAPTER</u>	<u>TITLE</u>	<u>PAGE</u>
1.	SUMMARY	1
2.	INTRODUCTION	7
2.1	Overall Energy Picture	7
2.2	The Fossil Fuel Cycle	7
2.3	A Hydrogen Fuel Cycle	7
2.4	Our Energy Use	77
2.5	Why Hydrogen?	10
2.6	Other Work On Hydrogen	11
3.	PRODUCTION OF HYDROGEN	15
3.1	Introduction	15
3.2	Discussion of Methodology	15
3.3	Sources	16
.1	Solar Energy	16
.2	Wind Energy	17
.3	Fossil Energy	19
.4	Nuclear Energy	20
.5	Miscellaneous	21
3.4	Conversion Processes	24
.1	Electrolysis of Water	24
.2	Thermochemical Decomposition of Water	27
.3	Photolysis of Water	39
.4	Direct Thermal Splitting of Water	41
3.5	Conversion Paths	43
.1	Solar Energy Paths	43
.2	Wind - Electrolysis Path	47
.3	Fossil Energy Paths	47
.4	Nuclear Energy Paths	49
3.6	System Alternatives for Hydrogen Production	50
.1	Nuclear Power - Electrolysis	51
.2	Nuclear Heat - Thermochemical Decomposition	52
.3	Solar Heat - Thermochemical Decomposition	53
.4	Wind - Electrolysis	53
.5	Coal Gasification	54
.6	Comparison of Results	54
4.	TRANSMISSION AND STORAGE OF HYDROGEN	63
4.1	Introduction	63
4.2	A Gaseous Hydrogen/Natural Gas System Comparison	63
.1	A Hydrogen Fuel System	63
.2	The Existing Natural Gas System	63
.3	Existing Hydrogen Handling Systems	65
.4	Economics of Transmission	65
.5	A Hydrogen Pipeline System	65
.6	Potential Hydrogen Embrittlement	66
4.3	Liquid Hydrogen	67
.1	Technology of Liquefaction and Storage	67
.2	The Role of Liquid Hydrogen	68
.3	The Energy Pipe	69
.4	Peak Shaving Facility	70
.5	The Small Town	71
4.4	Solid Hydrides	73
.1	Mechanism of Storage	73
.2	Advantages and Disadvantages of Hydride Storage	74
.3	Economics	74
4.5	Conclusions	75
5.	USAGE OF HYDROGEN	79
5.1	Introduction	79
.1	Usage of Energy	79
.2	Demand for Energy	80

<u>CHAPTER</u>	<u>TITLE</u>	<u>PAGE</u>
5.2	Hydrogen Utilization Devices	82
.1	Water Modified H ₂ -O ₂ (Aphodid) Burner	82
.2	Hydrogen Fueled Internal Combustion Engine	84
.3	Catalytic Burners	87
.4	Flame Burners	88
.5	Fuel Cells	89
.6	Other Devices	91
5.3	Hydrogen Utilization Devices	91
.1	Residential and Commercial Use	91
.2	Industrial - Fuel Usage	94
.3	Transportation Usage	96
.4	Electric Power Generation	105
.5	Industrial-Chemical Usage	108
5.4	Compatibility of Hydrogen With Engineering Metals	109
5.5	System Implementation	111
.1	Conversion Sequence	111
.2	Impact of System Implementation	112
5.6	Conclusions	112
G.	SAFETY, LEGAL, ENVIRONMENTAL, ECONOMIC, POLITICAL, AND SOCIAL ASPECTS OF HYDROGEN	119
6.1	Introduction	119
6.2	Safety Implications	119
.1	Legal Aspects	119
.2	Political Aspects	121
.3	Description and Assessment	122
6.3	Legal Implications	124
.1	Energy Law	124
.2	Regulatory Law	126
.3	Environmental Law	128
.4	International Law	130
6.4	Environmental Implications	132
6.5	Socio-Economic Implications	133
.1	Introduction	134
.2	Social Costs and Values	134
.3	Energy and the Social Future	135
.4	Economic Costs	136
.5	Hydrogen and Society	137
.6	Conclusion	138
6.6	Political Implications	138
.1	Politics and Energy	138
.2	The Near Future (1975-1985)	139
.3	International Politics	140
.4	Domestic Politics	141
.5	Conclusion	142
6.7	Conclusions	142
7.	IMPLEMENTATION OF A HYDROGEN ENERGY CARRIER SYSTEM	149
7.1	Possibilities for Implementation	149
7.2	General Considerations	149
7.3	Implementation by Stages	149
.1	Stage I - Coal Gasification Project	149
.2	Stage II - Hydrogen Via Nuclear Power	150
.3	Stage III - Model Hydrogen City	150
.4	Stage IV - Model Hydrogen Society	150
7.4	Long Range Recommendations	150
	APPENDICES	
	A. Properties of Hydrogen	155
	B. Systems Analysis	159
	C. Participating Fellows, Guest Speakers, and Other Contributors	167

CHAPTER 1

SUMMARY

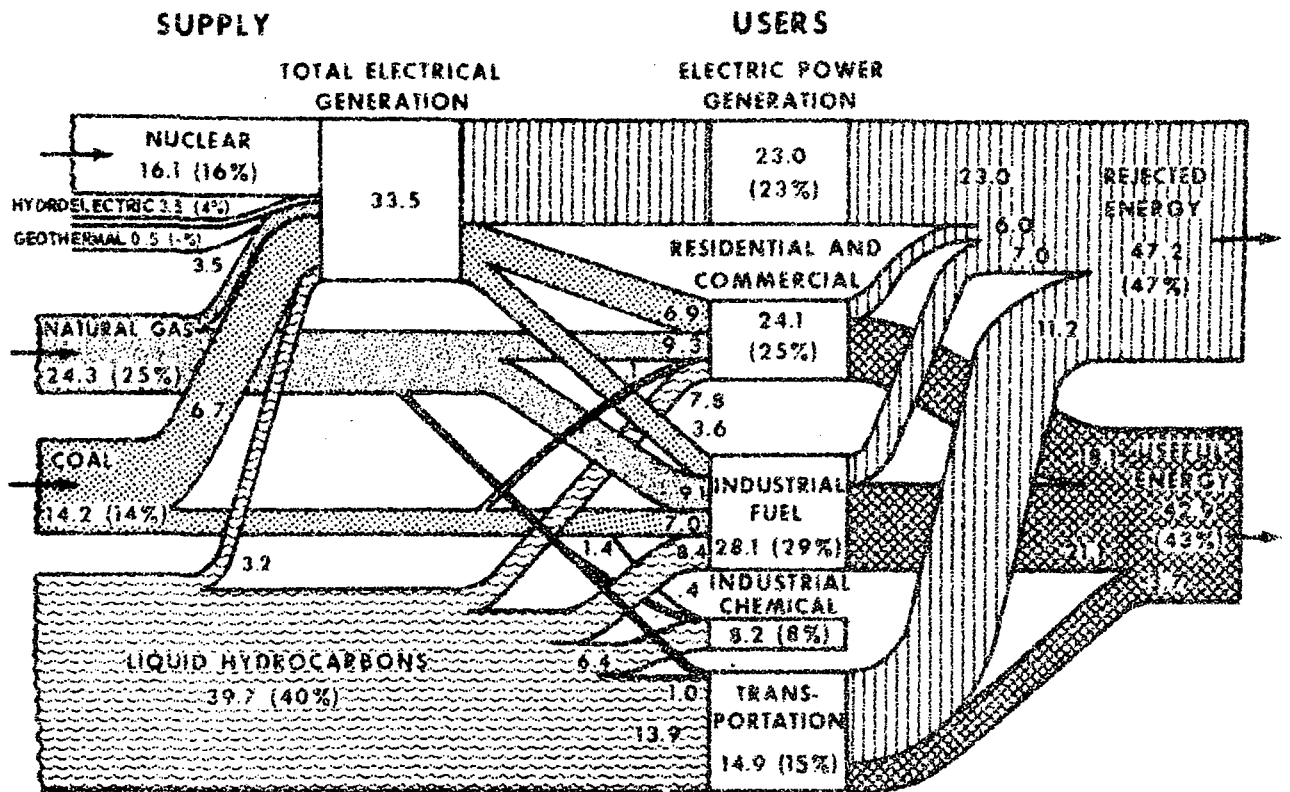

(ALL VALUES ARE $\times 10^{15}$ BTU - TOTAL U.S. DEMAND = 98.3×10^{15} BTU)

A conservative study of the demand for energy in the United States indicates a doubling of the consumption from the year 1970 to the year 2000. At the present time most of this energy is derived from fossil fuels that have a finite reserve. To conserve these fossil sources and retain the present standard of living, a synthetic fuel derived from a renewable primary energy source must be used. Hydrogen, a fuel that can be produced from water, appears to be the answer.

Hydrogen is compatible with all of the fuel needs of society with one exception; on-board storage difficulties prevent practical consideration of hydrogen's usage in automotive-type vehicles within the foreseeable future. Industry can use hydrogen in the form of fuel wherever fossil sources are now used. The industrial-chemical hydrogen usage pattern will not be altered except that the input to the chemical process will be pipelined hydrogen rather than natural gas. Residential and commercial usage of hydrogen appears feasible and practical especially in new buildings. The changeover of existing small structures to hydrogen, however, will be difficult due to high cost. The use of hydrogen as a fuel in electric power generation facilities appears highly feasible.

The physical and chemical characteristics of hydrogen make it a nearly ideal synthetic fuel. These characteristics include:

- Wide flammability limits that permit combustion in the low nitric oxide emitting fuel-air ratios.
- Low ignition energy that permits more flexibility in the choice of ignition sources.
- High diffusion rate which permits dilution to nonflammable mixtures very quickly.
- Nontoxic and nonpolluting exhaust products.

The handling and safety considerations for gaseous hydrogen appear to be no more complex than for any high energy fuel. Society should adapt to its use with reasonable guidance, information and time. Nuclear, solar, wind, fossil energy and ocean thermal gradients, have been analyzed as sources of energy for producing hydrogen by various methods. The electrolysis of water and the gasification of coal are in commercial operation today. Closed-cycle thermochemical water decomposition is rapidly being developed due to its promise for attaining high energy conversion efficiencies.

No one method or system for hydrogen production was found to be optimum. In

the near future, 1975 to 1985, coal gasification with steam will be used to produce synthetic natural gas or synthetic oil crude from large coal deposits in the United States using new technology that is being developed. Estimated costs for methane from this process are in the range \$1.00 to \$1.50 per million Btu. Costs of hydrogen from coal are projected to be in the same range. Avoiding the problems of conversion to another fuel favors the production of methane rather than hydrogen from coal.

The alternative, nuclear heat - thermochemical closed-cycle decomposition of water, was found very promising for the period after 1985 if theoretically predicted efficiencies of 50 to 60 percent are achieved. This process has not yet been demonstrated in practice, but holds great promise since it avoids the costs and inefficiencies of producing electricity. Many multistep thermochemical schemes of this type were considered. Nuclear power combined with electrolysis for making hydrogen was examined in great detail because it is a commercially operating process. Present electrolysis efficiencies run at 60 to 70 percent, based on the ratio of hydrogen fuel value to electrical input. A combination of increased efficiency and lower capital cost may result from advanced electrolyzer technology with possibly 100 percent efficiency by the year 2000. Even with these advances, and development of homopolar generators to supply low voltage direct current, the cost of hydrogen will remain between \$2.00 and \$2.50 per 10^6 Btu at an electricity cost of 7 mills per kWh. The basic cost of electricity on which electrolytic plants depend is not expected to decrease and probably will increase, making this method less attractive. Solar heat combined with closed-cycle thermochemical decomposition of water and wind power combined with electrolysis were also investigated as alternatives. Cost estimates for both cases were less favorable than for nuclear power-electrolysis. In the case of solar energy, the reasons are the low intensity of the solar radiation and its intermittency. These give rise to large capital costs for energy generation.

Wind, which is solar in origin, has the same problems associated with it; however, shaft horsepower is directly attainable to generate direct current electricity for water electrolysis. Both of these alternatives are possibilities for the time period beyond 1985 and demonstration plants are recommended.

Photolysis, photobiosynthesis or other exotic methods of hydrogen production should not be totally discounted. Many technical and scientific problems require solution before these methods can

become technically and economically viable. Photolysis suffers the same problems as those encountered in solar energy plus the need for, as yet, a non-existent photosensitizer.

Environmental problems may be encountered in obtaining a primary energy source. An example is the strip mining of coal. Nuclear safety and siting are two problems faced by nuclear energy sources. Offshore or seashore nuclear fueled plants are proposed for the dissipation of reject heat which otherwise might result in thermal pollution.

The use of hydrogen, either gas or liquid, as a primary fuel will necessitate the development of a large scale transmission and storage system. A hydrogen gas pipeline system similar to the existing natural gas pipeline system appears to be the most practical solution. The pipeline system must be capable of delivery of hydrogen gas directly from the generating plant to the user. It will be necessary to provide some storage capacity to meet both daily and seasonal peak shaving requirements. Daily needs may be economically satisfied by line pack storage. Seasonal peak shaving requirements may be satisfied most economically by large scale underground storage in depleted natural gas fields, aquifers, or other suitable natural formations. More costly peak shaving storage may also be accomplished by high pressure tanks, liquid hydrogen, and gas storage in mined caverns.

It is expected that a hydrogen pipeline system can be implemented using present day technology. Some research will be needed in order to establish specific design criteria for various portions of this system. Particular attention should be given to the question of hydrogen environment embrittlement of pipeline metals. It will also be necessary to establish the feasibility of converting portions of the existing natural gas pipeline to hydrogen. It appears that conversion of present pipelines can be accomplished with a moderate amount of problems.

The projected cost of hydrogen gas transmission is somewhat higher than natural gas transmission, but will be significantly less than overhead electrical transmission. It will be economical to transmit large quantities of energy through a hydrogen gas pipeline system. The cost of hydrogen generation will affect the overall economy of a hydrogen energy system more than the cost of transmission and storage of hydrogen gas.

The liquefaction of hydrogen is costly even though the required technology has been developed for some time. The ex-

pense arises from two facts: the process requires a great deal of energy and the process involves very complicated, and hence expensive, equipment. In addition, if storage of the liquid hydrogen is required, the storage tank cost must also be added to the cost of liquefaction.

As a result of these costs it is apparent that hydrogen will be transported and stored as a liquid only if there is no alternative. One such area of use may be the storage of energy for peak-shaving in a large power system where suitable gas storage facilities are not available.

If the hydrogen must be liquefied for some other purpose, such as peak-shaving, then the cryogenic properties of the liquid may be useful for other purposes. One potential use is the cooling of underground electrical cables to minimize the resistive power losses. Such cables could not compete with present overhead cables but they may have sufficient environmental and aesthetic advantages to be justified in the future.

Hydrides have some useful and advantageous properties when compared with gaseous and liquid hydrogen, particularly considering volume energy density. Also, even though the gas is stored at densities greater than liquid hydrogen, in hydride usage there are no associated liquefaction and cryogenic storage problems. However, even with the advantage of processing economics and handling safety over land liquid hydrogen storage, it appears that hydrides as fuel storers will be limited to small scale specific uses rather than large scale general uses. The reasons for this are the very poor mass energy densities and the probable costs of the metals. In addition, large scale storage would involve excessive amounts of the world production of many of the metals used to make hydrides.

It appears there are no technological or economical barriers to the transmission and storage of hydrogen either as gas or liquid in a hydrogen economy. Additional costs of safety, environmental and a social nature will probably be no greater than those involved with present natural gas transmission and storage systems.

The American energy system feels a need for abundant, ever-increasing quantities of low-cost energy. It was based on assumptions that domestic sources were virtually limitless. But the present energy shortage upsets beliefs and belies assumptions. The fundamental question now is, can we continue our present exponential rate of energy consumption? Clearly, the answer is no. In a finite world there are limits to growth. This does not imply that, as natural energy resources dwindle, we shall all freeze to death in the dark;

but it does mean that Americans must make two new assumptions; new energy sources must be found, and energy prices will be higher.

The current energy shortage is not simply a technological problem subject to technological solutions. It is also a safety, legal, economic, environmental, political and social problem. We have sought to analyze a switch to hydrogen energy in those terms.

Our major conclusions are:

- Hydrogen is environmentally a most desirable energy source; it is clean burning, transmissible and storable underground, and ecologically compatible because of its relatively short recycling time. Some present and proposed methods of production however, may be environmentally objectionable.
- Hydrogen fuel would be readily acceptable in the American energy system. A changeover would have some but minimal impact on social, legal, political and economic institutions.
- Hydrogen fuel's only potential drawback may be public fears about its image (the Hindenburg Syndrome/Hydrogen Bomb) and the fact that it is more dangerous than today's fuels. Public education and safety programs can change the image and insure the fact of a readily acceptable risk.

ORIGINAL PAGE IS
OF POOR QUALITY

CHAPTER 2

INTRODUCTION

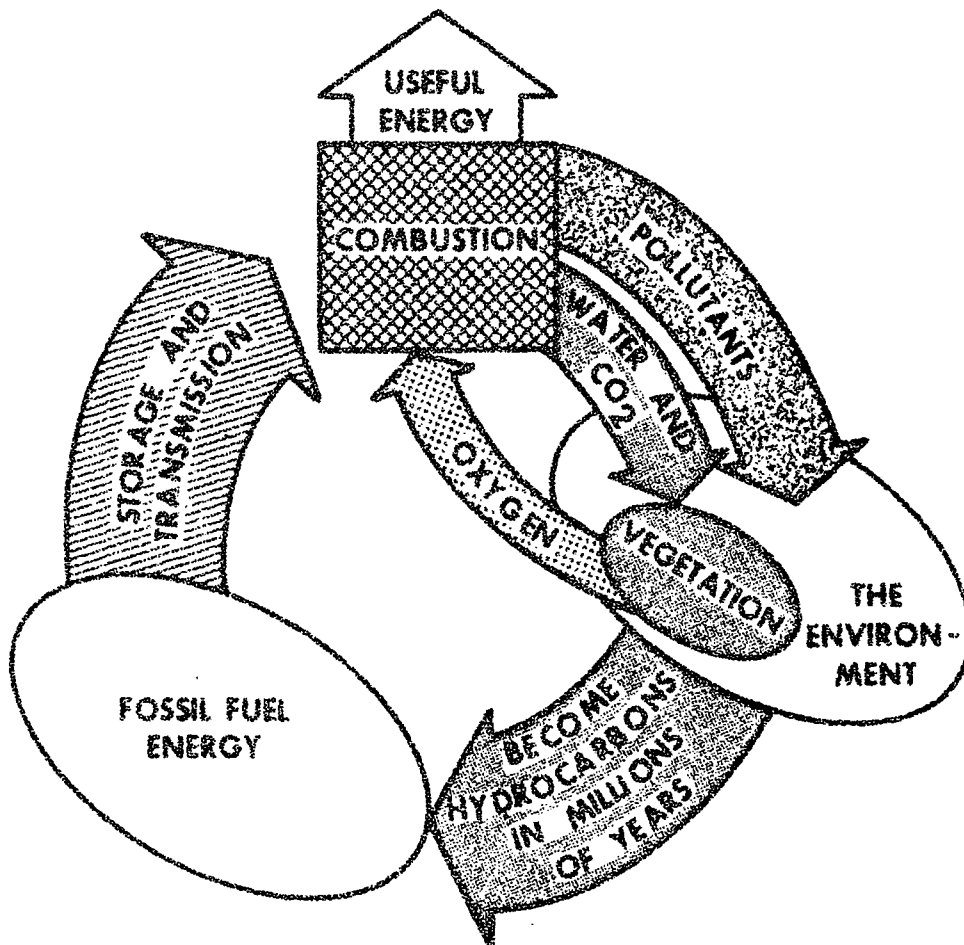

(ADAPTED FROM FORTUNE)

2.1 OVERALL ENERGY PICTURE

This work is related to the current energy shortage in the United States. Inadequate supplies of oil and gas, coal in the wrong form or restricted in use and delayed nuclear energy projects contribute to this shortage (2-1). Abundant energy is essential to the welfare of the United States, which is faced with a serious supply situation. A lasting shortage or even a temporarily interrupted supply will have a devastating impact upon the nation's economy, its standard of living, and its defense posture (2-2). These are large stakes which must be preserved by positive corrective actions.

It is this demonstrated need for energy which provides justification for this report - another report on hydrogen - an independent report on hydrogen as an energy carrier. Several reports have already been written about the hydrogen energy system or a hydrogen economy. A number of these are excellent examples of careful evaluations of the potential use of hydrogen in a specific industry (2-3 through 2-7).

The authors of this report were under no commitment or incentive (even to NASA) to present a particular point of view. They were assembled as Summer Faculty Fellows to do a systems analysis study. This report is the result of their work during the summer. Some positions or conclusions reported by other authors have been supported whereas other positions or conclusions have been critically questioned. This report may be utilized as an overview document by the decision makers who must deal with the energy problem.

2.2 THE FOSSIL FUEL CYCLE

The present energy shortage is the result of a combination of economic, environmental and political factors which are affecting the supply and use of fossil fuels as a source of energy. In the fossil fuel cycle (Figure 2-1), two factors are important. The first is the very long time cycle for the conversion of vegetation to fossil fuel. It takes millions of years and our present supply will be exhausted before more is formed. The second factor is the bad impact of the fossil fuel cycle on our environment (2-8).

Undesirable environmental effects occur at most points in the cycle. In the fossil fuel cycle, coal, oil or gas is burned at the point of use to produce heat energy which may be converted to useful mechanical energy or electrical energy. Air is used to supply the oxygen needed for combustion of the fuel and the products of combustion (carbon dioxide, carbon

monoxide, water, sulfur oxides, nitrogen oxides, hydrocarbon emissions and/or particulate matter) are returned to the atmosphere at the point of use. The undesirable materials become pollutants and, depending on the concentrations, may cause minor or major problems.

NASA-5-73-2430

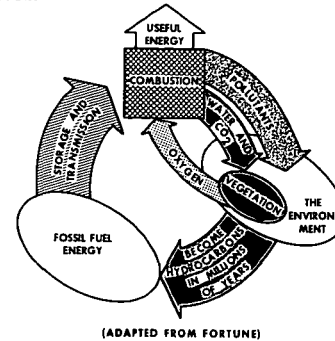

FIGURE 2-1
THE FOSSIL FUEL CYCLE

During production of coal, the surface of the land may be permanently scarred, vegetation may be disrupted and water drainage from surface or deep mines may pollute the streams or lakes. Certain health and safety consequences are undesirable aspects of coal mining. Oil and gas production may have lesser but nevertheless undesirable impacts on the local environment at the point of origin. In between production and use, the transportation of oil may result in oil spills and high voltage electric transmission lines may mar the landscape.

2.3 A HYDROGEN FUEL CYCLE

In the hydrogen fuel cycle (Figure 2-2), the main product of combustion, water, returns to the sea in a relatively short time. The conversion process may have some undesirable emissions, but their impact can be minimized by locating the conversion plant in a remote area. If air is used instead of oxygen for the combustion of hydrogen, some minor amounts of nitrogen oxides may be formed as pollutants, but even in this case the total pollution would be greatly reduced compared to that from fossil fuels.

Figure 2-2 illustrates a significant concept which must be emphasized. Hydrogen is not a primary source of energy. It can be produced from water only if one of the primary sources of energy - fossil, nuclear, or solar - is used in the process.

2.4 OUR ENERGY USE

ORIGINAL PAGE IS
OF POOR QUALITY

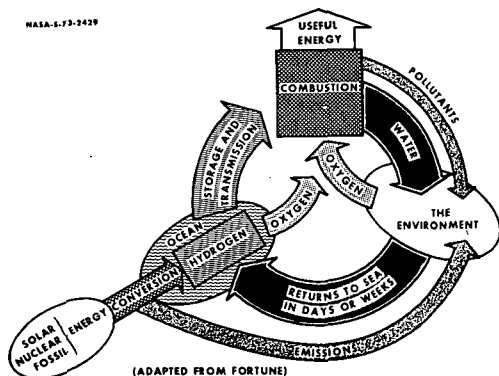

FIGURE 2-2
THE HYDROGEN FUEL CYCLE

The imbalance between supply and demand in the United States is a major factor in the energy shortage. The problem is further complicated by the complexity of our energy system, a study of which requires understanding of the

interplay among resources, reserves, production, distribution, pricing, demand, capital generation, and a host of other factors (2-1). The interplay of technological, environmental and political forces is one of the main concerns of this project.

The complexity of the energy system in the United States is forcefully illustrated in Figure 2-3 (2-4). In addition to demonstrating the interlocking relationships between sources of energy and end uses, this chart makes clear a factor not illustrated in Figure 2-1. A large portion of the energy is rejected heat which does no useful work, but is a result of the fundamental laws of thermodynamics.

The primary sources of energy in use today appear as petroleum and natural gas liquids, coal, natural gas, nuclear, hydroelectric and a small amount of geothermal. Each is used to some degree in the areas indicated:

- Electric power generation
- Residential and commercial

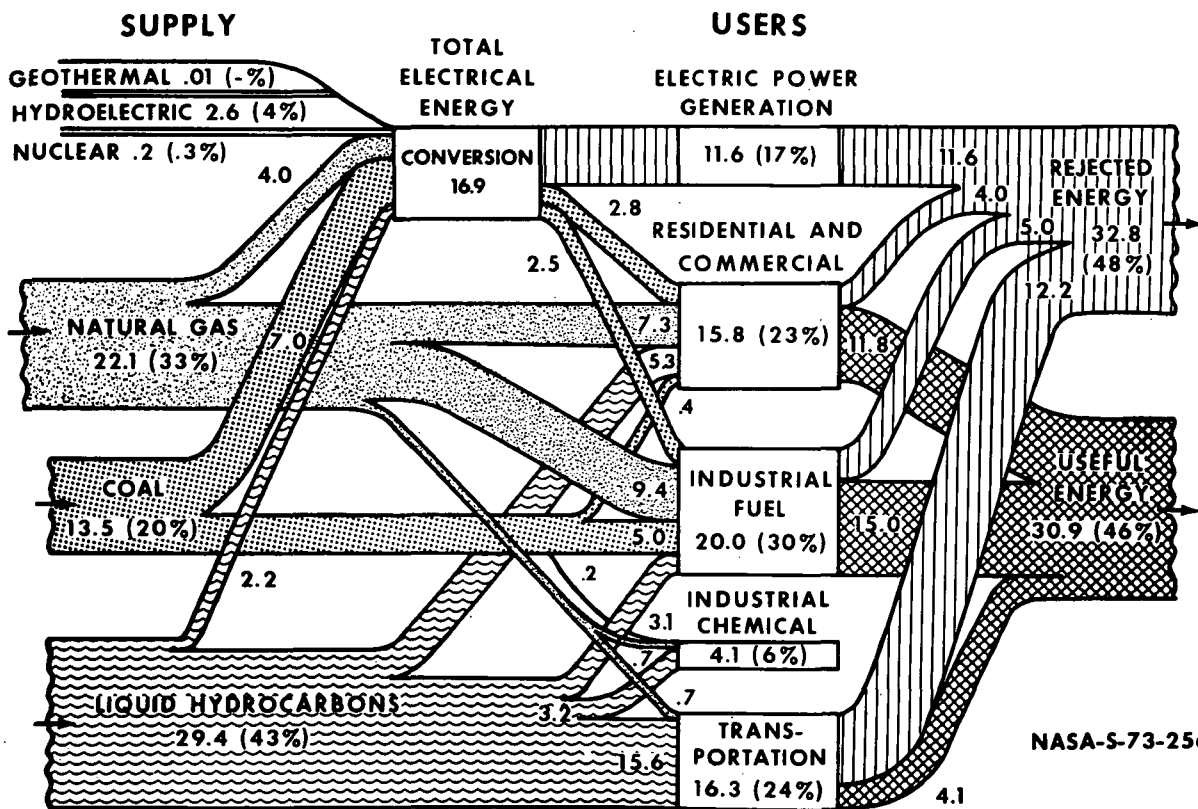

(ALL VALUES ARE $\times 10^{15}$ BTU - TOTAL U.S. DEMAND 67.8×10^{15} BTU)

FIGURE 2-3
UNITED STATES ENERGY FLOW PATTERNS IN 1970

ORIGINAL PAGE IS
OF POOR QUALITY

- Industrial fuel
- Industrial-chemical (nonenergy)
- Transportation

The United States uses extremely large quantities of energy each year. In 1970, a total of 67.8 quadrillion (67.8 Q) Btu were used. This country has developed many new processes and products not thought to be necessary by earlier citizens. As a result, energy demand has grown very rapidly as shown by the doubling time for energy use in the data below.

Year	Annual Use (10 ¹⁵ Btu)	Doubling Time (Years)
1910	17.0	--
1948	34.0	38
1970	68.0	22
2000 (est)	136.0	30

The amount of energy demand for these years has been estimated by many authors (2-2, 2-3 and 2-9 through 2-19). The most alarming forecasts are those based on exponential growth curves. One example is the results of a study which is published in the book The Limits to Growth (2-20). W. K. Davis (2-5) and others have indicated that historically all projections for energy and electricity have been wrong- and almost without exception, these estimates have been low. Even taking this admonition into consideration, our analysis for future demands for energy does not support the exponential growth projection. The forecasting of demand in this report does not follow any of the previously mentioned methods per se, rather it utilizes a method of saturation forecasting applicable to most areas of energy use. The saturation concept is used to place an upper limit on the future energy demand per capita. Applicable growth rates are used to project future demand, when the saturation limit is not appropriate. Conservation efforts are detailed to obtain what appear to be reasonable projections when factors of environment, scarcity of energy sources and costs are considered. The future demand pictures for total energy are presented in Figure 2-4 (saturation) and Figure 2-5 (conservation).

There is a certain amount of reluctance to project the future supply of energy. Some work has been done (2-4, 2-21); however, most forecasts terminate with 1985. For the purposes of this report, the projections of the National Petroleum Council (NPC) are used to project the future supply of energy (2-15). In particular, the optimistic case presented in Figure 2-4 is the Case I of NPC, and the conservative case of Figure 2-5 is Case IV of NPC. Projections beyond the

NPC's forecast to 1985 are not made here due to their questionable accuracy.

Unfortunately, none of the present domestic sources of primary energy (coal, oil, natural gas, nuclear energy and water power) is now adequate to meet either the nation's present needs or its future needs in our present mode of consumption of energy. For a period of time, the shortage is certain to become progressively greater.

NASA-9-73-2314

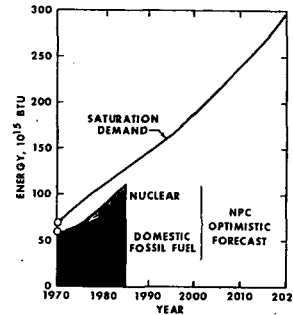

FIGURE 2-4
TOTAL SATURATION DEMAND BY AREA
1970-2020

NASA-9-73-2315

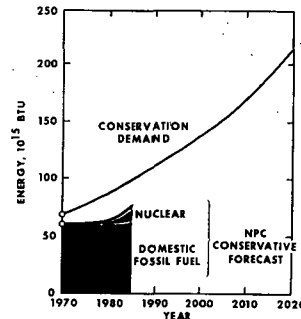

FIGURE 2-5
TOTAL CONSERVATION DEMAND BY AREA
1970-2020

Although there is plenty of raw energy around, it is not in a form convenient for immediate use, not located close enough to where it is needed (2-5), or not accessible within the current economic framework. A number of near term solutions such as increased geological exploration, secondary and tertiary extraction methods, and synthesis of fuels from coal may help. One impediment is the large amount of capital required to develop them to a degree necessary to meet demand (2-2). The above methods may be used only as interim steps until nuclear, fusion or other sources are

developed.

A number of consequences of a rapid development of domestic energy sources must be realized. Land use involved with mining operations and construction of a large number of plants present siting problems. Environmental restrictions will clash with the siting and operation of these facilities. The difficulties involved lead to the conclusion that not only is a direct attack on supply necessary, but that conservation efforts are equally necessary.

For the most part, sources of energy are used to perform work. But some are utilized for other important purposes. For example, most organic chemicals produced in the United States are derived from natural gas and petroleum. From these chemicals a wide and rapidly growing range of important products is produced; medicines, dyes, ammonia fertilizers, plastics, resins and a great number of others. Petroleum and coal products are also utilized extensively as a paving material for the nation's streets, roads, highways and parking lots. More than three-fourths of the nation's rubber supply is also derived from petroleum (2-2). This is not to say that petroleum should be restricted to the production of chemicals but rather it reveals that a shortage of petroleum will affect more than just the energy users. The development of our domestic sources of energy and the production of synthetic fuels such as hydrogen will be more expensive than energy derived from petroleum but there may be no other choice. It is of vital importance to the nation to develop some general-purpose fuel that can be produced from a variety of domestic energy sources.

2.5 WHY HYDROGEN?

Hydrogen fuel may be able to play an important part in the transition period from a fossil to a predominantly nuclear energy economy. Based on present and projected technology, nuclear energy will be restricted largely to the generation of electricity and very large-scale heat energy. There is little anticipated use for nuclear energy for surface transportation, residential and commercial uses other than in the form of electricity. Abundant supplies of hydrogen produced from fossil fuels, nuclear energy or ultimately from solar energy can provide the much needed flexibility and environmental acceptability needed in our economy.

Because of its importance as an industrial gas, much work has been done during the past fifty years on methods for producing and handling hydrogen. The early use of hydrogen to make ammonia, which was used to make fertilizers and munitions, firmly

established hydrogen as an important industrial gas for chemical and metallurgical uses. More recently, we have used large quantities of hydrogen as a high energy fuel for space travel. In these cases hydrogen has been produced primarily from fossil fuels because these were the lowest cost methods. With future limitations in the supply of fossil fuels becoming apparent and with the virtual certainty that the fossil fuels will cost more, other methods for making hydrogen are being investigated. An additional incentive to produce hydrogen in large quantities is the need for a clean burning fuel to help protect our environment.

There is a great temptation to recommend that a massive technological onslaught be mounted to solve the energy problem but this approach will not produce meaningful results in a short period of time, because the subject is relatively new and very complex. Moreover, there is no lack of embryo technological resources and technology is not the primary barrier to solving our energy problems. The primary barrier is the often-noted collision between energy and the environment, between energy and economics, and between energy and societal values (2-6). Hence, any proposed solution, such as the use of hydrogen fuel, should include these factors to evaluate the total societal impact of the proposal (Appendix B).

Analysis of social systems, however, is very complicated and must deal with factors which may be beyond our ability to systematically appraise and quantify. There are mechanisms by which we can obtain approximations and order of magnitude comparisons, but not fine detail.

Since these difficult problems could not be ignored, our analysis has used a modification of the paradigm suggested by David Easton for use in political analysis, but which is appropriate for macro-analysis of social systems (2-22). Also, we used an "Evaluation and Trade-off Matrix" to score and evaluate each subsystem under analysis. This matrix evaluation, which includes detailed environmental questions and conventional engineering factors, attempts an overall judgment of the social, political and legal impact of each subsystem (Appendix B, Figure B-2).

Because of anticipated changes in technology and other factors, estimates of energy supply and demand have been divided into three time periods, as follows:

- The present and near future to 1985
- The intermediate period from 1985 to 2000
- The long range future after 2000

Because 1985 may be a reasonable limit for projecting present trends and technology,

much attention has been focused on this future date. The overall energy problem may be better, or worse, or the same in 1985. However, there is little reason to predict that a significant improvement will occur before about 1990 and this would require prompt and vigorous action by all concerned.

With respect specifically to hydrogen as a fuel in the near future, it could serve as a clean fuel for special purposes. It has the versatility to serve both electrical and other thermal energy demands. It is compatible with a number of supply systems and it can be stored in large quantities either as a liquid or as a gas (2-7).

To discuss all aspects of the hydrogen fuel cycle, this report investigates the manner in which man would use it. Separate chapters discuss the production, storage and transportation, and the usage of hydrogen. Where possible, cost projections are included as part of the systems analysis. The safety of using hydrogen cannot be dismissed by stating that in the days of manufactured gas, which consisted of up to 50 percent hydrogen, people managed to live with the fire and explosion hazards of hydrogen. Hydrogen does form an easily ignitable explosive mixture with air, but there are compensating properties which tend to make it manageable. Hydrogen does have an adverse effect on materials of construction under certain conditions of time, temperature and pressure. These are described in detail in the report.

In the longer time frame, domestic sources of energy depend upon the use of renewable resources and the accompanying technologies of breeder reactors and fusion, with perhaps some contributions from solar and geothermal technologies. Bringing these into being in the next 25 years and within economic feasibility calls for private industrial initiative, heightened by judiciously applied federal incentives.

Before any possible conversion is made to a hydrogen economy there must be a ready market. This market does not exist today because hydrogen is more expensive than natural gas, gasoline, and other fuels (2-6). A proposed implementation method is obviously needed and is included as a section of the report.

2.6 OTHER WORK ON HYDROGEN

The results of this report and of other reports being written concurrently at two other NASA installations should provide guidance to those responsible for developing an energy policy for the nation. Our counterpart at NASA's Marshall Space Center is reporting on a systems analysis

of solar energy and the group at NASA's Langley Research Center is studying the overall energy picture with specific reference to fuels for aircraft.

SELECTED REFERENCES

- 2- 1 Krieger, J. H., "Energy: The Squeeze Begins", C & EN, pp 20-37, November 13, 1972.
- 2- 2 Winger, J. G., "Outlook for Energy in the United States to 1985", Chase Manhattan Bank, June, 1972.
- 2- 3 Lueck, D. W., "Energy and the Environment", General Electric TEMPO Report 72TMP-57, December, 1972.
- 2- 4 Austin, A. L., Rubin, B., Werth, G. C., "Energy: Uses, Sources, Issues", UCRL 51221, Lawrence Livermore Laboratory, May, 1972.
- 2- 5 Davis, W. K., "Environmental Challenges and Nuclear Fuels", Chem. Engr. Progress, V. 69, n. 6, pp 48-53, June, 1973.
- 2- 6 David, E. E., "Energy: A Strategy of Diversity", Technology Review, pp 26-31, June, 1973.
- 2- 7 Gregory, D. K., "The Hydrogen Economy", Scientific American, V. 22B, n. 1, pp 13-21, January, 1973.
- 2- 8 Lessing, L., "The Coming Hydrogen Economy", Fortune, pp 138-146, November, 1972.
- 2- 9 Morrison, W. E., "An Energy Model for the United States, Featuring Energy Balances for the Years 1947 to 1965 and Projections and Forecasts to the Years 1980 and 2000", Bureau of Mines, IC-8384, July, 1968.
- 2-10 Szego, G. C., "The U.S. Energy Problems", V. I, Summary Volume, NSF RANN 71-1-1, Intertechnology Corp., November, 1971.
- 2-11 Szego, G. C., "The U.S. Energy Problems", V. II, Appendices Volume, NSF RANN 71-1-2, Intertechnology Corp., November, 1971.
- 2-12 Hirst, E., "Energy Consumption for Transportation in the U.S", ORNL-NSF-EP-15, Oak Ridge National Lab, March, 1972.
- 2-13 Briefings Before the Task Force on Energy, Committee on Science and Astronautics of House of Representatives, August, 1972.
- 2-14 Kelly, R., Reynolds, R. A., "Energy Supply and Demand Political Implica-

- tions", General Electric TEMPO Report 72TMP-51, December, 1972.
- 2-15 "U.S. Energy Outlook: A Summary Report of the National Petroleum Council", National Petroleum Council, December, 1972.
- 2-16 Morris, D. N., "Future Energy Demand and its Effect on the Environment", Rand, R-1098-NSF, September, 1972.
- 2-17 "The National Energy Outlook", Shell Oil Publication, March, 1973.
- 2-18 McKetta, J. J., "Today's Energy Sources - Their Projected Life", Paper presented at Symposium for Industrial Users of Natural Gas, April, 1973.
- 2-19 Hirst, E., "Energy Intensiveness of Passenger and Freight Transport Modes: 1950 to 1970", ORNL-NSF-EP-44, April, 1973.
- 2-20 Meadows, D. H., Meadows, D. L., The Limits to Growth. New American Library, 1972.
- 2-21 "A Review and Comparison of Selected United States Energy Forecasts", Battelle Memorial Institute, December, 1969.
- 2-22 David Easton, A Systems Analysis of Political Life, New York; John Wiley, 1965, Chapter 2.

N74-11731

ORIGINAL PAGE IS
OF POOR QUALITY

CHAPTER 3

PRODUCTION OF HYDROGEN

3

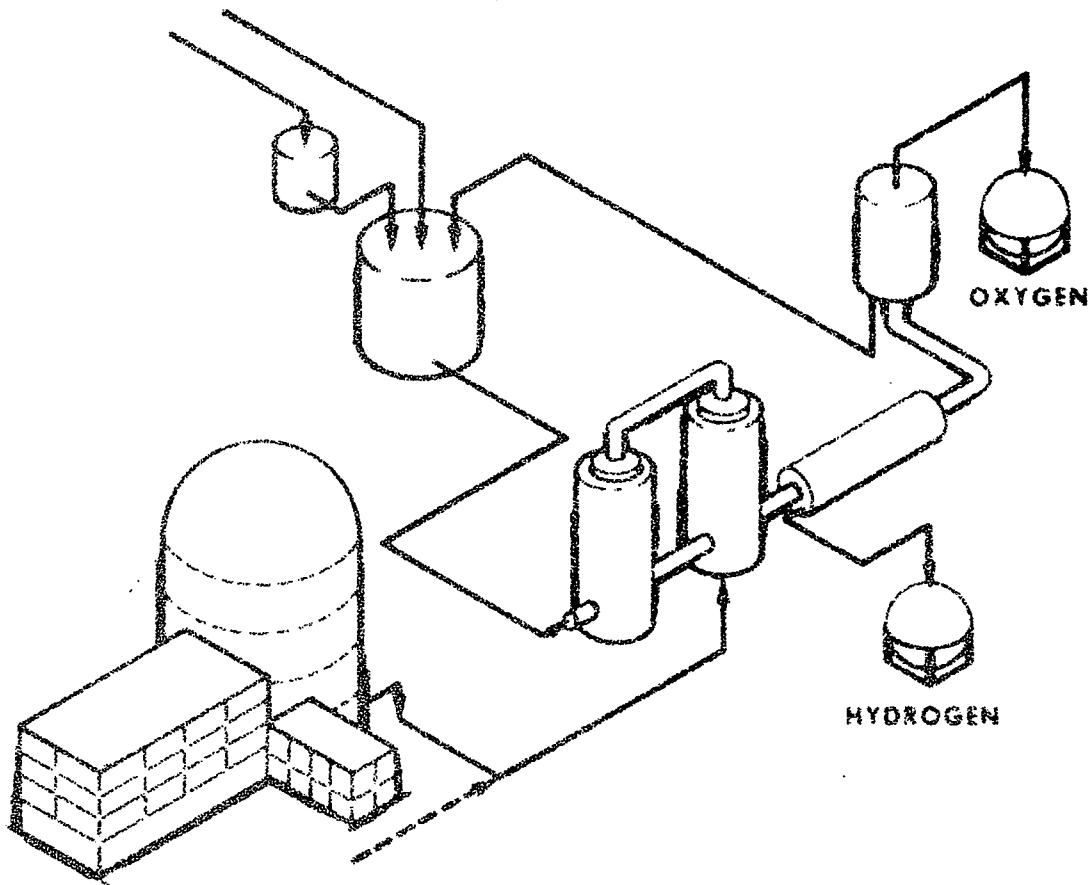

3.1 INTRODUCTION

Hydrogen is a most promising future medium for energy transmission and storage. It may be extracted from fossil fuels, from water or both simultaneously. While fossil fuel supplies are diminishing and must be regarded as a limited resource, water may be considered inexhaustible.

In addition to the raw material sources consumed in hydrogen production, energy sources must be used to extract hydrogen from fossil supplies or from water. This energy can be obtained directly from fossil fuels but primary energy sources including nuclear, solar, wind, fossil, geothermal, or ocean temperature gradients must be used to obtain hydrogen from water.

The use of nuclear energy as a primary energy source has already proven to be economically attractive in electricity production, principally due to the relatively low cost of nuclear fuel. Therefore, development of the other energy resources, notably solar, wind, and geothermal, is not likely to displace nuclear energy in the short-term as a primary energy source.

Hydrogen is produced today in large quantities as a major chemical intermediate for use in the chemical process industries. Presently hydrogen production in the United States is about 3×10^{12} scf per year. The major proportion of this intermediate is presently made from fossil fuel (natural gas or naphtha) by either steam reforming or partial oxidation processes.

If hydrogen is envisioned as a fuel, much larger amounts will be needed. In these cases, it is obvious that the primary raw material source for hydrogen must be water. Water can be split into its elements, hydrogen and oxygen, by a variety of processes. A commercially available process for producing hydrogen is the electrolysis of water. This process is practiced in areas of the world such as Canada, Norway and India where there is either an abundant supply of cheap hydroelectric power or no natural gas source. The main drawback to this method is that electricity must first be generated and then used; consequently, the generation cost of electrolytic hydrogen must always be more than that of electricity.

A more promising method of hydrogen production currently under consideration is a closed cycle thermochemical process for which energy to obtain the hydrogen from water is in the form of heat rather than work. These cycles (many different types of process have been proposed) operate at maximum temperatures in the neighborhood of 1000°K with theoretical thermal efficiencies in the range of 20 to 50 percent. As yet, none of these cycles have been experimentally proven in their entirety; however, much research and development work is currently being done.

Since coal reserves represent a large fraction of our domestic fossil energy reserves, but are currently underutilized, this primary energy source may be used as a short and mid term source of energy. Even though coal resources could contribute a significant portion of the energy needs for at least a century, several important factors (developing technology, land reclamation, mine safety, possible water shortage, and shortage of personnel) could delay its large scale implementation until the late 1980's. It is doubtful that coal will be used to produce hydrogen on a large scale for the hydrogen economy, because of factors favoring methane production. The photolytic decomposition of water, the direct thermal dissociation of water, and the production of hydrogen from organic waste by algae are not considered feasible in the near future because of low efficiency, high cost, or undeveloped technology.

The following discussion section will describe in greater detail our approach to analyzing methods of producing hydrogen for a hydrogen economy.

3.2 DISCUSSION OF METHODOLOGY

If hydrogen is to become a widely used energy carrier, it must be produced economically and efficiently on a large scale for a long time period. Therefore hydrogen production must be linked to those primary energy sources which are currently available, as well as to those which might be available in the future. Figure 3-1 presents a summary of hydrogen production methods from a number of primary energy sources. There may be some primary energy sources and/or process paths which are not shown, but the chart does indicate the interrelationships between many possible sources of primary energy and the production of hydrogen fuel.

This chart shows that hydrogen can be produced by current primary energy sources (e.g. gas, oil, coal, fission) as well as by those energy sources which might be available in the future (e.g. solar, fusion, geothermal). Two important routes couple the several primary sources to hydrogen, thermochemical decomposition and electrolysis. Several primary sources could utilize either path (e.g. nuclear or solar), while other sources only seem practical when coupled to one of these paths (e.g. wind-electrolysis, geothermal-electrolysis).

An important characteristic of the future energy supply of the United States is that it will probably be based upon many primary sources. This trend is the result of the heavy demand on the limited domestic energy supplies. Economic and environmental constraints may cause energy to be extracted from many sources so that costs can be held

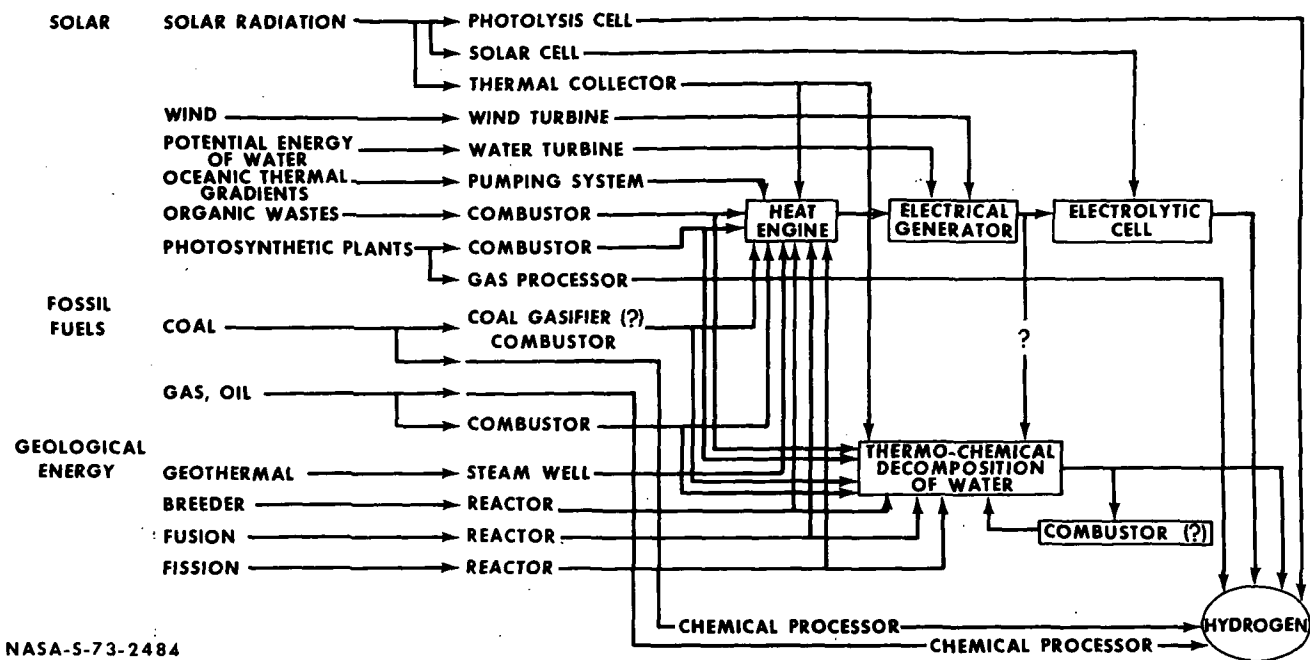

NASA-5-73-2484

FIGURE 3-1
SUMMARY OF METHODS FOR HYDROGEN PRODUCTION

down and the resulting pollutants (including reject heat) can be disposed of in many reservoirs.

The remainder of this chapter will show the ways in which primary energy can be converted into hydrogen so that these economic and environmental costs can be minimized. Those production paths which are particularly promising and/or which are technologically developed are analyzed in considerable detail, while those which are less promising and/or technologically undeveloped are considered briefly or not at all.

The following two sections will analyze sources and processes for the production of hydrogen. The sources section will include an evaluation of the natural resource which serves as the energy input to the system (e.g. coal, solar radiation, wind, uranium), as well as a discussion of the initial device which transforms this raw material into a useable energy form (e.g. coal mine, solar collection, wind turbine, reactor). The processes section will then show how this useable energy can be stored in hydrogen. For some production schemes, the initial conversion device can also serve as the process device to produce hydrogen (e.g. photolysis cell).

Section 3.5 considers combinations of primary energy sources and processes by which hydrogen may be produced. These combinations are depicted as paths on Figure 3-1.

Finally, the most promising paths are examined in more detail in Section 3.6.

3.3 PRIMARY ENERGY SOURCES

3.3.1 SOLAR ENERGY

The advantages of solar energy are well recognized. It is an available, non-depletable and nonpolluting energy source (3-1). Two major problems arise in an attempt to utilize this source. The first is caused by the low power density (or low flux) of sunshine, and the second is due to the intermittent nature of sunlight, i.e., there is no direct sunlight at night or on cloudy days. The cost of utilizing solar energy is largely the cost of overcoming these two problems, which, until now, have prevented widespread solar energy use.

The amount of solar energy arriving at the outer edge of the earth's atmosphere is 2.0 calories per square centimeter minimum or 1,390 watts per square meter (W/m^2) (3-2). Some of this is intercepted by the earth's atmosphere, and the amount of solar energy that finally impinges on the earth's surface depends upon the latitude, time of day, season of the year, and local weather conditions. These effects are illustrated in Figure 3-2. The top curve shows the solar radiation impinging on the desert floor near Yuma,

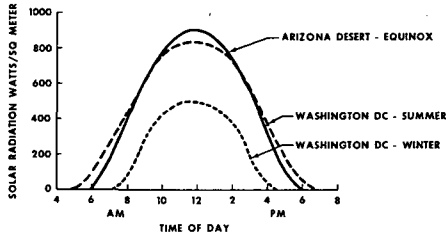

FIGURE 3-2
SOLAR ENERGY DENSITY AT TWO
LOCATIONS FOR THREE SEASONS

Arizona, at the equinox (3-3). At noon, the energy flux is 920 W/m^2 , with the average being 700 W/m^2 during the 12 hours of daylight. During the other 12 hours, the solar radiation is zero.

Some feeling for the effect of latitude and season can be obtained by considering conditions in Washington, D. C. On a clear summer day, the average intensity of the solar radiation striking the earth's surface during the 14 daylight hours is 478 W/m^2 (3-4). During the winter, this value drops to an average of 248 W/m^2 for 9.5 hours of daylight. The amount of energy impinging on one square meter in one day is the area under the curve in Figure 3-2. For the upper curve this quantity is 8.4 kilowatt hours (kWh), while the lower curve yields 2.36 kWh. The effects of geographic location and season are seen to be quite significant. All solar energy calculations used in this report are based on the upper curve of Figure 3-2.

Consider now the power generating capacity of the solar energy falling on a one square mile area. Both Meinel (3-5) and Ralph (3-6) have concluded that one square mile of radiation will produce electrical power at the average rate of about 67,000 kW, assuming that the overall efficiency for converting solar energy to electrical energy is 10 percent. In a similar calculation based on solar radiation in the Central Asian Soviet Socialist Republics, Vermishev (3-7) concluded that the solar energy collected over 1000 square kilometers (360 square miles) would generate about 200,000 MW. This represents the entire generating capacity of the USSR in 1964. Vermishev assumed an overall efficiency of 20 percent. However, Meinel (3-8) estimates that our electrical needs in the year 2000 will be about 1,000,000 MW. Which could be produced by solar energy falling on an area having dimensions of 75 miles by 75 miles, located in the Arizona desert. These values indicate the problem caused by the low flux of solar

energy. Large areas must be covered with solar collectors if significant quantities of solar energy are to be obtained.

The technical problems involved with solar energy collection are substantial. Although the energy is free, the cost of collecting it is high. As a result, the use of solar energy is a capital intensive enterprise. The cost of the energy depends largely on the capital costs of the very large area of solar collectors required. By contrast, in the electric power industry, the cost of fuel is a significant fraction of the cost of electric power, but the capital investment is comparatively lower.

Solar energy is an intermittent energy source. Its intensity depends upon the time of day, season of the year, latitude of the solar collector, and local weather conditions, as shown in Figure 3-2. The variations in power demand do not correspond to the variations in the solar energy supply. If solar energy is to be used during a 24 hour day, it is apparent that energy must be stored during the daylight hours and released at night. Energy must also be stored during sunny days for use during cloudy days. The problem has been considered for many years and a number of solutions have been proposed. Lof (3-8) has used beds of gravel to store heat during the day and release it at night to heat a home. In the late 1940's, Telkes (3-9) suggested using the heat of fusion of various salts as an energy storage method, and this method is still discussed, but in a higher temperature range. Baranov (3-10), for example, suggests using the heat of fusion of metallic oxides for high temperature storage of solar energy, while Meinel (3-11) suggests using the heat of fusion of salt eutectics for energy storage at temperatures near 550°C .

Recently, various researchers have briefly suggested that energy can be stored by using solar energy to produce hydrogen. The hydrogen would then be transported or stored and burned as energy is needed. Hydrogen production assists in the energy storage and distribution problems since both are feasible (see chapter 4).

3.3.2 WIND ENERGY

The energy of the winds is a form of solar energy. It is a renewable source of power. In the past, the exploitation of wind power was either in geographically special locations (farms on the plains and offshore oil platforms) or in the developing, often rural, nations. It was felt that wind power had no place in an industrialized, urban country like the United States. However, as other more conventional forms of primary energy become increasingly unobtainable or undesirable, the advantages of all forms of solar energy, including wind power, become apparent.

The environmental advantages of wind power are significant. Rather than being a dirty source, wind power is inherently clean. There is no fuel to be consumed and no resulting air, water, or thermal pollution. The energy which is extracted from the wind would otherwise appear in the atmosphere as thermal energy generated by viscous dissipation. A wind power system takes energy from the atmosphere at the wind turbine and delivers this energy at the point of use. Because the energy involved in the transfer is a small fraction of the total natural energy flow of the atmosphere, and because of the rapid mixing of the atmosphere, there are virtually no environmental effects.

The limitations on the exploitation of wind energy are economic. The diffused nature of wind energy requires that the wind turbines may need to be located at sites which are remote from the load center. The variable nature of wind energy requires that some fraction of extracted energy be stored so that the energy demand pattern can be matched. Because hydrogen appears to be an economical form in which to store and transmit energy, the combination of the two technologies - primary wind power and transfer of energy utilizing hydrogen - may result in a practical contribution to the total energy economy.

The technology of wind turbines is well established. Extensive research and prototype development were conducted in the 1940's and 1950's, in both the United States and Europe (3-12, 3-13). Most of this work

was set aside because of the promise of low-cost nuclear energy. Current developments tend to make wind power more practical. The production of hydrogen from wind power allows the wind capacity to be counted toward the base capacity. The size of the conventional base load plants can therefore be reduced. At the same time, rising fuel costs (both nuclear and fossil) make operating cost of conventional units more expensive. Wind Power cost (for a particular installation) is constant. In addition, environmental impact and social costs of nuclear and fossil power tend to be proportional to total output. Thus any energy derived from the wind which reduces the output of conventional plants reduces the amount of these external costs of energy. These factors will serve to lower the cost of wind power, relative to fossil and nuclear power, in the future.

There is a trade-off between the total amount of wind energy available and the cost of energy produced. As less favorable sites are exploited, each new site will be less productive (assuming a constant wind turbine technology). Thus, the amount of wind energy available has economic limitations. Table 3-1 (3-14) presents one proposal for the development of 1.536×10^{12} kWh per year of electrical energy by wind power for the year 2000. The hydrogen produced by these selected, favorable sites would represent 5 to 10 percent of the projected total energy demand of the year 2000.

Although wind power will probably not be able to economically supply a majority of the future energy needs, it can provide

TABLE 3-1
MAXIMUM ELECTRICAL ENERGY PRODUCTION FROM WIND POWER

Site	Annual power production	Maximum possible by year
Offshore, New England	159 X 10 ⁹ kWh	1990
Offshore, New England	318 X 10 ⁹ kWh	2000
Offshore, Eastern Seaboard, along the 100 meter contour, Ambrose shipping channel south to Charleston, S.C.	283 X 10 ⁹ kWh	2000
Along the E-W Axis, Lake Superior (320m)	35 X 10 ⁹ kWh	2000
Along the N-S Axis, Lake Michigan (220m)	29 X 10 ⁹ kWh	2000
Along the N-S Axis, Lake Huron (160m)	23 X 10 ⁹ kWh	2000
Along the W-E Axis, Lake Erie (200m)	23 X 10 ⁹ kWh	2000
Along the W-E Axis, Lake Ontario (160m)	23 X 10 ⁹ kWh	2000
Through the Great Plains from Dallas, Texas North in a path 300 miles wide W-E, and 1300 miles long, S to N. Wind Stations to be clustered in groups of 165, at least 60 miles between groups (sparse coverage)	210 X 10 ⁹ kWh	2000

TABLE 3-1 (Continued)
MAXIMUM ELECTRICAL ENERGY PRODUCTION FROM WIND POWER

Site	Annual power production	Maximum possible by year
Offshore the Texas Gulf Coast, along a length of 400 miles from the Mexican border, eastward, along the 100 meter contour	190 X 10 ⁹ kWh	2000
Along the Aleutian Chain, 1260 miles, on transects each 35 miles long, spaced at 60-mile intervals, between 100 meter contours. Hydrogen is to be liquefied and transported to California by tanker.	402 X 10 ⁹ kWh	2000
Estimated Total Production Possible: 1.536 X 10 ¹² kWh by year 2000		

NOTE: This electrical output was produced from fuel cells which were assumed to be 51 percent efficient. Thus the energy of the hydrogen produced is 3 X 10¹² kWh per year.

a small and environmentally desirable contribution. At a recent National Science Foundation sponsored conference on solar energy, it was recommended that wind power development be included in future expanded programs to exploit solar energy.

in which carbon atoms, bound in the fuel, are irreversibly converted to carbon dioxide with the liberation of energy. Ultimately such fuel will be totally depleted. As the limit of such a resource is approached, a prudent society will conserve the resource while developing alternative primary sources.

3.3.3 FOSSIL ENERGY

Fossil fuels (natural gas; petroleum, coal, shale oil, tar sands) are non-renewable sources of primary energy, because the rate of their consumption is orders of magnitude greater than their natural rates of formation. The result is an open cycle

Table 3-2 gives the estimated domestic energy reserves of fossil fuels in terms of quadrillion (10¹⁵) Btu or Q's. The second column gives resources identified and recoverable using today's technology. The total represents the ultimate amount estimated to be available. The accuracy of these estimates probably ranges from 20 to 50 percent for identified-recoverable

TABLE 3-2
ESTIMATED DOMESTIC FOSSIL FUEL RESERVES

Resource	Identified and Recoverable, Q	Total Q	Date of Estimate
Natural Gas	299 ^a	6,810	1970
Petroleum	302 ^b	16,800	1970
Coal	5,200-10,100 ^c	83,200	1972
Oil Shale	928- 3,480 ^a	151,000	1972
^a 1,032 Btu/scf, ^b 5,800,000 Btu/bbl, ^c 26,000,000 Btu/ton			

resources and may be an order of magnitude in error for the total resource available (3-15). Of the estimates available for natural gas and petroleum, the estimate presented here is the highest because it includes the largest proportion of favorable ground for exploration. Tar sands are excluded because they represent a small fraction of available domestic resources (they are being developed in Canada for the United States energy market). Several observations may be made from this table. Ultimate oil shale reserves may amount to more than all others combined, but identified and recoverable reserves of oil shale are less than those for coal. Another important factor, in the favor of coal, is that its geographic distribution is more uniform than for oil shale. Compare with these quantities the total energy consumption of about 69 Q by the United States in 1971. By 1980 this is expected to increase to at least 96 Q, and by 1990 to 140 Q per year (3-16).

Another estimate of fossil energy resources and uses is given in Figure 3-3 (3-17), where it may be seen that, even though coal may account for some 80 percent of natural energy resources available today, it is currently being used to supply only about 18 percent of the total domestic energy consumption, primarily in the generation of electrical energy.

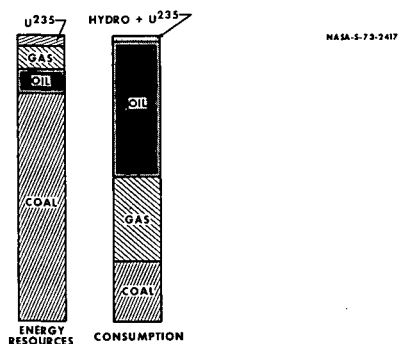

FIGURE 3-3
COAL RESOURCES AND UTILIZATION

If we are to maintain a highly reliable domestic energy resource, it is clear that coal usage must be expanded considerably. Recognizing this, President Nixon, in his energy message of April 18, 1973, urged that "highest national priority be given to expanded development and utilization of our coal reserves". Remarks, in a later section on the utilization of fossil energy in a hydrogen economy will be solely devoted to coal. This choice is justified on the basis that known domestic reserves of petroleum and gas are insufficient for this contingency, that imported feedstocks are detrimental

to national security, that new domestic discoveries of petroleum and gas will only prolong the inevitable shift to coal (or shale oil), and that shale oil technology and problems are similar to those of coal.

3.3.4 NUCLEAR ENERGY

Nuclear energy will play an important role in fulfilling society's future energy requirements. Long term forecasts indicate that a growing proportion of this energy will be supplied by fission reactors and, in the distant future, perhaps by thermonuclear fusion. Because energy from controlled thermonuclear fusion has not yet proven to be feasible (3-18), it is assumed that the primary energy will be obtained from nuclear fission,

At present, the United States has available both light water reactors (LWR) and high temperature gas-cooled reactors (HTGR). The major emphasis on reactor development has been on water-cooled reactors using the slow neutron induced fission of U^{235} (3-19). The LWR may be classified in either of two categories, the pressurized water reactor (PWR) or the boiling water reactor (BWR). The PWR has a low operating temperature in the range of 530 to 630°K, but operating pressures up to 2500 psi are necessary to prevent boiling. Heat is usually transferred through a heat exchanger to generate steam for electrical generation. The BWR power reactor allows water to boil, producing saturated steam at about the same temperature as the PWR and 1000 psi.

In contrast, the high temperature gas-cooled reactor (HTGR) is cooled by helium gas and provides a potential supply of high temperature heat in the range 1000 to 1100°K. The hot helium gas is used to generate steam at temperatures and pressures typically used in modern steam turbine-electrical generation plants. The fuel cycle is based on thorium conversion to U^{233} with U^{235} as the start-up material.

Presently, a variety of breeder reactors is being developed. The main reactor types include the liquid-metal cooled fast breeder reactor (LMFBR), the gas-cooled fast breeder reactor (GCFBR), and in Germany, the pebble-bed breeder reactor (PBBR). The LMFBR converts U^{238} to Pu^{239} , thereby using up nearly all of the energy potential of uranium supplied by nature in the more abundant (99 percent) U^{238} form. The GCFBR is also a plutonium breeder reactor. The German PBBR is still in the research stage with work being done to develop a ceramic pebble fuel.

Current fissionable uranium resources identified and recoverable with today's technology and costs are of the same order as oil and gas (see Figure 3-3). Because of the slowdown in development of nuclear installations, there is little incentive

for further exploration. Even if the fast breeder reactor technology were implemented to reduce the requirements on existing enrichment plant capacity, by 1985 the enrichment capability will be the limiting factor in the growth of the nuclear industry. The problem of waste disposal for breeder reactors is currently under investigation.

Table 3-3 summarizes the important characteristics for the nuclear reactor types available in the near future.

3.3.5 MISCELLANEOUS

As traditional energy supplies become more limited, increased attention is being devoted to "unconventional" sources of energy. This section will briefly review

some of these other primary sources of energy, especially as they might fit into a hydrogen fuel system.

A common characteristic of such energy sources is the difficulty in estimating economic costs and in predicting total amounts of energy available. The report of the NSF/NASA Solar Energy Panel (3-14) presents such an analysis for energy from solar sources. Table 3-4 gives a summary of their conclusions. It is presented here to serve as an example of the kind of analysis that is useful in evaluating the relative merits of these proposed energy sources. It also gives an indication of the magnitude of energy which might be supplied by such unconventional energy sources.

TABLE 3-3
NUCLEAR REACTOR COMPARISON

Reactor	Operating Temperature (°K)	Efficiency, Thermal to Electrical	Installed Capital Cost (\$/ kW elec) 1972 \$		Date Available
			(Ref. 3-21)	(Ref. 3-19, 3-20)	
Light Water Reactor	600	0.33	220	300	Now
High Temperature Gas-Cooled Reactor	1150	0.40	220	300	Now
Liquid metal Fast Breeder Reactor	800	0.40	250	350	1980's
Gas-Cooled Fast Breeder Reactor	800	0.40	220	300	1980's

TABLE 3-4
IMPACT OF SOLAR ENERGY APPLICATIONS ON THE REFERENCE ENERGY SYSTEM ⁽¹⁾

System	Year	Annual consumption ⁽²⁾ (10 ¹⁵ Btu)	Percent of total energy consumption in USA	Estimated percent of market captured	\$10 ⁶ Annual savings in fossil fuel @ \$1.00/10 ⁶ Btu	Significance ⁽⁶⁾ of impact on reference energy system by 2020
Thermal energy for buildings	1985	(3) 17	15	<1		Major on building industry
	2000	(3) 21	12	10	2,100	Minor on total energy consumption
	2020	(3) 30	10	35	10,500	
Conversion of organic materials to fuels or energy	1985	37	32			Major on electric utility
	2000	76	43	1	760	Modest on total energy consumption
	2020	160	53	10	16,000	

TABLE 3-4 (Continued)
 IMPACT OF SOLAR ENERGY APPLICATIONS ON THE REFERENCE ENERGY SYSTEM⁽¹⁾

System	Year	Annual consumption ⁽²⁾ (10 ¹⁵ Btu)	Percent of total energy consumption in USA	Estimated percent of market captured	\$10 ⁶ Annual savings in fossil fuel @ \$1.00/10 ⁶ Btu	Significance ⁽⁶⁾ of impact on reference energy system by 2020
Bioconversion to methane	1985	(4) 27	23	1	270	Major on gas consumption
	2000	(4) 31	18	10	3,100	Minor on total energy consumption
	2020	(4) 41	14	30	12,300	
Pyrolysis to liquid fuel fuels	1985	(5) 50	44			Major on oil consumption
	2000	(5) 63	36	1	630	Minor on total energy consumption
	2020	(5) 80	27	10	8,000	
Chemical reduction to liquid fuels	1985	(5) 50	43			Major on oil consumption
	2000	(5) 63	36	1	630	Minor on total energy consumption
	2020	(5) 80	27	10	8,000	
Electric power generation Thermal conversion	1985	37	32			Modest on electric utility industry
	2000	76	43	1	760	Modest on total energy consumption
	2020	160	52	5	8,000	
Photovoltaic Systems on buildings	1985	(3) 9	9			Major on building industry
	2000	(3) 15	9	5	750	Minor on total energy consumption
	2020	(3) 21	6	50	10,500	
Ground stations	1985	37	32			Major on electric utility industry
	2000	76	43	1		Modest on total energy consumption
	2020	160	52	10	16,000	
Space stations	1985	37	32			Major on electric utility industry
	2000	76	43	1	760	Modest on total energy consumption
	2020	160	52	10	16,000	
Wind energy conversion	1985	37	32			Major on electric utility industry
	2000	76	43	1	760	Modest on total energy consumption
	2020	160	52	10	16,000	
Ocean thermal difference	1985	37	32			Major on electric utility industry
	2000	76	43	1	760	Modest on total energy consumption
	2020	160	52	10	16,000	

- NOTES: (1) Each of the above impact estimates assumes the successful development of practical economically competitive systems. However in each case a judgment has been made resulting in estimates that are less than the maximum possible. The estimates are not necessarily additive since not all systems will be carried to commercial readiness
- (2) Nonrenewable fuel consumed to generate the electric power as projected in the energy reference systems and resource data report, AET 8. Associated Universities, Inc. April 1972 [1]
- (3) Nonrenewable fuel consumed to generate the projected electric power requirements for buildings, AET 8 [1].
- (4) Methane consumed to meet projected energy needs, AET 8 [1].
- (5) Oil consumed to meet projected energy needs, AET 8 [1].
- (6) Minor, 0.5%, Modest, 5-10%, Major, 10%.

Rather than thoroughly analyze every possible miscellaneous source of energy, three of these, oceanic thermal gradients, geothermal, and bioconversion of organic wastes, will serve as examples of the ways in which a hydrogen energy system can be tied to the exploitation of multiple, unconventional energy sources.

3.3.5.1 OCEANIC THERMAL GRADIENTS

A common problem in exploiting solar energy is that it is a very diffuse form of energy. One proposed way to make its use more feasible is to take energy from sites where nature has already concentrated it. One such proposal is to use the thermal gradients of the ocean to drive a heat engine.

The most promising location near the United States for the exploitation of oceanic thermal gradients is off the Florida and Georgia coast in the Gulf Stream. In this region, cold water (5° C) from the melting polar caps flows under a region of less dense water which has been heated (25° C) by the tropical sun. The temperature gradient occurs over a depth of 1000 to 3000 feet.

Anderson and Anderson (3-22) calculated that the energy content of the flow of warm Gulf Stream water is sufficient to generate 182×10^{12} kWh of electricity per year. This is almost 75 times the projected 1980 domestic demand. The recent NSF/NASA Solar Energy Panel (3-14), following suggested designs by Heronemus (3-23), concluded that oceanic thermal gradients could supply at least 10 percent of the projected electrical demand by 2020.

Although two demonstration oceanic thermal power units have been built (Cuba in 1929 and Ivory Coast in 1956), economic estimates on the cost of large scale units are speculative at this time. The preliminary estimate by Heronemus of \$200 to \$400 per kWh makes this method look promising.

If the energy content off the Florida-Georgia coast were developed on a large scale, this energy would have to be transmitted in large quantities and over long distances throughout the country. Conversion of this energy into hydrogen is attractive, since hydrogen can be transmitted economically. Because of the relatively low temperature source available from oceanic thermal gradients, it appears that the only practical way to produce hydrogen from this source of energy is through the heat engine-electrical-electrolysis path. The temperature difference would be used to drive a heat engine (probably Rankine cycle) and an electric generator.

The technical problems associated with exploitation of oceanic thermal gradients center around the complexities of handling very large volumes of sea water. Heat exchangers need to be large, efficient, and resistant to corrosion by sea water. Further studies are needed to determine the optimum working fluid of the heat engine (3-24). Oceanic thermal energy appears to be very attractive environmentally (3-25). By re-injecting discharge water at a depth corresponding to its temperature, thermal effects are minimized. If the plant is submerged, it poses minimal aesthetic degradation, reduces safety problems to shipping, and is not susceptible to damage by storms.

The NSF/NASA Solar Energy Panel recommends a 15 year research and development program leading to the development of a 400 MW demonstration plant. Renewable power from oceanic thermal gradients, if technically developed, offers many benefits. The advantages of a hydrogen energy system complement the development of power from oceanic thermal gradients.

3.3.5.2 GEOTHERMAL POWER

Geothermal sources of energy can be classified into three types; dry steam, hot water, and hot rock. These are listed in order of increasing size of reserves. This

is also the order of increasing technical complexity.

Dry steam wells are currently producing 298 MW of electrical power at the Geysers site near San Francisco. This site and similar ones in Nevada might be able to supply up to 7000 MW by 1985 (3-26). The technology to exploit such dry steam wells is developed.

Hot water (brine) resources are estimated to be 20 times as large as dry steam resources, although the technology for this exploitation is not yet developed. Hot water sources would require a heat engine operating between smaller temperature differences than traditional power turbines. A working fluid other than water would likely be used. Fouling of heat exchangers by the minerals of the hot water source may be a problem. One of the largest sources of hot water energy is in the Imperial Valley of southern California. The output of this region could be as high as 30,000 MW (3-27).

The third source of geothermal energy is from hot rock found in certain geological regions. In these regions, there is insufficient water in the hot structure to provide hot water or steam. Proposed schemes involve sinking two wells; the first, 8000 to 20,000 feet deep, would be used to inject water. Water injected through the first well would flow through the porous structure of the hot rock. As the water heats up, its density will decrease and it will be carried upward by convection where it will be extracted through the second, more shallow well. The energy content of promising hot rock sources in the western United States has been estimated to be 10^{17} kWh.

Geothermal sources are not the perfectly clean source of power that many would like to believe. Steam and water from subsurface sources often carry corrosive and/or odorous impurities. However, the impact of these impurities can be minimized, making geothermal power environmentally desirable. Many of the minerals removed from the heat source have economic value, aiding the economics of this power scheme.

The relatively low temperature of any geothermal source (less than 700° C) suggests that the most likely path for the production of hydrogen from geothermal energy is through the heat engine-electricity-electrolysis path. Because two of the most promising geothermal locations are near major load centers (Imperial Valley near Los Angeles and Geysers near San Francisco), the economic advantage of the low transmission costs of hydrogen energy will not likely be an impetus to the development of geothermal-hydrogen systems in the near future. When larger and more remote

geothermal sources are developed through the exploitation of hot rock, the production of hydrogen could be the economical way to distribute the energy. Large quantities of electrical energy at 15 mill per kWh from hot rock, would permit the production of hydrogen for \$5.01 to \$4.66 per 10^6 Btu (using previous electrolysis data).

3.3.5.3 BIOCONVERSION OF ORGANIC WASTES

A biological method of producing hydrogen from organic wastes has been suggested utilizing the photosynthetic system. Blankenship and Winget (3-28) have proposed that hydrogen be produced by certain algae and/or bacteria, if they are placed in a substrate of organic waste material. The metabolism of these micro-organisms depends upon the photosynthetic process and, thus, requires sunlight. However, since part of the energy input to the system is from the organic waste material substrate, the energy output in the form of hydrogen is greater than the energy input of direct solar energy. The area of solar energy collection can then be less than the area required for a purely solar energy process.

Calculations based on experimental results with the photosynthetic bacterium *R. Rubrum* show that a net volume of about 1,800 liters per hour of waste is needed. Spread over an area of about 180 square meters (1800 ft²) this would release enough energy to supply the needs of a typical home. The household sewage system can be used as a growth medium for the bacteria. Such a method would not only serve as an energy supply, but would also reduce solid waste pollution. The technical and economic feasibility of this method needs to be established and it consequently merits further consideration. Recommendations for the development of this energy source are made by the NSF/NASA Solar Energy Panel.

The bioconversion of organic wastes is only one method of utilizing the energy of waste products. A more complete picture of energy supply from wastes and appropriate processing methods is given by Maugh (3-29). Although this energy source appears environmentally attractive, Maugh maintains that such energy sources can supply only a few percent of our total energy demand in the future.

3.4 CONVERSION PROCESSES

3.4.1 ELECTROLYSIS OF WATER

Methods of generating hydrogen that are reliable, efficient and cost-effective must be available for the concept of hydrogen as an energy carrier to be feasible. One such method in commercial practice today is electrolysis, depicted in Figure 3-4.

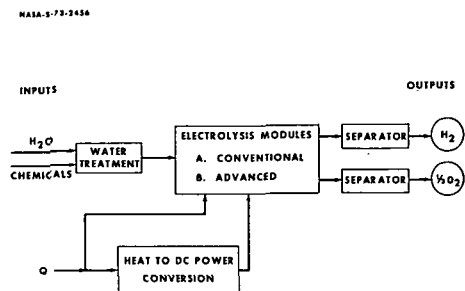

FIGURE 3-4
ELECTROLYSIS SCHEMATIC

The manufacture of hydrogen by electrolysis is quite expensive when existing technology and the present cost of electricity are used (3-30). Conventional water electrolysis cells are characterized by the necessity of restricting current densities to values under 200 amperes per square foot (ASF) and even the promise of cheap power from a nuclear or other source is not a sufficient economic reason to justify this process. The higher cost of this method restricts electrolysis to areas of the world such as Canada, Norway, Egypt and India where there is either a cheap abundance of hydroelectric power or no natural gas source (3-31). In addition, because the major part of the energy cost of producing hydrogen by electrolysis is determined by the cost of electricity, the energy cost of electrolytic hydrogen will always be higher than that of electricity (3-32).

We turn now to the discussion of the theoretical limitations of electrolysis, as well as the criteria for evaluating electrolyzer cells. Since the overall process of water electrolysis is the reverse of the combustion of hydrogen, the energy required is theoretically the same as the heat of combustion. This corresponds to 245 kWh per 10^6 Btu of hydrogen produced for a perfectly efficient cell. If we define the electrolytic cell efficiency as the ratio of the heating value of the hydrogen output to the electrical energy input, present cells operate at 60 to 70 percent efficiency (3-33, 3-34).

For the water electrolysis process, the voltage corresponding to the enthalpy change is 1.47 volts at 298° K while the cell voltage corresponding to the free energy change is only 1.23 volts. Thus, only 1.23 volts are theoretically required to generate hydrogen and oxygen from water. Ideally then, one could obtain a 120 percent electrolytic efficiency; the remainder of the energy required being obtained from ambient heat. The free energy change varies with the temperature, in favor of cells operating at elevated temperatures. At high enough

temperatures (500 to 600° K) the cell potential drops to 1.0 volt, further reducing the theoretically required electrical energy input (3-33).

Capital costs of electrolyzer cells are dominated by the size and unit cost of the electrodes. To get a high hydrogen output, the cell must be operated at a very high current density, perhaps 1000 ASF or greater, but higher voltages are required and the electrolytic efficiency decreases.

We now distinguish between two types of electrolyzer technology, conventional and advanced, based on the above criteria. Cells of conventional technology operate at ambient conditions and atmospheric pressure with low current densities (3-35). As stated earlier, their efficiency is low, typically 60 to 70 percent. The advanced concepts (3-36, 3-37) use a combination of improved electrodes, new electrolytes, and high temperatures and pressures both to reduce the capital cost of the cell and to improve the current density, as well as to increase the efficiency of the overall process. An advanced cell schematic is given in Figure 3-5.

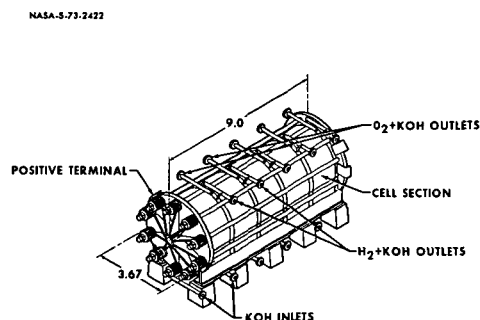

FIGURE 3-5
ADVANCED ELECTROLYSIS CELL

Electrolysis efficiency is critically dependent on lowering electrode overpotentials and minimizing ohmic losses at high current densities. Various approaches use aqueous or solid phase electrolytes, liquid or vapor phase water input, acidic or alkaline electrolytes, and various temperature or pressure ranges to achieve the desired characteristics (3-38). Materials problems are also inevitable for electrolytic systems. The organic solid electrolyte developed by General Electric (3-39) in conjunction with NASA's fuel cell development program appears promising from its demonstrated reliability and low degradation rate. Another principal difference between conventional technology and the advanced technology is in electrode development. Most of the advanced cells use very porous, high surface area metal electrodes carrying a highly developed nickel, silver or platinum catalyst.

In the United States, one manufacturer (Teledyne Isotopes) markets an advanced cell design, developed through various Allis-Chalmers contracts for the Army and the Air Force. This electrolyzer uses potassium hydroxide as the electrolyte with a porous nickel electrode at the modest temperature of 400° K. Predictions of design performance are difficult to make with this cell since Teledyne has not been able to achieve the earlier optimism shown by Allis-Chalmers (3-33).

The General Electric Company has developed a "Solid Polymer Electrolyte Technology" (SPE) in which a solid plastic sheet of cation exchange membrane about 12 mils thick saturated with water is the electrolyte. The absence of free acid or alkaline liquids in the system minimizes corrosion problems. A number of advantages are claimed for this system including cell operation at high pressures (1000 psia), fixed electrolyte concentration, and minimum power requirement per unit of gas generated. Another feature of the SPE cell is the simplicity of the catalytic electrodes which consist of a thin layer of platinum black attached to one SPE surface and a proprietary alloy catalyst on the other surface. A performance of 1800 asf operating current density at 380° K and 2.15 volts is claimed for over 7000 hours of operation, with no loss in capability of hydrogen generation (3-32).

Projected potential for further reduction in both energy requirements and capital cost for producing hydrogen have been examined by Gregory (3-33), Hausz (3-38, 3-40), Titterington (3-39) and others (3-34, 3-41, 3-43). The projections through 1985 are straight-forward extensions of the present advanced technology. Input energy reductions will be obtained through electrode improvements and an increase in the operating temperature to 500° K. Capital cost reductions are envisioned through reductions in the quantity of noble metal used and cost of cell hardware materials. Beyond 1985, solid oxide electrolytes with the capability of operating at 800° K (3-32) may become available.

The economics of hydrogen production by electrolysis have been discussed by several authors (3-30, 3-33, 3-36, 3-40, through 3-43). Mrochek at the Oak Ridge National Laboratory (3-30) discussed two advanced cell concepts for a hydrogen plant producing 40 million scf per day at an outlet hydrogen pressure of 1700 psia. These calculations were reviewed by Gregory (3-33) and a revised cost estimate produced. The Oak Ridge study (3-43) derived an estimated manufacturing cost of \$1.03/10⁶ Btu which has since been widely used in Atomic Energy Commission (AEC) cost estimates. This figure is based on the unrealistically low electric power price of

2.5 mills per kWh compared to an average generating cost today of about 8 mills per kWh. Gregory (Institute of Gas Technology (IGT) in Chicago) has revised the AEC cost estimates based on present costs of utility financing and some optimistic projections of lowered plant costs for electrolysis (3-33). Costs between \$1.50 and \$2.50/10⁶ Btu were obtained with electricity costs at a price between 4 and 7 mills per kWh. Decreased hydrogen costs may be realized if credits from the sale of oxygen and heavy water, both of which are produced as by-products, are taken into account.

Estimates prepared by General Electric - TEMPO (3-38) indicate costs of producing electrolytic hydrogen as \$2.39/10⁶ Btu in the year 2000. These costs assume electricity derived from nuclear power. Titterington (3-39) estimates costs of SPE-generated hydrogen as \$1.79/10⁶ Btu by 1985 and \$1.35/10⁶ Btu with electric power at 5 mills per kWh by the year 2000, corresponding roughly to those figures given in the G.E.-TEMPO studies.

Michel (3-44, 3-45) of the Synthetic Fuels Panel has reviewed the economics of hydrogen production for electrolytic processes (Figure 3-6). The major amount of the cost, 84 percent, is due to the cost of electricity. A price of \$3.68/10⁶ Btu was obtained for power at 8 mills per kWh dropping to \$2.33/10⁶ Btu using advanced electrolyzer concepts. Including credits for by-product oxygen (estimated at \$8.00/ton), the price of electrolytic hydrogen drops still further to \$1.74/10⁶ Btu. This price is even lower than that estimated for hydrogen derived from off-peak power (discussed below), if such a commodity exists, at 2.5 mills per kWh. These estimates agree fairly well with the ones projected by our study group in Section 3.6.

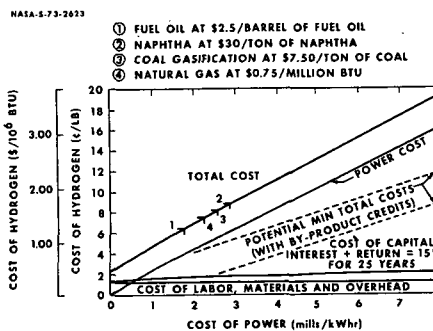

FIGURE 3-6
 ECONOMICS OF HYDROGEN
 PRODUCTION BY ELECTROLYSIS

ORIGINAL PAGE IS OF POOR QUALITY

One can roughly summarize the cost picture for electrolytic hydrogen by stating that the real cost of hydrogen is directly influenced by the cost of electrical energy. At present, advanced electrolyzer technology holds a promise for lower capital cost and higher efficiencies than conventional technology, but this promise will not decrease hydrogen costs enough to offset the basic cost, which is that of electricity from which to generate hydrogen. Currently, with today's electrical costs, hydrogen costs run about \$3.00 to 4.00/10⁶ Btu, these costs are expected to drop to about \$2.00/10⁶ Btu in 1985 with improvements in electrolyzer technology and perhaps to \$1.50/10⁶ Btu by the year 2000, if optimistic projections are realized. Present day fossil fuel hydrogen costs are estimated at \$1.00 to 1.50/10⁶ Btu (3-40) and until the price of coal increases drastically, electrolytic hydrogen may not be economically competitive.

It has been suggested that hydrogen could be cheaply produced by electrical generation plants during off-peak periods. This idea may have originated in regard to hydroelectric plants and may have currency resulting now from reports that only about 50 percent of the total generation capacity is used for base-load power generation. While there may be some special cases where low cost off-peak power is available, sufficient quantities of low cost hydrogen could not be so produced. In a typical installation it is true that base load capacity represents about 50 percent of installed capacity; but it is set to operate at a fixed level, generating 70 to 75 percent of the electrical energy demand. The remaining 25 to 30 percent of demand is met by intermediate and peaking installations.

Intermediate load installations follow the daily variations in load; peaking installations follow the hourly fluctuations in load. Thus, both do have unused capacity and could generate additional electrical energy for hydrogen production if operated continuously at full capacity (Figure 3-7). The problems, however, are with the amount and the cost. Using these units (which are only 25-30 percent of total electrical generating capacity) would fail to produce significant quantities of hydrogen (3-47). This is hardly a solution to the energy shortage. Furthermore, the intermediate and peaking units have high operating costs and generally use expensive and increasingly scarce fossil fuels. Therefore, except in a few special cases, hydrogen could not cheaply be so produced. It has also been proposed that there is a possibility that new power plants or additions could be sized to produce both base and intermediate loads as well as power to produce hydrogen. Production of hydrogen would then fluctuate inversely with the demand for electrical

energy. Unfortunately, however, hydrogen produced from this type of operation still would not be cheap because economics of scale for power plants are reaching a point of diminishing returns. Larger sized plants no longer produce a significant lowering of the capital costs per kilowatt or lowering of the cost of energy per kilowatt hour.

NASA-1-73-2507

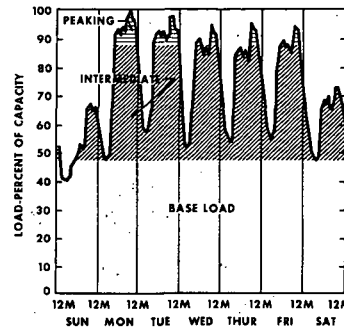

FIGURE 3-7
TYPICAL WEEKLY POWER
GENERATION LOAD CURVE

3.4.2 THERMOCHEMICAL DECOMPOSITION OF WATER

3.4.2.1 THERMOCHEMICAL - OPEN CYCLE

The combustion of fossil fuels for energy is an open cycle process since the rate of fuel usage is orders of magnitude greater than the rate of fuel formation by fossilization. As discussed in Section 3.3.3 comments here are directed to the use of coal.

The direct combustion of coal to produce energy is not attractive, except for stationary applications, because of solids handling problems. Even for stationary applications, care must be taken in cleaning gaseous emissions to prevent flyash and sulfur oxide contamination of the environment. Processes for conversion of coal into cleaner burning fuels have been under study for a number of years. Products from such processes may include synthetic natural gas (SNG, primarily methane), synthetic crude oil, coal char, synthesis gas (mixture of hydrogen and carbon monoxide), and pure hydrogen. As shown in Figure 3-8, two possibilities exist by which these processes could utilize coal in a hydrogen economy.

Given a source of hydrogen (such as thermal, chemical, or electrical water splitting), coal can be directly hydro-treated to produce a variety of hydrocarbons very similar to those in use as fuels today. Alternatively, in the absence of such a hydrogen source, or perhaps in transition from a fossil energy base to

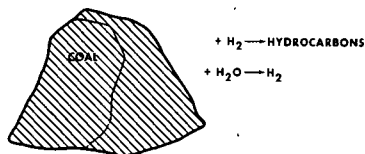

FIGURE 3-8
POSSIBILITIES FOR COAL UTILIZATION
IN A HYDROGEN ECONOMY

nuclear or solar energy with hydrogen as an energy carrier, coal could be gasified with steam to produce hydrogen for distribution. A portion of this hydrogen might be combined with additional coal to produce conventional hydrocarbon fuels as in the first case.

These two approaches are compatible with the hydrogen economy concept because they both depend on hydrogen being generated in large quantity. Neither approach can be considered the ultimate answer to the energy crisis, however, since in both cases the coal will eventually be depleted. The degree to which these approaches might be used will depend largely on the tradeoffs, economic and otherwise, between methane and hydrogen produced from coal, the availability of a hydrogen source independent of coal, and upon public reaction to hydrogen as an energy carrier.

Hydrocarbon feedstocks for the chemical process industries as well as hydrocarbon fuels for transportation may be synthesized from hydrogen and coal, although, as discussed in Chapter 5 of this report, many transportation modes may eventually utilize other synthetic fuels such as ammonia.

The two alternatives will be discussed in more detail below.

Conventional Fuels from Hydrogen and Coal

A possible schematic for a coal hydro-treating plant is shown in Figure 3-9. The relative amounts of the various products from such a plant would depend on the process configuration and processing conditions. Several conversion steps are required in producing gasoline from coal (3-48). These are:

- the transformation of solid coal to a liquid form
- the removal of ash, sulfur, nitrogen, and oxygen
- molecular hydrogenation and cracking
- octane improvement.

NASA-673-2593

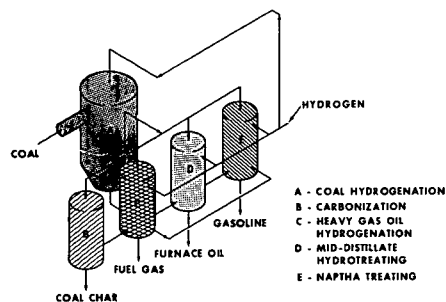

FIGURE 3-9
HYDROGENATION OF COAL TO PRODUCE
CONVENTIONAL HYDROCARBONS

For lower grade fuel oils less hydrogenation and cracking is required. Liquefaction of coal may be accomplished by hydrogenolysis, pyrolysis to coal tar, or by dissolution in a hydrogen donor solvent.

A considerable research effort in this area has been directed by the Office of Coal Research since the early 1960's. Current research and development funding as well as a list of past reports available are included in their recent annual report (3-17). Plans for the coming year include reactivation of the Project Gasoline (3-49) pilot plant to maximize production of clean, low sulfur fuel oil; continuation of support to the COED (Coal-Oil-Energy Development) program (3-50) which utilizes pyrolytic liquifaction of coal and subsequent hydrogenation to produce fuel gas, synthetic crude oil, and coal char; and start-up of a pilot plant which will solvent refine 50 tons of coal per day to ashless, low-sulfur fuel (3-51). Earlier studies included the CONSOL synthetic fuel process (3-52), the H-Coal hydrogenation process (3-53), and project Seacoke - a study of the hydrotreating of coal derived liquids (3-54).

In addition to these efforts to produce synthetic petroleum liquids from coal, there is a considerable amount of research and development emphasis at the present time to find an efficient process for gasifying coal to pipeline quality gas (methane). In 1971 a four year agreement between industry (American Gas Association) and the Office of Coal Research was signed. Under this agreement \$120 million will be expended to advance coal gasification technology. By 1975 three pilot plants using different processes will be in operation for comparison (3-17). Progress on the various processes being studied has been recently reviewed (3-55, 3-56, 3-57). The processes and their current status are shown in Table 3-5. Most of these processes are similar, in that coal is converted to synthesis gas

TABLE 3-5
TABULATION OF BETTER KNOWN COAL GASIFICATION PROCESSES

Name	Developer	Heat Input	Pressure, psig	Reactor Type	Status
Lurgi	Lurgi	Oxygen	300- 500	Settling bed	Advanced version near demonstration
HYGAS	Institute of Gas Technology	Oxygen or Electrical	1,000-1,500	Fluidized bed	80 ton/day pilot plant successfully demonstrated
BI-GAS	Bituminous Coal Research, Inc.	Oxygen	1,000-1,500	Entrained/slugging	will build 120 ton/day pilot plant
CO ₂ Acceptor	Consolidation Coal Company, Inc.	Air/Dolomite	150- 300	Fluidized bed	30 ton/day pilot plant in operation
Molten Carbonate	Kellogg	Oxygen/Air	1,200	Molten salt	have bench scale data
Atgas	Applied Technology Corporation	Oxygen/Air	50	Molten iron	have bench scale data
Synthane	Bureau of Mines	Oxygen	600,1,000	Entrained/fluidized bed	will build 72 ton/day pilot plant
Hydrane	Bureau of Mines	Oxygen	1,100	Entrained/fluidized bed	have bench scale data
COGAS	FMC Corporation	Air	50- 200	Entrained/fluidized bed	have bench scale data

(carbon monoxide and hydrogen) which is then reacted in the presence of a catalyst to give methane. Several of these (Hy-Gas, Synthane, Hydrogasification) have the feature that methane is produced directly in relatively large amounts by the reaction of hydrogen with coal. The hydrogen in these cases is produced by the reaction of steam with coal and is recycled to the hydrogasification step.

Processes of this type could be used to produce substitute natural gas and synthetic petroleum liquids from coal and a non-coal hydrogen source such as might be available in a hydrogen economy. This would result in much more efficient utilization of our coal reserves than would be the case if the hydrogen were generated using additional coal. The ultimate in efficient usage of coal reserves, however, will be realized if their use as fuel is minimized by substituting, where possible, non-carbon base hydrogen carrier fuels, such as hydrogen and ammonia.

Hydrogen from Coal

Pure hydrogen can be produced by the reaction of steam with coal. A schematic for such a process is given in Figure 3-10.

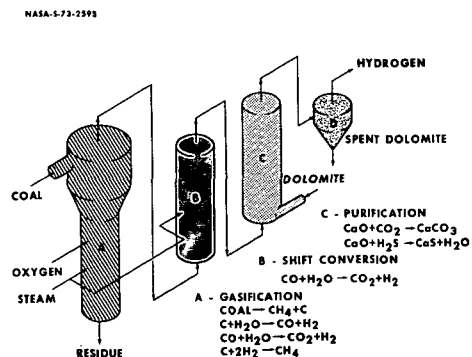

FIGURE 3-10
COAL GASIFICATION TO PRODUCE HYDROGEN

The chemistry, also shown, is essentially identical to that encountered in the production of methane from coal except that process conditions and configuration favor a distribution of products rich in hydrogen. (Generally speaking hydrogen formation is favored by higher temperatures and lower pressures whereas methane formation is favored by lower temperatures and higher pressures.) Hydrogen could be produced by this procedure for a hydrogen economy for a period of time even if no long-term primary energy source becomes available. Or, in anticipation of a long-term primary energy source being used in a hydrogen economy concept, hydrogen produced from the reaction of steam with coal could be used in the period of transition.

A review of work being done in the area of power gas generation, compatible with this concept, will soon be published by the Office of Coal Research (3-60). Power gas is comprised largely of a mixture of carbon monoxide and hydrogen. For stationary power plant usage, there is no incentive for removing the carbon monoxide since its heating value is essentially the same as that of hydrogen. Because of complications involved with handling mixtures, and, since carbon monoxide is very toxic, the carbon monoxide can be shift-converted to hydrogen in the hydrogen economy concept. It is the objective of the Office of Coal Research to make this power gas technology available on a commercial scale by 1980.

Because of the large number of variables involved, it is difficult, in general, to give projected costs for fuels produced by these methods. It is clear, however, that as the supply of convenient fossil energy forms (natural gas and petroleum) is diminished and the demand for energy increases, coal will become econo-

mically attractive for more uses and will be utilized to a much greater extent. As is shown in Figure 3-11, estimates for the cost of hydrogen from coal (curves a, b, c) are in line with estimates for the cost of SNG produced from coal (curves d-h). Wentorf and Hanneman (curve a) (3-44) predict hydrogen cost to be in the \$1.00 to \$.40/10⁶ Btu range, including sulfur removal, for processes which have thermal efficiencies in the range of 60 to 70 percent. Curve b was generated by coupling an AEC panel (3-45) economic analysis of the CO₂ Acceptor Process (to produce hydrogen) with coal price projections (\$.50/10⁶ Btu by 1995) given by Gregory (3-33). Curve (c) was similarly derived assuming coal costs to be half those projected by Gregory. Line (d) is a 20 year average presented by Papamarcos (3-57) for the cost of SNG produced from 12,600 Btu/lb coal at \$.30/10⁶ Btu in an ATGAS coal gasification plant. This line also corresponds to Siegel and Kalinas' (3-58) 20 year estimate for SNG production from western coal using the Lurgi process. Line (e) is for the same conditions assumed by Papamarcos but with coal available at \$.20/10⁶ Btu. Line (f) was derived by Siegel and Kalina for producing SNG from bituminous coal using the Lurgi process. They predict 5 to 15¢/10⁶ Btu savings for new process technology now being developed, and appreciable additional incremental costs depending on the type of financing, operating costs and date of plant startup. Wen, et al. (3-56), provide an internally consistent comparison of nine process alternatives with both bituminous and lignite coal available at various prices. Curves (g) and (h) correspond respectively to their least and most expensive alternatives. Alternative II-2 is direct hydrogasification and I-1 is methanation of synthesis gas. Gregory's coal costs were assumed to apply.

There are several problems associated

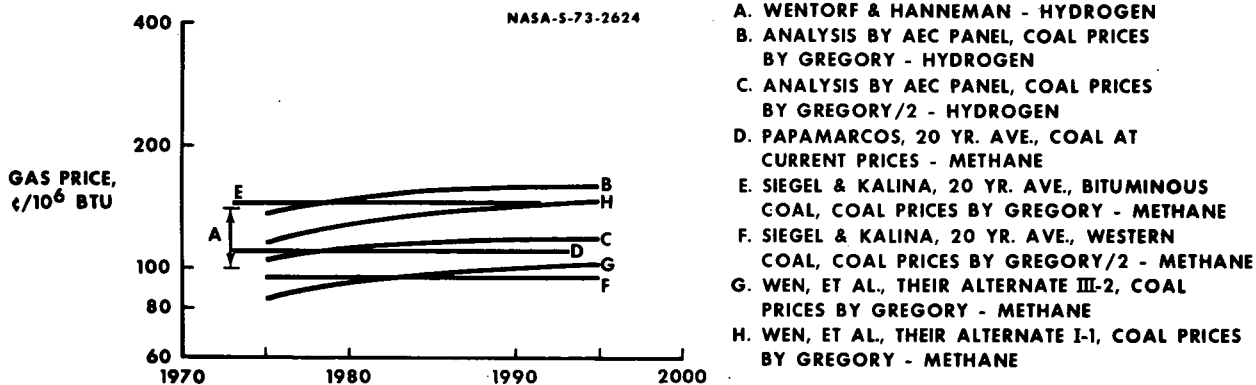

FIGURE 3-11
COST OF HYDROGEN AND METHANE FROM COAL

with the large scale use of coal. The problems as discussed below are independent of the hydrogen energy concept and must be faced if coal is to be extensively used in the future.

Problems Involved with Large-Scale Use of Coal Reserves

Environmental problems associated with large-scale coal utilization derive from both the mining and conversion processes. Coal is currently mined by two methods, depending largely upon the type of deposit and its location. These are underground tunneling or deep-mine methods, and strip mining.

Deep mining is a hazardous occupation and is costly since operations must follow rigorous guidelines set by the Federal Mine Health and Safety Act. Because this act has had the effect of reducing deep mine productivity, it is clear that more effective and safe methods of underground mining need to be developed and implemented.

Strip mining, while safer than deep mining, is applicable only to coal reserves relatively near the earth's surface. This method of mining is expensive because of the necessity to reclaim stripped land. Estimated reclamation costs for western coals range from \$.02 to \$.17 per ton of coal, while that for eastern coals range from \$1.00 to \$2.00 per ton (3-61, 3-62).

In light of problems associated with these methods of mining, serious consideration should be given to the possibility of in situ coal gasification. Recent work (3-63) suggests that problems associated with previous attempts using this method may be overcome. The concept is that coal may be gasified in place in the ground by pumping steam and oxygen (or hydrogen) into a fractured deposit as shown in Figure 3-12.

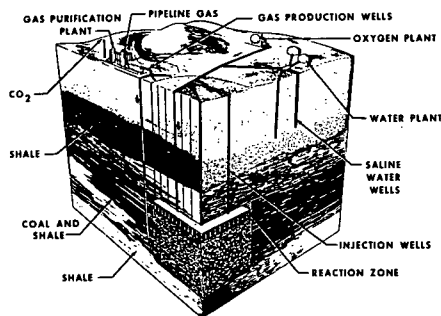

FIGURE 3-12
IN SITU COAL GASIFICATION

The rate of gasification would be controlled by the rate of injection of steam and oxygen (or hydrogen). Product gases are collected

by wells, terminating at the opposite end of the deposit. Expenses associated with mine safety and land reclamation would be greatly reduced if such a method proves feasible.

Regardless of the mining method used, coal gasification will require large amounts of water. A National Academy of Sciences study committee on the Rehabilitation of Arid Lands has studied this situation in some detail (3-64). They conclude that availability of water may prove to be the limiting factor in the development of western coal fields, particularly in the more arid regions of Arizona, New Mexico, Utah, and Colorado.

Direct use of coal as a source of energy has been restricted to electrical power generation because of solids handling problems and problems associated with the production of sulfur dioxide and flyash, all deleterious to the environment. With coal gasification, all these problems apply to the conversion process but their impact on the environment is minimized due to the centralization of conversion plants. All may prove to be insignificant should in situ gasification become feasible.

Another serious problem facing the coal industry is lack of personnel, particularly engineers, to work on the technical problems involved. The number of students enrolled in mining and mineral engineering programs has been steadily decreasing and has resulted in the demise of several teaching programs. This must be overcome quickly if we are to effectively utilize our coal reserves because there is a four year lag between demand and supply in the university educational system. The time lag may be even more serious at the onset because of the necessity to establish completely new programs of instruction.

3.4.22 THERMOCHEMICAL - CLOSED CYCLE

Thermochemical water decomposition by closed-cycle processes has been the subject of increasing interest over the last 5 to 10 years. Close to thirty such schemes have been suggested in the literature and work is in progress on definition and development of these processes at the Euratom facilities in Ispra, Italy; the Nuclear Research Center of Juelich West Germany; Los Alamos, Brookhaven and Argonne Laboratories; the Institute of Gas Technology; and the GE Research Laboratories in the United States, among other places.

A chemical cycle resulting in production of hydrogen and oxygen from water with no net consumption of other chemical species is a very attractive process for the following reasons:

- An infinite supply of raw material is available. The only expendable chemical in the process is water.
- Since little or no work is required in a chemical cycle, there are no inefficiencies associated with the conversion of large quantities of heat into useful work, such as electricity.
- Heat is required at temperatures which are available with present or foreseeable advances in technology, either from nuclear reactors or solar collectors.
- No major technological breakthroughs are needed to get a feasible chemical process from a conceptual stage to an onstream status. The rapid development of the petrochemical and polymer industries attests to the fact that modern chemical engineering has the necessary tools for process development on a relatively short term basis.

Several authors have studied the thermodynamics of closed-cycle water splitting processes in an effort to establish criteria for feasibility of different schemes from an energy standpoint.

Funk and Reinstron (3-65, 3-66), Kerns (3-34), and Knoche (3-67) have shown in effect that it is possible to operate a sequence of chemical steps with no net work requirements at temperatures well below the temperature required for water dissociation in a single step. The situation is best illustrated in Figure 3-13.

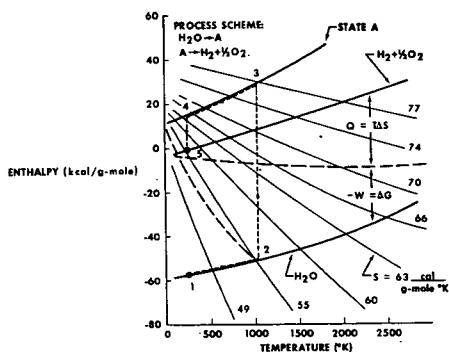

FIGURE 3-13
ENTHALPY-TEMPERATURE DIAGRAM
FOR WATER DECOMPOSITION

Solid lines designated "H₂O" and "H₂ + 1/2 O₂" represent the thermodynamic state of water vapor and a stoichiometric mixture of hydrogen and oxygen resulting from water decomposition. The vertical distance between these two state lines is the enthalpy change in going, at any temperature, from the initial state of water to the final state. This change in enthalpy can be brought about by the combination of heat (TAS) and work (-ΔG) in the proportions indicated by the broken line (Q-W) running between the two state lines. Any chemical reaction can be characterized by these three lines in the H-T diagram.

Water vapor dissociation at room temperature involves an enthalpy change of 57.8 kcal/g mole between states 1 and 5. Over 90 percent of this enthalpy change has to be brought about by supplying useful work, such as in an electrolysis cell. In a two reaction scheme, however, it is possible in principle to go through an intermediate state A with only the addition of heat (path 1-2-3-4-5). This is possible by carrying out the first reaction in the cycle at a temperature above the intersection of its Q-W line, (Q-W)₁, with the reactants enthalpy curve. Several unsuccessful attempts have been reported in the literature on search for such an intermediate state A. Oxides and hydrides for instance, show Q-W lines that result in zero work requirements at unreasonably high temperatures (3-66). Basically the same situation arises with halide-water reaction schemes (3-37).

The possibilities of minimizing the work requirements are increased many-fold as we go to three, four, and five step reaction schemes. The same thermodynamic considerations apply to every reaction in the sequence and the net enthalpy, entropy, and free energy changes must equal those of the one-step water decomposition. Net work requirements will of course be different since work is not a state function.

If we extend these work-saving concepts illustrated in Figure 3-13, the following generalized criteria result for multi-step processes in closed cycle thermochemical water-splitting:

- The highest temperature reaction in an n-reaction scheme should have a positive entropy change.
- No n-reaction scheme going from State 1 to State 2 in a clockwise direction will result in less work requirements than water electrolysis.
- Any part of an n-reaction scheme that runs clockwise in the H-T

diagram results in a larger work requirement than an alternate counterclockwise running path between the same initial and final states.

These criteria are briefly sketched in Figure 3-14. Figure 3-15 shows H-T diagrams

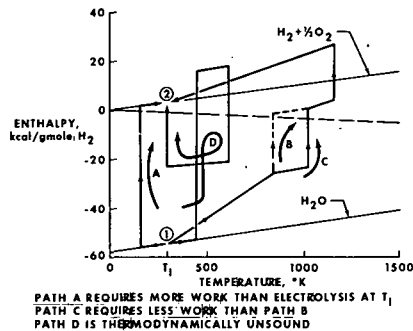

FIGURE 3-14
THERMODYNAMIC CRITERIA FOR
MULTISTEP WATER SPLITTING

for three multi-step processes that have been extensively studied and reported in the literature. They all conform to our criteria that viable and thermodynamically sound processes should run in a counterclockwise direction everywhere in the H-T diagram.

The above discussion is not meant to imply that closed cycle processes can be devised with no net work requirements. The condition that all species, but water, must be recirculated imposes a restriction in the minimization of work requirements for all multistep closed cycle processes. This involves separation and recirculation of unconverted reactants in every reactor in the process. Even for reactions carried out at temperatures which assure virtually total conversion, the closed cycle nature of the overall process imposes separation work requirements.

Theoretical work of separation can be a substantial burden on overall energy requirements and, thus, decrease overall process thermal efficiency. The latter is usually defined as the ratio of heat of combustion of hydrogen produced to the total energy requirements of the process. One reaction that enters into several of the proposed schemes, for instance, is the production of hydrogen chloride and oxygen from chlorine and water, the reverse Deacon reaction. We have calculated theoretical work requirements for separation to be 40 percent and 25 percent of the heat of reaction at 700 and 1000° K, if separation is carried out at 200° C by thermal means. The requirements would even be larger if the separation energy requirements have to

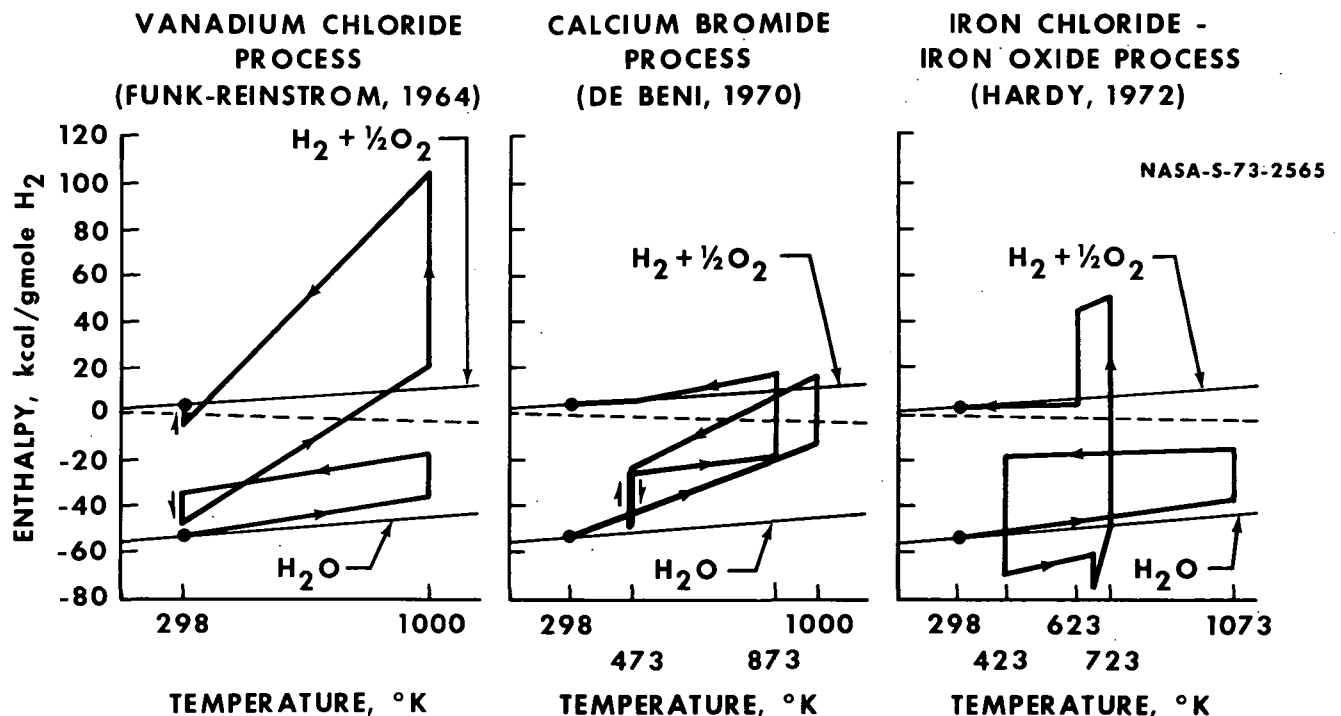

FIGURE 3-15
THREE MULTISTEP WATER SPLITTING PROCESSES (H-T DIAGRAMS)

go through a heat to work conversion. This makes all reported efficiency values in the literature very optimistic.

We turn our attention now to the processing schemes that have been reported in the literature. We have made an attempt to classify these processes into families. Tables 3-6 to 3-10, to follow, list some of the most promising schemes with the appropriate references. We have excluded from these tables the many variations from these basic reaction sequences that have been advanced at a later date, unless such variations have resulted in much more straight forward processing schemes. The bulk of these processes are presently conceptual or in an early stage of development, and most of them have not been demonstrated in the laboratory. For this reason capital cost data and process efficiencies are not generally available.

Halide Processes

Some of the most promising closed cycles for water decomposition have been based on the chemistry of halide compounds. Four such processes are shown in Table 3-6.

The first of these processes, using calcium bromide and hydrochloric acid, has been the subject of intensive investigation at the Euratom facilities at Ispra, Italy. It was first reported and named "Mark 1" by De Beni (3-68) in 1970 and has since been reviewed in literature several times (3-33, 3-34, 3-69, 3-70). The reaction temperature of this cycle, 730° C, is well within the range of present high temperature gas cooled reactors, as well as projected cool- and temperatures of more advanced nuclear reactors and possibly linear solar collectors. A thorough discussion of the current work in progress by Euratom at Ispra for the development of the Mark 1 process can be found elsewhere (3-71). De Beni and Marchetti (3-70) estimate efficiencies in the Mark 1 process in the order of 40 to 60 percent lower heating value, (LHV). In their 1972 report (3-71) they calculate a requirement of 614 MW from a nuclear reactor for the production of 100,000 m³ of hydrogen, which represents an efficiency of 49.3 percent (LHV).

Perhaps the most serious shortcomings of the Mark 1 process are materials requirements for handling hydrobromic acid

TABLE 3-6
HALIDE PROCESSES

° CALCIUM BROMIDE PROCESS	
De Beni, Euratom, 1970	
CaBr ₂ + 2 H ₂ O → Ca(OH) ₂ + 2 HBr	730°C
Hg + 2 HBr → HgBr ₂ + H ₂	250
HgBr ₂ + Ca(OH) ₂ → CaBr ₂ + HgO + H ₂ O	200
HgO → Hg + 1/2 O ₂	600
° STRONTIUM BROMIDE PROCESS	
De Beni, Euratom, 1970	
SrBr ₂ + H ₂ O → SrO + 2 HBr	800°C
2 HBr + Hg → HgBr ₂ + H ₂	200
SrO + HgBr ₂ → SrBr ₂ + Hg + 1/2 O ₂	500
° MANGANESE CHLORIDE PROCESS	
De Beni, Euratom, 1972	
6 MnCl ₂ + 8 H ₂ O → 2 Mn ₃ O ₄ + 12 HCl + 2 H ₂	700°C
3 Mn ₃ O ₄ + 12 HCl → 6 MnCl ₂ + 3 MnO ₂ + 6 H ₂ O	100
3 MnO ₂ → Mn ₃ O ₄ + O ₂	900
° IRON CHLORIDE PROCESS	
Hardy, Euratom, 1972	
6 FeCl ₂ + 8 H ₂ O → 2 Fe ₃ O ₄ + 12 HCl + 2 H ₂	650°C
2 Fe ₃ O ₄ + 3 Cl ₂ + 12 HCl → 6 FeCl ₃ + 6 H ₂ O + O ₂	175
6 FeCl ₃ → 6 FeCl ₂ + 3 Cl ₂	420

and the large inventory and contamination possibilities inherent in the use of mercury. This has prompted consideration of other alternatives which would modify the Mark 1 process. One such alternative considers using copper instead of mercury at the expense of higher temperatures for the decomposition of the oxide. In another instance the second reaction is carried out in two steps with a substantial reduction of mercury inventory.

The second process in Table 3-6 is to some extent, a variation of the Mark 1 process which involves using strontium instead of calcium bromide. The cycle is carried out in three steps. The advantage of strontium bromide stems from the possibility of carrying out the third reaction in the solid-gas phase, which results in a lower

concentration of hydrogen bromide and a mitigation of corrosion problems. This process has been patented by De Beni (3-68) and is under study by the Euratom group.

The third and fourth halide processes use manganese chlorides and iron chlorides and oxides at somewhat higher temperatures, as reported by Hardy (3-72). Several variations of the latter have been presented (3-71), all having in common a step for the hydrolysis of ferrous chloride.

Reverse Deacon Processes

Several processes, depicted in Table 3-7, have been built around the reaction of chlorine gas and water to form hydrochloric acid and oxygen. The opposite reaction, the oxidation of hydrochloric acid,

TABLE 3-7
REVERSE DEACON PROCESSES

° VANADIUM CHLORIDE PROCESS		
Funk and Reinstrom, Allison Div., G.M., 1964		
$H_2O + Cl_2 \rightarrow 2 HCl + 1/2 O_2$		700°C
$2 VCl_2 + 2 HCl \rightarrow 2 VCl_3 + H_2$		25
$4 VCl_3 \rightarrow 2 VCl_4 + 2 VCl_2$		700
$2 VCl_4 \rightarrow 2 VCl_3 + Cl_2$		25
° IRON CHLORIDE PROCESS		
De Beni, Euratom, 1972		
$H_2O + Cl_2 \rightarrow 2 HCl + 1/2 O_2$		700°C
$2 HCl + 2 FeCl_2 \rightarrow 2 FeCl_3 + H_2$		600
$2 FeCl_3 \rightarrow FeCl_2 + Cl_2$		350
° IRON CHLORIDE - IRON OXIDE PROCESS		
Hardy, Euratom, 1972		
$3 H_2O + 3 Cl_2 \rightarrow 6 HCl + 3/2 O_2$		700°C
$3 Fe_2O_3 + 18 HCl \rightarrow 6 FeCl_3 + 9 H_2O$		120
$6 FeCl_3 \rightarrow 6 FeCl_2 + 3 Cl_2$		420
$6 FeCl_2 + 8 H_2O \rightarrow 2 Fe_3O_4 + 12 HCl + 2 H_2$		650
$2 Fe_3O_4 + 1/2 O_2 \rightarrow 3 Fe_2O_3$		350
° COPPER CHLORIDE PROCESS		
$H_2O + Cl_2 \rightarrow 2 HCl + 1/2 O_2$		700°C
$2 HCl + 2 CuCl \rightarrow 2 CuCl_2 + H_2$		200
$2 CuCl_2 \rightarrow 2 CuCl + Cl_2$		600
° CHROMIUM CHLORIDE PROCESS		
Knoche, Aachen Univ., Juelich, 1972		
$H_2O + Cl_2 \rightarrow 2 HCl + 1/2 O_2$		700°C
$2 HCl + 2 CrCl_2 \rightarrow 2 CrCl_3 + H_2$		200
$2 CrCl_3 \rightarrow 2 CrCl_2 + Cl_2$		800

has been of commercial interest for almost a hundred years and is known as the Deacon process for chlorine manufacture.

The equilibrium in the Deacon reaction can be reversed, i.e., shifted to hydrogen chloride production, merely by increasing the reactor temperature. This reverse Deacon process has been extensively used as a commercial source of hydrogen chloride since the early forties (3-73).

The thermodynamics of the hydrogen chloride-hydrogen-oxygen water system have been widely studied. The reverse Deacon reaction proceeds with a 60 percent conversion of water at 730°C and a 50 percent conversion at 620°C, at atmospheric pressure. It has become a very attractive first step for many water decomposition schemes.

The first such scheme uses vanadium chlorides in a four step cycle and was first reported by Funk and Reinstrom (3-74) in 1964. It has since been reviewed in the literature several times (3-33, 3-34, 3-66). Funk has calculated an overall efficiency of 18 percent higher heating value (HHV) for the process, a figure which is low when compared with other processes of Table 3-11. This may be so because Funk has included the energy required for separation as going through the heat-work transition. The H-T diagram for this process (Figure 3-15) also shows the high price in terms of efficiency when conducting a highly endothermic reaction at high temperature. Several variations of the vanadium chloride process have been proposed. One such variation makes use of the vanadium oxichlorides, as suggested by their lower affinities for water, at the expense of somewhat higher temperatures (3-71). Other chlorides of the Group V family such as tantalum have been considered and found less promising than vanadium (3-74).

The next process in Table 3-7 follows the reverse Deacon reaction with two reactions involving iron chlorides. The temperatures indicated were chosen on thermodynamic grounds. The process has been patented by De Beni (3-68). An interesting variation of this process makes use of the first reaction followed by chlorination of chromium II chloride by hydrogen chloride and a chromium III to chromium II chloride reaction with iron chlorides.

The next process on Table 3-7 is a five step cycle developed by Euratom at Ispra under the name of Mark 7. The cycle follows the reverse Deacon reaction with a chlorination of iron oxide at 120°C. Hydrogen evolves by hydrolysis of ferrous chloride formed on decomposition of ferric chloride. The fifth reaction results in a closed cycle with only water being consumed. Work on the second reaction is presently being carried out at Ispra (3-71). Preliminary reports indicate a ferric oxide

conversion of over 50 percent at 150°C with minimum production of the oxychloride by undesirable side reactions. The third reaction, the ferric-ferrous chloride shift, is well known. The fourth reaction is also under experimental study at Ispra, where over 95 percent conversion has been observed at the reported temperatures. This seems to be one of the most promising processes under study by Marchetti and co-workers. Several variations of this process have been suggested by Hardy (3-72), Knoche and Schubert (3-75), and Wentorf and Hanneman (3-44).

The next alternate process uses cuprous and cupric chlorides in a three step sequence. There is a strong evidence that the second reaction will take place, possibly in two steps with a decomposition of cuprous chloride into copper and cupric chloride and a reaction of the metal with the hydrochloric acid close to room temperature. The third reaction in the process is well known. A somewhat more involved alternative has also been suggested by Wentorf and Hanneman (3-44).

Iron Oxide and Carbon Oxide Processes

Two processes involving carbon and iron oxides have been proposed in the literature. The first one was suggested by Von Fredersdorff at the Institute of Gas Technology in 1959 and is briefly reviewed elsewhere (3-33). The five reactions in the cycle are presented in Table 3-8.

TABLE 3-8
IRON OXIDE AND CARBON OXIDE PROCESSES

° STEAM IRON-CARBON DIOXIDE PROCESS Von Fredersdorff, Institute of Gas Technology, 1969		
Fe + H ₂ O	→ FeO + H ₂	
3 FeO + H ₂ O	→ Fe ₃ O ₄ + H ₂	550 to
Fe ₃ O ₄ + CO	→ 3 FeO + CO ₂	950°C
FeO + CO	→ Fe + CO ₂	
2 CO ₂	→ 2 CO + O ₂	315
° CARBON - STEAM - IRON PROCESS Marchetti and De Beni, Euratom, 1970		
C + H ₂ O	→ CO + H ₂	700°C
CO + 2 Fe ₃ O ₄	→ C + 3 Fe ₂ O ₃	250
3 Fe ₂ O ₃	→ 2 Fe ₃ O ₄ + 1/2 O ₂	1400
° STEAM CARBON PROCESS		
2 H ₂ O + 2 CO	→ 2 CO ₂ + 2 H ₂	400°C
2 CO ₂	→ 2 CO + O ₂	315
O + 2 Hg	→ 2 CO + 2 HgO	450
2 ² HgO	→ 2 Hg + O ₂	600

The reaction sequence differs from conventional steam-iron processes in that for closed cycle production of hydrogen, some means has to be found to decompose carbon dioxide into carbon monoxide for recirculation. Several have been proposed and studied although much research and devel-

opment work is still necessary to increase yields and make this last step economically feasible. Some interesting possibilities are radiolytic decomposition in nuclear reactors, high temperature thermal decomposition, and decomposition in radiation, electrical discharges, or radio frequency arcs.

A second carbon-iron oxide process has been suggested by De Beni and Marchetti (3-69). It is a very straightforward, three reaction scheme but requires a high temperature for the decomposition of the iron oxide. Work at Ispra on this process has not been pursued because of this rather serious shortcoming.

A carbon oxide process somewhat related to the above is also suggested in Table 3-8. The first reaction is known industrially as the water gas shift reaction and for many years has been used in secondary steam reformers for hydrogen production. At the indicated temperature the reaction achieves equilibrium very rapidly over a chromium-nickel catalyst. The second reaction has been discussed in connection with the Institute of Gas Technology process and, as indicated, it still needs developmental work. The third and fourth reactions will separate oxygen and carbon monoxide in the effluent from the carbon dioxide decomposition reactor and could be included also in the scheme suggested for the first process in Table 3-8.

Metal and Alkali Metal Processes

Several processes have been suggested based on the reaction of water with alkali metals to produce hydrogen and metal-oxygen compounds, which are then reduced and recycled. The first such process presented in Table 3-9 was patented by Miller and Jaffe in 1970 (3-76) using cesium and cesium oxides. The second reaction in this cycle has a very poor conversion at equilibrium and the indicated temperature. This results in a considerable expenditure of work for separation and recirculation. The high temperature indicated for the fourth reaction also presents a serious process liability.

The second process in Table 3-9 has recently been suggested by Abraham and Schreiner at Argonne National Laboratory (3-77). The second reaction in the cycle, the thermal decomposition of hydrogen iodide, is well known. At the temperature indicated a 23 percent dissociation will occur. Separation of hydrogen iodide from the mixture can easily be accomplished by thermal means such as distillation. The third reaction, the decomposition of the alkali nitrate to nitrite, is reversible under pressure and has long been known to occur. The first reaction is similar to the well studied oxidation of sulfuric acid by iodine to form the sulfate ion and hydrogen iodide. There is no reason to believe the reaction will not go as

TABLE 3-9
METAL AND ALKALI METAL PROCESSES

° CESIUM OXIDE PROCESS	
Miller and Jaffe, Aerojet General, 1970	
$2 \text{H}_2\text{O} + 2 \text{Cs} \rightarrow 2 \text{CsOH} + \text{H}_2$	100°C
$2 \text{CsOH} + 3/2 \text{O}_2 \rightarrow \text{H}_2\text{O} + 2 \text{CsO}_2$	500
$2 \text{CsO}_2 \rightarrow \text{Cs}_2\text{O} + 3/2 \text{O}_2$	700
$\text{Cs}_2\text{O} \rightarrow 2 \text{Cs} + 1/2 \text{O}_2$	1200
° LITHIUM NITRITE PROCESS	
Abraham and Schreiner, Argonne Nat. Labs., 1973	
$\text{LiNO}_2 + \text{I}_2 + \text{H}_2\text{O} \rightarrow \text{LiNO}_3 + 2 \text{HI}$	25°C
$2 \text{HI} \rightarrow \text{H}_2 + \text{I}_2$	425
$\text{LiNO}_3 \rightarrow \text{LiNO}_2 + 1/2 \text{O}_2$	475
° TIN OXIDE PROCESS	
Souriau, Gaz de France, 1972	
$\text{Sn} + 2 \text{H}_2\text{O} \rightarrow 2 \text{H}_2 + \text{SnO}_2$	400°C
$2 \text{SnO}_2 \rightarrow 2 \text{SnO} + \text{O}_2$	1700
$2 \text{SnO} \rightarrow \text{SnO}_2 + \text{Sn}$	700
° MANGANESE - SODIUM OXIDE PROCESS	
De Beni, Euratom, 1972	
$\text{Mn}_2\text{O}_3 + 4 \text{NaOH} \rightarrow 2\text{NaO} \cdot \text{MnO}_2 + \text{H}_2\text{O} + \text{H}_2$	800°C
$2 \text{NaO} \cdot \text{MnO}_2 + n \text{H}_2\text{O} \rightarrow 4 \text{NaOH (aq.)} + 2 \text{MnO}_2$	100
$2 \text{MnO}_2 \rightarrow \text{Mn}_2\text{O}_3 + 1/2 \text{O}_2$	600

suggested by Abraham and Schreiner. Further details and references to the chemistry of the reactions on this cycle can be found in the original article (3-77).

A metal oxide process suggested by Souriau in 1972 (3-78) is also presented in Table 3-9). The second reaction calls for decomposition of tin IV oxide at fairly high temperatures obtained from a nuclear heat source. Oxygen is separated from the molten oxide mass by quenching at 700°C, at which temperature liquid tin is separated from the oxide. The metal at 400°C is then reacted with steam at 250°C for the production of hydrogen. The authors claim a production of 10⁵ m³ of hydrogen per hour with a thermal input of 840 MW. In an integrated plant, 180 MW of electric power would also be produced, with an overall efficiency of 42 percent (HHV) or 36 percent (LHV). A very serious drawback of this process is the high temperature required for the second step.

The last process on Table 3-9 is based on multiple valence oxygen compounds of manganese and sodium. The first reaction was reported by Williams (3-79) in 1956. De Beni found no reaction under the conditions described by Williams and suggested a modification which would use sodium carbonate instead of the hydroxide (3-71). This conflicting information seems to merit further study.

Finally, Table 3-10 presents several closed cycle processes involving electrolytic steps. In all cases the useful work required would be less than for the electrolysis of water. Of these processes only the first has been extensively studied in the context of Energy Depot Systems by Hallett and coworkers at Air Products (3-71).

An overall view of process conditions for several thermochemical water splitting methods is presented in Table 3-11. Some

TABLE 3-10
CHEMICAL - ELECTROLYTIC PROCESSES

° HYDROGEN CHLORIDE ELECTROLYTIC PROCESS		
Hallett, Air Products, 1965		
H ₂ O + Cl ₂ + 2 HCl + 1/2 O ₂		700°C
2 HCl → H ₂ + Cl ₂	(Electrolysis)	300
° MERCURY CHLORIDE ELECTROLYTIC PROCESS		
H ₂ O + Cl ₂ + 2 HCl + 1/2 O ₂		700°C
2 Hg + 2 HCl → 2 HgCl + H ₂		300
2 HgCl → 2 Hg + Cl ₂	(Electrolysis)	500
° IRON CHLORIDE ELECTROLYTIC PROCESS		
H ₂ O + Cl ₂ + 2 HCl + 1/2 O ₂		700°C
2 HCl + 2 FeCl ₂ + 2 FeCl ₃ + H ₂	(Electrolysis)	200
2 FeCl ₃ + 2 NO + 2 FeCl ₂ + NOCl		175
2 NOCl → 2 NO + Cl ₂		150
° COPPER CHLORIDE ELECTROLYTIC PROCESS		
H ₂ O + Cl ₂ + 2 HCl + 1/2 O ₂		700°C
2 HCl + 2 CuCl → 2 CuCl ₂ + H ₂	(Electrolysis)	200
2 CuCl ₂ → 2 CuCl + Cl ₂		300

comments in regard to efficiencies and reaction temperature levels will be made later in Section 3.5. It is apparent that, even under very optimistic conditions, thermal efficiencies will probably fall short of 50 to 60 percent. Still, this compares very favorably with electrolysis using projected advanced cell technologies.

3.4.3 PHOTOLYSIS OF WATER

Photolysis, derived from the Greek word which translates into "breakdown with light", is the mechanism by which a compound is decomposed using the energy of incident photons. Light absorbed by a molecule raises one of its electrons into an excited energy state, thereby making the electron available for pairing with an electron from a neighboring atom or mole-

cule in an electron-pair bond. By this photochemical process new molecules are formed. The units used in photochemistry as well as the terminology can be found in most scientific encyclopedias (3-80).

The decomposition of a compound molecule requires the breaking of molecular bonds. In the photolysis of water, light provides the necessary energy for the bond breakage. The overall photochemical reaction can be summarized by the reaction,

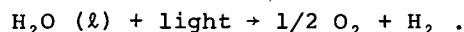

In this process light energy in the amount of 68.3 kcal is absorbed per mole of water decomposed. This energy may be considered to be stored in the reaction products for later use.

TABLE 3-11
PROCESS CONDITIONS FOR SOME WATER DECOMPOSITION PROCESSES

	Cesium Oxide Process	Tin Oxide Process	Vanadium Chloride Process	Calcium Bromide Process	Fe Chloride Oxide Process	HCl Electrolytic Process	Direct Water Electrolysis
° PROCESS HEAT (kcal/gmole H ₂)	125.0	123.6	155.0	88.3	66.0	13.8	nil
° PUMPING/SEPARATION WORK (kWh/lb H ₂)	1.32	0.90	18.2	2.1	NA	3.6	--
° WASTE HEAT (kcal/gmole H ₂)	12.5	34.5	161.0	4.5	63.5	121.5	177.0
° ELECTRICAL WORK INPUT (kWh/lb H ₂)	--	--	--	--	--	15.3	20.0
° TOTAL ENERGY INPUT (kcal/gmole H ₂)	142.5	161.5	385.0	114.0	129.5	206.8	253.0
° THERMAL EFFICIENCY							
(HHV)	48 %	42 %	18 %	59 %	53 %	33 %	27 %
(LHV)	41 %	36 %	15 %	49 %	45 %	28 %	23 %
° HIGHEST ENDOTHERMIC REACTOR TEMPERATURE, (°C)	1050	1700	725	730	800	816	120
° FRACTION OF PROCESS HEAT AT HIGHEST TEMPERATURE	70 %	90 %	30 %	26 %	32 %	7 %	--
° REACTIONS IN CLOSED CYCLE	4	3	4	4	5	2	1
° H ₂ DELIVERY PRESURE, (Atm.)	(1)	(1)	(1)	15	1	19	20

Heat to Work Efficiency: 30 % whenever applicable

NA: Not Available

1 kcal/gmole H₂ = 0.264 kWh/lb H₂

Because water is transparent to visible light, it can only be photolyzed with visible light by the use of photocatalysts. The primary function of such a photocatalyst is to absorb the incident light energy. High absorptivity together with a broad spectral response are the most important factors in selecting these photosensitizers. Including the photocatalyst in the reaction mechanism results in the following half-reactions,

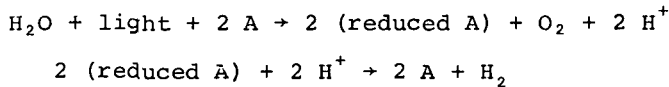

It is important to note that the photocatalyst (A) is not consumed, but is regenerated and available for reuse indefinitely. Three types of photocatalysts have been found;

- compound salts,
- compound semiconductors,
- photosynthetic dyes.

Figure 3-16 displays the energy path of the photocatalytic dissociation of water. With all three types of catalysts the reactions which occur are oxidation-reduction reactions. This energy path is discussed in more detail in Section 3.5.1.3.

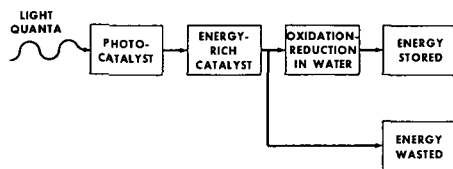
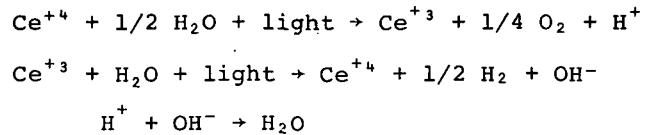

FIGURE 3-16
ENERGY PATH OF PHOTOLYSIS

3.4.3.1 COMPOUND SALT CATALYSTS

In the photocatalytic decomposition of water, the photocatalyst just oxidizes and then reduces water, and is itself reduced and then oxidized. Illuminated solutions of ceric ions, for example, oxidize water and liberate oxygen, while illuminated solutions of ceron-ions reduce water and liberate hydrogen (3-81). In both cases, light energy moves the system from the more stable to a less stable energy-rich state. The light energy is converted into chemical energy without the loss of any of the cerium or acid employed in the process.

The reactions, which occur with light of 2536Å wavelength (near ultraviolet), are the following,



The net result (i.e. the sum) of these reactions is the decomposition of water. Other undesirable side reactions result in the degradation of incident light energy into wasted heat.

The first reaction can also occur thermally at a measurable rate above 30°C (3-82) to generate oxygen. Using this, a photolysis cell has been proposed (3-83) by which water may be decomposed into hydrogen and oxygen in separate compartments. This is illustrated in Figure 3-17. The

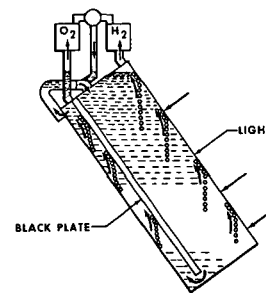

FIGURE 3-17
PHOTOLYSIS CELL

longer wave length light of incident radiation passes through the hydrogen compartment and is absorbed by the back plate, thus heating the solution in the oxygen compartment behind the plate. In this compartment the first reaction occurs, generating oxygen. The shorter wave length (UV) light is absorbed by cerous ions (in the hydrogen compartment) which are converted into ceric ions with the liberation of hydrogen (3-88).

3.4.3.2 COMPOUND SEMICONDUCTOR CATALYSTS

Compound semiconductors may be used in a photolysis cell, such as depicted in Figure 3-18, to electrochemically photolyze

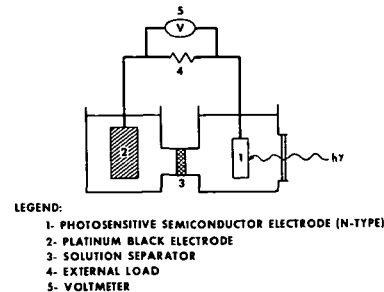
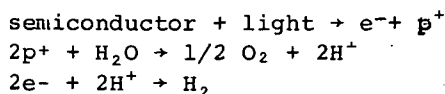

FIGURE 3-18
PHOTO-ELECTROCHEMICAL CELL

water to hydrogen and oxygen (3-84). Light absorbed by the semiconductor electrode excites its electrons and results in a redistribution of energy and the creation of free electrons and "holes". It is then possible to utilize a fraction of the accumulated electrons and holes for the decomposition of water by the following reactions,



The second reaction occurs at the semiconductor electrode and the third at the platinum electrode. This method is analogous to electrolysis by application of a voltage to the cell, except that in this case the voltage required is generated by light absorption. More detailed treatment of this method is given elsewhere (3-84, 3-85).

3.4.3.3 PHOTOSYNTHETIC DYES

It is generally accepted that in photosynthesis two interacting light systems cooperate to convert and store solar energy for the maintenance of plant life (3-28, 3-86). Light absorbed in this manner by blue-green algae can create voltages sufficient to electrolyze water to hydrogen.

Research is being initiated at Case Western Reserve University on the "bio-photolysis" of water to hydrogen and oxygen

by coupling the activity of the bacterial enzyme, hydrogenase, with the reducing power created by the photosynthetic apparatus (3-87). These methods of producing hydrogen from water are assessed in Section 3.5.1.3.

3.4.4 DIRECT THERMAL SPLITTING OF WATER

Water may be decomposed directly by raising it to high temperatures. The theoretical equilibrium conversion to hydrogen and oxygen for this process is quite low, except at extremely high temperatures (in excess of 2000°K). This may be seen by reference to Table 3-12 which gives the equilibrium constant, water conversion, and mole fraction of hydrogen produced as a function of total pressure and temperature. Two observations can be made from this table:

- As the pressure is reduced, the equilibrium conversion is increased, thus lower operating pressures favor increased conversions. This can also be intuitively deduced from Le Chatlier's Principle for a reaction in which the net number of moles is increased. The same results also apply for reduced water partial pressures. One proposed method of operation is to use normal pressures (1 atm.) and an

TABLE 3-12
THERMAL SPLITTING EQUILIBRIUM DATA FOR WATER

Pressure (atm)	Temperature (°K)	K_a	K_y	Water Conversion	Mole Fraction of H ₂
0.1	1000	6.75×10^{-10}	2.13×10^{-9}	2.09×10^{-6}	2.09×10^{-6}
0.1	2000	3.57×10^{-3}	1.13×10^{-2}	7.67×10^{-2}	7.39×10^{-2}
0.1	3000	6.84×10^{-1}	2.16	1.0	6.67×10^{-1}
0.1	4000	9.53	3.01×10^1	1.0	6.67×10^{-1}
1.0	1000	6.75×10^{-10}	6.75×10^{-10}	1.21×10^{-6}	1.21×10^{-6}
1.0	2000	3.57×10^{-3}	3.57×10^{-3}	3.64×10^{-2}	3.58×10^{-2}
1.0	3000	6.84×10^{-1}	6.84×10^{-1}	9.55×10^{-1}	6.46×10^{-1}
1.0	4000	9.53	9.53	1.0	6.67×10^{-1}
10.0	1000	6.75×10^{-10}	2.13×10^{-10}	6.14×10^{-7}	6.14×10^{-7}
10.0	2000	3.57×10^{-3}	1.13×10^{-3}	1.71×10^{-2}	1.70×10^{-2}
10.0	3000	6.84×10^{-1}	2.16×10^{-1}	4.23×10^{-1}	3.49×10^{-1}
10.0	4000	9.53	3.01	1.0	6.67×10^{-1}

inert diluent such as helium to obtain a low water partial pressure in the reaction system; and

- The equilibrium yield increases with increasing temperature. It appears that in a closed reaction system, a temperature of at least 2000°K is required even at moderate pressures (0.1 atm.) for small conversions.

It is well to note that all reactions other than the simple dissociation of water to hydrogen and oxygen have been neglected. At the elevated temperatures required for this reaction, the dissociation of molecular hydrogen and oxygen to atomic hydrogen and oxygen, and possibly other, more complicated, side reactions may be quite significant and can exert a controlling effect on the equilibrium behavior.

It may be possible to obtain hydrogen at temperatures significantly below 2000°K in an open (non-equilibrium) reaction system if the reaction products, hydrogen and oxygen, are continuously removed from the system as shown in Figure 3-19. This may

rate with manageable diffusing areas. To date palladium and palladium based alloys, both expensive and difficult to fabricate, are the only materials known to allow the passage of hydrogen. Finally, the pressure at which the hydrogen is produced is a very important economic factor in the cost of hydrogen production. At low pressures where direct splitting is favored, large pumping costs are incurred in delivering large volumes of hydrogen gas to a transmission system at pipeline pressure, typically 50 atm (750 psia). This pumping cost must be considered in comparing processes for producing hydrogen since, other factors being equivalent, a high pressure process will be economically favored in a tradeoff study.

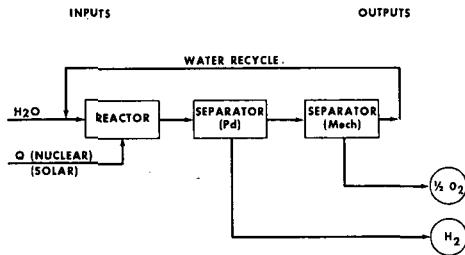

FIGURE 3-19
NON-EQUILIBRIUM THERMAL SPLITTING

be accomplished by use of a perm-selective membrane such as palladium. This approach is presently being investigated by the Johnson Space Center of NASA (3-88) and is showing some promise.

For commercial feasibility the method of direct thermal splitting of water may be impractical for a variety of reasons, although schemes have recently been proposed (3-89) to make this process operable. Either high temperatures and low operating pressures (or partial pressures) must be combined for a reasonable yield (this implies a high temperature energy source which is presently unavailable), or, using the NASA concept, a materials problem is encountered in the selection and manufacture of suitable separation membranes capable of withstanding high temperatures and diffusing hydrogen at an adequate

3.5 CONVERSION PATHS

3.5.1 SOLAR ENERGY PATHS

There are a number of ways to produce hydrogen, using solar energy as the primary energy source. The question that must be considered is what is the best way to produce hydrogen from solar energy? By best way we mean that method which delivers hydrogen to the user at the lowest cost.

Present concepts of solar energy collection include both terrestrial and space operations. The idea of orbiting solar collectors in space has been proposed by Glaser (3-90, 3-91). The advantages of solar energy collection in space have been well summarized as (3-14):

A satellite in synchronous orbit around the earth's equator receives solar energy for 24 hours a day, except for brief periods around the equinoxes. In this orbit, a satellite receives six to ten times the amount of solar energy available in suitable terrestrial locations in the United States.

In this concept, a 10,000 MW station would require 16 square kilometers of collector surface (3-14). Energy would be sent to the earth by microwave transmission.

The major problem presented by solar energy utilization in space is the lack of the required technology. It is not presently possible to deploy or fabricate solar collectors in space that have dimensions of several kilometers on each side. The present lack of technology makes economic forecasting very difficult. Ford and Kane (3-89) have pointed out that the land area required for the microwave receivers is about the same as the land area required for terrestrial solar energy collection. This method may have good potential for power generation in the future, however a great deal of research and engineering remains to be done before the economic feasibility can be well assessed. Solar energy collection in space will not be further considered in this report.

Three paths for producing hydrogen on earth are shown in Figure 3-20. These paths correspond to the solar energy paths in the systems diagram discussed in Section 3.2. We will consider each of these paths, and determine which one supplies hydrogen at the lowest cost.

3.5.1.1 SOLAR-ELECTROLYSIS PATH

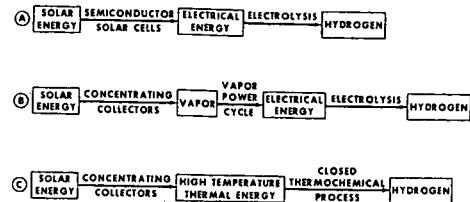

FIGURE 3-20
THREE PATHS FOR PRODUCING
HYDROGEN USING SOLAR ENERGY

Solar Cells

The use of silicon solar cells for generating electrical power in space satellites is well known. It is logical to extend this method to terrestrial power generation, and this has been proposed (3-4, 3-14, 3-92). The major problem at present is the cost of solar cells. Wolf (3-93) estimates that the cost of solar cells must be reduced by a factor between 200 and 3000 in order to compete with present electricity rates. Spakowski and Shure (3-94) reached a similar conclusion, requiring a cost reduction factor between 100 and 1000.

Efficiency Analysis. - Path A of Figure 3-20 is a two step process. The first step is the conversion of solar to electrical energy by means of silicon solar cells. The efficiency of this conversion has a theoretical maximum of 24 percent (3-91). Actual achieved efficiencies are in the neighborhood of 11 percent, while optimistic future (1985) extrapolations predict efficiencies of 19 percent. It seems reasonable to take an average of these; therefore, an efficiency of 15 percent will be used. For the electrolysis step, present efficiencies vary from 57 percent to 70 percent, while efficiencies in the neighborhood of 80 percent are predicted (3-34). Again, an average will be used and the efficiency of electrolysis will be taken as 75 percent. Thus, the overall efficiency of the process is about 11 percent.

In order to compare the three paths of Figure 3-20, a common basis of comparison must be chosen. The basis used will be an output of 1 kilowatt (kW) of hydrogen. This means that if all of the hydrogen produced by the process was burned as fuel, the combustion would liberate heat energy at the rate of 1 kW. For convenience the higher heating value (HHV) of hydrogen is used in

determining the amount of heat liberated. Using this method, the power input and output of each step can be calculated. Figure 3-21 shows that a hydrogen output of 1 kW requires an input of 1.33 kW to the electrolyzer. This, in turn, requires that 8.9 kW of solar power impinge on the solar cells.

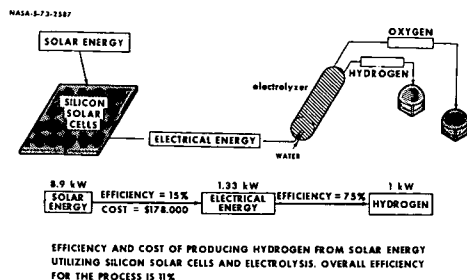

FIGURE 3-21
EFFICIENCY AND COST OF PRODUCING
HYDROGEN FROM SOLAR ENERGY
(SILICON SOLAR CELLS)

Economic Analysis. - As previously stated, solar energy utilization is a capital intensive enterprise. Because of this, only the capital costs required for the three paths shown in Figure 3-20 will be considered. For Path A, the cost of the silicon solar cells and the cost of the electrolysis equipment, per kW of hydrogen out, is required. Wolf (3-87) gives the present cost of silicon solar cells as \$7,000 per square meter. This case requires an input power of 8.9 kW. The basis for calculation is a solar power density of 700 W/m² for 12 hours per day (Arizona desert conditions), or an average of 350 W/m² for 24 hours per day. In order to deliver 8.9 kW from an input density of .35 kW/m², 25.4 square meters of silicon solar cells are needed. The cost of these, at \$7,000 per square meter, is \$178,000. This cost is so astronomical that the cost of the electrolysis equipment, compared to the solar cell investments, can be neglected.

Prognosis. - The present cost of hydrogen production by the process shown in Figure 3-21 is much too high. The combination of low efficiency and high cost make this concept of hydrogen production unattractive. The situation could be changed by major advances in solar cell technology.

Vapor Power Cycle

Path B in Figure 3-20 is similar to Path A, except that a conventional vapor power cycle is used to generate electrical power. The concept is neither new nor

radical (3-95). Figure 3-22 shows the various pertinent quantities for the process.

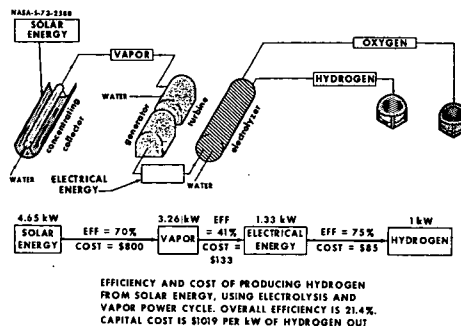

FIGURE 3-22
EFFICIENCY AND COST OF PRODUCING
HYDROGEN FROM SOLAR ENERGY
(VAPOR POWER CYCLE)

Efficiency Analysis. - The first step in the process is solar energy collection using concentrating collectors. The efficiency of a collector is defined as the ratio of the increase in the enthalpy of the steam as it flows through the collector to the solar energy input. The enthalpy change is the solar energy input minus the heat losses. Ford and Kane (3-89) estimate that radiation losses can be kept below 10 percent, when the maximum steam temperature in the collector is 1200°C. The parametric analysis given by Meinel and Meinel (3-96) is considerably less optimistic. They predict losses in the neighborhood of 25 to 30 percent at temperatures in the range of 500 to 600°C. In the interest of realism, we use the 30 percent figure, which yields an efficiency of 70 percent for solar energy collection.

The second step in the process is the vapor power cycle. For a source temperature of 550°C and a heat rejection temperature of 27°C, the Carnot efficiency of the vapor cycle is 63.5 percent. If the actual efficiency is 65 percent of the Carnot efficiency, then the efficiency of the second step of Figure 3-22 is 41.2 percent. The electrolysis step has an efficiency of 75 percent, giving the overall process an efficiency of 21.4 percent.

Economic Analysis. - The energy input and output can be calculated for each step of the process in Figure 3-22. These values, shown in the figure, are based on a final output of 1 kW of hydrogen. It is seen that the solar input is 4.65 kW for 1 kW of hydrogen output.

The cost of each step can also be determined. Since 4.65 kW of solar power must be absorbed, this will require 13.3

square meters of concentrating collectors. Meinel and Meinel (3-11) suggest a cost of \$60 per square meter, while Ford and Kane (3-89) suggest \$33 per square meter. Using the higher figure, the cost of solar energy collection is \$800 per kW of hydrogen. A turbo-generator receives 3.26 kW of steam and delivers 1.33 kW of electric power, at a capital cost of \$100 per kW output. Thus, the turbo-generator cost is \$133 per kW of hydrogen out. The 1.33 kW of electrical power enters the electrolysis plant. The capital cost of the electrolysis plant is \$65 per kW of input (3-38) so that the cost of the electrolysis plant is \$86 per kW of hydrogen out. The capital cost of the process shown in Figure 3-22 is therefore \$1019 per kW of hydrogen out. Most of this cost is for energy collection.

Prognosis. - The capital cost of the equipment required for this process is four or five times that of a conventional fossil fuel plant performing the same function. Although we are not ready to use this process at present, a sharp increase in fossil fuel costs would make the process more attractive. A large decrease in the cost of solar collectors would have the same effect. Eighty percent of the capital investment goes for solar collectors. This is the classical course of solar devices; the low energy density causes a large area requirement which, in turn, causes large capital costs.

3.5.1.2 SOLAR-CLOSED CYCLE THERMOCHEMICAL PATH

Path C in Figure 3-20 is the only one that does not require electrical generation and subsequent electrolysis. In this path, the solar energy is used to produce hydrogen by means of a single intermediate step. The use of closed cycle thermochemical processes for the dissociation of water is discussed in Section 3.4.2.2, where it is shown that a large number of possibilities exist.

Efficiency Analysis. - Figure 3-23 contains the pertinent efficiencies and costs for the process. The first step is solar energy collection, where an efficiency of 70 percent is used. The second step is the thermochemical process. The maximum efficiency of a thermochemical process which dissociates water can be taken as (3-21):

$$\text{Eff}_{\text{process}} = \frac{T_{\text{max}} - T_{\text{reject}}}{T_{\text{max}}} \frac{T_1}{T_1 - T_{\text{reject}}}$$

where T_{max} = maximum absolute temperature of the process

T_{reject} = absolute temperature at which heat is rejected

T_1 = absolute temperature at which water is thermally dissociated (approx. 2500°K)

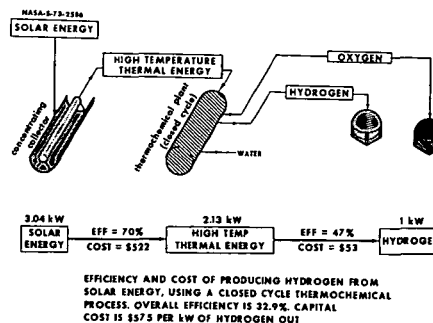

FIGURE 3-23
EFFICIENCY AND COST OF PRODUCING
HYDROGEN FROM SOLAR ENERGY
(CLOSED CYCLE THERMOCHEMICAL)

The quantity $\text{Eff}_{\text{process}}$ is the ratio of the heating value of the hydrogen produced by dissociation to the energy input to the process. If we assume that T_{max} is 550°C and T_{reject} is 27°C, the theoretical efficiency of the process is 72.4 percent. For the vapor power cycle, it was assumed that the actual efficiency was 65 percent of theoretical; the same assumption is used for the thermochemical cycle. Thus, the actual efficiency of the thermochemical cycle is 47 percent. This is the value used by Kerns (3-34) for the Mark 1 process. The overall efficiency of the process is 32.9 percent.

Economic Analysis. - The energy input and output of each step is shown in Figure 3-23. The path requires 3.04 kW of solar power for each kW of hydrogen out. The cost of the solar collectors is \$522, assuming an average solar energy density of .35 kW/m² and a cost of \$60 per square meter for collectors. The cost of the thermochemical process plant is estimated as \$25 per kW of thermal input (3-38), therefore the chemical plant cost is \$53 per kW of hydrogen out. The resulting total cost for this path is \$575 per kW of hydrogen out.

Prognosis. - The capital cost for hydrogen production by closed thermochemical cycles is a little more than half the cost for generating electricity and then electrolyzing water. This would be expected since there are fewer steps in the process. The future of this method rests largely with the development of efficient thermochemical decomposition cycles. The difference

in capital cost between this process and that of Path B is largely due to the differences in the overall efficiencies of the two processes. The more efficient process requires a smaller collector area, and collector cost dominates the economic picture. It can be seen that process efficiency has a large effect on the cost of solar powered hydrogen production.

3.5.1.3 SOLAR-PHOTOLYSIS PATH

In addition to being a diffuse source (as discussed in Section 3.3.1) solar energy reaching earth has inferior spectral qualities for the photolysis of water. Figure 3-24 compares the energy content of light quanta at different wavelengths to the energy needed to break the molecular bonds of water. The solar energy irradiance (3-97) is also shown to indicate which part of the solar spectrum provides reasonable incident energy fluxes. It is clear from this figure that only ultraviolet light has the energy necessary to decompose water directly. However, as seen from the solar irradiance curve, a very small amount of this light actually reaches the surface of the earth. If visible light is to be considered for the photolysis of water, it must involve a stepwise process, with a number of photons contributing their energy for the decomposition reaction. This type of reaction has a small quantum yield. As an example, photosynthesis which proceeds by absorption of blue and red light, is a complicated stepwise process with a small quantum yield.

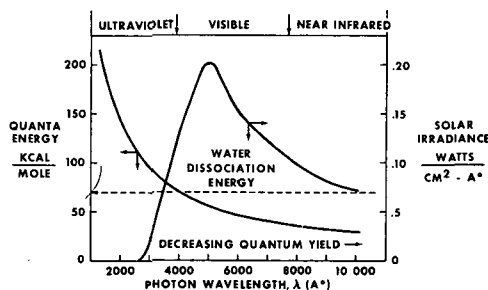

FIGURE 3-24
ENERGY CONTENT OF QUANTA
AND SOLAR IRRADIANCE

For the purpose of assessing photolysis as an energy conversion process it is useful to examine the overall energy path in some detail. Figure 3-25 shows the energy path for photolysis of water using visible light. Absorption of light energy is an important factor in the overall assessment.

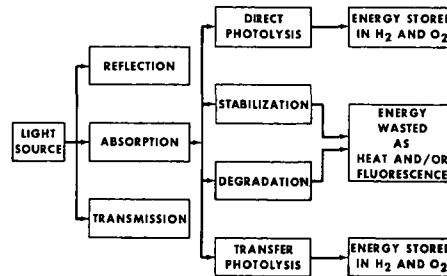

FIGURE 3-25
DETAILED ENERGY PATH FOR
PHOTOLYSIS OF WATER

The fate of absorbed energy is described in detail elsewhere (3-98). For this discussion we will briefly describe the processes which compete with photolysis for the absorbed energy and thereby reduce the efficiency. In this regard, the net quantum efficiency is a measure of how effectively photolysis competes with these other processes for the absorbed energy. With reference to Figure 3-25, both direct photolysis and transfer photolysis ultimately result in the storage of absorbed light energy in the new chemical bonds of molecular hydrogen and oxygen. The only difference is that in direct utilization, the absorbed energy causes the chemical change directly, whereas in transfer photolysis a photosensitizer is involved in the mechanism. As noted earlier, direct photolysis of water with visible light is rare.

Stabilization means that the absorbed energy is held for later use. Eventually the energy is wasted as heat and/or fluorescence. Degradation of the excitation energy is by far the most common event. Partly because there are so many vibrational and rotational modes associated with each electronic excited state, it often happens that an excited molecule in collision with another molecule will convert some of its energy into translation, vibration, or rotation of the other molecule. In this manner a great deal of the energy is degraded to heat.

In general, based on the progress reported in the literature to date, photolysis, using compound salt sensitizers (Section 3.4.3), as an energy storing process, is not feasible for the following reasons:

- Only a small fraction of the already highly diffused solar spectrum is utilized and ultimately stored in the decomposition products. This is manifested either in low yields, low photon absorption, or in a combination

of the two. An investigation of various proposed salt photocatalysts to improve this situation was fruitless (3-99). Because of the very low efficiencies, the economics are poor, and

- Artificial ultra-violet sources are prohibitively expensive because of a very small conversion efficiency. Only in situations where the energy is wasted anyway, can it be justified to convert thermal or electrical energy to light energy, and even then it is highly questionable whether the production of hydrogen by photolysis would be competitive with more conventional hydrogen generating methods.

For the electrolytic decomposition of water, using light absorbing semiconductor, a potential difference of more than 1.23 volts is necessary between the anode and cathode. This potential difference is equivalent to the energy of radiation with a wavelength of approximately 10,000 Å which is well within the infrared portion of the solar spectrum (see Figure 3-24). It is possible, therefore, to decompose water with visible light using this approach. Fujishima and Honda (3-84) have experimentally demonstrated this method using a Xenon lamp to simulate solar light. Most of the energy was delivered at 4150 Å. Their semiconductor was n-type titanium dioxide. Further work on this process should be directed at improving the cell efficiency while significantly reducing their cost.

It is difficult at this stage to assess the biophotolysis approach to water decomposition. It does have the advantage of using a rather wide spectral range, approximately 30 percent of incident radiation. This is much wider than any of the other photolytic methods mentioned.

It should be emphasized that all the photolytic methods of water decomposition discussed are in the research stage. Should one (or more) of them prove feasible it will probably not be available until the late-middle or long time range. None can be considered to be a short term answer.

3.5.2 WIND-ELECTROLYSIS PATH

Since wind energy is available as shaft power, the most reasonable route for the production of hydrogen from wind energy is through the electrical-electrolysis path (Figure 3-1). The economical development of wind energy is therefore tied to the continued development of the electrolysis process. In order to be consistent with previous cost estimates,

the values for electrolysis cost and efficiency are taken from the previously referenced GE-TEMPO Report (3-38).

At this stage, estimates of the cost of large-scale wind power systems are speculative. Based upon the costs of previously built units in the United States, costs of recent European designs, and costs of similar capital machinery, the costs of wind units can be approximated. Table 3-13 presents both a high and low estimate of system capital costs. In a comprehensive analysis of a large system of wind generators, Heronemus (3-100) shows that operating and maintenance costs, and transmission and storage costs are small compared to the cost of the wind units themselves. Thus, the capital costs represent essentially the whole cost of the system.

Two system parameters characterize the optimistic and pessimistic estimates, the capital cost (\$/kWh) of wind turbines, and the productivity of each installation. The range of capital cost of the turbine units is representative of the range reported in the cited literature. It is difficult to improve the accuracy of this estimate until demonstration units are built. Two values are assumed for productivity, 55 and 33 percent. Efficient aerodynamic design, favorable wind patterns, and accurate control systems would all contribute to the higher productivity. As more sites are developed, improved wind pattern analysis (perhaps by satellite surveillance) and improved wind turbine technology will be needed to maintain high productivity.

Two important characteristics of large wind power systems need to be stressed. The wind turbine units must be large, and they must be numerous. In a system designed by Heronemus to be placed off-shore of New England, three wind turbines are set on a single tower such that the individual wind turbines are from 120 to 440 feet above the base (the ocean surface in this case). Each turbine is 200 feet in diameter. It is economically advantageous to have the turbines high above the surface so that they are not exposed to the retarded wind near the surface. It requires 13,695 of these wind turbine arrays to produce 310×10^9 kWh of hydrogen per year. This large number of turbines would result in economics of mass production, tending to lower total systems cost.

3.5.3 FOSSIL ENERGY PATHS

3.5.3.1 FOSSIL-ELECTROLYSIS PATH

The path termed "Fossil-Electrolysis" would require fossil fuel, either coal, petroleum liquids, or natural gas to be burned for the heat of combustion value. The heat would then be used, in a Rankine

TABLE 3-13
HYDROGEN PRODUCTION FROM WIND POWER
BY ELECTROLYSIS OF WATER, 1977-2020

(Two Entries Indicate Optimistic/Pessimistic Estimates)

	<u>1977</u>	<u>1980</u>	<u>1985</u>	<u>1990</u>	<u>2000</u>	<u>2020</u>
Capital cost of wind turbine, \$/kW (max)	150/250	150/250	150/250	150/250	150/250	150/250
Electrolysis: efficiency (7 percent)	66	70	75	80	80	80
\$/kW of input	\$80	\$65	\$50	\$45	\$40	\$40
Capital cost of turbine and electrolyser, \$/kW of H ₂ out (max)	358/500	307/450	267/400	244/369	238/363	238/363
Average productivity of wind system (%)	55/33	55/33	55/33	55/33	55/33	55/33
Capital cost, \$/kW average H ₂ out	634/1515	558/1364	485/1212	443/1117	432/1098	432/1098

cycle to obtain useful work, probably in the form of electricity. In turn the electricity would be used to power electrolytic cells for decomposing water to hydrogen and oxygen. This path is presently deemed impractical for a number of technical and environmental reasons:

- If hydrogen is the main product of the process starting from fossil fuel, a direct conversion from fossil fuel to hydrogen using steam would be more economical, as well as result in a higher thermal conversion efficiency.
- Combustion products from burning fossil fuels are nitrogen oxides, particulates and possibly some carbon monoxide. These pollutants would be lessened in the open-cycle conversion process.
- Processes employing the Rankine cycle are limited in efficiency by the Second Law of Thermodynamics. Currently Rankine efficiencies for fossil fired steam generators are in the range of 35 to 40 percent. The remainder of the energy is rejected as waste heat giving rise to thermal pollution. This problem is currently being faced by electric utilities in planning and siting electric generating plants. Similar problems would be faced by a plant employing the "Fossil-Electrolysis" process.

In conclusion, fossil-electrolysis processes are impractical for hydrogen production

both now and in the long term.

3.5.3.2 FOSSIL-OPEN CYCLE THERMOCHEMICAL PATH

The open cycle thermochemical path for utilizing the fossil primary source is in essence the second approach for using fossil reserves in a hydrogen economy, as discussed in Section 3.4.2.1. Process heat for producing hydrogen from coal can be provided by burning a portion of the coal. Primary process heat requirements are the generation of process steam and supplying any net reaction endothermicity in the gasification process. Process thermal efficiency is very dependent on the extent to which coal has to be used for these functions. For this reason the processes which generate hydrogen from coal (which require steam and are endothermic overall) have appreciably lower thermal efficiencies than processes which produce methane by direct methanation (which have comparably lower steam requirements and are exothermic). This is illustrated by the thermal efficiency being directly related to the carbon efficiency. Wen, et al (3-56) illustrate this with the eleven alternative processes they consider. Their estimated thermal efficiencies range from 46.4 percent for a process which converts coal to hydrogen and carbon monoxide and then catalytically shifts this mixture to methane, to 77.8 percent for a process that involves direct gasification of raw coal to methane. The corresponding carbon efficiencies (ratio of the amount of carbon in the fuel to the total amount of carbon consumed) for these processes are 26.8

percent and 43.5 percent. These processes also correspond respectively to the most and least expensive alternatives.

Another factor to be considered in comparing processes to produce hydrogen or methane from coal is the pressure required. Since the product gas (whether it be hydrogen or methane) is desired at a pipeline pressure of about 50 atm (750 psia), a process which can operate near this pressure with high yields of gas will have a decided economic advantage. As pointed out in Section 3.4.2.1, gasification to methane is favored by high pressures.

The following factors favor producing methane rather than hydrogen from coal:

- higher thermal efficiency
- higher carbon efficiency
- less water required
- high pressure process
- production costs in \$1.00 to \$1.50/10⁶ Btu range for both
- fuel is familiar and does not require changeover.

It is our feeling that coal will not be used as an entry into a hydrogen economy, except perhaps on a demonstration basis or as an interim measure during a transition into a hydrogen economy which will, most likely, be based on nuclear or solar primary energy technology.

3.5.4 NUCLEAR ENERGY PATHS

3.5.4.1 NUCLEAR-ELECTROLYSIS PATH

A possible path leading to the production of hydrogen uses nuclear energy as the basic energy source, followed by electrolysis (as shown in Figure 3-26). Electrolysis plants have been extensively discussed in Section 3.4.1 and nuclear power in Section 3.3.4. The combination nuclear power-electrolysis path has been discussed by several authors (3-32, 3-33, 3-40).

Electrolysis plants require direct current electricity to dissociate water into hydrogen and oxygen. From an energy input viewpoint, these plants depend on the cost of the electric energy supplied at low voltages.

Electrolysis plants are presently used in areas where electricity is inexpensive. Improved electrolyzer technology (operation at higher temperatures and pressures than normally encountered) can lead to higher performance and lower costs. This technology results in higher efficiencies, reflected in lower operating costs and higher current densities, and

gives rise to lower capital costs. These improvements, however, must be coupled with higher fossil fuel costs for the nuclear-electrolysis concept to compete economically with direct open cycle fossil fuel methods of producing fuel gas (Section 3.5.3.2).

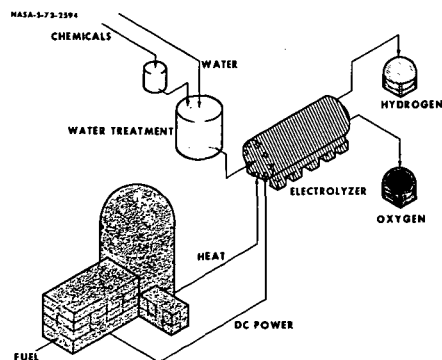

FIGURE 3-26
NUCLEAR-ELECTROLYSIS PLANT

For a nuclear power plant, thermal energy must be converted first to electrical energy, using a conventional turbine-generator arrangement. In addition, ac to dc conversion must be employed for the portion of power used for electrolysis. These steps lead to energy conversion inefficiencies. Significant development efforts are going on in acyclic generators, known as homopolar generators, which will produce direct current electricity at low voltages and high currents. This generator may offer significant capital cost savings over the ac conversion approach.

Despite these improvements, electrolysis to produce hydrogen may be less economical than the nuclear heat - thermochemical water decomposition process, both on a capital cost and efficiency basis. The thermochemical closed-cycle water decomposition process, currently under intensive research and development, promises high thermal efficiencies in converting heat to chemical energy stored as hydrogen.

The siting of nuclear plants and electrolysis plants has been given considerable thought. The nuplex system, an integrated energy system, has been presented in various publications from the Oak Ridge National Laboratory (ORNL) (3-43). These plants would either be located offshore or close to shore. Close proximity to deep water is needed for availability of large quantities of cooling water for reject heat purposes and to supply input water for electrolysis. Part of the reject heat would be used in the desalinization of sea water to provide input distilled

water for electrolysis. In essence, a free supply of heat is available for desalting purposes, but equipment costs, as well as operation and maintenance costs, would have to be considered in any systems evaluation. This has been done in Section 3.6. To supply hydrogen at pipeline pressures of approximately 50 atm (750 psia) it has been proposed that the electrolysis cells be pressurized by maintaining them beneath the sea and using the hydrostatic head of the sea water to obtain the required pressure. A depth of about 1500 feet would be necessary. A full economic study of this proposal has not been attempted. It is felt that the overall economic picture would not be much changed.

3.5.4.2 NUCLEAR - OPEN CYCLE THERMOCHEMICAL PATH

Process heat for coal gasification can be provided by external sources, rather than by burning additional coal for this purpose, as discussed in Section 3.5.3.2. As an example of this approach, Quode (3-101) suggests that heat from the coolant of a high-temperature gas-cooled nuclear reactor (HTGR), which would be available at temperatures near 750°C, be used for this purpose.

In a hydrogen economy, a more likely occurrence would be the use of HTGR heat in conjunction with some means of water splitting (such as the closed cycle processes discussed in Section 3.4.2.2. This would conserve the coal resource for non-fuel uses, such as for chemical feedstocks. These water splitting processes may prove commercially feasible by the time, or shortly after, HTGR reactors are expected to be available in quantity, possibly by 1985.

3.5.4.3 NUCLEAR - CLOSED CYCLE THERMOCHEMICAL PATH

Most of the current thinking on thermochemical closed cycle paths is geared to coupling these processes with a nuclear reactor as a heat source. De Beni and Marchetti (3-70, 3-71) have presented some calculations using helium as a heat transfer medium exiting the nuclear reactor at 1120°K. Funk (3-66) has also considered nuclear sources and has discussed two temperature levels on the heat carrier gas, 1100°K and 1400°K. Miller and Jaffe (3-76), as well as Souriau (3-78) suggest in their patent memoranda the use of nuclear heat. Hallett (3-41) has also studied the hydrogen chloride electrolytic process in the context of a nuclear reactor heat source.

A recent study by Leeth (3-21) suggests

that useful thermochemical water splitting plants would require nuclear reactors capable of supplying steam or helium as heat transfer media at temperatures of 1100°K or higher. This would exclude liquid metal fast breeder reactors unless further development of fuel elements is undertaken. Two types of advanced nuclear reactors will thus be available, the pebble bed reactor, under development in Germany, and the high temperature gas cooled reactor, under study in the United States.

Estimates of nuclear heat costs for these two reactors, when commercially available, are in the neighborhood of \$15.00 per thermal kilowatt. Based on this figure, the plants producing hydrogen via thermochemical processes will have to be built for about \$20.00 per kilowatt in order to be competitive with projected costs for other hydrogen sources. This capital investment figure compares favorably with present costs of \$10.00 per kilowatt for conventional steam reforming plants. The latter have operating costs which are quite sensitive to the fossil fuel supply and demand picture.

3.5.4.4 NUCLEAR - PHOTOLYSIS PATH

It has been suggested that plasma energy, which may leak from a nuclear fusion containment vessel, could be used together with high-mass elements to generate ultra-violet light sources. These sources would then photolyze water vapor to recover the plasma energy as chemical energy in the bonds of molecular hydrogen (3-102). To date, neither nuclear fusion reactors nor hydrogen production by photolysis are technically realizable. Assuming technical feasibility, it is still questionable whether the overall energy efficiency to produce hydrogen by direct photolysis using a fusion reactor would be competitive with other, more conventional, alternatives. The calculations reported do not include the energy needed to bring the pressure of the hydrogen produced by photolysis from 0.03 to pipeline pressure. In addition, the efficiency used by Eastlund and Gough to convert ultra-violet energy into hydrogen fuel is in error by two orders of magnitude.

Excluding the fusion reactor as the primary energy source, there appears no practical way of converting forms of energy into light energy with reasonable efficiency.

3.6 SYSTEM ALTERNATIVES FOR HYDROGEN PRODUCTION

We have reviewed several paths for hydrogen production. At this point, it is desirable to consider the most promising of these paths as system alternatives and to examine them in more detail primarily

from the viewpoint of future energy projections and costs.

The years 1975, 2000 and 2020 were chosen to represent the near short-term, the short-term, the middle-term, and the long-term in this context. The years 1980 and 1990 were added to avoid needless interpolation. A reasonable comparison of system alternatives requires certain bases to avoid disagreement and to achieve some consistency. All cost estimates were expressed in 1972 dollars to avoid inflation judgments and to conform with the program's NASA-ASEE Work Statement. Costs are expressed in dollars per million Btu ($\$/10^6$ Btu) to conform with accepted practice in the energy business and electricity costs are expressed in mills per kilowatt hour for the same reason.

The methodology of obtaining the cost estimates involves estimating capital and operating costs and combining them with a fixed charge rate to obtain the cost of hydrogen on a million Btu basis. Storage, transportation, and distribution costs were left out of the systems study (see Chapter 4).

A computer program was written using IBM's Continuous System Modeling Program (CSMP) language to obtain the costs of producing hydrogen from various cost estimates of the primary energy source. Fixed charge rates of 10, 15, and 20 percent were used in the program. Results for all of the alternatives considered were obtained as yearly intervals from 1972 to 2020 wherever applicable.

Five system alternatives were chosen for this part of the overall systems analysis as the most promising from an achievable viewpoint over the yearly reference frame. These alternatives, available with current technology, are thought to be achievable with adequate research and development investment in the future. The five alternatives chosen are listed below (not in order of importance):

- Nuclear power - electrolysis (from present)
- Nuclear heat - thermochemical decomposition (from 1985)
- Solar heat - thermal decomposition (from 1985)
- Wind - electrolysis (from 1985)
- Coal gasification (from 1975).

3.6.1 NUCLEAR POWER - ELECTROLYSIS

This alternative uses nuclear power plants as the primary energy source, and electrolysis plants to produce hydrogen. The electrolysis plant is located at the same site as the nuclear power plant.

We have considered the cost of input water as well as operation, maintenance, and fuel costs for both plants where applicable. The best available nuclear plant is used each year, the light water reactor (LWR) first, followed by breeder reactors (LMFBR) in later years. Siting is probably on the sea coast or offshore for dissipation of the rejected heat from the reactor. The hydrogen produced is delivered to the pipeline at 750 psia or approximately 50 atm pressure.

Byproducts oxygen and heavy water from the electrolysis process have not been taken into account in the study. In the future, it may prove economical to pipe oxygen parallel to hydrogen and burn them at the point of distribution for electrical generation at high efficiencies.

A reasonable estimate of the capital costs per kilowatt for the reactor installation is taken to be (in 1972 dollars) \$300 per kW in 1972 increasing to \$330 per kW in 2020. These estimates are based on future trends projected by the study team from information received through industrial sources, the trade literature, and personal communication. It is expected that by the year 2000, these costs may be affected by two trends; first, larger plants may make possible the reduction of capital costs by some 10 to 20 percent, and second, current difficulties in site location and approval may increase costs by delays; and additional safety precautions may be added (estimated as \$100/kW today) to escalate costs. On the basis of these costs, another cost estimate deemed 'pessimistic' was prepared with costs ranging from \$450 per kW now to \$546 in 2020.

Estimates of electrolysis plant costs and efficiency based on current technology vary widely. In addition, there are the claims of researchers involved in advanced electrolyzer technology discussed previously. Reductions in cost with time can come from several sources, such as higher current densities, improved efficiencies and cheaper materials. Our estimates follow closely those obtained by GE-TEMPO (3-38) for electrolysis. The major costs of this alternative are given below for the time frame 1972 to 2000.

Option	Plant Costs ($\$/kW$)					
	1972	1975	1985	1990	2000	2020
Nuclear Power						
Optimistic	300	310	320	325	330	330
Pessimistic	450	456	476	486	504	546
Electrolysis	200	100	50	45	40	40

Hydrogen Cost (\$/10⁶ Btu)

Option	1972	1975	1985	1990	2000	2020
Nuclear-Electrolysis						
Optimistic	4.60	3.86	2.46	2.28	2.20	2.17
Pessimistic	6.28	5.48	3.92	3.78	3.69	3.62

Two conclusions can be drawn from these results, first, the cost of electrolytic hydrogen is fairly high even with the optimistic cost picture envisioned, and second, it will stay above the \$2.00 per million Btu figure despite advancing technology.

In fairness, costs that are somewhat more optimistic than ours, quoted by other authors, are presented as well. These (Table 3-14) are based on projected lower costs of obtaining electricity from nuclear reactors.

In general, there seems to be a consensus that hydrogen costs will run about \$2.00/10⁶ Btu or more, provided that electricity costs are 7 mills per kWh or above. Indications are that future electricity costs at much below this price are unrealistic.

3.6.2 NUCLEAR HEAT - THERMOCHEMICAL DECOMPOSITION

This alternative is similar to the first in that a nuclear reactor is used.

TABLE 3-14
REPORTED COSTS OF HYDROGEN OBTAINED VIA ELECTROLYSIS

Cost of Hydrogen (\$/10 ⁶ Btu)	Cost of Electricity (mills/kWh)	Author Cited	Year	Reference	Remarks
1.50	4.0	Gregory (IGT)	1972	3-33	
2.50	7.0	Gregory (IGT)	1972	3-33	
2.95	9.1	Gregory (IGT)	1972	3-33	Lower Cost Range
3.23	9.1	Gregory (IGT)	1972	3-33	Upper Cost Range
1.03	2.5	Mrochek (ORNL)	1969	3-30	
1.39	2.5	Hallett (Air Products)	1968	3-41	
1.79	5.0	Fickett (GE)	1973	3-32	In year 1985
1.35	5.0	Fickett (GE)			In year 2000
3.68	8.0	Michel (AEC Synthetic Fuels Panel)	1972	3-44	
2.33	8.0	Michel (AEC Synthetic Fuels Panel)			Advanced Technology
1.74	8.0	Michel (AEC Synthetic Fuels Panel)			Advanced technology and byproduct credits
1.95	2.5	Michel (AEC Synthetic Fuels Panel)			Advanced technology and off peak power
2.39		Hausz, (GE-TEMPO)	1972	3-38	Year 1977
1.66		Hausz, (GE-TEMPO)			Year 2000

Less capital is required because the thermal-to-electrical energy step involving a Rankine cycle has been eliminated. The electrolysis plant, and the steam turbine alternator-rectifier have been replaced by a chemical plant for the production of hydrogen by a stepwise thermal decomposition of water. As stated earlier, these plants do not exist. Plant costs have been based primarily on the published work of C. Marchetti (3-70) of Ispra, Italy. We have included a somewhat more pessimistic picture by increasing the costs of the thermal decomposition step. This process and the extrapolation of these estimates to the year 2020 must be regarded as very speculative at this time, but this process is well worth evaluating due to the potentially high payoff, if the alternative is made to work reliably at high efficiency.

Plant Costs (\$/kW)				
Option	1985	1990	2000	2020
Nuclear Heat				
Optimistic	75	75	75	75
Pessimistic	125	125	125	125

Thermal Decomposition				
Option	1985	1990	2000	2020
Optimistic	25	20	20	15
Pessimistic	50	45	40	25

Hydrogen Cost (\$/10 ⁶ Btu)				
Option	1985	1990	2000	2020
Nuclear Heat & Thermal Decomp.				
Optimistic	1.51	1.21	1.04	.93
Pessimistic	2.35	1.87	1.59	1.33

It is interesting to note the very little spread between the cost figures in this case. The reason is that the above system alternative has relatively low capital costs compared to the other alternatives. This process should be given priority for research and development because of its high promise. This compares favorably with costs estimated for fuel gas from fossil fuel (coal) costs.

3.6.3 SOLAR HEAT - THERMOCHEMICAL DECOMPOSITION

This alternative (Section 3.5.1.2) is identical to the second above except that nuclear plants are replaced by solar collector plants. The costs and efficiencies are based on the Meinel concept and

are judged to be fairly optimistic at this time. In contrast, our systems analysis indicates a slightly more optimistic figure for solar collector costs, but the figures agree closely with those published for the year 2000 and beyond (3-38).

Plant Costs (\$/kW)				
Option	1985	1990	2000	2020
Solar Collectors				
Optimistic	450	330	280	220
Pessimistic	600	400	300	200
Thermal Decomposition	25	20	20	15

Hydrogen Costs (\$/10 ⁶ Btu)				
Option	1985	1990	2000	2020
Solar-Thermal Decomposition				
Optimistic	4.13	3.25	2.88	2.32
Pessimistic	5.55	3.81	2.58	2.16

It may be seen that this route to hydrogen is well worth consideration as an alternative to nuclear-electrolysis by the year 2000 since the costs are similar. The choice of nuclear energy versus solar energy by the year 2000 may well be decided by the social cost framework and environmental characteristics of these two alternative forms of energy.

3.6.4 WIND - ELECTROLYSIS

This alternative (Section 3.5.2) proposes the use of wind generators in areas of the country having records of steady wind at high velocity. Recent work in this area has been performed by Heronemus (3-100) in his wind generator concept. We have two sets of cost estimates for wind power; one optimistic, using the Heronemus data, and the other pessimistic as estimated by our group. The electrolysis costs are included in the figures stated below. Wind power is expected to be feasible by the year 1980. There is a large price difference for hydrogen dependent on the estimates for wind generators. The technology for wind generators has already been fairly well established, and larger generators may save costs with economies of scale. If the optimistic prediction is believed, we have three of our system alternatives for hydrogen within the same cost bracket. They are nuclear-electrolysis, solar-thermal decomposition (technology not yet available), and wind-electrolysis. It may be well to think seriously of wind powered projects, at least at the demonstration stage for hydrogen production.

Plant Costs (\$/kW)

Option	1980	1985	1990	2000	2020
Wind Generators including electrolysis					
Optimistic	560	485	440	430	420
Pessimistic	1365	1215	1115	1100	1050

Hydrogen Costs (\$/10⁶ Btu)

Option	1980	1985	1990	2000	2020
Wind-Electrolysis					
Optimistic	2.80	2.43	2.22	2.17	2.17
Pessimistic	6.84	6.08	5.61	5.51	5.51

3.6.5 COAL GASIFICATION

As shown in Section 3.4.2.1, it is feasible to produce hydrogen from coal on a large scale at costs comparable to the production of conventional fuel gas (methane). This is not a likely prospect, however, because of other factors favoring methane

production. These include higher thermal and carbon efficiencies, lower water requirement, and higher pressure (reducing compression required for storage and distribution) for producing methane. Also important is that methane is familiar, relatively clean burning, and requires no large scale changeover in existing distribution and use systems. The technology for coal gasification to methane will be available by 1975 and will be implemented on a large scale shortly thereafter.

Hydrogen from coal may be produced for use in the chemical process industries, as fuel for power generation, and, on a small scale, to demonstrate the hydrogen economy concept.

3.6.6 COMPARISON OF RESULTS

In conclusion, the results from this section are plotted on Figure 3-27 to give an overall perspective of the cost of hydrogen, expressed as \$/10⁶ Btu by five system alternatives. All alternatives are evaluated using both optimistic and pessimistic projections.

NASA-S-73-2618

HYDROGEN PRODUCTION COST \$/10⁶ BTU

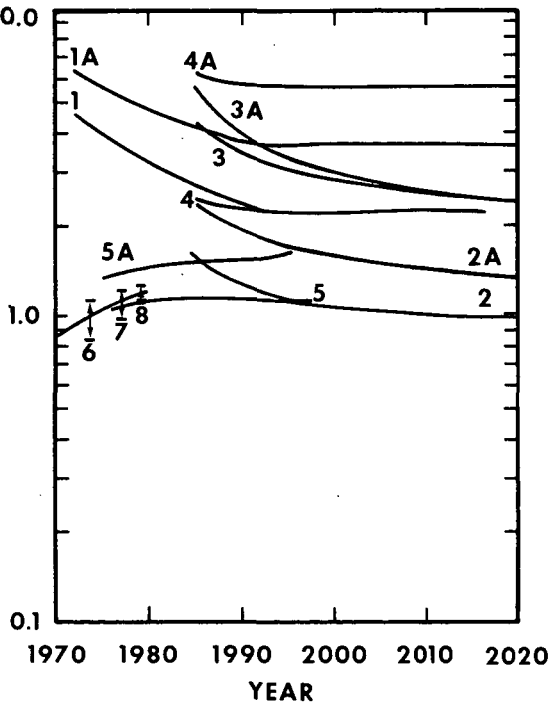

- 1 NUCLEAR-ELECTROLYSIS, OPTIMISTIC
- 1A NUCLEAR-ELECTROLYSIS, PESSIMISTIC
- 2 NUCLEAR HEAT-THERMAL DECOMPOSITION, OPTIMISTIC
- 2A NUCLEAR HEAT-THERMAL DECOMPOSITION, PESSIMISTIC
- 3 SOLAR HEAT-THERMAL DECOMPOSITION, OPTIMISTIC
- 3A SOLAR HEAT-THERMAL DECOMPOSITION, PESSIMISTIC
- 4 WIND - ELECTROLYSIS, OPTIMISTIC
- 4A WIND - ELECTROLYSIS, PESSIMISTIC
- 5 COAL GASIFICATION, OPTIMISTIC
- 5A COAL GASIFICATION, PESSIMISTIC
- 6 IMPORT LIQUID NATURAL GAS
- 7 SYNTHETIC NATURAL GAS
- 8 NATURAL GAS FROM ALASKA

FIGURE 3-27
HYDROGEN COST FOR VARIOUS PATH ALTERNATIVES

It appears that hydrogen will not be produced from coal for a hydrogen economy in the near term. If the technology of thermal decomposition of water is successful by 1985, a hydrogen economy may be ushered in with costs in the \$1.00 to \$1.50/10⁶ Btu range. The other processes considered have a minimum of about \$2.00/10⁶ Btu projected to a high of \$5.00/10⁶ Btu depending on which estimate is used for calculation. These processes of nuclear-electrolysis, solar-thermal decomposition, and wind-electrolysis all have the potential of supplying hydrogen at \$2.00 to \$3.00/10⁶ Btu by the year 2000 to 2020. It is envisioned that no single process will supply all the country's needs for hydrogen in the future. Local conditions of the availability of these various primary energy sources will determine the system alternative to be used in each case.

SELECTED REFERENCES

- 3- 1 Anon, Resources and Man, W. H. Freeman Co., San Francisco, 1969.
- 3- 2 Baum, W. A., "Meteorology and Utilization of Solar Energy", in Solar Energy Research, F. Daniels and J. A. Duffie, eds., Univ. of Wisconsin Press, p. 15, 1955.
- 3- 3 Meinel, A. B., and Meinel, M. P., Briefings Before the Task Force on Energy of the U.S. House of Representatives, V. III, U.S. Gov't. Printing Office, Washington D.C., 1972.
- 3- 4 Cherry, W. R., "The Generation of Pollution-Free Electrical Power from Solar Energy", J. of Engineering for Power, p. 78, April, 1972.
- 3- 5 Meinel, A. B., and Meinel, M. P., "Is It Time for a New Look at Solar Energy", Bull. of Atomic Scientists, V. 27, p. 32, 1971.
- 3- 6 Ralph, E. L., "Large Scale Solar Electric Power Generation", Solar Energy, V. 14, p. 11, 1972.
- 3- 7 Vermishev, K. Kh., "Some Problems in the Long Range Forecasting of Power Generation and Solar Energy Utilization", Applied Solar Energy, V. 6, p. 1, 1972.
- 3- 8 Lof, G. O. G., et al, "Solar Energy Utilization for House Heating", Report no. PB 25375, Dept. of Commerce, Wash. D.C., 1946.
- 3- 9 Telkes, M., "Solar Heat Storage", in Solar Energy Research, F. Daniels and J. A. Duffie, ed., Univ. of Wisconsin Press, p. 57, 1955.
- 3-10 Baranov, V. I., Muchnik, C. F., and Trushevskii, S. N., "Investigation of High Temperature Solar Energy Absorbers and Thermal Storage Devices", in Semiconductor Solar Energy Converters, V. A. Baum, ed., Consultant's Bureau, New York, p. 183, 1969.
- 3-11 Meinel, A. B., and Meinel, M. P., "Physics Looks at Solar Energy", Physics Today, V. 52, p. 44, 1972.
- 3-12 McCaull, J., "Windmills", Environment, V. 15, n. 1, pp 6-17, January, 1973.
- 3-13 Putnam, P. C., Power from the Winds, Van Nostrand, 1948.
- 3-14 NSF/NASA Solar Energy Panel, An Assessment of Solar Energy as a National Energy Resource, Univ. of Maryland, December, 1972.
- 3-15 Theobald, P. K., et al, "Energy Resources of the United States", Geological Survey Circular 650, U. S. G. S., Wash. D. C., 1972.
- 3-16 "The Potential for Energy Conservation", A staff study for the Office of Emergency Preparedness, Office of the President, Wash. D. C., October, 1972.
- 3-17 "Clean Energy from Coal - A National Priority", 1973 Annual Report, Calendar Year 1972, Office of Coal Research, Wash. D. C., 1973.
- 3-18 Post, R. F., "The Uncertain Certainty", Bull. At. Sci., V. 27, pp. 42-48, October, 1971.
- 3-19 Macmillan, D. P., and Balcomb, J. D., "Nuclear Reactors for High Temperature Process Heat - A Survey of Reactor Types and Temperature Regimes", LASL Paper LA-UR-73-877. Los Alamos Scientific Laboratory, Los Alamos, N. M., Paper presented to the 166th National A.C.S. Meeting, August 27, 1973.
- 3-20 McTague, P. J., Davidson, G. J., Bredin, R. M., and Herman, A. A., "The Evolution of Nuclear Plant Costs", Nuclear News, V. 15-2, pp 31-35, February, 1972.
- 3-21 Leeth, G. G., "Nuclear Power Plants for Hydrogen Production", G. E. Publication 72TMP-52, General Electric Company - TEMPO, Santa Barbara, Calif., November, 1972.
- 3-22 Anderson, J. H. and Anderson, J. H., Jr., "Thermal Power from Sea Water", Mechanical Engineering, V. 88, n. 4, April, 1966.

- 3-23 Heronemus, W. E., "The United States Energy Crisis: Some Proposed Gentle Solutions", ASME/IEEE Joint meeting, West Springfield, Mass., January 12, 1972.
- 3-24 Walters, S., "Thermal Sea Power", Mechanical Engineering, V. 93, n. 10, October, 1971.
- 3-25 Matz, W. D., "Ocean Temperature Gradients: Solar Power from the Sea", Science, V. 180, n. 4092, June 22, 1973.
- 3-26 Briefings before the Task Force for Energy, Committee on Science and Astronautics, U.S. House of Representatives, 92nd Congress, Serial U, Wash., D. C., p. 126, 1972.
- 3-27 Weinberg, A. M., "Long-Range Approaches for Resolving the Energy Crisis", Mechanical Engineering, V. 95, n. 6, June, 1973.
- 3-28 Blankenship, D. T., and Winget, G. D., "Hydrogen Fuel: Production by Bio-conversion", 8th Intersociety Energy Conversion Engineering Conference, Univ. of Pennsylvania, Philadelphia, Pa., August, 1973.
- 3-29 Maugh, T. H., "Fuel from Wastes: A Minor Energy Source", Science, V. 176, November 10, 1972.
- 3-30 Mrochek, J. E., "The Economics of Hydrogen and Oxygen Production by Water Electrolysis and Competitive Processes", in Grigorieff, W. W., ed., Abundant Nuclear Energy, pp 107-22, U.S. Atomic Energy Commission, Wash. D. C., 1969.
- 3-31 Gregory, D. P., "The Hydrogen Economy", Scientific American, V. 228, n. 1, pp 13-21, 1973.
- 3-32 Russell, J. H., Nutall, L. J., and Fickett, A. P., "Hydrogen Generation by Solid Polymer Electrolyte Water Electrolysis", presented at the symposium on "Chemical Aspects of Hydrogen as a Fuel", 166th National American Chemical Society Meeting, Chicago, Ill., August, 1973.
- 3-33 Gregory, D. P., "A Hydrogen-Energy System", Publication no. L 21173, Institute of Gas Technology, Chicago, Ill., August, 1972.
- 3-34 Kerns, G. P., "Hydrogen Production for Eco-Energy", Publication 72TMP-53, General Electric - TEMPO, Santa Barbara, Calif., November, 1972.
- 3-35 Stuart, A. K., "Modern Electrolyser Technology", presented at the American Chemical Society Symposium on Non-Fossil Fuels, Boston, Mass., April, 1972.
- 3-36 Allis-Chalmers Manufacturing Company, "Design Study of Hydrogen Production by Electrolysis", Publication no. ACSDS 0106643, Milwaukee, Wis., Oct., 1966.
- 3-37 Schade, C. W., et al, "Energy Depot Electrolysis Systems Study", V. 1, Final Report TID 20441, Allison Division of General Motors, Report EDR 3714, U.S. Atomic Energy Commission, Wash. D. C., June, 1964.
- 3-38 Hausz, W., Leeth, G., Lueck, D., and Meyer, C., "Hydrogen Systems for Electric Energy", Publication 72TMP-15, General Electric - TEMPO, Santa Barbara, Calif., April, 1972.
- 3-39 Titterington, W. A., and Fickett, A. P., "Electrolytic Hydrogen Fuel Production with Solid Polymer Electrolyte Technology", presented at the 1973 Intersociety Energy Conversion Engineering Conference, Philadelphia, Pa., August, 1973.
- 3-40 Hausz, W., Leeth, G., Meyer, C., "Eco-Energy", presented at the 1972 Intersociety Energy Conversion Engineering Conference, San Diego, Calif., IECEC Paper 01-72906, September, 1972.
- 3-41 Hallett, N. C., Air Products and Chemicals, Inc., "Study, Cost and System Analysis of Liquid Hydrogen Production", NASA CR 73-226, June, 1968.
- 3-42 Costa, R. L., and Grines, P. G., "Electrolysis as a Source of Hydrogen and Oxygen", Chem. Eng. Progr. Symp. Ser. No. 71, V. 63, pp 43-58, 1967.
- 3-43 Oak Ridge National Laboratory, "Nuclear Energy Centers, Industrial and Agro-Industrial Complexes", ORNL 4290, U.S. Atomic Energy Commission, Wash. D. C., November, 1968.
- 3-44 Synthetic Fuels Panel, "Hydrogen and other Synthetic Fuels - A Summary of the work of the Synthetic Fuels Panel", Report no. TID-26136, U.S. Government Printing Office, Wash. D. C., September, 1972.
- 3-45 Michel, J. W., "Hydrogen and Synthetic Fuels for the Future"; presented at the Symposium on "Chemical Aspects of Hydrogen as a Fuel", 166th National American Chemical Society Meeting, Chicago, Ill., August, 1973.
- 3-46 Hanneman, R. E., and Wentorf, R. H.,

- "Thermochemical Systems for Hydrogen Generation", presented at the Symposium on "Chemical Aspects of Hydrogen as a Fuel", 166th National American Chemical Society Meeting, Chicago, Ill., August, 1973.
- 3-47 Ross, P. N., and Hausey, L. G., "Some Future Dimensions of Electric Power Generation", Westinghouse Engineer, pp 1-7, January, 1971.
- 3-48 Mills, G. A., "Conversion of Coal to Gasoline", I & EC, V. 61, n. 7, July, 1969.
- 3-49 Consolidation Coal Co., "Summary Report on Project Gasoline, V. 1," R & D Report 39, Contract No. 14-01-0001-310, Office of Coal Research, Wash. D. C., April, 1970.
- 3-50 FMC Corp., "Char-Oil-Energy Development - Project COED", R & D Report 73, Contract No. 14-32-0001-1212, Office of Coal Research, Wash. D. C., December, 1972.
- 3-51 Pittsburg and Midway Coal Mining Co., "Development of a Process for Producing an Ashless, Low-Sulfur Fuel from Coal, V. 1", R & D Report No. 53, Contract No. 14-01-0001-496, Office of Coal Research, Wash. D. C., May, 1972.
- 3-52 Ralph M. Parsons Co., "1970 Final Report - CONSOL Synthetic Fuel Process", R & D Report No. 45, Contract No. 14-01-0001-225, Office of Coal Research, Wash. D. C., July, 1970.
- 3-53 Hydrocarbon Research, Inc., "Project H-Coal Report on Process Development", R & D Report No. 26, Contract No. 14-01-0001-47, Office of Coal Research, Wash. D. C., November, 1968.
- 3-54 ARCO Chemical Co., "Project Seacoke - V. 1", R & D Report No. 29, Contract No. 14-01-0001-473, Office of Coal Research, Wash. D. C., January, 1970.
- 3-55 "Evaluation of Coal-Gasification Technology - Part 1, Pipeline Quality Gas", R & D Report No. 74, Contract No. 14-32-0001-1216, Office of Coal Research, Wash. D. C., December, 1972.
- 3-56 Wen, C. Y., et al, "Comparison of Alternate Coal Gasification Processes for Pipeline Gas Production", Paper presented at the 65th Annual Meeting of the American Institute of Chemical Engineers, New York, N. Y., November, 1972.
- 3-57 Papamarcos, John, "Gas from Coal", Power Engineering, February, 1973.
- 3-58 Siegel, H. M. and Kalina, T., "Technology and Cost of Coal Gasification", Mechanical Engineering, May, 1973.
- 3-59 Feldman, H. F., et al, "Supplemental Pipeline Gas from Coal by the Hydrane Process", Paper presented at the 71st National Meeting, American Institute of Chemical Engineers, Dallas, Texas, February, 1972.
- 3-60 "Evaluation of Coal-Gasification Technology - Part 2, Low and Intermediate Btu Gases", R & D Report No. 74, Contract No. 14-32-0001-1216, Office of Coal Research, Wash. D. C., to be published in late 1973.
- 3-61 Dragos, John, "Coal Industry Problems", Paper presented at the American Society of Mechanical Engineers Energy Crisis Symposium, Columbus, Ohio, May, 1973.
- 3-62 Weir, J. P., "Coal Supply for Gasification Plants", Paper presented at the 1973 Coal Convention, American Mining Congress, Pittsburg, Pennsylvania, May, 1973.
- 3-63 Higgins, G. H., "A New Concept for In Situ Coal Gasification", Contract NO. W-7405-Eng-48, U.S. Atomic Energy Commission, Wash. D. C., September, 1972.
- 3-64 "A Report of the Study Committee on the Potential for Rehabilitating Land Surface Mined for Coal in the Western United States", National Academy of Sciences, August, 1973.
- 3-65 Funk, J. E. and Reinstorm, R. M., "Energy Requirements in the Production of Hydrogen from Water", IEC Proc. Des. & Dev., V. 5, p 336, 1966.
- 3-66 Funk, J. E., "Thermodynamics of Multi-Step Water Decomposition Processes", Symposium on Non-Fossil Chemical Fuels, ACS 163rd National Meeting, Boston, Mass., April, 1972.
- 3-67 Knoche, M., "Thermodynamic Aspects of Coupled Chemical Reactions", EUR/C-IS/1062/1/69, Euratom, Ispra, Italy, December, 1969.
- 3-68 De Beni, G., "Hydrogen Production Cyclic Process", French Pat. 2.035.558, February 17, 1970, Ger. Offen. 2.005.015, September 10, 1970.
- 3-69 De Beni, G., and Marchetti, C., "Hydrogen, Key to the Energy Market", Eurospectra, V. 9, n. 2, p. 46, 1970.
- 3-70 De Beni, G., and Marchetti, C., "Mark 1, a Chemical Process to Decompose Water using Nuclear Heat", Symposium on Non-Fossil Chemical Fuels, ACS

- 163rd National Meeting, Boston, Mass., April 10-14, 1972.
- 3-71 "Hydrogen Production from Water using Nuclear Heat", Report No. 1, EUR 4776e, December, 1970, Report No. 2, EUR 4955e, December, 1971, Report No. 3, EUR/C-IS/35/73e, December, 1972.
- 3-72 Hardy, C., "Thermal Decomposition of Water using Cycles of the FeCl_2 Family", Report EUR 4958f, 1973.
- 3-73 Kobe, K. A., Inorganic Process Industries, McMillan Co., New York, pp 91-92, 1948.
- 3-74 Funk, J. E., and Reinstrom, R. M., "System Study of Hydrogen Generation by Thermal Energy", V. 2, Supplement A of GM Report TID 20441, Wash. D. C., June, 1964.
- 3-75 Knoche, K. F., and Schubert, J., "Mollier Diagram for the Study of Thermonuclear Water Splitting Processes", VDI Forsch-Heft, V. 38, n. 549, p. 25, 1972.
- 3-76 Miller, A. R., Jaffé, H., "Process for Producing Hydrogen from Water using an Alkali Metal", U. S. Pat. 3.490.871, January 20, 1970.
- 3-77 Abraham, B. M., and Schreiner, F., "A Low Temperature Thermal Process for the Decomposition of Water", Science, V. 180, p. 959, 1973.
- 3-78 Souriau, D., "Utilization of the Heat Energy of Nuclear Reactors", Ger. Pat. 2.221.509, November 16, 1972.
- 3-79 Williams, D. D., et al, "The Reactions of Molten Sodium Hydroxide with Various Metals", Jour. Am. Chem. Soc., V. 78, p. 150, 1956.
- 3-80 Heidt, L. J., "Photochemistry", McGraw-Hill Encyclopedia of Science and Technology, McGraw-Hill Book Co., Inc., New York, pp 137-138, 1960.
- 3-81 Heidt, L. J., Solar Energy Research, F. Daniels and A. Duffie, eds., Univ. of Wisconsin Press, Madison, Wis., pp 203-220, 1955.
- 3-82 Kolp, D. and Thomas, H. C., "Rates of Water Oxidation in Ceric Perchlorate Solutions". Journal of the American Chemical Society, V. 71, p. 3074, 1949.
- 3-83 Heidt, L. J., Proc. World Symposium on Applied Solar Energy, Stanford Res. Institute, Menlo Park, Calif., pp 275-280, 1956.
- 3-84 Fujishima, A., and Honda, K., "Electrochemical Photolysis of Water at a Semiconductor Electrode", Nature, V. 238, pp 37-38, July 7, 1972.
- 3-85 Gerisher, H., "Electrochemical Behavior of Semiconductors under Illumination", Journal of the Electrochemical Society, V. 113, n. 11, pp 1174-1181, November, 1966.
- 3-86 Rabinowitch, E., Foreword in "Energy Conversion by the Photosynthetic Apparatus", Brookhaven Symposia in Biology, No. 19, BNL-USAEC, June, 1966.
- 3-87 Krampitz, L. O., Case Western Reserve Univ., Cleveland, Ohio, Personal Communication, July, 1973.
- 3-88 Sanders, A. P., Downs, W. R., McBryar, H., Williams, R. J., Johnson Space Center, NASA, Houston, Texas, Patent Case NASA/MSC 12600-1, 1973.
- 3-89 Ford, N. C. and Kane, J. W., "Solar Power", Bull. At. Sci., V. 27, pp 27-31, October, 1971.
- 3-90 Glaser, P. E., "Satellite Solar Power Station", Solar Energy, V. 12, p. 353, 1969.
- 3-91 Glaser, P. E., "Satellite Solar Power Station: An Option for Power Generation", 7th Intersociety Energy Conversion Engineering Conference, San Diego, Calif., p. 507, 1972.
- 3-92 Ralph, E. L., "Large Scale Solar Electric Power Generation", Solar Energy, V. 14, p. -1, 1972.
- 3-93 Wolf, M., "Cost Goals for Silicon Solar Arrays for Large Scale Terrestrial Applications", 9th IEEE Photovoltaic Specialists Conference, p. 342, 1972.
- 3-94 Spakowski, A. and Shure, L., "Estimated Cost of Large Scale Power Generation using Solar Cells", 9th IEEE Photovoltaic Specialists Conference, p. 353, 1972.
- 3-95 Francia, G., "Pilot Plants of Solar Steam Generating Stations", Solar Energy, V. 12, p. 51, 1968.
- 3-96 Meinel, A. B., and Meinel, M. P., "Thermal Performance of a Linear Solar Collector", ASME Paper No. 74-WA/Sol-7.
- 3-97 Daniels, G. E., ed., "Terrestrial Environment (Climatic) Criteria Guidelines for use in Space Vehicle Development, 1971 Revision", NASA Technical Memorandum TMX-64589, pp 2.6-2.9, May, 1971.

- 3-98 Jagger, J., Introduction to Research in Ultraviolet Photobiology, Prentice-Hall, Inc., Englewood Cliffs, N. J., pp 18-19, 1967.
- 3-99 West, R. E., et al, "Investigation for the Purpose of Improving the Efficiency of Utilization of Solar Energy by the Decomposition of Water into Hydrogen and Oxygen", Contract AF 19 (604)-8420, Project No. 6694, Task 66940, P.E.C. Corporation, Boulder, Colorado, May, 1963.
- 3-100 Heronemus, W. E., "Pollution-Free Energy from Offshore Winds", 8th Annual Conference and Expositions Marine Technology Society, Wash. D. C., 1972.
- 3-101 Quode, R. N., "High-Temperature Gas-Cooled Reactors for Process Heat", Power Engineering, April, 1973.
- 3-102 Eastlund, B. J., and Gough, W. E., "Generation of Hydrogen by Ultra-Violet Light Produced by the Fusion Torch", Paper presented at the 163 National Meeting of the American Chemical Society, Boston, Mass., April 9-14, 1972.

ORIGINAL PAGE IS
OF POOR QUALITY

CHAPTER 4

TRANSMISSION AND STORAGE OF HYDROGEN

4

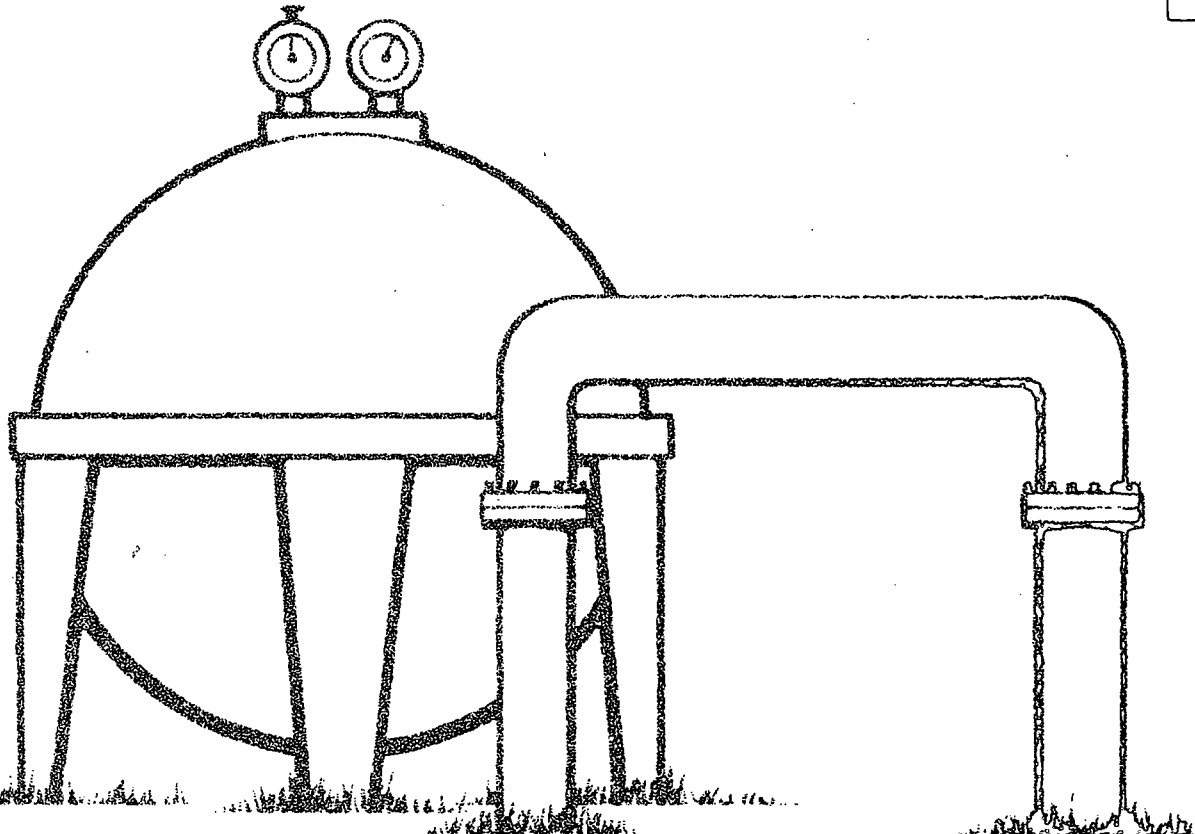

4.1 INTRODUCTION

All economically feasible methods for the production of hydrogen will result in gaseous hydrogen rather than a liquid or a hydride. In order to transmit hydrogen from producer to consumer it will be necessary to utilize some of the present transmission and storage techniques. These techniques and methods, along with possible future techniques, are evaluated in relationship to a hydrogen economy.

One important question arises in studies concerned with the transmission of hydrogen: Can the present natural gas transmission system be used? The answer is not clear because of possible embrittlement of pipeline material. There is the possibility that an entirely new transmission and storage network will be necessary.

Besides economics, process efficiency and materials, other subtle factors are important. Environmental and social costs have become a fact of life, and a complete analysis requires that we take these factors into account.

Liquid hydrogen as an energy carrier must be considered because of the properties of the liquid - some generally advantageous, some not so advantageous. Transmission and storage characteristics of liquid hydrogen are unique and specially trained personnel are needed to handle it in this form. The transmission of liquid hydrogen provides the possibility of dual systems, i.e., cryogenic-electrical cables, which need to be analyzed and compared with other transmission methods.

Normally energy is not stored in solid form because of the economics of transmission and distribution. Various hydrogen-metal storage systems have been proposed which can give some interesting advantages, particularly from the safety standpoint. Economics of such systems are questionable and must be carefully analyzed in order to obtain a fair comparison of gaseous and liquid hydrogen storage systems.

4.2 A GASEOUS HYDROGEN/NATURAL GAS SYSTEM COMPARISON

4.2.1 A HYDROGEN FUEL SYSTEM

In our economy gaseous hydrogen has a potential as an energy carrier. Hydrogen will be produced and ultimately used as a gas. The manner in which hydrogen is transmitted from the producer to the user will be one of the more important factors to consider in the overall economy of a hydrogen fuel system.

When we consider hydrogen as a gaseous fuel, we can visualize a large scale system

similar to that used for natural gas today. The consumption of natural gas, at the present time, represents almost one-third of the total energy used (4-1).

Essentially all of the natural gas used is delivered by gas pipeline directly from the well to the user. The efficiency of this transmission method is quite good compared to alternate transmission methods. A small fraction of the gas entering the pipeline is used as an energy source to pump the remaining gas through the pipe system.

The most economical way to supply the bulk of the hydrogen fuel will be by gas pipeline. Thus, the hydrogen will be distributed in the same form as it is produced and eventually used. If gaseous hydrogen is converted to other energy forms for transmission, the overall efficiency of the fuel system will be reduced, since each conversion will require an additional energy input. There will be some instances in which it may be necessary to transmit hydrogen in a form other than gas, but in these cases the cost of the fuel to the user will be higher than the cost in an optimized gas pipeline system. A hydrogen gas system would undoubtedly be similar to the existing natural gas pipeline system, since the present users of natural gas would also be potential hydrogen users. In fact, initially it may be more economical to adapt some portion of the existing natural gas system to a hydrogen system, if investigation shows this to be technically feasible.

4.2.2 THE EXISTING NATURAL GAS SYSTEM

The existing natural gas pipeline system consists of three basic components: transmission, storage and distribution systems. At first natural gas was utilized near the source of supply only, but, through the development of high pressure, large diameter lines, natural gas is presently transmitted as far as 2000 miles (3.22×10^6 m). Transmission pressures of 60 to 1000 psi (4.14 to 68.9×10^5 N/m²) gauge are used. Storage near the consumption centers has become a necessity as a safeguard in case of pipeline failures and to handle the peak demand, while maintaining near maximum gas transmission throughout the year. As an example of the non-uniform demand, because of heating requirements residential customers use five times as much gas in winter as in summer (4-2).

The distribution system begins with the transmission main operating at pressures of 60 to 250 psi (4.14 to 17.2×10^5 N/m²). (All pressures are gauge pressures.) The gas distribution continues from the transmission main through the truck main to the feeder mains and finally to distribution mains. The pressure in the distribution mains range from 6 inches water column (1.49×10^{-3} m) to 100 psi (6.89×10^5 N/m²). Residential and commercial appliances general-

ly utilize natural gas at pressures below 0.5 psi ($3.45 \times 10^3 \text{ N/m}^2$), while some industrial use is at pressures of approximately 50 psi ($3.45 \times 10^5 \text{ N/m}^2$).

Natural gas is stored in various types and sizes of container and at various pressures. Local storage in large low-pressure cylindrical tanks up to 10^6 cu. ft. ($2.33 \times 10^4 \text{ m}^3$) with pressures under 0.5 psi ($3.45 \times 10^3 \text{ N/m}^2$) are sometimes used. In rural areas, high pressure bottle-type or pipe-type holders have been used for underground storage. Pressures over 2,000 psi ($1.38 \times 10^7 \text{ N/m}^2$) and capacities of 1.5×10^6 to 120×10^6 cu. ft. (4.25×10^4 to $339 \times 10^4 \text{ m}^3$) have been used in installations of this type. Daily peak-shaving requirements may also be provided by transmission line or line-pack storage. During periods of low demand the operating pressure may be increased in a line. An increase of 100 psi ($6.89 \times 10^5 \text{ N/m}^2$) will store approximately 7 times the pipeline volume. The main disadvantage of line-pack storage is that a break in the line would cause a loss of transmission capacity as well as a large portion of the gas stored in the line.

Natural gas storage for large systems utilizes underground gas storage by injection into natural rock or sand reservoirs

such as depleted oil and gas fields. Aquifers are also used by displacing water with the natural gas. There are some essential reservoir characteristics which will allow only certain formations to be used for underground storage. Additionally the storage field should be near markets and the main transmission lines; and be large enough to supply the seasonal peak-shaving requirements of the pipeline system. Excess gas produced in the summer may be injected into the underground storage field and withdrawn for winter use. In 1970, there were 325 underground pools in 26 states with a majority of the underground storage in the northeastern part of the country (4-2). The amount of natural gas withdrawn from underground storage in 1970 was equal to approximately a 23 day supply, and the total storage capacity was equal to an 80 day supply, based on the average daily consumption. For systems where underground large-scale storage reservoirs are not available, liquefied natural gas storage is used to provide daily and seasonal peak-shaving. Additional data on natural gas pipelines may be obtained from the Gas Engineers Handbook (4-3). Table 4-1 clarifies the importance of the existing natural gas system to our economy (4-2).

TABLE 4-1
NATURAL GAS SYSTEM DATA
(UNITED STATES 1970)

CONSUMPTION	
63.8 x 10 ⁹ cu. ft./day	23.34 x 10 ¹⁵ Btu/Yr.
STORAGE CAPACITY	
UNDERGROUND GAS RESERVOIR	5,178 x 10 ⁹ cu. ft.
LIQUEFIED NATURAL GAS (SCF)	15 x 10 ⁹ cu. ft.
TOTAL	5,193 x 10 ⁹ cu. ft.
LENGTH OF PIPELINE	
FIELD AND GATHERING MAIN	66,556 mi.
TRANSMISSION MAIN	252,621 mi.
DISTRIBUTION MAIN	595,653 mi.
TOTAL	914,830 mi.
NUMBER OF CUSTOMERS (METERS)	
RESIDENTIAL	38,097,000
COMMERCIAL	3,131,000
INDUSTRIAL	199,000
TOTAL	41,427,000

4.2.3 EXISTING HYDROGEN HANDLING SYSTEMS

Present hydrogen pipelines in refineries and chemical plants operate at pressures in excess of 1000 psi (6.89×10^6 N/m²) for short distances. Pipelines up to 320 miles (5.15×10^5 m) in length with pipe sizes from 6 to 12 inches (0.152 to 0.305 m) are presently operated in Germany and the United States. Smaller quantities of hydrogen gas are supplied in high pressure tanks.

Manufactured gas containing 50 to 80 percent hydrogen is presently distributed in Europe. Some of these retail distribution pipeline systems are presently being converted to natural gas. Similar conversion to natural gas has occurred in the United States, but some manufactured gas is still distributed to residential customers in parts of the United States. A direct analogy, however, between a hydrogen gas pipeline and a pipeline containing a hydrogen rich gas may not be appropriate. A discussion of potential problems in a hydrogen gas pipeline is given in Section 4.2.6

4.2.4 ECONOMICS OF TRANSMISSION

The transmission of energy may be accomplished economically by means of a hydrogen gas pipeline system. At the present time, the cost to transmit hydrogen in large quantities has been estimated to be at most 2 to 3 times the cost of natural gas transmission (4-4, 4-5). In comparison, the cost of overhead electrical transmission is 5 times the estimated cost of hydrogen transmission while the cost of underground electrical transmission is approximately 7 times the cost of overhead transmission (4-6). Figure 4-1 shows the relative costs of various systems which furnish energy from a source to a load center 300 miles (4.82×10^5 m) away. For reference, the electrical production costs

NASA-573-2578

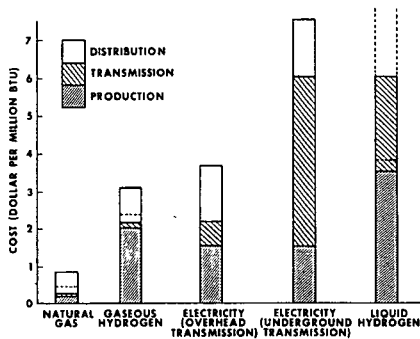

FIGURE 4-1
COMPARATIVE COST OF DELIVERED ENERGY

are taken as 5 mil/kWh (\$1.50 per billion Joules) and the hydrogen is assumed to be produced electrolytically from this electricity. It is apparent that if the energy is required for heating only, the lower hydrogen transmission cost will offset the added production cost, if the electricity must be transmitted any appreciable distance. In fact, transmission of over 300 miles (4.82×10^5 m) by overhead cable or 35 miles (5.63×10^4 m) by underground cable will make the electrical energy cost more.

Even if the hydrogen is again converted to electricity at the load center, the hydrogen transmission system will reduce costs for long transmission distances. In this case, transmission by overhead cable of over 1200 miles (1.93×10^6 m) will make the cost of electrical energy higher.

The cost of hydrogen derived from coal would be approximately one-half that of electrolytic hydrogen. Based on this assumption and an equal transmission distance the cost of hydrogen would be much less than the cost of electricity. Hydrogen could be competitive with electricity even when the hydrogen transmission distance is longer than that of electric transmission.

4.2.5 A HYDROGEN PIPELINE SYSTEM

The development of a hydrogen pipeline system can be accomplished in several ways but there are many indeterminate factors which would affect the development. Presumably some of the existing natural gas pipelines will be incorporated into the hydrogen network. The manner in which such a conversion might be accomplished warrants a detailed study. The location of the hydrogen plant with respect to the existing natural gas transmission and distribution systems would be needed for such a study. Existing natural gas transmission lines could be used to transmit an equal amount of energy in the form of hydrogen gas, but such a system would require approximately four times the present compressor capacity and over five times the compressor horsepower (4-4). This would not be an optimum design for the compressors; however, if the existing pipe could be used, the overall cost of such a system would be favorable when compared to the cost of a new optimized system.

The existing transmission lines originate in the southwest and deliver gas to midwest, the east and west coasts but it is likely that hydrogen may not be generated in the southwest. It may be more economical to generate the hydrogen closer to the large markets in the coastal areas. If this were the case new trans-

mission mains could be installed from the hydrogen plant to the existing distribution systems along the coast. Since the coastal areas are at the end of the present natural gas pipelines, it would be possible to convert a large coastal area to hydrogen while inland areas were allowed to continue using natural gas. This would provide a method of gradually converting all of the existing natural gas distribution systems to hydrogen.

If the implementation of a hydrogen pipeline system occurred in this manner, the inland areas would be at the end of the hydrogen pipeline. Since the energy demand in the inland areas is much less than in the coastal areas, it would now be possible to use the existing natural gas transmission mains to deliver hydrogen to the inland regions economically with a minimum of modification. Using the existing compressor capacity at approximately one-tenth the present compressor horsepower, the energy delivery rate of hydrogen would be approximately one-fourth the present natural gas energy delivery rate (4-4).

The possibility of converting existing natural gas distribution piping to hydrogen also exists. Since the distribution system is generally a low pressure system, it is possible that existing natural gas distribution piping would be adequate to deliver the required volume of hydrogen gas without danger of hydrogen environment embrittlement.

The manner in which a hydrogen pipeline system may evolve is not totally predictable. A hydrogen system may initially develop parallel to the existing natural gas system. More practical, however, may be a hydrogen pipeline system for only the newly developed areas. Also feasible is the use of hydrogen as an industrial and electric generation fuel in a new pipeline system.

In a hydrogen pipeline system, the large-scale storage of hydrogen will be necessary for peak-shaving. The feasibility of using existing storage tanks must take into consideration the fact that a natural gas storage tank will store at design pressure only one-third as much energy when filled with hydrogen. This may require that existing storage facilities be enlarged. The feasibility of using existing underground storage reservoirs will also be considered, since this storage method is much less costly than storage by any other means. Underground storage of helium in the Cliffside field in Texas, a helium-bearing natural gas field, is an example of this type of storage facility (4-7). Helium has been successfully stored and withdrawn from the field since 1945. The storage field consists of a porous rock stratum 120 to 200 feet (36.5 to 61 m) thick, lying 3,500 feet (1.067×10^3 m) below the surface and occupying 50,000 acres (2.02×10^8 m²). Other storage methods will have to be used if low cost underground storage in

depleted gas fields or aquifers is not available. This will cause some slight increase in the cost of hydrogen. A cost analysis using liquid hydrogen storage is presented in Section 4.3.

4.2.6 POTENTIAL HYDROGEN EMBRITTLEMENT

When considering the use of existing natural gas pipelines for transmission of gaseous hydrogen (4-4, 4-5) there are two major factors that need to be resolved. One of these factors, discussed in the previous section, is the change in compressor capacity needed to pump hydrogen. The other factor is the metallurgical problem that can occur if there is a switch from natural gas to hydrogen.

A general discussion of the compatibility of hydrogen with materials is given in Section 5.4. The particular metallurgical problem that is of most concern if we are to use existing pipelines is known as hydrogen environment embrittlement. There is more concern than usual at this point in time because this particular embrittlement problem has been recognized only since the mid 1960's and extensive research has not been conducted in this area until the last several years (4-8, 4-9). The reviews of Jewett (4-9) and Gray (4-10) have been particularly useful in clarifying this metallurgical problem.

Hydrogen environment embrittlement may be defined as follows: 'When a metal susceptible to hydrogen environment embrittlement is plastically deformed in an environment containing hydrogen gas, cracking can occur at the surface with possible propagation of the crack into a catastrophic failure.' This is an explanation describing the minimum requirements for the production of embrittlement. An important point is that this is a surface phenomenon and not a chemical or internal phenomena as is the situation in most hydrogen embrittlement problems. The problem is usually observed in relatively pure hydrogen at high pressures and temperatures close to ambient. However, research (4-9) has shown that cracking can occur over a range of temperatures in the presence of some impurities at pressures less than one atmosphere. Gray (4-10) emphasizes the point, "Embrittlement might occur to a greater degree and over a broader range of temperatures and pressures than determined in laboratory tests to date."

Presently known factors that affect the use of existing pipelines are:

- susceptibility of presently used alloys
- plastic deformation due to high pressure
- transmission of high purity hydrogen.

There has been no known research performed on pipeline steels regarding susceptibility of metals to hydrogen environment embrittlement. There has, however, been work performed on steels that are in the same low carbon steel alloy class (4-9). There investigations indicate this class of steel undergoes severe embrittlement when exposed to high purity hydrogen at high pressure. This factor is considered an unfavorable aspect in utilizing existing pipelines for hydrogen transmission.

Plastic deformation of the metal in the presence of hydrogen is required before hydrogen environment embrittlement can occur. For an alloy in which there are no residual stresses involved, the permanent deformation is normally considered to take place at an applied stress equivalent to the yield strength of the material. Actually some permanent deformation takes place at a stress level slightly below the yield strength. Nevertheless engineering design, particularly pipeline design, is based on the yield strength of the material. Pipeline codes allow present natural gas pipelines to operate at 72 percent of yield strength or a 1.38 safety factor. Pipeline companies generally operate as close to this figure as is economically possible. Combinations of residual stress and stress concentrations that occur in fabrication of the pipeline, or external stresses caused by pipeline movement, can add to the working stress value and actually cause yielding at localized points. In the presence of natural gas this localized yielding has not been serious, but in the presence of hydrogen the localized yielding might produce a crack ascribed to hydrogen environment embrittlement.

Proponents of utilizing existing natural gas pipelines cite examples of existing hydrogen lines such as those operated by Air Products and Chemicals, Inc. in Houston, Texas; and Chemische Werke Huls AG in the Ruhr area of Germany (4-4). These pipelines have been operating for many years without an apparent degradation due to hydrogen; however, analysis of the pipeline operating conditions indicate they would not be susceptible to hydrogen embrittlement. In the case of the Houston pipeline the operating pressure is 200-250 psi ($13.8 - 17.2 \times 10^5 \text{ N/m}^2$), yielding a safety factor of 6 to 8. The operating pressure of the German pipeline is only 150 psi ($1.03 \times 10^5 \text{ N/m}^2$). In these cases we would expect no localized yielding of the material since the working stress is low. Therefore, no hydrogen environment embrittlement would be probable. If existing natural gas pipelines were stressed at the 1.38 safety factor level, as is implied in the hydrogen economy proposals, localized deformation could possibly occur. This is one of the conditions needed for

hydrogen environment embrittlement.

The purity of hydrogen appears to be a significant factor in the susceptibility of metals and alloys to hydrogen environment embrittlement. It has been determined that certain impurities can inhibit or eliminate the susceptibility of a metal to hydrogen environment embrittlement. One of these is an oxygen impurity content of 200 parts per million. Other impurities such as carbon dioxide, water vapor, ammonia and sulfur dioxide also inhibit embrittlement, whereas impurities such as nitrogen, helium and argon have little effect.

Most of the chemical and thermochemical processes proposed to produce hydrogen will not give gaseous hydrogen of ultra high purity. For example, 99.7 percent pure hydrogen, now being produced in one steam reforming plant would probably not cause embrittlement. But, electrolysis capable of producing hydrogen of 99.99 percent purity could cause embrittlement problems. It would probably be unreasonable to expect that hydrogen of purity greater than 99.98 percent would be piped in large quantities in a hydrogen economy. Taking into account these facts, it can be assumed that impurity would be a favorable factor in pumping hydrogen through existing pipelines.

Another case of note is hydrogen gas obtained from liquid hydrogen storage. In the liquefaction process the hydrogen is purified to a high level. For example, oxygen content is reduced to less than one part per million to avoid the growth of oxygen crystals in the liquid hydrogen. When the liquid is later returned to the gas phase it is extremely pure. Perhaps impurities must be added at this point to protect downstream systems from hydrogen environment embrittlement.

In summary, it would appear that most operating conditions would favor the use of existing pipelines. Until safety research is undertaken on pipeline materials under actual operating conditions, hydrogen environment embrittlement is cause for caution.

4.3 LIQUID HYDROGEN

4.3.1 TECHNOLOGY OF LIQUEFACTION AND STORAGE

Although liquid hydrogen was first produced as a mist of fine droplets in 1884 and a true liquid in 1898, the first large scale liquefaction plant for hydrogen was not constructed in the U.S. until 1952. This first plant, constructed at the National Bureau of Standards Cryogenic Engineering Laboratory in Boulder, Colorado,

could produce about 0.5 tons/day (450 Kg/day) of liquid para-hydrogen. The output from this plant was used primarily in a program to develop materials, equipment and procedures for handling and storing liquid hydrogen safely. From this modest beginning the technology has expanded to the point where there are now several liquefaction plants in operation, the largest having a capacity of 60 tons/day (55,000 Kg/day). Liquid hydrogen is being shipped by tank truck, rail tanker and barge almost routinely and stored in insulated tanks with capacities up to 900,000 gallons (3,400 m³).

The liquefaction process for hydrogen is somewhat more complicated than for most other common gases, because the Joule-Thompson coefficient for hydrogen is negative at temperatures above 364°R (202°K), which is well below ambient temperature. Thus high pressure hydrogen gas will get warmer if allowed to expand while at room temperature. For this reason, liquid nitrogen pre-coolers are usually used and the liquefaction of nitrogen is a part of the hydrogen liquefier.

Added to this complication is the "ortho-para problem" of hydrogen. Ortho-hydrogen is different than para-hydrogen in that the electrons have an opposite spin direction. At room temperature gaseous hydrogen is 75 percent ortho and 25 percent para, while the equilibrium liquid is nearly pure para. The latent heat of conversion from ortho to para is greater than the latent heat of vaporization so that the conversion must be accomplished in the liquifier where this heat may be removed if the liquid is to be stored. Catalysts are incorporated in the liquefier plant to accelerate conversion to the para state (4-11).

The theoretical work of liquefaction of hydrogen is 5002 Btu/lb (1.16 x 10⁷ J/Kg), but it appears that there are rather severe practical limitations to approaching this value. While the figure of merit for nitrogen liquefaction is approaching 9/10, that is, the actual work required is only 10/9 times the theoretical work, it is felt that achieving a figure of merit greater than about one-third will not be feasible for hydrogen in a commercial plant. The work required for liquefaction is therefore taken as 15000 Btu/lb (34.9 x 10⁶ J/Kg). This includes conversion to the para state.

Transport and storage of liquid hydrogen has undergone considerable improvement in recent years, mainly due to the large quantities of liquid hydrogen used as fuel in the space program and the liquid hydrogen stored at the Nuclear Rocket Development Station in Nevada. The quantities needed in these two programs were so large that there was a strong impetus in developing improved pumps, pipes, tankers and storage containers.

Improvements in the area of insulators are indicative of what can be accomplished when it is apparent that there is economic justification. The standard of insulation in 1952 when the first sizable liquefier was built was high vacuum with silvered walls. Addition of one or more radiation baffels could reduce heat transfer but was expensive. Development of powder insulation such as perlite, which serves as a multiple radiation shield reduced heat transfer by about an order of magnitude from a simple vacuum. A vacuum in the powder filled space was still required but the pressure did not need to be as low. Further improvements were made by using alternate layers of glass fibers and metalized plastic film -- also in vacuum. One such insulator called Quilted Super Insulation (QSI) by Linde Corporation further reduces the heat leak by another order of magnitude.

The type of storage or transport container used and the type of insulation employed will depend upon the particular application. For example, 3 feet (91.44 cm) of evacuated perlite may be appropriate for a stationary storage tank. Since the fabrication cost of QSI is high, two inches (5.08 cm) would obviously be better than evacuated perlite for a rail transport tank where size rather than weight is the limiting factor (4-12).

The rate of development in this field makes it very difficult to project into the future. Simply looking back at the last ten years work in Liquefied Natural Gas (LNG) indicates what magnitude of change might be envisioned. Developments in LNG storage for peak-shaving capability have been substantial. Not all of these developments appear to be directly applicable to liquid hydrogen storage, but some may be with minor technological changes. In attempting to envision how hydrogen could replace natural gas, the work recently performed in LNG may be used as an indicator of what can be done -- not of how it will be done.

For example, the cryogenic in ground (CIG) storage system which utilizes frozen, moisture saturated, soil as the actual tank wall and insulation does not appear to be applicable to hydrogen at this time. The CIG concept makes possible large storage containers for LNG at low unit cost, but it appears that such containers that such containers would have to be lined and possibly insulated for hydrogen storage. Thus, simplicity, the major advantage of CIG, is largely lost. Technological development may change this situation, and hopefully such changes will make the use of liquid hydrogen more economical than indicated here.

4.3.2 THE ROLE OF LIQUID HYDROGEN

It is envisioned that in a hydrogen energy system there will be several areas

where liquid hydrogen may be used to improve the system. These improvements may be in the overall economics, in the reliability, or even in safety, depending on the particular system considered.

In any energy supply system the system must furnish energy on demand, and the demand is not generally constant. The fluctuating demand for energy makes it important to have a flexible supply system. If hydrogen gas were being used only for domestic heating the fluctuations in demand would be somewhat predictable since there would be a higher demand on cold days. If, however, we envision hydrogen taking over a large share of our uses of energy the pattern becomes more complex. We have previously provided an example of the use of liquid hydrogen for load leveling or peak-shaving. The assumptions may not be valid for many years but they should indicate the economics of using liquid hydrogen in this type of situation.

Another area where liquid hydrogen could possibly be useful is in supplying energy to a small town where the total use rate and distance from source might make a pipeline for hydrogen gas uneconomical. A set of relatively basic assumptions are used to develop a model to investigate this situation in Section 4.3.5.

One further suggested use of liquid hydrogen is in cooling a cryogenic electrical transmission cable. In this concept electrical energy and hydrogen energy flow in the same pipe. The economies are a result of the reduction of electrical energy lost through line resistance. While such a line has not been built and consequently any cost estimates are guesses, a few general comments about the system are appropriate.

4.3.3 THE ENERGY PIPE

The suggestion was made several years ago that although underground electrical transmission cables are very expensive, some economy might be achieved by cooling the electrical conductors to reduce resistive losses of electricity. If the cooling were achieved by pumping liquefied natural gas through the cable, a double economy could result since both electrical energy and natural gas fuel could be delivered (4-13). However, at LNG temperatures the electrical resistance of copper is reduced by only a factor of four. The reduction factor is ten at liquid nitrogen temperatures and two hundred to five hundred for liquid hydrogen temperatures, depending on the purity of the copper conductor.

Belanger and Jefferies (4-14) examined the potential of an underground electrical cable cooled by a cryogenic fluid. They chose liquid nitrogen rather than liquid hydrogen as the coolant for their studies. The advantages for liquid nitrogen are many. They include lower energy requirement for

liquefaction; higher heat of vaporization, better electrical insulator, less stringent thermal insulation requirements and fewer safety problems in handling. On the other hand, hydrogen further reduces the resistivity of the conductors. If the resistance is lowered by a factor of ten using nitrogen, however, 90 percent of the electrical losses are saved, and saving a portion of the remaining 10 percent cannot be justified economically by using liquid hydrogen.

The Edison Electric Institute is presently funding a major study of cryogenic underground cables (4-15, 4-16) which should provide the technological developments necessary to prove the system. While these studies use nitrogen, many of the construction problems will be similar for other cryogenic systems.

In cryogenic systems, it appears that the use of liquid hydrogen may compete with liquid nitrogen provided that the three following requirements are met:

- The electrical transmission line must be placed underground anyway. (For reasons such as right of way problems, aesthetics, environmental problems, etc.)
- The transmission line must be long enough and the capacity high enough so that significant losses in energy occur if the line is not cooled. (A 1000 MVA line may have losses of 20 percent in 250 miles. This is equivalent to \$1000/hr. or more in lost energy costs.)
- Gaseous hydrogen is available at one end of the line and liquid hydrogen is required at the other end. The requirement may be for peak-shaving or some other use but the use must bear the cost of liquefaction.

It must be emphasized that all three requirements must be present. If, for example, gaseous hydrogen is available at one end of the line and is to be used in the gaseous state at the other end, it is probably more economical at the present time to put a hydrogen gas pipe and a nitrogen cooled electrical cable side by side in the same right of way. The electrical cable cannot bear the cost of liquefaction of the hydrogen. As the concept is developed then large amounts of energy can be transferred in the energy pipe.

One recent development which improves the thermodynamics of liquid hydrogen transmission involves the use of "slush hydrogen" which is a mixture of up to 60 percent solid hydrogen in liquid. The latent heat of fusion as well as the heat capacity in raising the liquid temperature to the boiling point significantly increase the apparent heat capacity

of the system. Use of the slush hydrogen has been investigated by Minnic and Fox (4-17) and the properties of the mixture have been established. These properties are given in an article by Sindt (4-18). Efforts to develop this system for future use are recommended.

Related to the energy pipe concept is the superconducting cable which at the present time, uses liquid helium as the coolant. However, there are indications that superconducting alloys can be used at slush hydrogen temperatures with sufficient conduction capacity to be worthwhile. The three requirements previously listed would still have to be met for the system to be economical.

4.3.4 PEAK SHAVING FACILITY

As a basis for calculation we make the following assumptions:

- The annual energy demand in the area, which may be supplied in the form of hydrogen gas, is about 10^{15} Btu (10^{18} J).
- The hydrogen supply is by gas pipeline from a remote production site. The supply pipe line will deliver 3×10^{12} Btu/day (9×10^{11} J/s) when operating at full capacity -- 9.5 percent above average demand.
- A typical weekly demand curve is similar to that shown in Figure 4-2. This weekly demand curve is superposed on "average" annual demand curve shown in Figure 4-3. This latter curve is assumed to be relatively flat if most of the energy is for commercial and industrial use and only a small part for space heating.

NASA-S-73-2322

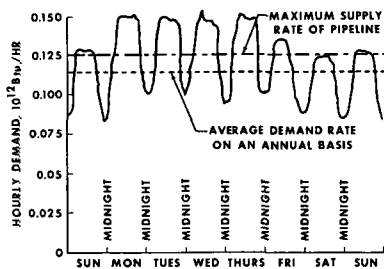

FIGURE 4-2
HOURLY HYDROGEN ENERGY DEMAND FOR
A TYPICAL FALL OR SPRING WEEK

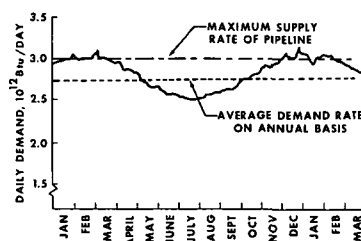

FIGURE 4-3
AVERAGE DAILY HYDROGEN ENERGY
DEMAND FOR A TYPICAL YEAR

- The price of energy in the form of hydrogen gas is $\$1/10^6$ Btu (One dollar per million Btu) which is equivalent to $\$1/10^9$ J. The economics of the system are not particularly dependent on this cost.
- No suitable underground gas storage such as aquifers or depleted gas fields is available nearby.

With these assumptions it is apparent that two types of peak-shaving must be provided: One, to take care of the rather wide variation in daily loads and the other to handle the seasonal swing. It will be noted that the oversizing of the pipeline can almost handle the seasonal variation. This is not the ideal situation and would not be used if an inexpensive means of storing gas for long periods were available. As will be seen in the calculations, however, liquefaction of hydrogen and subsequent storage of the liquid is not inexpensive. A third consideration should probably be included: the possibility of pipeline failure. Repairs in such a situation could probably be accomplished in a few days. If a three or four day supply of hydrogen were stored on a more or less permanent basis it would provide an emergency reserve for the entire system.

It should be possible to combine the emergency reserve with the peaks on the annual curve in Figure 4-3. If these peaks are not too far above the maximum rate of supply and do not last for too long, they actually do not compromise the reserve capacity of the system. The total area above the maximum supply line in a "typical" winter is less than one total daily supply. Thus we will make a further assumption.

- A nominal four day supply of hydrogen will be kept in liquid storage for safety and handling the peaks on the annual curve due to extreme weather. This supply will be replenished during low energy demand periods.

It is also apparent that daily demands which are above the maximum supply rate cannot be supplied unless additional storage facilities are provided. The actual quantity which must be stored is not large, but could be equivalent to a three or four day supply during the winter. However, the liquefaction capacity must be greatly increased to account for the normal, short term, cycle. From Figure 4-2 it is apparent that during the fall or spring when the average demand is near the maximum supply, the peak demands are significantly greater. Thus, a rather sizable liquefaction capacity must be constructed but it need be operated only on an intermittent basis. This will add significantly to the total peak-shaving cost; unfortunately there appears to be no logical solution to this dilemma. Fortunately, very little added storage capacity is required since it is filled and emptied on nearly a daily basis. One final assumption will consequently be made.

- A one day supply of liquid hydrogen must be stored for daily variations but sufficient liquefaction capacity must be maintained to reliquefy this amount during any seven day period when gas is available.

Reviewing the assumptions, it appears that the storage requirements are about eight average days, which is equivalent to 2.2×10^{13} Btu (2.3×10^{16} J). The liquefaction capacity is rather large and is mainly controlled by assumption seven. If this amount of capacity is installed then by proper scheduling of operation it will be able to fill all storage in an eight week period during the summer. This means that the capacity of the liquefier should be about 3.9×10^{11} Btu/day (1.14×10^{11} J/s), which is nearly 15 percent of the average daily demand.

Admittedly, an eight day supply in addition to the 9.5 percent over supply capacity is rather large for the ideal assumptions we have made, but the attempt here has been to be conservative. If the situation should improve to where reliability of transmission is assured, then storage capacity could be reduced. An estimate of the costs for this size liquefaction and storage capacity may be obtained from a study made by N. C. Hallett (4-19). He indicates that storage in large, vacuum perlite insulated tanks can probably be made to hold ten to twelve million gallons each. In this size the losses due to boil-off will be about .015 percent per day and will be reliquefied. Thus, characteristics of the storage system are:

Total liquid hydrogen storage capacity = 427×10^{13} Btu (2.3×10^{16} J)

Mass of liquid hydrogen stored = 427×10^6 lb. (939×10^6 Kg)

Capital cost of storage tanks = $\$427 \times 10^6$

Boil-off = 64,000 lb/day
(140,800 Kg/day)

The liquefier capacity must be 7.6×10^6 lb/day (1.67×10^7 Kg/day) to satisfy the previous assumptions. Fuel for this plant capacity will cost over \$114,000/day of operation if hydrogen at $\$1/10^6$ Btu ($\$1/10^9$ J) is used. However, assuming 20 weeks of operation, mostly during the summer, the annual fuel cost will be about \$16,000,000.

Again, from Hallett, the plant capacity could be built for a capital investment of \$580,000,000 and operating costs in addition to the fuel costs would be about \$25,000,000 (4-19). Assuming that operating costs of the tank farm are negligible the final totals are as follows:

Capital cost, liquefier	\$ 580,000,000
Capital cost, storage	<u>427,000,000</u>
Total Capital	\$1,007,000,000
Liquefier fuel cost	16,000,000
Plant operating costs	<u>25,000,000</u>
Annual variable costs	\$ 41,000,000

Assuming 12 percent investment charge and 20 year life, the equivalent annual cost is \$176,000,000 of which \$135,000,000 is investment charge.

While this seems at first glance like an excessive cost, it must be compared to the value of the fuel handled to bring it into perspective. Remember that it was assumed that the system handled 10^{15} Btu/year (10^{18} J/year). At a wholesale cost of $\$1/10^6$ Btu ($\$1/10^9$ J) this fuel has a value of one billion dollars. Thus we have increased the cost by only 18 percent in order to improve system reliability and handle a variable load demand.

This size facility would require 60 of the largest proposed tanks, (12,000,000 gal. ($45,420 \text{ m}^3$) each), and the liquefaction capacity would probably be split among two or more plants.

4.3.5 THE SMALL TOWN

The small town which is not located along the route of a gas line represents an area where liquid hydrogen might play an important role in supplying local energy needs. The economics of this situation are entirely different from those of the peak-shaving plant described in the previous section. A hypothetical example will be eval-

uated which may illustrate the basic considerations.

Future energy predictions indicate that energy use may increase to about 900,000 Btu (10^9 J) per capita per day. A small town of about 5,000 population, some regional commerce and a little light industry might consume 4×10^9 Btu/day (4.2×10^{12} J/day). It will be assumed as a calculation base that about half of this energy can be supplied by hydrogen. In order to make representative calculation the following arbitrary assumptions will be made.

- The community is located 250 miles (4×10^5 m) from an industrial center which has liquefaction plants and liquid storage for peak-shaving.
- Seasonal variations may be ignored since the rate of supply from the industrial center may be adjusted.
- A one week supply will be kept on hand to offset equipment failure or other difficulties in delivery.
- The hydrogen will be delivered as a liquid, stored as a liquid and gasified for use.

Storage capacity at the town would be about 14×10^9 Btu (14×10^{12} J). This is about 470,000 gallons (1780 m^3) or 272,000 lb. ($124,000 \text{ Kg}$) of hydrogen. A storage tank of this capacity is well within present capability. Lower cost insulation can be used since continual gasification of the supply liquid will be required. In fact, a boil-off rate of several percent per day would be acceptable. With such a high boil-off rate a relatively inexpensive tank using internal foam plastic insulation with a hydrogen barrier liner would probably be suitable. The cost of large tanks of this type would probably be less than half that of tanks discussed in the previous section. In the size needed here, however, the cost of the simpler tank will still probably be about \$1/lb. (\$.45/kg) of hydrogen capacity. Extrapolating from calculations made by Hallet (4-19) the following numbers are representative.

Storage capacity:	272,000 lb (598,400 Kg)
Capital cost:	\$300,000
Annual operating cost:	\$ 10,000/year

The boil-off of 5 percent per day equals 7×10^8 Btu/day (7×10^{11} J/day). In addition, to supply the average daily demand twice this heat transfer will be needed to vaporize the liquid hydrogen.

The cost of transporting the liquid hydrogen from the liquefaction plant to the

town is more difficult to determine. Both truck and rail tankers will be considered in an effort to cover the possibilities. Some improvement in present systems will be assumed but these will be relatively minor.

When transporting liquid hydrogen by tanker, size rather than weight, is the limiting factor. This is true because of the low density of liquid hydrogen. Regulations controlling tank truck size set the maximum net cargo at about 13,000 gallons (49 m^3). Some improvement may be possible by redesign of the tankers but unless size limits are changed it appears that 15,000 gallons (57 m^3) is a reasonable upper limit. With this size tanker an average of about 31 deliveries per week are needed. If the shape of the seasonal demand curve is similar to that shown in Figure 4-3, the peak delivery rate would be about 35 deliveries per week, and the minimum about 28.

For a round trip of 500 miles (8×10^5 m) the actual time on the road will probably be 14 to 16 hours. If multiple crews are used and loading and unloading are handled by other than the drivers, it is conceivable that each tanker could complete one trip every 24 hours. However, maintenance, trip scheduling and questions of reliability dictate that the number of tankers should be greater than five. If several such systems are served by one center and if the tankers are interchangeable then a 20 percent over capacity may provide an adequate safety margin. This means that the system being considered would be charged with six tankers, each of 15,000 gallon (57 m^3) capacity.

A reasonable estimate of the cost of these tankers is \$100,000 per unit. Operating costs of 50¢ per mile (.03¢/m) would probably be typical and a crew of four men would be the minimum which could keep a truck operating. The system costs for truck transportation would therefore be the following:

Capital investment:	\$600,000
Operating cost:	\$450,000/yr.
Crew for 6 trucks:	\$600,000/yr.

If the trucks are amortized on a ten year basis at 12 percent the equivalent annual cost for the transportation system is \$1,156,000. This is a relatively large cost and adds $\$1.58/10^6$ Btu ($\$1.50/10^9$ J) to the cost of hydrogen fuel.

An alternative method of supply is by rail tanker rather than highway tanker. The capital costs increase since more tank car capacity would be required in order to properly schedule shipment and return, but operating costs should be reduced. If rail tank cars of 25,000 gallon (95 m^3) capacity can be built -- and this seems reasonable -- then only 19 cars per week, on the average,

will be required and 21 per week during peak demand. If 2 shipments per week can be made then 12 tank cars should be adequate allowing as before for an emergency reserve. It is estimated that these cars will have a unit cost of \$150,000, for a total capital cost of \$1,800,000. Operating costs will be lower and in general will be a part of the freight rates.

In trying to arrive at a reasonable hauling cost for future shipments of liquid hydrogen we have based the estimates on the assumption that such shipments will be routine and will be charged at relatively low bulk rates. One cent per ton-mile (0.08¢/kmg) is probably in the proper range provided that the gross car weight is used for the round trip. A tank car holding 25,000 gallons (95 m³) of liquid hydrogen will probably weigh 80 to 100 tons (3.52 x 10⁵ to 4.4 x 10⁵ kg) empty while the hydrogen weighs only 725 tons (3.19 x 10⁶ kg). Thus a round trip of 500 miles (8 x 10⁵ m) at one cent per ton mile (0.08¢/kmg) would cost about \$500 per tank car load. One thousand tanks per year will thus result in an annual transportation cost of \$500,000. If the capital costs are amortized on a ten year basis at 12 percent, the equivalent annual transportation cost for rail shipment will be about \$820,000. Although this is much less than truck transport it requires that the town be located on a rail line.

In order to complete the economic analysis, the liquefaction costs as well as the cost of the gas liquefied must be included. In the previous section we considered a plant used for peak-shaving. If the capacity is increased slightly, such a plant could supply liquid for a small town at the incremental cost. The equivalent annual cost for only the liquefier in the previous section was about \$119,000,000 for an assumed twenty weeks of operation during which hydrogen with a heating value of 5.5 x 10¹³ Btu (5.8 x 10¹⁶ J) was liquefied. The cost of liquefying can then be taken as \$2.16/10⁶ Btu (\$2.04/10⁹ J) and the cost of the gas liquefied is assumed to be \$1/10⁶ Btu (\$1/10⁹ J). If the liquefaction plant charges \$3.50/10⁶ Btu (\$3.32/10⁹ J) for liquid hydrogen it should recover the cost of the gas, the liquefaction process, and receive a fair handling charge in return.

The cost of obtaining energy in the small town in the form of hydrogen is thus comparatively high. The cost breakdown is as follows:

Cost of liquid hydrogen:
 \$3.50/10⁶ Btu (\$3.32/10⁹ J)
 Cost of rail transport:
 \$1.12/10⁶ Btu (\$1.06/10⁹ J)

Cost of terminal:
 \$.19/10⁶ Btu (\$.18/10⁹ J)
 Total
 \$4.81/10⁶ Btu (\$4.56/10⁹ J)

Cost of liquid hydrogen:
 \$3.50/10⁶ Btu (\$3.32/10⁹ J)

Cost of highway transport:
 \$1.58/10⁶ Btu (1.50/10⁹ J)

Cost of terminal:
 \$.19/10⁶ Btu (\$.18/10⁹ J)
 Total
 \$5.27/10⁶ Btu (\$5.00/10⁹ J)

To evaluate these numbers they must be compared with the costs of other forms of energy or other means of hydrogen delivery.

While it is difficult to find any data on the cost of building small pipelines it is not difficult to see that the cost would have to be very high to equal the system cost of the liquid hydrogen transport case. For example, assuming construction costs of \$25,000 per mile (\$15.5/m) plus one pumping station at \$100,000, would result in a capital investment of \$6,350,000 (4-26). For a twenty year amortization and 12 percent interest, the equivalent annual cost is \$851,000 which adds \$1.15/10⁶ Btu (\$1.09/10⁹ J) for delivery of gas. While no system operating costs have been added it is apparent that the cost of energy with the gas system will never exceed the costs using the liquid delivery.

It must be emphasized that the cost of liquefaction makes the system uneconomical, not the cost of transporting the liquid. Thus, the use of low cost transportation schemes -- barges, airships, supertanker planes, or dirigibles -- will not make the system economically competitive with the gas pipeline; the cost of liquefaction must be drastically reduced for the transportation costs to have much influence.

4.4 SOLID HYDRIDES

4.4.1 MECHANISM OF STORAGE

Metal hydrides have been proposed by two groups of investigators as a method of storing hydrogen; at the Brookhaven National Laboratories (4-21) and another at the Phillips Laboratory in the Netherlands (4-22).

Hydrides are metal-hydrogen compounds that have certain attributes that make them advantageous for storage of hydrogen. Unfortunately, there are also deficiencies that make hydrides unsuitable for certain types of hydrogen storage systems.

The hydride storage systems operate in the following manner. Hydrogen under pressure is pumped into a container filled with a suitable metal or alloy which absorbs hydrogen and ultimately forms a metal hydride compound. Since all of the useful metal-hydrogen compounds for storage are exothermic in nature, the formation of the metal hydride is accompanied by the release of the heat of formation. This heat must be removed from the system or the hydride forming reaction will stop and hydrogen will cease to be stored; an important point to remember when hydrides are proposed for practical applications, such as automotive fuel tanks. Each of the metal hydride systems will absorb hydrogen up to an equilibrium pressure called the dissociation pressure. The dissociation pressure depends mainly on temperature and the nature of the metal (4-23).

When the hydride is reheated, such as with waste heat from an engine, the hydrogen gas is evolved and builds to the equilibrium pressure inside the container. If gas is removed from the system the pressure is lowered and more hydride decomposes.

4.4.2 ADVANTAGES AND DISADVANTAGES OF HYDRIDE STORAGE

Probably the most interesting and useful advantage of hydrides is that hydrogen gas can be stored in solid form at room temperature at a volume density equal to or greater than liquid hydrogen. In addition, hydrogen can be released for use in an easily controlled manner. The hydride storage system has a great advantage over liquid hydrogen storage from the safety standpoint. Liquid hydrogen storage requires elaborate safety precautions, sophisticated containers, and specially trained personnel. Hydride systems do not appear to need comparable safety measures and only low pressure tanks are required. An important safety aspect of hydride storage is the endothermic behavior during the release of the hydrogen gas from the hydride. In practical terms what this means is that if the pressurized tank is punctured and gas starts to escape the temperature is decreased and the dissociation reaction is stopped. A possible unsafe factor of hydrides is the pyrophoric nature of some fine powdered metals. Summing up the advantages, it appears that hydrides offer a relatively safe, reliable, and possibly portable system for the storage and use of hydrogen.

Because the hydrogen is combining with metal elements that are of comparatively high

atomic weight the energy per unit weight of the hydrides is low. In most cases the weight of the hydride will be from five to 50 times greater than the weight of hydrogen that is stored. This is shown in Table 4-2 for the hydrides considered by Wiswall and Reilly (4-23) for hydrogen storage. These figures indicate one of the major disadvantages of hydrides; they are all low mass energy density sources compared to conventional fuels.

TABLE 4-2
PERCENTAGES OF HYDROGEN IN VARIOUS
METAL-HYDROGEN SYSTEMS

Hydride	% Hydrogen By Weight	Weight of Hydride Weight of Hydrogen
FeTiH	0.95	104
VH ₂	3.7	26
Mg ₂ NiH _{4.2}	3.7	26
MgH ₂	7.6	13
KH	2.5	40
UH ₃	1.2	80
ZrH ₂	2.1	47
CaH ₂	4.7	21
LiH	12.6	8
CeH ₂	1.4	71

One other disadvantage of the hydrides is that as a class of materials they are highly reactive and contamination is likely to occur from impurities in the hydrogen. The extended use of hydrides for storage will require additional filtering or processing to remove undesirable contaminants.

4.4.3 ECONOMICS

There are two factors in the manufacturing economics of using hydrides for hydrogen storage. One is the cost of the metal needed to store the hydrogen and the other is the large amount of metal for large scale, general storage such as the small town example given in section 4.3.5.

Most metal-hydrogen systems will employ high purity powdered metals that are not likely to decrease in cost below \$0.25 per pound even with large-scale use of common metals such as iron or magnesium. In the case of the rare earth metals the cost will probably exceed \$2.00 per pound.

For the small town example (Section 4.3.5), 272,000 pounds (124,000kg) of hydro-

gen storage are required. At a highly optimistic value of 10 percent hydrogen in the hydride, we would need 2.7×10^6 pounds (1.23×10^6 Kg) of hydride or approximately 2.4×10^6 (1.1×10^6 Kg) pounds of metal. At the lowest price for metal this represents a sizable capital investment.

Assuming a \$10,000 operating cost and 20 year amortization, the equivalent annual cost for hydrogen stored varies from \$6.50/ 10^6 (\$6.5/ 10^9 J) to \$46/ 10^6 Btu depending on the metal costs per pound. The equivalent annual cost for the comparable small town liquid hydrogen storage would be \$3.60/ 10^6 Btu (\$3.60/ 10^9 J).

It is concluded that under the most optimistic conditions hydride storage for small-scale general conditions will not be able to compete with liquid hydrogen storage. If we consider 10,000 towns in the United States that could use storage by the hydride method this means that approximately 25×10^9 (112×10^9 Kg) pounds of metal would be required. This figure exceeds the total world production of many of the elements listed in Table 4-2.

It appears from the two considerations above that generalized hydride storage will be limited to small scale, specialized types of storage unless metal-hydrogen systems based on abundant, cheap metals are found.

4.5 CONCLUSIONS

The use of hydrogen, either as gas or liquid, as a primary fuel will necessitate the development of large-scale transmission and storage systems.

A hydrogen gas pipeline system similar to the existing natural gas pipeline system appears to be the most practical solution. The pipeline system must be capable of delivering hydrogen gas directly from the generating plant to the user. It will be necessary to provide some storage capacity to meet both daily and seasonal peak-shaving requirements. Daily needs may be economically satisfied by line pack storage. Seasonal peak-shaving requirements may be satisfied most economically by large scale underground storage in depleted natural gas fields, aquifers, or other suitable natural formations. More costly peak-shaving storage may also be accomplished by high pressure tanks, liquid hydrogen reservoirs, and gas storage in mined caverns.

It is expected that a hydrogen pipeline system can be implemented using present day technology. Some research will be needed to establish specific design criteria for various portions of this system. Particular attention should be given to the question of hydrogen environment embrittlement of pipeline metals. It will also be necessary to

examine the feasibility of converting portions of the existing natural gas to hydrogen transport. It appears that conversion of present pipelines can be accomplished; however, one can expect a number of problems.

The projected cost of hydrogen gas transmission is somewhat higher than natural gas transmission but will be significantly less than overhead electrical transmission. It will be economical to transmit large quantities of energy through a hydrogen system. The cost of hydrogen generation will affect the overall economy of a hydrogen energy system more than the cost of transmission and storage of hydrogen gas.

The liquefaction of hydrogen is costly although the required technology has been developed for some time. The expense arises from two facts: the process requires a great deal of energy, and the process involves very complicated, and hence expensive, equipment. In addition, if storage of the liquid is required, the storage tank cost must also be added to the cost of liquefaction.

As a result of these costs it is apparent that hydrogen will be transported and stored as a liquid only if there is no alternative. One such area of use may be the storage of energy for peak-shaving in a large power system where suitable gas storage facilities are not available.

If the hydrogen must be liquefied for some other purpose, such as peak-shaving, then the cryogenic properties of the liquid may be useful for other purposes. One potential use is the cooling of underground electrical cables to eliminate the resistive power losses. Such cables could not compete with present overhead cables but they may have sufficient environmental and aesthetic advantages to be justified in the future.

Hydrides have some useful and advantageous properties when compared with gaseous and liquid hydrogen, particularly considering volume energy density. Even though the gas is stored at densities greater than liquid hydrogen in hydride usage there are no associated liquefaction and cryogenic storage problems. However, even with this decided advantage over liquid hydrogen storage, it appears that hydrides as fuel storers will be limited to small scale specific uses rather than to large scale general uses. The reasons for this are the poor mass energy densities and the probable excessive costs of metals. In addition, large-scale general storage will involve significant amounts of the world production of many of the metals used to make hydrides.

It appears there are no insurmountable technological or economical barriers to the transmission and storage of hydrogen either as a gas or a liquid in a hydrogen economy.

Additional costs of safety, and environmental and social impacts will probably be no greater than those involved with present natural gas transmission and storage systems.

SELECTED REFERENCES

- 4- 1 "U.S. Energy Outlook: A Summary Report of the National Petroleum Council", National Petroleum Council, p. 29, December, 1972.
- 4- 2 American Gas Association, 1971 Gas Facts: A Statistical Record of the Gas Utility Industry in 1970, Arlington, Va., 1972.
- 4- 3 Segeler, C. G. Ed., Gas Engineers Handbook, The Industrial Press, 1965.
- 4- 4 Gregory, D. P., "A Hydrogen-Energy System", Report No. L21173, Inst. of Gas Technology, August, 1972.
- 4- 5 Reynolds, R. A. and Slager, W. L., "Transportation and Storage of Hydrogen for Eco-Energy", GE72TMP-54, General Electric Company, December, 1972.
- 4- 6 Hausz, W., Leeth, G., Lueck, D., and Meyer, C., "Hydrogen Systems for Electric Energy", 72TMP-15, General Electric Company, 1972.
- 4- 7 Seibel, C. W., Helium, Child of the Sun, The University Press of Kansas, 1968.
- 4- 8 Walter, R. J. and Chandler, W. T., "Effects of High Pressure Hydrogen on Metals at Ambient Temperature", Report No. N70-18637, Rocketdyne, Canoga Park, California, February 28, 1969.
- 4- 9 Jewett, R. P. et al, "Hydrogen Environment Embrittlement of Metals", NASA CR-2163, March, 1973.
- 4-10 Gray, H. R., "Hydrogen Environment Embrittlement", NASA TM X-68088, Lewis Research Center, Cleveland, Ohio, 1972.
- 4-11 Barron, R., Cryogenic Systems, McGraw-Hill Book Co., p. 60-63 and p. 118-120, 1966.
- 4-12 Commander, J. C. and Ratter, L., "An Economic Analysis of Perlite Versus Super Insulation in Liquid Hydrogen Storage Vessels", NASA CR-54720, October, 1965.
- 4-13 Pastuhor, A. and Ruccia, F., "Total Energy Transfer System for LNG and Electrical Power", Cryogenics and Industrial Gases, V. 4, n. 3, p. 14-18, March, 1969.
- 4-14 Belanger, B. C., and Jefferies, M. J., "Cryogenic Power Cable: Design and Test", Cryogenics and Industrial Gases, V. 7, n. 2, pp. 15-22, March-April, 1972.
- 4-15 "Super Conductive Underground Electrical Transmission: One Step Closer", Cryogenics and Industrial Gases, V. 4, n. 7, p. 22-24, July, 1969.
- 4-16 "Lab Spurs Cable R & D", Cryogenics and Industrial Gases, V. 8, n. 1, p. 29, January-February, 1973.
- 4-17 Minnic, S. and Fox, G. R., "Cryogenic Power Transmission", Cryogenics, V. 9, n. 3, p. 1965, June, 1969.
- 4-18 Sindt, C., "A Summary of the Characterization Study of Slush Hydrogen", Cryogenics, V. 10, n. 4, p. 372, October, 1970.
- 4-19 Hallet, N. C., "Study, Cost and System Analysis of Liquid Hydrogen", NASA CR 73-226, June, 1968.
- 4-20 "Pipeline Economics", The Oil and Gas Journal, V. 69, n. 31, August 2, 1971
- 4-21 Hoffman, K. C. et al, "Metal Hydrides as a Source of Fuel for Vehicular Propulsion", paper SAE 690232 presented at the International Automotive Engineering Conference, Detroit, January 13-17, 1969.
- 4-22 van Vucht, J. H. N., et al, "Reversible Room Temperature Absorption of Large Quantities of Hydrogen by Intermetallic Compounds", Phillips Research Reports 25, 133-40. Eindhoven, The Netherlands: Phillips Research Laboratories, April, 1970.
- 4-23 Wiswell, R. H. Jr. and Reilly, J. J., "Metal Hydrides for Energy Storage". Proceedings of 7th Intersociety Energy Conversion Eng. Conf. 1972, San Diego, Calif., Sept. 25-29, 1972.

ORIGINAL PAGE IS
OF POOR QUALITY

N74-11733

CHAPTER 5

USAGE OF HYDROGEN

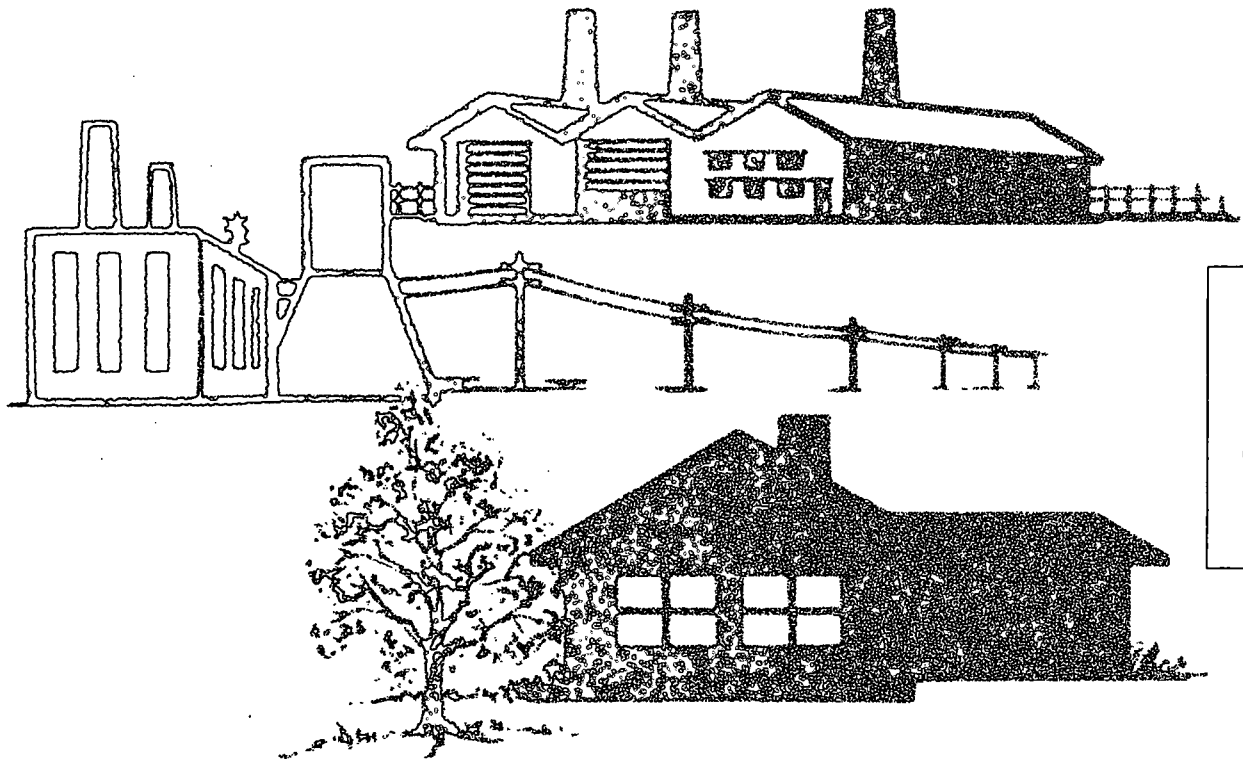

5

ORIGINAL PAGE IS
OF POOR QUALITY

5.1 INTRODUCTION

5.1.1 USAGE OF ENERGY

The energy contained in a fuel, of whatever form, is of no value unless it can be put to some use helpful to mankind. An examination of the energy situation must then take careful note of the ways in which this is accomplished. Fossil fuels presently serve not only as the energy source, but also as the carrier by which energy is distributed to the point of conversion to useful work. This situation partially explains the preference for fossil fuels. Thus, any study of the energy system must also include a consideration of the source, the carrier, and the conversion processes. This chapter is an analysis of possible uses of hydrogen in these conversion processes.

The present method of obtaining most of the energy is the burning of various fossil fuels: coal, natural gas and liquid hydrocarbons. These fuels are available in some limited quantity and

their formation rates are much less than present usage rates. As the supply of these traditional fuels decreases, their value, as both a fuel and a raw material, increases. Thus, these sources must be consumed at a decreased rate or alternate energy forms must be discovered.

In this study, emphasis has been placed on minimizing the use of fossil fuels, while meeting reasonable energy demands of our society. Due to the many and complex uses of energy, a careful study was made of the several different areas of the entire energy picture. The demand for energy involves a study of the forms of work and a forecast of the quantities required for each form. Also included is a plan to implement the conversion from present fuels to hydrogen, with a careful consideration being given to the impact of the conversion on society and the environment.

The existing energy system presents, of necessity, a complex picture; partially characterized by the detail of Figure 5-1.

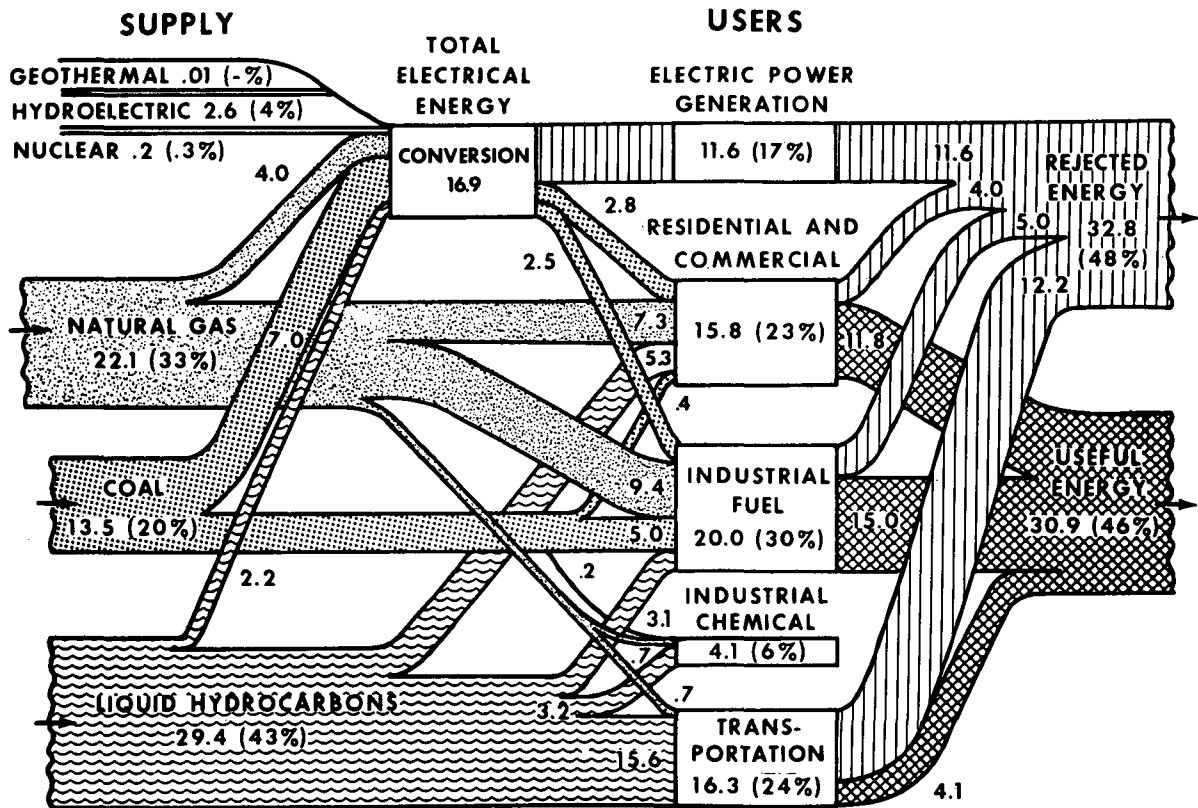

(ALL VALUES ARE $\times 10^{15}$ BTU - TOTAL U.S. DEMAND 67.8×10^{15} BTU)

FIGURE 5-1
U.S. ENERGY DEMAND PATTERNS, 1970

The primary sources are, for the most part, processed to convert them to a form which is more adaptable to available transportation, storage facilities, or use facilities. The usage of fuel may be classified into four different forms:

- open burning for thermal or heating use
- external-combustion for eventual conversion to shaft power
- internal combustion for shaft power
- consumption as a chemical raw material.

Conversion devices of many different types use these forms to perform a variety of tasks.

5.1.2 DEMAND FOR ENERGY

Energy consumption in the United States has increased tremendously in the past. A total of 68×10^{15} (68 Q) Btu was used in 1970. This astronomical amount of energy is better visualized if it is converted to an equivalent amount of oil per day. The use of 68 Q of energy is equal to 33 million barrels of oil per day, or the equivalent volume of water that passes over Niagara Falls in 15 minutes. The average per capita energy use in the United States is the equivalent of seven gallons of oil per day.

The increasing use of energy is related to a number of factors, but the major force has been the relatively low cost of the energy sources. This has led to the manufacture and use of numerous comfort and convenience devices. Some of these, such as appliances and the automobile, have become a vital necessity to our way of life.

Forecasts of the future energy demands have been made by various groups and authors (5-1 through 5-15) using a variety of techniques. Most of these forecasts have, however, been based in some fashion on historical growth patterns. The resulting forecasts, thusly, do not admit to any limits to the amount of energy consumed by the individual each day. If, however, some limit does exist, the forecast must account for this limit which may be called an energy saturation limit. It is contended here that such a limit does indeed exist.

The saturation concept reflects the inability of an individual to physically utilize more than a certain amount of energy due to time and spatial constraints. The time restraint implies that each person does, within each day a number of activities, each having the use of energy con-

nected with it. Although this individual has the option to select among the activities, only a few may be engaged in at one time. Some of the activities are: sleeping, eating, working, driving and various forms of recreation. The second aspect of this concept is the spatial restraint; each individual has a limited amount of space, which is necessary and sufficient for a selected activity. Thus, an individual can engage in an activity only as limited by space and time. Then, even if conditions are ideal so as to maximize the use of energy, only a limited amount can be expended. By forecasting the time, and space required for activities, maximum energy usage per capita (saturation) may be established.

A simplified example of saturation is the use of television. Due to their required activities, the maximum possible viewing time is approximately 16 hours per day per person. The space required for this viewing is likewise limited. By evaluating the total energy requirements of the television set and optimum conditioning of the space, a saturation limit is set for these 16 hours of the day.

Some of the areas of energy consumption are not directly related to personal habits and thus, not forecastable by the saturation concept. In these areas more conventional forecasting techniques were used. Gross national product, population and historical growth rates have in the past been good indicators of energy consumption for certain segments of the economy. Forecasts of these indicators, with modification to account for saturation, were then used in projecting demand.

The total energy demand forecasts were obtained by the 'building block' or composition forecasting method. This required the forecasting of demand for different individual use areas. In these various areas, the forecast was based on the saturation concept with population growth considered, conventional forecasting or a combination of both to project total demand. Saturation forecasting is not applicable to all use areas due to anticipated continued growth, thus the average energy use per capita will continue to increase in the future.

Future demand requirements were then combined to form the projections for the common user areas, these being:

- residential and commercial
- industrial-fuel
- transportation
- electric power generation
- industrial-chemical

The forecasted demands under the concept of

**ORIGINAL PAGE IS
OF POOR QUALITY**

saturation and unrestricted growth are shown in Figure 5-2.

forecast shown in Figure 5-3 includes the effect of realistic measures that can be expected to materialize in the future.

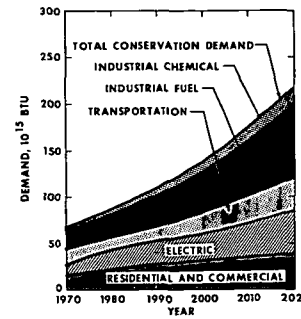
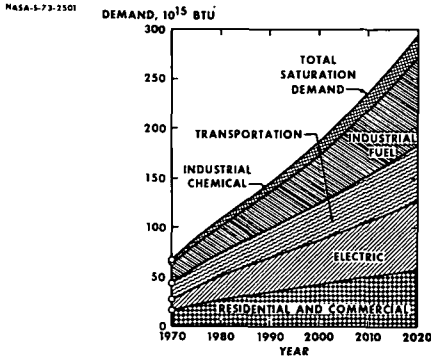

**FIGURE 5-2
TOTAL SATURATION DEMAND
BY AREA, 1970-2020**

**FIGURE 5-3
TOTAL CONSERVATION DEMAND
BY AREA, 1970-2020**

A realistic view of the energy saturation in the United States would seem to indicate that energy conservation will become a necessity as fuel scarcity becomes a reality. A number of studies have been made of various conservation techniques and efforts (5-2, 5-3, 5-4, 5-9, 5-10, 5-11, 5-13, 5-16). The effect on saturation forecasts of these conservation measures were analyzed. The conservation

The saturation and conservation demand projections are tabulated in Tables 5-1 and 5-2, respectively. Table 5-3 presents projected population and energy use per capita.

**TABLE 5-1
TOTAL SATURATION DEMAND BY AREA, 1970-2020
(VALUE IN 10^{15} BTU)**

	<u>1970</u>	<u>1980</u>	<u>1990</u>	<u>2000</u>	<u>2010</u>	<u>2020</u>
Residential Commercial	15.8	26.7	34.5	42.0	49.5	58.0
Industrial Fuel	20.0	26.9	36.1	48.5	65.2	87.7
Electric Power Generation	11.6	25.3	35.7	45.3	56.0	67.0
Transportation	16.3	22.1	29.0	38.5	47.1	57.7
Industrial Chemical	<u>4.1</u>	<u>7.0</u>	<u>9.9</u>	<u>13.2</u>	<u>17.8</u>	<u>23.9</u>
Total	<u>67.8</u>	<u>108.0</u>	<u>145.2</u>	<u>187.5</u>	<u>235.6</u>	<u>294.3</u>

TABLE 5-2
TOTAL CONSERVATION DEMAND BY AREA, 1970-2020
(VALUES IN 10¹⁵ BTU)

	<u>1970</u>	<u>1980</u>	<u>1990</u>	<u>2000</u>	<u>2010</u>	<u>2020</u>
Residential Commercial	15.8	22.1	26.1	30.2	34.7	39.4
Industrial Fuel	20.0	24.2	32.5	43.6	58.7	78.9
Electric Power Generation	11.6	20.1	25.6	31.3	38.0	45.0
Transportation	15.3	14.1	16.8	22.5	28.1	36.0
Industrial Chemical	<u>4.1</u>	<u>6.9</u>	<u>9.2</u>	<u>11.8</u>	<u>18.2</u>	<u>19.5</u>
Total	<u>67.8</u>	<u>87.4</u>	<u>110.2</u>	<u>139.4</u>	<u>176.7</u>	<u>218.8</u>

TABLE 5-3
POPULATION AND DEMAND PER CAPITA, 1970-2020

	<u>1970</u>	<u>1980</u>	<u>1990</u>	<u>2000</u>	<u>2010</u>	<u>2020</u>
Population (millions)	200	221	248	270	298	328
Saturation Demand/capita (10 ⁶ Btu)	338	490	586	695	792	897
Conservation Demand/capita (10 ⁶ Btu)	338	396	445	518	594	667

5.2 HYDROGEN UTILIZATION DEVICES



5.2.1 WATER MODIFIED H₂-O₂ (APHODID) BURNER

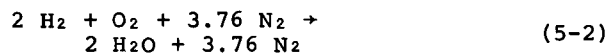

When a hydrogen combustion process incorporates the use of oxygen rather than air as the oxidizer, no nitrogen compounds or other undesirable gases will be present in the exhaust. Equation 5-1 represents the theoretical hydrogen-oxygen reaction to water vapor products, while equation 5-2 illustrates the same reaction with air.

Note that in the H₂ - air reaction 3.76 moles of nitrogen are involved with the reaction but do not contribute to that reaction. In fact, since the nitrogen is in contact with the burning hydrogen-oxygen mixture it absorbs a portion of the combustion energy which results in a lower theoretical flame temperature for the overall mixture. The accepted value of theo-

retical flame temperature for the reaction shown in equation 5-1 is 3080°K, while that for equation 5-2 is 2400°K.

If equation 5-2 is written so as to include excess air, the following equation can result

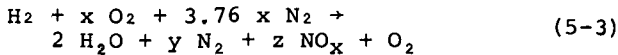

Note here that at the reaction temperature at least part of the excess oxygen has reacted with the excess nitrogen to form various oxides of nitrogen (NO_x). The NO_x products can later combine with hydrocarbons and sunlight in an urban environment to form photochemical smog.

In addition to the undesirable polluting effect of the reaction shown in equation 5-3, the additional quantity of products drives the combustion temperature still lower.

Thermodynamically, the maximum possible efficiency of a heat engine is represented by the Carnot cycle efficiency

$$\eta = \frac{T_H - T_L}{T_H} \quad (5-4)$$

where T_H represents the temperature of heat supply (combustion) to the engine and T_L represents the temperature of heat rejection from the engine. This relationship illustrates that as the combustion temperature of an engine is reduced the theoretical efficiency will also be reduced.

Obviously, the reaction represented by equation 5-1 is preferable to those of equations 5-2 or 5-3, since the engine operating with this reaction (equation 5-1) would not only tend to be more efficient but also would be nonpolluting.

The aphodid burner (see Figure 5-4) is a device that uses hydrogen and oxygen

as in equation 5-1 to produce high temperature steam that can later be used by any one of several types of steam engines or processes (5-17). This burner also uses an additional water input to lower the combustor exit temperature to metallurgically acceptable values.

Ideally the water spray could be eliminated and the resulting reaction (equation 5-1) would produce the theoretical flame temperature of 3080°K. This temperature would in turn produce a Carnot cycle efficiency of

$$\eta = \frac{(3080 - 294)(100)}{3080} = 90\% \quad (5-5)$$

if the heat rejection temperature is taken to be T_L = 294°K. This efficiency then becomes the limiting efficiency in a cycle using an aphodid burner.

Assuming a water spray input to reduce aphodid burner outlet temperature to 2480°K, in a steam turbine which uses cooled turbine blades capable of withstanding these combustion gas temperatures, and assuming reasonable mechanical and electrical efficiencies, an overall cycle efficiency of 60 percent seems likely. In fact, efficiencies of up to 70 percent have been predicted by the General Electric Corporation (5-18).

Present steam power plants use fossil fuels and air at combustion temperatures of about 1875°K to produce steam in a heat exchanger at an approximate temperature of 860°K. The resulting efficiency for such a modern plant operation under these conditions will be approximately 44 percent. This cycle efficiency is not expected to increase significantly as long as the present type of boiler is used.

The same type of plant, however, using an aphodid burner operating on hydrogen and oxygen should be able to increase this efficiency by sixteen percentage points to 60 percent, or an increase of 36 percent over a similar fossil fueled plant.

In power plant type applications the aphodid burner actually takes the place of the conventional boiler. Its greatest advantage however, is its smaller size. Studies at Rockwell International indicate that this burner may replace boilers that are 500 times larger in physical size (5-19). They estimate that the aphodid burner will be smaller than an average living room while a comparable fossil fuel boiler would be nearly as large as a six story building.

Conventional power plants emit many or all of the following atmospheric contaminants depending on the type of fuel used; ash, soot, carbon dioxide, carbon monoxide,

NASA-573-2466

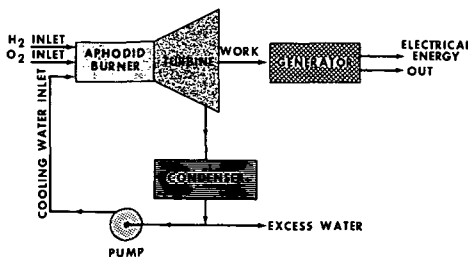

FIGURE 5-4
APHODID BURNER STEAM POWER PLANT

sulphur dioxide, nitrogen oxides, water vapor, and others. An aphodid burner plant in contrast would emit only pure water and this would probably be in the liquid form that would not affect the atmosphere.

The aphodid burner not only promises a significant breakthrough in steam cycle efficiencies, but also provides a means of generating power without objectionable air pollution. This burner is still in the experimental stage but there appears to be no serious obstacle to either its development or the development of its associated turbine equipment.

5.2.2 HYDROGEN FUELED INTERNAL COMBUSTION ENGINE

Today's internal-combustion (I-C) engine traditionally burns fuel with air to produce shaft power. This fuel is usually liquid or gaseous hydrocarbons derived from petroleum, and may be brought to the engine in pipelines (stationary engines) or carried with the engine (mobile power plant). The engine generally falls into one of the following categories: carbureted reciprocating, injected reciprocating, rotary trochoid (Wankel), rotary turbine (gas turbine or jet engine), and rocket.

In all but the last of the above engines the fuel acts on the engines working fluid (air) to increase its energy content so that the engine can extract a portion of this energy as useful work. In theory, the performance of an engine is unaffected by the type of fuel. In reality, however, the performance and emissions of an engine are directly related to the type of fuel burned.

Engine combustion is extremely complex and any analysis should consider both the engine and the fuel as a system, forming a basis for comparison such that the same engine operating on two different fuels form two separate systems.

In theory, I-C engines will utilize a hydrocarbon fuel (iso-octane, C_8H_{18}) in an air oxidizer as described by the following simplified equation

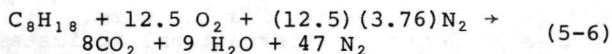

In reality, however, the reaction seldom if ever progresses to this ideal end state. In addition, most fossil fuels contain impurities such as sulfur and metal compounds. More realistic reaction products, therefore will include carbon dioxide, water, nitrogen, carbon monoxide, nitrogen oxides, hydrocarbons, sulfur compounds, metallic compounds, alcohols, aldehydes, and ketones; all but the first three of

which are undesirable air pollutants.

In contrast to the reaction described in equation 5-6, an engine fueled with a hydrogen-air mixture would theoretically yield the following products

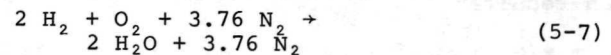

In an actual engine with excess air entering the reaction, one would expect the following reaction

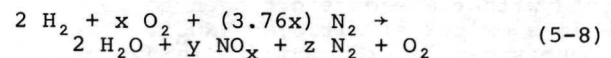

The only expected atmospheric pollution from a hydrogen fueled engine would be nitrogen oxide compounds.

The combustion and emission characteristics of hydrogen appear so favorable that research into hydrogen engine technology has expanded at a rapid rate, especially in the last five years. Results have been so favorable that all of the previously defined engine types have been operated on hydrogen with relative success.

Extensive tests relating emissions and performance have been performed by R. G. Murray and R. J. Schoepel at Oklahoma State University (OSU) using an injected reciprocating single cylinder engine (See Figure 5-5).

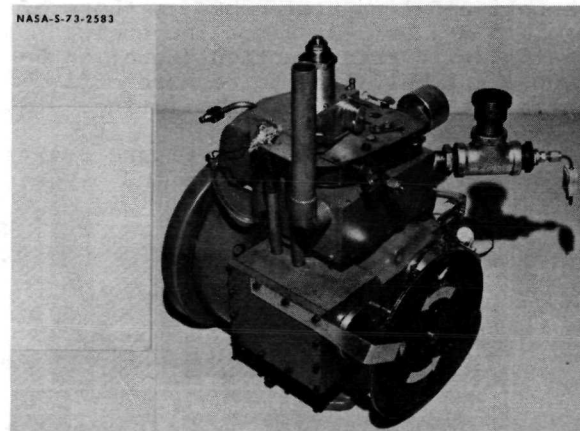

FIGURE 5-5
OKLAHOMA STATE UNIVERSITY
HYDROGEN FUELED ENGINE

Wide-open-throttle nitric oxide emission characteristics of this engine and similar

fossil fueled engines are shown in Figure 5-6.

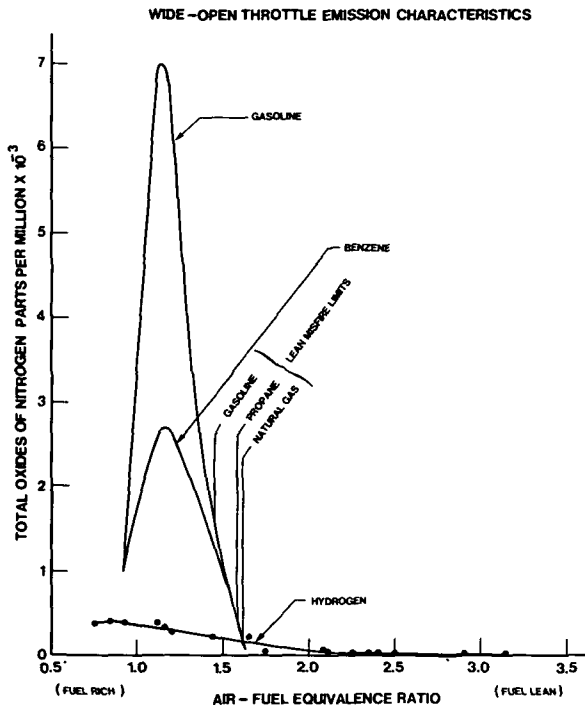

FIGURE 5-6
EMISSION CHARACTERISTICS OF
OKLAHOMA STATE UNIVERSITY HYDROGEN ENGINE

The top curve of this figure represents an expected maximum emission from a carbureted gasoline fueled engine, while the middle curve represents a reasonable minimum for a carbureted fossil fueled spark ignition (S-I) engine. The lower curve represents measured NO_x emissions from the OSU engine, which is less than one-fifth of the expected emissions shown by the other two curves.

The injection of hydrogen at or near proper combustion time eliminated any tendency for knock or crankcase explosion, provided smooth engine operation throughout a wide range of air-fuel ratios and engine speeds, and eliminated hydrogen displacement of air in the induction system which yielded an improved volumetric efficiency.

This engine was designed specifically to test emission and performance characteristics. No attempt was made to improve emissions or adapt the engine to a practical use. Operational characteristics, however, indicated that further development could have improved performance and adapted the engine to a practical use.

The work of Murray and Schoeppl was directed primarily towards correlating engine emissions to performance. Previous to their effort, extensive engine testing

had been performed in Germany by Rudolph Erren and was later continued in England by Erren & Campbell (5-20). Erren's work led to successful vehicle operation in Germany before World War II. These vehicles used either hydrogen or hydrogen-hydrocarbon mixtures for fuel. Unfortunately, most of the documentation of this work was destroyed in World War II (5-20).

R. O. King & co-workers experimented with hydrogen fueled engines but were unable to operate engines for extended (more than 12 hours) periods of time without experiencing severe knock. The knock encountered by King was caused by carbon or ash deposits from burned lubricating oil. This tendency towards knock may limit the usefulness of the carbureted hydrogen engine in some utilization areas.

Recently several automobiles have operated for limited periods of time on hydrogen, notable among these are

- M. R. Swain and R. R. Adt of the University of Miami, who have modified a 1600 cc Toyota engine with a 9 to 1 compression ratio. This engine uses a modified injection technique.
- a UCLA student-faculty group has operated several single and multi-cylinder carbureted engines on hydrogen as well as an 8 Cylinder Ford engine equipped Gremlin automobile.
- an Illinois Institute of Technology student-faculty group ran a 1972 Vega with a propane carburetor (5-21).
- Roger Billings and others at Brigham Young University entered a carbureted Volkswagon in the 1972 urban vehicle competition and won the emissions category in a field of over 60 competing vehicles.

Figure 5-7 shows nitric oxide emission re-

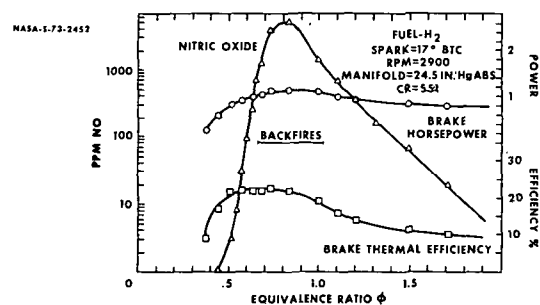

FIGURE 5-7
EMISSION CHARACTERISTICS-
CARBURETED H₂ ENGINE

ported by Billings for a carbureted engine with a 5.5 to 1 compression ratio operating with various air-fuel ratios. Figure 5-8 illustrates the effect of water induc-

NASA-5-73-2462

NASA-5-73-2451

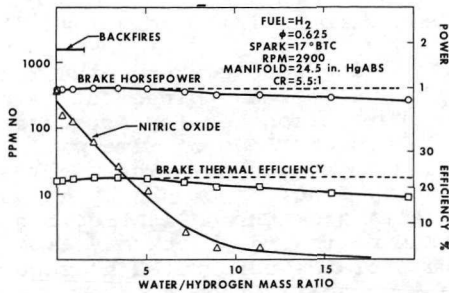

FIGURE 5-8
WATER INJECTED EMISSION CHARACTERISTICS

tion on engine emission. The peak emissions reported by Billings are about ten times higher than those reported by Murray & Schoepel. The carbureted technique used by Billings may account for this marked increase in pollution level. The injection principle undoubtedly leads to charge stratification with a resulting reduction in NO_x emission.

All of the above investigators except Erren have limited their investigation to spark ignition (S-I) reciprocating engines. Erren worked with both S-I and compression ignition (C-I) engines successfully.

Investigators at the Brookhaven National Laboratory have operated a Wankel (rotary trochoid) engine on mixtures of hydrogen and air. Successful operation was achieved; however, no emissions data are available.

The first reported gas turbine to operate on hydrogen was a converted J-57 Pratt & Whitney engine (see Figure 5-9a and b).

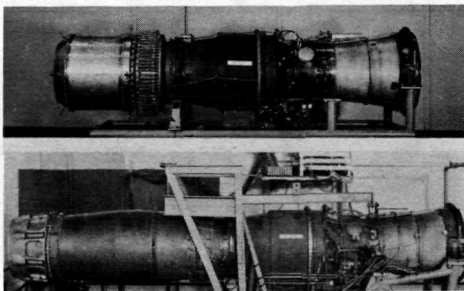

FIGURE 5-9A
COMPARISON OF HYDROGEN AND JP-FUELED J57
PRATT & WHITNEY ENGINES

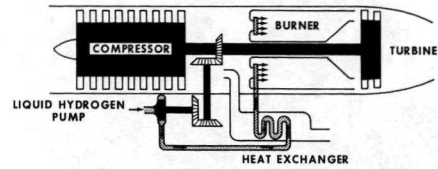

FIGURE 5-9B
SCHEMATIC DIAGRAM OF THE
MODIFIED J57 ENGINE

Gaseous hydrogen was supplied to J-57 axial tube single-can burners by an auxiliary centrifugal pump and gasifier system. The stable operation of the J-57 confirmed that conventional gas turbines could be readily adapted to hydrogen fuel (5-22).

A second turbine, the Pratt & Whitney 304, (see Figure 5-10a and b), was

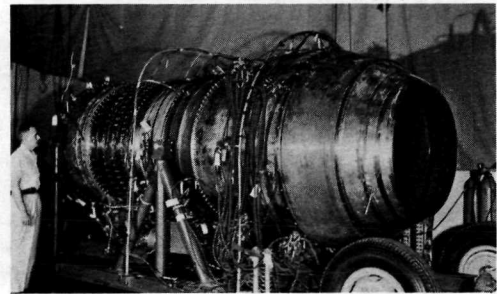
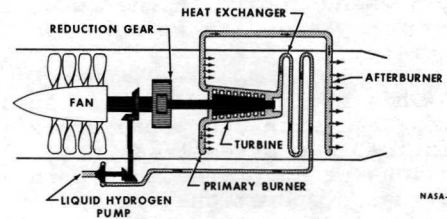

FIGURE 5-10A
PRATT & WHITNEY MODEL 304 HYDROGEN
FUELED GAS TURBINE ENGINE



NASA-5-73-2465

FIGURE 5-10B
SCHEMATIC DIAGRAM OF THE
PRATT & WHITNEY 304 ENGINE

ORIGINAL PAGE IS OF POOR QUALITY

specifically designed to utilize the expansion of liquid hydrogen to provide the work for the compressor. The combustion energy was utilized to provide thrust. All performance predictions for this engine were confirmed within the first 25 test hours when the project was terminated in 1958.

The last reported hydrogen gas turbine operation occurred when the National Advisory Committee for Aeronautics (NACA) converted one engine of a B-57 bomber to hydrogen. Testing started with the airplane at cruise whereupon the left engine was switched to liquid hydrogen from the left tiptank. No performance or emission data are reported for any of these engines; however, all were reported to have operated excellently.

Hydrogen-oxygen fueled rocket engines have been a spectacular success in recent years. The Saturn series of rockets has utilized $H_2 - O_2$ engines in upper stages for numerous successful earth and moon orbits. Figure 5-11a and b is an early engine and its schematic, the P & W Model RL10 (5-22). Liquid hydrogen is

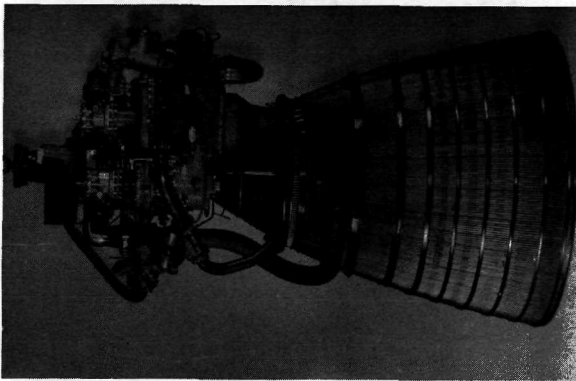

FIGURE 5-11A
THE PRATT & WHITNEY RL10 ROCKET ENGINE

NASA-573-2463

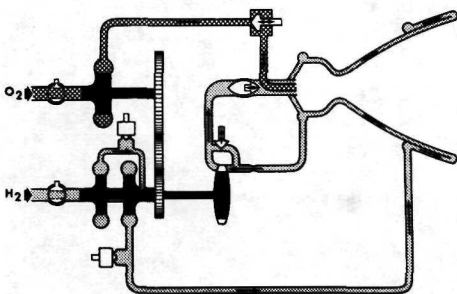

FIGURE 5-11B
ENGINE CYCLE OF RL10 ROCKET ENGINE

pumped to 1000 psi and directed to the thrust chamber cooling jacket where its temperature is increased sharply. It then expands through a turbine which provides the pressurization work for both the hydrogen and the oxygen. These engines have undergone over 100 firings for a total time of six hours without repair.

Hydrogen fueled engine research and development is far from complete; however, the preliminary efforts performed to date indicate that all existing engine types can be operated with hydrogen. All of these engines appear to be capable of excellent performance characteristics at very low levels of pollution.

5.2.3 CATALYTIC BURNERS

A novel property of hydrogen that gives it a marked advantage over other fuels is its ability to react with the oxygen in air when in contact with a catalyst.

This property has allowed the fabrication of unusual flameless heating devices. Research by the Institute of Gas Technology and the American Gas Association has produced several types of hydrogen fueled catalytic burners that have been successfully demonstrated to the public (5-21).

Detailed information is not available on these burners; however, it is known that a very thin catalytic film, probably platinum or palladium, is suspended on a substrate (ceramic). When hydrogen is passed over this surface, flameless combustion takes place. The rate of combustion and the resulting temperature are functions of the rate of fuel supply and the exposed surface area of the catalyst.

An important advantage of this burner is that its operating temperature is under $1750^{\circ}K$, which is below the temperature of formation of significant quantities of nitrogen oxides.

Another advantage of a catalytic burner is its inherent safety. An inoperative ignition source or a burner accidentally left on poses a serious problem in a natural gas appliance. A hydrogen catalytic heater, on the other hand, would only produce unwanted heat if accidentally left on.

Developmental efforts on catalytic burners are far from complete; however, it appears that such a device could be used for water heating, cooking, process heating and space heating. The only likely technical obstacles to development of practical systems are cost and availability of catalytic materials. These

materials must be not only inexpensive, but impervious to poisoning by fuel additives and impurities.

5.2.4 FLAME BURNERS

Hydrogen in the gaseous form can be used as fuel for all combustion applications that use natural gas today. Hydrogen combustion characteristics and the effect they have on existing natural gas burners are discussed in this section. The changes that will need to be made in burner design, valves, and metering devices are also studied.

There are essentially two types of combustors used today for heating and cooking--the catalytic combustor described in Section 5.2.3 and the gas phase or open flame combustor that is examined in this section. The most common type of burner today, the flame burner, works on the principle that a jet of fuel entrains air and the flammable mixture is burned downstream in one port or a series of ports (5-23). The satisfactory performance of a burner depends upon flame stability, which is bounded by the flash-back and blow-off tendency. When fuel velocity is higher than flame velocity, blow-off occurs (the flame advances away from the burner) and the flame is extinguished. If fuel flow velocity is slower than flame velocity, flame enters the burner or flash-back occurs. Both of these are affected by the fuel/air ratio and gas temperature (5-26). The stable flame region for methane fuel is shown in Figure 5-12.

The characteristics important to flame burners will be reviewed as follows:

- Hydrogen burns in air with a non-luminous almost invisible flame (5-25)
- The temperature of hydrogen air flames is hotter than methane air flames at stoichiometric conditions (2400°K compared to 2190°K)
- Flame velocity for hydrogen is very high--about 10 times the flame velocity of methane (5-25)
- Limits of flammability for hydrogen and methane are similar at the lower limit but vary greatly at the upper limit. The limits of flammability of hydrogen in air at ambient conditions is 4-75 volume percent, methane in air is 5-15 volume percent.
- The quenching distance, the maximum size opening through which a flame will not pass is approximately 0.06 cm for hydrogen as compared to 0.23 cm for methane (5-24, 5-26).
- Ignition qualities of hydrogen (5-24) require much less energy than that required for methane (Figure 5-13)

NASA-5-73-2459

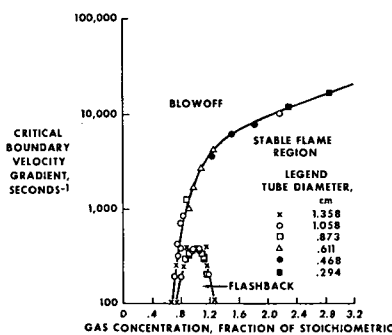

FIGURE 5-12
FLAME-STABILITY DIAGRAM FOR A
FUEL CONTAINING 100% CH₄

The combustion characteristics of hydrogen are quite different than those of methane.

NASA-5-73-2449

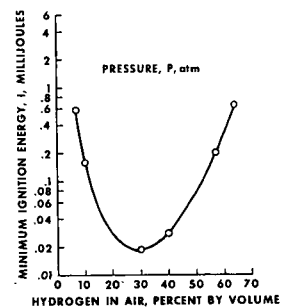

FIGURE 5-13
SPARK IGNITION ENERGIES FOR
HYDROGEN-AIR MIXTURES AT VARIOUS PRESSURES

All of these characteristics must be con-

sidered when designing or using flame type burners.

Hydrogen burners will be different than natural gas burners in the following ways. To produce the same amount of heat, about three times the volume of hydrogen, as compared to methane, is required. But since the flow rate of hydrogen through a given area is approximately three times as high as methane at the same pressure, existing fuel jets should be sufficient. Since hydrogen is more prone to flashback but has a much larger flame stability range (Figure 5-14), burner port size can

NASA-5-73-2448

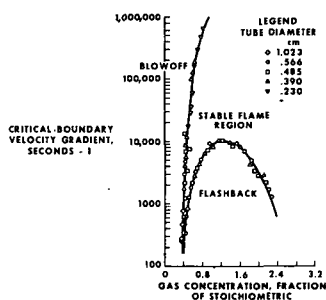

FIGURE 5-14
FLAME-STABILITY DIAGRAM FOR A FUEL
CONTAINING 99.7% H₂ AND 0.3% O₂

be made much smaller, thus increasing the quenching effect (5-26). Quenching effects (5-24) of different hydrogen-air mixtures are shown in Figure 5-15.

Pilot lights or some electrical ignition devices should work well because of hydrogen's low ignition energy. Hydrogen burns at about 200°K above methane flame temperature. This increase could cause existing burners to become too hot; therefore, the selection of suitable burner materials is very important.

Converting to a hydrogen fuel will necessitate the modification or replacement of all natural gas burners for the following reasons: port size will have to be reduced (flash-back control), air mixture devices changed because of different fuel volumes, and the burner head itself may need replacement in order to avoid material problems due to high temperatures.

NASA-5-73-2447

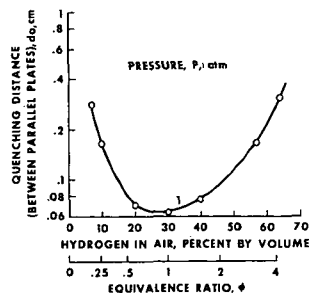
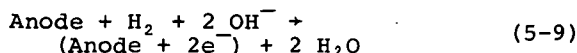

FIGURE 5-15
EFFECT OF HYDROGEN CONCENTRATION ON
QUENCHING DISTANCE OF HYDROGEN-AIR MIXTURES

5.2.5 FUEL CELLS

In principle, fuel cells are much like batteries; they are devices to transform chemical energy directly to electrical energy without using an engine as an intermediate step. Fuel cells differ from a battery in that the chemical energy input to the cell can be continuously replenished while a battery has a limited supply and once this supply is exhausted the battery is useless.

The simplest fuel cell is a hydrogen oxygen fuel cell as shown in Figure 5-16. Hydrogen flows to the anode where it breaks up into hydrogen ions and electrons according to equation



Oxygen, at the same time, flows to the cathode and reacts as illustrated by the equation

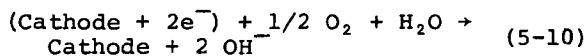

The net result of these two reactions on opposite sides of the cell is



NASA-S-73-2492

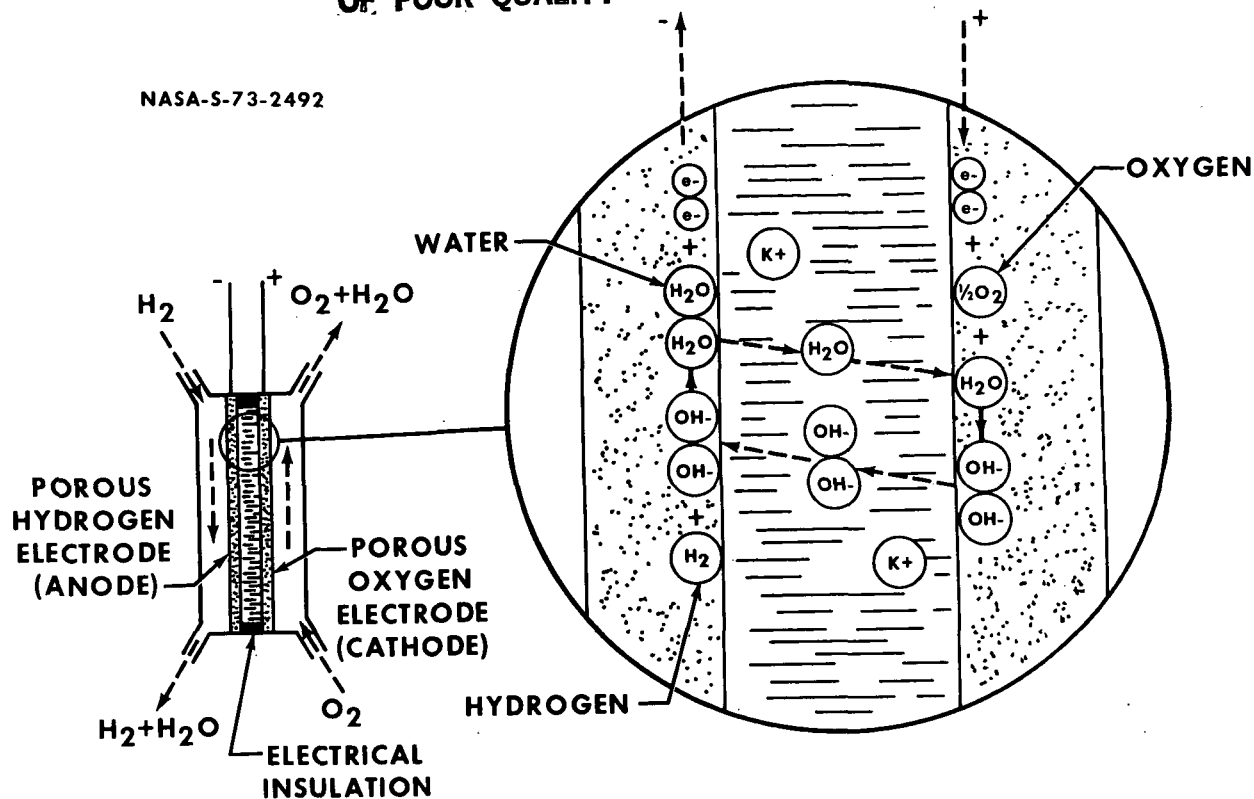

FIGURE 5-16
CROSS SECTION OF SIMPLE HYDROGEN-OXYGEN FUEL CELL

where the hydroxyl ion is transported from the cathode to the anode through an electrolyte and the electrons are transported from the anode to the cathode via an external circuit. This electron flow is the useful electrical output of the fuel cell. If the external circuit is opened, the cell stops functioning automatically.

Electrolytes can be acids, bases, or molten salts. For hydrogen, however; potassium hydroxide (KOH) is usually preferred to acids since it is less corrosive and since under comparable conditions, the oxygen electrode gives about 0.1 volt more potential.

Air can also be used as the oxidant, however, it must continuously be circulated so the excess nitrogen and other gases can be removed. If this is not done, the nitrogen will significantly interfere with oxygen-electrode contact, seriously limiting output. In addition, contaminants in the air can poison catalysts contained by the electrode, reducing the life of the cell.

Catalysts are needed at the reaction interface to assist the breakdown of hydrogen and oxygen into ions. Precious metals, such as platinum, palladium, or rhodium are the best catalysts; however, nickel can be used with hydrogen in KOH electrolytes (5-27). The most promising electrode technology uses plastic-bonded electrodes. Here small particles of Teflon are mixed with small particles of platinum black. The resulting paste is pressed, heated and sintered into an electrode that is thin, flexible, and strong, yet one that remains porous and resists flooding due to the hydrophobic properties of Teflon. The electrical output of each cell is direct current electricity at a peak theoretical potential of 1.23 volts. Voltage, however, drops with increased current until the usable voltage of each cell may be approximately 0.8 volts. Cells must be stacked in series to get higher voltage.

Actual current outputs of H_2 - O_2 cells usually ranges from 40 to 155 amperes per square foot of projected electrode surface. Power outputs of typical H_2 - O_2 fuel cells range from 50 to 2500 watts. Cell life of

up to 3000 hours has been reported.

The most spectacular success for fuel cell application has been its use in Gemini and Apollo space vehicles. When weight, required useful life and power output are all considered, the fuel cell was judged to be the best power source for these spacecraft.

Main advantages for the fuel cell are high efficiency, absence of moving parts, and lack of noise. Unlike heat engines, the fuel cell is not limited by the Carnot cycle theory. Thermal efficiencies of about 83 percent (coulombic efficiency of nearly 100 percent) can be achieved at low currents. Practical cells can run at thermal efficiencies of 60 percent with present technology. This efficiency can be quite attractive when compared to present steam power plant efficiencies of 55 percent maximum.

Disadvantages are high cost, and scarcity of electrode materials. The direct current electrical output may be a disadvantage depending on application. If alternating current is required, an inverter must be used which adds to the cost and weight and reduces overall efficiency.

Fuel cells function excellently in some applications particularly in space craft. Advances in catalyst and electrode technology, as well as cost, will have to be made, however, before fuel cells can be considered seriously for general use in the residential, commercial, transportation or industrial market.

5.2.6 OTHER DEVICES

Magnetohydrodynamic (MHD) electric generation plants have received some attention in recent years as possible high efficiency generation systems. Problems with materials, and low magnetic field density however eliminate this scheme as a practical power generation device in the near future.

The Stirling cycle engine has been in limited use for years, particularly in Europe (5-28, 5-29). This includes use both as an engine and a refrigerator. Since the Stirling engine can use heat transfer between substances, as well as combustion, to produce power, it has the capability of deriving power from the vaporization of cryogenic hydrogen. Characteristically this cycle has a higher thermal efficiency, but, further development will be needed to overcome weight and endurance problems.

5.3 HYDROGEN UTILIZATION DEVICES

5.3.1 RESIDENTIAL AND COMMERCIAL USE

5.3.1.1 ENERGY USE PATTERNS

The residential uses of energy are those associated with the dwelling units of man. The form of dwelling unit varies widely, but generally the individual unit (house or mobile home) is preferred by the 25 to 60 age group. There is a trend toward multiple units or apartment living for the 20 to 25 and over 60 age groups (5-5). In 1970, there were 64.8 million households in the U. S. This is expected to increase to 90 million (39 percent increase) by the year 2000.

The commercial area encompasses energy requirements of the facilities utilized by business, but not for the production of producer or consumer goods. Typical facilities are retail, wholesale and sales organizations, hotels, and office space occupied by service and industrial groups.

Eighty-eight percent of the total residential and 77 percent of total commercial energy is expended on: space conditioning (heating and air conditioning), water heating, cooking and refrigeration (5-16). Residential energy needs, the larger of the two, are supplied by electricity (15 percent) and fossil fuels (85 percent). A summary of the 1970 household appliance ownership and energy usage is presented in Table 5-4. Commercial, representing approximately 15 percent of total residential and commercial energy demand, derives 65 percent of its energy from fossil fuels and 35 percent from electricity.

The historical growth in both the residential and commercial areas can be attributed to demands for an increased quality of living. Fulfilling these demands has required increased energy consumption in the household and increases to make services available. The last decade has seen particularly large increases in air conditioning and other comfort items in household and commercial buildings. Historical consumption annual growth rates have been 2.7 percent for residential and 3.7 percent for commercial (5-5).

As facilities necessary to provide comfortable surrounding are completely installed in the home, some limit is reached. This limit, interpreted as a saturation demand for the individual household, was obtained for a residen-

TABLE 5-4
 PATTERNS OF 1970 HOUSEHOLD APPLIANCE
 OWNERSHIP AND ENERGY USAGE

Household Item	Number of Households with Item (millions of Households)			Percent of Households	Energy Use million Btu per Household Year)
	Fossil Fuels	Electric	Total		
Space Heating	61.0	3.8	64.8	100.0	110.0
Air Conditioning (Room)	--	26.0	26.0	40.6	7.0
Air Conditioning (Central)	0.5	8.4	8.9	13.7	
Water Heating	31.9	3.8	35.7	80.5	28.5
Cooking	29.3	35.5	64.8	100.0	10.5
Clothes Dryer	6.1	28.6	34.7	53.5	3.4
Refrigeration	--	63.9	63.9	100.0	11.4
Other					20.4
Total					191.2

tial dwelling by assuming complete space conditioning and proliferation of appliances. Commercial uses are expected to grow at 3.5 percent. Figure 5-17 pre-

sents the saturation demand for the residential and commercial area.

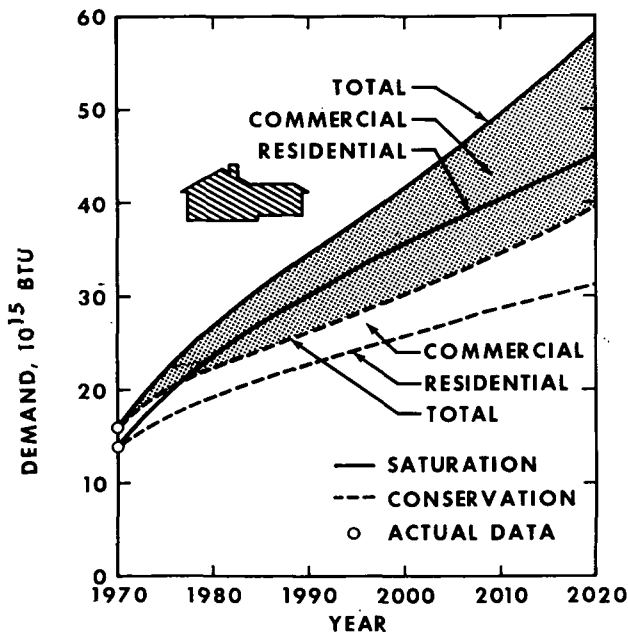

FIGURE 5-17
 SATURATION AND CONSERVATION DEMAND FOR
 RESIDENTIAL AND COMMERCIAL, 1970-2020

Effects of the conservation of energy will most probably be seen in this area due to the looming shortage of fossil fuels necessary for electrical power generation and direct consumer use. Shortages and pricing changes can be expected to provide the incentive necessary for more energy conscious design in appliance and new building design.

The conservation curve of Figure 5-17 reflects decreased demand in several areas. A major conservation area in both residential and commercial is the use of better insulation and design techniques which can reduce the thermal losses of a structure by 50 percent (5-16). This will eventually produce a 25 percent savings of energy in residential and 30 percent in commercial. Unfortunately, full effect of this is long term since its application is only to new construction.

Besides the above, the following savings are anticipated by 1985 due to increased device efficiency (5-3):

Area	Percent Savings
Water Heating	10
Ranges	10
Refrigeration	20
Air Conditioners	20
Lighting	25

These savings represent approximately 6 percent of the anticipated 1985 household load of 400 million Btu per household per year.

5.3.1.2 FEASIBILITY OF USING HYDROGEN

The residential and commercial demand for fuel energy can be satisfied by hydrogen fuel. The development of some consuming devices has not yet proceeded to the practical state; however, sufficient work has been done to insure feasibility of hydrogen use in this market (5-21). Excluding electricity, residential and commercial energy use is largely comprised of space and process heating which can be satisfied by one of the following types of hydrogen fueled devices:

- Converted fossil fuel vented combustors
- Unvented H₂/air combustors
- Catalytic Burner
- Fuel Cell

Some implications of the use of these devices follows.

Present fossil fuel burning devices such as furnaces, ranges and water heaters can be converted to hydrogen by changing burners, controls, and pilot lights. The practicality of such a changeover, however, is questionable considering conversion cost and remaining appliance life. A direct replacement of each device by a unit specifically designed for hydrogen combustion would be more practical.

Changeover of residences and offices will also require an upgrading of the supply system. Since hydrogen tends to leak in systems that are leak proof for natural gas, the entire supply system must be inspected, repaired, or replaced. Additionally, conversion will require replacement of meters and pressure regulators. In view of this entire system replacement appears to be necessary.

In contrast to the above vented combustor, hydrogen also allows the utilization of unvented heaters where hydrogen and air are burned, forming water vapor, traces of oxides of nitrogen, and excess air. These devices appear highly attractive and feasible, although humidity control may require room venting with subsequent make-up air.

The catalytic burner is probably the most promising long-range device for space or process heating (5-21). In this device hydrogen air mixture reacts upon contact with a catalytic surface. The temperature and quantity of heat released can be controlled by adjusting the quantity

of hydrogen fuel admitted to the catalytic surface. Safety and the elimination of oxides of nitrogen are the chief advantages of the catalytic burner, while expense and catalytic material availability may be serious drawbacks.

Another catalytic device, the fuel cell (5-27), shows promise as an energy package. Ideally, this unit could provide both electricity and space heating at a significant increase in efficiency over conventional methods. Present electrode and catalyst technology, however, prevents serious consideration of such a fuel cell package in the short to medium term.

The use of absorption (Servel) type refrigeration and air conditioning units should be stressed. These units are somewhat bulkier than electric machines; however, their overall efficiency is greater and they are adaptable to hydrogen.

In general, the conversion of the residential and commercial sector can be implemented best by total conversion of existing structures to vented or unvented combustors. Assuming development and availability has progressed sufficiently, catalytic burners appear to be feasible for all new construction. Adoption of fuel cell systems should be strongly considered for future construction once practical systems have been developed.

5.3.1.3 IMPACT EVALUATION

The most unfavorable impact of using hydrogen in the residential and commercial market will probably be the cost of changeover. Other factors such as safety and pollution will be less of a problem. None of these factors should be so significant that the implementation of hydrogen usage will be impaired.

As previously mentioned, owners of existing structures which change from another energy source to hydrogen fuel may have to purchase all new appliances and heaters. The cost of these devices should be comparable to the cost of similar natural gas devices.

A significant additional expense will be system upgrading, since new piping, pressure regulators and meters will be needed for each unit. This expense will be a serious deterrent to large-scale conversion of small residences and commercial buildings.

In contrast, the cost of new construction specifically designed to accommodate hydrogen should be comparable to natural gas units. Unvented combustors and catalytic heaters are particularly attractive in new construction since the efficiency

of these units is higher. If the catalytic heater is perfected at a reasonable cost, it will be the ideal unit since it has no NO_x emission.

The overall safety of using hydrogen in a business or residence is probably no worse than with natural gas; there are, however, two factors that will need careful consideration.

First, hydrogen burns with a nearly invisible flame. It is therefore difficult to determine whether a burner is actually on. Some authorities (5-21) propose the addition of illuminants; however, no specific substance has been proposed. The discovery of an illuminant that does not pollute the air or poison catalytic burners may be a difficult task.

Second, system leakage is difficult to detect since hydrogen is a colorless, odorless gas. Odorants such as those used in natural gas have been suggested but the difficulties of development of specific substances is similar to that of the illuminants.

Fortunately, leak detectors (5-25) are both available and are effective in detecting the presence of hydrogen in air before flammable concentrations build up. Since hydrogen is a buoyant gas, concentration from leaks first tend to build at the ceiling and other high spots in a room. Location of leak detectors at these locations should give adequate warning for all small and medium leaks. Automatic shutoff hydrogen supply valves triggered by a leak detector would be a desirable feature. Further development will be needed to provide low cost detectors for residential use.

Design of appliances to discourage tinkering by untrained repairmen would also help prevent accidents. Such devices should incorporate special threads, screws, wrench flats, etc., so that only trained repairmen who have both the knowledge and tools can perform repair operations.

Water from combustors and catalytic devices may be condensed to a liquid and collected as needed to control humidity. This is a significant improvement over fossil fuel vented systems which exhaust at a temperature above the boiling point of water.

Oxides of nitrogen from hydrogen combustion appear to be significantly less than from fossil fuel combustion (5-30). Nitrogen compounds appear to be totally absent from catalytic devices (5-27).

It appears that the adaptation of the residential and commercial market to hydrogen fuel is highly feasible technically, acceptable economically, and desirable

ecologically.

5.3.2 INDUSTRIAL-FUEL USAGE

5.3.2.1 ENERGY USE PATTERNS

The consumption of energy in the processing of materials is currently the largest single area of energy use (30 percent); including the use of electrical power and fossil fuels. Energy is consumed for a variety of purposes; electricity for heating, mechanical drive and electrolytic processing, and a variety of other uses; fossil fuels for direct heating and steam generation. Some of the principal sectors of industrial-fuel are listed below with the percentage in parentheses representing its 1968 share of area energy use (5-31).

- Primary metal industries (21 percent)
- Chemicals and allied products (20 percent)
- Petroleum refining and related industries (11 percent)
- Food and kindred product industries (5 percent)
- Stone, clay and glass products (5 percent)
- Paper and allied products (5 percent)

The energy demands of the industrial-fuel area are supplied by a variety of fuel sources; natural gas, coal, liquid hydrocarbons and electricity. The 1970 amount and percentage contribution of each of these energy sources is detailed in Figure 5-18. Note that natural gas supplies

NASA-572-2479

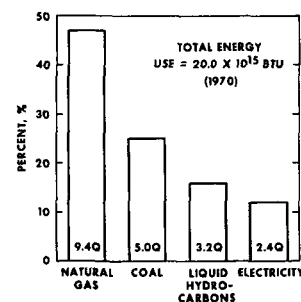

FIGURE 5-18
COMPARISON OF SOURCE FUELS FOR
INDUSTRIAL-FUEL, 1970

almost one-half (47 percent) of the area's energy needs. Historically all sectors

have shown a decrease in the energy used per unit output. This trend has been altered recently due to environmental restrictions and the greater effort needed to obtain raw materials as supplies become increasingly scarce and more remote. The past increases in efficiency (due to new processes, automation and recycling) were largely responsible for decreases in energy per unit output (5-15); however, future increases in efficiency are expected to overtake the short, present term trend of increased energy per unit output.

Growth in industrial-fuel has been 3 percent per year in the past and is expected to continue at this rate for future demand. This continuation is anticipated due to the need for new products, population growth and necessary replacement of presently owned goods. The projected demand is shown in Figure 5-19. Note that there is no

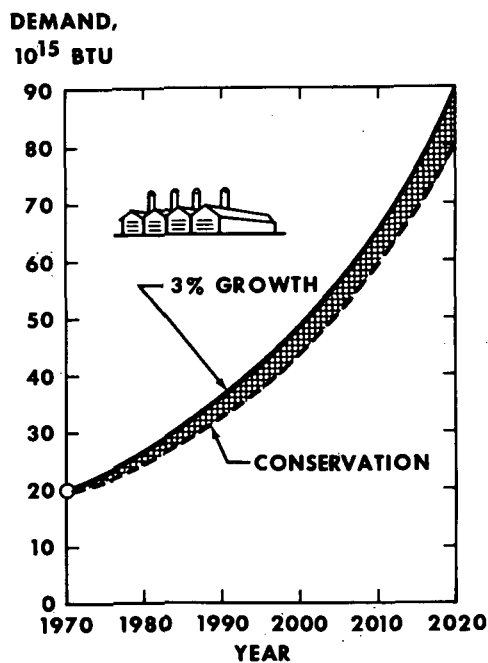

FIGURE 5-19
ENERGY AND CONSERVATION DEMAND FOR
INDUSTRIAL-FUEL, 1970-2020

saturation in this curve, since a 3 percent per year growth rate is expected in the future energy use.

Future conservation is anticipated in this area as energy economics are changed.

The most likely areas are:

- More efficient equipment and processes
- Better maintenance policies
- Replacement of old equipment
- More conscious use of energy

As the conservation measures are introduced, they will produce an energy savings up to 10 percent. Figure 5-19 presents the demands under this 10 percent savings condition. Conservation projects to a 50 percent increase in energy use in 1985, while a 3 percent per year saturation type growth represents a 56 percent increase.

5.3.2.2 FEASIBILITY OF USING HYDROGEN

All industrial applications that use natural gas as a fuel for heating and power generation (electrical and/or shaft horsepower) can be converted to the usage of hydrogen. Some of these usage areas will require extensive modification, but others will be quite simple. The primary reason for converting industry to hydrogen is the saving of fossil fuels (30 percent of the total fossil fuels consumed in the U. S. in 1970). Natural gas devices used for heating purposes, either space or industrial process heating, can be converted to hydrogen use quite easily. The conversion would consist of burner and metering modifications. This will be necessary because it takes about three times the volume of hydrogen to the volume of natural gas to obtain the same heating value, even though hydrogen only needs about 75 percent as much air for combustion (5-21).

Spark ignition (S-I) and compression ignition (C-I) engines that are used to develop shaft horsepower can be adapted to burn hydrogen by using present technology. This is especially attractive since the engines are stationary and the fuel can be delivered directly to them from existing outlets the same as natural gas fueled power plants. One of the attractive conversions is the natural gas or liquid hydrocarbon fueled gas turbine power plant. Hydrogen can be used to fuel gas turbines and there appears to be no significant problem involved. Hydrogen can also be used for blade cooling, allowing higher inlet temperatures with a resulting increase in turbine efficiency. Industrial process heating (steam) from hydrogen fired boilers can be used to generate electricity for various manufacturing processes. After the primary work is accomplished, the residual exhaust heat can be used for space heating, as currently done with natural gas fired systems. The feasibility of changing from fossil fuels to hydrogen is possible, and necessary, if we

are to conserve fossil fuels. The research and development in fuel cells at the present time has not led to a device that is commercially feasible, but a major breakthrough in this area could be very attractive for industry.

5.3.2.3 IMPACT EVALUATION

The impact of a change in industry from fossil fuels to hydrogen will be concentrated in two major areas, cost and environment. The cost will result from changing existing fossil fuel consuming devices, such as burners, to hydrogen use and the implementation of safety measures that are needed for a hydrogen system. The fossil fuel combustors that are in use today must be modified to use hydrogen or replaced if such modification is not possible. As discussed previously, preliminary investigations indicate that the stationary internal combustion engine can be converted to hydrogen fuel without major expense. Another cost that cannot be overlooked is the implementation of safety features in the hydrogen system. This would embrace a change of all burners, meters, valves and any other devices that are used for hydrogen. All devices should be designed so that special tools are required to adjust or repair. This would discourage unauthorized personnel that do not have the necessary tools or training from 'working' on the equipment and possibly causing an accident.

The environmental impact will be primarily a reduction of air pollution, which can help offset installation and operating costs. The level of noise created by industrial or manufacturing processes will not be affected by the changeover to hydrogen, unless plants are replaced by fuel cells, which does not appear likely at the present.

5.3.3 TRANSPORTATION USAGE

5.3.3.1 ENERGY USE PATTERNS

The transportation area encompasses the energy in all fuels consumed to provide motive power for passenger and freight movement. This area, the most visible of all energy users, consumes 24 percent of total energy. A variety of modes, all fossil fuel based, are prevalent. Some of these modes are:

- Passenger car travel
- Truck freight systems
- Rail and water freight systems
- Mass transit systems
- Aircraft travel
- Bus and rail travel
- Off road uses, construction and agriculture
- Recreational travel

The 1970 consumption for major transportation segments is detailed in Figure 5-20.

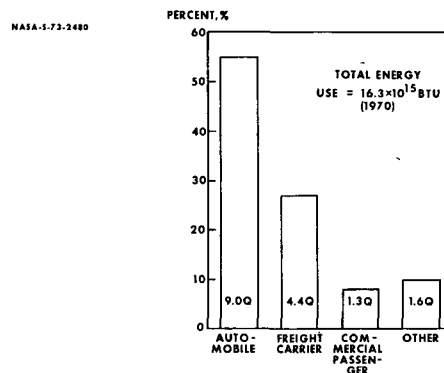

FIGURE 5-20
COMPARISON OF FUEL USAGE FOR
TRANSPORTATION, 1970

The 4.1 percent yearly growth rate (5-31) of the recent past has occurred primarily due to increases in truck, automobile and aircraft traffic. This, of course, is readily seen from the proliferation of highway and airport construction, which encourages a decentralized style of living, working and recreation.

The demand for transportation energy will continue to grow, but a decline in the growth rate is anticipated. Saturation demand is defined by a limit in private automobile travel. Presently automotive travel represents a considerable amount of time in each person's day (approximately one hour). However, there is some reasonable limit on the time available for travel when other personal activities are taken into account.

The movement of freight and commercial passenger travel are expected to grow at the established rate of 3 percent per year. Projected demand for transportation with the above saturations is pictured in Figure 5-21.

The automobile and truck are an integrated unit of our transportation and lifestyle system. Radical shifts from this system are difficult due to the physical facilities now in place. An example of this is the housing arrangement which

NASA-5-73-2493

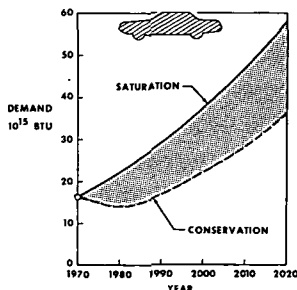

FIGURE 5-21
SATURATION AND CONSERVATION DEMAND FOR
TRANSPORTATION, 1970-2020

places the employed in a widely scattered array, thus requiring a transportation system capable of moving a large number of people to a diversity of locations.

Conservation efforts to reduce total miles traveled can reasonably be expected to occur in the transportation area as the forecasted energy shortage and rising fuel costs become more dominant factors. A total of 35 percent of the private automobile travel is work oriented (5-16). An immediately available conservation effort is the use of car pools for this travel. Even the use of extensive car pooling can effect only about 20 percent of the transportation energy use and could result in a 10 percent savings. A more realistic view of work oriented traffic would expect 20 percent of the travel by one person in a car, 40 percent in multiple occupancy

autos and 40 percent by some form of mass transit. This would cause an 11 percent fuel savings by 1990. Another change in the private automobile which can be anticipated by 1985 is extensive use of the more economically sized vehicle. These effects on fuel consumption would amount to a 33 percent savings for auto use. Nearly two-thirds of car usage is independent of employment travel. As economic pressure is exerted, some changes are anticipated in this area. Table 5-5 shows some of the expected changes in the patterns of use for various purposes.

Commercial freight traffic consumes a sizable portion (27 percent) of the energy used in transportation. As fuel costs rise and highway traffic increases, some shift in the mode of freight shipment is anticipated. The shifts to modes requiring less energy is expected to reduce the truck's portion of energy use by 50 percent. The cumulative effect of these conservation efforts on transportation energy use is shown in Figure 5-21.

A less obvious method for conservation in the commercial freight area is minimizing the multiple shipment of goods during the manufacturing process. Shortages and increased cost of fuel will exert strong economic pressures to reduce this redundant use of energy.

Even though some mode changes are anticipated, the major transportation structure is expected to remain basically unchanged. The importance of a highly developed fuel distribution system for transportation cannot be over emphasized. Without large quantities of fuel readily available throughout the country, the present transportation system would collapse. Even if the energy necessary to operate the transportation system is available, unless the form of the energy carrier (fuel) is compatible with distribution and storage facilities, the energy is virtually useless. Hence, any study of transportation energy use must consider both the form of the fuel and its utilization by transportation vehicles.

TABLE 5-5
PRESENT AND EXPECTED NON-WORK
ORIENTED AUTOMOBILE TRAVEL

Travel Purpose	1970 Mileage (%)	1980 Savings (%)	Transfer to Commercial (%)
Family Business	24.6	15.0	4.0
Entertainment	18.6	10.0	2.0
Visits (friends and relatives)	12.2	10.0	3.0
Business Related	8.0	6.0	---
Vacation	2.5	1.5	0.5

C - 2

5.3.3.2 SPECIALIZED FUEL REQUIREMENTS FOR TRANSPORTATION

A fuel that is suitable for use in transportation vehicles must have certain basic properties that are not essential in a fuel to be used in a stationary consumption device. Energy intensive properties such as volumetric energy density (Btu/gal or Btu/ft³, cal/l or cal/m³) and mass energy density (Btu/lb, cal/kg) are important measures of the portability of the fuel. These properties provide a comparison of the relative size and mass required for a given quantity of energy using different fuels. In general, fuels having higher volumetric and mass energy densities are more desirable vehicle fuels.

A more concise picture of the basic fuel needs for a transportation vehicle can be obtained by listing the important properties. An idealized vehicle fuel should have:

- high volumetric energy density (Btu/gal, cal/l)
- high mass energy density (Btu/lb, cal/kg)
- high stability at normal atmospheric conditions
- easily transferability from large stationary storage facilities to on-board vehicle storage
- long storage life
- relatively inert and non-toxic properties in handling and use
- minimal pollution or health hazards from exhaust products when fuel is consumed.

Present vehicle fuels obviously do not meet all these idealized properties. It would be unrealistic to assume that foreseeable fuels for transportation vehicles will have all the desirable properties. However, an understanding of these idealized fuel properties will provide a more objective basis for comparison of various fuels for transportation use.

5.3.3.3 SYNTHETIC FUELS

In recognizing the possible shortage of light petroleum fuels such as gasoline and jet aircraft fuel, the concept of synthetic or manufactured fuels has again been considered during the last decade (5-32). Combined with the efforts to find clean burning fuels for pollution control (5-37) the search for an alternate fuel has yielded several candidates. In a very broad sense these candidate fuels can be separated into four categories:

- hydrocarbons (including alcohols)
- hydrogen
- inorganic hydrogen compounds (ammonia)
- electro-chemical (battery)

Of these four categories the hydro-carbon fuels have been investigated most extensively (5-33 through 5-40). Generally the light hydrocarbons such as methane (CH₄) and propane (C₃H₈) have superior emission characteristics (5-41) but are considerably more difficult to handle and store than gasoline type fuels. Although not yet economically feasible, several processes are available to convert coal to liquid and gaseous fuels (5-42 through 5-50). These processes appear to have a thermal efficiency of approximately 50 percent (5-51) with a possible increase to 70 percent. Thus, to produce one Btu of fuel, current conversion technology requires two Btu of raw material energy input. This is a rather inefficient use of our coal natural resource but probably a necessary one for relief of the short range and perhaps intermediate range fuel problems for transportation.

One of the more likely synthetic fuels made from coal and hydrogen that could replace gasoline is methyl alcohol (methanol). References available (5-33, 5-34, 5-35, 5-52) indicate that this fuel can be used directly or mixed with gasoline in current internal combustion engines. Depending on the gasoline-methanol mixture, some fuel system alterations might be necessary. Since the volume energy density of methanol is roughly half that of gasoline a question of equitable determination of selling price including associated road tax for gasoline-methanol mixtures must be answered. The emissions picture for methanol is not clear at this time. Gregory (5-52) cites the performance of a student designed vehicle using methanol fuel as surpassing the 1976 Federal Standards for carbon monoxide and oxides of nitrogen emissions. Brame (5-53) indicates that aldehydes and acids can be combustion by-products of methanol and these materials are not measured as pollutants in the Federal Test Procedure. The actual emission characteristics of methanol in internal combustion engines must be clearly determined before any large scale use can be considered.

Hydrogen as a fuel for transportation vehicles is not a new idea. Weil (5-20) cites the rather extensive developments made by Erren before World War II. During this war Erren's records were destroyed and the termination of the war made petroleum fuels readily available, thus eliminating the need for hydrogen fueled transportation. During the past 10 years the environmental pollution problem has led several investigators to re-examine the use of hydrogen as a vehicle fuel. Esher (5-54) has attempted to address the distribution and use problem for hydrogen as a fuel with oxygen. Most other investigators (5-55 through 5-58) have concentrated on the use of hydrogen as a fuel for the internal combustion engine. From this work it appears that hydrogen can be satisfactorily used as a fuel for internal combustion

engine. From this work it appears that hydrogen can be satisfactorily used as a fuel for internal combustion engines (hence transportation) with reasonable development work. However, the problems of distributing the hydrogen and carrying it on board the vehicle have not been satisfactorily solved. The two direct possibilities are to carry the fuel as a high pressure gas or a cryogenic liquid. In either case the problems and expense of distributing the fuel and storing enough on board for reasonable vehicle range are immense. Technical, economic, and safety problems make the direct use of hydrogen in gaseous or liquid form a virtual impossibility in all but a select few transportation media in the foreseeable future.

In an effort to utilize hydrogen as a vehicle fuel, the concept of storing the hydrogen in some chemical carrier has been developed. To date, work on these carriers falls into two major categories: inter-metallic compounds (metallic hydrides) and liquid hydride fuels (ammonia and hydrazine). Wiswall and others at Brookhaven National Laboratory (5-59) appear to have the most definitive work in using metallic hydrides for energy storage. Their work demonstrates that the technical feasibility for use of metallic hydride fuel storage probably exists. However, mass and volume energy density of the most promising compounds are poor and the rare materials needed for their manufacture preclude any large scale use. Until these problems are solved, metallic hydrides are a remote possibility for fuel storage.

Ammonia, a hydride of nitrogen, is familiar to most people. Its fuel potential (5-60, 5-61) has been examined as has that of other more exotic hydrides such as the boron hydrides; (5-62) and Silane (SiH_4). Of these hydrides, ammonia (NH_3) is the most promising for a synthetic fuel. Although it is toxic and a gas at normal atmospheric conditions it can be easily liquified and stored in pressurized steel containers with standard equipment and handling procedures. The volumetric and mass energy density are roughly half that of gasoline. With high energy ignition systems, ammonia can be used directly as fuel in an internal combustion engine at a sacrifice of power and fuel economy. Alternately, ammonia can be easily dissociated into hydrogen and nitrogen and the hydrogen burned as fuel with the nitrogen a diluent gas. Starkman's (5-60) work demonstrates the concept but does not carry the effort beyond 5 percent by weight of hydrogen (about 30 percent dissociation). Little work has been published concerning ammonia fuel since Starkman's (5-60) and Gray's (5-61) work. However, if energy and hydrogen are available for manufacture, ammonia may prove to be an important fuel for surface vehicle use.

One fuel supply-storage system that has minor use in the transportation industry today is the electric-electrochemical system. Generally this is considered to be the rechargeable storage battery. However, the fuel cell could just as well be put in this category. Unfortunately, the fuels used in fuel cells of today, such as hydrogen and methane, have not overcome their storage problems. In addition, the scarcity and high cost of materials required for fuel cell construction essentially eliminate it from consideration for most transportation modes. New developments in battery and electric vehicle technology (5-63 through 5-68) are making the battery powered electric vehicle more desirable for light duty use (automobiles and light commercial vehicles). It is worthwhile to note, that the electric automobile has virtually no local pollution. Of course, the power plant that generated the electricity stored in the battery may pollute, but even present fossil fuel plants produce less pollution per electric vehicle mile than controlled fossil fueled vehicles (5-64). If hydrogen is ultimately used to fuel local power plants in conjunction with battery operated light vehicles, a significant reduction in transportation related pollution will be observed.

It is unrealistic to attempt to summarize the synthetic fuels discussed because the application of any fuel in the transportation system will better measure its success or failure. Examination of the complex structure of our transportation system soon uncovers the fact that no single synthetic fuel will supply all needs. Hence, each transportation mode will probably adopt that synthetic fuel most appropriate and advantageous to its operation. Before examining the application of the different synthetic fuel possibilities to the various modes of transportation it is worthwhile to organize the properties of typical synthetic fuels into ready reference form. In order to do this the desirable features of a synthetic fuel are listed as follows:

- Synthetic fuel should be made from abundant resources (air and water)
- Consumption of synthetic fuel should return the components to their original state (air and water)
- Consumption of synthetic fuel should produce no pollution or health hazard
- Only energy, raw materials (air and water), and catalysts should be required to manufacture the fuel in a typical process plant
- The synthetic fuel should be stable at normal atmospheric conditions and either liquid or easily liquified gas.
- Liquid and vapor phases of the synthetic fuel should be relatively inert and non-toxic.
- No special handling problems should

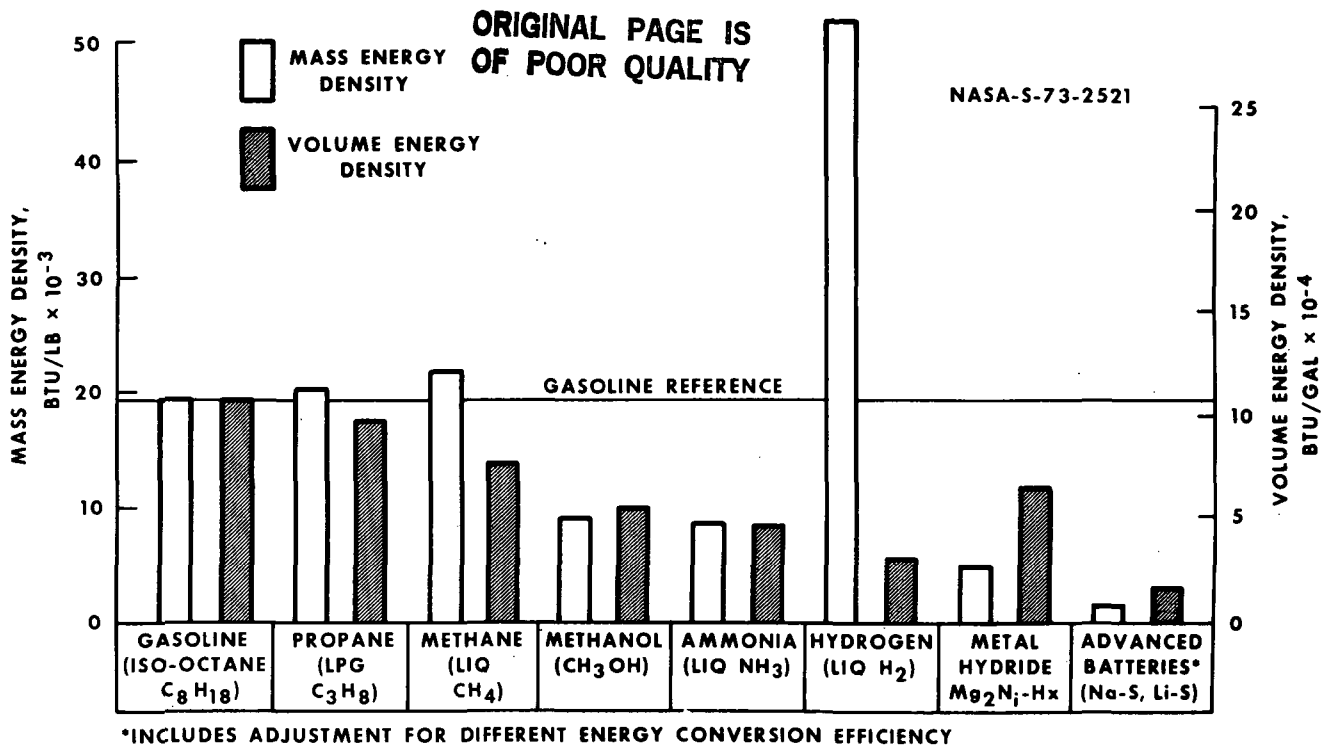

FIGURE 5-22
ENERGY DENSITY CHARACTERISTICS OF
VARIOUS TRANSPORTATION FUELS

**INTERNAL COMBUSTION ENGINE AUTOMOBILE ASSUMED FOR ALL
FUELS EXCEPT ADVANCED BATTERY SYSTEMS**

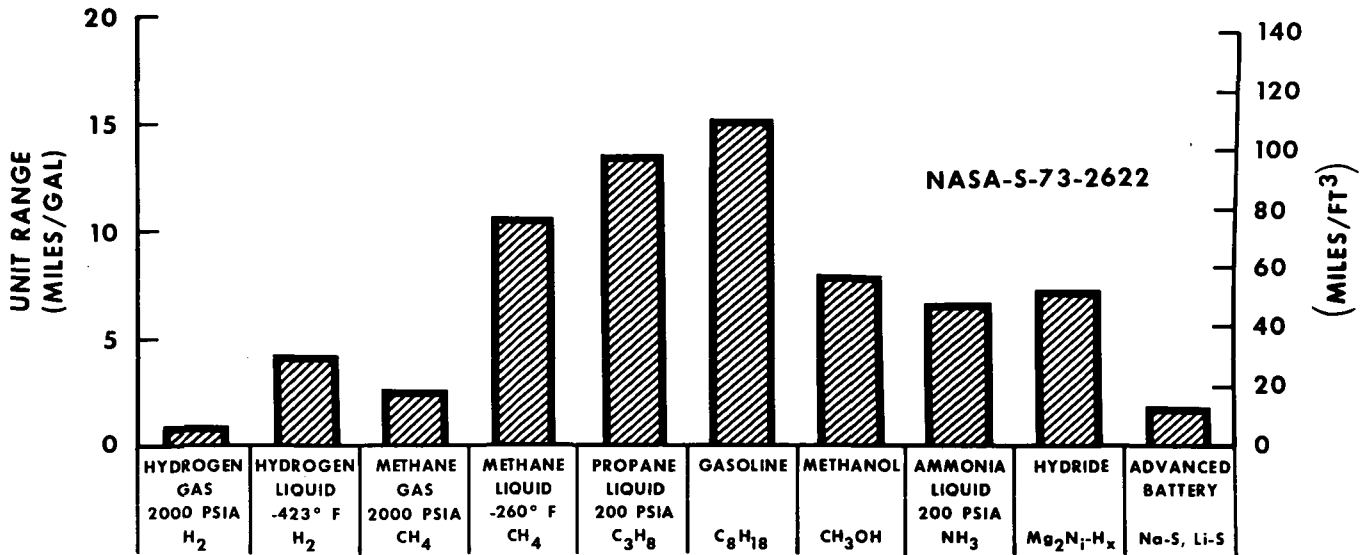

FIGURE 5-23
RELATIVE RANGE FOR SELECTED SYNTHETIC FUELS

exist for the synthetic fuel. (The material should be manageable like gasoline or liquified petroleum gas (LPG)).

Tables 5-6 and 5-7 were constructed by combining these properties with those listed in the previous section. These tables are designed to provide as direct a comparison as possible between the selected fuel candidates. Figure 5-22 and 5-23 amplify the importance of mass and volumetric energy density for transportation use.

5.3.3.4 APPLICATION POTENTIALS OF HYDROGEN AND OTHER SYNTHETIC FUELS TO VARIOUS TRANSPORTATION MODES

Aviation and Space

Aviation is divided into three major categories: general, commercial, and military. General aviation is primarily comprised of small aircraft with extremely variable operational and maintenance situations. These aircraft require a liquid fuel with high mass and volume energy density equivalent to the aviation fuels currently in use. The only synthetic fuel that offers any advantage for aircraft is liquid hydrogen which has 2.7 times the mass energy density of current fuels. However, the extreme diversification of general aviation aircraft and their use make the use of liquid hydrogen with all its storage and handling problems a very remote possibility for synthetic fuel. Rather, it appears that liquid hydrocarbons will be the main fuel for general aviation for some time.

In terms of fuel, operational and maintenance conditions, commercial and military aircraft can be considered together. The possible use of liquid hydrogen in these aircraft has distinct possibilities. However, consideration must be made to insure worldwide fuel availability. The significant weight advantages of the liquid hydrogen fueled aircraft, the possible shortage of jet fuel, and the environmental advantages of hydrogen are exerting strong pressure on the aerospace industry to consider liquid hydrogen as a fuel. The nature of commercial aircraft use minimizes the fuel loss due to boil-off by having the aircraft in the air a high percentage of the time. Although the fuselage of the aircraft will probably have the same basic wingspan and length as present commercial aircraft, lower gross vehicle weights will allow shorter takeoff distances, thus reducing the necessity for airports with extreme runway lengths. In terms of environmental impact the liquid hydrogen aircraft is much cleaner than its fossil fueled equivalent. The basic emissions are water and oxides of nitrogen. Oxides of nitrogen will probably be controlled with improved combustor design in turbojet engines. For

hydrogen fueled aircraft, the water vapor in the engine exhaust would be increased by a factor of about 2.7. For supersonic aircraft flying in the stratosphere, the problem of exhaust water vapor causing weather modification is a question that must be satisfactorily answered. The environmental impact of this increased water vapor in subsonic aircraft will be minor compared to the improvement in reduced carbon monoxide and hydrocarbons.

Space vehicles represent a very small portion of the energy consumed by aviation and space users. Since liquid hydrogen is already in use as a vehicle propellant in rocket engines, there is little question as to the feasibility and impact of its use.

Trains and Other Rail Vehicles

Intercity trains now rely basically on liquid hydrocarbon fuels for their operation. Some operations in the North-East transportation corridor utilize electricity, but these are a relatively minor portion of the national total. Trains are not volume limited for fuel storage and hence liquid hydrogen may be considered. However, the distribution and handling problems in the railroad industry make practical implementation of liquid hydrogen in the near future improbable and impractical. The most appropriate application of hydrogen to the rail industry is in fueling electric generating plants which serve electrified rail lines. This system would reduce pollution at both generation and rail sites. Present technology makes this approach suitable for local rather than long distance operations. Long haul trains will still be fueled with liquid hydrocarbons or perhaps ammonia.

Rapid transit operations including the Personal Rapid Transit (PRT) concept are very limited in their ability to utilize hydrogen directly as a fuel due to the storage, handling and safety problems. However, since many of these concepts are already employing electricity as the power supply system, the hydrogen fueled electrical generating plant which serves electrified rail lines shows even greater promise here. Hydrogen fuel reduces emissions and improves efficiency of local generating stations and electric power improves the emission and noise characteristics of the vehicles involved. Fossil fuels will serve as intermediate fuels for these systems until hydrogen is commercially competitive.

Road-Type Vehicles

The greatest portion of energy for transportation is utilized by road type vehicles including automobiles, trucks and buses. The present supply and distribution network for petroleum fuels is complex and diverse. It relies primarily on relatively unskilled labor to operate the storage and distribution facilities. To make liquid

TABLE 5-6
 PROPERTIES AND DESCRIPTION OF
 COMMON SYNTHETIC FUELS

FUEL	HYDROGEN LIQUID	METHANE LIQUID	PROPANE LIQUID	ISO-OCTANE	BENZENE	METHANOL	ETHANOL	AMMONIA	METALLIC HYDRIDE	PROJECTED BATTERY
CHEMICAL FORMULA	H ₂	CH ₄	C ₃ H ₈	C ₈ H ₁₈	C ₆ H ₆	CH ₃ OH	C ₂ H ₃ OH	NH ₃	Mg ₂ N ₁ -H _x	Na-S or Li-S
MOLECULAR WEIGHT	2	16	44	114	78	32	46	17	-----	-----
SPECIFIC GRAVITY (60°F) a,b,c	GAS (0.07) (@ Boil)	GAS (0.424) (@ Boil)	GAS (0.582) (@ Boil)	0.69	0.88	0.79	0.79	GAS (0.71) (@ BOIL)	-----	-----
MELTING POINT (°F) a,b,c	-435	-296	-304	-162	42	-144	-179	-108	-----	-----
BOILING POINT (°F) a,b,c	-423	-260	-44	211	177	149	173	-28	-----	-----
HEAT OF VAPORIZATION (Btu/lb) a,b,c	191	248	167	130	187	502	396	592	-----	-----
APPEARANCE c,d	Colorless, Odorless	Colorless, Odorless	Colorless Odorless	Colorless, Character- istic Odor	Colorless, Aromatic Odor	Colorless, Odor	Colorless, Character- istic Odor	Colorless, Pungent Odor	Sealed Container	Sealed Container
VAPOR TOXICITY c,d	Non- Toxic	Non- Toxic	Non- Toxic	Extreme Concentra- tion Causes Narcosis	Cumulative Anesthetic Toxicity, Irritant	Cumulative Toxic, Irritant	Toxic Only in Extreme Dose, Irritant	Toxic, Acts like alkali	Low Toxicity Primarily Irritant	Possible Caustic Compounds
STATE AT NORMAL ATMOSPHERIC CONDITIONS	Gas	Gas	Gas	Liquid	Liquid or Solid	Liquid	Liquid	Gas	Solid	Solid
CONDITIONS FOR LIQUID STATE	Cryogenic -423°F	Cryogenic -260°F	200 t psi @100°F	Normal ATM.	Temp. above 42°F	Normal ATM.	Normal ATM.	200 psi @ 100°F	-----	Operates As Molten Salt @ 550°F +
HANDLING c,d	Cryogenic Small Scale Commercial	Cryogenic STD. Commercial	Pressurized Liquid STD. Commercial	Liquid STD. Commercial	Liquid Small Scale Commercial	Liquid Small Scale Commercial	Liquid Small Scale Commercial	Pressurized Liquid STD. Commercial	Unknown, Hydrides Generally Very Reactive	Unknown, Operates With High Temp. Caustic

- a. information available in reference 5-76
- b. information available in reference 5-74
- c. information available in reference 5-75
- d. information available in reference 5-73

ORIGINAL PAGE IS
 OF POOR QUALITY

TABLE 5-7
FUEL CHARACTERISTICS OF COMMON
SYNTHETIC FUELS

FUEL	HYDROGEN LIQUID	METHANE LIQUID	PROPANE LIQUID	ISO-OCTANE	BENZENE	METHANOL	ETHANOL	AMMONIA	METALLIC HYDRIDE	PROJECTED BATTERY
VOLUMETRIC DENSITY (lb/gal)	0.59	3.53	4.86	5.75	7.35	6.60	6.60	5.93	14.3 _a	11.4 _b
VOLUMETRIC DENSITY (lb/FT ³)	4.37	26.4	36.3	43.0	55.0	49.3	49.3	44.3	107 _a	85 _b
MASS ENERGY DENSITY (Btu/lb)	51,600 _e	21,500 _f	20,000 _f	19,100 _f	17,200 _f	8,600 _f	11,600 _f	8,000 _e	3,660 _a	1,230 _{b,c}
VOLUMETRIC ENERGY DENSITY (Btu/gal)	3.0 x 10 ⁴	7.6 x 10 ⁴	9.8 x 10 ⁴	11.1 x 10 ⁴	12.6 x 10 ⁴	5.7 x 10 ⁴	7.6 x 10 ⁴	4.7 x 10 ⁴	5.2 x 10 ⁴ _a	1.3 x 10 ⁴ _{b,c}
VOLUMETRIC ENERGY DENSITY (Btu/FT ³)	0.23 x 10 ⁶	0.57 x 10 ⁶	0.73 x 10 ⁶	0.82 x 10 ⁶	0.94 x 10 ⁶	0.425 x 10 ⁶	0.57 x 10 ⁶	0.35 x 10 ⁶	0.39 x 10 ⁶ _a	0.1 x 10 ⁶ _{b,c}
STOICHIOMETRIC AIR-FUEL RATIO (lb Air/lb Fuel)	34.5 : 1 _d	17.2 : 1 _d	15.6 : 1 _d	15.1 : 1 _d	13.2 : 1 _d	6.4 : 1 _d	9.0 : 1 _d	6.1 : 1 _d	2.45 : 1 _g	-----
VAPOR FLAMIBILITY LIMITS (Volume %)	4 - 75 _h	5 - 15 _h	2.2 - 9.5 _h	1 - 6 _h	2 - 7 _h	7 - 36 _h	4.3 - 18 _h	16 - 27 _h	4 - 75 _g	-----
COMBUSTION AIR REQUIRED. (lb Air/Btu)	6.7 x 10 ⁻⁴	8.0 x 10 ⁻⁴	7.8 x 10 ⁻⁴	7.9 x 10 ⁻⁴	7.7 x 10 ⁻⁴	7.5 x 10 ⁻⁴	7.8 x 10 ⁻⁴	7.6 x 10 ⁻⁴	6.7 x 10 ⁻⁴ _g	29 x 10 ⁻⁴ _i
EXHAUST WATER (lb H ₂ O/Btu)	1.74 x 10 ⁻⁴ _d	1.05 x 10 ⁻⁴ _d	0.82 x 10 ⁻⁴ _d	0.74 x 10 ⁻⁴ _d	0.40 x 10 ⁻⁴ _d	1.31 x 10 ⁻⁴ _d	1.02 x 10 ⁻⁴ _d	1.98 x 10 ⁻⁴ _d	1.74 x 10 ⁻⁴ _g	3.0 x 10 ⁻⁴ _i
EXHAUST NITROGEN (lb N ₂ /Btu)	5.1 x 10 ⁻⁴ _d	6.1 x 10 ⁻⁴ _d	6.0 x 10 ⁻⁴ _d	6.0 x 10 ⁻⁴ _d	5.9 x 10 ⁻⁴ _d	5.8 x 10 ⁻⁴ _d	6.0 x 10 ⁻⁴ _d	6.9 x 10 ⁻⁴ _d	5.1 x 10 ⁻⁴ _g	22 x 10 ⁻⁴ _i
EXHAUST CARBON DIOXIDE (lb CO ₂ /Btu)	0 _d	1.27 x 10 ⁻⁴ _d	1.50 x 10 ⁻⁴ _d	1.62 x 10 ⁻⁴ _d	1.96 x 10 ⁻⁴ _d	1.60 x 10 ⁻⁴ _d	1.66 x 10 ⁻⁴ _d	0 _d	0 _g	5.9 x 10 ⁻⁴ _i
EXHAUST NITRIC OXIDE (lb NO/Btu)	6.7 x 10 ⁻⁶ _j	8.1 x 10 ⁻⁶ _j	7.1 x 10 ⁻⁶ _j	7.0 x 10 ⁻⁶ _j	10 x 10 ⁻⁶ _j	7.1 x 10 ⁻⁶ _j	6.7 x 10 ⁻⁶ _j	7.5 x 10 ⁻⁶ _j	6.7 x 10 ⁻⁶ _g	7.7 x 10 ⁻⁶ _k
EXHAUST CARBON MONOXIDE (lb CO/Btu)	0 _j	18.7 x 10 ⁻⁶ _j	18.1 x 10 ⁻⁶ _j	20.6 x 10 ⁻⁶ _j	24.8 x 10 ⁻⁶ _j	17.3 x 10 ⁻⁶ _j	18.9 x 10 ⁻⁶ _j	0 _j	0 _g	0.69 x 10 ⁻⁶ _k
EXHAUST HYDROCARBON (lb HC/Btu)	0 _l	0.6 x 10 ⁻⁶ _l	0.4 x 10 ⁻⁶ _l	1 x 10 ⁻⁶ _l	-----	-----	-----	0	0 _g	0.0013 x 10 ⁻⁶ _k
MANUFACTURING EFFICIENCY ($\frac{\text{Btu Fuel}}{\text{Btu Raw Mat'l Energy}}$)	0.5 _m	0.5 _n	0.5 _n	0.83 0.5 _o 0.5 _n	0.5 _n	0.66 _p	0.75 _{qq}	0.4 _r	0.5 _m	0.3 _i
VEHICLE EFFICIENCY ($\frac{\text{Btu @ Wheels}}{\text{Btu in Fuel Tank}}$)	0.126 _s	0.17 _s	0.18 _w	0.18 _w	0.18 _w	0.18 _w	0.18 _w	0.18 _w	0.17 _s	0.4 _t
TOTAL SYSTEM EFFICIENCY (Mfr. Eff. X Veh. Eff.)	0.063	0.085	0.09	0.15 0.09 _v	0.09	0.12	0.135	0.07	0.085	0.12

a. based on information in reference 5-59
b. based on information in references 5-68 and 5-65
c. corrected to vehicle drive efficiency of 65%
d. computed from information in reference 5-72
e. from reference 5-71
f. from reference 5-70
g. based on hydrogen as fuel
h. ref. 5-69
i. based on a coal fired electric generation plant with 30% efficiency to battery charger
j. based on stoichiometric combustion and data from ref. 5-33
k. from correlation of references 5-33, 5-64, 5-53, and 5-41

l. based on information from reference 5-41
m. based on probable conversion efficiencies of several hydrogen production processes
n. based on conversion of coal to liquid & gas by COED process ref. 5-51
o. based on current petroleum production ref. 5-13
p. based on conversion of coal from ref. 5-73
q. estimated from heat of formation & assuming 50% efficiency
r. estimated from heat of formation (50% eff. assumed) & hydrogen production eff.
s. I.C. engine efficiency plus losses due to liquefaction or compression of fuel
t. from ref. 5-67, charger to wheel efficiency
u. for petroleum based fuel
v. for coal based fuel
w. for typical I.C. engine automobile

hydrogen available as a road vehicle fuel will require enormous effort, capital and technician training for an entirely new distribution system. A more probable approach would use a significant portion of the present distribution system and a liquid or easily liquified gas for the synthetic fuel.

Long haul commercial vehicles (trucks and buses) will be more readily converted to synthetic liquid fuels such as synthetic petroleum or liquified ammonia. The number of final distribution points (truck and bus stops) is significantly less than that for the entire road vehicle transportation system and the general technical skill of vehicle and station operators is higher. Suitable economic, pollution, and fuel availability pressures could cause fuel changes in this area. Emission control can be obtained through a combination of fuel use and engine modification.

Local commercial vehicles can be classified generally as hauling and light delivery. Hauling type vehicles will require a high energy density fuel supply and will need to be fueled with liquid hydrocarbon or ammonia type synthetic fuels. As with long haul vehicles, emission control will probably be obtained through a combination of fuel use and engine modification. The short trip, multiple stop light delivery vehicle provides a strong case for the use of battery powered vehicles to conserve energy and meet local emission needs. In fact, electric delivery vans are now in production by several companies. Economics, pollution control, and fuel availability will play a large role in converting these delivery vehicles to electric operation. In terms of noise and other environmental impact the change will be favorable, particularly if increased local electric power demand is met with hydrogen-fueled generation facilities.

The automobile is much like the local delivery vehicle in terms of range and operation. Current use patterns indicate that 91 percent of automobile trips are 20 miles or less and account for 53 percent of vehicle miles (5-16). With the strong trend to two or more cars per family, the concept of the local commuter vehicle is gaining popularity. Assuming three or less 20 mile trips per day, the small electric runabout can be projected to have the range and performance necessary to be a satisfactory commuter vehicle. Improved battery technology should make this type of vehicle actually more efficient in terms of total energy use than a vehicle fueled with synthetic liquid hydrocarbons made from coal. In terms of noise and pollution, the electric commuter car will be a substantial improvement over the fossil fuel engine car.

Synthetic liquid fuels will be needed for the long range touring type automobile. Initially, these will be familiar liquid hydrocarbon fuels with the possibility of a synthetic fuel, such as ammonia, as technology and economics change. Fuel use and engine modification will be used to reduce the emissions of these vehicles to an acceptable level.

Agricultural and Construction Vehicles

Agricultural and construction vehicles will rely on synthetic liquid fuels for the foreseeable future. The relatively small number of vehicles and the problem of distributing and storing fuel over scattered areas will make the use of liquid hydrogen very remote for this area of use. The very poor energy density of batteries eliminates them from consideration for these vehicles. Due to the critical nature of this type of vehicle, particularly in agricultural use, available fossil fuels will probably be used on a priority basis here rather than in personal automobiles, etc. Although the farm industry is probably the best equipped to implement the use of ammonia as a fuel, only severe shortages or adverse political pressure will promote the use of ammonia over fossil fuels due to the increased capital costs and reliability of ammonia systems. The relatively small number of vehicles will make less of an environmental impact than road type vehicles.

Watercraft

Ocean going vessels will be difficult to convert to hydrogen or ammonia fuel. The volume and boil off problems associated with liquid hydrogen will decrease cargo volume and range. Ammonia requires twice the volume and twice the weight as liquid hydrocarbon fuels, also limiting cargo and range. In addition, the increased capital and maintenance costs of ammonia engines does little to encourage use of this synthetic fuel. Until economic or political pressures change significantly, liquid hydrocarbon and nuclear fuels will probably be the primary energy sources for ocean-going vessels. The pollution problem caused by fuel consumption of ships is very minor and will have minor impact in terms of current pollution problems. In view of demonstrated nuclear power for ships and the probability of breeder reactors, which generate nuclear fuel, the long term possibility for nuclear powered ocean-going vessels is good.

Inland commercial barges are moved by a pusher unit which is small compared to the barges of the "tow". Doubling the size and/or weight of this vehicle imposes no major problem in operation or loss of cargo capacity. Shortage of liquid fossil hydrocarbon fuels and political regulation could move this type of operation toward

**ORIGINAL PAGE IS
OF POOR QUALITY**

the use of ammonia type fuel and perhaps in the long term, liquid hydrogen. As in virtually all transportation cases, handling and distribution of the fuel will be the greatest problems for both ammonia and hydrogen. The impact of a fuel change for these vessels will be very small in terms of atmospheric pollution and other consideration.

Recreational Vehicles

Recreational vehicles will be very difficult to convert from liquid hydrocarbon fuels. The handling, distribution and safety problems for ammonia and hydrogen fuels will be greatly compounded by the fact that untrained and unskilled operators will be handling the fuel. The remote use location of many recreation vehicles and the extreme variation in configuration and use (trail bikes and outboard motors to motor homes) make anything but an easily handled liquid fuel an unlikely possibility. Thus, liquid hydrocarbons will probably be the primary fuel for recreational vehicles. Emission and other environmental restrictions plus increasing scarcity of liquid hydrocarbon fuels will probably act to limit the growth of recreational vehicles, until some suitable alternate fuel is developed. One possible route is for the use of different fuels for different recreational vehicles. Large motor homes and cabin cruisers would probably rely in the long term on a synthetic fuel, such as ammonia. For small vehicles such as trail bikes, a high cost vegetable base fuel such as ethyl alcohol (ethanol) would be a feasible long term fuel.

Small Power Plants

Small portable power plants found in lawn mowers, chain saws and the like suffer all the problems in fuel use of safety, distribution and inexperienced handlers that recreation vehicles have. For these powerplants anything but an easily handled liquid fuel is impractical. Many minor applications, such as lawn mowers and garden tractors, may be better handled with electric power. In fact, the energy efficiency of electrical devices for these applications is significantly greater than that for small combustion engines. The impact of electric equipment for home use (lawn mowers and garden tractors) would have a favorable effect on local noise and air pollution. For those applications like chain saws where electric power is unavailable, vegetable based ethanol could be justified as a long term fuel in spite of its relatively high cost.

5.3.4 ELECTRIC POWER GENERATION USAGE

5.3.4.1 ENERGY USE PATTERNS

In as much as the useful output of the

electric generation industry has already been accounted for within the other user areas in Figure 5-1, the electric power generation area in Figure 5-24 will be

NASA-S-73-2827

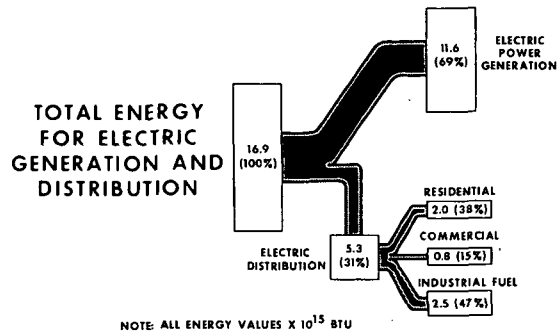
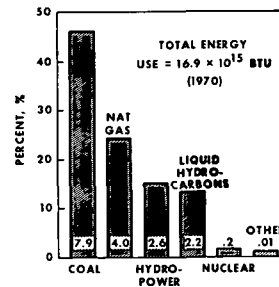

**FIGURE 5-24
ELECTRIC DEMAND PATTERNS, 1970**

defined as that energy which shows up as rejected heat from total energy for electric generation and distribution. This is 69 percent of the input energy for generation and distribution in Figure 5-24.

Electric power generating energy is obtained from various sources. A percentage and quantity breakdown for 1970 is presented in Figure 5-25. Note that a total of 83 percent of the energy is derived from fossil

NASA-S-73-2505



**FIGURE 5-25
COMPARISON OF SOURCE FUELS
FOR TOTAL ELECTRICAL ENERGY, 1970**

fuels. Environmental and scarcity factors are a pressing reminder that other forms of fuel must in the future represent a much larger portion of the energy sources.

The demand for electrical energy in

the user area has grown rapidly in the past (7 percent per year), due to the convenience and active promotion of this form of energy. Since the user determines the energy need in electric power generation, the respective area demands define the future needs for this area. Note that the block labeled electric power generation in Figure 5-24 is the quantity of concern in this section; however, the amount in this block is directly determined by the quantities in the user areas. The demand for electrical energy has increased largely due to requirements for space conditioning and electrical convenience devices in the residential and commercial area. To determine the future demand for electric power generation, demands in the user areas are projected. Of the present residential energy, 16 percent is supplied by electricity. This is expected to increase to 30 percent by 1985 and to 35 percent by 2020. This change in the demand is due to the increasing use of electrical devices in the residential area. The commercial area use of electricity is anticipated to grow at the commercial growth rate of 3.5 percent per year and industrial-fuel usage is to continue at an established rate of 3 percent annually. Summation of these three projections yield a saturation curve presented in Figure 5-26.

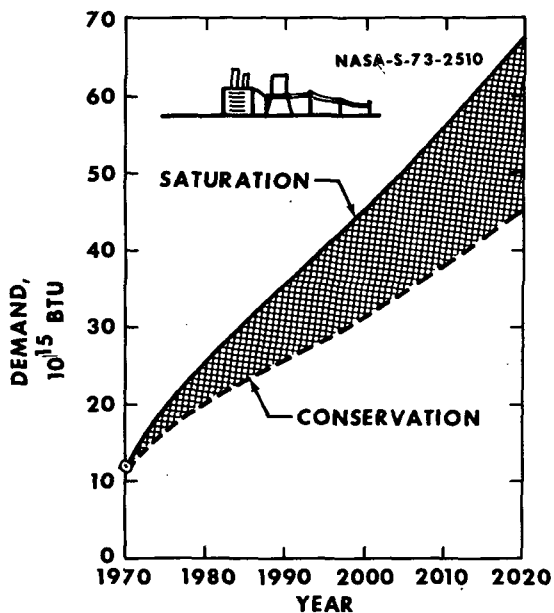

FIGURE 5-26
SATURATION AND CONSERVATION DEMAND FOR
ELECTRIC POWER GENERATION, 1970-2020

Future conservation in the area will be possible, dependent upon conservation in the user areas. More conscious use of electricity by the consumer will definitely reflect in decreased use in electric power generation. The conservation curve of Figure 5-26 allows that 50 percent of the savings due to residential and commercial area conservation will be reflected in this area. The industrial-fuel savings of

10 percent are transferred to a like savings in electric power generation. In 1985, approximately 25 percent of the generation demand can be conserved by these measures.

Energy demands in this area are of course modified by any efficiency changes in generation, but only small overall changes are anticipated. Overall conservation of energy is possible by the use of heat rejected from the generation process. This heat can fulfill requirements for heating; however, this possibility is not reflected in the demand for electric power generation energy pictured in Figure 5-26.

5.3.4.2 FEASIBILITY OF USING HYDROGEN

Several possibilities are available to successfully use pipelined gaseous hydrogen to generate electricity. The five most attractive follow:

- Conversion of existing boilers
- The aphodid burner - Rankine cycle
- An air breathing Rankine cycle boiler system specifically designed for hydrogen
- Hydrogen fueled gas turbines
- Other hydrogen fueled internal combustion engines.

The fuel cell has not been included in this list since it does not appear sufficiently developed to be practical for large-scale electric generation.

Conversion of existing steam power plant boilers to hydrogen fuel should prove relatively simple. Some of the considerations of change-over, however, are given below.

Consideration must be given to the compatibility to hydrogen of existing fuel pipelines with associated devices. More metallurgical research must be carried out before it is possible to predict metallurgical reliability. However, initial evidence indicates that present steel piping systems may be adequate, at least in a low temperature environment. Stainless steels may be needed in higher temperature regions such as near a burner.

Present natural gas and fuel oil burner systems will need replacement with units specifically designed for hydrogen. Coal fired boilers would need more extensive boiler modification to install hydrogen burners. A study by the U. S. Bureau of Mines (5-26) has indicated that flame blow-off or flash-back occur whenever hydrogen velocity falls outside the limits shown in Figure 5-14. These limits are rather wide, however, and pose no problem to burner designers.

Since the luminous characteristics

of burning hydrogen are quite different from those of conventional fuels, all flame-out detectors of the present photoelectric type will need replacement with devices that can sense a hydrogen flame-out condition.

Pilot lights and boiler draft systems may also need modification. Overall system efficiency and electric power output are not expected to change significantly due to conversion.

If oxygen as well as hydrogen is available, the present Rankine cycle plant can utilize the aphodid burner concept. As stated previously, this system utilizes a hydrogen-oxygen combustor to produce steam at high temperatures, thereby replacing the present boiler. The resulting system will be far more compact and should be significantly more efficient. By incorporating hydrogen cooled turbine blades in such a cycle, General Electric Corporation hopes to raise turbine inlet temperature to 2480°K with system efficiencies of up to 60 percent (5-18). A third electric generation facility which shows promise is the construction of totally new plants specifically designed to burn hydrogen-air mixtures. This system is similar to the conversion of existing boilers, but it allows designers more freedom to utilize the favorable burning properties of hydrogen. Hydrogen-air plants will be smaller, less polluting, and have quicker response than fossil fueled plants. They will, however, be much larger and less efficient than an aphodid burner plant. Rockwell International has performed preliminary studies on similar types of burners. These plant types employ cryogenic liquids, adding unnecessarily to fuel cost when compared to a gaseous-fueled aphodid burner (5-17).

The three preceding hydrogen systems apply chiefly to large electric generating facilities between 100 and 1000 megawatts. Smaller generating plants, emergency generating units, and peaking plants usually require very fast response with lower power output. Gas turbines and diesel engines are often used to fulfill this need.

Here again hydrogen shows excellent feasibility for use as a fuel to generate electricity. As described previously both gas turbines and reciprocating engines have demonstrated favorable performance characteristics using hydrogen as a fuel. Since stationary power plants need not rely on stored fuel, as is the case in transportation, the use of a gas turbine and reciprocating engines for power generation is possible. No metallurgical, efficiency, or reliability problems have yet been identified that would impede the utilization of either of these prime movers.

Overall feasibility of conversion from

fossil fueled to hydrogen fueled electric power generation looks quite good. Technology for conversion is either existing or appears attainable within a few years. Only an aphodid burner system with burner exit temperatures above 1400°K appears to require longer development periods.

5.3.4.3 IMPACT EVALUATION

The economic impact of conversion to hydrogen as a fuel for electric generation is quite complex; however, some generalizations can be made with good probability.

First the conversion cost for any existing plant will vary depending upon the unique features of that plant. Steam power plants are one-of-a-kind units rather than packaged products. Therefore, any change-over will require a significant expenditure of engineering time. We feel this cost along with projected scarcities of hydrogen will delay the conversion of existing plants.

In contrast to the above, the installation of a new aphodid burner plant has a more favorable economic outlook. Not only can it use available hydrogen more efficiently, it also has the potential to be available in factory assembled sub-assemblies rather than a field assembled plant. At present the labor for field assembly represents about one-half the cost of a new nuclear power plant (5-74). Cost savings associated with factory assembled sub-assemblies should provide the economic stimulus needed to develop a practical aphodid burner system.

It appears that hydrogen-air steam plants to not have a size favorable to factory sub-assembly; however, they should be no larger than the fossil fuel counterpart and therefore should have a comparable economic outlook. Another stimulus for the hydrogen-air plant is its nonreliance on oxygen.

Hydrogen-air steam plants could be the first large facilities to use hydrogen to generate electricity, closely followed by aphodid burner plants.

Although long term evaluations have not been made, at this time no serious engineering problems are foreseen in developing reliable hydrogen fueled gas turbine and stationary internal combustion engines. Therefore, the economic picture for utilizing these devices in power generation should be as favorable as for fossil fueled devices excluding any differences in fuel cost.

Air quality can be expected to improve directly with increased hydrogen utilization in the electric generation industry. Neither carbon nor sulfur compounds would be emitted from a hydrogen fueled plant.

Oxides of nitrogen generation appear to be less in a hydrogen plant and, in fact, it appears that NO_x may be easily controlled by burning lean fuel-air mixtures. Hydrogen plants will generate larger quantities of water vapor than comparable fossil fuel plants. However, since water vapor is essentially the only emission, it can be easily condensed.

The aphodid burner plant would have no exhaust except water since it uses oxygen rather than air as the oxidizer. This added feature makes the aphodid plant a very desirable facility.

Hydrogen gas fueled turbines and reciprocating I-C engines also appear to have excellent emission characteristics (5-19). Tests at Oklahoma State University (5-56) confirm that high power performance is possible with reduced NO_x emission levels, when compared to similar fossil fueled engines. Carbon and sulfur compounds are absent from this exhaust.

The safety of using hydrogen in the electric power generation industry should pose no unusual problems. If leak detectors and special flame-out detectors are used in conjunction with good engineering design and workmanship, no unusual hazards should develop. In fact, the electric generating industry has been using hydrogen for many years as a heat transfer agent in large generators without serious problems.

In general, the electric power generation industry appears to be the most favorable market for hydrogen fuel. The economics of designing and operating a limited number of large plants is unquestionably better than converting the entire residential and commercial market to hydrogen use.

5.3.5 INDUSTRIAL-CHEMICAL USAGE

5.3.5.1 ENERGY USE PATTERNS

The industrial-chemical area does not present a true demand for energy, but requires the use of fossil resources as raw materials in the production of goods. The demand curve will represent the equivalent energy contained in these end products, some examples being:

- Ammonia
- Plastics and resin materials
- Synthetic rubber
- Lubricating oils
- A diversity of products such as medicines and perfumes

Growth in the industrial-chemical area has been 6 percent per year in the recent past. This rapid growth has resulted from the many new products derived from fossil materials and a growing demand for these products. Anhydrous ammonia is an example of a major industrial-chemical product. Ammonia production has increased

from 4,818,000 tons in 1960 to 13,719,000 tons in 1970 (5-75).

The demand for products derived from the traditional fuels used as raw materials can be expected to increase as the use of fertilizers and convenience consumer goods increases. The anticipated growth rate, however, will decrease from the present 6 percent per year to 3 percent in 1985 due to limits in the amount of these goods which can be utilized beneficially. The saturation curve of Figure 5-27 reflects this decreasing growth.

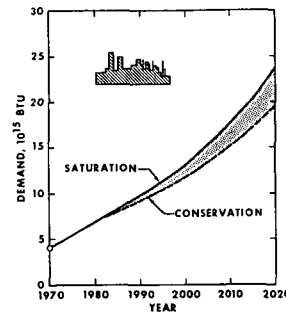

FIGURE 5-27
SATURATION AND CONSERVATION DEMAND FOR
INDUSTRIAL-CHEMICAL, 1970-2020

A more conservative projection results when consideration is made of a fossil material shortage and the effects of these synthetic products on the environment. Under these conditions the growth rate is expected to decrease to 2.5 percent. This conservation curve is projected in Figure 5-27.

5.3.5.2 FEASIBILITY OF USING HYDROGEN

Hydrogen is produced and used extensively in the industrial chemical field at the present time. This hydrogen is used in specific manufacturing processes in the individual plants. Some of the uses are:

- The hydrogenation of coal, to convert it into lubricating oils and gasoline,
- The manufacture of ammonia (Figure 5-28) for the production of fertilizer and to a lesser extent as a fuel,
- As a hardener for animal and vegetable oils, (hydrogenation), so they can be used in foodstuffs and soap,
- Hydrogenation of benzene to hexane, to be used in the manufacture of nylon,
- Reduction of iron ore to manufacture steel,
- The manufacture of methyl alcohol

that can be used as a solvent or as a fuel,

- Various laboratory purposes.

NASA-SP-70-3455

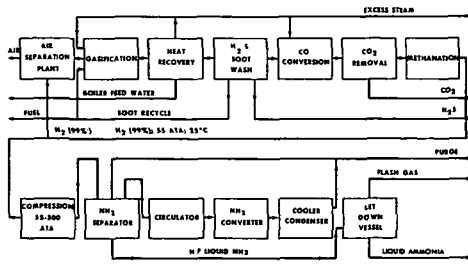

FIGURE 5-28
AMMONIA PROCESS WITH FUEL GASIFICATION PLANT AND AIR SEPARATION

It is feasible to supply processes utilizing hydrogen as an intermediate chemical from a hydrogen utility system, where hydrogen is produced by large central hydrogen plants and distributed in the same fashion as natural gas, water and electricity.

5.3.5.3 IMPACT EVALUATION

The most important aspect of a change-over from self-produced hydrogen to a utility hydrogen will be the release of fossil fuels. Approximately 3 percent of the total U. S. consumption of fossil fuels annually is used in hydrogen production by industry. The base resources used to produce hydrogen consist primarily of natural gas and naphtha. These two fuels can be released from hydrogen production and used in some other area to help optimize the use of our fossil fuels.

Safety will not be impaired nor will any new problems be posed in the industrial-chemical fields by the introduction of pipelined hydrogen. Safety programs now exist at plants that use pipelined or hydrogen manufactured on-site. The removal of hydrogen production and storage from each individual user will reduce some existing hazards. The actual cost outlay to convert to utility hydrogen would be very minimal.

5.4 COMPATIBILITY OF HYDROGEN WITH ENGINEERING METALS

The effects of hydrogen on, and its compatibility with metals and alloys have been investigated for over 50 years but extensive work has been performed only in

the last two to three decades. The culmination of this work is thousands of publications concerning the interaction of hydrogen with metals. The work performed on the different aspects of hydrogen embrittlement has received several excellent reviews (5-76 through 5-78). Until the mid 1960's, it was convenient to divide this work into two broad classifications: hydrogen reaction embrittlement and internal reversible hydrogen embrittlement. Recent work has identified a different phenomenon which is called hydrogen environment embrittlement (Table 5-8).

The first class is characterized by embrittlement caused by chemical reactions of hydrogen with the metal or alloying constituents. This form of hydrogen embrittlement manifests itself in the formation of compounds such as metal hydrides, water, and methane. The methane reaction in which carbon in steel combines with absorbed hydrogen is well known in the petroleum industry. Formation of the methane gas internally in the steel leads to fissures, blistering, and cracking.

Another example of reaction embrittlement is the chemical combining of hydrogen with oxygen in solid copper. Water in the form of steam, the reaction product, causes cracking of the copper metal. The anhydrous ammonia industry is well aware of the detrimental effects of hydrogen caused by the combinations of high pressure and temperature that are required to produce its product.

The second classification of metal-hydrogen interaction is the well researched and discussed time delayed hydrogen embrittlement. Over 3000 articles have been published in this area. Even though the phenomena and the factors that influence it are well known, the exact mechanism is still not well defined. The phenomenon occurs by the absorption of hydrogen in the form of a monoatom or ion into the internal structure of the metal. After an interval of time, which can be as long as years, catastrophic failure of the metal results. The hydrogen in this case can come from many sources, particularly metal processing procedures such as electroplating, melting, or welding.

In the mid 1960's another type of hydrogen embrittlement appeared unexpectedly in the aerospace industry (5-79, 5-80). Several storage tank failures, due obviously to hydrogen environment, were not explainable by either of the prior two classifications. The term hydrogen environmental embrittlement was given to this type of failure. This phenomenon is characterized by the formation and growth of surface cracks in a metal or alloy while being plastically deformed in a high purity hydrogen gas environment. Laboratory failures of many different engineering metals and alloys have been produced at hydrogen pressures

TABLE 5-8
 CHARACTERISTICS OF THE TYPES
 OF HYDROGEN EMBRITTLEMENT

CHARACTERISTICS	TYPES OF EMBRITTLEMENT		
	HYDROGEN ENVIRONMENT EMBRITTLEMENT	INTERNAL REVERSIBLE HYDROGEN EMBRITTLEMENT	HYDROGEN REACTION EMBRITTLEMENT
USUAL SOURCE OF HYDROGEN	GASEOUS (H ₂)	PROCESSING } (H) ELECTROLYSIS } CORROSION }	GASEOUS OR ATOMIC HYDROGEN FROM ANY SOURCE
TYPICAL CONDITIONS	10 ⁻⁶ TO 10 ⁸ N/m ² GAS PRESSURE MOST SEVERE NEAR ROOM TEMP OBSERVED -100° TO 700° C GAS PURITY IS IMPORTANT STRAIN RATE IS IMPORTANT	0.1 TO 10 PPM AVERAGE H CONTENT MOST SEVERE NEAR ROOM TEMPERATURE OBSERVED -100° TO 100° C STRAIN RATE IS IMPORTANT	HEAT TREATMENT OR SERVICE IN HYDROGEN, USUALLY AT ELEVATED TEMPERATURES
CRACK INITIATION	(SURFACE OR INTERNAL INITIATION) ^a	INTERNAL CRACK INITIATION	USUALLY INTERNAL INITIATION FROM BUBBLES OR FLAKES
RATE CONTROLLING STEP	ADSORPTION = TRANSFER STEP (ABSORPTION OR LATTICE DIFFUSION) ^a = EMBRITTLING STEP	LATTICE DIFFUSION TO INTERNAL STRESS RAISERS	CHEMICAL REACTION TO FORM HYDRIDES OR GAS BUBBLES

^aUNRESOLVED

of one atmosphere and higher. It has been only in the late 1960's and early 1970's that significant research studies have been carried out on this type of failure. The work of Jewett, et al. (5-78) is an excellent comprehensive review.

A general analysis of how hydrogen embrittlement phenomena can affect the use of materials can be made in the following way. First, it must be understood that almost all hydrogen embrittlement phenomena are dependent at some point on the presence of mono-hydrogen atoms in the environment. It is now generally recognized that hydrogen cannot enter a metal or alloy in the form of molecular hydrogen, H_2 ; only mono-atoms or ions can enter. However, it must be equally recognized that a molecular hydrogen gaseous environment is always in equilibrium with a certain amount of mono-hydrogen atoms as shown by the following reaction:

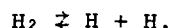

At ambient conditions there is an extremely small number of mono-atoms present in gaseous hydrogen and general effect of hydrogen on metals is insignificant. However, the reaction above is moved to the right when temperatures are raised above ambient conditions. Therefore, at temperatures and pressures greater than ambient conditions more hydrogen embrittlement problems are encountered. This fact is well known in the petroleum, petrochemical, and anhydrous ammonia industries where severe combinations of pressure and temperature produce significant hydrogen embrittlement problems.

In a hydrogen economy many devices can be expected to operate at high temperatures, which cause molecular hydrogen to be dissociated into the mono-atomic form. Therefore, a much greater range and amount of hydrogen embrittlement failures will be encountered. The hydrogen reaction type of embrittlement will become more acute, because of the increased rates of chemical reactions and diffusion through metals at these elevated temperatures. Embrittlement problems of this nature are normally reduced or alleviated by the use of alloyed steels. There will need to be a more general use of nickel, chrome, and stainless steels in hydrogen burning devices. The increased use of these more expensive metals and alloys will ultimately cause an increase in the price of many machines and processes that use hydrogen.

The problems resulting from hydrogen embrittlement of metals must be recognized, but should not be a cause for pessimism about the future uses of hydrogen. The petroleum and petrochemical industries have learned to provide for these problems and there is no reason to believe other industries cannot adequately deal with them. The hydrogen embrittlement problem is not one

which will prevent the realization of a hydrogen economy, but it is a problem which will need constant awareness in order to build and operate viable machines and processes.

5.5 SYSTEM IMPLEMENTATION

5.5.1 CONVERSION SEQUENCE

A number of considerations must be made to implement a changeover from a fossil fuel to a hydrogen based economy. The main emphasis must be on conservation of domestic fossil fuels. This implies a commitment to conserve fuel forms which are in short supply and expensive imports. These factors lead to an order of importance of fuels: natural gas, liquid hydrocarbons (petroleum), and coal. When a decision is necessary in any particular fuel application, the use of synthetic hydrogen fuel must be emphasized. This will conserve the fossil fuels for maximum future use in areas where hydrogen is impractical.

A sequence of conversion to hydrogen fuel is actually governed by a number of practical considerations:

- Availability of hydrogen at the user location
- Economic implications of the fuel change
- Effect of a fuel change on factors such as efficiency and environment
- Safety capabilities of the user.

Even though these are not exclusive factors nor are they ordered by importance, they do serve as a guide to the conversion sequence.

The first available hydrogen should be placed into the industrial-chemical category. Even though this is a small overall utilization area, each pound of synthetic hydrogen will replace about eight pounds of methane currently used to produce chemical hydrogen. The time, equipment, and safety and handling requirements required for changeover will not be a factor of significance, since hydrogen from a fossil source is presently being used.

Industrial-fuel and electric power generation have approximately equal priority for hydrogen supply once the industrial-chemical market is satisfied. Each pound of hydrogen thus used will replace nearly three pounds of hydrocarbons. The period during which hydrogen production grows to meet and exceed the needs of the industrial-chemical market should prove sufficient for progressive changeover of existing industrial and electrical generation equipment. The first plants to convert would be those presently using natural gas. Later a replacement for liquid hydrocarbons would occur.

A complete conversion of commercial units would imply a serious economic problem. Changeover of all fuel consuming appliances and the associated plumbing, as well as the fuel distribution of system, would probably pose an unrealistic economic burden. In contrast, however, multi-story urban buildings (university campus, office buildings, hospitals, etc.) with centrally located utilities is advantageous both to the supply system and to adaptation for adequate safety measures.

The residential market will probably be the last large fuel area that will show large scale convertibility to hydrogen usage. The large scale simultaneous changeover of all use devices will present many difficulties. New residential construction, especially sizable subdivisions or new cities, would appear to be a likely market for hydrogen distribution.

With the exception of space vehicles and possibly large aircraft, direct hydrogen utilization within the transportation sector will probably be insignificant within the foreseeable future. Practical adaptation of the small mobile power plant to hydrogen does not appear technically feasible from a fuel storage consideration. Present technology offers no hope for large scale, direct hydrogen use in transportation. As previously pointed out, secondary synthetic fuels such as ammonia, methanol or synthetic gasoline manufactured from hydrogen and coal may become future motor fuels. However, losses associated with the generation of these fuels suggests that, at least for the near future, fossil fuels will be used.

Increased use of electric vehicles will reduce the demand on fossil fuels and transfer this load to hydrogen fueled electric power generation facilities.

The actual timing of the conversion to a hydrogen as an energy source will depend on a large number of factors. Figure 5-29 shows the amounts of energy convertible to the hydrogen economy.

5.5.2 IMPACT OF SYSTEM IMPLEMENTATION

Once a basic decision has been made to use hydrogen as an energy carrier, an extensive education and training program should be undertaken to prepare society for system implementation. Education should proceed first to familiarize the populace with the general properties of hydrogen; then to dispel unfounded fears while instilling safe usage habits; and finally to promote public acceptance of a hydrogen energy system. Technician and craftsman training can be provided by workshops and short courses. With the

exception of liquid hydrogen handling, no extensive new techniques or materials will be encountered; therefore, training periods for qualified personnel should be brief. Environmental air quality in urban regions should improve with the increased use of hydrogen. Emissions from automobiles will continue, however, reduced emissions from the industrial, residential, commercial, and electric utility sectors will result in an overall air quality improvement.

NASA-5-73-2497

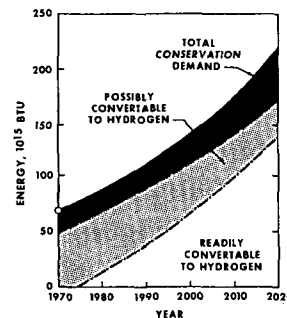

FIGURE 5-29
FORECAST OF HYDROGEN
CONVERTABILITY, 1970-2020

5.6 CONCLUSIONS

The task of changing to the use of hydrogen will be quite difficult; however, the alternative to this scheme (or some unforeseen alternate) is a society with insufficient energy resources. The difficulty, therefore, is secondary to the feasibility of changeover. Fortunately, this feasibility when viewed from a systems approach appears quite favorable. Direct changeover of surface transportation is the only sector that appears impractical. Electric power generation, industrial-chemical use, and industrial-fuel consumption all appear to have excellent conversion possibilities.

The technical capability of changeover within the residential and commercial sector exists, however, economic and fuel availability factors will affect the rate of conversion. Material compatibility and public acceptance pose interesting problems, but probably need not impede system implementation. Safety considerations will be different for hydrogen but probably no more stringent than present. Overall air quality will improve as the combustion of hydrogen replaces that of fossil fuel.

In summary, it is recommended that conservation efforts be immediately implemented. In addition, extensive research and development efforts should be undertaken to adapt present energy systems to hydrogen fuel.

SELECTED REFERENCES

- 5- 1 Morrison, W. E., "An Energy Model for the United States, Featuring Energy Balances for the Years 1947 to 1965 and Projections and forecasts to the Years 1980 and 2000", Bureau of Mines, IC-8384, July, 1968.
- 5- 2 Szego, G. C., "The U. S. Energy Problems", Volume I, Summary Volume, NSF RANN 71-1-1, Intertechnology Corp., November, 1971.
- 5- 3 Szego, G. C., "The U. S. Energy Problem", Volume II, Appendices Volume, NSF RANN 71-1-2, Intertechnology Corp., November, 1971.
- 5- 4 Hirst, E., "Energy Consumption for Transportation in the U. S.", ORNL-NSF-EP-15, Oak Ridge National Lab, March, 1972.
- 5- 5 Winger, J. G., "Outlook for Energy in the United States to 1985", Chase Manhattan Bank, June, 1972.
- 5- 6 Briefings Before the Task Force on Energy, Committee on Science and Astronautics of House of Representatives, August, 1972.
- 5- 7 Lueck, D. W., "Energy and the Environment", General Electric TEMPO Report 72TMP-57, December, 1972.
- 5- 8 Kelly, R., Reynolds, R. A., "Energy Supply and Demand Political Implications", General Electric TEMPO Report 72TMP-51, December, 1972.
- 5- 9 "U. S. Energy Outlook: A Summary Report of the National Petroleum Council", National Petroleum Council, December, 1972.
- 5-10 Morris, D. N., "Future Energy Demand and its Effect on the Environment", Rand, R-1098-NSF, September, 1972.
- 5-11 "The National Energy Outlook", Shell Oil Publication, March, 1973.
- 5-12 McKetta, J. J., "Today's Energy Sources- Their Projected Life", Paper presented at Symposium for Industrial Users of Natural Gas, April, 1973.
- 5-13 Hirst, E., "Energy Intensiveness of Passenger and Freight Transport Modes: 1950 to 1970", ORNL-NSF-EP-44, April, 1973.
- 5-14 "A Review and Comparison of Selected United States Energy Forecasts", Battelle Memorial Institute, December, 1969.
- 5-15 Austin, A. L., et al, "Energy: Uses, Sources, Issues", UCRL 51221, Lawrence Livermore Laboratory, May, 1972.
- 5-16 "The Potential for Energy Conservation: A Staff Study", Office of Emergency Preparedness, October, 1972.
- 5-17 Hughes, W. L., and Brauser, S. O., "Energy Storage Systems", U. S. Patent No. 3459953, August 5, 1969.
- 5-18 Hausz, W., Leeth, G. and Meyer, C., "Eco-Energy", General Electric TEMPO, Report 729206.
- 5-19 "Rocket Power to Light the Cities", Skyline Magazine, V. 30, n. 4, 1972.
- 5-20 Weil, K. H., "The Hydrogen I. C. Engine - Its Origins and Future in the Emerging Energy-Transportation-Environmental System", 1972 Intersociety Energy Conversion Engineering Conference, Paper No. 729212, San Diego, California.
- 5-21 Gregory, D. P., "A Hydrogen-Energy System", American Gas Association, August, 1972.
- 5-22 Scott, R. B., et al, Technology and Uses of Liquid Hydrogen, Pergamon Press, 1964.
- 5-23 Bernard, L. and vonElbe, G., Combustion, Flames and Explosions of Gases, Academic Press Inc., 1961
- 5-24 Drell, I. L., and Belles, F. E., "Survey of Hydrogen Combustion Properties", NASA 1383, 1958.
- 5-25 Rosen, B., Dayan, V. H. and Proffit, R. L., "Hydrogen Leak and Fire Detection", NASA SP5092, 1970.
- 5-26 Coward, H. F. and Jenks, G. W., "Limits of Flammability of Gases and Vapors", U. S. Bureau of Mines, Bulletin 503, 1952.
- 5-27 Austin, L. G., "Fuel Cells", NASA SP120, 1967.
- 5-28 Martini, W. R., "Developments in Stirling Engines", Paper presented at the ASME Winter Annual Meeting, New York, August 2, 1972.
- 5-29 Meijer, R. J., "Philips Stirling Engine Activities", SAE International Automotive Engineering Congress, Paper No. 650004, Detroit, Michigan, January 11-15, 1965.
- 5-30 Murray, R. G., Schoeffel, R. J., "Emission and Performance Characteristics of an Air-Breathing Hydrogen-

- Fueled Internal Combustion Engine", 1971 Intersociety Energy Conversion Engineering Conference, Paper No. 719009, Boston, Mass., 1971.
- 5-31 "Patterns of Energy Consumption in the United States", Stanford Research Institute for the Office of Science and Technology, January, 1972.
- 5-32 Lindel, K. O., et al, "Energy Depot Concept", SAE SP-263, 1965.
- 5-33 Starkman, E. S., et al, "Alternate Fuels for Control of Engine Emissions", J. Air Pollution Control Assoc., V. 20, p. 87, February, 1970.
- 5-34 Hetrick, S. S., "The Effect of Oxy-Hydrocarbon Fuels on Exhaust from Spark Ignition Engines", Dissertation Abstracts, Science & Engr., Vol. 28, no. 6, p. 2401B, December, 1967.
- 5-35 "Alcohols and Hydrocarbons as Motor Fuels", SAE SP-254, June, 1964.
- 5-36 Carr, R. C., Starkman, E. S., "The Influence of Fuel Composition on Emissions of Carbon Monoxide and Oxides of Nitrogen", SAE paper 700470, 1970.
- 5-37 "LP-Gas for Engines", SAE SP-285, December, 1966.
- 5-38 Swartz, D. J., et al, "Merits of L.P.G. Fuel for Automotive Air Pollution Abatement", J. Air Pollution Control Assoc., V. 13, p. 154, April, 1966.
- 5-39 Fleming, R. D., "Propane as an Engine Fuel for Clean Air Requirements", J. Air Pollution Control Assoc., V. 22, n. 6, June, 1972.
- 5-40 "The Seminar on Natural-Gas-Fueled Vehicles", Gas Scope, 15, March-April, 1970.
- 5-41 Lee, R. C., Wimmer, D. B., "Exhaust Emission Abatement by Fuel Variations to Produce Lean Combustion", SAE Paper 680769, October, 1968.
- 5-42 White, D. J., et al, "To Treat and Crack Oil from Coal", Hydrocarbon Process, V. 47, n. 12, pp. 97-102, 1968.
- 5-43 "Coal-Future Source of 'Synthetic' Fuels?", Chemical & Process Engr., p. 3, May, 1971.
- 5-44 Mills, G. A., "Conversion of Coal to Gasoline", Ind. Eng. Chem., V. 61, n. 7, pp. 6-17, 1969.
- 5-45 "Synthetic Fuels, What, When?", Chemical Engr., p. 62, April 17, 1972.
- 5-46 Cochran, N. P., "Gasoline from Coal", Proc. Ill. Mining Inst., V. 74, pp. 31-43, 1966
- 5-47 Hellwig, K. C., et al, "Convert Coal to Liquid Fuels with H-Coal", Chem. Engr. Progr., Symp. Ser. V. 64, n. 85, pp. 98-103, 1968.
- 5-48 "Synthetic Liquid Fuels from Oil Shale, Tar Sands, and Coal", Hydrocarbon Symposium, Quart. Colb. School of Mines, V. 65, n. 4, October, 1970.
- 5-49 Hoffman, E. J., "Coal Conversion and the Direct Production of Hydrocarbons from Coal Steam Systems", Natural Resources Research Inst., College of Engr. University of Wyoming, August, 1966.
- 5-50 Qader, S. A., "Production of Synthetic Fuels from Coal by Hydrogenation under Medium Pressures", Amer. Chem. Soc. Div. Fuel Chem., V. 12, n. 3, pp. 164-80, 1968.
- 5-51 Shearer, H. A., "Economic Evaluation of COED Process Plus Char Gassification", Dept. of Interior Office of Coal Research Contract no. 14-32-0001-1210, Govt. Stk. no. 2414-00052.
- 5-52 Gregory, D. P., and Rosenberg, R. B., "Synthetic Fuels for Transportation and National Energy Needs", paper presented at SAE meeting May 15, 1973, avail. Inst. Gas Tech, Chicago, Illinois, 60616.
- 5-53 Brame, J. S., and King, J. G., Fuel Solid, Liquid and Gaseous, 6th Ed., St. Martins Press, N. Y., 1967.
- 5-54 Esher, W. J. D., "On the Higher Energy Form of Water (H₂O*) in Automotive Vehicle Advanced Power Systems", 7th IECEC, San Diego, California, 1972.
- 5-55 Swain, M. R. and Adt, R. R., "The Hydrogen - Air Fueled Automobile", 7th IECEC, San Diego, California, 1972.
- 5-56 Murray, R. G., Schoeppel, R. J., & Gray, C. L., "The Hydrogen Engine in Perspective", 1972 Intersociety Energy Conversion Engineering Conference, paper no. 729216, San Diego, California.
- 5-57 Billings, R. E., and Lynch, F. E., "History of Hydrogen - Fueled Internal Combustion Engines", publication 73001, Energy Research Co., Provo, Utah, 1973.

- 5-58 Billings, R. E., and Lynch, F. E., "Performance and Nitric Oxide Control Parameters of the Hydrogen Engine", Publication 73002, Energy Research Co., Provo, Utah, April, 1973.
- 5-59 Wiswall, R. H., and Reilly, J. J., "Metal Hydrides for Energy Storage", 7th IECEC, San Diego, California, 1972.
- 5-60 Starkman, E. S., et al, "Ammonia as a Spark Ignition Engine Fuel: Theory and Application", SAE Trans., V. 75, n. 660155, p. 765, 1967.
- 5-61 Gray, J. T., et al, "Ammonia Fuel - Engine Compatibility and Combustion", SAE Trans., V. 75, n. 660156, pp. 785-807, 1967.
- 5-62 Adams, R. M., "The Boranes or Boron Hydrides" (Boron Hydride Structure, preparation, physical and chemical properties with application as high energy fuels), Boron, Metallo-Boron Compounds and Boranes, Interscience Pub., N. Y., 1964.
- 5-63 Hietbrink, E. H., and Tricklebank, S. B., "Electric Storage Batteries for Vehicle Propulsion", ASME Paper 70-WA/Ener-7, 1970.
- 5-64 Hamlen, R. D., and Christopher, H. A., "Battery Power and Energy Density Requirements for Vehicle Propulsion", General Electric Co. Rpt. No. 71-C-306.
- 5-65 Herbert, G. F., and Anderson, A. E., "Power Requirements of Electric Vehicles", SAE Paper 710238, January, 1971
- 5-66 Laumeister, B. R., "The G. E. Electric Vehicle", General Electric Co. Rpt. No. 68-C-128.
- 5-67 Hines, E., et al, "Effect of Electric Vehicles on the Power Industry", SAE paper 690441, 1969.
- 5-68 Cairns, E. J., et al, "Development of High-Energy Batteries for Electric Vehicles", Argonne National Lab, Illinois, Chemical Engineering Division, AP&D 0875, PB205254, 1971.
- 5-69 Sax, N. I., Dangerous Properties of Industrial Materials, 3rd Ed., Van Nostrand Reinhold Co., New York, 1968.
- 5-70 Lichty, L. C., Internal Combustion Engines, 5th Ed., McGraw-Hill Book Co., New York, 1939.
- 5-71 Handbook of Compressed Gases, Compressed Gas Association, Inc., Reinhold Publishing Corp., New York, 1966.
- 5-72 Perry, J. H. ed., Chemical Engineers' Handbook, 4th Ed., McGraw-Hill Book Co., New York, 1963.
- 5-73 "Hydrogen and Other Synthetic Fuels" (A Summary of the Work of the Synthetic Fuels Panel), AEC, TID-26136, September, 1972.
- 5-74 Leeth, G. G., Personal Communication, TEMPO General Electric, July, 1973.
- 5-75 Lerner, William (Director), Statistical Abstracts of the United States, Department of Commerce, 1972.
- 5-76 Triona, A. R., Transactions of American Society of Metals, V. 52, p. 54, 1960.
- 5-77 Elsea, A. R., and Fletcher, E. E., "Hydrogen-Induced, Delayed, Brittle Failures of High-Strength Steels", Defense Metals Information Center, Report 196, January 20, 1964.
- 5-78 Jewett, R. P., et al, "Hydrogen Environment Embrittlement of Metals", Rocketdyne Div. of North American Rockwell, NASA CR-2163, March, 1973.
- 5-79 McPherson, W. B., and Cataldo, C. E., "Recent Experience in High Pressure Gaseous Hydrogen Equipment at Room Temperature", Technical Report No. 8-14.1, American Society for Metals, Metals Park, Ohio, October, 1968.
- 5-80 Laws, J. S., Frick, V., and McConnel, J., "Hydrogen Gas Pressure Vessel Problems in the M-1 Facilities", NASA CR-1305, Washington, D. C., March, 1969.

ADDITIONAL REFERENCES

- Cermak, J., "World Survey of Ammonia Plants", British Chemical Engineering, V. 14, n. 6, p. 813-818, June, 1969.
- Cloyd, D. R., Murray, W. J., "Handling Hazardous Materials", NASA SP-5032, 1965.
- Egerton, A. C., Limits of Inflammability, Williams and Wilkens, Baltimore, 1953.
- Grummer, J., Harris, M. E. and Rowe, V. E., "Fundamental Flashback, Blow Off, and Yellow-Tip Limits of Fuel-Gas-Air Mixtures", U. S. Bureau of Mines, Report 5225, Washington, D. C., 1956.

Huff, J. R., "Seventh Status Report on Fuel Cells", U. S. Army, AD755106, 73N20048, Report No. 2039, Oct., 1972.

Philpot, J. & Davey, B., "Wasserstoff in Der Industries", Kaltetechnik-Klimatisierung, 22 Jahrgang, Heft 11/1970.

Scott, R. B., et al, Technology & Uses of Liquid Hydrogen, Pergamon Press, 1964.

Van Den Berg, G. J., & Van Lookeren Campagne, N., "Hydrogen as a Raw Material in the Chemical Industry", Advancement of Science, pp. 364-374, June, 1971

Wild, R., "Iron Ore Reduction Processes", Chemical & Process Engineering, pp. 55-61, Feb., 1969.

Zabetakis, M. G., Safety with Cryogenic Fluids, Plenum Press, New York, 1967.

CHAPTER 6
SAFETY, LEGAL,
ENVIRONMENTAL,
ECONOMIC, POLITICAL,
AND SOCIAL ASPECTS OF
HYDROGEN

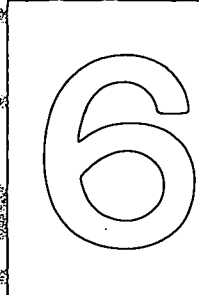

ORIGINAL PAGE IS
OF POOR QUALITY

6.1 INTRODUCTION

The achievement of a good may entail the simultaneous production of a bad. The unintended and unexpected consequences of actions may be at least as important as the intended and expected consequences. Certainly the realization of a technical goal creates repercussions in nontechnical areas. David (6-1) has said that national programs in many areas, including energy, ". . . must address not only a technological problem, but also an economic problem, a social problem, legal, political and environmental, and perhaps even a moral problem as well." In recognition of this fact, we have attempted to include in our study of the hydrogen energy system some preliminary estimates of how that system would impact upon and be impacted by society. These estimates are very definitely preliminary; the subject area is enormous. There are many ways in which society will change during the next decades, and there are many ways in which hydrogen may, or may not, be incorporated into our energy system.

It is a hallmark of the technological society that we define problems and then set about solving them, rather than asking if the condition is really a problem or only defined as such, and whether we might be better off living with it. To a technological society, the fact that we seem to have developed more energy demand than we can supply is a problem, and the obvious solution is to build more power plants. Further, due to social and intellectual inertia, the type of plant we decide to build is probably the type to which we are already accustomed or growing accustomed, rather than something new and unusual. The results of the demand projections in Chapter Five constrain us to recommend that Americans approach the problem of energy from both sides: provision of new energy and learning to live with restraints. We should seek to optimize, not maximize, our energy systems. We discuss here some social, legal, economic, environmental, political and safety aspects of energy and of hydrogen as an energy carrier.

6.2 SAFETY IMPLICATIONS

6.2.1 LEGAL ASPECTS

6.2.1.1 INTRODUCTION

Concern for safety in the United States energy system is an example of what may be called the principle of federated regulation. Federated in this context means a sharing of power among the Federal, state and local governments and private

units. Regulation means a rule or order guiding action and issued by a public (government) or private executive. Authority for safety is scattered between public and private decision makers and among Federal, state and local responsibility. It is also divided between safety programs designed to prevent accidents, and programs designed to repair losses resulting from accidents. Despite this diversity, two dominant features have stood out: First, because of a strong feeling in our policy for the reserved police power of the states over health, safety and general welfare, the states rather than the Federal government have had the primary and overwhelming responsibility; and second, because of equally strong adherence to economic doctrines of laissez faire, many safety decisions are fundamentally private. An example of the latter is that while a state or locality may require a certain level of safety by an energy company, the basic safety code imposed is no more than an industrial code, self-generated by the industry itself. Two recent Federal acts discussed below may radically change this picture in the very near future.

6.2.1.2 FEDERAL RESPONSIBILITY

While Federal responsibility over energy safety has been minimal, there are several areas in which the Federal government plays a dominant safety role. The first area is that of wholly Federally owned energy facilities. As of June, 1972, the Federal government owned about 42 percent (24.1 million kilowatts) of all the hydroelectric generating capacity in the contiguous United States (6-2). Since the Tennessee Valley Authority is a Federally owned and created energy facility, safety is primarily a Federal responsibility. Where energy takes on an interstate character, the Federal government will assume dominant regulatory responsibility. Of all the oil pipelines in the United States, 85.1 percent are regulated by the Interstate Commerce Commission (6-3). The Federal Power Commission has been authorized to regulate the interstate aspects of electrical and natural gas transmission, and thus has primary safety responsibility. The Atomic Energy Commission since 1946 has held pervasive authority over atomic energy. The enabling legislation is replete with Congressional concern for protection of the public health and safety. While no case has yet held that the Federal act has ousted state authority for safety decisions, there are some small indications that such may be the result (6-4).

Two recent Federal Safety Acts - The

Federal Coal Mine Health and Safety Act of 1969, (6-5) and the Occupational Safety and Health Act of 1970 (OSHA) (6-6) have substantially altered the traditional roles for safety legislation between the Federal and state governments. The 1969 Coal Mine Act introduced two brand new features into the United States energy system: first, it wrote into Federal law a comprehensive safety code for this energy industry; and second, it established the first entry by the Federal government into the repair aspect of safety legislation (thought heretofore to be an exclusive state prerogative) - Workmen's Compensation. Note that this legislation vitally affects the United States energy system as coal is now the main source of energy for electric generation plants, and is projected to become increasingly important as supplies of other fossil fuels diminish. As revolutionary as the 1969 Coal Mine Act was, the 1970 OSHA is positively radical. The act potentially (with some exceptions for governmental employers otherwise treated) covers all employers whose business affects interstate commerce. (As a footnote, virtually any business can be found to affect interstate commerce.) The Secretary of Labor is given the power to rule safety by administrative standards. While Congress did not preempt the states from retaining any authority over occupational health and safety, the political dynamics are such that the "OSHA eventually will be the primary force in the employee-safety field preempting contrary state action" (6-7) for "every industry in America". This is surely a radical first in American safety legislation.

6.2.1.3 STATE RESPONSIBILITY

By a large margin, the primary and overwhelming responsibility for safety legislation in the United States has been in the states. This is due to a very strong belief that, in our Federal system, the states have the traditional reserved power to protect and promote the health, safety and general welfare of its citizenry (6-8). Every state has enacted broad ranging safety codes, but weak programs and insufficient enforcement led to the 1970 OSHA (6-7 at p. 429). State energy codes are concerned mostly with job safety, equipment and the construction and use of materials in and around the home. Housing codes, however, are generally adoptions of privately generated codes. Another area of state energy safety code responsibility is the rather limited professional and trade codes, for example, the licensing of electricians. Trends indicate that there will be increased licensing and professional requirements for trades involved in the United States energy system.

Another area of state responsibility

for safety is that of state remedies for accidents. Every state has enacted a Workmen's Compensation system. These laws provide a low level, no-fault recovery for workers injured as a result of a job connected accident. For persons not workers (i.e., the public) injured by an energy related accident, the states also provide a common law tort remedy. These laws generally require proof of fault such as negligence or recklessness on the part of an agent of an energy supplier. Strict liability or a no-fault liability may be applied to extra-hazardous activities involving energy.

6.2.1.4 FEDERAL PREEMPTION - A DEVELOPING AREA

Of particular significance in the area of state safety responsibility is a recent first impression case decided by the United States Court of Appeals for the Eighth Circuit - Northern States Power Company v. Minnesota (6-8). There, the central question posed was whether the United States government had the sole authority under the doctrine of preemption to regulate radioactive waste released from nuclear power plants to the exclusion of any state authority. The Court reached an affirmative result and the case makes several important points. The case was pervaded with controversy because of the ever increasing demand for power tempered by ecological concerns and the ever-sensitive Pandora's box of problems in the area of Federal-State relations. The state, of course, asserted its traditional power under the Tenth Amendment to protect and promote the health, safety and general welfare of its citizens. Significantly, the Atomic Energy Act, as construed by the Court, did not expressly exclude state authority to control radioactive waste. The Court concluded that Congress had impliedly preempted the states from any regulation of health and safety in the level of radioactive effluents discharged from nuclear energy plants. This was felt to be so because Congress had vested the AEC with authority to resolve the proper balance between desired industrial progress and adequate health and safety standards, and that only through the application and enforcement of nationally uniform standards, promulgated by a national agency, could the dual objectives of industrial progress and adequate health and safety be met. The Court noted that should the states be allowed to impose stricter standards on the level of radioactive waste, they might conceivably be so over-protective as to unnecessarily stultify industrial development. This result was reached despite the fact that the conventional approach had been to recognize the legitimate interests of the states to protect the health and safety of its

citizens. Previously, courts had refused to find Federal preemption over state health and safety laws absent of clear and unmistakable expression. Preemption, on the other hand, was much more readily found in cases not involving public health and safety. Here, for the first time, it is suggested that where first, national interests are involved in a search for energy, and where second, there is thus a collision with the traditional power residing in the states to protect the health and safety of its citizens, and where, third, Congress has not expressly preempted state law, then finally, the Courts may find preemption in general Congressional legislation affecting energy use. This is truly startling.

Thus it may be seen from a comparison of the Federal-state areas of responsibility for safety that a trend is developing as follows:

- increased Federal responsibility in both safety codes and workmen's compensation; and
- the increased Federal regulation of safety will be to the preemption of state authority to set higher or different standards.

It is significant to note that the North-ern States Power Company case mentioned above involved atomic energy - one of the proposed prime energy sources to be used in the production of hydrogen. Should hydrogen enter the energy system, we can expect comprehensive Federal regulation of hydrogen and a comprehensive safety code. Also, should a conflict result between Federal and state authority over safety and health conditions connected with the use of hydrogen, we can expect that the courts, even in the absence of legislative expression, will find that Congress has preempted state authority.

6.2.2 POLITICAL ASPECTS

6.2.2.1 INTRODUCTION

Widespread public use of gaseous hydrogen in small units such as kitchen ranges, residential and commercial space heaters or refrigerators would require development of appliance safety standards and of additives for safety purposes. It must also be remembered that safe is a relative, judgmental term. Hydrogen must be evaluated relative to other fuels, not on an absolute basis, since all known fuels can be used only if a degree of risk is accepted.

6.2.2.2 ADDITIVES

Because people cannot ordinarily see

or smell hydrogen in its pure gaseous form, whether it is or is not burning, an additive would be required to provide a warning and leak detection method. Present users of hydrogen, such as NASA, typically require very high purity levels and, thus have not made use of odorants or illuminants as safety devices, relying instead on elaborate precautions and leak detection mechanisms. This would not be practicable for household use, but odorants and illuminants would serve well in the public market. Natural gas is now odorized in over half the states because of similar problems of leak detection, and several codes such as the NFPA or ASA provide standards. Natural gas odorants may be naturally occurring components of the gas (such as hydrogen sulfide or mercaptans) or may be added during processing.

Hydrogen could be used in residential or commercial applications for virtually any role now filled by natural gas: space heaters, water heaters, furnaces, kitchen ranges or refrigerators. For these purposes, odorants and illuminants currently used in natural gas could be used in the hydrogen distribution system. However, it would be desirable to direct research toward development of a new variety of additives. Two attractive applications of hydrogen, fuel cells and catalytic burning, would be reduced in efficiency or impossible if current additives were used. The fuel cell, which could be used in local electric power substations, operates most efficiently with pure hydrogen and pure oxygen. It is possible that odorizers could be added locally, after first supplying the fuel cell with pure hydrogen, so that both fuel cell efficiency and customer safety could be provided. Such additions may, however, prevent the use of hydrogen in a catalytic burner. Unfortunately, additives used today would poison the catalyst. Development of different additives or different catalyst materials should be undertaken.

An illuminant would be necessary for open flame hydrogen burners because hydrogen has a colorless and almost invisible flame in ordinary light. This makes it difficult to know whether a flame is present, thus increasing the danger of personal injury or ignition of materials (paper, dish towels, etc.) which might unknowingly be placed too close to a flame. Use of a suitable illuminant, or a more complicated and probably more expensive flame sensor, could reduce this danger.

6.2.2.3 APPLIANCE SAFETY STANDARDS

Safety standards and codes for natural gas appliances are well developed and could be adapted to hydrogen require-

ments. Some experience with hydrogen safety is in fact already available from the history of 'town gas' or 'producer gas', once widely used domestically and still common in Europe. Most such gas is a mixture of several elements and is typically approximately 50 percent hydrogen. Although town gas does not have exactly the same characteristics as would a hydrogen supply of the type contemplated in this report, it does provide some illustration of the fact that a properly-designed distribution and appliance system can be safely operated with a hydrogen-rich gas.

Adaptation of existing codes to accord with hydrogen's characteristics would probably accompany the development of hydrogen as a major new fuel. It would be necessary to carry out conversions on all burners, and in many cases whole new appliances would be either necessary or highly desirable for reasons of both safety and efficiency. This large-scale conversion coupled with the wide-spread public image of hydrogen as a dangerous substance seems likely to produce pressures for the development and elaboration of a comprehensive safety code on the Federal level.

The potential use of hydrogen-fueled furnaces or decentralized space heaters will require revisions in codes which may become extensive. Since the combustion of hydrogen results in water vapor and excess air, with only traces of nitrogen oxides, it would not be necessary to vent the combustion exhaust to the outside of the building. Current codes require venting of combustion products and various construction and safety requirements are premised on that venting. Changes in building and safety codes can become objects of major political combat in local areas, a fact which may either slow down the introduction of hydrogen as a fuel or provide more impetus to a comprehensive Federal code.

6.2.2.4 INDUSTRIAL USES AND SAFETY

Development of large-scale industrial use and transportation-storage of hydrogen is already present. NASA requirements for liquid hydrogen in the space program have resulted in considerable experience in transporting and storing large quantities. NASA has developed extensive safety procedures and training methods for personnel (6-9). Storage tanks, mobile transportation tanks and connector fittings have also been developed. There is no doubt that handling massive quantities of high-purity hydrogen in liquid form is dangerous but manageable, as NASA has not experienced a fatality in connection with liquid hydrogen. Other organizations, such as the Linde Corporation, manufacture

and transport or store hydrogen in both liquid and gaseous form and have found the safety problems real, but surmountable.

Large scale use of hydrogen, particularly in its more difficult liquid form, will require elaboration of these experiences into standardized safety and handling requirements. It is not improbable that Federal or state licensing requirements will be imposed upon personnel engaged in the transport and storage of liquid hydrogen. Large scale storage will give rise to requirements for fire protection such as those governing existing oil tank farms. Liquid hydrogen is already transported in over-the-road trailers and by rail tank car, with apparent safety.

Pipeline transmission of gaseous hydrogen has also been a standard practice for several years in the United States. One network of hydrogen pipelines in Germany dates from 1938 (6-10). Some safety problems with materials, such as the recently recognized hydrogen environment embrittlement, may become more significant with time and large scale use. Furthermore, any system tends to be more error-prone as it becomes more complex and extensive. Still, there is no apparent reason to believe that safety in hydrogen pipelines poses any insurmountable difficulties.

6.2.3 A DESCRIPTION AND ASSESSMENT

6.2.3.1 TECHNICAL

There is no point in denying the danger implicit in widespread use of hydrogen as an energy medium. Some of the key safety data are presented in Table 6-1, compared to natural gas (CH_4) and propane (C_3H_8).

We see that, compared to natural gas type mixtures, hydrogen is much more prone to leak (even through air-tight fittings); can be ignited by very low energy (even invisible static sparks); and is flammable over a very wide range of hydrogen-air mixtures. In liquid form, its extremely low temperature (below 20°K) can liquify any air which comes into contact with it, its tanks or lines. This produces fire and explosion hazard. Furthermore, a hydrogen-oxygen flame is invisible and a hydrogen-air flame is nearly invisible in daylight.

There are, however, some counterbalances to what appears to be a very damning list. It is true that hydrogen is more prone to leak than any other gas and that its diffusion rate is extremely high. But, since hydrogen will leak (diffuse) so very rapidly it may never reach a concentration sufficient to

TABLE 6-1
A COMPARISON OF SOME PROPERTIES OF THREE COMBUSTIBLE GASES (6-11)

	<u>H₂ (Hydrogen)</u>	<u>CH₄ (Methane)</u>	<u>C₃H₈ (Propane)</u>
Boiling Point (°K)	20.3	111.7	230.8
Lower Flammability Limit in Air (Vol %)	4.1	5.3	2.3
Upper Flammability Limit in Air (Vol %)	74.8	15.0	9.5
Lower Detonation Limit in Air (Vol %)	18.0	6.3	
Upper Detonation Limit in Air (Vol %)	59.0	13.5	
Ignition Temperature (°K)	850	807	736
Ignition Energy (milliJoules)	0.02 0.6 (at lower flammability limit)	0.3	0.25
Flame Temperature (°K) Air	2400	2190	2200
Flame Velocity (cm/sec)	275	37	41
Quenching Distance (cm) (one atm)	0.06	0.23	0.20
Air Required for Combustion, lbs of air/lbs of gas (295°K, one atm)	34.2	17.23	15.67

- NOTES: 1. Average thermal radiation from hydrogen flame is approximately one-tenth the radiation from hydro-carbon flames.
 2. Hydrogen diffuses through air 2.82 times faster than methane.
 3. Propane is a 'heavier-than-air' gas.

sustain ignition. Because it is only one-fourteenth as dense as air, hydrogen rapidly departs the scene of spills or leaks; gasoline, propane or fuel oil vapors, on the other hand, are heavier than air and tend to concentrate around a leak. Even natural gas diffuses only about one-third as rapidly as hydrogen. Very large hydrogen spills or leaks disperse so rapidly that the hazard would be past within minutes. A 500 gallon spill of liquid hydrogen diffuses to below flammability in about one minute.

Ordinary flames such as those from hydrocarbons release a great deal of radiant heat, while a hydrogen flame produces relatively little. This is a hazard in fighting hydrogen fires, because the flame is so nearly invisible and its radiant energy so low that one may actually walk into the flame before realizing it is there. This difficulty may be avoided

because a hydrogen fire in all probability may not be a pure hydrogen fire, but may involve foreign luminous substances. The lower radiant energy is potentially an advantage, since fire fighters could work closer to the flame or contain a blaze by removal or cooling of close-by flammable materials.

Hydrogen thus does present some special requirements for flame detection, materials handling, leak detection and safety in general. The fact that hydrogen is in widespread use in industry and the space program, as well as its common use over long time periods in town gas shows that it can be used safely. Union Carbide Corporation has been reported as believing that hydrogen is safer to handle than is gasoline or propane (6-12). We may confidently expect that a decision to develop large scale hydrogen fuel systems would be accompanied by the development of adequate

safety devices and techniques. Again, we must remember that natural gas, gasoline, and electricity are all dangerous energy forms, unless they are handled properly.

6.2.3.2 THE IMAGES: "HINDENBURGS AND "HYDROGEN BOMBS"

The literature on hydrogen is replete with references to the 1937 explosion of the German dirigible Hindenburg at Lakehurst, New Jersey. In fact, the term "Hindenburg Syndrome" is widely used as shorthand to indicate public identification of hydrogen as an exceptionally dangerous substance. There is an additional segment of the population who identify hydrogen with "that stuff bombs are made of" and are likewise concerned about the safety of hydrogen.

Derek Gregory (6-13) and many others have pointed out that the Hindenburg incident is greatly over-dramatized. In fact only 36 people were killed and 65 survived, a ratio and an absolute number which compares quite favorably with the results of a great many airplane crashes since 1937. The dirigible had made 18 round trips between its German home port and either the United States or Brazil without accident. While sabotage has been alleged, several safety provisions were violated at the time of the explosion. It may even be argued that the rapid burning characteristics of hydrogen and its low radiant energy led to the survival of more passengers than would otherwise have been expected. But, of course, the important point is that a public image was established and still, at least in part, persists. It is also true that there is no relationship whatever between a hydrogen-fueled kitchen range and a thermonuclear bomb; but some people may think that there is. These facts are important to remember, for opponents of hydrogen as an energy carrier may present an arsenal of objections based upon the images of the Hindenburg and the H-Bomb.

There is a conventional public education and public relations method which should be able to counter unfounded public fears about hydrogen. It is the truth. The H-Bomb image is so wildly at variance with fact that it can and should be easily corrected for all but the very few. The Hindenburg is rather more difficult. The dangers exemplified by that case are real and must be dealt with. It will be necessary to show that hydrogen dangers can be met and that safety standards can obtain acceptable risk levels.

6.2.3.3 CONCLUSION

Given the general concensus that

petroleum fuels are becoming rapidly depleted, and that their prices will rise, and given the powerful and still growing concern for environmental protection, American society may be faced with a trade-off in which a real risk of some increased danger will be exchanged for having energy in the quantities desired. This is not to say that hydrogen safety should not and cannot be developed until the incremental risk is rather low; it is, however, to argue that we cannot dismiss hydrogen simply because it is marginally less safe now than are other fuels to which we have become accustomed. Daily newspapers contain frequent reports of natural gas fires and explosions, seldom on the front page and usually in brief, one-day stories. The simple fact is that we do not know what the danger level of widespread hydrogen use would be, but we do know that the risk is an incremental risk, not an absolute one. It is the conclusion of our study that safety requirements can be met at acceptable costs.

6.3 LEGAL IMPLICATIONS

6.3.1 ENERGY LAW

6.3.1.1 INTRODUCTION

This section investigates the law of the United States energy system. The survey will cover the past and present in hopes of detecting trends so that some forecasts can be made about law's impact should hydrogen be introduced as an energy carrier. A constant in the system has been a demand for abundant, ever increasing quantities of low cost energy. Abundance was assumed as a fact and a value, and law reflected this. The law utilized to establish the rules of the road for the energy system was basically the English common law, but along the way some new and distinct developments were made. In short, law was called upon to assist in building the system, but was also affected by the system it created.

6.3.1.2 PROPERTY CONCEPTS AND OWNERSHIP

English common law concepts of property were borrowed. The concept of private property is prominent in the system, which is largely privately owned. There is, however, some public ownership. The Federal government, of course, owns a part of the energy system; for example the Tennessee Valley Authority and the numerous hydroelectric generation plants. Also, local governments, cities, counties and districts do have a substantial ownership role, primarily in the ownership of local electrical utilities. Singularly absent from any ownership role are the states.

The predominance of private ownership results in three features as follows:

- ownership is becoming highly concentrated, raising antitrust problems,
- ownership in private hands is assisted by the law of condemnation,
- the public interest demanded comprehensive regulatory schemes over private property.

6.3.1.3 ANTITRUST AND ENERGY MONOPOLY

During the 1960's a growing list of oil companies started acquiring interests in competing fuels. The result was intensive horizontal integration in the fossil fuel industry (6-14). For example, by 1970 of the 25 largest oil companies, 18 had involvements in oil shale, 11 in coal, 18 in uranium, and 7 in tar sands. This trend created what is now commonly called the "Energy Company". The Energy Company phenomenon has led to a renewed application of the antitrust laws to control the concentration of energy resources within a company. It should be noted, however, that it was long ago recognized that there must be many instances for natural monopolies, to wit the public utility. While this, of course, is quite contrary to basic notions of free enterprise competition, natural monopolies are very much a legal part of the American scene. Even so, a natural monopoly may be subject to antitrust action. In the recent case of Gulf States Utilities Company v. FPC, (6-15) the Supreme Court held that the FPC's broad regulatory authority over electric utility companies included the responsibility of considering possible anticompetitive aspects in authorizing a utility security issue. Responsibility was necessary, the Court felt, because it provided the first line of defense against anticompetitive practices which might later become subject to antitrust proceedings. Also, in another 1973 Supreme Court case, Otter Tail Power Company v. United States (6-16), the Court held that even though a utility may be quite highly controlled by a regulatory agency, it is nevertheless subject to independent scrutiny under the antitrust laws. This result was reached because repeals of the antitrust laws, by implication from a regulatory scheme, are to be strongly disfavored and have only been found, said the Supreme Court, in cases of plain repugnancy between the antitrust laws and the regulatory provisions.

On another antitrust front, the recent suit filed by the Florida Attorney General, charged 15 major United States oil companies with conspiring to violate the antitrust laws by creating a nationwide fuel

shortage. If successful, it could be the "biggest trustbusting attempt since the breakup of Standard Oil in the 1900's" (6-17). The suit alleges that the oil companies have engaged in an illegal monopoly and in unreasonable restraints of interstate commerce and trade. It also alleges that the oil companies conspired to reduce competition; raise, fix and stabilize prices and exclude nonmajor oil companies from significant aspects (e.g. refining and exploration) of the industry. The relief sought is that the companies be forced out of crude oil exploration and production. Furthermore, in July, 1973 the Federal Trade Commission accused the eight largest United States oil companies of monopolistic refining and marketing practices which have increased their profits, thus forcing American motorists to pay inflated prices. Paralleling the Florida suit, the FTC charged that the big oil firms have controlled the market from oil well to gas pump for the last 25 years, making it almost impossible for new companies to enter the refining business. The FTC action, in issuing an antitrust complaint, was termed unusual since it usually issues a proposed complaint, giving the parties involved a chance to settle the matter out of court (6-18).

All this renewed interest in application of the antitrust laws is sure to have a profound effect. The horizontally and/or vertically integrated energy company may be broken up into a severely atomized system. With capital investment costs approaching the limits of all but the largest company, it is anticipated that a vigorous application of the antitrust law to reduce company size may significantly hinder private entry into the hydrogen economy.

6.3.1.4 EMINENT DOMAIN

Of major importance is the ability of a company or government to condemn land necessary to carry on an energy activity. The common law of property has lent us the venerable concept of eminent domain. Its application in the United States, controlled by the Fifth Amendment, provides that private property shall not be taken for public use without just compensation (6-19). Just compensation is defined as the full monetary equivalent of the property taken. The owner should be placed in the same position, monetarily, as he would have been had his property not been taken (6-20). The monetary equivalent is determined by the concept of market value: the owner is entitled to the fair market value of his property at the time of the taking, and that the value is normally to be ascertained by what a willing buyer would pay in cash to a willing seller. Future energy needs in the nation indicate that substantial amounts of private property may have to be condemned, for which just

compensation must be paid. Proposals that hydrogen production plants be sited on land or that major new underground pipeline distribution systems be constructed will require that lands so taken be condemned, requiring substantial amounts of compensation. Offshore plant sites, thus derive an economic advantage - a factor which may join with environmental pressures and cooling water needs to create a rush to the sea.

6.3.2 REGULATORY LAW

6.3.2.1 INTRODUCTION

Perhaps the most significant aspect of the United States energy system has been the application of the principle of federated regulation. It is well known that the energy regulatory scheme in the United States is an almost indescribable, labyrinthian maze of maniacal confusion, overlap and conflict. We believe that the principle of federated regulation may help in understanding this mess.

6.3.2.2 FEDERAL REGULATION

Federal regulatory power is based upon the power conferred on Congress to regulate interstate commerce. The public interest in energy is generally defined as two-fold: First, to insure an efficient and dependable energy system to meet the needs of a growing national economy; and second, to serve the needs of consumers by insuring abundant, low cost, safe energy. These purposes may, however, conflict. Regulation of a company or industry to insure its viability and growth in an expanding economy requires promotion of the specific company of industry. The extent to which the company or industry is promoted may result in diminished concern for the needs of the consumers. Similarly, the reverse is true; the extent to which the regulatory agency sees its mandate as the protection of the consumer may result in harm to the company or industry. Two examples will serve to illustrate this problem.

The Atomic Energy Act was amended in 1954 for the specific purpose of encouraging private enterprise to assist in the development and utilization of atomic energy for peaceful purposes. In the recent case of Northern States Power Company v. Minnesota (6-8), a Federal Appeals Court noted that Congressional objectives in the 1954 amendments

evinced [a] legislative design to foster and encourage the development, use and control of atomic energy so as to make the maximum contribution to the general welfare and to increase the standard

of living (6-8, at p. 1153).

This is a pretty heady mandate and, as can be expected, consumer views tended to be lost. For example, in Crowther v. Seaborg (6-21), an objection was made to an extremely hazardous underground nuclear explosion testing the feasibility of nuclear stimulation of gases. Residents and landowners complained that the AEC had approved the test without full knowledge of the test's total impact. While the court sympathized with the fears of residents and landowners, the court supported the AEC's counter-argument that its job was to stimulate the use and development of atomic energy.

On the other hand, the regulatory agency may see its obligation to the consumer as primary. The result is abundant, low cost energy but a severely damaged industry. Such was the case with the Federal Power Commission and the natural gas industry. The FPC set such low rates for natural gas at the wellhead that an artificially high demand for the low-cost fuel was created. As markets expanded, exploration incentives were reduced. It has been asserted that this action contributed to the current shortages in natural gas. In its 1972 report, the FPC admits that

the Commission sought to rectify past regulatory practice so as to provide independent producers with the required financial incentives for investing the huge amounts of risk capital without which the exploration and development of gas reserves is impossible

and that

the prospective curtailments during the winter heating season of 1972-1973 offered harsh proof that capital formation during the past decade had failed to provide financial incentives adequate to spur domestic gas producers to explore and develop potential gas resources (6-2, at p. 1).

Federal regulation is not as comprehensive as one would think. In surveying the total energy resources in the United States, we can list coal, petroleum, natural gas, nuclear power, and hydroelectric power. The Federal regulatory agency involved in coal resources is the United States Bureau of Mines. Its authority is generally limited to the safety aspects of coal mining. The Federal government has made no attempt to regulate the price of coal, nor the siting or licensing of mines. The Federal agency involved in regulating petroleum resources is the Interstate Commerce Commission. The ICC regulates approximately 85 percent of all the inter-city ton miles of pipelined oil (6-3, at p. 146). Its main concern is with the orderly

movement and safety of the transportation process. The Federal agency involved in regulating natural gas is the Federal Power Commission. The Natural Gas Act of 1938 gave to the FPC broad powers to "protect consumers against exploitation at the hands of natural gas companies" (6-22) through a comprehensive and effective regulatory scheme of dual (state and Federal) authority. The Federal Power Commission's authority is limited to:

- transportation of natural gas in interstate commerce,
- its sale in interstate commerce for resale, and
- natural gas companies engaged in such transportation or sale.

The Federal agency involved in the regulation of nuclear energy is the Atomic Energy Commission. The Atomic Energy Act of 1954, amending prior acts, granted to the AEC broad powers over atomic energy to insure its proper development consistent with a concern for adequate health and safety standards.

Hydroelectric power resources are regulated by the Federal Power Commission. Its authority over nonfederal hydroelectric projects dates back to the agency's beginning in 1920. Of a total generating capacity of 57.4 million kilowatts, 24.1 million kilowatts is federally owned, 19.0 million privately owned, and 13.5 million nonfederal, publicly owned. Of the 33.3 million kilowatts of nonfederal capacity 29.4 million kilowatts (88 percent) is operating under FPC major licenses (6-2).

6.3.2.3 STATE REGULATION

As noted above, Congress has relied upon the states in many instances to supplement the Federal government's regulatory power. Even when Federal authority has been exercised, the usual pattern is a dual system of Federal and state authority. State authority is perhaps most pervasive in the coal mining industry where comprehensive safety codes, siting requirements and pollution standards abound. State residual authority in the petroleum industry is likewise quite comprehensive. A well known illustration is the powerful Texas Railroad Commission. We find in the areas of natural gas and electricity that the states retain the residual power of economic regulation, mostly by fixing consumer prices. Perhaps the most highly state-regulated aspect of the energy system is of electric power generation, distribution and sale.

After this brief survey of the American regulatory scheme, we can make some generalizations about the present, and some forecasts about the near-term future. As

detailed below, it is probably best expressed in two recent Supreme Court cases concerning the FPC.

6.3.2.4 CONCLUSION

In Otter Tail Power Company v. United States (6-16), the Supreme Court was presented with the question of a power company's refusal to deal with certain city corporations wanting to provide their own service to residents by purchasing, at wholesale prices, electrical energy produced by the company. While the case concerned the anticompetitive effect of the power company's refusal to deal, the Court noted that the Federal Power Act, though still allowed dual governance of economic decisions between the public sector (Federal government) and the private sector (private owners). Thus, as private ownership is maintained, commercial relationships are governed, in the first instance, by the private business judgment of the company. This result is so despite the fact that the company is a highly regulated natural monopoly. In other words, there is still a zone of freedom allowed by a regulatory act where private decision making is generally unregulated.

Similarly, there are many cases where Federal regulation is not exclusive, but rather shared with the states. Such an issue was recently involved in FPC v. Louisiana Power & Light Company (6-22). That case presented the fundamental question of whether or not the FPC was empowered by the Federal Power Act to take certain regulatory action over the Company. The Company argued that the FPC had no jurisdiction. The Supreme Court, construing the Natural Gas Act of 1938, noted that the FPC had been granted broad powers "to protect consumers against exploitation at the hands of natural gas monopolies". To that end Congress "meant to create a comprehensive and effective regulatory scheme" of dual state and Federal authority. The Court also noted that although Federal jurisdiction was not to be exclusive, FPC regulation was to be broadly complementary to that reserved to the states so that there would be no "gaps" for private interests to subvert the public welfare. Thus the question became: Which jurisdiction should fill the gap? To this question the Court answered that

when a dispute arises over whether a given transaction is within the scope of Federal or State regulatory authority, we are not inclined to approach the problem negatively, thus raising the possibility that a no man's land will be created. That is to say in a borderline case where Congressional authority is not explicit, we must ask whether State

authority can practically regulate the given area and if we find it cannot, then we are impelled to decide that Federal authority governs (6-22 at p. 1834).

Noting that there is inevitably a conflict between producing states and consuming states (which could create contradictory actions, regulations and rules that could not possibly be equitably resolved by the courts), the Court felt that a uniform Federal regulation was desirable. The Court, therefore, concluded that the matter in question was indeed within the jurisdiction of the FPC. The important fact from the case is that competition for energy among the states gives rise to a diversity of state resolutions, thus impelling the Court to find that the area is Federally regulated. This insures regulation in the national interest but diminishes the regulatory power of the states.

For a number of years, spokesmen for the energy industry have noted the need for a national energy policy and coordination among the various Federal and state regulatory agencies. Prompt action seems certain. For example, in early 1973 John J. McLean, chairman and chief executive officer of Continental Oil Company, called for a comprehensive national energy policy and the establishment of a cabinet-level energy committee (6-23). As early as March, 1971 President Nixon had proposed creation of a Department of Natural Resources, but Congress failed to enact that legislation. As recently as April, 1973 President Nixon again proposed the establishment of a cabinet-level agency entitled the Department of Energy and Natural Resources, which would be responsible for the balanced utilization and conservation of our nation's energy and natural resources. The proposed Department would consolidate many of the regulatory functions scattered throughout the Federal structure. Thus, it may be that the Federal and state regulatory structures will be, by and large, consolidated into a single Federal cabinet-level department. Surely, as the demand for energy increases and the supplies decrease, this agency will be given more and more functions of research, development, funding and regulation of the entire energy picture. In just two years, the name of the proposed agency had been changed from a Department of Natural Resources to a Department of Energy and Natural Resources thus indicating an expansion of conceived powers.

It may also be forecast that as the problems of energy use and supply become more critical, many functions will be taken away from the states by the Federal government. This is indicated by the Supreme Court's decision in FPC v. Louisiana

Power & Light Company where we found the United States Supreme Court saying that a Federal regulatory agency, in effect, abhors an energy system vacuum. It is also illustrated by Northern States Power Company v. Minnesota where the Eighth Circuit held, in a first impression decision, that a state's traditional power under the Tenth Amendment to protect and promote the health, safety and general welfare of its citizens, must give way to a uniform national policy for the development and utilization of nuclear energy. It thus seems rather clear that decisions in a hydrogen economy will be almost entirely federalized.

6.3.3 ENVIRONMENTAL LAW

6.3.3.1 INTRODUCTION

One of the most dramatic and recent developments on the American scene has been the growth of environmental concern. It has been suggested that environmental activism began in the 1950's, when the focus was on atmospheric nuclear testing, moved to pesticides in the sixties (6-24), and finally in the seventies to national policy. On January 1, 1970 President Nixon signed into law the National Environmental Policy Act (6-24). NEPA has been called the most important piece of environmental legislation ever written and will surely have a major impact on energy decisions in the future. Representative Casey (Texas) recently noted that Congress may have created a monster bent on government by agency fiat (6-26). In this section of the report we seek to survey Federal, state and private environmental law controls.

6.3.3.2 FEDERAL LAW

The most important Federal environmental law, the National Environment Policy Act (NEPA) (6-24), declares that it is the policy of the Federal government...

to use all practicable means and measures, including financial and technical assistance, in a manner calculated to foster and promote the general welfare, to create and maintain conditions under which man and nature can exist in productive harmony, and fulfill the social, economic, and other requirements of present and future generations of Americans (6-24 at § 4331 (a)).

To implement that policy, the act directs that, to the fullest extent possible, all policies, regulations and laws shall be interpreted and administered in accord with the purposes of the act. Also required is the now famous NEPA environmental impact statement. The statement must survey the following five items:

- the environmental impact of the proposed action
- any adverse environmental effects which cannot be avoided should the proposal be implemented
- alternatives to the proposed action
- the relationship between local short-term uses of man's environment, and the maintenance and enhancement of long-term productivity
- any irreversible and irretrievable commitments of resources which would be involved in the proposed action should it be implemented. (6-25 at §4332 (2) (c)).

The significance of NEPA can be seen by a comparison of two cases - one pre-NEPA and the other post-NEPA - both involving the Atomic Energy Commission. In 1969 (prior to NEPA) a United States Appeals Court found that the AEC need not consider the thermal pollution impact of a proposed nuclear power plant (6-27). Only two years later, after the enactment of NEPA, another court found that the AEC's regulations were inadequate because they failed to fully consider environmental factors, including thermal pollution (6-28). It must be emphasized again that NEPA requires all agencies of the Federal government (including courts and agencies involved in the energy system) to interpret and administer all policies, regulations and law in accord with the environmental purposes of the act. The environmental attractiveness of hydrogen as a fuel and/or energy carrier would fit in well with the NEPA requirement. Production methods, however, may present significant problems.

Supplementing NEPA are various Federal acts designed to protect specific areas of the environment. The Clear Air Act of 1970 (6-29) has had recent emphasis. In Sierra Club v. Ruckelshaus (6-30) it was held that the phrase "to protect and enhance the quality of the nation's air resources" means that there can be no [not even the slightest down turn to standardized clean air] degradation of pre-existing clean air. The Federal Water Pollution Control Act Amendments of 1972 (6-31) establish a complicated and comprehensive Federal permit system under Federal standards to insure clean water. For example, the Act requires that by no later than July 1, 1977, permit holders must use the "best practicable [waste] control technology currently available". Its breadth of coverage ranges from domestic water sources to the high seas. The Rivers and Harbors Act of 1899 is the most famous of the Federal criminal environmental protection acts (6-32). Even though the Act was quite strict, the Supreme Court

in a recent case - United States v. Pennsylvania Industrial Chemical Corporation - (6-33) added new bite. The Court noted that the Act made it unlawful to discharge or deposit, into navigable waters, any refuse matter of any kind or description whatever, except as permitted by the Secretary of the Army. The Secretary of the Army had not established a permit system. The defendant-polluter argued that it could not, therefore, be guilty of violating the Act. It also argued that it had been affirmatively misled by the Army Corps of Engineers long standing interpretation of the Act as applying only to deposits hindering navigation and not to industrial pollution. The Court held that the government could prosecute even in the absence of promulgation of a formal regulatory permit system, although it did hold that the accused could present evidence to establish the defense of being deliberately misled.

6.3.3.3 STATE AND LOCAL

Every state and locality has power to protect the environment. Because of the great diversity, no attempt will be made to catalog or organize the laws; rather, some highlights will be mentioned. Perhaps the most significant recent development has been the inclusion of environmental protection in state constitutions. Florida, Illinois, Michigan, New York, Pennsylvania, Rhode Island and Virginia all have recently adopted constitutional provisions concerning the environment. Some of these enact constitutionally-based provisions giving the citizen a right to a clean environment (6-34).

The basis for state and local regulation of the environment is the traditional idea of police power possessed by state and local governing bodies. The conventional rule has been that these powers are not to be superseded by a Federal act unless there was a clear Congressional intent. As concluded below, however, the trend seems to be that Congress (with the assistance of the courts) will find, in ever increasing areas of environmental control, a need for a federalized environmental law.

6.3.3.4 PRIVATE

We turn now to the private environmental law remedies that can be asserted by groups and individuals. These include:

- constitutional theories
- public trust doctrine
- statutory remedies
- common law tort remedies

The most frequently asserted constitutional theory is the Ninth Amendment idea that

there is a zone of reserved rights which the government must guard and protect from intrusion. Often cited for this proposition is Griswold v. Connecticut (6-35). Development of the constitutional right to a clean environment at the Federal level seems to have little potential, although, as noted above, a state right may exist.

An offshoot of the constitutional right argument is the Public Trust Doctrine. This doctrine has been extensively surveyed by Professor Joseph L. Sax of the University of Michigan Law School (6-36). The doctrine specifies that there are certain common properties (river beds, sea-shore, lands) held in the public trust by the government for the use of the general public. When such common properties are reallocated to private uses and where there is not substantial evidence that the private use has a considerable degree of public benefit, the government has defaulted on its trust responsibility. While the Trust Doctrine has been applied in a rather limited number of areas, it may play an increasing role in the private protection of the environment as increased energy needs threaten the naturalness of the public domain.

The third area of private environmental law is statutory remedies. The trend now seems to be for the states to provide an increasing amount of private statutory remedies while the Federal government is limiting the availability of private remedies. For example, the Supreme Court in 1972, in the notable case of Sierra Club v. Morton (6-37), found that the Sierra Club lacked standing to sue because it had failed to allege that it or its members were adversely affected by the proposed action of granting a permit for recreational development of Mineral King Valley. The Supreme Court went on to say that the plaintiff, a private party, must show that he himself will suffer injury - economic or otherwise. While this case is on the general topic of 'standing', it severely restricts the ability of a private citizen to assert any sort of statutory remedy for environmental degradation. Mr. Justice Douglas, in dissent, asserted the interesting theory that inanimate objects (such as forests, oceans, rivers), should have legal rights (6-38). Douglas noted that contemporary public concern for protecting nature should lead to conferral of standing upon environmental objects to sue for their own preservation. It is noteworthy that Mr. Justice Douglas was a minority of one.

The fourth area of private remedies for environmental deprivation lies in the venerable theories of the common law. A part of the common law is tort law or 'he hit me' law. Trespass is an ancient action for damages or an injunction where there

is a deliberate intrusion on land. Another tort theory is nuisance. Nuisance is perhaps the oldest and most used of the common law remedies to control pollution. It generally requires an unreasonable interference with the use and enjoyment of the land. What is unreasonable is determined by a balancing of the benefits to the community at large and the defendant in particular against the inconvenience costs to the plaintiff. Usually the nuisance theory has been used to adjust the intangible invasions of land such as noise, dust, odor and the like. The next theory is negligence. In negligence the landowner must show that the polluter has failed to exercise reasonable care in preventing pollution of plaintiff's property. The last theory is that of strict liability for ultra-hazardous activities, defined as those activities which can be characterized as abnormally dangerous such as blasting.

6.3.3.5 CONCLUSION

Preemption of state authority for environmental protection appears to be increasing. The trend is indicated by two recent cases. In the first case, Northern States Power Company v. Minnesota (6-8), a Federal Court held, in an important first impression case, that the Atomic Energy Commission regulations had preempted the State of Minnesota from any regulation of the levels of radioactive effluents discharged from nuclear generation plants. Also noteworthy is City of Burbank v. Lockheed Air Terminal (6-39). The Supreme Court noted that Congress in enacting the Noise Control Act of 1972 and the 1972 Amendments to the Federal Aviation Act involved the Environmental Protection Agency in a comprehensive scheme of Federal control of the aircraft noise problem. The Court concluded that Congress had preempted state and local control over aircraft noise. This conclusion was reached despite the fact that there was no express provision of preemption in any of the Acts. It was the pervasive nature of the scheme of Federal regulation of aircraft noise that led the Court to find preemption. It may be forecast that these two cases are portents of the future wherein there will be increasing Federal preemption in areas previously thought to be exclusively the state's domain for environmental protection.

6.3.4 INTERNATIONAL LAW

Since several of the suggested methods for the production of hydrogen would use large quantities of water and would produce substantial quantities of reject heat, it has been suggested that the plants be located offshore. Proposed offshore locations vary from the shoreline, to the territorial sea, to the contiguous zone, to the continental

shelf sea area, to the high seas. Each one of these siting locations itself, along with the production process by-products (primarily salts and reject heat) and the use of large quantities of water, raise serious international law questions.

The threshold question is, who owns the seas? The traditional answer to this question has been, no one. Under the basic principle of the freedom of the seas, the seas, the water itself, marine life, and the minerals (in and under) belong to no one; or, in other words, they were treated as res nullius. Since the seas and its resources belong to no one, it follows that any one could use them in any manner, for any purpose. There are, however

growing signs of an inclination to treat the oceans and other resources shared in common as res communis, belonging to the community rather than res nullius (6-40).

This shift in international law was created by a two-fold desire: to exploit the resources of the seas, and to control the pollution of the seas and its resources so that they may continue to be available for exploitation. An answer to the legal implications of the res communis ideal is not now available. A world conference on the Law of the Seas is to be held in Santiago, Chile in April, 1974. The purpose of the Conference is to answer some of the questions presented by technological developments in methods to exploit the resources in and under the seas. The major aim of the Conference is to write a treaty dealing with the development, as well as the sharing, of the sea's resources. To be considered are mineral rights, fishing rights, freedom of navigation, pollution control, and more than twenty other major issues (6-23 at p. 1378). Pending the results of the Santiago Conference, we may make some general baseline statements of existing international law which may have some impact on proposals to locate hydrogen generation plants offshore.

The old pristine idea of res nullius no longer exists. It is now settled that the seas (and its resources) are divided up into several bands. Working outward from the shoreline we come first to a band known as the territorial sea, then to a band known as the contiguous zone, then to a band known as the continental shelf, and finally, to the high seas. It is clear that the territorial sea is part of the territory of the coastal state, that is the coastal state owns it. Since ownership is a valuable right (the coastal state owns the natural resources and can keep others out), coastal states want as much territorial sea as possible. There is no general agreement in international

law as to the width of the territorial sea. While the United States claims that its territorial sea is an internationally acceptable three miles, other countries make claims of a width of a territorial sea anywhere from 6 to 12 to 25 and indeed up to 200 miles (6-41). Nevertheless, should the hydrogen generation facility be located in the United States' territorial sea, it would be subject to all the domestic laws of the United States as well as some minimal international law requirements such as non-obstruction of navigation as well as developing international standards on pollution (6-41, 6-42, 6-43).

The next band of the seas is that area known as the contiguous zone. It is 12 miles in width and includes within it the territorial sea, if that is less than 12 miles. The contiguous zone is not owned by a coastal state but it can exercise considerable authority in it as needed to prevent the infringement of its customs, fiscal, immigration, or sanitary regulations within its territory or territorial sea. Thus, should the hydrogen generation plant be located in the contiguous zone, it would be subject to all domestic American laws concerning pollution, as well as international rules against interference with navigation and developing international pollution controls (6-44).

The next band is known as the continental shelf (6-45). It is defined generally as the seabed extending from the shoreline to a depth of 100 fathoms. The Continental Shelf Convention reserves to the coastal state the exclusive right to explore and exploit the natural resources on the seabed and in the subsoil of the continental shelf. In so doing, however, the coastal state must not unjustifiably interfere with navigation, fishing or the conservation of living resources of the sea. All appropriate measures must be taken to protect the living resources of the sea in areas (known as safety zones) surrounding installations or devices on the continental shelf. It seems fairly clear, then, that a hydrogen production facility could, consistent with international law, be sited on the American continental shelf (assuming its configuration to be analogous to an offshore oil drilling rig). International law constraints would severely restrict the size and the plant's ability to 'overboard pollution.

Finally, we come then to the last band of the seas - the high seas. The international law of the high seas is codified in the Convention on the High Seas (6-46). Its basic principle is the freedom of the high seas; the high seas are open to all nations, and no one may validly subject any part of it to ownership. While the Convention makes no attempt to provide an exhaustive list of the various permutations

of the basic principle, it, most significantly, cautions in Article 2 that such freedoms are to be "exercised by all states with reasonable regard to the interests of the other states in the exercise of the freedom of the high seas" (6-46 at Art. 2). Article 25, in part, of the convention also specifies that

All states shall co-operate with the competent international organizations in taking measures for the prevention of pollution of the seas or air space above, resulting from any activities with radioactive materials or other harmful agents (emphasis supplied) (6-46).

The question then becomes: (assuming that a hydrogen production facility were to be sited on the high seas) could it be argued, under Articles 2 and 25, that the quantities of reject heat and salts resulting from the production process would be an unreasonable use of the high seas and/or a pollution of the seas by 'other harmful agents'? Such may well be the case (6-47). This interpretation is in accord with the United Nation's 1970 Declaration of Principles Governing the Seabed and Ocean Floor:

States shall take appropriate measures for and shall co-operate in the adoption and implementation of international rules, standards and procedures for, inter alia:

- (a) The prevention of pollution and contamination, and other hazards to the marine environment, including the coastline, and of interference with the ecological balance of the marine environment;
- (b) The protection and conservation of natural resources of the area and prevention of damage to the flora and fauna of the marine environment (6-48).

Also supportive of that interpretation is Article 5 of the Convention on the Continental Shelf which, while applicable only to the continental shelf, provides in pertinent part:

The coastal state is obligated to undertake, in the safety zones [around installations or devices on the continental shelf], all appropriate measures for the protection of the living resources of the sea from harmful agents (6-45).

To be sure, the ultimate shape of international law must await the results of the 1974 world conference on the Law of the Seas, but one final note must be made: that Conference may write into the new law of the seas a wholly new concept -

that emerging concept may be labeled Shared Development. Significantly, the conference was called to write a treaty for the development and sharing of the ocean's resources. Similarly, the basic premise of the report to the United Nation's 1972 Conference on the Human Environment was that a certain level of development not yet reached in the developing countries is a prerequisite for a decent environment and all developed nations must help the have-nots (6-49). Thus, if a hydrogen production facility were to be sited on the high seas, it may well run into severe objection on environmental grounds (mentioned above) and/or strong demands from the developing countries of the world for a share of the energy produced (6-50, 6-51).

6.4 ENVIRONMENTAL IMPLICATIONS

Hydrogen is produced primarily from an abundant and noncontaminating raw material - water. When combusted, it again becomes water and rejoins the water cycle; in a sense, it is Mother Nature who returns the empties for re-use at no charge and in short time periods. However, as a synthetic fuel, we must consider whether hydrogen can be produced by a base power source which is environmentally sound. Further, any fuel must be transported and stored, and we must examine possible adverse effects of this sector. Chapters of this report dealing with production and with transportation-storage of hydrogen include extensive evaluations of those particular environmental aspects.

Simply put, there are two possible environmental contaminants which result from hydrogen combustion - NO_x and water. We do not normally consider water to be a contaminant, but there are some conditions under which hydrogen combustion might produce sufficient water to be a problem. For example, tightly insulated homes using ventless hydrogen space heaters might require dehumidification. It is possible that areas of high-use, such as a hydrogen-fueled city, might develop a water island effect similar to the heat island which develops around cities due to reject heat. Although this problem needs study, we expect a very minor impact will be found. Table 6-2 shows the relative amounts of water produced per Btu by three energy sources.

TABLE 6-2
WATER PRODUCTION FOR VARIOUS ENERGY SOURCES

Fuel	lbs water/Btu
Gasoline (C_8H_{18})	74×10^{-6}
Methane (CH_4)	105×10^{-6}
Hydrogen	174×10^{-6}

Although some added water product will be found, the difference is certainly not great. When hydrogen is burned with pure oxygen, water would be the only combustion product. If burned with air at high temperatures (above approximately 1750°K) atmospheric nitrogen would become involved and some amount of NO_x would be produced. Such high temperatures would be rare in residential use and found only in specialized commercial uses, where controls should be possible. These hydrogen burn characteristics compare favorably with the usual hydrocarbon combustion which produces not only water, but a witch's brew of unburned hydrocarbons; NO_x, CO, CO₂, SO₂ and much more.

One fact is inescapable: Americans cannot have energy and zero environmental impact. Heat engines must necessarily produce reject heat; transportation of energy requires vehicles and highways, pipelines, transmission lines or other structures which may produce visual pollution if nothing else. The production of base power in large quantities involves, at the very least, land use problems. Hydrogen and electricity may be compared in that both may be produced from a variety of base power sources. We may thus design a system which minimizes environmental damage at the source by making a flexible choice of the environmentally optimal generation method. Hydrogen has an advantage over electricity in the areas of transportation and storage. Overhead electrical transmission lines range from unsightly to ugly, a fact which is rapidly driving electrical transmission underground. But underground electrical transmission is currently an order of magnitude more expensive than pipeline hydrogen transmission of equivalent energy. Storage of electricity in large amounts is not yet possible, except through the use of indirect methods such as the expensive and environmentally undesirable technique of pumped storage. Storage of hydrogen in large quantities is possible, either underground with very minimal environmental impact or above ground, but with much less land use impact.

Electricity and hydrogen are both clean-burning in end use. It is primarily between the generating plant and the end use that hydrogen has environmental and cost advantages. Electric power transmission is conventionally done by means of overhead lines, but environmental objections are driving the cost of overhead transmission rapidly upwards and may soon make it virtually prohibitive. However, long-distance underground electrical transmission is more than ten times as expensive as overhead transmission. Hydrogen, by contrast, can be transmitted any necessary distance without significant power loss by means of underground pipe-

line, at a cost which would probably be about 10 percent of the cost for underground electrical transmission. Since hydrogen could be used as a natural gas substitute in most applications, and could be used in local fuel cell or turbine substations to regenerate electricity, hydrogen pipelines may replace electrical transmission lines as the nation's long-distance energy carrier.

As noted above, both electricity and hydrogen are limited for mobile power use, as in automobiles, primarily because of storage problems. The weight, bulk, or expense of storage batteries for electricity plus the limited range attainable has placed definite practical limitations on the much-discussed electric automobile, despite its otherwise favorable environmental character. Hydrogen suffers from similar storage limitations; the low density of hydrogen dictates that an automobile with any range would need to carry a very bulky tank which may be difficult to handle safely. A cylindrical tank 20 by 60 inches would hold about 35 gallons of liquid hydrogen, equivalent to approximately 12 gallons of gasoline in energy content, and would be much more awkward to handle than today's conventional "fill'er up" at the corner station. Primarily for this reason, we do not consider the use of hydrogen in automobiles as a likely alternative in the near future. However, the concomitant effects of environmental controls and gasoline high prices or scarcity may override these constraints. If the storage limitation can be resolved by a modified automobile design or by acceptance of limited ranges (as in the "urban car" intended for short-range travel only), and if the physical and safety limitations of handling liquid hydrogen for this purpose can be circumvented, environmentalists may rejoice in almost ideal auto exhaust content. At the same time, the auto-driving public could still use the private, flexible transport to which they have become so practically and emotionally attached. Politically and socially, this is a solution devoutly to be desired.

In short then, hydrogen per se is environmentally an almost ideal fuel. It is significantly cleaner than hydrocarbon fuels, and its only combustion by-products should be easily controlled. Hydrogen transmission by underground pipeline offers aesthetic advantages over conventional electrical transmission. Hydrogen's environmental impact is likely to be highly positive, allowing cleaner cities and factories. The adverse impact, if any, will be connected chiefly with the method by which hydrogen is originally produced.

6.5 SOCIO-ECONOMIC IMPLICATIONS

6.5.1 INTRODUCTION

United States material wealth and national power have rested upon a relative abundance of natural resources, an industrious and capable population, an abundance of energy and no doubt an occasional bit of luck. Darmstadter (6-52) has presented data establishing a close relationship (correlation coefficient of +0.87) between high energy consumption rates and high Gross National Product per capita for a large sample of nations. Cook (6-53) and others have noted the same basic relationship. American society is an affluent (even affluent) society in which the availability of massive quantities of energy at low prices has been a major supporting element. In the current energy shortage we face important questions: Can enough energy at low enough prices be assured that we can maintain our way of life indefinitely? Failing that, can other ways of life be found which are less energy-intensive but still satisfying? Can other factors substitute for high-level energy consumption (better information, different social values emphasizing areas of low energy use, etc)? Do we have the intellectual tools to really understand and analyze such questions? This section explores these vital questions.

6.5.2 SOCIAL COSTS AND VALUES

One question has an answer which is much more clear than it is satisfying: at this time we do not really understand the basic questions of social costs and values which are so critical to the energy field. Social factors are in part responsible in creating the current energy shortage. Legislative and other restrictions on strip mining, offshore oil exploration, nuclear plant siting and safety, automobile emissions standards and many others have all played a part. These actions have helped to control a growing pollution problem and preserve environmental purity levels, but is it worthwhile to do these things, in view of the other costs? We do not know. Caldwell (6-54) concludes that an ecologically right position may be politically wrong; but conversely, a political right may be an ecological wrong. Lueck (6-55) has pointed out that we have not yet clearly defined the questions. Is social cost the difference between Plant A with 100 percent effective pollution controls and Plant B with zero pollution controls? Or is social cost the difference between the cost of pollution controls in Plant A and social benefits obtained by those controls? If the money cost is higher than the social benefit, should pollution be permitted? He concludes that "there is no way in the present market on purely economic grounds to compare the cost of pollution control measures with

the social costs which are incurred if the measures are not taken".

There seems to be little disagreement with this view (6-56, 6-57). Coddington (6-58) has said, "it may even be the case that the greatest service economists can render posterity is to remain silent" on the topic of social costs. Can values be placed on such things as a factory's use of the atmosphere as a heat sink, a city's dumping of sewage into a lake, an individual's careless dumping of paper cups by the highway? These external costs or social costs are costs which are paid by society as a whole rather than by the individual/city/company which litters, dumps or smokes; we are not yet able to properly assign costs. Sachs (6-57) has warned that economists as a profession usually make

two heroic and often unspoken assumptions... The first postulates a two stage reductionism: all things can be reduced to their economic dimension and the economic dimension yields itself to a quantitative treatment; a market or quasi-market value can always be found or estimated. The second takes an associationist approach to build macro-economics from microeconomic considerations.

Sachs goes on then to suggest that political economy may be a more fruitful approach. Ridker (6-59) essentially agrees, finding that the values in political economics are not really quantifiable but are crudely measureable by one device - the legislator.

Since elected representatives, more than any other segment of our society, are attuned to the attitudes that form psychic costs, and since psychic costs are likely to be a large portion of total costs, their assessments may not be too far from the mark. In any event... there may be no other solution for some time to come.

Davies (6-60) has made somewhat the same point. Recognizing these difficulties, it is nevertheless prudent to review quickly environmental economics.

Any economic activity may be analyzed from a number of points of view. One new viewpoint may be labeled environmental economics. The comments immediately following are based on two recent publications (6-61, 6-62) and our own thoughts on the subject.

Perhaps the most familiar environmental economics approach is the cost method. It posits that economic activity involves costs. Costs are then divided into two types; internal and external. Internalized costs include such familiar items as capital, labor, materials, overhead,

depreciation, etc; in short, those things that are real costs in an economic activity. On the other hand, external costs (also known as social costs) include such things as pollution, unsightliness, noise, odors and the like. These costs are not born by the economic activity but are the price that society in general must pay. While this may seem unfair at first blush, it can readily be seen that it would be most difficult and indeed almost impossible to come up with an index of, say, how much a bad odor costs. Economists, until most recently, have, therefore, tended to ignore external costs.

Another environmental economics analysis is the 'goods' method. It states that any economic activity involves the use of goods. Goods are of three types - economic goods, public goods and free goods. Economic goods include such familiar items as raw materials, equipment and the like. Air and water are the prototypical free goods because they exist in such super-abundance that they are free to everyone. Thus, no one pays for the air that he breathes or that his car uses or the cooling water that a factory uses. A public good may be described as a formerly free good but which has become subject to competition for its use beyond its free availability and thus comes under public control usually under a licensing system. A good example is the wave bands on the radio spectrum (which were formally a free good) now regulated and allocated by a comprehensive Federal government licensing scheme.

Economic goods have an economic value and are hence controlled by the market mechanism; they can be bought and sold for a price. Public goods and free goods, on the other hand, are outside the market place and do not have an economic value; they do not have a price and cannot be bought or sold. While it is highly unlikely that public or free goods will ever become economic goods (that is to say they will never be bought and sold in the market place) there is a changeover point at which a free good may become a public good. That point is reached when competition for its use sets in, because it is so heavily used/or polluted, that it loses its ability of self renewal. In a word, the changeover point is reached when the free good becomes scarce. It should be noted, however, that the change is not a total break of free to the public but is gradual, resulting in less free and more public.

It is a familiar fact that in many places in the United States and the world there is intense localized pollution of the air and/or the water - Los Angeles, Birmingham, Tokyo, Lake Erie, the Rhine and Vienna's Canals. An environmental

economics analysis of pollution on that level can lead us to say, on increasing levels of sophistication, the following:

- simplistically, those localities have run out of clean air and/or water, or
- a little better, the self-renewability of the air and/or water in those localities has been exceeded, or
- better, to control the pollution in those localities the external (social) costs of the dirty air and/or dirty water should be internalized, or
- even better, to control the pollution in those localities the free good of air and/or water must become at least a public good and perhaps ultimately an economic good.

From this analysis it can now be seen that antipollution laws, from an environmental economics point of view, are in reality, attempts to internalize pollution costs or to change free goods into public goods. While it may never be possible to place an economic value on social costs or to charge for air or water, we anticipate that the concern for the environment will not diminish. The push for environmental quality will result in increased costs as more and more external (social) costs are forced to be internalized; and stricter standards for air and water purity decrease their free nature and increase their public character. The impact of this on a hydrogen economy is obvious: hydrogen energy will simply be more costly. An appreciation of environmental economics was ever present throughout the study and is evident, we believe, in this report.

Weinberg's (6-63) famous question, "can technology replace social engineering", led him to answer in the negative. He found that social situations become problems whenever enough people decide that they are, and that social problems are solved whenever enough people agree that they are. As he put it, "how do we know when our cities are renewed, or our air clean enough, or our transportation convenient enough?" The answer today is not available from technicians or economists but rather from Gallup polls or legislative actions. Technology, not merely a problem-maker, can help resolve social dilemmas by expanding the range of available choices. That this has been vaguely recognized is shown by Congress' 1972 establishment of an Office of Technology Assessment. It is too early to expect immediate and definite results from that Office or any other attempts (6-64).

6.5.3 ENERGY AND THE SOCIAL FUTURE

American society - indeed, the society of all major industrial countries - is ultimately connected to energy. The political, social and economic power of the oil companies is almost a cliché; such symbols as the depletion allowance are widely understood - or misunderstood - as important to economics, politics and society. Symbol and fact - "Reddy Kilowatt", strip mining, the Friends of the Earth, the Alaska pipelines, the AEC - are important forces in our society. Each represents a point of view; a value position.

Neither the positions, nor the implications of the positions are well understood. There has been a "counter-culture" exhortation to resolve the energy crisis by decreasing rather than increasing the rate of energy consumption. We normally expect such suggestions to emanate from supporters of social improvement programs. But they have been criticized by advocates of energy expansionism - usually thought of as fat cats and opponents of social change - on the grounds that restricted energy use will result in freezing the poor into eternal poverty by denying them energy and hampering anti-poverty development programs. Environmentalists incur the scorn of progress advocates who argue that restrictions on energy production are counter-productive because cleaning up our national mess will require more, not less energy.

A different energy system, particularly if it involves restricting energy, will have a massive impact upon our society. As one example, if energy use is restricted but anti-poverty programs are continued, there must be a redistribution of wealth by taking from the rich to give to the poor a greater share of a relatively static supply. The steady-state (6-65, 6-66, 6-67) economy may obtain an equilibrium no-growth point, but social dynamics continue to require readjustments within the overall equilibrium. This would present American social and political institutions with unprecedented value and practical questions, and would clash with such deeply-held social myths as quality, development, progress, keeping up with the Joneses, and what might be called the American way of life. Even a shift from one form of energy to another (as from coal-electric to nuclear-hydrogen) will affect the relative positions of social vested interests, the economic viability of whole cities, states and regions and certainly occupations and dwelling patterns. Forecasting those changes is difficult, and with present knowledge probably impossible if a high degree of accuracy is required. Battelle Memorial Institute has found that energy forecasts made during the 1960's all lacked adequate consideration of environmental factors and that few dealt with possible con-

straints on access to foreign supplies of energy (6-68). The impact on both economics and petroleum requirements by the NEPA automobile emissions controls has been quite large and was unforeseen. Safety and environmental requirements have combined to constrain development of nuclear power plants to a pace much slower than expected.

Due to complexities in society, both the dire warnings and the optimistic projections undoubtedly need corrections. Morris (6-69) has studied several of the arguments that high energy use will be required to clean up the environment and that a net increase in energy needs is indicated. He concluded that in some cases this is correct. But he also found that added demand is probably one percent or less and that the clean up cost, therefore, is not an important factor. For example, controls on automobiles may result in smaller, more efficient engines and thus in a net decrease in energy use (although current experience is in the direction of increased petroleum use). Recycling may reduce energy demand. Recycling aluminum, for example, requires only about 10 percent or less of the energy needed for original smelting. A recent study of the beverage industry (6-70) finds that use of returnable, refillable bottles would save some 70 to 80 percent of the total system energy required for one-way bottling, and would reduce waste disposal needs by a factor of six to ten, depending on the number of refills per bottle before final discard. Since our society has had experience in both recycling (as in World War II) and in using throwaways, and can obviously do either, the choice becomes a social one: which is valued more highly, energy savings, reduced waste disposal requirements and thus lower taxes, or greater consumer convenience and better profit margins for manufacturers and retailers.

6.5.4 ECONOMIC COSTS

Reference is made elsewhere in this report to the threat of shortage in natural resources. Petroleum and many minerals are becoming scarce, thus forcing us to turn to lower quality or higher cost; or to accept higher social costs in greater environmental damage or increased reliance on external supplies. But there is another shortage--very real and as yet largely unappreciated by the public--of economic resources.

In order to provide the energy requirements so freely forecast for the next fifty years, society must generate enormous amounts of capital investment. It will be necessary to develop new supplies through improved techniques, research and development. It will be necessary to construct refineries, tankers, pipelines, railroads,

superports, nuclear fuel enrichment and fabrication, facilities, etc. It will also be necessary to pay interest on borrowed capital, to provide environmental protection facilities, and to develop marketing/distribution systems. The price tag for these far-flung investments will be enormous. Chase Manhattan Bank estimates that the non-Communist world will need to find one trillion dollars in capital for the petroleum industry alone in 1970-1985 (6-71). The National Petroleum Council (6-72) has estimated that the 1971-1985 capital cost of the United States' energy industry will reach \$450 to \$550 billion; Chase Manhattan estimates approximately \$400 billion, a figure some eight times the capital investment made in the 1955-1970 period (6-73). Hottel (6-74) and others have cited a need for oil and LNG tankers which varies from some 350 tankers of 250,000 tons each up to as many as 1000 tankers, all very large, by 1985. Capital cost estimates for these tankers and their associated superports vary widely; but \$40 billion should be a conservative estimate.

The scale of nuclear energy capital needs is likewise large, and has been getting larger rather than smaller. The fast breeder reactor demonstration plant at Oak Ridge which the AEC, the TVA and private industry have agreed to build by 1980 is estimated to cost \$640 million (6-75). This unit cost may be reduced for later installations, but the capital needs for widespread nuclear development will climb high into the billions.

If we accept the National Petroleum Council's estimate of approximately \$500 billion capital investment required by 1985 for development of the United States' energy system, it is clear that enormous amounts of social resources will be absorbed in this one area. It is not at all certain that the private market has this much capital available (6-73). It is very probable that the nation's energy industry will turn to the federal and perhaps the state governments for assistance - perhaps even as partners as in the case of the fast breeder reactor demonstration plant noted above. It is also within the realm of probability that government interests and private capital shortages may produce further development of government energy organizations on the TVA model. We do not see how the hydrogen economy can be more than a marginal aid in this situation; it may perhaps relieve some foreign exchange burdens. Since some conversion costs would be incurred in transition to hydrogen, there may be no net economic gain.

The probability of very large scale energy development under control of the Federal and/or state governments suggests that here is an opportunity for the introduction of large-scale, integrated

hydrogen systems. Predictions of growth in all areas of American life suggest that, since a great deal of added construction--even a number of new cities--will be needed, it will be possible to construct a planned, integrated model city based on hydrogen energy. This option should be considered by Federal energy policy groups. Future growth in Hawaii, for example, might combine a solar, wind, or geothermal power source with hydrogen production to reduce Hawaii's costly dependence on imported hydrocarbons. These possibilities are more fully explored in Chapter Seven, Implementation.

6.5.5 HYDROGEN AND SOCIETY

Hydrogen and electricity both require some base power source for their production. Each is flexible, and they are nicely complementary for some purposes (e.g., hydrogen as a storage form for electricity). A major social advantage of hydrogen over hydrocarbons is environmental in that it could be used in any quantity without creating waste management or pollution burdens. Aesthetically, pipeline hydrogen avoids the scenic clutter of overhead electric lines. Perhaps most importantly, hydrogen fuel can be substituted for many petroleum fuels. This relieves the social tension inherent in managing a resource which is growing scarcer, releases remaining petroleum for those chemical uses in which it is vital, and allows greater national self-sufficiency in energy supplies.

Rapidly declining natural gas reserves will mean that soon natural gas users must either:

- stop their activity,
- pay much higher prices and accept risks of supply interruption due to dependence on foreign sources, or
- switch to synthetic gas

In some cases, use of electricity under restraints of technical and environmental nature may be possible. Hydrogen, a synthetic fuel, could be produced and transmitted by pipelines already in existence (with slight modifications or additions) which might otherwise lose their function. Saving this enormous capital and energy investment for continued use is a social benefit of great value.

Emissions controls and petroleum scarcity/cost are rapidly developing towards a point where the private, personal automobile may become a luxury for the few. The enormous social overhead invested in the automobile and its associated appurtenances (highways, repair facilities, etc.) should be conserved if possible. Further, since so many social, life style, and economic patterns are keyed to the private automobile--over 80 percent of the United States work

force commutes to work by automobile-- there would be major social dislocations inherent in significant restrictions on automobile use.

A wholesale switch to a radically different energy form would require a revolution in the auto industry (6-76); this alone suggests that such variations as the electric automobile are socially expensive. Electric cars have energy storage restrictions, (Section 5.3.3) and are energy-expensive. A synthetic fuel similar to present hydrocarbon fuel, such as hydrogen-produced ammonia, could be more readily assimilated and at lower social costs.

It is not clear that such a minor transition--from gasoline to the functionally similar hydrogen--would be overly expensive when compared to the costs of continued hydrocarbon use. It would be necessary to make major modifications in storage and handling but perhaps minimal changes elsewhere. Fortune (6-77) estimates that the difference in on-the-car emission controls between 1975 and 1976 alone will amount to \$3 billion. David (6-78) says that between 1975 and 1985 the environmental-protection costs for automobiles will approximate \$100 billion. Such costs do not include the social costs of using irreplaceable petroleum fuels, balance of payments deficits, and United States energy dependence on external supplies. It may be that hydrogen is thus worthwhile as a replacement fuel.

6.5.6 CONCLUSION

We know rather little about the role of energy as a social force, but we do know that the role is important. It is probably much more important than we bothered to notice during times when energy supplies and reserves were abundant. We know very little about how to calculate social costs. We can, however, state that to the degree that a new fuel is compatible with present uses of the old fuel, and to the degree that replacement can be carried out at low cost in terms of dollars and life style changes, it will be quite socially desirable. Hydrogen offers potential improvements in the environment, and protection against external influences. It is now time to develop careful studies which can clarify and perhaps even answer some of the questions raised in this report.

6.6 POLITICAL IMPLICATIONS

There are essentially two ways to analyze the political effects of hydrogen as an energy medium: that of considering the political role of energy in general, or that of attempting to isolate particular

effects of hydrogen as a unique form of fuel. It seems appropriate to consider, first, certain aspects of the politics of energy and then to ascertain any particular impact of hydrogen as fuel.

6.6.1 POLITICS AND ENERGY

American use of energy has meshed with several strong values in the American social, political, and economic system to produce a peculiar set of inputs and outputs. The society has made several demands related to energy provision and utilization: that progress must exist in an observable fashion, generally in the form of an ever-rising standard of living measured chiefly in material goods; that the premise of a consumer-controlled, market economy based upon a system of private property and private competitive enterprise must be maintained as a value and as a symbol; and that the public image of the United States as a great nation be preserved. All of these requirements produce an implicit energy policy: the supply of energy must be adequate at all times, which means that it must constantly grow larger; the price of energy must be kept at a level which does not impede its use to support progress; and energy production should be carried out primarily by private enterprise, although government regulation is allowed as a (regrettable) necessity due to the interstate character of energy supply, natural monopolies, and other factors.

In support of these demands, the United States historically has possessed an abundance of readily-available raw materials, a high-grade technology capable of performing the necessary engineering, and an abundance of empty space in which things could be thrown away after use. The economic system has generally performed quite effectively in providing the rising living standards, the growth capital, and the cheap energy required. The image of the United States as the number one nation has been buttressed by the above factors plus the enormous military power and political-economic influence which our energy-rich society made possible. However, service to the energy demands and values associated with them has now brought us to a confrontation with issues not previously raised in this country--or, in some senses, in any other country. Our use of an energy-rich economic mix and our virtually unquestioning identification of growth with progress has resulted in an enormous economic expansion, an energy shortage and the emergence of environmental protection concerns.

The United States adopted a set of petroleum policies which were nominally intended to encourage exploration for and development of domestic petroleum resources. This was intended to create sufficient domestic petroleum production so that, in

the event of war, we would not be dependent upon external sources for vital fuel supplies. Extensive development of domestic petroleum fields plus import quotas on foreign oil, however, resulted in what someone has called a "drain America first" policy. But this also resulted in a growing dependence upon Middle East oil. It is one of the costs society now bears in return for what was considered a benefit - the operation of an energy-intensive system largely dependent upon the activities of private, profit-oriented businesses to whom low costs and high profits are not only desirable but necessary. A governmental energy supply agency might have followed a policy of drain the Middle East first and restricted domestic supplies. They are not presented here as good versus bad choices, but simply as political choices of the type any society makes.

In similar fashion, America has followed policies which subsidized energy costs in order to encourage economic expansion. One form of subsidy was failure to count environmental costs as part of the cost of production and consumption. Air, water, and other environmental factors were viewed as free goods; an infinite stock. There is no doubt but that these policies have been effective in attaining the overall goal of progress but also helped produce the current energy and environmental problems.

The United States now has a rapid and increasing rate of consumption of non-renewable domestic petroleum and natural gas. Chapter Five, dealing with energy demand, illustrates the enormous magnitude of future demand and raises questions whether such growth, both in rate and absolute magnitude, is either possible or desirable. It is common, but extremely misleading, to evaluate resource reserves in terms of how many years' supply is represented at current rates of consumption because those rates will increase drastically unless action is taken to stop the growth of consumption. If environmental disruption has created such concern at current rates of consumption, surely that concern will grow as consumption grows. If current rates of strip mining for coal arouse intense counter-pressures it seems certain that the vastly increased mining required for extensive coal gasification--a solution offered by many studies--will generate even more opposition (6-79). Such objections are usually answered by assertions that:

- When energy becomes really scarce and expensive, so that high living standards are threatened, environmental objections will fade before pressure to produce the needed energy;

- To restrain our ever-increasing

growth in any significant way would be to produce stagnation, and even disaster.

Both of these replies are traditional in terms of American political, social and economic values. To suggest the possibility of a steady state economy (6-65) is to question the validity of one of the most enduring of American myths - progress. It may well be that there is no area of research more important to the American future than studies in the development of a steady state economy. Such an economy would not solve all problems and would indeed create many new ones. The standard reply to allegations of improper distribution of social wealth is that one can always better himself by hard work (implicitly assuming a constantly expanding economic pie). The problem of distribution is thus resolved by increased production. In a steady-state economy, a fair (given other American values, fair means approximately equal) distribution of worldly goods would necessarily require redistribution, a far more painful process. The political impact of such an economic system would be enormous, and this study can do no more than call attention to it.

We neither assert that the Club of Rome's Limits to Growth predictions (6-80) are accurate or inevitable nor forecast the necessary entropic collapse of the world's economy. We do assert that there are many reasons to believe that the basic premises of that study may be correct. There is at least as much reason to accept its warnings as there is to accept the more conventional technological optimist belief that, in ways not yet foreseen, the answers to looming problems will be discovered.

6.6.2 THE NEAR FUTURE (1975-1985)

In 1975-1985, energy is certain to become a major preoccupation in national politics. The level and scope of energy politics may be noted in such indicators as the June 29, 1973, Presidential statement on energy. Mr. Nixon announced a flurry of energy-related actions of significant political impact:

- Establishment of an Energy Policy Office to advise the President, with a list of responsibilities suggestive of a potentially wide range of powers;
- A request to Congress to establish a new Cabinet-level Department of Energy and Natural Resources and a new independent Energy Research and Development Administration;
- A reorganization and reassignment of the Atomic Energy Commission's powers and responsibilities;
- Increased funding for energy-related

research.

Creation of a cabinet department inevitably involves considerable political turmoil. Especially so in this case as various growth programs will be taken away from existing agencies and assigned to the new creation. Reorganization of the AEC and reassignment of its licensing powers to another agency will involve a great deal of backstage maneuvering as the opportunity arises to strengthen or weaken those powers during the transfer. This struggle is certain to attract the attention of the utility companies and the environmentalists.

Such recommendations are both practical and symbolic recognition that a need exists. Seidman (6-81, 6-82) has noted that certain barriers to technical innovations arise from a segmented bureaucracy in which

the discrete segments of our society perceive innovations in other segments as threatening...it is often difficult to gain widespread support for the allocation of resources to support innovation.

Grouping of energy-related agencies under one head may help resolve some of the interagency confusion and dispersion of effort which otherwise impede action. The recommended Department of Energy and Natural Resources would include, for example, a single Water Resources Administration with responsibility for the integration and coordination of national water resources policy and planning (6-83). Such a new agglomeration of authority may allow more rapid and comprehensive resolution of continuing controversies, such as those surrounding the construction of superports for petroleum importation, the feasibility of offshore nuclear power plants, and perhaps a better understanding of national ground-water needs.

There are certain to be new political developments in state-federal relations and perhaps state-local relations. In at least one state there has been some discussion of retaining within that state its own petroleum production until the state's own needs have been met, after which export to other states would be allowed. Should this be tried, federal preemption is certain. State authority over the offshore oil fields is certain to be further disputed in Congress and in the agencies. The enormous capital requirements for new utility construction are on a scale which may be beyond the reach of even groups of private companies. Localities or even state or multi-state organizations may enter the business of producing energy, using the inherent advantages of government bonding and taxing power to generate

capital.

6.6.3 INTERNATIONAL POLITICS

It is probable that the single greatest political impact of a well-developed hydrogen energy system would be international rather than national. Its impact would be more in terms of what it might prevent than what it would cause. Every study surveyed has been in agreement that, for at least the next several decades, the oil resources of the Middle East will play a crucial role in the world's political and economic life. The Middle East is the only place which can possibly supply the vast oil demand of the great industrial countries in Europe, in Japan and in the United States. Even if hypothetical and optimistic domestic oil discoveries are made in the next decade, there is no short-term way to avoid this dependence on Middle Eastern oil.

The dimensions of that dependence, in national security terms, are staggering. The National Petroleum Council's 1972 projections indicate that by 1985, the United States may import as much as 50 percent of its total petroleum consumption or, in other words, may import as much in 1985, as was consumed in 1970. Hottel (6-74) considers an optimistic case in which the 1985 projected oil deficiency of 16 million barrels per day would require approximately 350 oil tankers of 250,000 tons each (currently classed as supertankers but smaller than ships now being built) to supply that need. This requires handling an average of one giant tanker every two hours, and means an enormous capital investment in both tankers and superports. It also poses probably the insoluble problem of air and naval defense of many enormous ships (high-value targets) which must follow restricted routes and schedules.

Another international crisis which is growing quite rapidly is the imbalance of international payments represented by oil imports. By 1985, America's balance of payments deficit per year for petroleum alone may range from \$30 billion to as high as \$70 billion. Hottel (6-74) has cited a study by the Continental Oil Company in which the potential total flow of funds from the United States, Europe and Japan to the eleven members of the Organization of Petroleum Exporting Countries (OPEC) may amount by 1985, to as much as \$500 billion per year. But a balance of payments deficit is more than simply a problem of finding the money with which to pay. It raises such questions as whether the United States can or should allow Saudi Arabia to purchase, as an example, Texaco Oil Company. European and Japanese fears of American purchase of their domestic industries may be replaced by American

fears of foreign ownership of our essential domestic industries. Indeed, since all the industrial countries are more or less dependent on the Middle East for oil (Japan perhaps most remarkably so, being without domestic supplies) world-wide balance of payments problems may be forced upon all countries as the Middle-Eastern nations seek foreign investment opportunities. On the other hand, if supplies become restricted, the United States may find itself in uncomfortable competition for energy with its current allies.

In this context, hydrogen presents some extremely attractive possibilities for both international economic balance and national security. It is worth noting that since Russia and China will probably continue to be much more petroleum self-sufficient in petroleum than the United States, they will gain relatively as American self-sufficiency declines. The United States found in Viet Nam that its military operations are extremely fuel-dependent, particularly as distance from this country increases logistic requirements. In fact, defense is already over 50 percent dependent on foreign oil sources. Vansant (6-84) has shown that in 1968, the United States military procured approximately 58.5 percent of its fuel from domestic sources and the remainder directly from foreign sources. However, since the domestic supply already included approximately 20 percent foreign supplies, the military's 58.5 percent included nearly 12 percent which originated overseas. This means that in 1968, the United States' military was already some 53 percent dependent on foreign oil. As the fuel import ratio increases in the future so will this dependency ratio.

Civilian economic reasons also exist for minimizing dependence on petroleum imports since a blackmail cut-off of supplies by the OPEC countries, or a war-time interruption, or large scale sabotage would create severe shortages in the civilian economy. A July 24, 1973, statement by the National Petroleum Council (6-85) suggests that by 1978, a maximum of two million barrels per day of oil could be saved, under emergency conditions, if previously-planned voluntary and mandatory restrictions could be invoked. Saving a maximum of two million barrels per day is not very comforting when compared to their own demand estimates that approximately six million barrels per day would be the minimum imported quantity of oil in 1980. This would leave an absolute deficit of at least four million barrels per day or some 20 percent of the total oil consumption estimated for that date, even with the recommended controls in effect.

Developing integrated hydrogen energy systems for military use would both reduce

United States' import requirements and perhaps provide increased military capabilities. Vansant (6-84) and Hallet (6-86) have both studied the potential use of synthetic fuels, such as hydrogen, for military purposes. Since hydrogen-fueled aircraft have already flown several test missions and there seem to be few significant technical barriers to overcome, this avenue should be explored. As an example of a potential weapons system, consider a nuclear powered aircraft carrier equipped with high-performance hydrogen-powered aircraft. Since the carrier power plant seldom operates at peak power, it could routinely be used to generate hydrogen through electrolysis for on-board storage and use by its complement of aircraft. The range and time-at-sea capability for the system would be greatly extended since the carrier could constantly replenish the aircraft fuel stores. This should also result in cost savings in terms of fuel depots and perhaps even in the very expensive necessity of maintaining a large fleet of carriers on station and in port. Additionally, it would result in a balance of payments savings and render the military less dependent on foreign fuels. Similar possibilities for improved capability and economic savings exist in use of hydrogen as a fuel for civil or military aircraft.

Finally, it may be suggested that an American-developed hydrogen energy technology would be an exportable item, thus reducing dollar outflow and possibly even partially reversing the flow. In view of the present intensive work on hydrogen being done at Ispra, Italy, American research should be accelerated lest this advantage be lost.

6.6.4 DOMESTIC POLITICS

Domestically, hydrogen offers several advantages. Since a new fuel is essential, political costs are reduced to the degree that the new system is technically, economically, and politically compatible with the previous system. Here we find that hydrogen can fill nearly every role now played by natural gas, and can do so in much the same way. In other words pipeline companies should welcome rather than resist hydrogen as a fuel; utilities can use hydrogen as a peak-shaving auxiliary, as a boiler fuel substitute, or as a natural gas substitute for eventual residential distribution; and even the energy companies may fit hydrogen into their nuclear and chemical divisions. Workers and unions in energy-related areas should face minimal employment and retraining adjustments. There is the further political boon that hydrogen, widely cited as an eco-energy, genuinely is an environmentally desirable fuel. Its combustion product is water, which makes it eminently recyclable since its source is also water. The environmental problems associated with

hydrogen are nearly all related to the primary source of power to produce the hydrogen, not to hydrogen itself. Since the source is likely to be coal or nuclear power, there is no totally new political or economic factor to be adjusted by the political system.

Politically and economically, hydrogen and electricity are both natural competitors and naturally complementary. Either is convertible into the other; either is environmentally clean (absent consideration of the original power source); and either is quite flexible in application. If nuclear power plants must be sited remote from load centers, and particularly if environmental pressures force electric transmission underground, hydrogen fuel should be a clear favorite over electricity. Since it is technically and economically improbable that hydrogen/electricity is an either/or situation, a satisfactory mix of the two can develop over time with minimal disruption by utilities and energy companies.

6.6.5 CONCLUSION

There is a very serious, potentially revolutionary political content in the energy shortage. The entire American economy, many social values and major political patterns depend upon massive and growing quantities of (relatively) cheap energy. Suggestions that we may be forced to reduce our energy consumption are usually considered crackpot solutions. Despite pleas to conserve energy by driving more slowly, change the thermostat setting or make some other saving in energy consumption, the emphasis is nearly always on ways in which supplies can be increased to meet the demand. The present shortage is viewed as real but temporary. Suggestions for real and permanent reductions in energy consumption are greeted with warnings of stagnation, unemployment, reduced living standards, loss of international status, and a host of other penalties (6-87). Senator J. W. Fulbright, who has built his reputation in recent years on opposing military intervention abroad, has suggested the distinct possibility that a growing petroleum shortage may lead to American and European military seizure of Middle Eastern oil fields (6-88). Clearly then there is potentially enormous political conflict involved in energy matters, and of a different type than the fairly well understood and endemic conflict between public and private power, or the perennial maneuverings over the oil depletion allowance. Those have been marginal frictions over how and on what terms energy would be provided compared to the now wide-open question of whether energy can be or should be provided.

Hydrogen is no solution to the energy

shortage despite the occasional hyperbole. As this report makes clear, hydrogen is not a source of power but a means by which energy may be transported and stored. If the primary power problem can be solved, hydrogen does offer several advantages over our current extreme dependence upon hydrocarbon fuels. In this sense it can contribute to an easing of the shortage and become a part of our normal energy system by buying time during which more permanent solutions can be found.

6.7 CONCLUSIONS

Industrialized, high-technology society rests upon a base of energy, but each different application method exerts peculiar effects upon the larger social context. A large scale hydrogen economy will necessitate some definite changes in safety codes and procedures, and will certainly alter existing economic flows, both domestic and international. Legal provisions, political power and pressures, and environmental constraints must be redesigned and recalculated. But, similar changes have been experienced before, as the nation went from wood to coal, from coal to petroleum, and--perhaps more apropos the hydrogen economy--as natural gas use spread swiftly during the 1950's.

We are now beginning another change in our energy base, but this time there are several complications: it is neither clear what the new energy base will be nor is it clear what medium will be chosen to carry and distribute the energy. We may be moving toward a very mixed-base power system where nuclear (fission, breeder and even fusion) will coexist with solar, geothermal, ocean temperature gradients, and perhaps many others, even more exotic. We may use electricity to distribute the base power, or we may use hydrogen. There are complications to this energy change. For the first time, environmental preservation has become a general force in society with legal, political and economic muscle unknown in prior energy/society relationships. We are even beginning to face the certainty that infinite growth in all things is not a real possibility, which leads inexorably to a previously unthinkable question: If we must stop growth, when and on what terms shall we stop?

The United States now depends very heavily upon petroleum energy. Since we are no longer self-sufficient in petroleum energy, and since we already use far more than a proportional share of the world's scarce hydrocarbon resources, we must move away from that potentially precarious base as rapidly as possible. It would indeed be sobering to find ourselves faced with a choice of sudden and drastic curtailment in energy consumption, and consequent economic dislocation, or a military takeover of oil fields in other countries, the type

of imperialistic betrayal of our social and political heritage which Senator Fulbright has recently foreseen. Hydrogen can help render this country more self-sufficient provided that the scientific, engineering and environmental problems of developing any of several possible base power sources can be resolved. It offers environmental advantages over other energy carriers, even electricity, in transmission and in some forms of use. But it also has limitations.

The largest single obstacle to a hydrogen economy is probably public fears about safety. It is widely believed that hydrogen is a dangerous substance. This belief is correct. However, all forms of energy are dangerous, if improperly used. There must be few Americans indeed who have not experienced energy hazards and accidents: pilot lights go out and are relit with a great whoosh and singed eyebrows, gasoline is poured on backyard barbecues, electric appliances are plugged in while standing in the bathtub. We have learned to live with such risks. Much of the fear of hydrogen is based on unfamiliarity coupled with the image of a famous disaster. Given timely enactment of the necessary safety codes and the application of what is largely state-of-the-art technology to safety devices, the remaining requirement will be public education. Every parent and elementary school teacher already conducts education in energy safety, as do private and public agencies. The same can be done for hydrogen. It is even possible that initial public concern may lead to development of a hydrogen energy system hedged with safeguards which render it actually safer than is our present system. Hydrogen then is dangerous in different ways than is gasoline, natural gas or electricity, but is not necessarily an absolute danger. We believe that society can learn to protect itself from most errors and live with the remaining risk, as we already do with existing energy systems.

SELECTED REFERENCES

- 6 -1 David, E. E., "An Energy Policy from the Federal Standpoint", *CEP*, V. 69, n. 6, pp., 22-26, June, 1973.
- 6 -2 1972 FPC Ann. Rep. 27.
- 6 -3 86 ICC Ann. Rep. 133, Table 4, (1972) (1970 figures).
- 6 -4 Compare Northern States Power Co. v. Minnesota, 447 F. 2d 1143 (8th Cir. 1971), aff'd mem., 405 U.S. 1035 (1972), with Crowther v. Seaborg, 312 Supp. 1205 (D. Colo. 1970).

- 6 -5 30 USC §§801-960 (1970).
- 6 -6 29 USC §§651-78 (1970).
- 6 -7 Comment, "OSHA: Employer Beware", 10 *Houst. L. Rev.*, 426, 437, (1973).
- 6 -8 Northern States Power Co. v. Minnesota, 447 F. 2d 1143 (8th Cir. 1971), aff'd mem., 405 U.S. 1035 (1972).
- 6 -9 Rosen, B., Dayan, V. H., Proffit, R. L., "Hydrogen Leak and Fire Detection", NASA SP 5092, 1970.
- 6-10 Gregory, D. P., "A Hydrogen Energy System", American Gas Association and Institute of Gas Technology, August, 1972, pp. IV-3 to IV-7.
- 6-11 Table adapted from Gregory (6-10), Rosen (6-9), Zabetakis, M. G., Safety with Cryogenic Fluids, Plenum Press, New York, 1967; Bernard, L., Von Elbe, G., Combustion, Flames and Explosions of Gases, Academic Press, Inc., 1961; Drell, I. L., Belles, F. E., "Survey of Hydrogen Combustion Properties", NASA 1383, 1958; National Fire Protection Agency, "Fire Protection Guide on Hazardous Materials", 1967; National Fire Protection Association, "Fire-Hazard Properties of Flammable Liquids, Gases and Volatile Solids", n. 325, May, 1960.
- 6-12 Business Week, September 23, 1972, quoting Union Carbide's Product Manager for hydrogen, Stanford H. Henry.
- 6-13 Gregory (6-10), pp. VIII 11-13.
- 6-14 Netschert, B. C., "The Energy Company: A Monopoly Trend in the Energy Markets", *Bull. At. Scientists*, V. 27, n. 8, pp. 13-17, October, 1971.
- 6-15 93 S. Ct. 1870 (1973).
- 6-16 93 S. Ct. 1022 (1973).
- 6-17 *Houston Post*, July 10, 1973, §A, at 15.
- 6-18 *Houston Post*, July 18, 1973, §A, at 1.
- 6-19 *United States v. Fuller*, 93 S. Ct. 801 (1973).
- 6-20 *Almota Farmers Elevator & Whse. Co. v. United States*, 93 S. Ct. 791 (1973).
- 6-21 312 F. Supp. 1205 (D. Colo. 1970).
- 6-22 *FPC v. Louisiana Power & Light Co.*, 92 S. Ct. 1827, 1833 (1972).
- 6-23 3 *BNA Environ. Rep.* 1378 (1973).

- 6-24 Lueck, D. W., "Energy and the Environment", G. E. Co. TEMPO, GE72 TMP-57, p. 51, December, 1972.
- 6-25 42 USC §§4321-47 (1970).
- 6-26 Bonavita, "Would Casey Pull EPA's Teeth", Houston Post, July 24, 1973, §1, at 2.
- 6-27 New Hampshire v. AEC, 406 F. 2d 170 (1st Cir. 1969), cert. denied, 395 U.S. 962 (1969).
- 6-28 Calvert Cliffs Coordinating Comm. v. AEC, 449 F. 2d 1109 (D.C. Cir. 1971).
- 6-29 42 USC §1857 et seq (1970).
- 6-30 344 F. Supp. 253 (D.D.C. 1972), aff'd per curiam, 93 U.S. 2770 (1973) (4-4 decision).
- 6-31 86 Stat. 816 et seq; P.L. 92-500 (1972).
- 6-32 33 USC §401 et seq.
- 6-33 93 S. Ct. 1804 (1973).
- 6-34 Howard, A. E., "State Constitutions and the Environment", 58 Va. L. Rev. 193 (1972).
- 6-35 381 U.S. 479 (1965).
- 6-36 Sax, J. L., "The Public Trust Doctrine in Natural Resource Law; Effective Judicial Intervention", 86 Mich. L. Rev., 471 (1970).
- 6-37 405 U.S. 727 (1972).
- 6-38 Stone, C. D., "Should Trees Have Standing? - Toward Legal Rights for Natural Objects", 45 S. Cal. L. Rev. 450 (1972).
- 6-39 93 S. Ct. 1854 (1973).
- 6-40 Utton, A. E., "International Environmental Law and Consultation Mechanisms", 12 Colum. J. Transnat'l L. 56, 60 (1973).
- 6-41 Comment, "Civil Liability for Oil Pollution", 10 Hous. L. Rev. 394, 399 (1973).
- 6-42 Comment, "Proper Time Limitations on Outer Continental Shelf Leases Under the National Environmental Policy Act", 10 Hous. L. Rev. 158 (1972).
- 6-43 Winter, "The National Environmental Policy Act and its Relation to Off-shore and Maritime Activities", 9 Hous. L. Rev. 700 (1972).
- 6-44 Convention on the Territorial Sea and the Contiguous Zone (done April 29, 1958), 15 UST 1606, 516 UNTS 205, in force September 10, 1964.
- 6-45 Convention on the Continental Shelf (done April 29, 1958), 15 UST 471, 499 UNTS 311, in force June 10, 1964.
- 6-46 Convention on the High Seas (done April 29, 1958), 13 UST 2312, 450 UNTS 82, in force September 30, 1962.
- 6-47 Brown, E. D., "International Law and Marine Pollution: Radioactive Waste and 'Other Hazardous Substances'", 11 Nat. Res. J. 221 (1971).
- 6-48 G. A. Res. 2749, par. 11, 25 U.N. GAOR Supp. 28, at 24, U.N. Doc. A/8028 (1970), 64 Dep't State Bull. 155 (1971).
- 6-49 3 Environment L. Rev. 695 (1972).
- 6-50 Edwards, D. J., "A Proposal for Participating in Natural Resource Development Starting with the High Seas", 11 Nat. Res. J. 636 (1971).
- 6-51 Haight, G. W. "The Seabed and the Ocean Floor", 3 Int'l L. 642 (1969).
- 6-52 Darmstadter, J., Energy in the World Economy, Johns Hopkins Press for Resources for the Future, 1971.
- 6-53 Cook, "The Flow of Energy in an Industrial Society", reprint from Scientific American, September, 1971.
- 6-54 Caldwell, K., Environment: A Challenge for Modern Society, Natural History Press, 1970.
- 6-55 Lueck, D. W., "Energy and the Environment", General Electric Co. TEMPO GE 72 TMP-57, 1972, p. 10.
- 6-56 Martin, G., "Some Possible Approaches to Environment", Social Science Information, October, 1971.
- 6-57 Sachs, "Approaches to a Political Economy of Environment", Social Science Information, October, 1971.
- 6-58 Coddington, A., "The Economics of Ecology", New Society, April 9, 1970.
- 6-59 Ridker, Economic Costs of Air Pollution: Studies in Measurement, Praeger, 1967, p. 159.
- 6-60 Davies, J. C., The Politics of Pollution, Pegasus, 1970, Chapter 4.
- 6-61 Brecher, J. J., Nestle, M. E., Environmental Law Handbook, Calif. Cont. Educ. of the Bar, 1972.

- 6-62 Kolshus, H. J., "Common Property Resources and the Invisible Hand", in Environmental Quality and Social Responsibility, Khare, R. S., Kolka, J. W., and Pollis, C. A., eds., Univ. of Wisconsin, Green Bay, Wisconsin, 1972.
- 6-63 Weinberg, M., "Can Technology Replace Social Engineering?", The University of Chicago Magazine, October, 1966; reprinted in Mesthene, F. G., ed., Technology and Social Change, Bobbs, Merrill, 1967.
- 6-64 National Academy of Sciences, Technology: Processes of Assessment and Change, Washington, 1969.
- 6-65 Daly, H. E., Toward a Steady-State Economy, W. H. Freeman, 1973.
- 6-66 Commoner, B., The Closing Circle, Alfred A. Knopf, 1971.
- 6-67 Pearl, A., "An Ecological Rationale for a Humane Service Society", Social Policy, September-October, 1971.
- 6-68 Pacific Northwest Labs, Battelle Memorial Institute, "A Review and Comparison of Selected U.S. Energy Forecasts", December, 1969 (Prepared for Office of Science and Technology in the Executive Office of the President).
- 6-69 Morris, D. N., "Future Energy Demand and its Effect on the Environment", Rand Corp., 1972, prepared for the National Science Foundation, R-1098-NSF.
- 6-70 Hannon, B. M., "System Energy and Recycling: A Study of the Beverage Industry", C.A.C. Document 23, University of Illinois, January, 1972; also by the same author, "Bottles, Cans, Energy", Environment, March, 1972.
- 6-71 Energy Economics Division, Chase Manhattan Bank, "Capital Investments of the World Petroleum Industry, 1971", Chase Manhattan Bank, New York, 1972, p. 4.
- 6-72 U. S. Energy Outlook: A Summary Report of the National Petroleum Council, National Petroleum Council, December, 1972, p. 9.
- 6-73 Winger, G., Vice President, Chase Manhattan Bank, personal communication, July 10, 1973.
- 6-74 Hottel, H. C., "Challenges in Production of Fossil Fuels", Chemical Engineering Progress, June, 1973.
- 6-75 Professional Engineer, March, 1973, pp. 22-23.
- 6-76 Frey, D. N., "The Colossus That is Detroit", Innovation, October, 1969.
- 6-77 Fortune, June, 1973, p. 121.
- 6-78 David, E. E., "An Energy Policy from the Federal Standpoint", Chemical Engineering Progress, June, 1973.
- 6-79 Weir, J. P., "Coal Supply for Gasification Plants", paper presented at the 1973 Coal Convention, American Mining Congress, Pittsburgh, Pennsylvania, May 6-9, 1973.
- 6-80 Meadows, D. H., Meadows, D. L., Randers, J., Behrens, W. W. III, The Limits to Growth, New American Library, 1972.
- 6-81 Seidman, A., "Barriers to Technical Innovation", Bulletin of the Atomic Scientists, March, 1971.
- 6-82 Senate Committee on Interior and Insular Affairs, "Federal Energy Organization", G.P.O., Washington, 1973.
- 6-83 "Statement by the President", Office of the White House Press Secretary (mimeo), June 29, 1973.
- 6-84 Vansant, C., Strategic Energy Supply and National Security, Praeger, New York, 1971, p. 51.
- 6-85 Houston Post, July 25, 1973, § F, at 3.
- 6-86 Hallet, N. C. et al, Study, Cost and System Analysis of Liquid Hydrogen, NASA, Ames Research Center, NASA Report n. 73-226 (1968).
- 6-87 For example, Gambs, G. C., "The Energy Crisis in the United States", American Paper Industry, May, 1973, pp. 39-41.
- 6-88 Houston Post, July 24, 1973, § A, at 15.

ADDITIONAL REFERENCES

- Cloyd, D. R., Murray, W. J., "Handling Hazardous Materials", NASA SP-5032, 1965.
- Compressed Gas Association, "Standard for Gaseous Hydrogen Systems at Consumer Sites", Pamphlet G-51.
- Coward, H. F. and Jenks, G. W., "Limits of Flammability of Gases and Vapors", U.S. Bureau of Mines Bulletin 503, 1952.
- Egerton, A. C., Limits of Inflammability, Williams and Wilkens, Baltimore, 1953.

"Hydrogen Safety Manual", Advisory Panel
on Experimental Fluids and Gases, Lewis
Research Center, NASA TM-X-52454, 1968.

Zabetakis, M. C., "Flammability Character-
istics of Combustible Gases and Vapors",
U.S. Bureau of Mines Bulletin 627, 1965.

N74-11735

ORIGINAL PAGE IS
OF POOR QUALITY

CHAPTER 7

IMPLEMENTATION OF A HYDROGEN ENERGY CARRIER SYSTEM

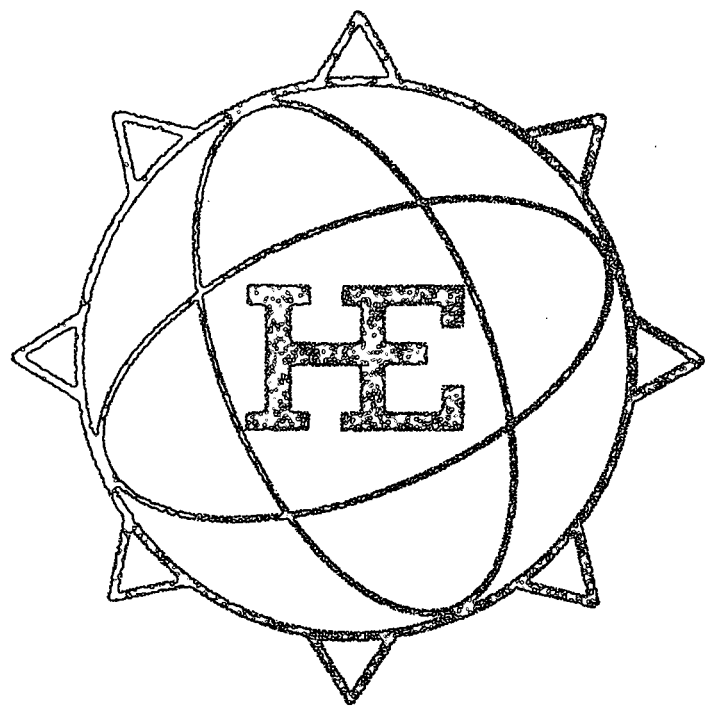

7.1 POSSIBILITIES FOR IMPLEMENTATION

The results of the analyses in this report indicate that hydrogen can be used in most applications as an energy carrier. Hydrogen, produced by any of several different methods, can be stored and transported. None of the nontechnical problems in the use of hydrogen appear to prohibit its use. The cost of hydrogen may be competitive with conventional fuels in the future or it may cost more, depending on how, when and where it is produced. The favorable environmental aspects of hydrogen fuel may justify a higher cost.

Hydrogen is currently used in many industrial-chemical processes, but it is usually obtained from natural gas and naphtha which are becoming increasingly scarce and expensive. We believe that hydrogen can be used in existing industrial space and process heating equipment as soon as hydrogen can be made available. Electric power generation, using hydrogen as a peak-shaving fuel and as an energy storage system, is now in the developmental stage and shows considerable promise.

Residential and commercial use will occur later in the development process for the following reasons:

- The volumes required would be quite large,
- The necessary conversions would be expensive without a preparatory period,
- The complexity of possible applications would require careful development of designs, safety procedures, and installation codes,
- Time will be needed to plan, engineer, and implement the systems.

7.2 GENERAL CONSIDERATIONS

Hydrogen fuel implementation must proceed by integrated steps for two reasons:

- Production and use volumes must be properly co-ordinated to facilitate hydrogen system development,
- The hydrogen energy system must develop from the established methods of production, distribution, and use, then progress toward the unproved possibilities.

We are now able to suggest a program of implementation based upon the above factors. Although large tonnages of hydrogen are used in the chemical industry,

there is no established market for hydrogen as a fuel except in the space industry. We believe that direct experience in the production, transportation, and use of hydrogen as an energy carrier is needed to demonstrate its feasibility for use in the nation's energy systems. Our concept is that maximum participation by industry is needed to establish hydrogen as a fuel. Few industries are in a position to undertake such a large project on a proprietary basis, yet the maximum benefits of developing a new technology would not be realized if it were a totally government funded project.

7.3 IMPLEMENTATION BY STAGES

7.3.1 STAGE I - COAL GASIFICATION PROJECT

Demonstration plants for synthetic natural gas have been jointly financed by industry and government, but in these cases a ready market for the synthetic gas is available. In the case of hydrogen, a market as well as methods of production and transmission must be developed. We propose that a demonstration hydrogen complex (Hyplex) be structured as follows: A power plant could be sited in the general areas of Joliet, Illinois; Pittsburgh, Pennsylvania; St. Louis, Missouri; or any of several other locations. Joliet will serve here as the example. Nearby are found coal fields in which gasification plants could be built. Suitable underground formations for large volume storage are also found nearby. The area has a number of utilities with aged boilers which could be replaced by a hydrogen-burning system such as that now being tested by Rocketdyne and Commonwealth Edison Companies at Joliet. Relatively short pipeline runs could reach the steel mills around Gary, Indiana and the oil refineries near Whiting, where hydrogen could be used.

The participating power plant would be selected on the basis of its willingness to shift to hydrogen as a fuel. The supply of hydrogen fuel would be solicited by bids at a fixed price on a long-term basis - say 10-15-20 years. The difference in cost between hydrogen fuel and a conventional fuel could be subsidized by a grant from the Ford Foundation or by a government subsidy. An offsetting factor for this fuel cost is a savings in both capital and operation cost since this plant will not require the installation of pollution abatement equipment.

The advertisement for bids would stipulate that the hydrogen fuel would be produced by a new technology and that the hydrogen would be transmitted some minimum distance, for example 200 miles. The bidder would be permitted to quote a price

which, over the life of the contract, would recover the development, design, capital, and operating costs. The amount of profit would depend on the bidder's ability to keep costs down while fulfilling the contract. The incentive to the bidder would be a guaranteed market for 10 or more years while the technology is being developed. The bidder would be free (and would be encouraged) to develop other markets. This Hyplex could be designed in almost any basic unit size, and then expanded as other users convert to hydrogen.

In stage I, gasification of coal would be the source of hydrogen in order to develop this technology.

7.3.2 STAGE II - HYDROGEN VIA NUCLEAR POWER

An arrangement with a utility willing to shift to hydrogen as a fuel should also be based on hydrogen produced by electrolysis of water using electric power from a nuclear power plant or by direct thermochemical conversion of water using high temperature heat from a nuclear reactor. The hydrogen production plant could be part of an off-shore nuclear plant or it could be located in a desert. The hydrogen would be transmitted by pipeline to the electric power plant or industrial customers in an area with pollution problems, such as Los Angeles.

Either Stage I or Stage II should offer benefits to both industrial and governmental decision-makers. Rising costs of fuels and pollution control equipment should provide industrial users an incentive to support a demonstration plant; environmental gains and the generalized pressures upon society's energy base should provide governmental incentives. It is very possible that the widely-forecast rises in natural gas prices (some of which have already taken place) will reduce the price gap between natural gas and hydrogen and make the concepts even more attractive.

7.3.3 STAGE III - MODEL HYDROGEN CITY

Assuming that experience with the Hyplex is satisfactory, we propose the development as early as 1980 of a small integrated system of industry, commercial and residential hydrogen use. This hydrogen-fueled city (Hycity) would provide a test for many residential uses not possible to duplicate in the laboratory.

As a candidate for Hycity, an interesting possibility may exist. By 1985 it will be necessary for the United States to construct a new nuclear fuel enrichment facility. Both governmental and private industry interest in this facility is very high, and financial planning is already under way. Such a plant will require 2000

megawatts of base power for the enrichment facility and, importantly from our standpoint, it will also require 1000 megawatts of stand-by power to avoid critical damage to the fuel processing plant in case of power failure. Its normal output, however, could be used to supply hydrogen to the residential and commercial sectors of the small city which exists to service the plant.

If the plant provides primary employment for approximately 500 people, the city should have a total population of 10,000 people. Because of the nature of the technology involved, the educational level and relative energy sophistication of the residents of the city should be of great value in this experimental application of hydrogen fuel. Further, since the plant may be located in any of several remote areas and will probably be a totally new installation, it will be necessary to build a new city as well. If this new city is equipped originally for hydrogen operation, there will be no conversion costs.

7.3.4 STAGE IV - MODEL HYDROGEN SOCIETY

As a last step between Hycity and major segments of the entire national economy, we suggest conversion to hydrogen of an island isolated from the mainland supply systems. The State of Hawaii is an obvious example. It possesses supplies of solar, geothermal and wind energy, and could also be the site of on- or off-shore nuclear plants. It now must import all its fossil fuels, which are high-priced. Because of its relative isolation, conversion of appliances could be more easily controlled and planned than in mainland areas. A hydrogen economy could thus be more easily introduced, and initially would be more cost-competitive than in most mainland locations. The short distances involved for auto travel would favor the development of hydrogen fuel based or electric automobiles. Because so much of Hawaii's economy depends upon maintenance of its environmental attractions, a non-polluting energy system represents real and measurable social benefits. Lastly, Hawaii in general possesses a high-technology societal base.

7.4 LONG RANGE RECOMMENDATIONS

Movement toward a full-scale hydrogen economy would be assisted by timely beginnings in several areas. At some early point it would be appropriate to pass a 'TV law', similar to the requirement some years ago that all TV sets manufactured after an established date must be equipped for reception of both VHF and UHF signals. A similar requirement that appliances using burners should be designed for dual hydrogen/natural gas operation, or for

rapid and inexpensive conversion, would greatly ease the cost and time requirements for eventual conversion. Introduction of appropriate educational materials in the schools and other educational outlets would also be desirable at an early date.

Legal and political preparations would be necessary. Development of the necessary safety codes, regulatory mechanisms, and associated federal-state-local requirements will be needed and should be prepared in advance of conversion or large scale Hyplex implementation. Environmental impact statements, for example, might be required to evaluate the possibility of hydrogen as an alternative fuel in any proposed installation.

Attention to the international law aspects of off-shore power plant sites and of large-scale use of ocean water deserve more consideration than has been given in the past. The international implications of making the United States less dependent on fuel from the Middle East are also worthy of exploration.

APPENDIX A
PROPERTIES OF HYDROGEN

PRECEDING PAGE BLANK NOT FILMED

PHYSICAL PROPERTIES OF HYDROGEN

LIQUID

Melting point at atmospheric pressure, °F	-434.6
Boiling point at atmospheric pressure, °F	-422.9
Critical temperature, °F	-400
Critical pressure, psia	191
Specific gravity (liquid water = 1.00)	0.07 (4.37 lbs/ft ³)
Density (liquid), lb/gal (at -422.9°F and 30 in. Hg)	0.583
Specific heat, Btu/lb °F	0.57
Viscosity (at normal b.p.), poises	182 x 10 ⁻⁶
Heat of fusion, Btu/lb	25.2
Inversion point, Joule Thomson	-92°F
Heat of vaporization (nearly all para), Btu/lb	190.5

GAS

Specific gravity 68°F (air = 1.00)	0.06953
Density, lb/ft ³ (60°F and 30 in. Hg)	0.00532
Specific volume, ft ³ /lb (60°F and 30 in. Hg)	187.9
Gross heat of combustion, Btu/ft ³ (incl. latent heat energy of steam)	325.1
Gross heat of combustion, Btu/lb (incl. latent heat energy of steam)	61,084
Btu/ft ³ of gas/air mixture (F/A ratio 0.420 vol. 0.020 wt.; or 28.7% H ₂ by vol.)	81.3
Ft ³ of air required per ft ³ of combustible	2.382
Pound air required per pound combustible	34.226
Flame temperature (F/A ratio 0.462 vol. 0.0313 wt.; or 31.6% H ₂ by vol.), °F	3,700
Ignition temperature in air (auto ignition), °F	1065
Ignition temperature in oxygen, °F	1040
Flammability limits, % vol. H ₂ in air	4.1-74.2
Flammability limits, % vol. H ₂ in oxygen	4.6-93.9
Detonation limits, % vol. H ₂ in air	18.3-59
Detonation limits, % vol. H ₂ in oxygen	15.0-90
Nonflammable limits, air-hydrogen-carbon dioxide	Less than 8% O ₂
Nonflammable limits, air-hydrogen-nitrogen	Less than 6% O ₂
Emissivity of flame (blackbody = 1.00)	0.085

CHEMICAL PROPERTIES

Hydrogen in liquid or gaseous form will react violently with strong oxidizers such as oxygen and spontaneously with fluorine and chlorine trifluoride.

Hydrogen gas is colorless, odorless, nontoxic (though asphyxiating), and non-corrosive. When its temperature is that of the ambient air, its density is only about 1/14 of the air density, and the gas is thus strongly buoyant; however, the vapor at the boiling point is as heavy as air at 70°F.

Liquid hydrogen is a transparent, colorless liquid of low viscosity. It does not form solutions with any material except, to a slight extent, with helium. In particular, gases like oxygen and nitrogen condense and freeze to solids in liquid hydrogen without entering into solution. At about 14°K (-435°F) liquid hydrogen freezes to a solid. The temperature and pressure at the triple point (at which solid, liquid and gaseous hydrogen

co-exist) are 14.0°K and 0.071 atmospheres for normal hydrogen, and 13.8°K and 0.069 atmospheres for para-hydrogen. Solid hydrogen freezes into a white crystalline or snow-like mass.

Hydrogen diffuses approximately 3.8 times faster than air. A spill of 500 gallons of liquid hydrogen on the ground has diffused to a nonexplosive mixture after about one minute. Air turbulence increases the rate of hydrogen diffusion.

Hydrogen in both the liquid and gaseous states is particularly subject to leakage because of its low viscosity and low molecular weight. Leakage rate is inversely proportional to viscosity. Because of its low viscosity alone, the leakage of liquid hydrogen will be roughly 100 times that of JP-4 fuel, 50 times that of water, and 10 times that of liquid nitrogen. Likewise, the leakage of gaseous hydrogen will be greater than that of air.

Reference: Cloyd, D. R. and N. J. Murphy; Handling Hazardous Materials, Chapter 1,

Liquid Hydrogen, NASA SP-5032, September, 1965.

APPENDIX B
SYSTEMS ANALYSIS

PRECEDING PAGE BLANK NOT FILMED

SYSTEMS ANALYSIS

Since NASA has developed technology in the application of hydrogen to space flight and aeronautical science, a NASA-sponsored study of the use of hydrogen to meet society's energy needs is a natural extension of the Agency's programs. Based on NASA's extensive background in the management of large systems, the Johnson Space Center prepared a work statement which specified the project's objectives and requirements. We were to undertake the following:

- Perform a systems design analysis of hydrogen as an energy carrier,
- Identify the key problems,
- Gather the facts,
- Analyze and evaluate all aspects - technical and nontechnical,
- Report findings with supporting data.

The point of emphasis was "analysis". In the eleven weeks available, we could not expect to undertake laboratory research activities or engage in complete design studies.

The first step was to translate the work statement into a work program which the participants accepted as a reasonable statement of what they could expect to accomplish during the summer. Concurrent with this activity, the group organized itself into task forces to implement the program. These task forces followed the four major sections of the work program:

- Group 1 - Production of Hydrogen
- Group 2 - Storage and Transmission of Hydrogen
- Group 3 - Hydrogen Usage
- Group 4 - Environmental, Economic, Social, Political, Safety and Legal Aspects of a Hydrogen Economy

Since the objectives of the program were denoted in the work statement, we were able to move directly into a systems analysis of the topic. A modification of the systems approach outlined in the UNISTAR (B-1) report was used as the basis for this project. A flow chart for the project is presented in Figure B-1. The milestone dates were determined by backtracking from the final report date and served to alert groups of necessary lead times.

After translation of the work statement objectives into work program objectives, each of the four task groups undertook a literature search which produced data that were interpreted in terms

of the requirements for each group. These were developed into one or more approaches to be considered as potential solutions for the problems.

Each approach within a group was subjected to a trade-off study to select the best system or group of systems. A matrix was developed for the trade-off study (Figure B-2). The matrix included both technical and nontechnical factors which were rated on the basis of a scale from 1 (most favorable) to 5 (least favorable). Whenever actual costs or other factors could be quantified, these figures were used rather than the scale. Each approach was rated within four specific time periods to accommodate future developments.

1. Now to 1975 (now)
2. 1975 to 1985 (near future)
3. 1985 to 2000 (intermediate period)
4. 2000 to 2020 (long range)

The matrix as developed by each group was then matched with the matrices of the other groups to insure compatibility of the entire system. For example, it was decided that any hydrogen production process should deliver hydrogen at a pressure of at least 50 atmospheres to the transmission system.

The systems analysis procedure was found to be effective for a problem of this complexity. Good systematic analysis does not replace the decision maker, but rather it is an aid. When confronted by complex issues, diverse opinions, and alternatives, the analysis helps him zero in on a final decision by doing the following:

- Uncovering irrelevant issues
- Pinpointing crucial assumptions and facts which underlie alternative recommendations, and
- Tracing out the known consequences and costs of each alternative (B-2)

Systems analysis avoids prejudgement of solutions. By developing a matrix of selection criteria, the trade-off study led to the logical selection of recommended systems, but only after vigorous enlightening interaction within each group.

Evaluation and Trade-Off Matrix Instructions

Purpose: To establish a common set of analytic categories and obtain some comparable evaluations for

use in group decision-making.

Method: Each system and subsystem is to be evaluated on the factors listed in the matrix form supplied, for each of the four time periods Now (for baseline purposes), 1975-85, 1985-2000, 2000-2020. Scaled evaluation will be used whenever possible.

Definitions: 0 equal Not Applicable.
1 equals a "most favorable" category; 5 equals a "least favorable." Please be sparing with 1 and 5 ratings.

The sheet attached contains a number of specific categories for your use. Each group may find that its system or subsystem being rated requires addition of

other categories; five numbered but blank spaces are left for this use. If possible please scale your evaluations to allow comparability with the other categories; at least specify units of measurement and/or standard of evaluation.

It is difficult to list all categories which may apply to the many systems under consideration. Do any of the following relate importantly to your system?

- | | |
|--|---------------|
| Convenience | Compactness |
| Land requirements | Aesthetics |
| Flexibility | Fool-proof |
| Acceptability | Image |
| Patentability | Feasibility |
| Maintenance | Profitability |
| Exportability | Portability |
| Private, Government or Mixed Operation | Renewability |

NASA-S-73-2431

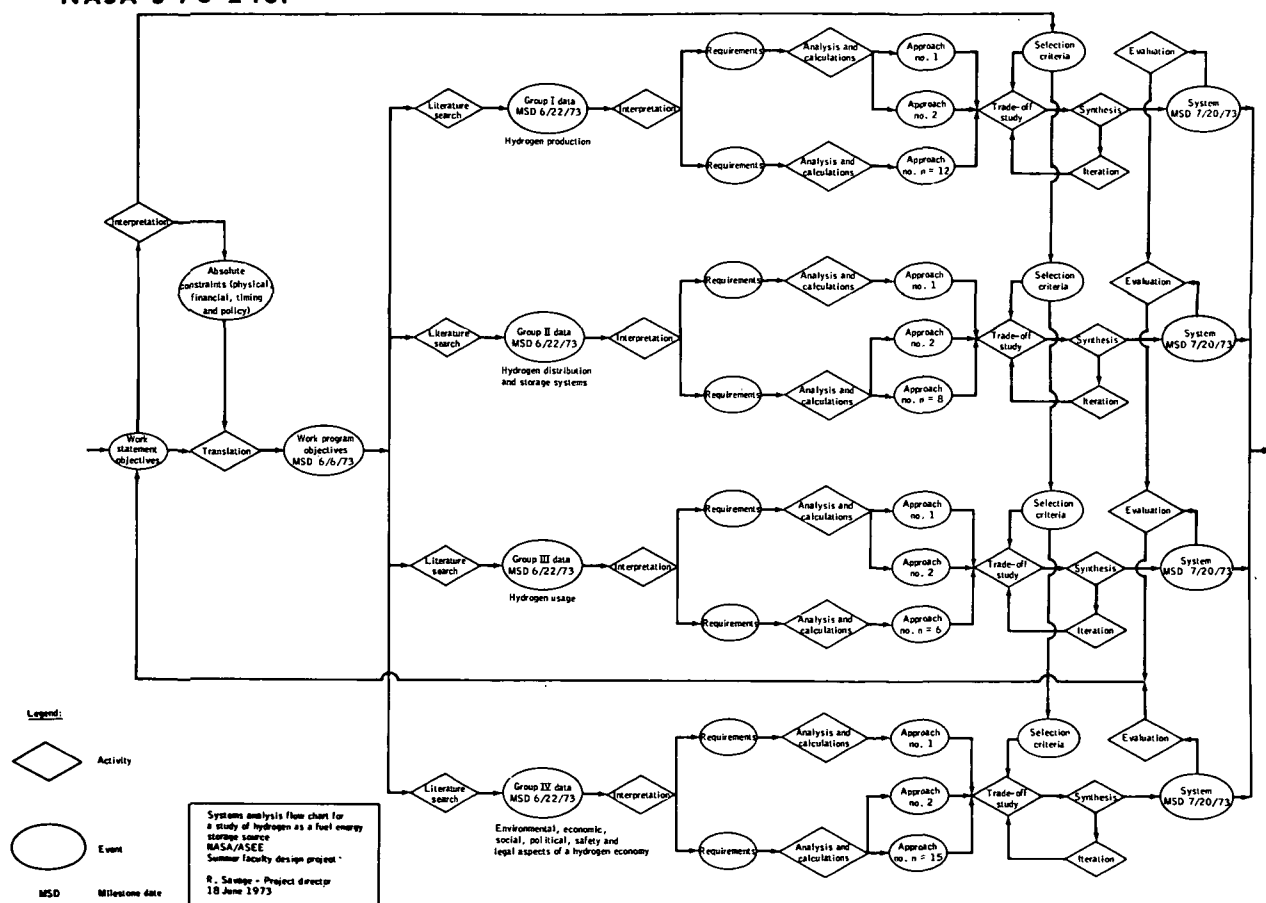

FIGURE B-1
SYSTEMS ANALYSIS FLOW CHART FOR A STUDY
OF HYDROGEN AS AN ENERGY CARRIER

ORIGINAL PAGE IS
OF POOR QUALITY

The matrix scoring sheet contains four rows. Please do your evaluation with one sub-system per sheet, rating one time period in each of the rows, as indicated.

Categories:

1. Necessary technology
 - Is available now
 - Needs commercialization
 - Needs some R&D
 - Needs major R&D work, but probably feasible
 - Is probably not feasible in this time frame
2. Materials needed
 - Are now available and within cost limits
 - Are now available, but expensive or limited supply

Could probably be developed in this time frame
 Require major R&D beyond this time frame
 Are probably not available in this time frame or any future time

3. Compatibility (note: if presently compatible but may present later problems, please note)
 - Wholly compatible with present systems
 - Compatible with minor, inexpensive adaptations
 - Requires major, expensive adaptation
 - Only partly compatible regardless of expense
 - Requires an entire new system
4. Reliability
 - Virtually 100% reliable

NASA-S-73-2432

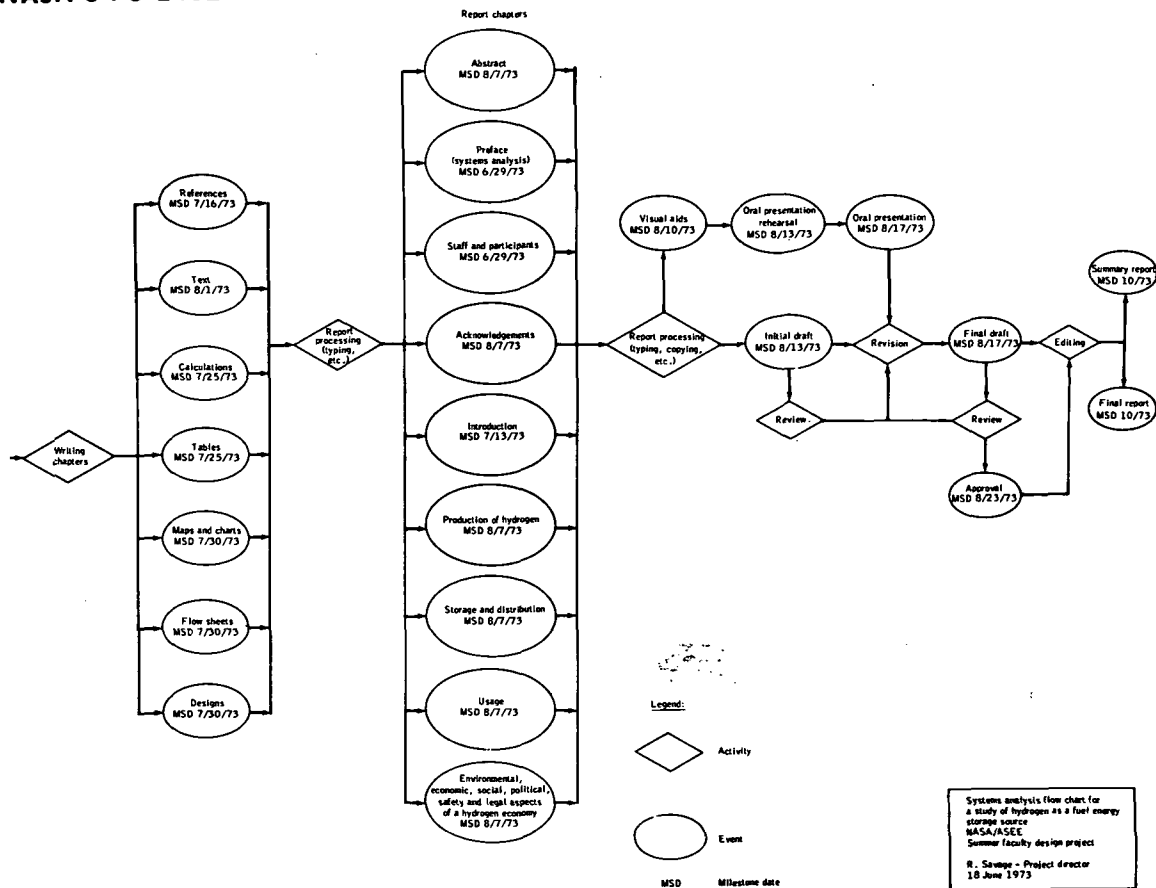

FIGURE B-1 (continued)
 SYSTEMS ANALYSIS FLOW CHART FOR A STUDY
 OF HYDROGEN AS AN ENERGY CARRIER

- Occasional minor, brief outages-- probably predictable, readily repairable
 Usually quite reliable, but occasional major reductions or outages (ref: electricity in New York City)
 Frequent outage or costly, long-term down time
 Not reliable
5. Safety
 Safer than any other operating power source
 Comparable to electricity or natural gas
 Acceptable (e.g., risk levels similar to driving autos)
 Real risk; society must balance risk vs. need
 Dangerous; society must be very reluctant
6. Environment - Air Pollution
 Excellent, non-polluting
 Small pollution, controllable easily
 Local, costly to control but acceptable pollution
 Definite polluter, difficult to control and expensive
 A real mess, actively dangerous to health or corrosive to materials
7. Environment - Aesthetic
 Excellent; contributes to beauty of the site
 Little or no degradation to the site
 No better or worse than we're accustomed to
 Ugly. Should be avoided if at all possible
 Yech! A five garbage-dump equivalent
8. Environment - Water Pollution
 Sparkling clean; Hiawatha's delight
 Clean; drinkable with normal treatment
 Some pollution; cleanable with current normal methods
 Definite pollution; costly, difficult treatment
 Polluted: fish kills, eutrophication
9. Environment - Thermal Pollution
 Minimal, preferably dispersed heat rise
 No observable ecological impacts; acceptable
 Definite rise, but controllable and tolerable
 Pollution; very difficult to control
 Large-scale pollution; major ecological changes
10. Environment - Noise Pollution
 Won't disturb the birds and animals
 Background noise; a quiet air conditioner
 Intermittant loud or consistent moderate noise
 Like living near the airport; objectionable, unsettles nerves
 Dangerous, physical or mental intolerability
11. Environment - Land Use
 Improves present land use; fits nicely
 Minimal land use impact or value impairment
 Requires definite siting studies, some value impairment in neighboring property
 Sprawls, degrades, obstructs - quite objectionable
 Nobody wants to have it around at all
12. Waste Management
 Only "good" wastes (as H₂O), or none
 Small, easily managed waste product
 Large quantities, and/or harder to treat
 Some major problems of treatment or disposal, costly
 Untreatable; very large scale; dangerous
- NOTE: The three questions following on social, political, legal matters are a first pass at spotting trouble and magnitudes. For any energy system or subsystem, there will be S-P-L changes. We ask that you indicate your evaluation of whether the changes will be good, bad or indifferent in each time frame. Thus, will the likely changes fit right in (1), fit with minimal alterations (2), require definite and somewhat controversial action (3), require action which is major and stress-producing (4), or require unacceptable levels of change (5). Please note in more detail the reasons for your decision, for later reference.
13. Social Changes May Have An Effect
 Will fit right in with few difficulties
 Similar to \$250/year luxury tax on automobiles - painful; somewhat discriminatory, but payable
 Similar to required 20% reduction in private auto use
 Similar to restricting private auto use to 2500 miles per year per family
 Similar to a prohibition on private automobile use

14. Political Changes May Have An Effect. Similar To
- Fitting right in with few difficulties
 - Federal preemption from states of all energy regulation powers
 - Expansion of TVA-like complexes to 25-50% of market
 - Establishment of a NEPA-like agency regulating all types of energy activity
 - Socialization of all energy systems

15. Legal Changes Similar to the Impact Of
- Fitting right in with few difficulties
 - A few, low-cost lawsuits and delays - acceptable
 - Delays, expense, controversy - "Alaska Pipeline"
 - Great controversy, expense, delay, requires Congress & Courts to act - compare to Storm King pumped storage case: three times to Supreme Court over 10 year period
 - Unacceptable legal changes - such as a Constitutional amendment expanding Fed. energy powers to near monopoly

- 16.
- 17.
- 18.
- 19.
- 20.
21. The overall energy efficiency of this subsystem is ____%.
22. The variable (operating) cost annually of this system is \$ ____ per 10⁶ Btu
23. The installed cost is \$ ____ per 10⁶ Btu
24. The equivalent annual cost (EAC) per 10⁶Btu is \$ _____, based on a system life span of _____ years.

Note: the formula for equivalent annual cost (EAC) is given here for ten years life span of the system:

$$EAC = (#23) (0.177) + (#22)$$

For a life span of 20 years, the proper factor is 0.134.

For a life span of 30 years, the proper factor is 0.124.

REFERENCES

- B-1 "UNISTAR - User Network for Information Storage, Transfer, Acquisition and Retrieval", NASA CR-6133, 1970.
- B-2 Hinrichs, H. Hand, Taylor, G. M., Program Budgeting and Benefit - Cost Analysis, Goodyear Publishing Company, Inc., p. 153, 1969.

GROUP _____ SYSTEM _____ SUB-SYSTEM _____

MATRIX CATEGORIES	MATRIX CATEGORIES																								NOTES:	
	1. NEEDED TECHNOLOGY	2. MATERIALS NEEDED	3. COMPATABILITY	4. RELIABILITY	5. SAFETY	6. ENVIROMENT - AIR POLLUTION	7. ENVIROMENT - AESTHETIC	8. ENVIROMENT - WATER POLLUTION	9. ENVIROMENT - THERMAL POLLUTION	10. ENVIROMENT - NOISE POLLUTION	11. WASTE MANAGEMENT	12. SOCIAL	13. POLITICAL	14. LEGAL	15.	16.	17.	18.	19.	20.	21. EFFICIENCY	22. VARIABLE COST PER 10 ⁶ BTU _s	23. INSTALLED COST	24. EQUIVALENT ANNUAL COSTS		
<u>NOW</u>																										
<u>1975-85</u>																										
<u>1985-2000</u>																										
<u>2000-2020</u>																										

FIGURE B-2
TRADE-OFF STUDY MATRIX

APPENDIX C
PARTICIPANTS AND CONTRIBUTORS

1973

NASA-ASEE ENGINEERING SYSTEMS DESIGN INSTITUTE

UNIVERSITY OF HOUSTON - JSC - RICE UNIVERSITY

ORGANIZATIONAL STRUCTURE

TEAM LEADER

Robert Savage

GROUP STRUCTURE

PRODUCTION

Kenneth Cox, Leader

Raul Chao
Melvin Eisenstadt
Stamatis Paleocrassas
Richard Williams
Jeffrey Witwer

TRANSMISSION AND STORAGE

Harold Koelling, Leader

Samuel Lee
Leonard Traina
Albert Wilson

USAGE

Richard Murray, Leader

Leland Blank
Richard Johnson
Samuel Powers
Richard Riley

SAFETY, LEGAL, ENVIRONMENTAL,
ECONOMIC, POLITICAL & SOCIAL

Thomas Cady, Leader

Jack Salmon
Representing Other Groups:
Leland Blank
Albert Wilson
Jeffrey Witwer

PRECEDING PAGE BLANK NOT FILMED

1973

NASA-ASEE ENGINEERING SYSTEMS DESIGN INSTITUTE

UNIVERSITY OF HOUSTON - JSC - RICE UNIVERSITY

PARTICIPATING FELLOWS

Leland Thomas Blank, Ph.D.
Assistant Professor
Industrial Engineering
University of Texas - El Paso
El Paso, Texas 79968

Thomas Chapman Cady, L.L.M.
Visiting Professor
Bates College of Law
University of Houston and
West Virginia University
Houston, Texas 77004

Raul Edward Chao, Ph.D.
Associate Professor
Chemical Engineering
University of Puerto Rico
Mayaguez, Puerto Rico 00708

Kenneth Edward Cox, Ph.D.
Associate Professor
Chemical and Nuclear Engineering
University of New Mexico
Albuquerque, New Mexico 87131

Melvin Mortimer Eisenstadt, Ph.D.
Associate Professor
Mechanical Engineering
University of Puerto Rico
Mayaguez, Puerto Rico 00708

Richard T. Johnson, Ph.D.
Associate Professor
Mechanical Engineering
University of Missouri - Rolla
Rolla, Missouri 65401

Harold A. Koelling, Ph.D.
Associate Professor
Materials Engineering
Mississippi State University
Mississippi State, Miss. 39762

Samuel S. Lee, Ph.D.
Associate Professor
Mechanical Engineering
University of Miami
Coral Gables, Florida 33124

Richard George Murray, Ph.D.
Associate Professor & Head
Mechanical Power Technology
Oklahoma State University
Stillwater, Oklahoma 74074

Stamatis Nicholas Paleocrassas, Ph.D.
Associate Professor
Electrical Engineering & Physics
Tri-State College
Angola, Indiana 46703

Samuel O. Powers, M.S.
Assistant Professor
Mechanical Power Technology
Oklahoma State University
Stillwater, Oklahoma 74074

Richard King Riley, Ph.D.
Assistant Professor
Mechanical Engineering
University of Missouri - Rolla
Rolla, Missouri 65401

Jack D. Salmon, Ph.D.
Assistant Professor
Political Science
Virginia Polytechnic Institute
Blacksburg, Virginia 24061

Robert L. Savage, Ph.D.
Professor
Chemical Engineering
Ohio University
Athens, Ohio 45701

Leonard A. Traina, Ph.D.
Associate Professor
Civil Engineering
New Mexico State University
Las Cruces, New Mexico 88003

Richard Dee Williams, Ph.D.
Assistant Professor
Chemical Engineering
University of Arizona
Tucson, Arizona 85721

Albert Eugene Wilson, Ph.D.
Chairman and Professor
Engineering & Nuclear Science
Idaho State University
Pocatello, Idaho 83201

Jeffrey G. Witwer, Ph.D.
Assistant Professor
Aerospace, Mechanical & Nuclear
Engineering
University of Oklahoma
Norman, Oklahoma 73069

GUEST SPEAKERS AND OTHER CONTRIBUTORS

<u>NAME</u>	<u>AFFILIATION</u>	<u>TOPIC</u>
Dr. Glenn Coury	Consultant Denver, Colorado	Geothermal Power
Dr. Steve Dickerson	Associate Professor Mechanical Engineering Dept. Georgia Technological Institute Atlanta, Georgia	Systems Approach to Energy Utilization
Peter Diehl	Associate Professor Office of Professional and Staff Development Miami Dade Community College Miami, Florida	Team Building
Dr. A. F. Hildebrandt	Professor and Chairman Physics Department University of Houston Houston, Texas	Large-Scale Conversion of Solar Energy
James Kelly	Program Manager Rocketdyne, Inc. North American Rockwell 6633 Canoga Avenue Canoga Park, California	Advanced Technology Topping Device for Power Plants
G. Garth Leeth	Tempo General Electric Company 816 State Street Santa Barbara, California	"Eco-Energy"
Dr. J. J. McKetta	E. P. Schoch Professor of Chemical Engineering The University of Texas Austin, Texas	Commentary on the Energy Crisis
John Mixon	Professor Bates College of Law University of Houston Houston, Texas	The Future of Land Use
John Pangborn	Supervisor of Hydrogen Systems Institute of Gas Technology Chicago, Illinois	A Hydrogen Energy System
John Winger	Vice President Energy Economics Division Chase Manhattan Bank New York, New York	Financial Aspects of Energy
Dr. W. G. Wyatt	Associate Professor Mechanical Engineering Department Southern Methodist University Dallas, Texas	Steam Generator
MSFC Systems Design Team	NASA-ASEE Engineering Systems Design Summer Faculty Programs Marshall Space Flight Center Huntsville, Alabama	Solar Energy

ACKNOWLEDGMENTS

The 1973 NASA/ASEE Summer Faculty design fellows wish to express their appreciation to the following people and organizations:

The National Aeronautics and Space Administration and in particular Dr. W. R. Downs, Barbara Eandi, and Pat Elliot, for facilities, funding, and an environment of genuine cooperation to educators.

The University of Houston and in particular Dr. John Howell, Dr. C. J. Huang, and Inez Law; Rice University and in particular Dr. Joel Hebert for extensive planning, which made transition into the summer environment a pleasant experience; for wise leadership which allowed maximum utilization of each individual's talents; and for a deep concern that the summer effort be equally an educational experience as well as an approach to team problem solving.

PRECEDING PAGE BLANK NOT FILMED