

NASA TECHNICAL NOTE



NASA TN D-7333

NASA TN D-7333

(NASA-TN-D-7333) DESIGN AND EVALUATION OF CONTROLS FOR DRIFT, VIDEO GAIN, AND COLOR BALANCE IN SPACEBORNE FACSIMILE CAMERAS (NASA) 33 p HC \$3.00 CSCL 14E

N74-12010

Unclas
H1/10 - 23462

ORIGINAL CONTAINS
COLOR ILLUSTRATIONS

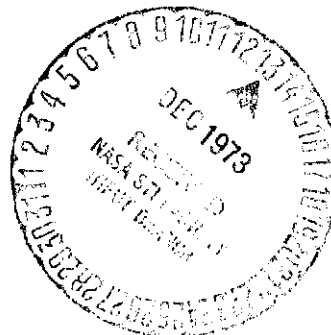

DESIGN AND EVALUATION OF CONTROLS FOR DRIFT, VIDEO GAIN, AND COLOR BALANCE IN SPACEBORNE FACSIMILE CAMERAS

by Stephen J. Katzberg, W. Lane Kelly IV, Carroll W. Rowland, and Ernest E. Burcher

Langley Research Center
Hampton, Va. 23665

ORIGINAL CONTAINS
COLOR ILLUSTRATIONS

1. Report No. NASA TN D-7333	2. Government Accession No.	3. Recipient's Catalog No.	
4. Title and Subtitle DESIGN AND EVALUATION OF CONTROLS FOR DRIFT, VIDEO GAIN, AND COLOR BALANCE IN SPACEBORNE FACSIMILE CAMERAS		5. Report Date December 1973	6. Performing Organization Code
		8. Performing Organization Report No. L-8845	10. Work Unit No. 502-03-52-04
7. Author(s) Stephen J. Katzberg, W. Lane Kelly IV, Carroll W. Rowland, and Ernest E. Burcher		11. Contract or Grant No.	13. Type of Report and Period Covered Technical Note
9. Performing Organization Name and Address NASA Langley Research Center Hampton, Va. 23665		14. Sponsoring Agency Code	
		12. Sponsoring Agency Name and Address National Aeronautics and Space Administration Washington, D.C. 20546	
15. Supplementary Notes			
16. Abstract The facsimile camera is an optical-mechanical scanning device which has become an attractive candidate as an imaging system for planetary landers and rovers. This paper presents electronic techniques which permit the acquisition and reconstruction of high-quality images with this device, even under varying lighting conditions. These techniques include a control for low-frequency noise and drift, an automatic gain control, a pulse-duration light-modulation scheme, and a relative spectral gain control. Taken together, these techniques allow the reconstruction of radiometrically accurate and properly balanced color images from facsimile camera video data. These techniques have been incorporated into a facsimile camera and reproduction system, and experimental results are presented for each technique and for the complete system.			
17. Key Words (Suggested by Author(s)) Facsimile camera Video processing Optical-mechanical scanner Automatic gain control		18. Distribution Statement Unclassified - Unlimited	
19. Security Classif. (of this report) Unclassified	20. Security Classif. (of this page) Unclassified	21. No. of Pages 31	22. Price* Domestic, \$3.00 Foreign, \$5.50

* For sale by the National Technical Information Service, Springfield, Virginia 22151

CONTENTS

	Page
SUMMARY	1
INTRODUCTION	1
SYMBOLS	2
VIDEO ACQUISITION ELECTRONICS	4
Preamplifier-Drift Control	5
Automatic Gain Control	7
VIDEO RECONSTRUCTION ELECTRONICS	9
Pulse-Duration Modulation	9
Relative Spectral Gain Control	11
CONCLUDING REMARKS	12
APPENDIX - DRIFT-CONTROL ANALYSIS	13
REFERENCES	16
FIGURES	17

DESIGN AND EVALUATION OF CONTROLS FOR
DRIFT, VIDEO GAIN, AND COLOR BALANCE
IN SPACEBORNE FACSIMILE CAMERAS

By Stephen J. Katzberg, W. Lane Kelly IV,
Carroll W. Rowland, and Ernest E. Burcher
Langley Research Center

SUMMARY

The facsimile camera is an optical-mechanical scanning device which has become an attractive candidate as an imaging system for planetary landers and rovers. This paper presents electronic techniques which permit the acquisition and reconstruction of high-quality images with this device, even under varying lighting conditions. These techniques include a control for low-frequency noise and drift, an automatic gain control, a pulse-duration light-modulation scheme, and a relative spectral gain control. Taken together, these techniques allow the reconstruction of radiometrically accurate and properly balanced color images from facsimile camera video data. These techniques have been incorporated into a facsimile camera and reproduction system, and experimental results are presented for each technique and for the complete system.

INTRODUCTION

The most frequently employed spaceborne imaging systems have been derivatives of electron-beam scanning devices and film cameras, while spaceborne radiometers and spectrometers have utilized *optical-mechanical scanning techniques*. However, some recent applications of optical-mechanical scanners have emphasized their role as imaging systems, then generally referred to as facsimile cameras, on the USSR spacecraft Luna 9 (ref. 1), Luna 13 (ref. 2), and Lunokhod (ref. 3). The facsimile camera has also been selected as the imaging device for the Viking '75 lander missions to Mars (ref. 4), and represents the first such use by the United States.

Early efforts concerned with adapting the facsimile camera to planetary lander missions, and in particular the Viking missions, have concentrated on basic optical performance characteristics and trade-offs (ref. 5) and on the line-scan imaging process (ref. 6). This paper is concerned with electronic techniques, both for generating a video

signal in the facsimile camera and for reconstructing a scene from this signal in a facsimile reproducer. Emphasis is directed toward three techniques: (1) the implementation of the direct-coupled (DC) mode of photodetector operation, (2) the incorporation of an automatic gain control, and (3) the reconstruction of color images from spectrally decomposed video data.

It has been shown in reference 7 that important advantages can be obtained for the facsimile camera by using the DC mode of photodetector operation. In this mode the photodetector and preamplifier must respond to zero frequency, subjecting the video signal to dc offsets, drift, and low-frequency noise. However, the unique operation of the facsimile camera allows these effects to be significantly reduced at the start (or end) of each line scan. The loss of radiation and the mechanical complexity required when the radiant signal is mechanically chopped for ac amplification can therefore be avoided, thus giving a twofold advantage. A technique for controlling drift and offset which permits the realization of the DC mode of operation is presented.

One problem faced when imaging from an exploring planetary lander is the uncertainty of surface radiance which will be encountered. In addition, surface radiance will vary with changes in illumination and viewing geometries and may also vary with meteorological activities, such as clouds and dust storms. Significant variations in surface albedo may also be encountered, especially by rovers. An automatic gain control is therefore presented which can minimize these effects without loss of the possibility of radiometric calibration.

Since the most important output of a facsimile camera system is the reconstructed image, electronic techniques which allow for linear film exposure as well as independent balancing of image color content are presented. These techniques cause the final quality to be limited by the film characteristics.

The above techniques have been implemented in a facsimile camera designed and built at the Langley Research Center, which will be referred to as the Langley facsimile camera system. This system was used to help establish design criteria that could be used on the Viking lander camera system being built on contract for the Viking '75 Project.

Finally, experimental results are presented for each of these techniques as well as for the complete system in the form of a color picture produced by the Langley facsimile camera system.

SYMBOLS

D, D_a	lens diameter, cm
$D(t)$	drift and offset component of video signal, V

D_0	drift amplitude, V
E, E_1, E_2	video signal, V
$F(t)$	functional dependence of atmospheric transmittance
f	frequency, Hz
f_0	drift-control cutoff frequency, Hz
K, K_a	constants
m	integer
$P_\lambda, P_{\lambda,a}$	radiant power, W
Re	real part
S_λ	source spectral irradiance, $\text{W}/\text{cm}^2\text{-}\mu\text{m}$
$S(t)$	sampling waveform
T	drift signal period, sec
t	time, sec
t_v	total mirror scan time per picture line, sec
$U_0(t)$	delta function
V_0	output signal, V
β	instantaneous field of view, rad
θ	drift signal phase angle, rad
$\phi_\lambda(\epsilon, l, g)$	illumination scattering function of surface
ρ_λ	reflectivity

τ_{λ}	atmospheric transmittance
$\tau_{\lambda,L}$	optical filter transmittance
λ	wavelength, μm

VIDEO ACQUISITION ELECTRONICS

The basic imaging process of the facsimile camera has been described elsewhere (see, e.g., ref. 6) and is reviewed here only briefly. Basically, the facsimile camera, as shown in figure 1, consists of a photodetector and scanning mechanism. Radiation from the scene is reflected by a scanning mirror, captured by an objective lens, and projected onto a plane which contains a photosensor aperture. As the mirror rotates, the imaged scene moves past the aperture, permitting the aperture to scan vertical strips. The photosensor converts the radiation falling on the aperture into an electrical signal. The camera is rotated after each line scan in azimuth so that successive line scans are contiguous and the entire scene of interest is scanned.

The principal function of the facsimile camera in a planetary lander configuration is to provide imagery data for the spatial characterization of the scene and, in addition, to provide radiometric data pertaining to elements in the scene. Factors which determine the image quality are angular resolution, depth of field, and signal-to-noise ratio. The angular resolution is set by the photosensor aperture size and its distance from the lens, while the depth of field is determined by the angular resolution and lens diameter. The signal-to-noise ratio, which limits radiometric accuracy and the minimum detectable change in scene contrast, is determined by the amount of radiation incident on the detector and the sensitivity of the photon detection technique.

The radiant signal can be spectrally divided for color imaging by alternately inserting filters into the optical path of a single detector (using, for example, a rotating filter wheel) or utilizing three detectors, each with an integrally mounted color filter. The time sequencing from one color channel to the next may occur either by frame, by line, or by picture element. In the case of the Viking lander camera, for example, three separate filter-detectors are placed along the mirror line-scan direction and electronically selected so that three vertical lines are scanned for each azimuth step.

The purpose of the following section is to present a drift-control circuit which allows the implementation of the DC mode of photodetector operation and an automatic-gain control circuit which permits imaging under a varying scene radiance. The role of these circuits in the video processing electronics is shown in figure 2, which illustrates the video acquisition electronics.

Preamplifier-Drift Control

The DC mode of detector operation in the facsimile camera has the advantage of high sensitivity while providing mechanical simplicity and, therefore, reliable operation (ref. 7). The often used ac amplification technique requires that the incoming radiation be mechanically chopped, thereby reducing the average incident radiant energy by, typically, 50 percent. However, the unique operation of the facsimile camera allows the detector output to be sampled in a dark condition, which in turn allows the implementation of the DC mode of amplification.

A block and a circuit diagram of the drift control system are shown in figure 3. As the mirror looks away from the scene and into the camera housing, the dc offsets, drift, and low-frequency $1/f$ noise, which are present at the preamplifier output, are sampled and stored. A dark-sample command, generated from an optical shaft encoder which monitors the vertical mirror position, is used to actuate a sample-and-hold circuit. This circuit charges a capacitor to the level present at the photodetector-preamplifier output and holds this level throughout the next scan line. The sample-and-hold output is then subtracted from the buffered preamplifier output to remove the dc offsets and low-frequency noise from the next vertical video scan line. Consequently, this circuit is in the passive state while video is acquired and does not influence the video signal except essentially to rezero the video electronics at the beginning of each scan line. In addition, the drift-control circuitry has no effect on noise fluctuations which occur after the sample-and-hold circuit is placed in the hold state (during video acquisition).

To evaluate the effect of the drift-control circuit, two questions must be considered: First, how accurately can the preamplifier output be sampled and subtracted? Second, what effect does this technique have on various frequencies of drift and $1/f$ noise?

The answer to the first question requires prior knowledge of the total time allowed to the dark sample, because this limits the accuracy of the sample-and-hold circuit. The circuit shown in figure 3(b) is typical of many sample-and-hold circuits. Its basic time and accuracy limitations are included in a specified acquisition time for a stated percent error from input to output. The Langley facsimile camera system has ratios of dark sample time to acquisition time of several hundred, allowing the error from the drift sample-and-hold circuit to be 60 dB down from drift amplitude. Note that the equivalent input noise voltage of the sample-and-hold circuit must be significantly lower than the detector-preamplifier noise voltage to prevent the introduction of additional noise into the video data.

The effect of the drift control on various frequencies of drift can be determined by evaluating the sampling process involved. The drift-control operation can be described basically as

$$E(t) = E_2(t) - E_1(t) \quad (1)$$

where $E_2(t)$ is the video data, including drift, and $E_1(t)$ is the output of the sample-and-hold circuit. The time dependence of these functions and the conversion to Fourier transform terms is shown in the appendix, where an expression is derived for the drift-control frequency response. In the appendix, for the purpose of analysis, a sinusoidal input drift function is assumed to be

$$D(t) = D_0 \cos(2\pi f_0 t + \theta) \quad (2)$$

and it is shown that the frequency which yields an error equal to the drift amplitude would be

$$f_0 = \frac{1}{4t_v} \quad (3)$$

where t_v is the interval between dark sampling and the completion of the succeeding line scan. The drift control acts as a high-pass filter and attenuates the noise at frequencies below f_0 .

This result can also be arrived at intuitively. Assuming a sinusoidally varying drift input and if the sampling period t_v is one-fourth of a complete drift period T , then it is possible to have the drift change by exactly its full amplitude during one control interval. Consequently, $t_v = \frac{T}{4} = \frac{1}{4f_0}$, or $f_0 = \frac{1}{4t_v}$, with lower frequencies unable to reach full amplitude during the sampling interval.

It should be pointed out that at frequencies higher than $\frac{1}{4t_v}$, the drift controller can actually double the offset errors. That is, the drift could change fast enough to get 180° out of phase with the last sample. This effect can be reduced by interposing a low-pass filter in the drift sampling link so that drift frequencies above $\frac{1}{4t_v}$ are heavily attenuated. Also, at very slow scan rates or when rapid thermal variations occur, some provision for more rapid dark referencing than once per line scan may be necessary.

The drift-control analysis developed in the appendix has been experimentally evaluated by means of the Langley facsimile camera system. Figure 4 shows the peak-to-peak response of the drift-control circuit to various sinusoidal simulated "drift" frequencies. Also plotted along with the experimental data is the theoretical curve, showing good agreement. These results indicate the effectiveness of drift-control circuitry in removing dc offsets and drift from the video signal. This drift control technique has been incorporated into the Viking lander camera design. Photon-detection sensitivities for the DC mode of operation have been investigated both analytically and experimentally in reference 7.

Automatic Gain Control

Because the facsimile camera scans a complete image frame with a single photodetector and because wide fields of view are possible within a single frame yielding long frame times, the facsimile camera data are vulnerable to changes in average scene radiance during the imaging process. An automatic gain control is described and analyzed here which can compensate for a varying scene radiance, allowing a selected average signal level, and hence selected film exposure in the facsimile reproducer, to be maintained throughout the complete image frame.

A circuit diagram of the automatic gain control is shown in figure 5. Basically, this control consists of a photodetector which has a very broad instantaneous field of view comparable with the size of the picture to be imaged and a voltage divider which divides the video signal by the automatic gain signal. If it is desired to compensate for only the scene irradiance, then the broad instantaneous field of view of the automatic-gain photodetector may be directed upward in the general direction of the radiation source. If it is desired to compensate for more localized variations in scene radiance also, then this field of view may be directed at the scene being imaged. This was done, for example, with the facsimile cameras on Luna 9 (ref. 8) and Lunokhod (ref. 9) in such a way that the instantaneous field of view of the automatic-gain photodetector monitored almost the complete scene being imaged. In either case, transmissions of the automatic gain control signal would allow reconstruction of absolute radiometric data. The signal could be transmitted during the inactive mirror scan time without loss of video data transmission time.

To analyze the operation of the automatic gain control, it is necessary to review some results concerning the method of radiation detection in the facsimile camera. (See ref. 5.) The amount of radiant power falling on the detector can be written as

$$P_{\lambda} = \frac{\pi}{16} \beta^2 D^2 \int_0^{\infty} S_{\lambda} \tau_{\lambda} \rho_{\lambda} \phi_{\lambda}(\epsilon, l, g) \tau_{\lambda, L} d\lambda \quad (4)$$

where β is the instantaneous field of view in radians, D is the objective lens diameter, S_{λ} represents the source illumination, τ_{λ} is atmospheric transmissivity, and ρ_{λ} and $\phi_{\lambda}(\epsilon, l, g)$ describe the reflectivity and illumination scattering function of the scene. In the case of the silicon solid-state detector, used in both the Langley facsimile camera system and the Viking lander camera, there is a linear response of detector current to incident radiant power, which allows a direct measurement of the integral in equation (4) by monitoring the detector output.

Let it now be assumed that the atmospheric transmittance τ_{λ} may vary with time as a result of meteorological activities, such as moving clouds. The radiant power falling on the imaging photodetector may then be expressed as

$$P_{\lambda}(t) = \frac{\pi}{16} \beta^2 D^2 \int_0^{\infty} S_{\lambda} \tau_{\lambda}(t) \rho_{\lambda} \phi_{\lambda}(\epsilon, l, g) \tau_{\lambda, L} d\lambda \quad (5)$$

Let it further be assumed that the broad instantaneous field of view of the automatic-gain photodetector monitors the complete scene being imaged. The radiant power falling on this detector may then be expressed as

$$P_{\lambda, a}(t) = \frac{\pi}{16} \beta_a^2 D_a^2 \int_0^{\infty} S_{\lambda} \tau_{\lambda}(t) \bar{\rho}_{\lambda} \bar{\phi}_{\lambda} \tau_{\lambda, L} d\lambda \quad (6)$$

where β_a is the instantaneous field of view, D_a is the lens diameter of the automatic gain control, and $\bar{\rho}_{\lambda}$ and $\bar{\phi}_{\lambda}$ represent the values of ρ_{λ} and $\phi_{\lambda}(\epsilon, l, g)$ averaged over the instantaneous field of view β_a .

As long as the spectral character of atmospheric transmissivity does not change appreciably, that is, $\tau_{\lambda}(t) \approx \tau_{\lambda} F(t)$, equations (5) and (6) can be written

$$P(t) = KF(t) \quad (7)$$

$$P_a(t) = K_a F(t) \quad (8)$$

where

$$K = \frac{\pi}{16} \beta^2 D^2 \int_0^{\infty} S_{\lambda} \tau_{\lambda} \rho_{\lambda} \phi_{\lambda}(\epsilon, l, g) \tau_{\lambda, L} d\lambda$$

and

$$K_a = \frac{\pi}{16} \beta_a^2 D_a^2 \int_0^{\infty} S_{\lambda} \tau_{\lambda} \bar{\rho}_{\lambda} \bar{\phi}_{\lambda} \tau_{\lambda, L} d\lambda$$

If the automatic-gain control detector is used as the divisor in the analog divider shown in figure 5 while the imaging detector provides the dividend input, the following output results, so long as the photodetectors have the same spectral sensitivities and linearities:

$$V_o = \frac{K}{K_a} \frac{F(t)}{F(t)} = \frac{K}{K_a} \quad (9)$$

Thus, the output voltage is now independent of time variations in scene irradiance, but still a function of variation in scene reflectance characteristics (ρ_λ and ϕ_λ).

The accuracy to which the image processing can be made independent of average illumination depends, of course, on the accuracy of the automatic-gain control circuit and the linearity of the two photodetectors, as well as the validity of the assumptions. Figure 6 presents some experimental results obtained with the Langley facsimile camera system. Shown is the apparent illumination of a picture element and the actual irradiance of the scene which includes this picture element.

Note that except at low divisor voltages there is very little variation in picture-element apparent signal level over a wide range of illumination signal level. In particular, for this system there is no more than a 15-percent change in video level for a 650-percent change in illumination. The less satisfactory operation at low illumination signal levels results from the inaccuracy of the analog divider used for this experiment.

VIDEO RECONSTRUCTION ELECTRONICS

Whereas the previous section was concerned with obtaining high-quality radiometric data with the facsimile camera, this section is concerned with recording these data on film as black-and-white as well as color images. The image reconstruction process may be divided into two parts: the transformation of video data into light energy for exposing the film, and the response of the film to reproduce faithfully the varying light energy to which it is exposed. This division is physically somewhat arbitrary since it is the combination of light generated from the video data and film response which determines image quality. However, since film sensitivities, linearity, and color fidelity are basically set by what is available from manufacturers, the video data must be tailored to match the film characteristics best. Specific film characteristics will not be considered here; however, the basic requirement for the conversion of video current to light to compensate for specific film characteristics in order to produce linear brightness or density variations on film is considered.

A pulse-duration modulation technique which overcomes nonlinearities and differences in nonlinearities among light sources is presented. In addition, a relative spectral gain control is presented for each color channel in order to provide proper relative color balance for color images. Taken together, these constitute the video processing electronics illustrated in figure 7.

Pulse-Duration Modulation

Several types of light sources which are capable of modulation are available. They range from high-intensity sources such as lasers through medium-intensity devices such

as glow modulators and solid-state sublasers down to diodes emitting relatively low-intensity light. Not all these devices cover the full spectral range required for color, and there is no absolute reason that only one device need be used for all colors. However, for simplicity it was deemed best to use only one type of source for the Langley facsimile camera system.

The glow modulator tube provides sufficient intensity for the direct recording of video data from the Langley facsimile camera system as well as the Viking lander camera. Consequently, it was chosen as a compromise between rapid film exposure possible with high-intensity lasers and ease of implementation. Glow modulator tubes have been employed for some time in facsimile recorders. They are basically plasma tubes that use a small electrode to concentrate the discharge, which, depending on the gas content, consists of the usual line structure and background characteristic of plasmas. Figure 8 shows the spectral content of the Sylvania 514 and 514C glow modulator tubes, and figure 9 shows the light output as a function of tube current in these tubes. As would be expected, the light output of the tubes, although monotonically increasing, is quite nonlinear.

Two basic techniques are generally used to provide a linear conversion of voltage to light for film exposure. One method, generally referred to as gamma correction, consists of multiplying the input voltage by a function which is the inverse of the nonlinear light-source characteristics. Implementation of gamma correction involves placing voltage-sensitive gain switches at appropriate intervals in the voltage feedback of an operational amplifier. This yields an approximation whose accuracy depends on the number of "breakpoints" utilized and can require complex circuitry.

The second method for linearizing film exposure and the one used in the Langley facsimile camera system, is based on a pulse-duration modulation technique. Since a film recording medium responds to the time-integrated intensity (energy) which it receives (film reciprocity effect is not considered here), it is readily apparent that if one maintains a constant level of light output (meaning constant tube current) but modulates the length of time that a particular picture element is exposed on the film surface, any light-source nonlinearities are overcome. To perform this operation, the video is sampled periodically at a rate sufficient to avoid interference with the highest video frequencies present, and the samples then modulate the width of constant-amplitude pulses. The pulses are applied to the vacuum tube which drives the glow modulator to the desired current for the duration of the pulse.

The circuitry for pulse-duration modulation is shown in figure 10. A triangular wave is generated at the video sampling frequency and is applied to one input on a high-speed voltage comparator. The video is applied to the other comparator input. At the beginning of a typical operation, the triangular wave starts up from zero and is less than the video

level. The comparator output is then in a high state, permitting tube conduction. When the triangular wave reaches the video level, the comparator switches low, inhibiting current through the tube. Consequently, film exposure is proportional to the magnitude of the video signal for each such sample.

The comparator output is directed to the vacuum tube for buffering purposes. Where precise specification of tube current is required, the tube cathode resistor is set to limit the current. Alternatively, the vacuum-tube saturation current may be used. In either case calibration is then performed on a tube for light output at some percent modulation and this is recorded for later use in adjusting gains for color balance.

Figure 11 shows the light output from glow tubes as a function of input current contrasted with the average light output obtained by pulse-width modulation plotted at the same average current (constant pulse height but variable duty cycle). The data were taken by driving a combination linear silicon photodetector and electronic filter with the output of a glow modulator. The filter represented the effect of optical degradation, or modulation transfer function, that exists in any imager using a finite-width writing spot. The improvement in linearity was apparent and led to the adoption of this method for the Langley facsimile camera system.

Relative Spectral Gain Control

The film reproducer of the Langley facsimile camera system utilizes the line sequential method of producing color images. Similarly, the camera of this system and also the Viking camera obtain color video data. In this technique first one color, then a second, and then the third is scanned on film. The reproducer then advances the film by the width of a scan and repeats the process. To reconstruct the data on film properly, the video electronics must be able to adjust for the differences in the spectral sensitivity of the imaging detector, the color-filter transmittance for both the camera and the reproducer, and finally the spectral response of the glow modulator tube and the film sensitivity. In the Langley facsimile camera system this is done as illustrated in figure 12, which shows that the glow tube modulator stage has a programmable gain capability. Synchronization pulses are derived from the camera at the rate of one pulse per line scan. These are counted in a divide by three counters, whose output is decoded into three lines. Each line drives a field-effect transistor (FET) switch controlling its own adjustable attenuator, and while any one attenuator can be held constant, any ratio of the other two to the first may be set.

Figure 13 presents a color picture obtained with the Langley facsimile camera system in which all the techniques described both for video acquisition and reconstruction were used. This picture is one of a series of the first color images obtained with a silicon photodetector in a facsimile camera, and was obtained to demonstrate the feasibility of this approach for the design of the Viking lander camera.

CONCLUDING REMARKS

This paper has presented electronic techniques which permit the processing of video data and reconstruction of high-quality images with facsimile cameras, even under adverse lighting conditions: (1) a drift control technique which can reduce the effects of drift and low-frequency noise in order to permit the implementation of a sensitive and mechanically simple photon detection technique; (2) an automatic-gain control technique which can compensate for wide, large-scale variations in scene illumination; (3) a pulse-duration modulation technique which can compensate for nonlinear reproducer light sources in order to obtain radiometrically accurate images; and (4) a relative spectral gain technique which can compensate for different spectral characteristics of each color channel of the facsimile camera, the reproducer, and the film in order to reconstruct properly balanced color images.

Circuits and experimental test data were presented for each technique. In addition, a color picture which required the use of all these techniques in a complete facsimile camera and reproducer system was presented. The color picture has a particular significance because it is one in a series of the first color pictures which were obtained to demonstrate the feasibility of obtaining color imagery with a silicon photodiode for the Viking lander camera design. This picture has the further significance of demonstrating the flexibility of the overall facsimile camera reconstruction system for properly correcting the inherent spectral characteristics of the silicon photodetector.

Langley Research Center,
National Aeronautics and Space Administration,
Hampton, Va., July 30, 1973.

APPENDIX

DRIFT-CONTROL ANALYSIS

The operation of the drift control consists of sampling the drift at the beginning of a picture-taking interval and subsequently subtracting this voltage level from the next video line. This process can be described as

$$E(t) = E_2(t) - E_1(t) \quad (A1)$$

where $E(t)$ is the drift-control output, $E_2(t)$ is the drift and video data, and $E_1(t)$ is the output of the sample-and-hold circuit. The sampling process of the sample-and-hold circuit may be described as follows:

$$E_1(t) = [D(t) U_0(t)] * S(t) \quad (A2)$$

where $D(t)$ is the drift signal, $U_0(t)$ is a delta function, $*$ denotes convolution, and $S(t)$ is a square-wave function. The function $S(t)$ may be described as

$$S(t) = 1 \quad (0 \leq t \leq t_v) \quad (A3)$$

$$S(t) = 0 \quad (\text{all other } t)$$

where t_v is the total mirror scan time per picture line.

The true drift which is superimposed on the video may be described as

$$E_2(t) = D(t) [U_0(t) * S(t)] \quad (A5)$$

The composite error is then

$$E(t) = D(t) [U_0(t) * S(t)] - [D(t) U_0(t)] * S(t) \quad (A6)$$

In the Fourier-transform domain, this may be written

$$\hat{E}(f) = \left\{ [D(0) \hat{U}_0(f)] * \hat{S}(f) \right\} - \left\{ [\hat{D}(f) * \hat{S}(f)] \right\} \quad (A7)$$

where f is frequency and the circumflexes indicate transform variables.

APPENDIX – Continued

Now let

$$D(t) = D_0 \cos (2\pi f_0 t + \theta) \quad (A8)$$

Then $\hat{E}(f)$ becomes

$$\hat{E}(f) = \frac{D_0}{2} \left[2U_0(f) \cos \theta - e^{i\theta} U(f - f_0) - e^{-i\theta} U_0(f + f_0) \right] * S(f) \quad (A9)$$

Taking inverse transforms gives

$$E(t) = D_0 S(t) \operatorname{Re} \left[e^{i\theta} (1 - e^{2\pi i f_0 t}) \right] \quad (A10)$$

or

$$E(t) = D_0 S(t) \left[\cos \theta - \cos (2\pi f_0 t + \theta) \right] \quad (A11)$$

The maximum of the bracketed quantity occurs when the following is satisfied:

$$\frac{dE(t)}{dt} = 0 = 2\pi f_0 (\cos \theta \sin 2\pi f_0 t - \sin \theta \cos 2\pi f_0 t) \quad (A12)$$

or

$$\tan 2\pi f_0 t = \tan \theta \quad (A13)$$

This is solved when

$$2\pi f_0 t = m\pi + \theta \quad (m = \text{Odd integer}) \quad (A14)$$

The maximum value for $E(t)$ would be just before $S(t) = 0$ (i.e., at $t = t_v$), which gives

$$2\pi f_0 t_v = m\pi + \theta \quad (A15)$$

Now θ may vary from $-\pi/2$ to $\pi/2$. Therefore, the first frequency which yields an error of maximum amplitude would be

$$f_0 = \frac{1}{4t_v} \quad (A16)$$

corresponding to $m = 1$, $\theta = -\pi/2$.

APPENDIX - Concluded

Furthermore, when the drift is very slow compared with the samples, then the product $2\pi f_0 t_V$ is small and equation (A11) can be expanded to give

$$E(t) \approx D_0 S(t) 2\pi f_0 t_V \sin \theta \quad (\text{A17})$$

$$E(t) \cong 2D_0 t_V S(t) f_0 \pi \quad (\text{A18})$$

which demonstrates that the drift controller acts somewhat like a high-pass filter. Thus the drift-control circuit has the twofold effect of eliminating drift and attenuating $1/f$ noise at low frequencies.

REFERENCES

1. Selivanov, A. S.; Govorov, V. N.; Titov, A. S.; and Chemodanov, V. P.: Lunar Station Television Camera. Contract NAS 7-100, Reilly Translations, 1968. (Available as NASA CR-97884.)
2. Cherkaasov, I. I.; Kemurdzhian, A. L.; et al.: First Panoramas of "Luna-13" - Determination of Density and Mechanical Strength of Lunar Surface Layer at the Landing Site of the Automatic Station "Luna-13". NASA CR-88874, 1967.
3. Brereton, R. G.; Burke, J. D.; Coryell, R. B.; and Jaffe, L. D.: Lunar Traverse Missions. JPL Quart. Tech. Rev., vol. 1, no. 1, Apr. 1971, pp. 125-137.
4. Mutch, T. A.; Binder, A. B.; Huck, F. O.; Levinthal, E. C.; Morris, E. C.; Sagan, Carl; and Young, A. T.: Imaging Experiment: The Viking Lander. Icarus, vol. 16, no. 1, Feb. 1972, pp. 92-110.
5. Huck, Friedrich O.; and Lambiotte, Jules J., Jr.: A Performance Analysis of the Optical-Mechanical Scanner as an Imaging System for Planetary Landers. NASA TN D-5552, 1969.
6. Katzberg, Stephen J.; Huck, Friedrich O.; and Wall, Stephen D.: An Investigation of Photosensor Aperture Shaping in Facsimile Cameras. NASA TN D-6882, 1972.
7. Kelly, W. Lane, IV; and Katzberg, Stephen J.: Investigation of Responsivity and Noise in a Direct-Coupled Photodetector-Preamplifier for Facsimile Cameras. NASA TN D-7338, 1973.
8. Anon.: The First Panoramic Views of the Lunar Surface. NASA TT F-393, 1966.
9. Selivanov, A. S.; Govorov, V. M.; Titov, A. S.; and Chemodanov, V. P.: Lunar Station Television Camera. JPRS 45374, U.S. Dep. Com., May 1968.

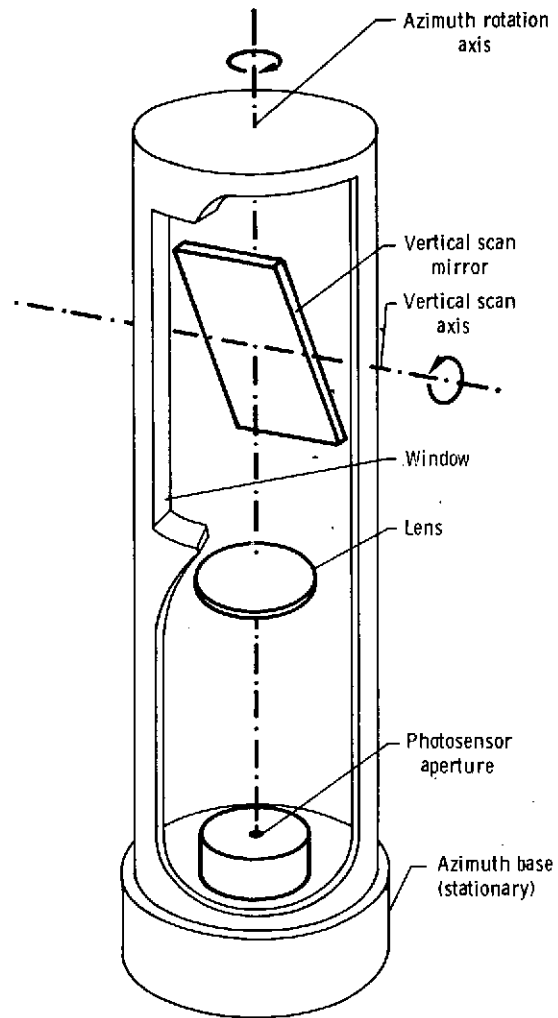

Figure 1.- Basic facsimile camera configuration.

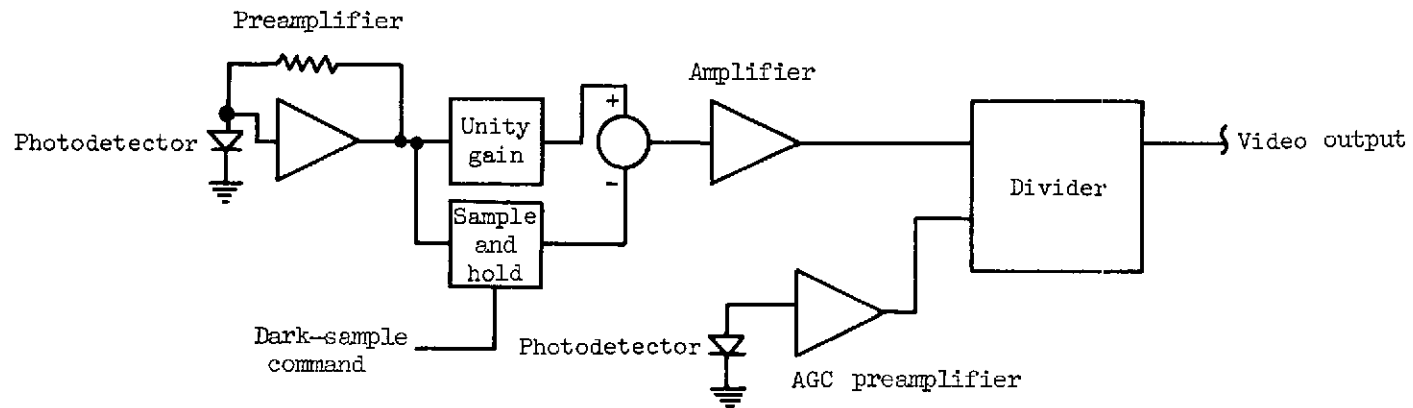
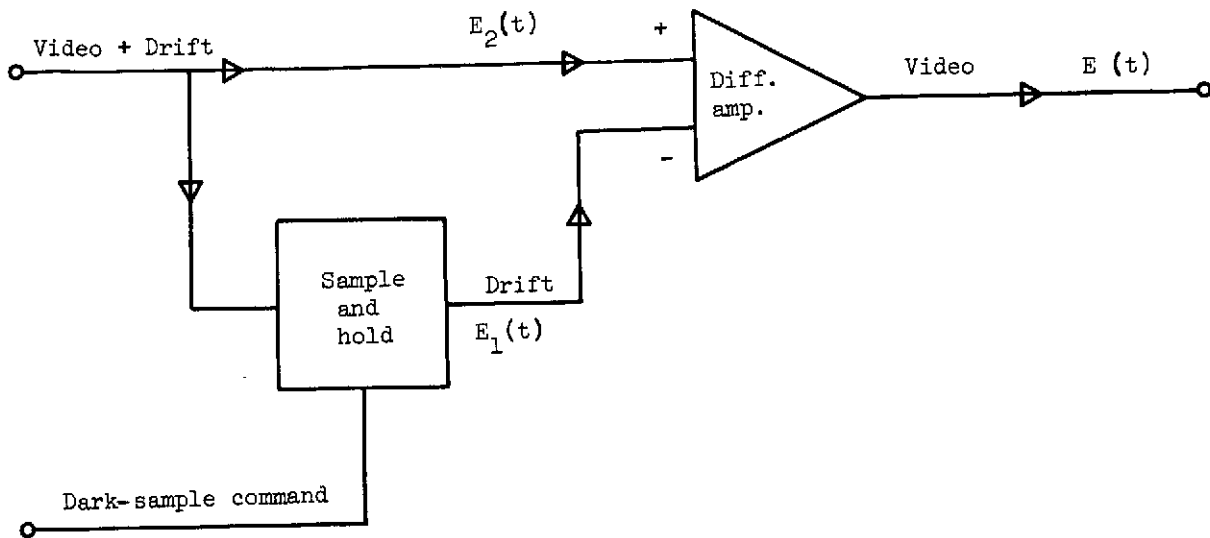
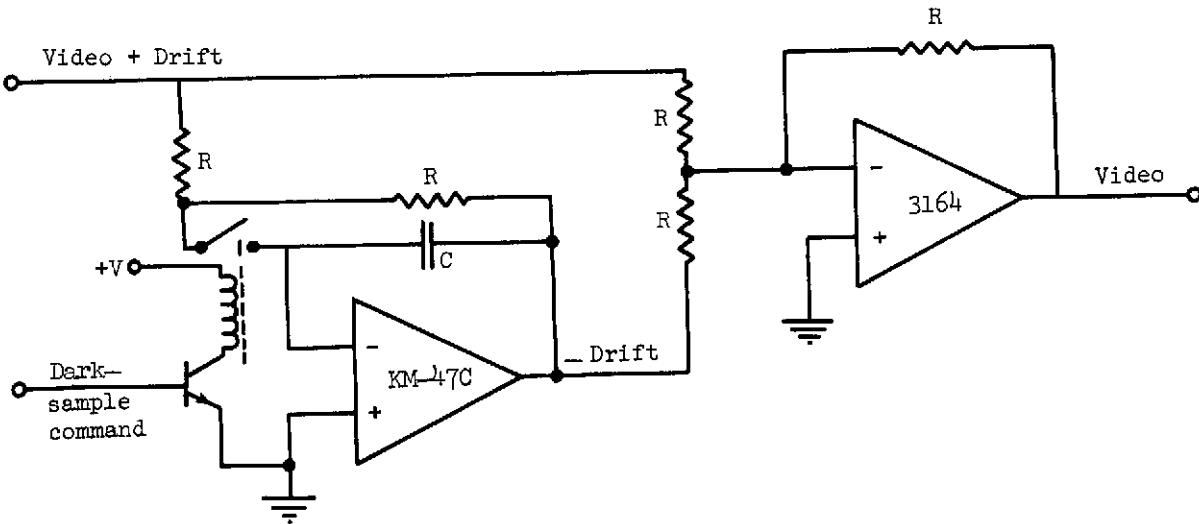

Figure 2.- Video acquisition electronics.



(a) Block diagram.



(b) Circuit diagram.

Figure 3.- Drift control system.

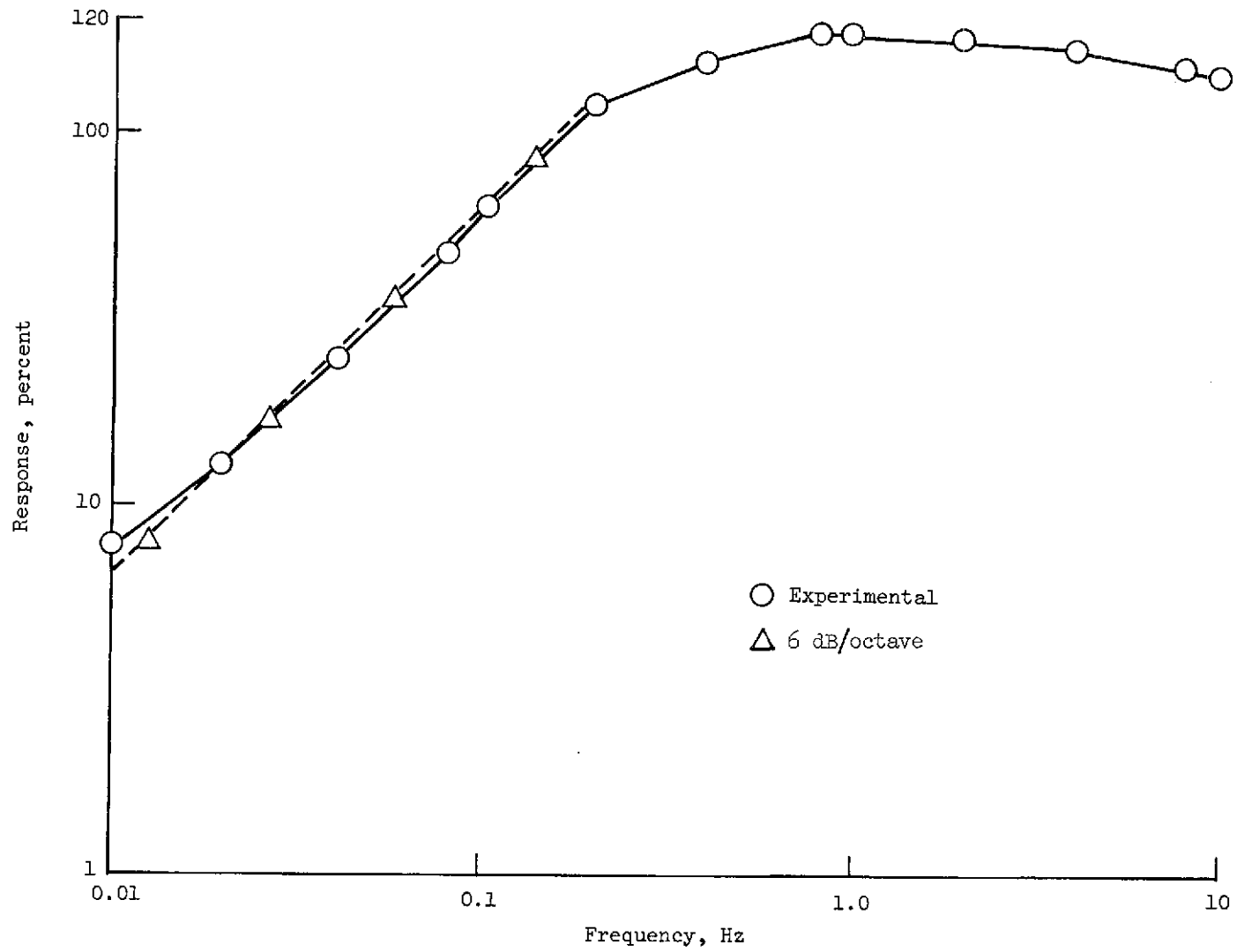

Figure 4.- Response of drift-control circuit to various input drift frequencies.

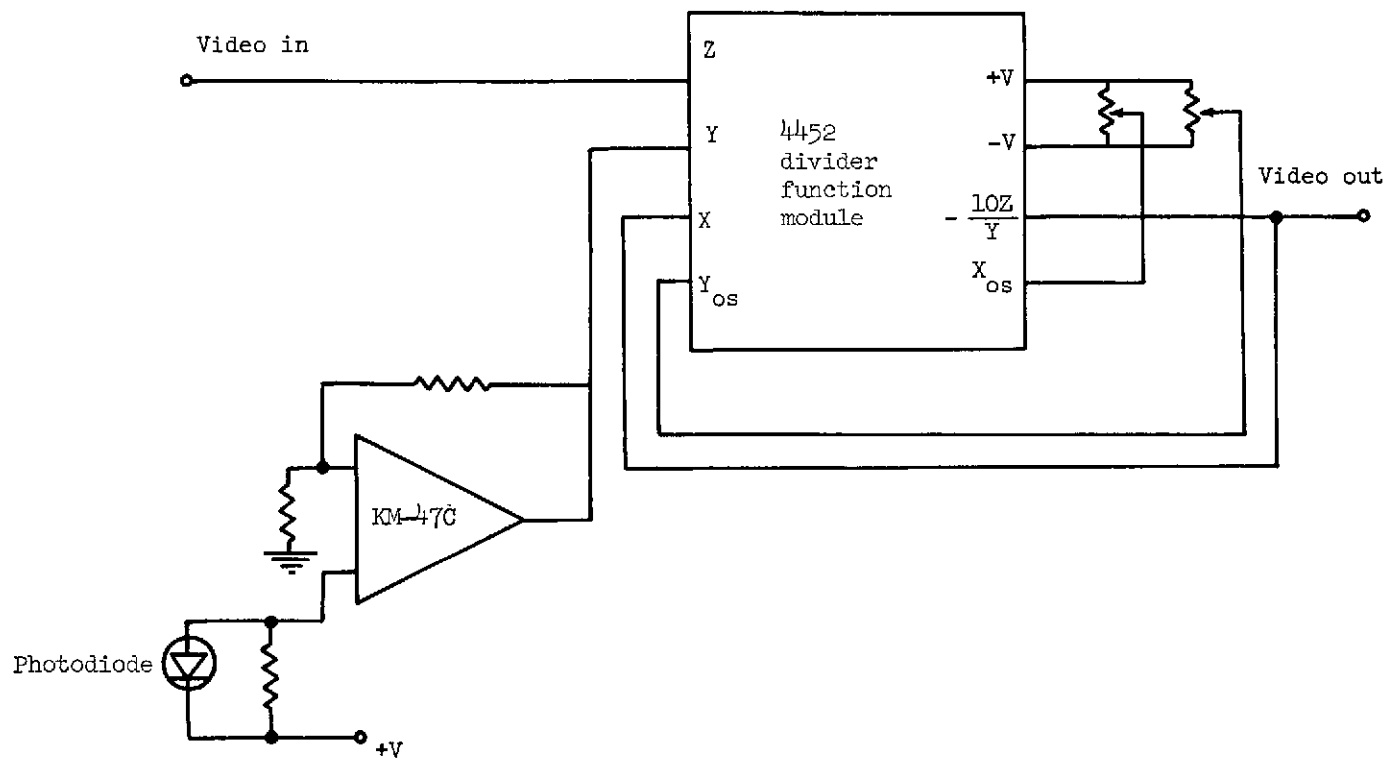
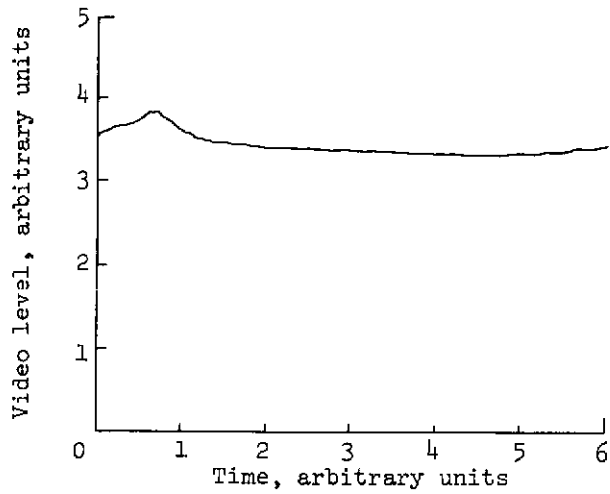
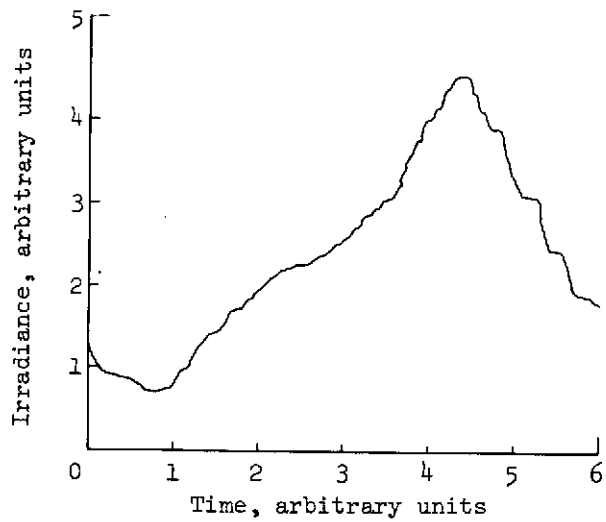

Figure 5.- Circuit diagram of automatic gain control.



(a) Apparent picture-element illumination.



(b) True picture-element illumination.

Figure 6.- Experimental results of the automatic gain control shown as variation in a picture-element video signal against variations in scene irradiance, with time as arbitrary parameter.

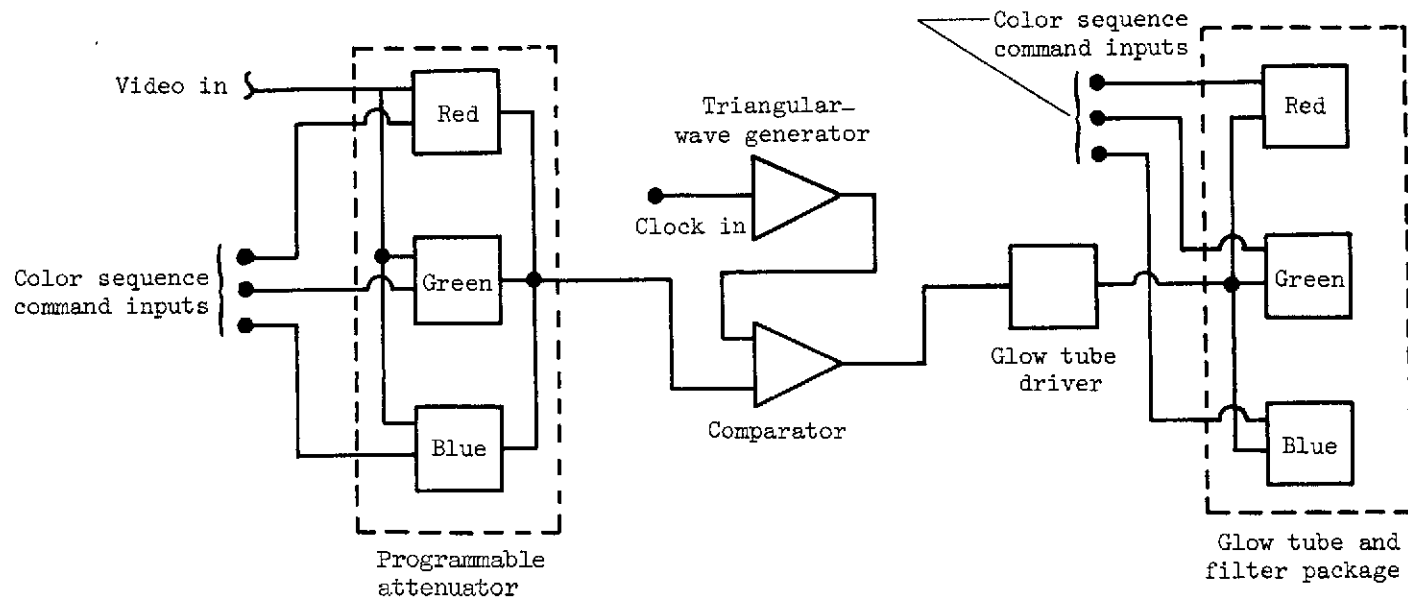

Figure 7.- Video reconstruction electronics.

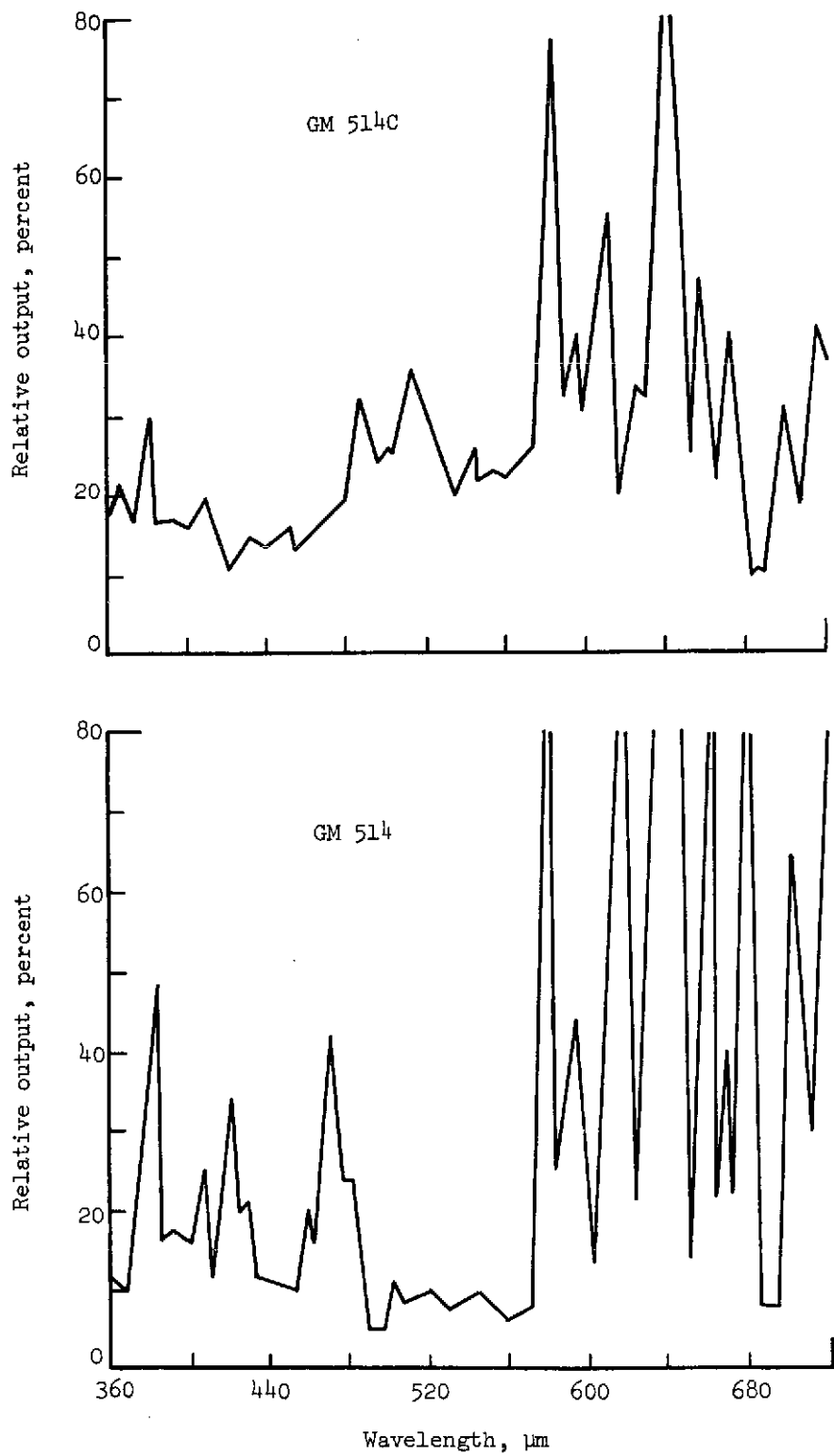

Figure 8.- Relative spectral content of glow modulators.

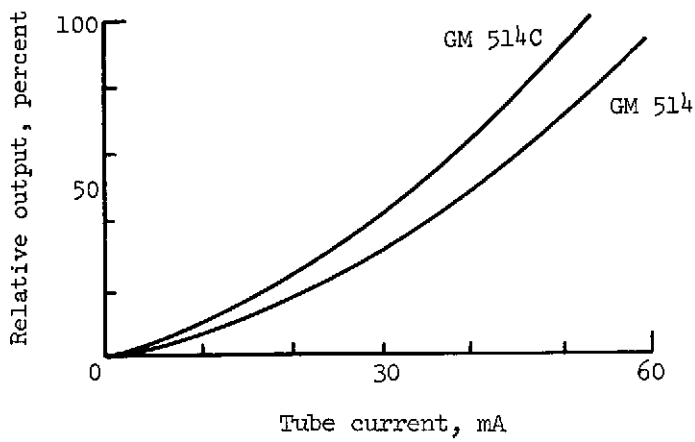

Figure 9.- Light output of glow modulator tubes as a function of tube current.

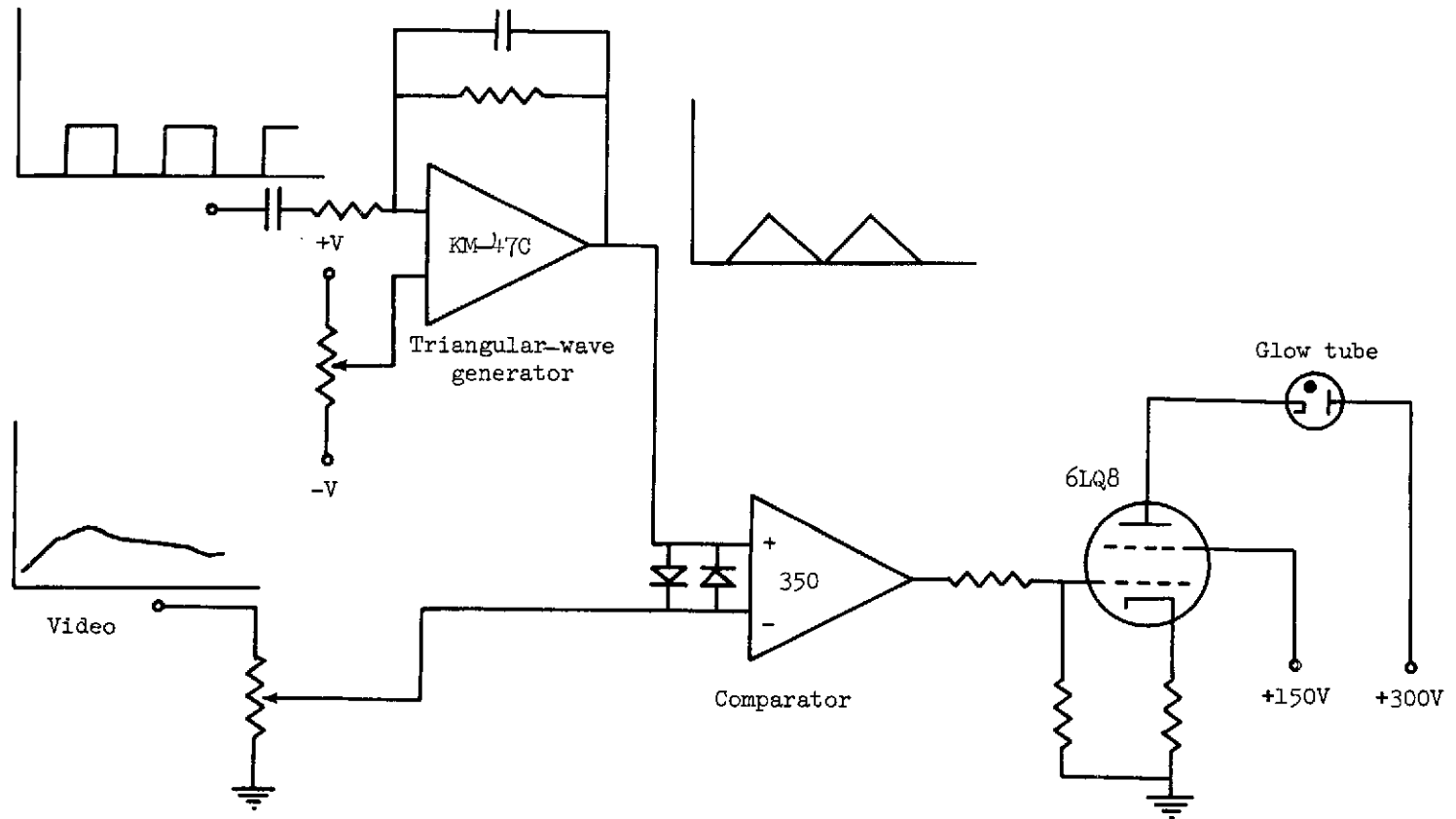

Figure 10.- Circuitry for pulse-duration modulation and glow-tube drive.

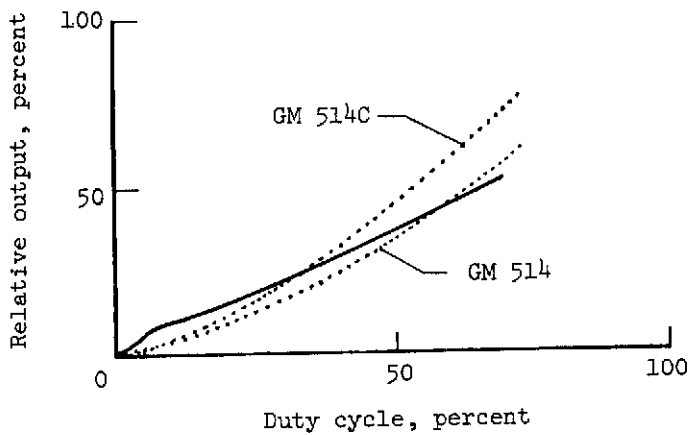

Figure 11.- Output of glow modulator tubes showing linearizing effect of pulse-duration modulation contrasted with direct drive. (Solid curve represents linearized output from either tube.)

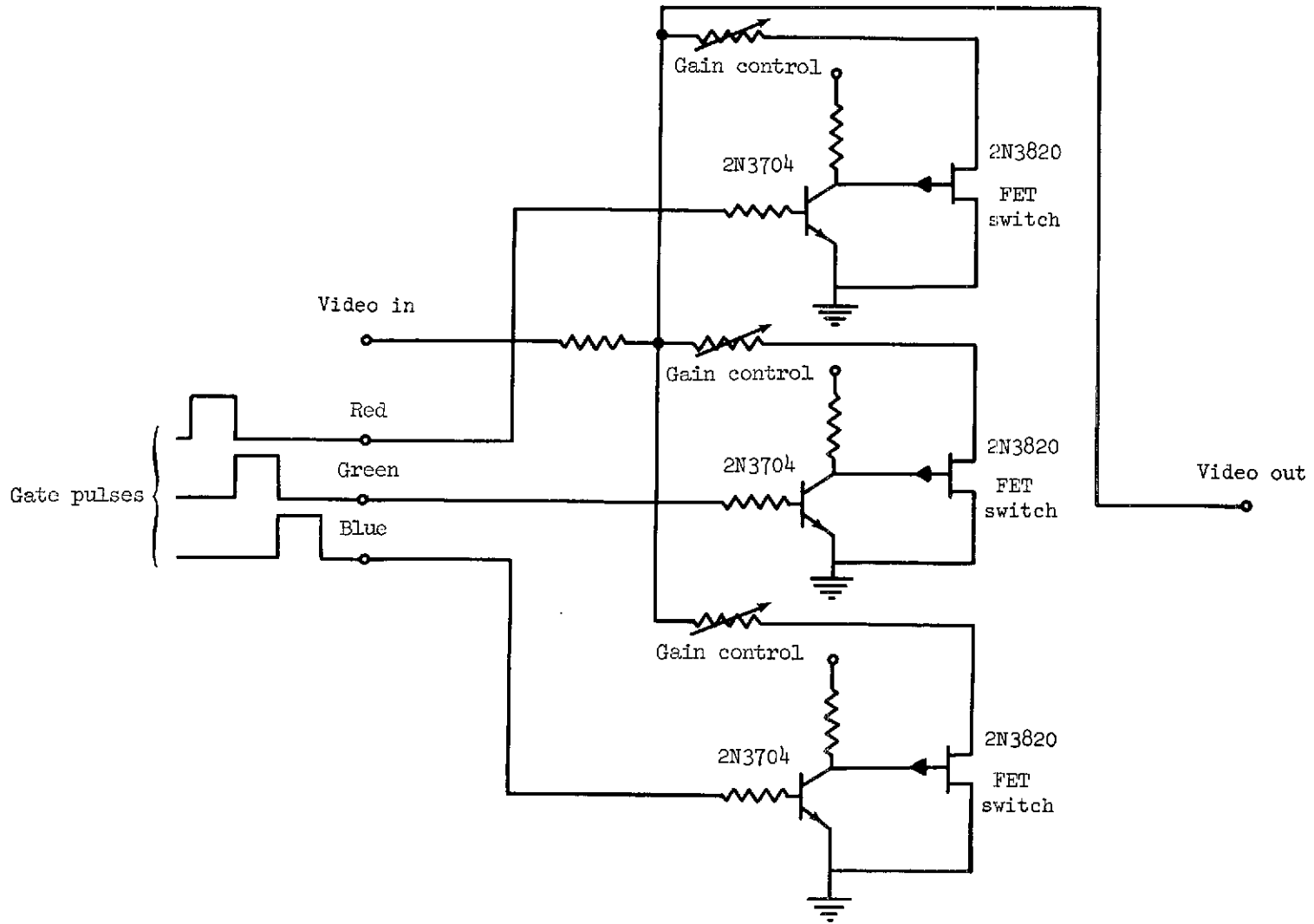

Figure 12.- Programmable attenuator with input command lines showing sequence of color commands.



Figure 13.- Color picture taken with the
Langley facsimile camera system.