

NASA CR-121255

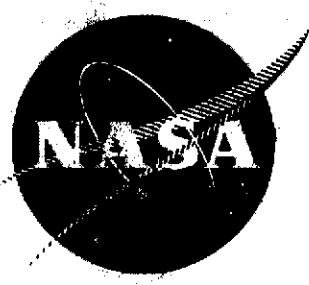

THE DESIGN OF A RESEARCH
WATER TABLE

by

R. L. Fike, R. B. Kinney, H. C. Perkins

AEROSPACE AND MECHANICAL
ENGINEERING DEPARTMENT

UNIVERSITY OF ARIZONA
TUCSON, ARIZONA

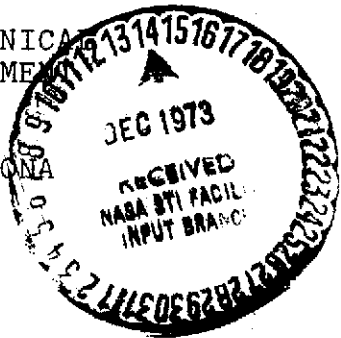

prepared for

NATIONAL AERONAUTICS AND SPACE ADMINISTRATION

NASA Lewis Research Center
Grant NGR 03-002-213

August, 1973



N74-12083
Unclas
23315
G3/12
(NASA-CR-121255) THE DESIGN OF A
RESEARCH WATER TABLE (Arizona Univ.,
Tucson.) 23 p HC \$3.25
CSCL 20D

1. Report No. NASA CR-121255	2. Government Accession No.	3. Recipient's Catalog No.	
4. Title and Subtitle THE DESIGN OF A RESEARCH WATER TABLE		5. Report Date August 1973	
		6. Performing Organization Code	
7. Author(s) R. L. Fike, R. B. Kinney, and H. C. Perkins		8. Performing Organization Report No.	
		10. Work Unit No.	
9. Performing Organization Name and Address Aerospace and Mechanical Engineering Department University of Arizona Tucson, Arizona 85721		11. Contract or Grant No. NGR 03-002-213	
		13. Type of Report and Period Covered Contractor Report	
12. Sponsoring Agency Name and Address National Aeronautics and Space Administration Washington, D. C. 20546		14. Sponsoring Agency Code	
		15. Supplementary Notes Project Manager, Albert F. Kascak, Nuclear Systems Division, NASA Lewis Research Center, Cleveland, Ohio.	
16. Abstract A complete design for a research water table is presented. Following a brief discussion of the analogy between water and compressible-gas flows (hydraulic analogy), the components of the water table and their function are described. The major design considerations are discussed, and the final design is presented.			
17. Key Words (Suggested by Author(s)) Water Table Hydraulic Analogy		18. Distribution Statement Unclassified - unlimited	
19. Security Classif. (of this report) Unclassified	20. Security Classif. (of this page) Unclassified	21. No. of Pages 22	22. Price* \$3.00

* For sale by the National Technical Information Service, Springfield, Virginia 22151

NASA CR-121255

THE DESIGN OF A RESEARCH
WATER TABLE

by

R. L. Fike, R. B. Kinney, H. C. Perkins

AEROSPACE AND MECHANICAL
ENGINEERING DEPARTMENT

UNIVERSITY OF ARIZONA
TUCSON, ARIZONA

prepared for

NATIONAL AERONAUTICS AND SPACE ADMINISTRATION

NASA Lewis Research Center
Grant NGR 03-002-213

August, 1973

i-a

FOREWORD

This, the first of four reports, describes the design of a water table for application to flow visualization studies for a rocket nozzle. The nozzle of interest has massive injection through the wall to provide thermal protection. Subsequent reports describe the experimental technique and present the analytical and empirical results. The work was performed under NASA Grant NGR 03-002-213 with Mr. Albert F. Kascak, Nuclear Systems Division, NASA Lewis Research Center as Technical Manager.

Preceding page blank

TABLE OF CONTENTS

SUMMARY.....1
INTRODUCTION.....2
THE HYDRAULIC ANALOGY.....3
THE WATER TABLE.....6
PRELIMINARY DESIGN CONSIDERATIONS.....8
DESIGN.....10
CONCLUDING REMARKS.....11
NOMENCLATURE.....12
REFERENCES.....13
APPENDIX A, THE ANALOGY.....17

Preceding page blank

SUMMARY

A complete design for a research water table is presented. Following a brief discussion of the analogy between water and compressible-gas flows (hydraulic analogy), the components of the water table and their function are described. The major design considerations are discussed, and the final design is presented.

INTRODUCTION

As early as 1911 (1) it was recognized that an analogy exists between the flow of water with a free surface and the two-dimensional flow of a compressible ideal gas. Fundamental to the analogy is the correspondence which exists between the velocity of propagation of a disturbance in the two streams. In the water flow, the velocity of a surface disturbance is proportional to the square root of water depth. In a compressible ideal gas, the velocity of a pressure disturbance (the sound speed) is proportional to the square root of the absolute temperature.

The water table has been used as a serious research tool only since about 1940 (2). Early works were directed toward the study of shock-waves, interference of wind tunnel walls on supersonic flow around models, and choking in subsonic wind tunnels. A recent review of the hydraulic analogy including the analogy for unsteady flow is given in Loh (3). The review includes much of the work of Preiswerk (2). The usefulness of the water table as a research tool lies in its versatility and ease of operation. In particular, quantitative measurements of local velocity and water height can be easily made. From these, the analogous Mach number can be obtained. Abrupt changes (corresponding to shock waves) can also be seen and easily photographed using simple lighting techniques.

This report is concerned with the design of a research water table to be used for flow visualization studies. Operational features of the basic table are discussed, and component specifications are presented. The flow experiments to be performed on the table are described in detail in Reference (4). Only a brief description is given here.

In particular, this water table was designed for studies of the effects of large injection on the momentum transfer in a porous or slotted wall nozzle. The results of this study are applicable to the design of rocket nozzles under such extreme conditions as proposed in the gas core nuclear rocket. Flow visualization studies have been done using the hydraulic analogy to obtain quantitative results to investigate how fluid injection effects the flow pattern and flow behavior in a converging-diverging nozzle. Results of these studies are given in References (4) and (5).

THE HYDRAULIC ANALOGY

The analogy between the frictionless flow of water with a free surface and the isentropic flow of an ideal gas is known as the hydraulic analogy. In its simplest form, the analogy is based on the following assumptions:

1. Steady state
2. One-dimensional flow
3. Frictionless fluid.

The theoretical basis for the hydraulic analogy is presented in detail in References (2) and (3) and in abbreviated form in Appendix A. Briefly, the foregoing assumptions, applied to the one-dimensional continuity, momentum and energy equations result in the equations shown in Table 1. Also shown are the analogous equations for one-dimensional gas flow.

Referring to the aforementioned equations, it is seen that there is a correspondence between the Froude and Mach numbers. It will be recalled that the velocity of a compressible gas is often expressed in terms of the Mach number, M . This quantity is the ratio of the local gas velocity to the local speed of sound. For a compressible ideal gas the speed of sound is proportional to the square root of the absolute temperature. The flow is termed subsonic, sonic, or supersonic for M less than, equal to, or greater than one. For one-dimensional supersonic flow in a nozzle, the Mach number is unity at the throat.

The analogous velocity ratio for open channel water flow is called the Froude number, F . It is the ratio of the local water velocity to the local speed of propagation of a surface disturbance. The latter quantity is proportional to the square root of the water depth. The water flow is termed subcritical, critical, or supercritical for F less than, equal to, or greater than unity. For supercritical one-dimensional water flow through nozzles, the Froude number is unity at the nozzle throat.

The correspondence between the variables in the equations of Table 1 are summarized in Table 2. From Table 2 it can be seen that the depth, H , of the water corresponds to density, temperature and the square root of the pressure. These are not simultaneously compatible since for isothermal gas flows the pressure and density must change in the same proportion. To circumvent this, the depth of the water can be used to find two of the three quantities, and the perfect gas law ($P = \rho RT$) the third. In many quantitative applications, the density and

pressure are found experimentally from the water depth, and the temperature is calculated from the perfect gas law.

The hydraulic analogy is based on idealized flow behavior. In its most general form, it is strictly applicable to inviscid two-dimensional flow. In actual water table flows, however, three-dimensional effects are present due to vertical acceleration caused by non-constant water depth. Also, frictional losses occur on the water table due to vorticity and boundary layer development. Of course, similar non-ideal behavior also occurs in real gas flows. Nevertheless, the idealization of isentropic flow is often justified. Finally, the steady-state analogy is valid only for a specific heat ratio of 2 while for air this ratio is 1.4. Approximate corrections can be used to extend the hydraulic results to gases with $\gamma \neq 2$. These are discussed in (6).

Table 1

COMPARISON OF EQUATIONS:

Compressible Gas:		Free Channel Liquid:
$\frac{dA}{A} + \frac{d\rho}{\rho} + \frac{dV}{V} = 0$	(Continuity)	$\frac{dB}{B} + \frac{dH}{H} + \frac{dV}{V} = 0$
$\frac{dT}{T} = -(\gamma-1)M^2 \frac{dV}{V}$	(Energy)	$\frac{dH}{H} = -F^2 \frac{dV}{V}$
$\frac{dA}{A} = (M^2-1) \frac{dV}{V}$	(Momentum)	$\frac{dB}{B} = (F^2-1) \frac{dV}{V}$
$c = \sqrt{g_c \gamma RT}$	(Definition of Disturbance Propagation Speed)	$c = \sqrt{gH}$
or		or
$\frac{dc}{c} = \frac{1}{2} \frac{dT}{T}$		$\frac{dc}{c} = \frac{1}{2} \frac{dH}{H}$
$M = \frac{V}{c}$	(Definition of Dimensionless Velocity)	$F = \frac{V}{c}$
or		or
$\frac{dV}{V} = \frac{dc}{c} + \frac{dM}{M}$		$\frac{dV}{V} = \frac{dc}{c} + \frac{dF}{F}$

Table 2

CORRESPONDENCE BETWEEN THE PARAMETERS OF TABLE 1:

Compressible Gas:	Free Channel Liquid:
P	H ²
V	V
A	B
ρ	H
T	H
c	c
M	F
γ	2

THE WATER TABLE

Matthews (7) has summarized the major considerations to be made in the construction of a water table. A design similar to the Langley eight-foot high-speed water tunnel was chosen for the present work.

A schematic of the water table is shown in Figure 1. The main components are: the overflow tank with the constant volume pump, starting section with adjustable weir, the table test section, the end tank with the propellor pump, the flow meter in the return line, and a means for tilting the water table (not shown).

The overflow tank, constant volume pump, and adjustable weir are used to control the flow and maintain steady state conditions. This will be explained more fully when the actual operation is discussed. The main flow passes through the test section which may be of variable cross section. If necessary, the water height can be measured with a point gage at various locations in the test section. The propeller pump in the end tank returns the flow to the starting section. The main flow is metered through a nozzle selected for its low head-loss characteristics. A pivot is useful for leveling the entire table structure. Also, tilting the table causes additional acceleration which enables higher velocities to be obtained for a given upstream head.

Steady-State Operation of the Water Table

The water table actually incorporates two flow circuits. These are the main test section flow and a controlling flow which is approximately 10% of the test section flow. The controlling flow, which maintains steady state condition, spills over the adjustable weir to a collecting tank. From this, it is returned to the starting section via a constant volume pump. When studies of the effects of wall injection on the main stream flow in a particular test section are made, a mass flow rate equal to the mass of injected fluid occurs over the weir. Fluid to be injected can then be extracted from the overflow tank. Under these conditions the second flow circuit is the fluid used for injection.

Under steady state conditions without injection in the test section, a constant volume of water is supplied to the starting section from the overflow tank. Thus, if the water depth in the starting section spontaneously increases, more water flows over the weir than is being passed through the pump. This results in a decreased depth in the starting section. If the head in the

starting section starts to drop, less water flows over the weir than through the pump, and the water level in the starting section increases. This flow compensation maintains very constant conditions upstream of the test section.

The starting section has a layer of aluminum honeycomb which straightens and damps out turbulence in the flow. The transition from the starting section to the table surface is rounded to reduce turbulence production.

PRELIMINARY DESIGN CONSIDERATION

The test section of the water table was made sufficiently large to house a converging-diverging nozzle for flow visualization studies. The construction of the nozzle plus the flow visualization techniques are discussed in (4).

For supercritical flow through a nozzle, three flow parameters are sufficient to completely specify the flow. For this design, the exit height, throat width, and exit Froude numbers were specified. From these, the flow rates and pumping requirements could be obtained.

To facilitate probing of the flow with a pitot tube, a minimum water depth of $1/2$ " was recommended. Since the minimum depth on the water table occurs at the nozzle exit, this fixed the exit height at $1/2$ ". The maximum throat width was selected to be 4". The maximum Froude number was set at 4.

The specification of the exit height and throat width is sufficient to allow the other flow conditions to be calculated for any specified exit Froude number. The exit height and Froude number determine the exit velocity. Assuming isoenergetic flow, the exit height and velocity set the total flow energy which in turn fixes the throat height. Since the Froude number is assumed to be 1 at the throat, this then specifies the throat velocity. From the throat height, width, and velocity, the flow rate through the test section is found. The equations that lead to these flow conditions are shown in Table 3. Table 4 lists the values of the various parameters for different values of F_e .

Table 3

GOVERNING EQUATIONS:

$$V_e = F_e \sqrt{gH_e}$$

$$E = H + V^2/2g$$

$$H_{th} = \frac{2}{3} E = \frac{2}{3} H_o$$

$$Q = V_{th} A_{th}$$

Table 4

VARIATION OF THE FLOW PARAMETERS WITH EXIT FROUDE NUMBER:

B_{th} , in.	4.0	4.0	4.0	4.0	4.0	4.0
H_e , in.	0.5	0.5	0.5	0.5	0.5	0.5
F_e	1.5	2.0	2.5	3.0	3.5	4.0
V_e , ft/sec	1.735	2.138	2.895	3.475	4.05	4.63
E , in. H_2O	1.06	1.51	2.06	2.74	3.58	4.51
H_{th} , in.	0.705	1.0	1.37	1.83	2.38	3.0
V_{th} , ft/sec	1.375	1.635	1.92	2.218	2.525	2.84
Q , cfm	1.61	2.72	4.25	6.77	10.0	14.15
B_e , in.	4.46	5.65	7.06	9.34	11.85	14.5

DESIGN

The basic water table is shown in Figures 2 and 3. A scaled drawing showing a side view of the table is given in Figure 4. All materials for the water table, which are in contact with the water, are aluminum, stainless steel or plexiglass. Aluminum is also used for most of the structural parts in order to reduce the weight of the table.

The size of the overflow tank (large rectangular tank in foreground of Figure 2) was determined by the flow rate and total volume requirements. As a minimum, the overflow tank must hold sufficient water to supply the difference in the water volumes required for minimum and maximum test section flow rates. The capacity of the overflow tank (more than 16 cubic feet) allows it to be used as a storage reservoir for the entire water supply of the system.

The starting section (Figure 1) runs the full width of the table. It has dimensions 4' x 1' x 32" and must be large enough to allow the honeycomb to damp out turbulence and to make the flow velocity very small. The 4 square-foot cross-sectional area reduces the flow velocity to less than 0.1 ft/sec at maximum flow conditions.

Clear plexiglass is used for the table surface to allow lighting from the bottom of the table while photographing experimental work. The table surface is supported by aluminum angles running the length of the table and attached to the large structural channels forming the sides. Intermediate support is provided by cylindrical spacers (Figure 3) resting on channels spanning the length of the table.

The propeller pump, which is actually an industrial mixer with variable speed control, is mounted on the end tank. This pump consists of a $1\frac{1}{2}$ hp variable speed DC motor with direct drive to a 4" propeller. The propeller and shaft are stainless steel to prevent corrosion. The pump runs at any speed from 90 to 1800 rpm and passes from 10 to 200 gpm.

The flow meter is located in the 4" return pipe made of Polyvinyl Chloride (PVC) plastic. The meter is plastic with a 1.526" bronze throat. It will provide deflections from 1.41" to 106" of water for flow rates from 12.2 to 106 gpm.

The constant volume pump is a progressive-cavity type. It has a stainless steel rotor with a rubber stator and will provide a constant volume flow from 1 to 11 gpm depending on its rotational speed.

CONCLUDING REMARKS

The design of a water table for application to flow visualization work has been presented. The components of the table and their function have been described. The flow visualization technique and experimental results are described in References (4) and (5).

NOMENCLATURE

A = flow area
B = width of water flow
c = velocity of disturbance propagation
E = total flow energy
F = Froude number, V/\sqrt{gH}
g = local acceleration of gravity
H = water height
M = Mach number, V/c
P = gas pressure
Q = volume flow rate
R = gas constant
T = absolute temperature
V = flow velocity
 γ = ratio of specific heats of gas
 ρ = density

Subscripts

e = nozzle exit
th = nozzle throat
o = upstream stagnation conditions

REFERENCES

- (1) Isaachsen, I., Innere Vorgänge in Strömenden Flüssigkeiten und Gasen, Z.V.D.I., Bd. 55, p. 428-431, 1911.
- (2) Preiswerk, Ernst, Application of the Methods of Gas Dynamics to Water Flows with Free Surfaces, NACA TM 934 and 935, 1940 (translated from German).
- (3) Loh, W. H. T., Theory of the Hydraulic Analogy for Steady and Unsteady Gas Dynamics, from Modern Developments in Gas Dynamics, Plenum Press, New York, 1969.
- (4) Cielak, Z.; Kinney, R. B.; and Perkins, H. C.; Flow Visualization Experiments in a Porous Nozzle, NASA Contractor Report CR-121256, August 1973.
- (5) Kinney, R. B.; Cielak, Z.; and Perkins, H. C.; Flow in a Porous Nozzle with Massive Wall Injection, NASA Contractor Report CR-134504, August 1973.
- (6) Adams, D. M., Application of the Hydraulic Analogy to Axisymmetric Nonideal Compressible Gas Systems, J. Spacecraft, 4, p. 359-363, 1967.
- (7) Matthews, C. W., The Design, Operation, and Uses of the Water Channel as an Instrument for Investigation of Compressible Flow Phenomena, NACA-TN-2008, January, 1950.

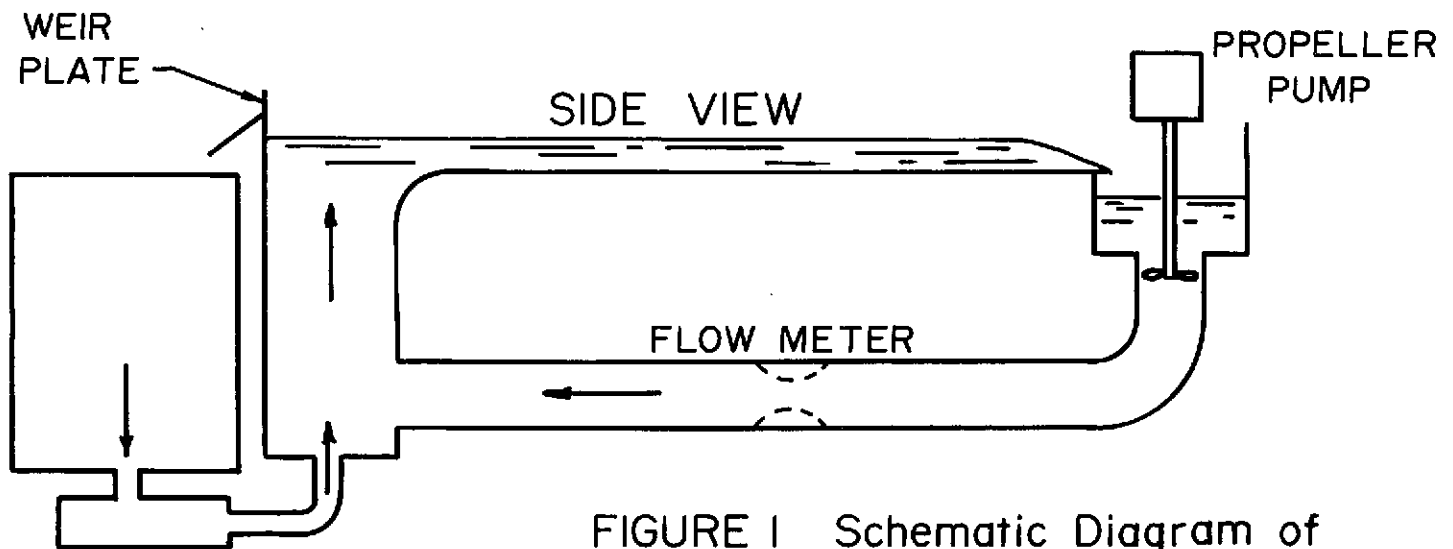
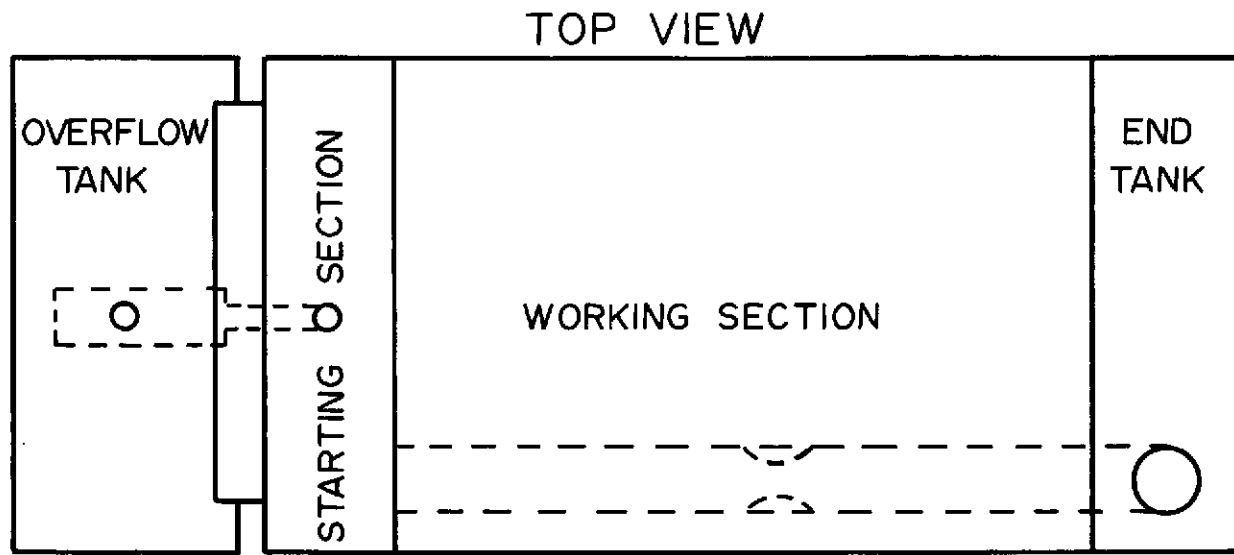

FIGURE 1 Schematic Diagram of Water Table

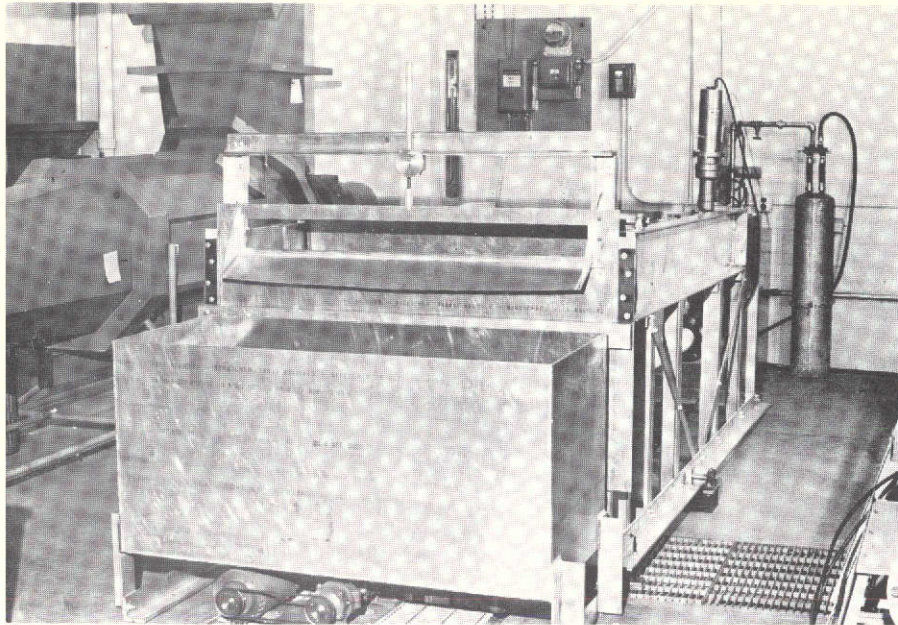
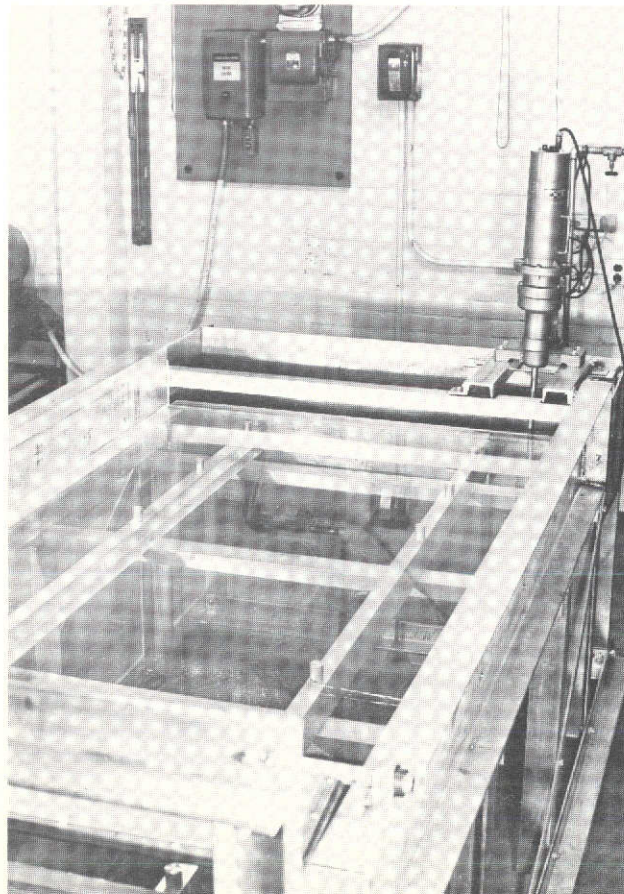

FIGURE 2 Overall View of Water Table



This page is reproduced at the back of the report by a different reproduction method to provide better detail.

- 15 -

FIGURE 3 Working Section of Water Table

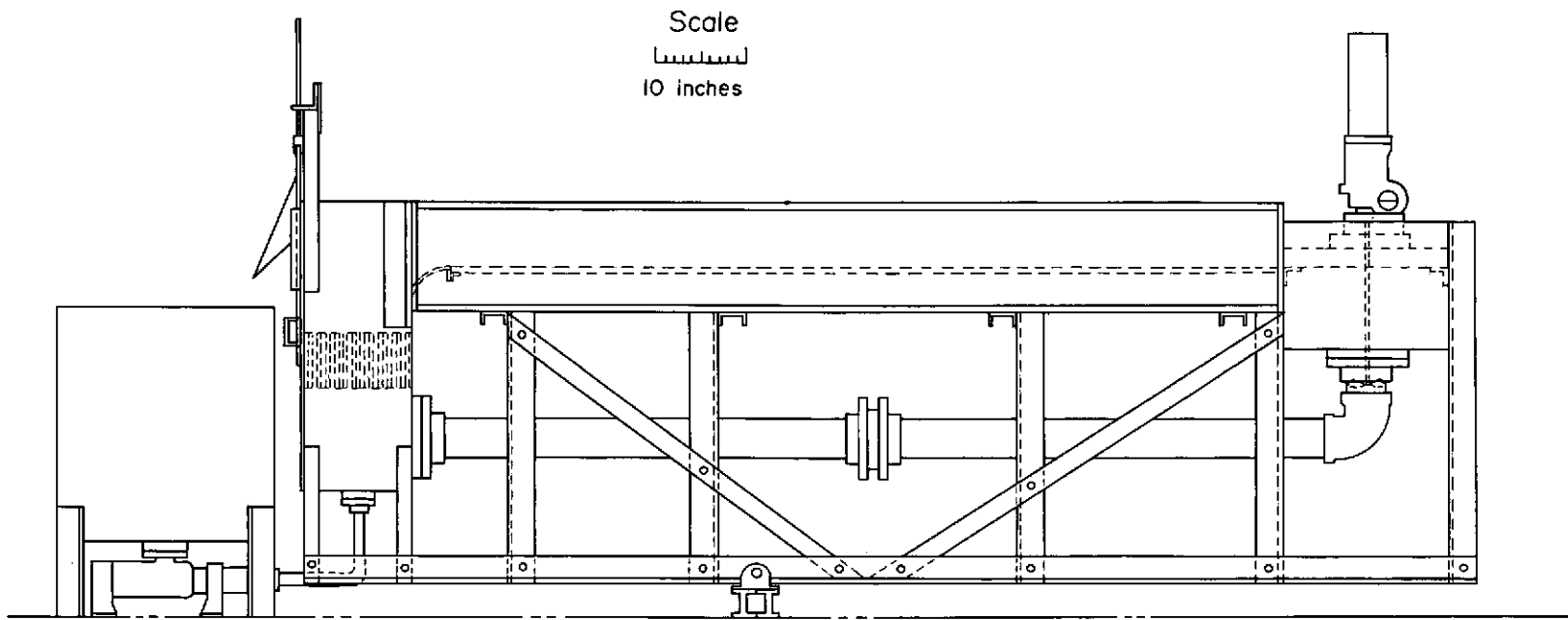
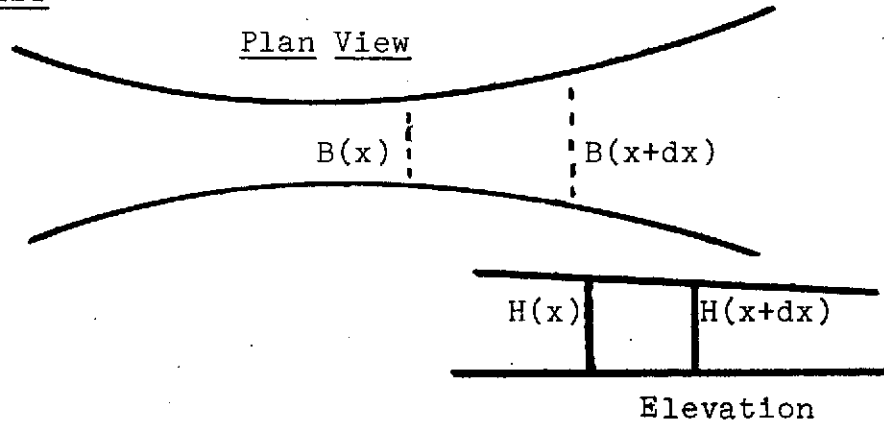

FIGURE 4 Scaled Side View of Water Table

-16-

APPENDIX A - THE ANALOGY

SYSTEM OF INTEREST



Continuity equation: $\rho AV = \text{constant}$

since $\rho = \text{constant}$,

$H \cdot B \cdot V = \text{constant}$,

So, $\frac{dH}{H} + \frac{dB}{B} + \frac{dV}{V} = 0.$ (A-1)

Momentum equation: Rate creation momentum = $\int F$

Summing the forces we find:

$$\int F_x = - \rho g B H dH$$

then substituting:

$(\rho AV)dV = - \rho g B H dH$
 or $\frac{dH}{H} = - \frac{dV}{V} \frac{V^2}{gH}$ (A-2)

since: Froude = $F = V/\sqrt{gH}$,

$$\frac{dH}{H} = - F^2 \frac{dV}{V}$$

using continuity:

$$\frac{dB}{B} = (F^2 - 1) \frac{dV}{V}$$
 (A-3)

The analogous compressible relation is:

$$\frac{dA}{A} = (M^2 - 1) \frac{dV}{V} \quad (A-4)$$

Thus the Froude number acts like the Mach number.

A development similar to the above shows that for a compressible gas:

$$\frac{dT}{T} = - (\gamma - 1) M^2 \frac{dV}{V}$$

Comparing to the equation (2) we see that for the hydraulic analogy H corresponds to T , and the ratio of specific heats $\gamma = 2$ for the gas flow which is comparable to the flow of the water.

THE FOLLOWING PAGES ARE DUPLICATES OF
ILLUSTRATIONS APPEARING ELSEWHERE IN THIS
REPORT. THEY HAVE BEEN REPRODUCED HERE BY
A DIFFERENT METHOD TO PROVIDE BETTER DETAIL