

2/24

NASA CR-132315

STUDY OF A QUASI-MICROSCOPE DESIGN FOR PLANETARY LANDERS

By Ouriel Giat and Earle B. Brown

(NASA-CR-132315) STUDY OF A QUASI-MICROSCOPE DESIGN FOR PLANETARY LANDERS (Perkin-Elmer Corp., Danbury, Conn.) 39 p HC \$4.00 CSCL 22B

N74-12502

G3/31 Unclas 22776



Prepared under Contract No. NAS1-11918 by THE PERKIN-ELMER CORPORATION Optical Technology Division Danbury, Connecticut

for

NATIONAL AERONAUTICS AND SPACE ADMINISTRATION

STUDY OF A QUASI-MICROSCOPE DESIGN FOR  
PLANETARY LANDERS

By Ouriel Giat and Earle B. Brown

Prepared under Contract No. NAS1-11918 by  
THE PERKIN-ELMER CORPORATION  
Optical Technology Division  
Danbury, Connecticut

for

NATIONAL AERONAUTICS AND SPACE ADMINISTRATION

i

TABLE OF CONTENTS

		Page
1.	INTRODUCTION .....	1
1.1	The Quasi-Microscope Concept.....	1
1.2	Preliminary Studies.....	3
2.	CANDIDATE CONFIGURATIONS.....	4
3.	PHOTOMETRIC ANALYSIS.....	5
4.	FINAL CONFIGURATIONS.....	10
4.1	Case I - Final Configuration Parameters.....	10
4.2	Case IV - Final Configuration Parameters.....	15
5.	CONCLUSIONS.....	20
6.	DESIRABLE EXTENSIONS OF WORK.....	20
APPENDIX A	PHOTOMETRIC ANALYSIS .....	25
APPENDIX B	GE NO. 1974 QUARTZLINE LAMP.....	33

PRECEDING PAGE BLANK NOT FILMED

## LIST OF ILLUSTRATIONS

		Page
1	Viking Lander facsimile camera .....	2
2	Candidate case I configuration .....	6
3	Candidate case II configuration .....	7
4	Candidate case III configuration .....	8
5	Candidate case IV configuration .....	9
6	Final case I configuration .....	11
7	Case I optical system prescription .....	12
8	Case I - H tan U curves at image plane .....	13
9	Case I - encircled energy in image plane .....	14
10	Case I - modulation transfer function (MTF) values .....	15
11	Final case IV configuration .....	16
12	Case IV - optical system prescription .....	17
13	Case IV - H tan U curves at image plane .....	18
14	Case IV - encircled energy in image plane .....	19
15	Case IV - MTF values .....	19
16	Potential modification to system (schematic) .....	22

STUDY OF A QUASI-MICROSCOPE DESIGN FOR  
PLANETARY LANDERS\*

By Ouriel Giat and Earle B. Brown  
The Perkin-Elmer Corporation  
Optical Technology Division

1. INTRODUCTION

1.1 The Quasi-Microscope Concept

One of the instruments being provided on the Viking Lander is a Facsimile Camera illustrated schematically in Figure 1. This instrument is installed on a vertical post and scans the Martian terrain, providing video signals which are transmitted to earth. It includes a 52.5 mm focal length, f/5.5 lens and a scanning mirror. The mirror sweeps out a vertical field, and the entire instrument is indexed about a vertical axis to provide a horizontal scan. The video output comprises the signals from a single detector at the focal plane. A set of several detectors provides flexibility of focus and spectral range; the control system makes a selection of a particular detector.

The Facsimile Camera, in its present form, provides for a minimum object distance of 1.9 meters, at which distance its resolution of 0.0007 radian (established by the azimuth step function of the scanning mirror) provides an object resolution of 1.33 millimeters.

It is desirable, especially for follow-on Viking missions subsequent to the first flight, to provide means for examining Martian terrain at resolutions considerably higher than that now provided in the Facsimile Camera. This desire has led to the concept of the Quasi-Microscope -- an attachment to be used in conjunction with the Facsimile Camera to convert it into a low-power microscope. The Viking Lander includes provision for acquiring samples of Martian soil, dumping these into a hopper and submitting them to a chemical test. Utilization of the Quasi-Microscope would involve presenting

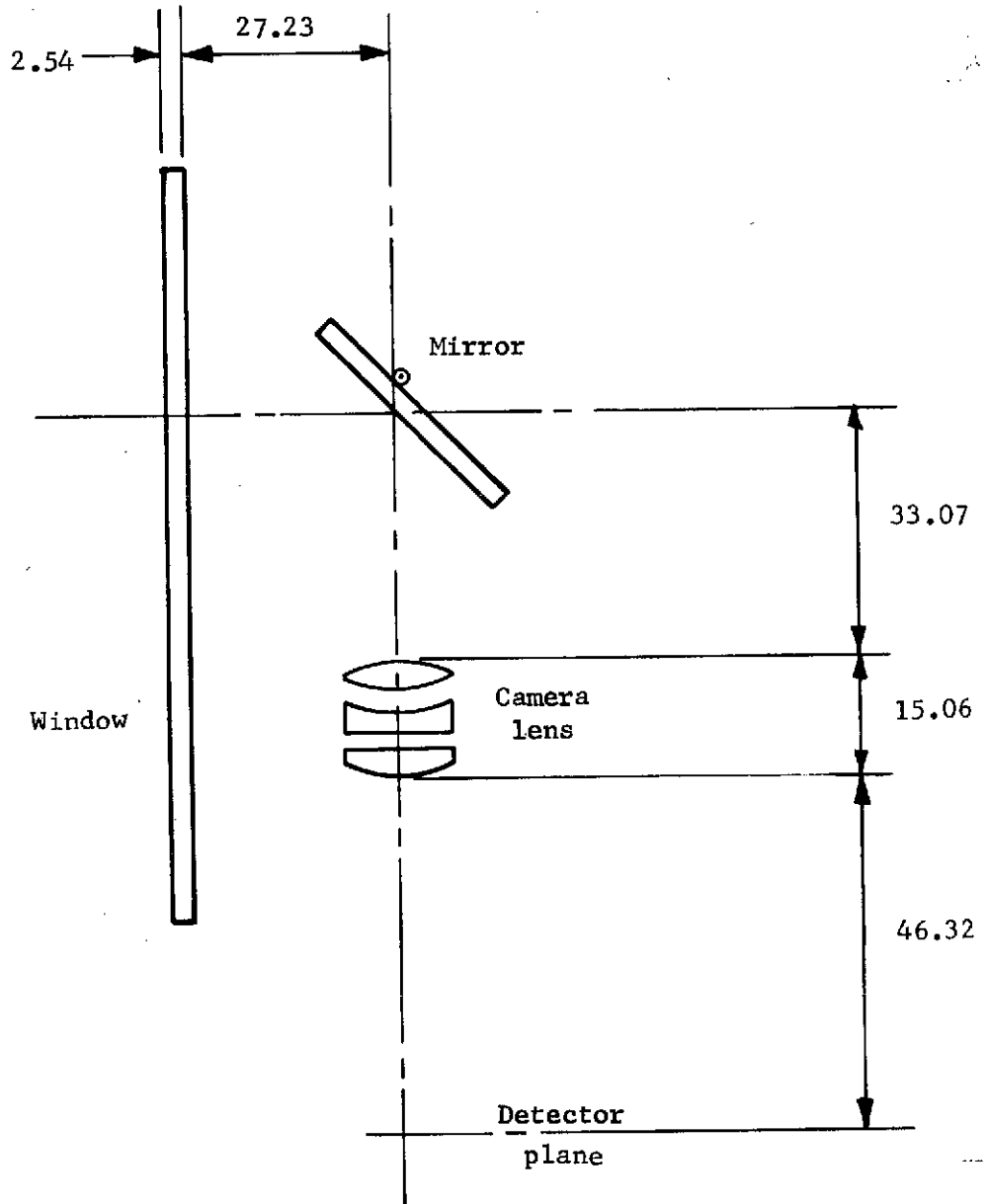

Figure 1. Viking Lander facsimile camera

these soil samples in front of the optical system -- with artificial illumination, if necessary -- and observing them through the Facsimile Camera in an alternate mode of operation.

The scope of work provided for under the subject contract was to consider alternate optical configurations for a Quasi-Microscope and to develop optical designs for a selected system or systems. Initial requirements included consideration of object resolutions in the range of 2 to 50 micrometers, an available field of view of the order of 500 pixels, and no significant modifications to the Facsimile Camera.

## 1.2 Preliminary Studies

Some introductory work had been performed at NASA-Langley\* which indicated that the Quasi-Microscope concept would be feasible -- at the outset of the subject contract, this work was reviewed and its results confirmed.

This first order analysis considered only a configuration in which an "auxiliary lens" was provided in the vicinity of the soil specimen and which produced a magnified virtual image -- either at infinity or at a large negative distance -- which was in turn scanned by the Facsimile Camera in its normal fashion. The inevitable result of this is that, since the auxiliary lens is necessarily located at a considerable distance from the Facsimile Camera, the available field of view is quite small, even if the auxiliary lens is made as large a diameter as practical.

It was, therefore, evident at the beginning that an arrangement in which the auxiliary lens forms a real image at a point not too far away from the Facsimile Camera will permit a substantially increased field of view. A field lens at this intermediate real image will image the aperture of the auxiliary lens directly into the aperture of the Facsimile Camera lens, thus eliminating vignetting over the field of view and reducing the illumination requirements

---

\*Huck, Sinclair and Burcher: First-Order Optical Analysis of a Quasi-Microscope for Planetary Landers, NASA Technical Note NASA TN D-7129, Feb. 1973.

substantially. The disadvantage of this configuration is that the location of the final image plane requires a modification of the existing Facsimile Camera. A potential solution to this problem is discussed in Section 6.

During the first phase of the contract effort, a first order exploration was made of both types of configuration over a wide range of overall distances, resolutions and auxiliary lens focal lengths and relative apertures. This resulted in the identification of the parameters for 89 alternate cases. At the same time, a brief examination of the applicable photometry was undertaken.

## 2. CANDIDATE CONFIGURATIONS

As a result of NASA-Langley's personnel reviewing the results of the preliminary studies discussed above, and consultations with them by Perkin-Elmer personnel, four candidate optical configurations were selected for a more detailed optical design study -- specifically for a preliminary optical design to establish their separate potential for achieving the resolution levels established by the Facsimile Camera parameters.

The parameters of these four systems are tabulated in Table 1. They include three systems which provide an intermediate real image in a field lens and one without a field lens, which provides a virtual image at infinity for examination by the Facsimile Camera. The four systems, as dimensioned for the separate cases, are illustrated in Figures 2 through 5.

Fundamentally, Case I is a "high magnification" system -- pixel size at object: 3.5 micrometers; Cases II and III are intermediate magnification, one utilizing an  $f/1$  auxiliary lens and the other an  $f/1.5$ ; and Case IV maintains the existing focal plane in the Facsimile Camera, at the cost of rather low resolution -- object pixel size: 42 micrometers -- which corresponds to an equivalent visual magnification of about 2x.

Preliminary optical design -- specifically third order analysis of existing lens arrangements scaled to the current requirements -- indicated that all the candidates would provide adequate optical performance.



TABLE 1  
PHOTOMETRIC PARAMETERS

Case	Pixel size at object (mm)	Magnification (a)	$f_o$ (b)	$E_{qm}$ (c)	$E_{qm}/E_s$
I	0.0035	14.8	1.50	0.443	15.83
II	0.0119	3.87	1.53	0.031	1.13
III	0.0167	2.67	2.22	0.031	1.13
IV	0.0420	1.10	6.30	0.043	1.54

- (a) Object to image
- (b) Aperture ratio of input bundle
- (c) Required irradiance (watt/cm<sup>2</sup>)

### 3. PHOTOMETRIC ANALYSIS

Although photometric analysis was not a part of the originally planned efforts, the feasibility of providing adequate illumination becomes a significant factor in determining the feasibility of at least one of the candidate systems (Case I); therefore, an analysis was made of the photometry of all four of the systems to provide essential data for making a final selection.

Appendix A, which reports on this photometric analysis, shows that irradiance at the Martian surface, within the spectral band of the silicon detectors used in the Facsimile Camera, is

$$E_s = 0.028 \text{ watt/cm}^2 \quad (1)$$

The photometric parameters of the four candidate cases are shown in Table 1. It is apparent that, for Cases II, III, and IV, it may be possible to design an object plane configuration that will provide illumination by direct sunlight. For Case I, provision of artificial illumination has been studied from a concept point of view, and it has been established that an

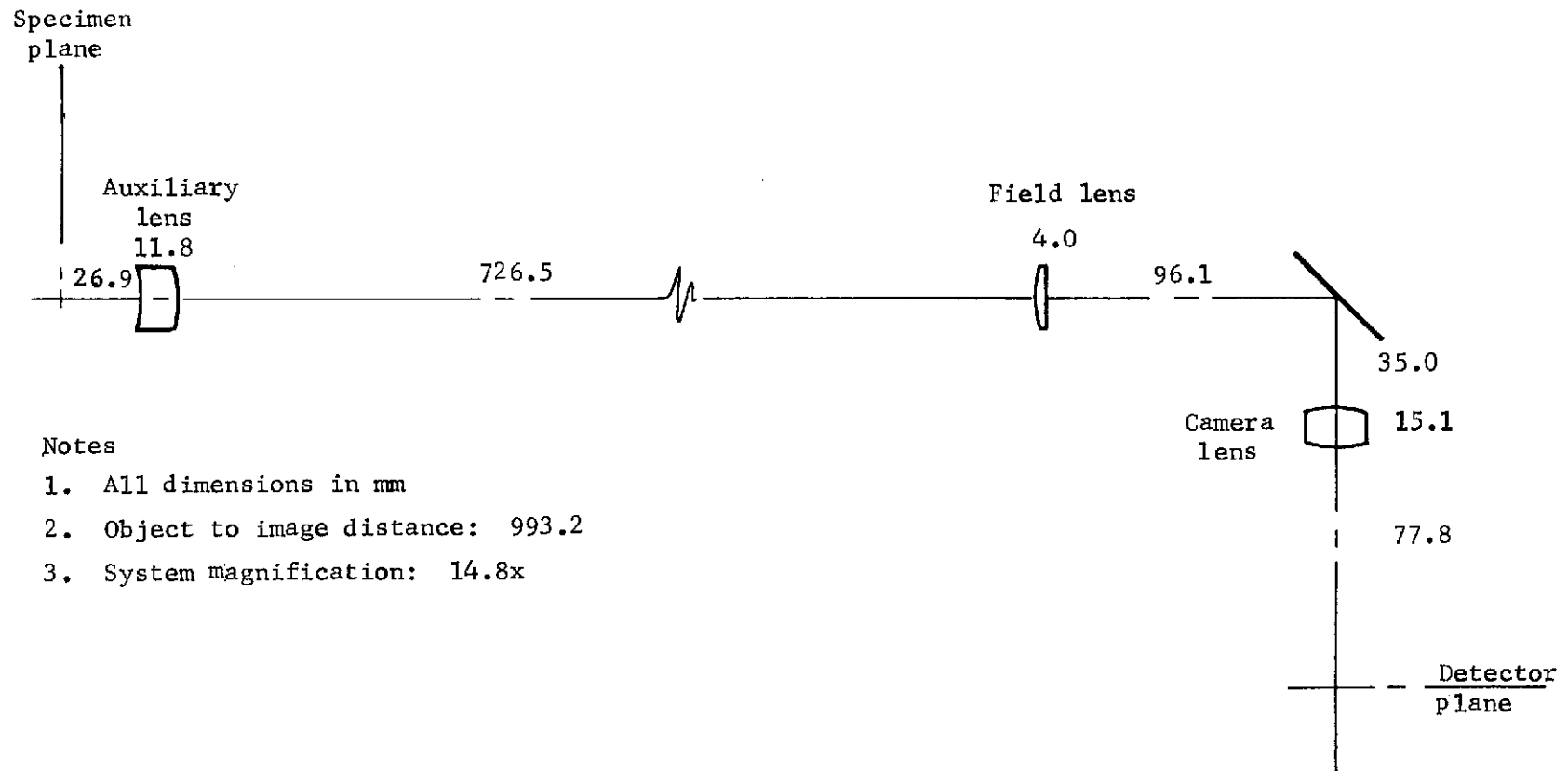

Figure 2. Candidate case I configuration

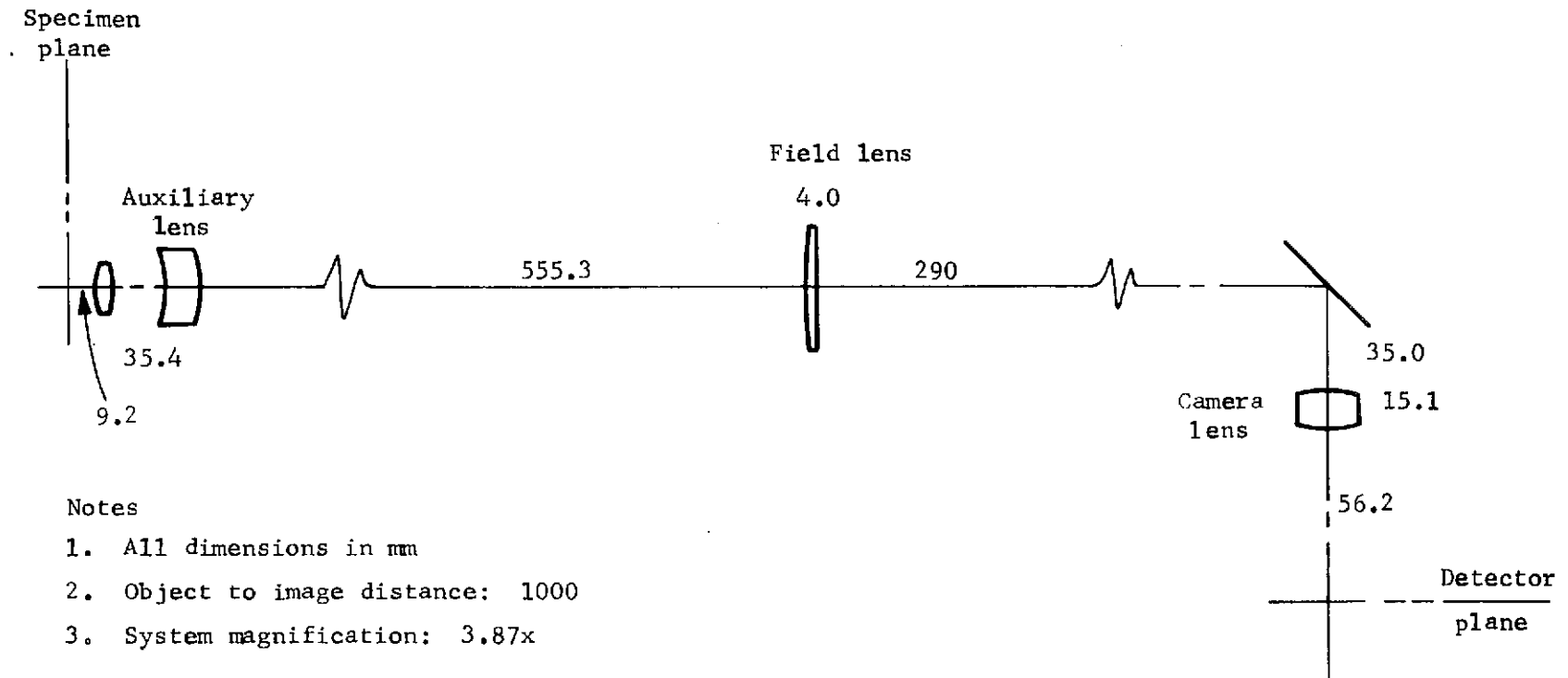

Figure 3. Candidate case II configuration

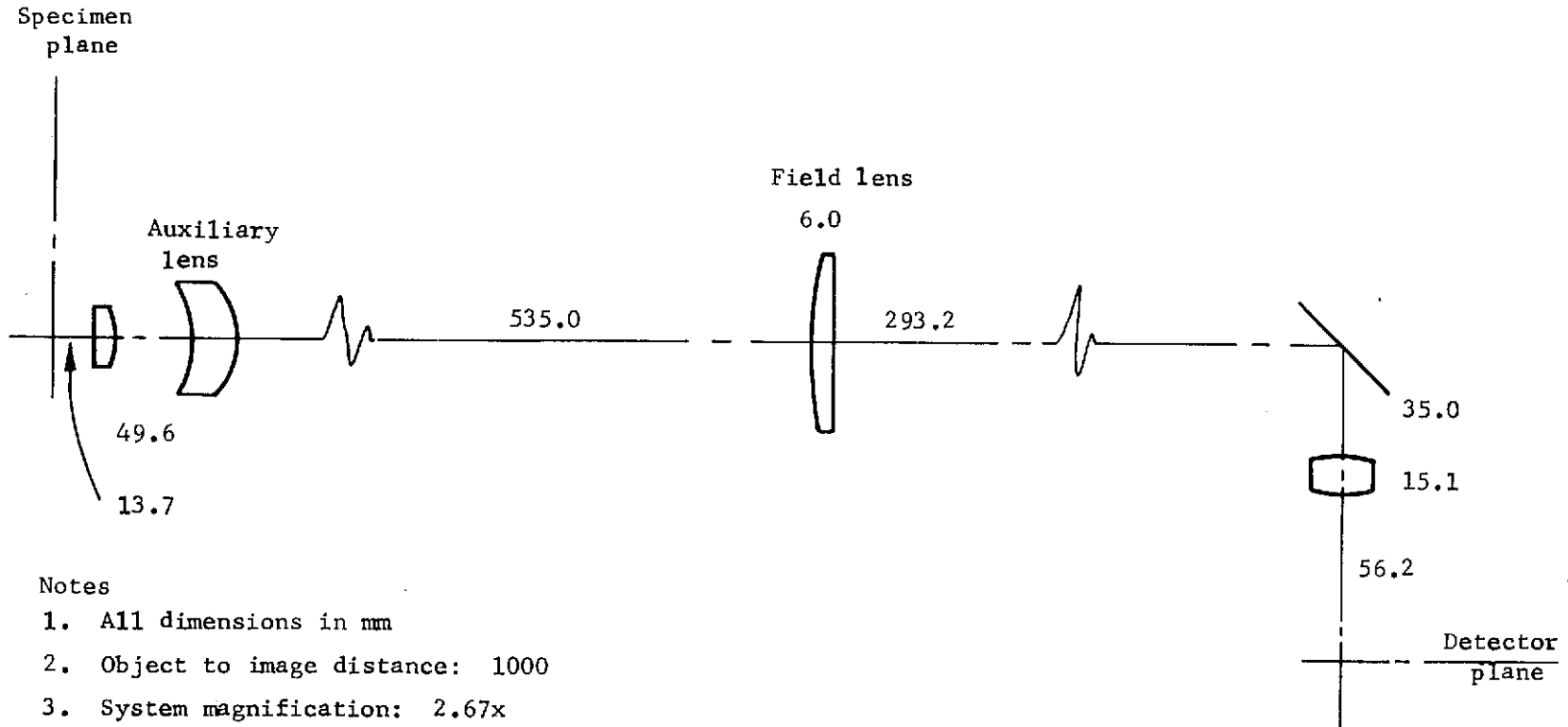
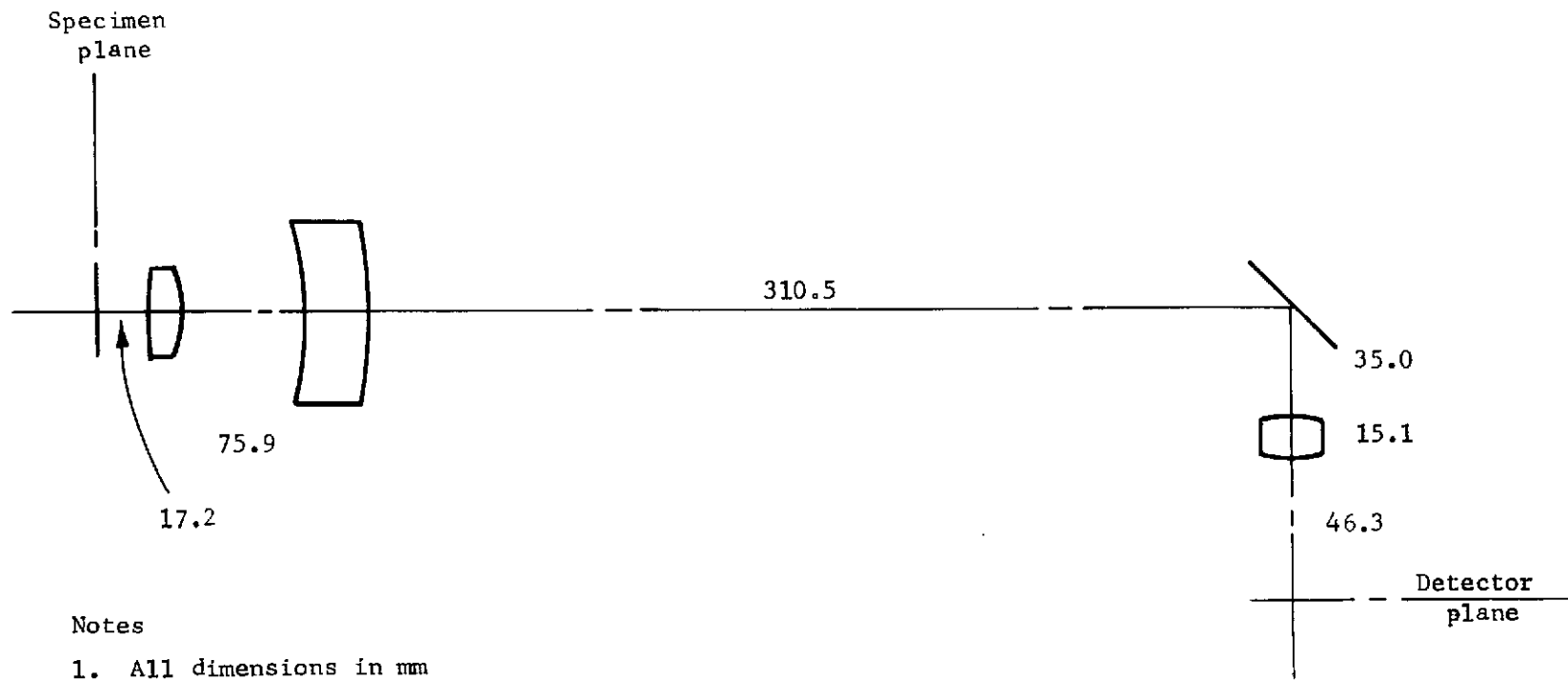

Figure 4. Candidate case III configuration



Notes

1. All dimensions in mm
2. Object to image distance: 500
3. System magnification:  $-1.1\times$

Figure 5. Candidate case IV configuration

available light source -- a G.E. Quartzline lamp, No. 1974, operating on 20 watts -- will provide more than twice the required illumination if used with an  $f/2$  illuminating optical system.

The photometric computations reported above have been based upon the assumption that an irradiance at the focal plane of the Facsimile Camera, equal to that which is received from the nominal Martian terrain illumination, will be adequate for operation in the Quasi-Microscope mode.

#### 4. FINAL CONFIGURATIONS

The preliminary design results discussed in Section 2 above were presented to NASA-Langley personnel on 22 March 1973 during an engineering visit by Perkin-Elmer personnel. The results and the trade-off factors between the four cases were discussed in depth, and two configurations were selected for the final optical design. These cases were Case I and Case IV.

##### 4.1 Case I - Final Configuration Parameters

A schematic of the final optical system configuration is shown in Figure 6. The object specimen is imaged by the auxiliary lens onto the field lens which, in turn, is imaged by the existing camera lens onto a Quasi-Microscope detector located  $80.87 - 46.32 = 34.55$  mm downlight from the existing detector array. The size of the object specimen represents 205.7 pixel elements and is limited by the maximum unvignetted field seen by the camera lens.

The optical system prescription is shown in Figure 7. The columns, successively, list the optical element surface number and form, radius, thickness, refractive index for 0.8, 0.75 and 0.95 micrometer wavelength and the glass code designation. At the bottom are given the system parameters for Gaussian imaging.

The aberration curves for the system are shown in Figure 8 for three field positions, i.e., on-axis ( $H=0$ ), 0.7 field ( $H=0.26$  mm) and at full field ( $H=0.375$  mm). For each field position, three aberration curves are shown for

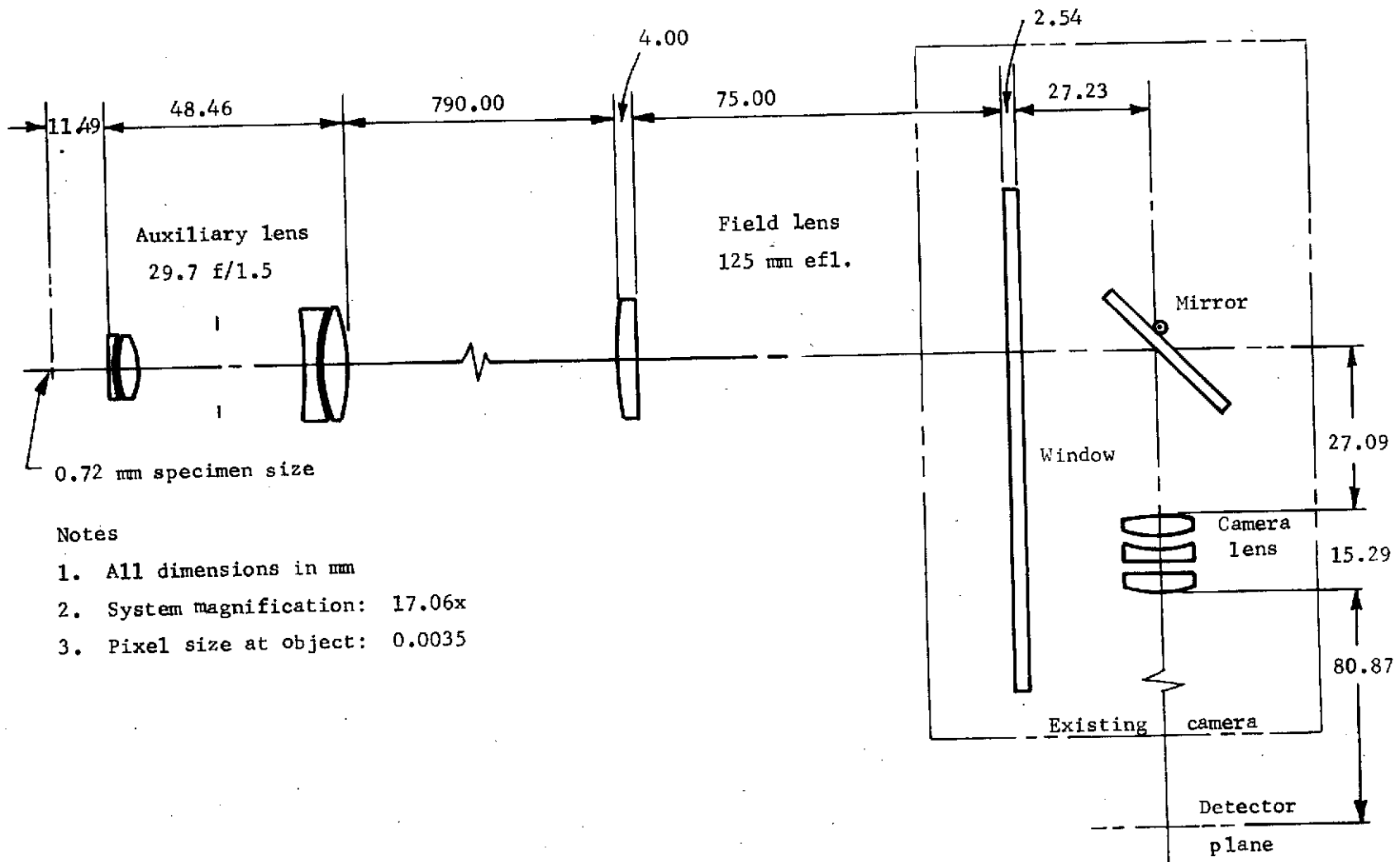

Notes

1. All dimensions in mm
2. System magnification: 17.06x
3. Pixel size at object: 0.0035

Figure 6. Final case I configuration

RAUL

10.20.50

04/30/73

CYCLE 9

WAVELENGTH NO. SURFACE	RADIUS	THICKNESS	0.80000 MU-INDEX	0.75000 HI-INDEX	0.95000 LO-INDEX	GL.CODE	PHI 1ST.BNDY	0.0 2ND.BNDY
1 SPHER.	-103.5726	1.5000	1.72305	1.72588	1.71691	SF 13	0.0	0.0
2 SPHER.	17.2426	0.5273	1.00000	1.00000	1.00000	AIR	0.0	0.0
3 SPHER.	21.8458	3.7067	1.61302	1.61424	1.61017	PSK 53	0.0	0.0
4 SPHER.	-1.9479	33.9943	1.00000	1.00000	1.00000	AIR	0.0	0.0
5 SPHER.	-338.5047	3.0133	1.67411	1.67650	1.66889	SF 8	0.0	0.0
6 SPHER.	29.2679	0.3465	1.00000	1.00000	1.00000	AIR	0.0	0.0
7 SPHER.	31.5953	5.2733	1.61302	1.61424	1.61017	PSK 53	0.0	0.0
8 SPHER.	-37.5443	790.0000	1.00000	1.00000	1.00000	AIR	0.0	0.0
9 SPHER.	75.0000	4.0000	1.61286	1.61417	1.60978	SK 16	0.0	0.0
10 SPHER.	INF	75.0000	1.00000	1.00000	1.00000	AIR	0.0	0.0
11 SPHER.	INF	2.5400	1.51078	1.51184	1.50823	BK 7	0.0	0.0
12 SPHER.	INF	54.3193	1.00000	1.00000	1.00000	AIR	0.0	0.0
13 SPHER.	37.2185	4.3180	1.49411	1.49516	1.49161	K 11	0.0	0.0
14 SPHER.	-31.2667	2.5400	1.00000	1.00000	1.00000	AIR	0.0	0.0
15 SPHER.	-21.1011	2.0320	1.65864	1.66091	1.65366	SF 5	0.0	0.0
16 SPHER.	-284.7471	2.5400	1.00000	1.00000	1.00000	AIR	0.0	0.0
17 SPHER.	-251.7245	3.8608	1.49411	1.49516	1.49161	K 11	0.0	0.0
18 SPHER.	-25.4039	8.8677	1.00000	1.00000	1.00000	AIR	0.0	0.0
19 SPHER.	INF	0.0	1.00000	1.00000	1.00000	AIR	0.0	0.0

FIRST ORDER PARAMETERS ON MERIDIONAL PLANE

OBJECT DISTNCE	ENTR.PUP.DIST	FRST.PPAL.PNT	EQV.FCL.LENGTH	SECO.PPAL.PNT	EXT.PUP.DSTNC	IMAGE DISTNCE
-11.491039	45.991527	-16.115319	-4.971647	2.161426	-3.160291	80.867661
OBJECT HEIGHT	ENTR.PUP.SIZE	OBJT.SPCE.FNO	TRACK LENGTH	IMGE.SPCE.FNO	EAT.PUPL.SIZE	IMAGE HEIGHT
0.375000	-34.321434	-1.530003	1081.929900	25.585700	3.284176	6.396413
MAGNIFICATION	SEMIANG.FIELD	BACK.VTX.DIST	BARREL LENGTH	FRNT.VTX.DIST	SEMIANG.FIELD	DEMAGNIFICATION
17.057130	-0.373781	1801.042239	989.571200	1070.438861	4.361494	0.058627
APT.STOP SIZE	APT.STOP DIST	FROM SRFCE.NO	*****	FLD.STOP SIZE	FLD.STOP DIST	FROM SRFCE.NO
14.512911	16.997150	4		12.792825	40.867661	18

Figure 7. Case I optical system prescription



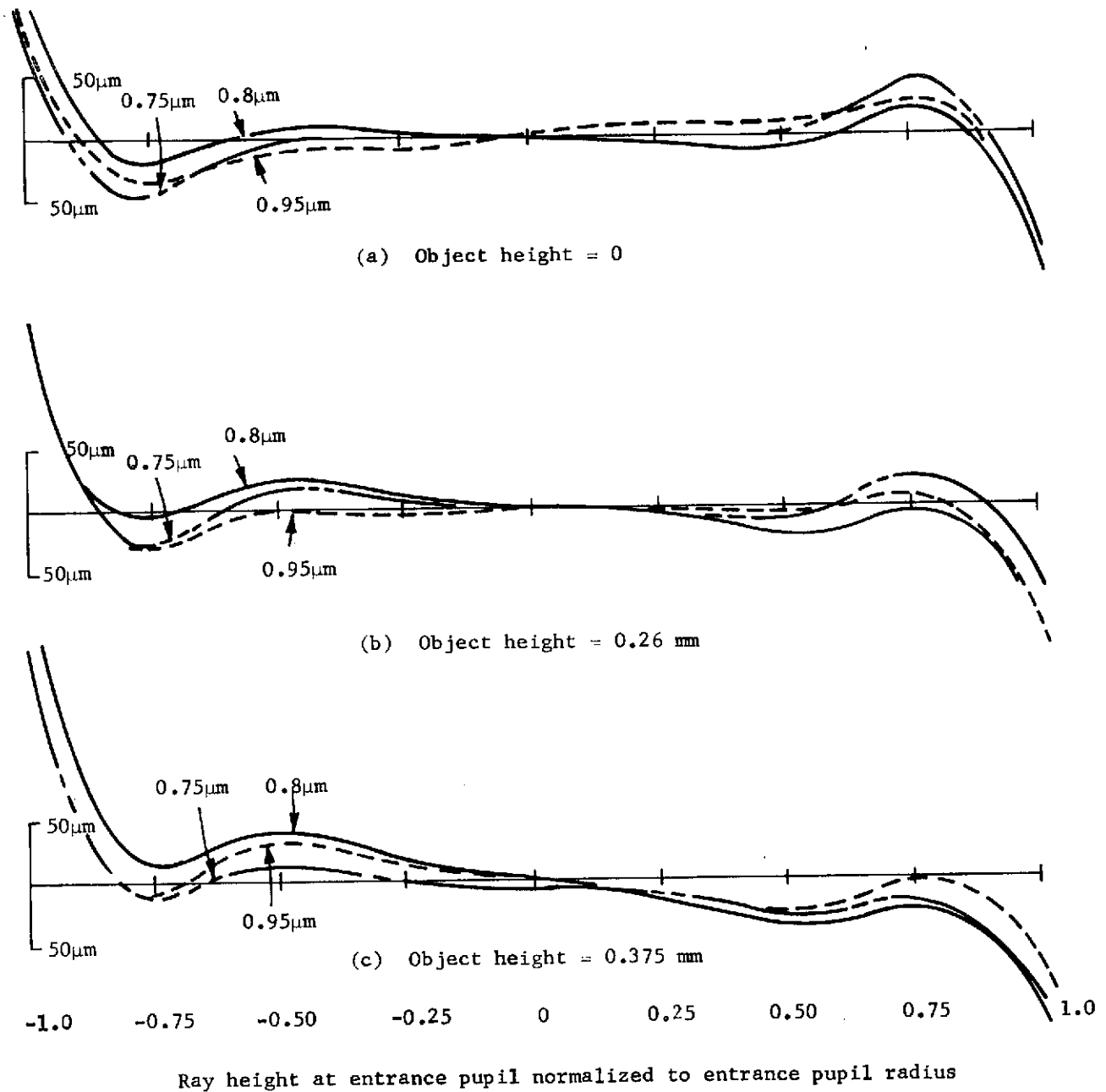

Figure 8. Case I -  $H \tan U$  curves at image plane

0.75, 0.8 and 0.95 micrometer wavelength light -- those wavelengths near the peak response of the silicon detector. The curves show the deviation of a ray from the chief ray, for various entrance pupil positions, at the Gaussian image plane. Since the angular resolution of the system is 0.0007 radian in the image space and since the detector is located 85.3 mm from the camera lens exit pupil, the detector collecting aperture is therefore  $0.0007 (85.3) = 0.0597$  mm in size. As can be seen from the scale of the curves (1 inch = 100 $\mu$ ), the 59.7 $\mu$ m aperture will collect most of the light except, of course, those near the margin of the entrance pupil.

A computer computation of the encircled energy is shown in Figure 9 for on-axis field points. Other field points are quite similar, as exemplified by the similarity of the Figure 8 aberration curves. Since the detector collecting radius is approximately 0.030 mm, Figure 9 shows that 86.3% of the energy is collected within the detector aperture.

Finally, a computer computation of the system MTF comprising the optical elements from the auxiliary lens up to, but not including, the detector is included in Figure 10, at a plane 1.0 mm downlight from the Gaussian image plane, which is the optimum plane for the system. A comparison between the theoretical and actual MTF values shows the design to be quite good, as corroborated by the high percentage of encircled energy noted above.

<u>Radius (mm)</u>	<u>Percentage energy</u>
0.01000	24.91468
0.02000	71.33106
0.03000	86.34812
0.04000	89.07856

Notes

1. At best image plane located 1.000 mm downlight from Gaussian plane
2. For 0.8 micrometer wavelength
3. On-axis object field point

Figure 9. Case I - encircled energy in image plane

	<u>Req</u>	<u>Theor</u>	<u>MTF</u>
	5.	0.875	0.807
	15.	0.625	0.519
	25.	0.393	0.320
	35.	0.190	0.169
	45.	0.040	0.031

Notes

1. At best image plane located 1.000 mm downlight from Gaussian plane
2. For 0.8 micrometer wavelength
3. On-axis object field point

Figure 10. Case I - modulation transfer function (MTF) values

The field of view at the object plane is so small for this case that MTF and encircled energy are not significantly different at the edge compared to the axial point, hence separate tables are not included.

#### 4.2 Case IV - Final Configuration Parameters

Figures 11 through 15 relate to the final Case IV design and are comparable to those noted for Case I. The salient features of this case are as follows.

As can be seen from the Figure 11 configuration, the overall system is exceedingly compact. Another advantage is that, since the image is in the same plane as the existing camera detector array, no additional detector is required. A possible disadvantage is that the system magnification is only 1.01x. Although light will not be vignetted by the camera lens except for object specimen elements greater than 20 mm in size, the design of the proposed auxiliary lens limits the specimen size to 10 mm due to excessive aberrations. This specimen size represents 266.7 pixel elements.

The detector collecting aperture (pixel element at the detector) is 0.0371 mm. Figures 13 and 14 show that a high percentage of the energy falls within that aperture, i.e., 100% and 98% energy for on-axis and 5.0 mm field points, respectively.

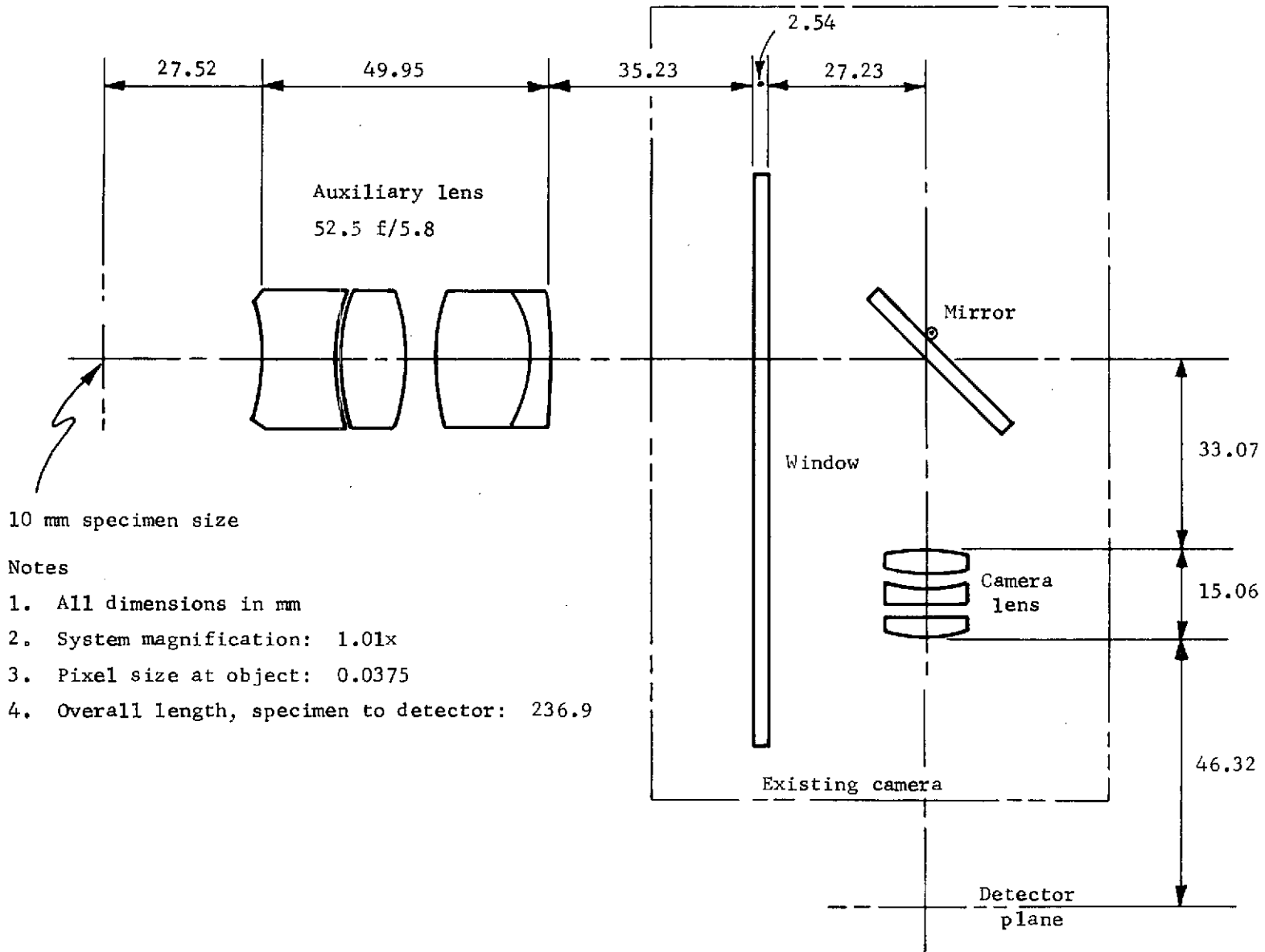

Figure 11. Final case IV configuration

QUASI MICROSCOPE CASE IV HAUL  
CYCLE 0

10.15.19 05/07/73

WAVELENGTH NO. SURFACE	RADIUS	THICKNESS	U-INDEX 0.80000 27.5186	M1-INDEX 1.00000	U-INDEX 0.75000 1.00000	U-INDEX 0.95000 1.00000	GL.CODE	PHI 1ST. BNDY	0.0 2ND. BNDY
1 SPHER.	-39.9083	13.2396	1.59677	1.59849	1.59295	BASF 3	0.0	0.0	
2 SPHER.	37.1344	0.4887	1.00000	1.00000	1.00000	AIR	0.0	0.0	
3 SPHER.	33.0958	11.1212	1.59965	1.60096	1.59562	SK 2	0.0	0.0	
4 SPHER.	-37.9341	5.6157	1.00000	1.00000	1.00000	AIR	0.0	0.0	
5 SPHER.	43.2887	16.4171	1.48224	1.48317	1.47996	FK 5	0.0	0.0	
6 SPHER.	-19.9589	3.0554	1.63474	1.63684	1.63012	SF 2	0.0	0.0	
7 SPHER.	-91.5822	35.2300	1.00000	1.00000	1.00000	AIR	0.0	0.0	
8 SPHER.	INF	2.5400	1.51078	1.51184	1.50823	SK 7	0.0	0.0	
9 SPHER.	INF	14.4508	1.00000	1.00000	1.00000	AIR	0.0	0.0	
10 SPHER.	INF	0.0	1.00000	1.00000	1.00000	AIR	0.0	0.0	
11 SPHER.	INF	45.8492	1.00000	1.00000	1.00000	AIR	0.0	0.0	
12 SPHER.	36.7296	4.2024	1.49412	1.49516	1.49161	K 11	0.0	0.0	
13 SPHER.	-29.8771	2.5073	1.00000	1.00000	1.00000	AIR	0.0	0.0	
14 SPHER.	-20.9085	2.0058	1.65864	1.66091	1.65366	SF 5	0.0	0.0	
15 SPHER.	-281.0820	2.5073	1.00000	1.00000	1.00000	AIR	0.0	0.0	
16 SPHER.	-248.4844	3.8111	1.49412	1.49516	1.49161	K 11	0.0	0.0	
17 SPHER.	-25.1558	46.3189	1.00000	1.00000	1.00000	AIR	0.0	0.0	
18 SPHER.	INF	0.0	1.00000	1.00000	1.00000	AIR	0.0	0.0	

TABLE OF DECENTRATIONS, FILTS AND ROTATIONS

NO.	TYPE	Y-DEC.	Z-DEC.	Y-TILT	Z-TILT	ROT.
10	2	0.0	0.0	4.500000 01	0.0	0.0
11	1	0.0	0.0	-7.482400 00	0.0	0.0

FIRST ORDER PARAMETERS ON MERIDIONAL PLANE

OBJECT DISTNCE	ENTR.PUP.DIST	FRST.PPAL.PNT	EQV.FCL.LENGTH	SCND.PPAL.PNT	EXT.PUP.DISTN	IMAGE DISTNCE
-27.518815	-1362.669441	-4587.592929	-2290.816033	4649.713719	-3254.126308	46.318901
OBJECT HEIGHT	ENTR.PUP.SIZE	OBJT.SPCE.FNO	TRCK LENGTH	IMG.SPCE.FNO	EXT.PUPL.SIZE	IMAGE HEIGHT
6.900000	-232.365268	5.745419	236.939317	5.000000	569.904346	-6.965550
MAGNIFICATION	SEMIANG.FIELD	BACK VTX.DIST	BARREL LENGTH	FPMI.VTX.DIST	SEMIANG.FIELD	DEMAGNIFICATION
-1.009500	0.296102	190.620415	163.101660	209.420502	-0.120739	-0.990589
APT.STOP SIZE	APT.STOP DIST	FROM SRFC.NO	*****	FLD.STOP SIZE	FLD.STOP DIST	FROM SRFC.NO
9.141349	0.0	10		-13.931100	46.318901	17

Figure 12. Case IV - optical system prescription



(a) Object height = 0

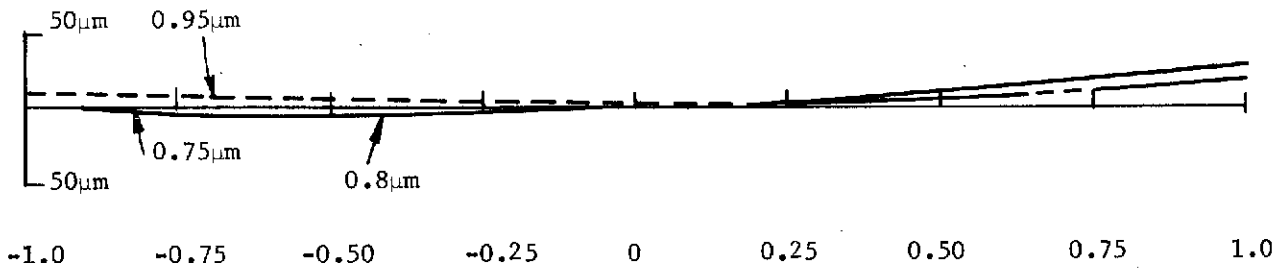

(b) Object height = 5.0 mm

Ray height at entrance pupil normalized to entrance pupil radius

Figure 13. Case IV -  $H \tan U$  curves at image plane

<u>Radius (mm)</u>	<u>Percentage energy</u>	
	<u>On-axis</u>	<u>5.0 mm object field</u>
0.0030	6.410	24.573
0.0070	82.253	63.481
0.0110	100.000	78.498
0.0150	100.000	91.126
0.0190	100.000	98.635

Notes

1. At best image plane located 0.100 mm uplight from Gaussian plane
2. For 0.8 micrometer wavelength

Figure 14. Case IV - encircled energy in image plane

	<u>Theor</u>	<u>On-axis</u>	<u>5.0 mm object field</u>
	0.943	0.929	0.872
	0.886	0.850	0.691
	0.829	0.777	0.534
	0.771	0.713	0.416
	0.714	0.654	0.328
	0.657	0.600	0.260
	0.600	0.549	0.205
	0.543	0.498	0.159

Notes

1. At best image plane located 1.000 mm downlight from Gaussian plane
2. For 0.8 micrometer wavelength

Figure 15. Case IV - MTF values

## 5. CONCLUSIONS

It is concluded, as a result of the work described and reported in Section 4, that either Case I or Case IV provides a viable configuration for satisfying the requirement for a Quasi-Microscope.

Case I is clearly more favorable from the standpoint of information-gathering capability. It provides magnification at a level comparable to that which would be considered desirable for the initial examination of soil specimens in an earth laboratory and has a field of view adequate for such an examination. It requires that a detector be placed in the Facsimile Camera in an inconvenient location, considerably separated from the existing detector plane. There appears, however, that a solution to this problem exists -- see Section 6.

Case IV provides a limited magnification and can probably be configured to be useful without artificial illumination of the specimen. It does not require any modification of the existing Facsimile Camera (except for its control in a "Microscope" mode).

Either configuration makes the system much more sensitive to focus than is the case for the existing Facsimile Camera situation. This is an inevitable consequence of the magnification and is proportional to its square. There is no escape from this sensitivity, but there are probably methods by which the equipment may be designed to cope with it effectively. This is beyond the scope of the current work and is proposed as a subject for follow-on investigations.

## 6. DESIRABLE EXTENSIONS OF WORK

The work which has been accomplished under the existing contract has fully covered -- even slightly exceeded -- the scope of effort initially set forth. In the course of the work, the desirability of investigating areas not covered by this contract has become evident. These areas are as follows:



(a) Adaptation to Existing Facsimile Camera Focal Plane

The principal disadvantage of the most desirable configuration explored -- Case I -- is that it results in a final image within the Facsimile Camera which is considerably displaced along the optical axis from the nominal focal plane for terrain observation. First order optical considerations indicate that it is possible to compensate for this situation by the provision of an additional optical element in the train. This additional element relays the intermediate image to infinity, and thus permits the Facsimile Camera to be used exactly as it is used for terrain viewing. The additional element essentially forms an eyepiece, and converts the complete auxiliary optical system into a compound microscope. It is illustrated schematically in Figure 16.

(b) Compact Optical Arrangement

In the course of discussions between Perkin-Elmer and NASA-Langley personnel at the March 22 meeting, it became evident that an especially compact arrangement for the Quasi-Microscope could be achieved if the auxiliary lens (and the specimen table) could be incorporated in the already existing vertical pole which serves a protective function in the "stow" position of the Facsimile Camera. This would permit the overall length of the optical system, including the Facsimile Camera, to be no more than 100-200 mm, which would facilitate a generous field of view and magnification no less, and possibly greater, than that provided by the initial Case IV. In the final design of Case IV (Figure 11), this reduction in length has been incorporated. The mechanical advantages deriving from this arrangement are recommended for exploration.

(c) Mechanical Arrangements

Investigation of mechanical arrangements for the Quasi-Microscope and for the introduction of specimens to the object plane, including arrangements for critical focusing, for sun-directed and for artificial illumination where required, was not a part of the current contract. It is evident, however, that such items are intimately related to the feasibility of implementing a particular optical arrangement to the Viking Lander.

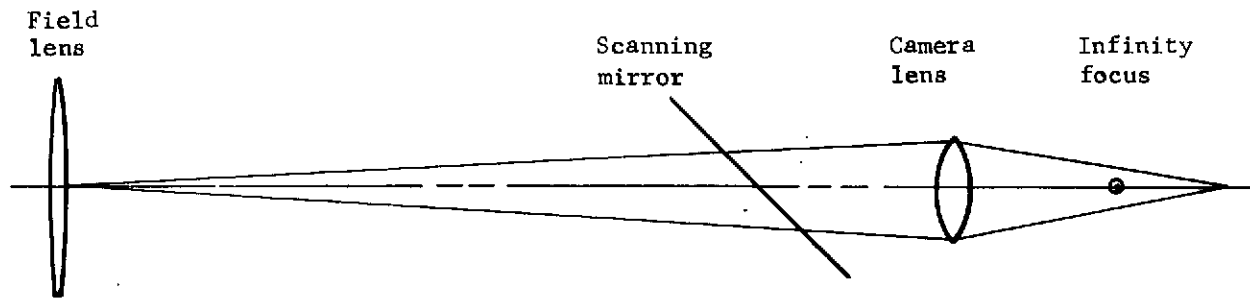

Case I - nominal arrangement

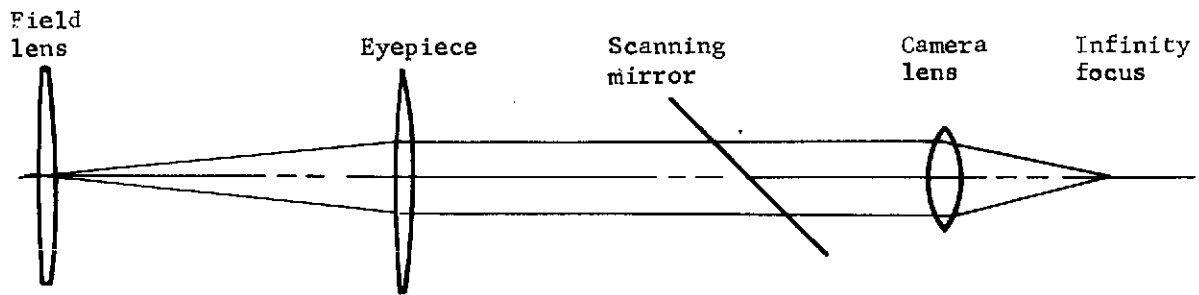

Modification to add "eyepiece"

Figure 16. Potential modification to system (schematic)

Therefore, it appears that there is a considerable amount of further investigation which can produce valuable results in terms of identifying a viable Quasi-Microscope system for incorporation in a follow-on Viking mission. A proposal for such further studies, carrying on from the present status as reported herein, and including the items identified above, as well as others, will be submitted to NASA-Langley in the immediate future.

APPENDIX A  
PHOTOMETRIC ANALYSIS

A1. REQUIRED OBJECT IRRADIANCE

A1.1 For Unaided Camera

$$E_c = \frac{4}{k_c R_o} N^2 E_1 \quad (A1)$$

where:

- $E_c$  = Required object irradiance for the unaided camera  
 $k_c$  = Optical efficiency of the unaided camera system  
 $R_o$  = Reflectivity of the irradiated object  
 $N$  = Aperture ratio of unaided camera at infinity focus  
 $E_1$  = Required irradiance of the unaided camera detector for a desired SNR (signal-to-noise ratio)

A1.2 For Quasi-Microscope

$$E_{QM} = \frac{4}{k_{QM} R_o} m^2 F_o^2 E_1 \quad (A2)$$

where:

- $E_{QM}$  = Required object irradiance for the Q-M  
 $k_{QM}$  = Optical efficiency of the Q-M system  
 $R_o$  = as above  
 $m$  = Overall system magnification of the Q-M  
 $F_o$  = Object bundle aperture ratio into the Q-M  
 $E_1$  = as above, but for the Q-M

APPENDIX A

A2. REQUIRED OBJECT IRRADIANCE FOR QUASI-MICROSCOPE  
NORMALIZED TO UNAIDED CAMERA

Taking the ratio of (A2) to (A1), with the assumption that  $k_c = k_{QM}$  and that

$$E_{1,c} = E_{1,QM}$$

$$\frac{E_{QM}}{E_c} = \left( \frac{m f_o}{N} \right)^2 \quad (A3)$$

let  $N = 5.58$

Using the noted values for each Q-M case:

TABLE A1  
Q-M CASE VALUES

Q-M Case	m	f <sub>o</sub>	E <sub>QM</sub> /E <sub>c</sub>
I	14.8	1.50	15.83
II	3.87	1.53	1.13
III	2.67	2.22	1.13
IV	1.10	6.30	1.54

A3. IRRADIANCE OF UNAIDED CAMERA DETECTOR FOR DESIRED SNR

It is assumed that the desired SNR is achieved in the unaided camera simply by the sufficiency of the Sun's irradiation of the observed object.

Let in (A1):

$$E_c = E_{Sun} \quad (A4)$$

From Paragraph A5 or A6, it is shown that for a silicon detector (spectral sensitivity range of 0.54 $\mu$  to 1.1 $\mu$ ), the irradiance of Mars due to the Sun is

$$E_{Sun} = 0.028 \text{ w/cm}^2$$

## APPENDIX A

Also let

$$k_c = 0.75$$

$$R_o = 0.20$$

$$N = 5.58$$

from (A1) and (A4):

$$E_1 = \frac{k_c R_o}{4} \frac{E_{Sun}}{N^2}$$

$$= \frac{0.75(0.20)}{4} \frac{0.028}{(5.58)^2} = 3.37 \times 10^{-6} \text{ w/cm}^2$$

### A4. ARTIFICIAL SOURCE REQUIRED FOR OBJECT IRRADIANCE OF QUASI-MICROSCOPE

#### A4.1 Required Object Irradiances

From Paragraph A3,

$$E_c = E_{Sun} = 0.028 \text{ w/cm}^2$$

Using this value in Table A1, we have for the required object irradiance for each Q-M Case:

TABLE A2  
REQUIRED OBJECT IRRADIANCE

Q-M Case	$E_{QM} \text{ w/cm}^2$
I	0.443
II	0.031
III	0.031
IV	0.043

## APPENDIX A

### A4.2 Detector Size

Unaided camera angular resolution = 0.0007 rad

Unaided camera focal length = 5.40 cm

Unaided detector pixel size  $(P)_d = 5.40 (0.0007) = 0.00378$  cm

No. of detector pixels = 500

No. of detector size  $(\ell)_d = 500 (0.00378) = 1.890$  cm

### A4.3 Q-M Object Pixel and Field Size

Case I only will be treated since, from Table A2, it can be seen that the other cases can almost utilize the sun's illumination of the object.

$$\text{Case I object pixel } P_o = \frac{P_d}{m} = \frac{0.00378 \text{ cm}}{14.8} =$$

$$P_o = 2.55 \times 10^{-4} \text{ cm}$$

and Case I object size  $\ell_o = \frac{\ell_d}{m} = \frac{1.890 \text{ cm}}{14.8}$

$$\ell_o = 0.128 \text{ cm}$$

### A4.4 Artificial Source Required for Case I

From Appendix B, a 1974 GE Quartzline 20W lamp has a filament size of 0.178 x 0.203 cm. Since this filament size sufficiently covers the required object size  $(\ell_o)$ , let this lamp source be imaged 1:1 in a collection optical system of 2.0 input bundle aperture ratio. Since

$$E_o = \frac{\pi}{4} \frac{k B_o}{m^2 F_o^2}$$

## APPENDIX A

where:

$E_o$  = Irradiance of object from artificial source

$h$  = Optical efficiency of collecting optics = 0.85

$B_o$  = Radiance of source =  $4.84 \text{ w/cm}^2\text{-sr}$

$m$  = 1

$F_o$  = 2.0

Therefore,

$$E_o = \frac{\pi}{4} \frac{0.85 (4.84)}{(1)^2 (2)^2} = 0.808 \text{ w/cm}^2$$

This available irradiance is 1.8X that required for Case I (see Table A2 where  $E_{QM} = 0.443 \text{ w/cm}^2$ ).

### A5. AVAILABLE IRRADIANCE ON MARS FROM SUN USING SILICON DETECTOR

As shown in Figure A1, the wavelength range for the approximate average Silicon D\* is between  $0.54$  and  $1.1\mu$ . Therefore, Sun's irradiance

$$\text{at } 0.54\mu = 0.195 \text{ w/cm}^2\text{-}\mu$$

and

$$\text{at } 1.1\mu = 0.065 \text{ w/cm}^2\text{-}\mu$$

Therefore, the approximate average Sun's irradiance ( $E_o$ ) between  $0.54$  and  $1.1\mu$

$$\begin{aligned} &= \frac{0.195 + 0.065}{2} \\ &= 0.130 \text{ w/cm}^2\text{-}\mu \end{aligned}$$



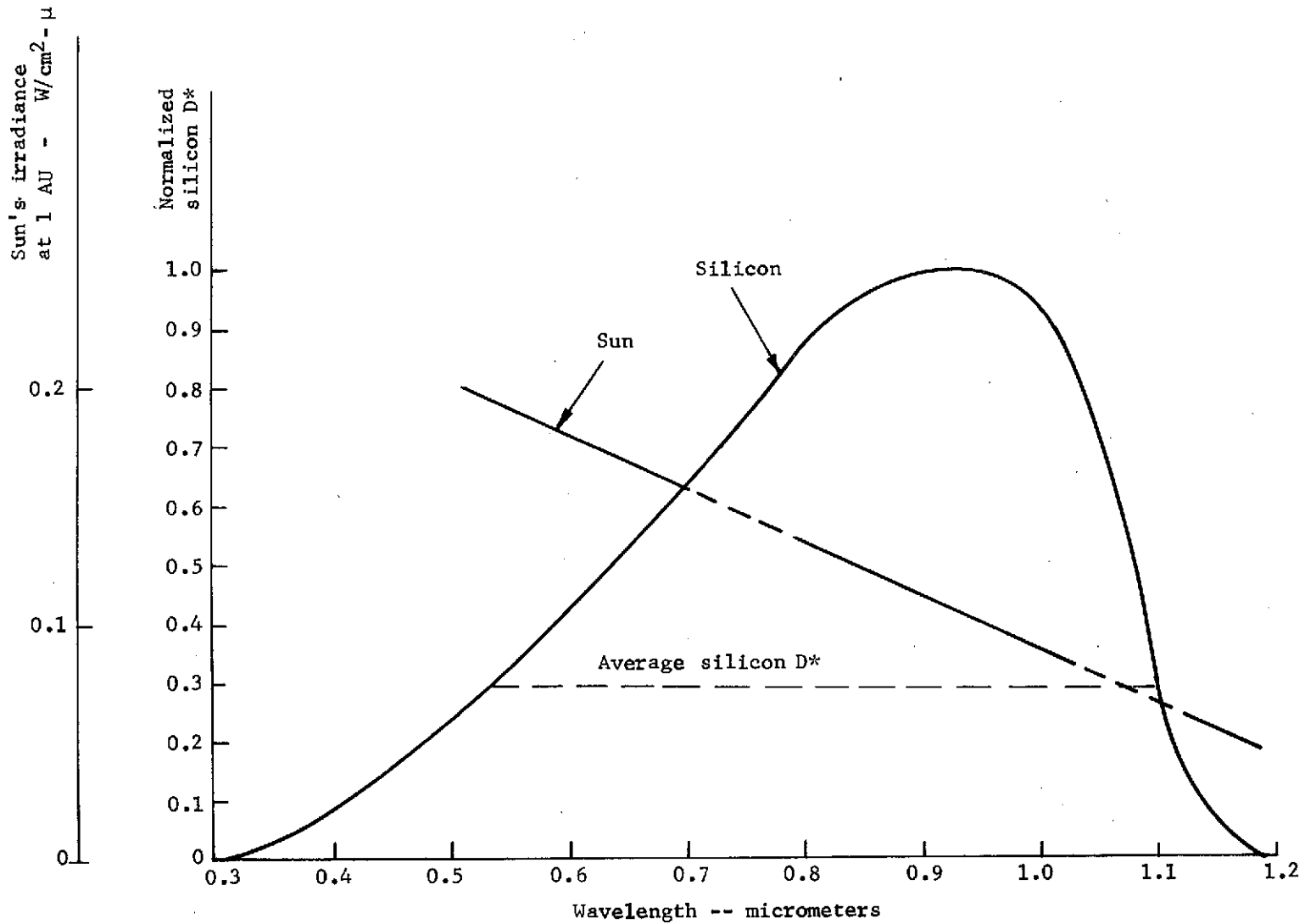

Figure A1. Spectral irradiance of sun and silicon  $D^*$

APPENDIX A

Therefore, for the region between 1.10 and 0.54 $\mu$ ;  $\Delta\lambda = 0.56\mu$

$$E_o \text{ at 1 AU} = 0.130 \text{ w/cm}^2 \cdot \mu (0.56\mu) = 0.073 \text{ w/cm}^2$$

$$\text{Mars} = 1.6 \text{ AU}$$

Therefore, the available  $E_o$  on Mars for the silicon detector is:

$$\text{available } E_o = \frac{0.073}{(1.6)^2} = 0.028 \text{ w/cm}^2$$

A6. ALTERNATE METHOD FOR DETERMINING IRRADIANCE OF MARS IN SILICON DETECTOR REGION BETWEEN 0.5 AND 1.1 $\mu$

$$\text{Sun} = 5750^\circ\text{K}$$

$$\text{let } e = 1.0 \text{ (emissivity)}$$

$$\text{Therefore, } E \text{ at Sun's surface} = 6.0 \times 10^3 \text{ w/cm}^2$$

$$\% \text{ of total energy below } 0.5\mu = 25$$

$$\% \text{ of total energy below } 1.1\mu = 77$$

$$\therefore \% \text{ energy in the region } 0.5\mu \text{ to } 1.1\mu = 77.0 - 25.0 = 52$$

$$\therefore E \text{ at the Sun's surface in the region } 0.5\mu \text{ to } 1.1\mu = 6.0 \times 10^3 \times 0.52$$

$$\therefore E_{\text{Sun}} \int_{\Delta\lambda} = 3.12 \times 10^3 \text{ w/cm}^2$$



APPENDIX A

$$r_s = 0.696 \times 10^6 \text{ km}$$

$$r_m = 1.6 \text{ AU } (149.4 \times 10^6 \text{ km/AU}) = 239.04 \times 10^6 \text{ km}$$

$$\begin{aligned} \text{Therefore, } E_{\text{Mars}} ]_{\Delta \lambda} &= E_{\text{Sun}} ]_{\Delta \lambda} \cdot \left( \frac{r_s}{r_m} \right)^2 \\ &= 3.12 \times 10^3 \frac{\text{w}}{\text{cm}^2} \cdot \left( \frac{0.696 \times 10^6}{239.04 \times 10^6} \right)^2 \end{aligned}$$

Therefore, available  $E_{\text{Mars}} ]_{\Delta \lambda} = 0.026 \text{ w/cm}^2$

APPENDIX B

GE NO. 1974 QUARTZLINE LAMP

B1. CATALOG CHARACTERISTICS

6V

20W

10 cp  $J = 10 \frac{\ell}{\text{sr}}$  intensity

C6 filament

10,000 hr life

2500 °K color temperature

0.178 cm x 0.203 cm filament size

$$\text{Therefore, Luminance } B = \frac{10 \ell/\text{sr}}{0.178(0.203)\text{cm}^2} = 276.7 \frac{\ell}{\text{cm}^2\text{-sr}}$$

B2. FOR TUNGSTEN AT 2550°K

$$\text{average between } 0.55\mu \text{ to } 1.05\mu = 350 \frac{\mu \text{ W}}{100\text{A}\cdot\ell}$$

$$\therefore \text{ from } 0.55\mu \text{ to } 1.05\mu = 0.50\mu = 5000\text{Å}$$

$$\therefore \text{ conversion efficiency} = 350 \frac{\mu \text{ W}}{100\text{A}\cdot\ell} \times 5000\text{Å} = 17.5 \times 10^3 \frac{\mu \text{ W}}{\ell}$$

$$\therefore \text{ conversion efficiency} = 17.5 \times 10^{-3} \frac{\text{W}}{\ell}$$

$$\therefore J = 10 \frac{\ell}{\text{sr}} \cdot 17.5 \times 10^{-3} \frac{\text{W}}{\ell} = 0.175 \frac{\text{W}}{\text{sr}}$$

$$\text{and Radiance } B = 276.7 \frac{\ell}{\text{cm}^2\text{-sr}} \cdot 17.5 \times 10^{-3} \frac{\text{W}}{\ell} = 4.84 \frac{\text{W}}{\text{cm}^2\text{-sr}}$$

APPENDIX B

B3. EFFECT OF DERATING 1974 GE QUARTZLINE LAMP

Let:

$v, \ell, (\ell/w)$  = New voltage, life, lumens/watt

$V, L, (L/W)$  = Rated voltage, life, lumens/watt

$$\ell = L \left( \frac{v}{V} \right)^{13.1}$$

for  $v = 0.8V$

and  $L = 10^4$  hr

$$\ell = 10^4 \left( \frac{v}{0.8V} \right)^{13.1} = 10^4 \cdot (1.25)^{13.1} = 10^4 (18.6)$$

Therefore

$$\ell = 18.6 \times 10^4 \text{ hr}$$

and

$$\frac{\ell}{w} = \left( \frac{L}{W} \right) \left( \frac{v}{V} \right)^{1.84}$$

for  $v = 0.8V$

and  $\left( \frac{L}{W} \right) = 57.14 \frac{\text{lumens}}{\text{watt}}$

$$\frac{\ell}{w} = 57.14 (0.8)^{1.84} = 57.14 (0.663)$$

Therefore

$$\frac{\ell}{w} = 37.90 \frac{\text{lumens}}{\text{watt}}$$

APPENDIX B

Therefore, the new conversion efficiency =  $\frac{1}{37.90} = 0.026$  watts/lumen

$$\text{and } \frac{\text{new lumen}}{\text{rated lumen}} = \left(\frac{v}{V}\right)^{3.38} = (0.8)^{3.38} = 0.470$$

$$\therefore \text{new J} = 10 \frac{\ell}{\text{sr}} (0.47) = 4.7 \ell/\text{sr}$$

$$\text{and new B} = \frac{4.7 \ell/\text{sr}}{0.178(0.203)\text{cm}^2} = 130.07 \frac{\ell}{\text{cm}^2\text{-sr}}$$

$$= 130.07 \frac{\ell}{\text{cm}^2\text{-sr}} \cdot 0.026 \frac{\text{w}}{\ell} = 3.38 \frac{\text{w}}{\text{cm}^2\text{-sr}}$$

$$\therefore \text{new } E_o = \text{old } E_o \cdot \frac{\text{new B}}{\text{old B}}$$

$$= 0.808 \frac{\text{w}}{\text{cm}^2} \cdot \frac{3.38}{4.84} = 0.565 \frac{\text{w}}{\text{cm}^2}$$