

1 OF 1

N74 12506 UNCLAS

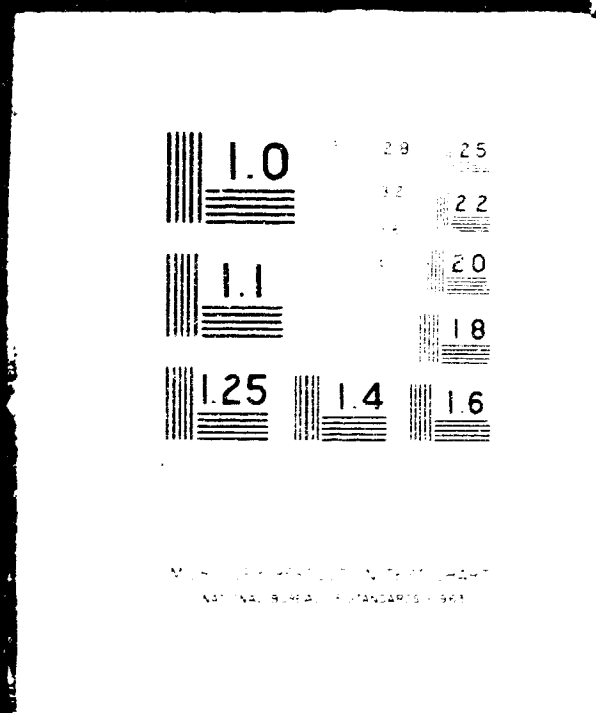

NATIONAL BUREAU OF STANDARDS - 1963

B.F. Goodrich

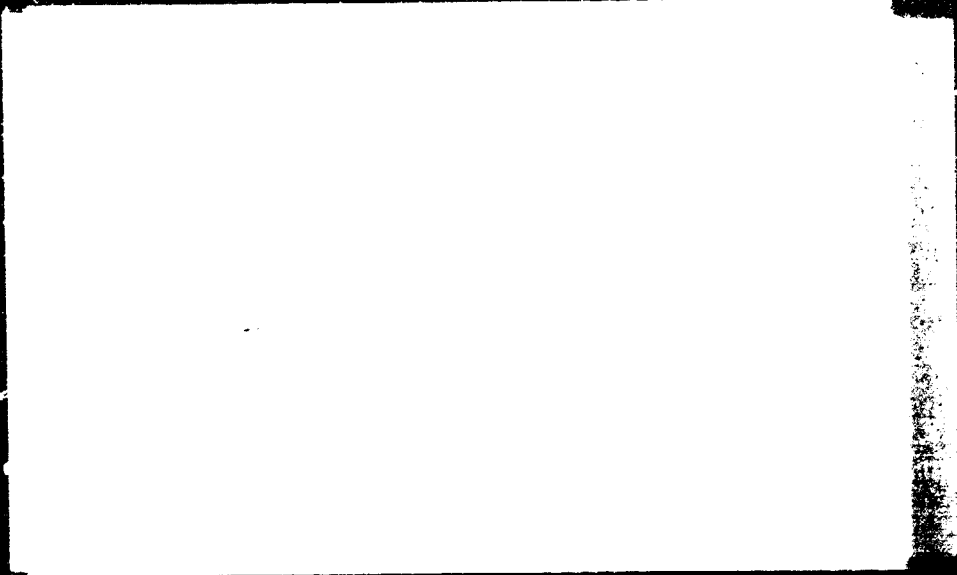

(NASA-CR-134130) ENGINEERING REPORT.
PART 3: NASA LIGHTWEIGHT WHEEL AND
BRAKE SUB-SYSTEM. LIGHTWEIGHT BRAKE
DEVELOPMENT (Goodrich (B. F.) Co.) 85 p
HC \$6.25
N74-12506
CSCL 22B G3/31 Unclas
22835

B.F. Goodrich Aerospace & Defense Products
A Division of The B.F. Goodrich Company
Wheel and Brake Plant
Troy, Ohio

NASA Contract No. NAS-9-12049
DRL No. Exhibit "A"
Line Item No. 9
DRD No. MA-129T

CR-134130

ENGINEERING REPORT NO. 4239
NASA LIGHTWEIGHT WHEEL AND BRAKE
SUB-SYSTEM CONTRACT WITH
B. F. GOODRICH

PART III
LIGHTWEIGHT BRAKE DEVELOPMENT

October 5, 1973

B. F. GOODRICH AEROSPACE & DEFENSE PRODUCTS

Wheel and Brake Plant

Troy, Ohio



H. C. Sunderman
Chief Engineer

ER-4239
FSC 97153
Part III

TABLE OF CONTENTS

| | Page |
|--|---------|
| TITLE PAGE | i |
| DISTRIBUTION LIST | iii |
| TABLE OF CONTENTS | v - vi |
| ABSTRACT | vii |
| SUMMARY | ix |
| RESULTS | xi - xv |
| CONCLUSIONS and RECOMMENDATIONS | xvii |
| INTRODUCTION | 1 - 2 |
| STRUCTURAL CARBON HEAT SINK DESCRIPTION | 3 - 4 |
| BERYLLIUM HEAT SINK DESCRIPTION | 5 - 6 |
| PRELIMINARY BRAKE SIZING AND TRADE-OFFS | 7 - 8 |
| Proposed Heat Sink Criteria | 9 |
| Areas of Investigation - Structural Carbon Brake | 10 |
| - Carbon Lined Beryllium | 10 |
| Proven Areas | 10 - 11 |
| PROGRAM PLAN | 11 |
| PHASE I - TWO-ROTOR BRAKE TEST | |
| Objective | 12 |
| Test Results | 12 - 19 |
| Problem Areas | 20 |
| Thermal Stress | 21 - 22 |

ER-4239
FSC 97153
Part III

TABLE OF CONTENTS

| | Page |
|--|--------------|
| PHASE II - FINAL DESIGN AND TEST | |
| Space Shuttle Requirements | 23 - 24 |
| Weight Comparison | 25 - 26 |
| Program Description | 27 |
| STRUCTURAL CARBON PROTOTYPE TEST | |
| TWO-ROTOR BRAKE | 28 - 35 |
| STRUCTURAL CARBON -- FIVE-ROTOR BRAKE TEST | 36 - 39 |
| FINAL DESIGN - STRUCTURAL CARBON BRAKE | 40 |
| CARBON LINED BERYLLIUM PROTOTYPE TEST | |
| SINGLE-ROTOR, 16-INCH DIAMETER PARTS | 42 - 45 |
| CARBON LINED BERYLLIUM -- FIVE-ROTOR BRAKE TEST | 46 - 52 |
| Problem Area | 53 |
| Solutions | 54 |
| FINAL DESIGN -- CARBON LINED BERYLLIUM BRAKE | 58 - 59 |
| REFERENCES | 61 |
| APPENDIX A | |
| Carbon Brake Failure Analysis | |
| Number 4 Stator, P/N 133-387-1 | A-1 thru A-6 |
| APPENDIX B | |
| Stress Analysis - Structural Beryllium Heat Sink | |
| P/N 2-1279-3 | B-1 thru B-4 |

Report Written by:
L. D. Bok

Approved by:

| | |
|---|---|
|  |  |
|---|---|

ER-4239
FSC 97153
Part III

ABSTRACT

This investigation covers the development of light weight wheel and brake systems designed to meet the space shuttle type requirements. The investigation covers using carbon graphite composite and beryllium as heat sink materials and the compatibility of these heat sink materials with the other structural components of the wheel and brake.

SUMMARY

The space shuttle is extremely weight sensitive, particularly with respect to auxiliary systems such as landing gear. Its brake requirements differ from most aircraft in that it requires high performance with low life.

The investigation was to develop a lightweight braking system using a 49 x 17-20 wheel and tire assembly capable of absorbing 42×10^6 ft-lbs for five stops and 70×10^6 ft-lbs for one stop. Two lightweight braking systems were considered for evaluation. The first utilized structural carbon as the heat sink material and the second used carbon lined beryllium. This development program was to advance the present state of the art of existing designs, and no new technology was developed.

The investigation showed that both brake designs were capable of meeting the space shuttle type requirements. The initial weight and cost advantage was with the structural carbon heat sink, operating at 2000°F and 2800°F for the five and one stop requirement respectively. Phase I and II tests indicated that operating at these high energies and temperatures cause thermal cracking of the structural carbon disks and a wheel and tire temperature compatibility problem. Increasing the mass of the carbon heat sink to a level where its operating temperature would be compatible with the wheel and tire, gave the weight and cost advantage to the carbon lined beryllium brake.

Tests on the carbon lined beryllium brake demonstrated its capability to meet, and its compatibility with the wheel and tire for the five stop requirement. Problems did develop with the mechanical attachment of the carbon lining to the beryllium core and the one stop requirement was not performed. The solution to the problem is evident and the analytical analysis shows the brake capable of meeting the requirements.

PRECEDING PAGE BLANK NOT FILMED

ER-4239
Part III
FSC 97153

RESULTS

The initial and final weight trade-offs between the structural carbon and carbon lined beryllium brakes are shown on Table I. Mass had to be added to the carbon heat sink to lower its operating temperature for the five stop requirement from 2000°F to 1600°F to be compatible with the wheel and tire. There was a 7.2 pound increase in weight of the beryllium brake and wheel assembly due to the redesign in the carbon lining attachment and the addition of wheel heat shields. The final weight trade-off shows the carbon lined beryllium brake and wheel assembly to be 27.6 pounds lighter than the structural carbon brake and wheel assembly.

~~PRECEDING PAGE BLANK NOT FILMED~~

TABLE I
 WEIGHT TRADEOFF

| | 5-Rotor Structural Carbon | | 5-Rotor Carbon Lined Beryllium | |
|-----------------------|---------------------------|-------|--------------------------------|-------|
| | INITIAL | FINAL | INITIAL | FINAL |
| ROTORS | 34.5 | 47.3 | 43.4 | 44.8 |
| STATORS | 27.6 | 37.8 | 34.7 | 37.3 |
| WEAR PLATE | 6.9 | 9.5 | 4.5 | 5.7 |
| BACK PLATE | 7.7 | 7.7 | 9.1 | 9.1 |
| TORQUE TUBE | 24.2 | 30.9 | 13.6 | 13.6 |
| PISTON HOUSING ASSY. | 23.4 | 23.4 | 20.3 | 20.3 |
| INSULATION | 1.8 | 1.8 | --- | --- |
| TOTAL BRK. ASSY. WT. | 126.1 | 158.4 | 125.6 | 130.8 |
| WHEEL ASSY. WEIGHT | 151.3 | 151.3 | 149.3 | 151.3 |
| TOTAL WHL. & BRK. WT. | 277.4 | 309.7 | 274.9 | 282.1 |
| | | 32.3 | | 7.2 |
| | | | | 27.6 |

RESULTS
(cont'd)

Graph No. 1 shows the results of the temperature survey performed on the carbon lined beryllium brake for the five stop requirement. The wheel temperatures were approaching their limit with a brake heat sink temperature of 1200°F. The addition of the wheel heat shields will lower these temperatures to a safe level, but would not maintain these levels for an equivalent weight structural carbon brake that operates at 2000°F.

GRAPH NO. 1
TEMPERATURE SURVEY
CARBON LINED BERYLLIUM BRAKE
KE = 42×10^6 FT-LBS

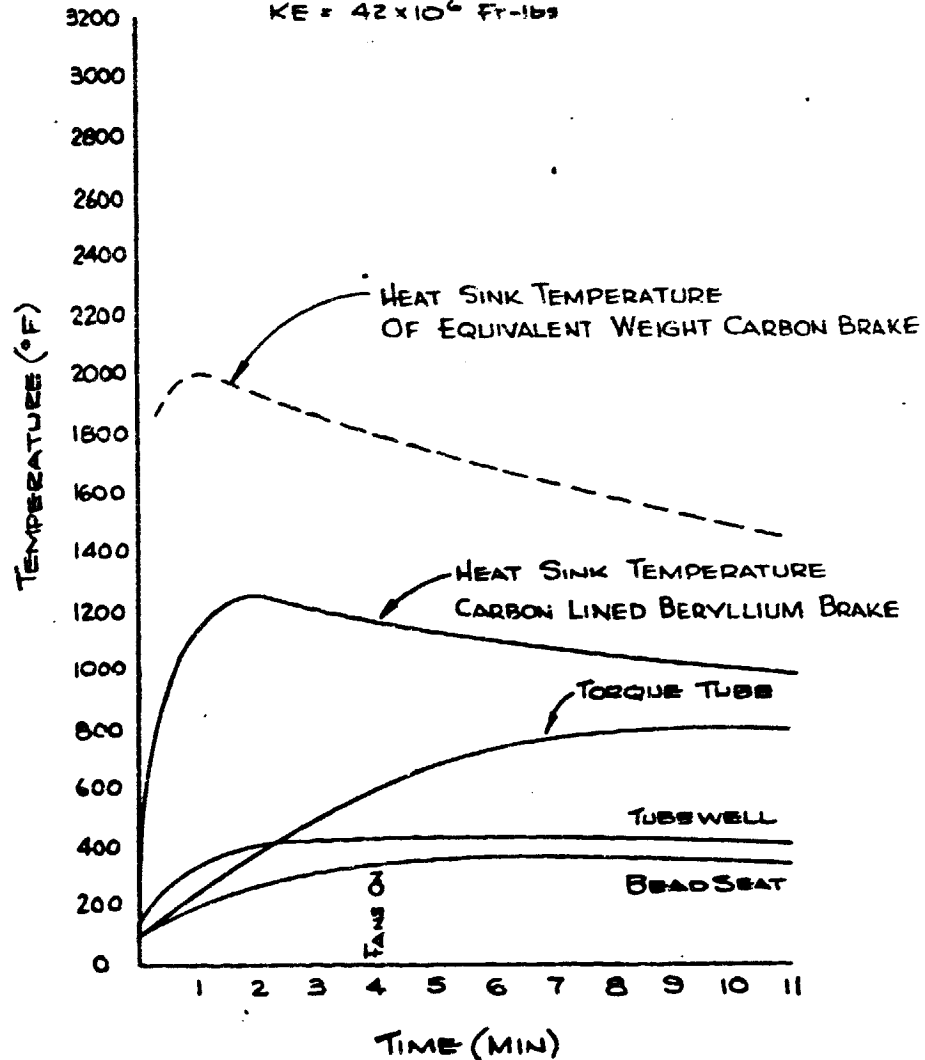

RESULTS
 (cont'd)

The heat sink temperatures established for the brakes are shown on Graph No. 2. For the space shuttle requirement, the carbon lined beryllium brake saves 27.6 pounds per assembly and operates 400 to 500° cooler than the carbon brake. The wear rate for the carbon lining material, which was used on both brake designs, was .0002 / .0003 inches per surface per stop for the five stop requirement. The five stop condition would only require .0015 inches of lining per surface.

The following weight cost trade-off indicates that the beryllium brake would cost more but should be justified by the total weight saved.

WEIGHT COST TRADE-OFF

| Description | Weight lbs | Weight Saved lbs | Budgetary Prices** | * Cost/ lbs saved |
|---|---------------|---------------------|-----------------------|----------------------|
| Structural Carbon Brake Assembly P/N 2-1279-2 | 158.4 | --- | \$20,000 | |
| Carbon Lined Beryllium Brake Assembly P/N 2-1279-3 | 130.8 | 27.6 | 22,000 | \$72.50 |

** Based on a hundred piece order.

* $\text{Cost/lb Saved} = \frac{\text{difference in weight}}{\text{difference in cost}}$

GRAPH NO. 2
HEAT SINK TEMPERATURE
VS
KINETIC ENERGY

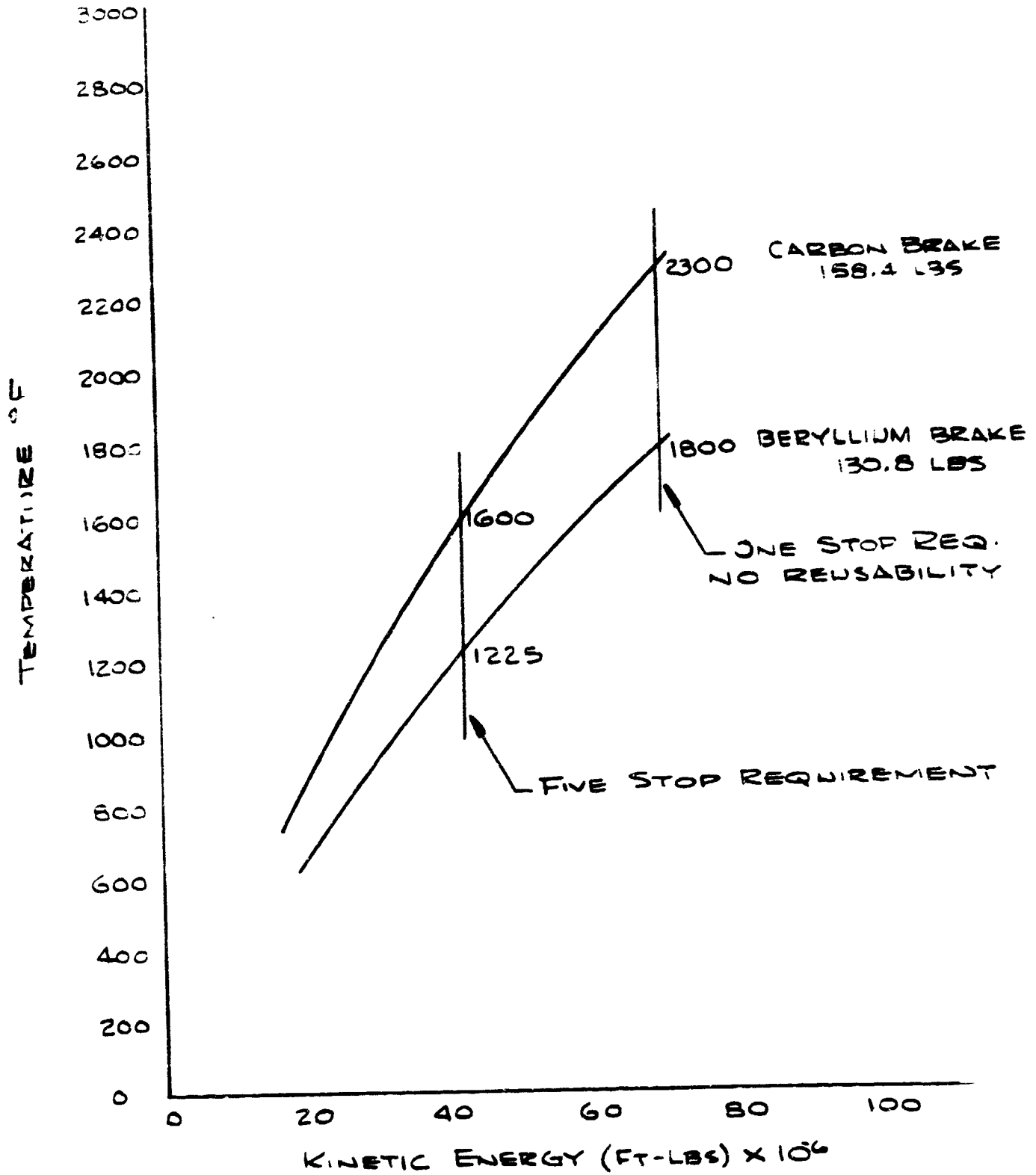

CONCLUSIONS

1. The carbon lined beryllium brake is the lightest brake for the space shuttle requirements.
2. The reuseability and performance of the carbon lined beryllium brake and wheel assembly should exceed that of the structural carbon brake and wheel assembly. The beryllium brake will operate cooler, has the same low wearing lining material as the structural carbon brake and its beryllium core can be relined.
3. The temperature limitations of the wheel and tire limit the full potential of the structural carbon brake. The increase of heat sink weight required for the carbon brake to be compatible with the wheel and tire, make it heavier than the beryllium brake and increase its cost.

RECOMMENDATIONS

The recommendation is to continue the development of the carbon lined beryllium brake. Improvements are required in the thermal conductivity of the carbon lining and the method of attaching the carbon lining material to the beryllium core.

PRECEDING PAGE BLANK NOT FILMED

INTRODUCTION

The object of this investigation was to develop for the space shuttle type requirements, as shown on Table II, a wheel and brake system which would be lighter than existing aircraft wheel and brake designs. The investigation covered development of a lightweight braking system which would be compatible with existing aluminum aircraft wheels.

There were two lightweight aircraft braking systems under consideration. The first used structural carbon as the heat sink material, and the second used carbon or sintered Iron-lined beryllium.

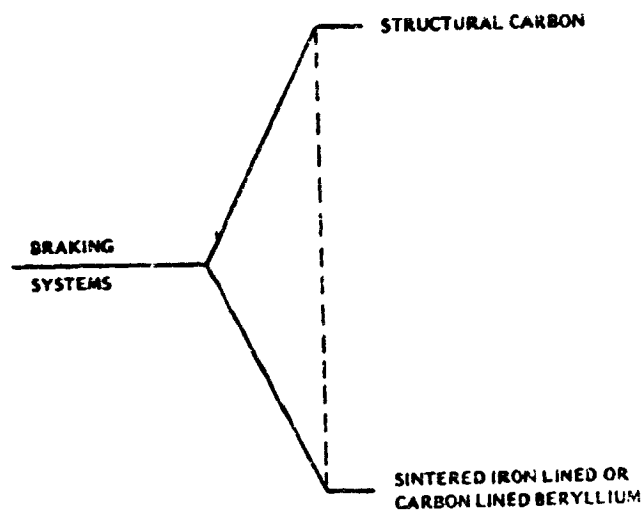

TABLE II

Design Requirements
(Ref: NAS Contract No. 9-12049, Exhibit "A")

Wheel

| | |
|-----------------------|--|
| Tire Type | VII or VIII |
| Rated Static Load | 60,000 lbs. |
| Bottoming Load Factor | 2.8 |
| Inflation Pressure | 300 PSI |
| Touchdown Speed | 180 Knots |
| Tire Size O. D. | 40 to 52 inches |
| Roll Life | 100 Miles |
| Environment | Pressure to 10^{-5} torr. Temperature of -65°F for seven days with a pressure drop not to exceed five percent. |

Brake

One stop $\text{KE} = 100 \times 10^8$ ft-lbs.

STRUCTURAL CARBON HEAT SINK DESCRIPTION

The structural carbon graphite composite heat sink is the industry's most recent development. Figure 1 shows a structural carbon rotor and stator. The design consists of disks with drives on the OD for the rotors and on the ID for the stators with steel reinforcement around each of the drive lugs. Its relative advantages and disadvantages are presented in Table III. It can be seen that carbon brakes have many positive features. The main disadvantage is that it must operate at extremely high temperatures for most applications to be weight-effective with the beryllium brake.

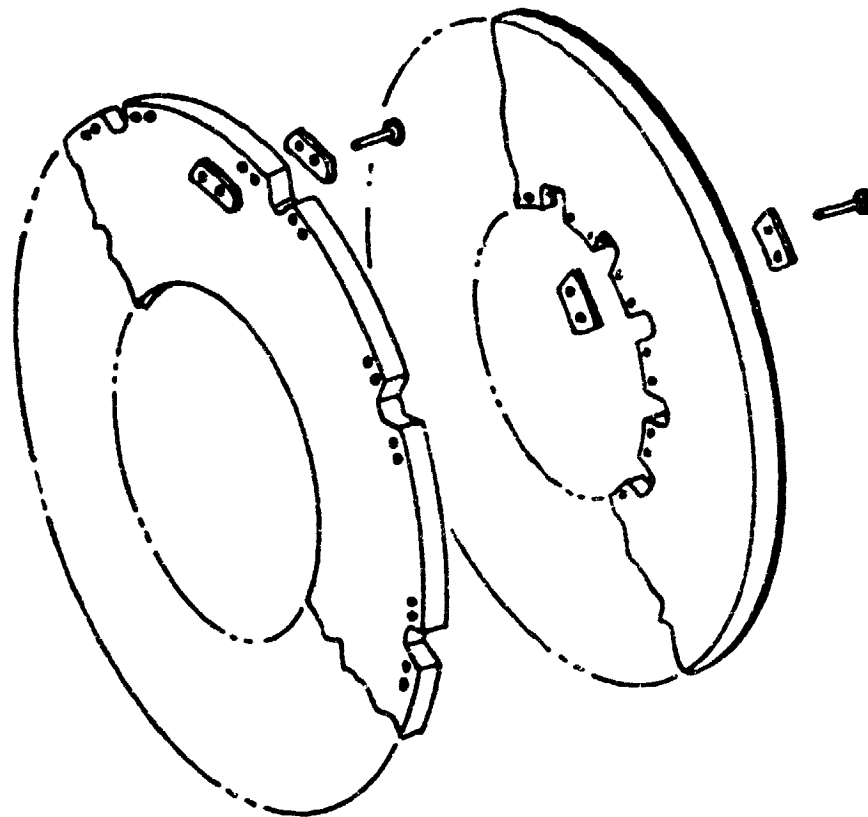

Figure 1

Structural Carbon Rotor and Stator Design

TABLE III

Advantages and Disadvantages of Structural Carbon Heat Sink

| ADVANTAGES | DISADVANTAGES |
|--|---|
| <p>1. <u>Lightweight</u> Depending upon the requirements, the carbon brake could be lighter than the beryllium brake.</p> | <p>1. <u>High Operating Temperature</u> To be weight competitive with the beryllium brake, the carbon heat sink must operate at higher temperatures, thus the temperature of associated hardware will run hotter.</p> |
| <p>2. <u>COST</u> Material costs projected on estimated volume in 1975 are lower than on beryllium.</p> | <p>2. <u>Oxidation</u> Weight and strength loss due to oxidation of the heat sink exists. Oxidation inhibitors have been developed to minimize the problem and give a reasonable heat sink life.</p> |
| <p>3. <u>Wear</u> Present wear rates average ten times lower than the better sintered iron linings. No wear advantage over the carbon-lined beryllium brake.</p> | <p>3. <u>Moisture Sensitivity</u> The coefficient of friction on the early designs was affected by moisture. This condition has been minimized on the latest designs.</p> |
| <p>4. <u>Simplicity</u> The heat sink designs are simply disks with reinforced drives. No attaching of lining required.</p> | |

BERYLLIUM HEAT SINK

The beryllium heat sink has been proven in service on both the C-5A and F-14 aircrafts. Figure 2 shows the carbon-lined beryllium heat sink design, a derivative of the C-5 and F-14 basic design. This derivative uses carbon composites as lining rather than sintered iron with steel backing. The carbon-lined beryllium heat sink combines the frictional advantages of the structural carbon heat sink with the low operating temperatures of the beryllium heat sink. The advantages and disadvantages of the beryllium heat sink are listed on Table IV. The main advantage of using beryllium as a heat sink material is that for equal weight brake assemblies, the beryllium brake would operate cooler than the carbon brake.

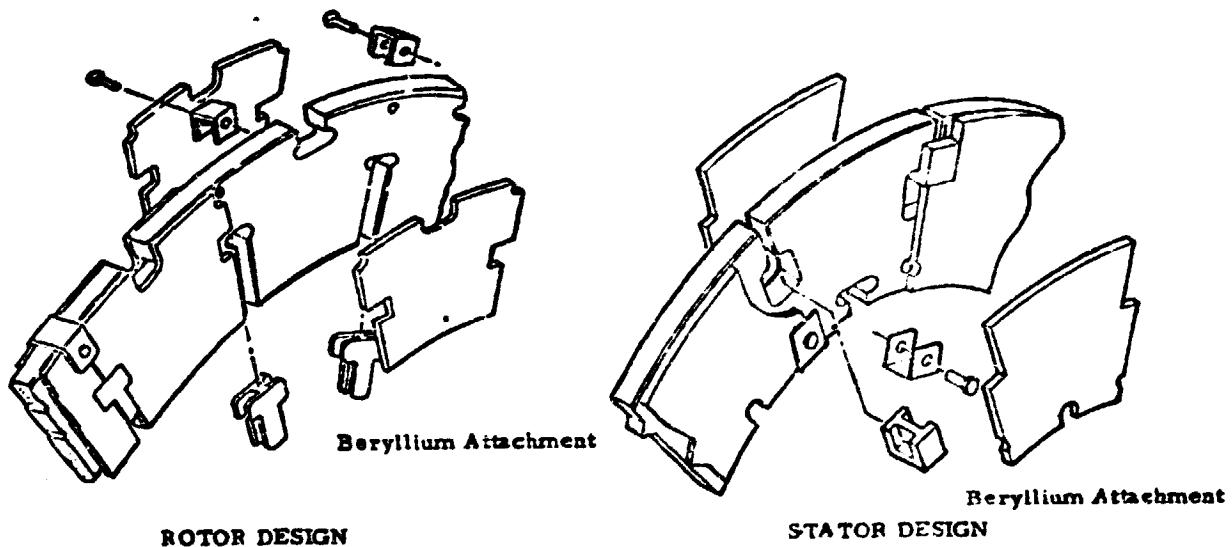

Patent No. 3,746,139
Dated July 17, 1973

Figure 2

BERYLLIUM HEAT SINK (continued)

TABLE IV
Advantages and Disadvantages of Beryllium Heat Sink

| ADVANTAGES | DISADVANTAGES |
|---|---|
| <p>1. <u>Lightweight</u> Depending upon requirements, the beryllium brake could be lighter than the carbon brake.</p> <p>2. <u>Low Operating Temperature</u> Beryllium with its lower heat sink operating temperature results in lower peak temperatures of assembly components such as the piston housing and wheel.</p> <p>3. <u>Replaceable Friction Material</u> Replaceable friction material allows reuse of the beryllium heat sink parts.</p> | <p>1. <u>Cost</u> Depending upon sales volume, costs of the beryllium heat sink are expected to be higher than the carbon heat sink.</p> <p>2. <u>Multiple Components</u> Attachment of lining to the beryllium core produces a number of components.</p> |

PRELIMINARY BRAKE SIZING AND TRADE-OFF

Structural carbon and carbon-lined beryllium brakes were sized for the 100×10^6 ft lbs of energy to operate at the temperature levels shown on Graph No. 3. The brake assemblies shown in Figure 3 and 4 were sized as four-rotor heat sink designs to the parameters shown in Table V.

Existing 727-200 aircraft wheels and piston housings (forged aluminum) were used for development to minimize cost.

GRAPH NO. 3

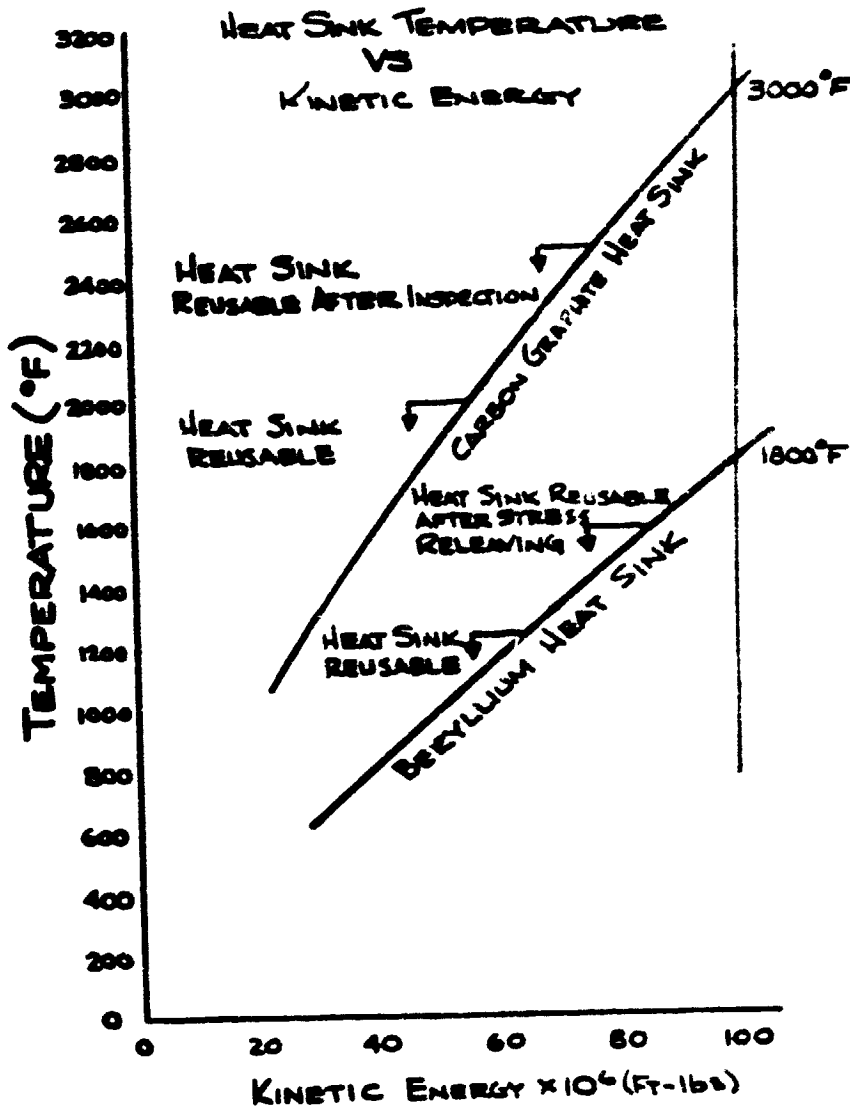

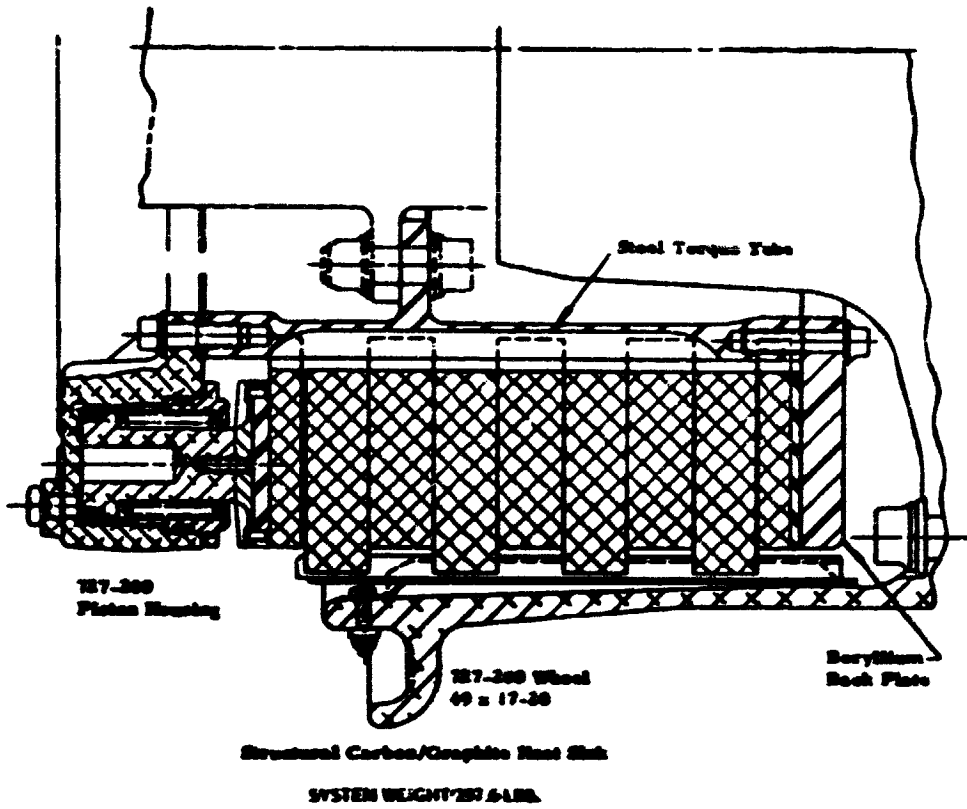

Figure 3

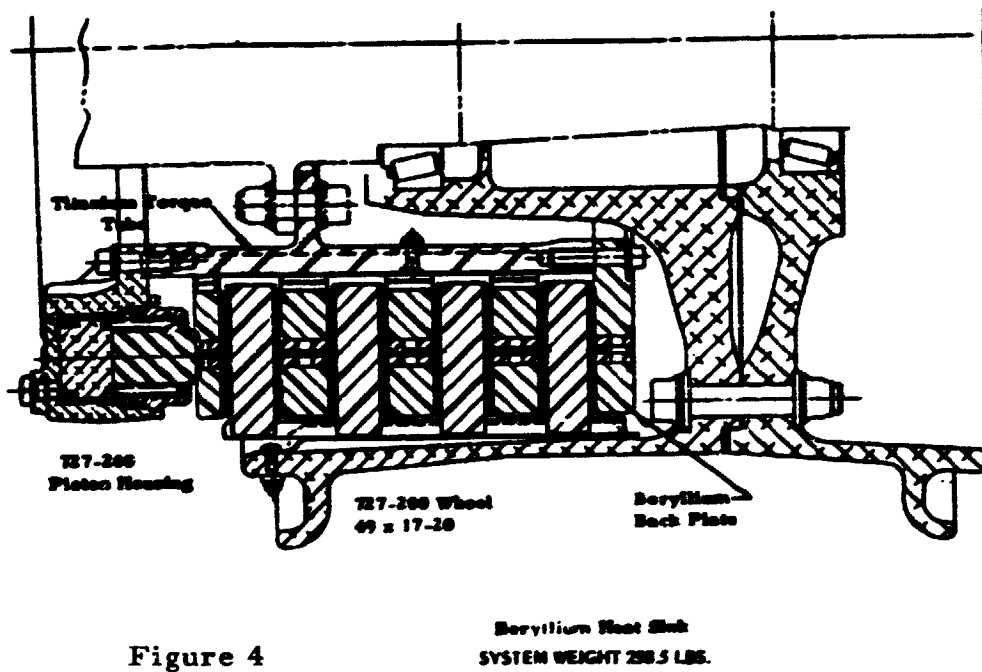

Figure 4

TABLE V
 PROPOSED HEAT SINK CRITERIA

| No. Stops | KE x 10 ⁶ ft lbs | Lining Loading $\frac{\text{ft lbs}}{\text{in}^2}$ | Lining Power $\frac{\text{ft lbs}}{\text{in}^2 \text{ sec}}$ | Friction Force PSI |
|-----------|--------------------------------|---|---|-----------------------|
| 1 | 100 | 83,636 | 2760 | 54.5 |

The object of the development program was to achieve a minimum weight wheel and brake system. The present state of the art was realistically exceeded in sizing these brakes to achieve this goal. The trade-offs between these two wheel and brake systems designed for 100 x 10⁶ ft lbs of energy were as follows:

| | <u>Wheel & Brake Weight - lbs</u> | <u>Peak Heat Sink Temperature °F</u> |
|------------------------------|---|--|
| Structural Carbon Brake | 297.6 | 3000 |
| Carbon-Lined Beryllium Brake | 298.5 | 1800 |

The comparison shows that the carbon brake system, while running considerably hotter, was slightly lighter than the beryllium brake system. The following are areas that need to be investigated for both braking systems.

AREAS OF INVESTIGATION - STRUCTURAL CARBON BRAKE

1. Investigate the high heat sink operating temperature and its effect on and compatibility with the wheel and tire.
2. Determine reusable limits for the wheel and brake assembly.
3. Determine the operating characteristics of the brake, using the proposed design criteria. The design exceeds previous demonstrated design criteria.
4. Determine if the heat sink designed to these conditions can meet the structural requirements.

AREAS OF INVESTIGATION - CARBON-LINED BERYLLIUM BRAKE

1. Determine the operating characteristics of the carbon lining material using the proposed design criteria. The lining loadings exceed previous demonstrated lining loads.
2. Prove method of mechanically attaching the carbon lining to the beryllium core.

PROVEN AREAS

1. The beryllium heat sink has been proven structurally by C-5A and F-14 aircraft applications. The internal stresses of the proposed beryllium heat sink are approximately 25% lower than the proven capability of the C-5 A beryllium heat sink. Reference: Stress Analysis in Appendix B, pages B-1 through B-4.
2. The lower operating temperature of beryllium heat sink has been proven compatible with the tire and aluminum wheel.

ER-4239
FSC 97153
Part III

PROVEN AREAS (continued)

The structural carbon brake was selected for the initial development effort. To realize the potential cost and weight savings of the carbon brake, the effort was required to provide information regarding the feasibility of using the carbon heat sink.

The heat sink material selected for the program was a CVD (chemical vapor deposited) processed rayon material manufactured by Super Temp Co., Santa Fe Springs, California. The material was selected for its high mechanical properties.

PROGRAM PLAN

The development program on the structural carbon brake was divided into two phases:

PHASE I

Phase I develops the design criteria and limitation of the structural carbon heat sink. Phase I consisted of testing two, two-rotor heat sinks. The first two-rotor heat sink would be tested to determine the maximum heat sink loading that the heat sink will withstand and still be reusable. This would be accomplished by running stops, increasing the heat sink loading, and inspecting until failure or serious deterioration occurs.

The second two-rotor heat sink would be tested to determine the maximum heat sink loading for a one-stop condition. The maximum heat sink loading will be determined by the amount of energy absorbed by the brake at time of failure.

PHASE II

Phase II combines the technology generated in Phase I into a practical lightweight wheel and brake sub-system concept for the space shuttle type requirements. The final test would be to run a full-size brake to the one-stop energy condition.

ER-4239
FSC 97153
Part III

PHASE I
TWO-ROTOR BRAKE TEST

Assembly P/N 2-1279

OBJECTIVE

1. Establish reusable limits for heat sink.
2. Verify design criteria for high-temperature operation.

TEST RESULTS

The objective was accomplished. The stop was completed at a heat sink loading of 850, 700 ft lbs/lbm; equivalent to 2,680°F. The following conclusions were made:

1. The heat sink is not reusable at a heat sink loading of 850,000 ft lb/lbm. The high temperatures generated caused localized oxidation, making the heat sink unsafe for reuse. The reusable limit established previously on military applications would still hold for the Space Shuttle at a heat sink loading of 550,000 ft lb/lbm.
2. A weight reduction of approximately five percent can be realized by eliminating the steel reinforcing clips around the drive lugs. These clips were designed to eliminate abrasion on the faces of the drive lugs for long-life application. The high operating temperature for the one-stop condition weakens the steel clips, and the life requirements for the Space Shuttle do not require clips for abrasive protection.
3. Coefficient of friction was low. A four-rotor brake was proposed for this development program to optimize weight. This meant pushing the lining power far beyond the present state-of-the-art. This high lining power generated extreme surface temperature causing the low coefficient of friction. As the lining power dropped during the stop, the coefficient of friction recovered.

TEST RESULTS (continued)

3. (continued)

The solution to the problem would be to increase the number of rotors decreasing the lining power. Since the reinforcing clips are no longer required, there will be no weight penalty for increasing the number of rotors.

Graph No. 4, page 14, shows torque and temperature versus stop time. The numbers 1 and 2 rotor temperatures (R-1, R-2) were measured on the outside diameter. The stator temperatures shown were measured at the inside diameter of the center stator as shown in Figure 5.

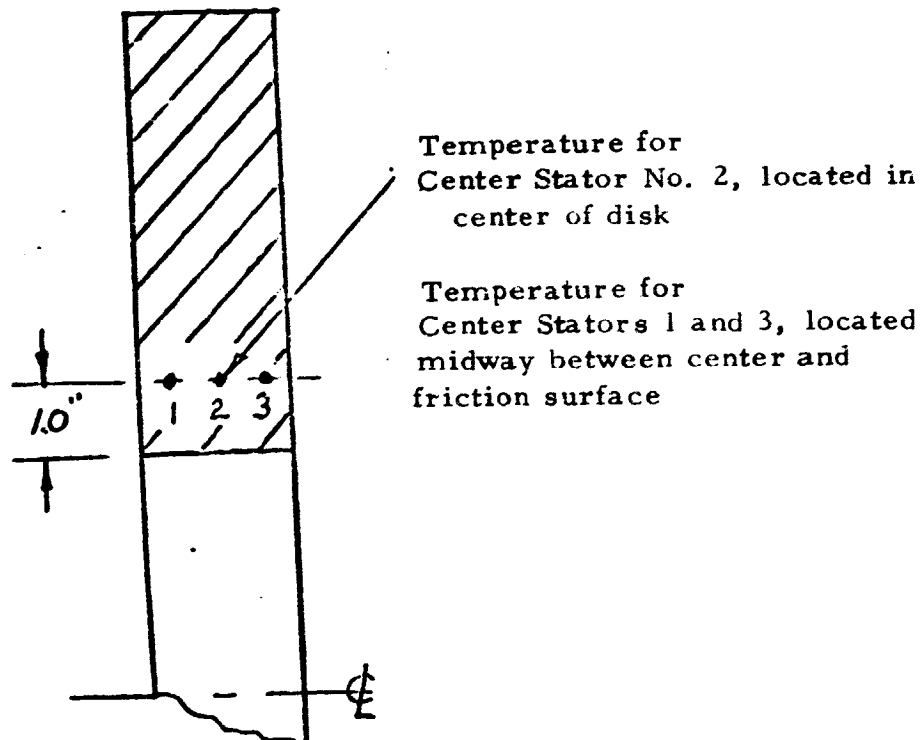

Temperature for
Center Stator No. 2, located in
center of disk

Temperature for
Center Stators 1 and 3, located
midway between center and
friction surface

Center Stator
Fig. 5

ER-4239
FSC 97153
Part III

TEST RESULTS (continued)

The stator thermocouples burned out at about 2,200°F. These thermocouples showed a temperature gradient of 4,700°F/In in the beginning of the stop between Positions 1 and 2. The temperature gradient between the friction surfaces and thermocouples, Positions 1 and 3, is expected to be higher than 4,700°F/In.

GRAPH NO. 4

PHASE I
TWO-ROTOR BRAKE TEST

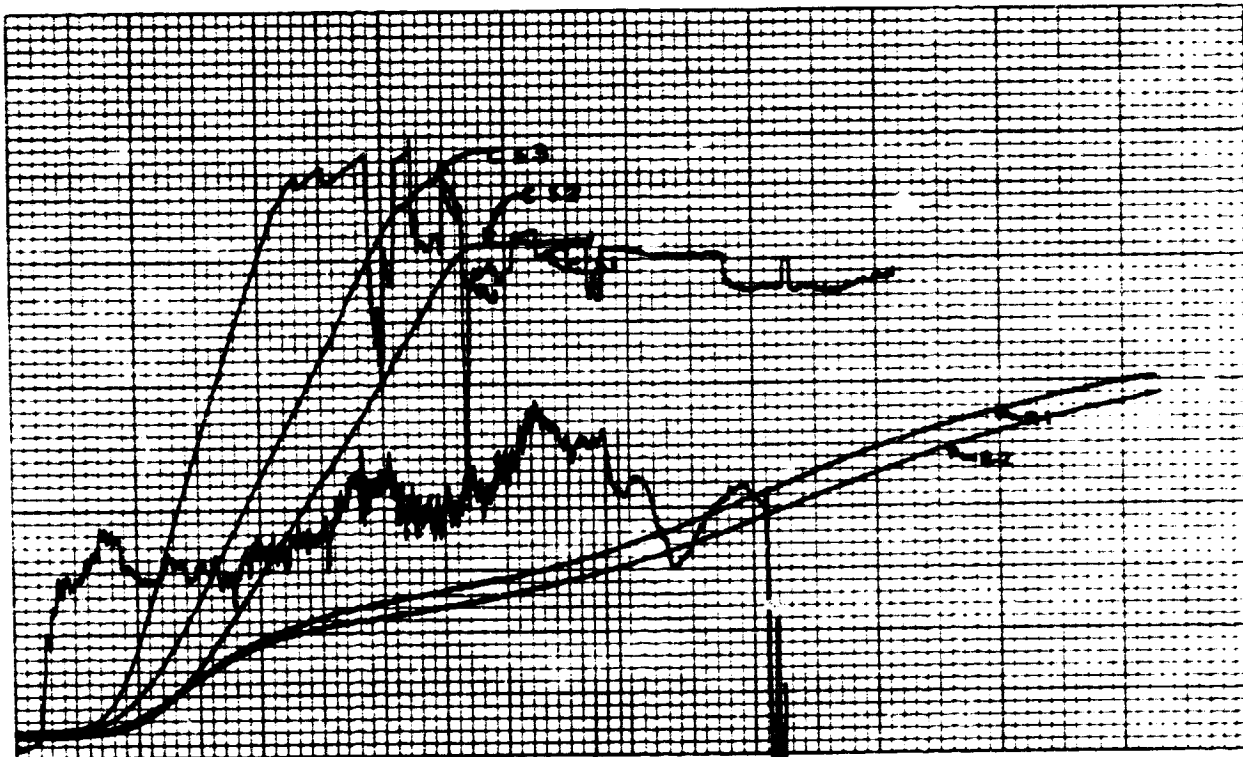

TEST NO. 3822 SPEED 261.8 PRESS/IN _____ T.W./IN _____ TEMP/IN 500°F _____ /IN _____
RUN NO. 6 STOP TIME 59.5 TORQUE/IN 5000 LB. FT./IN _____ /IN _____ /IN _____
DATE 7-17-72 DISTANCE 9746.8 R.W./IN _____ E_v/IN _____ /IN _____ TIME/IN 10 SEC

ER-4239
FSC 97153
Part III

TEST RESULTS (continued)

Graph No. 5 shows the temperature survey of the structural components surrounding the two rotor heat sinks. The temperature survey was performed with cooling fan blowing into wheel from the outboard side. The peak temperature of the wheel tubewell exceeded its reusable limit, and the fuse plug released the tire inflation pressure. The test verified that the wheel would not be reusable at a brake kinetic energy of 39.06×10^6 ft lb and a heat sink temperature of 2680°F .

Danger exists in operating the maximum energy condition of 100×10^6 ft lbs at these temperatures in that without external cooling, the tubewell of the wheel could fail before the fuse plugs can deflate the tire.

Photographs 1 through 4 show the heat sink before and after test.

GRAPH NO 5
TEMPERATURE SURVEY
TWO-ROTOR BRAKE TEST

PHASE I TWO ROTOR TEST
KE = 39.06×10^6 FT-LBS
HSL = 840,000 FT-LBS/LB
TEMPERATURE 2680°F

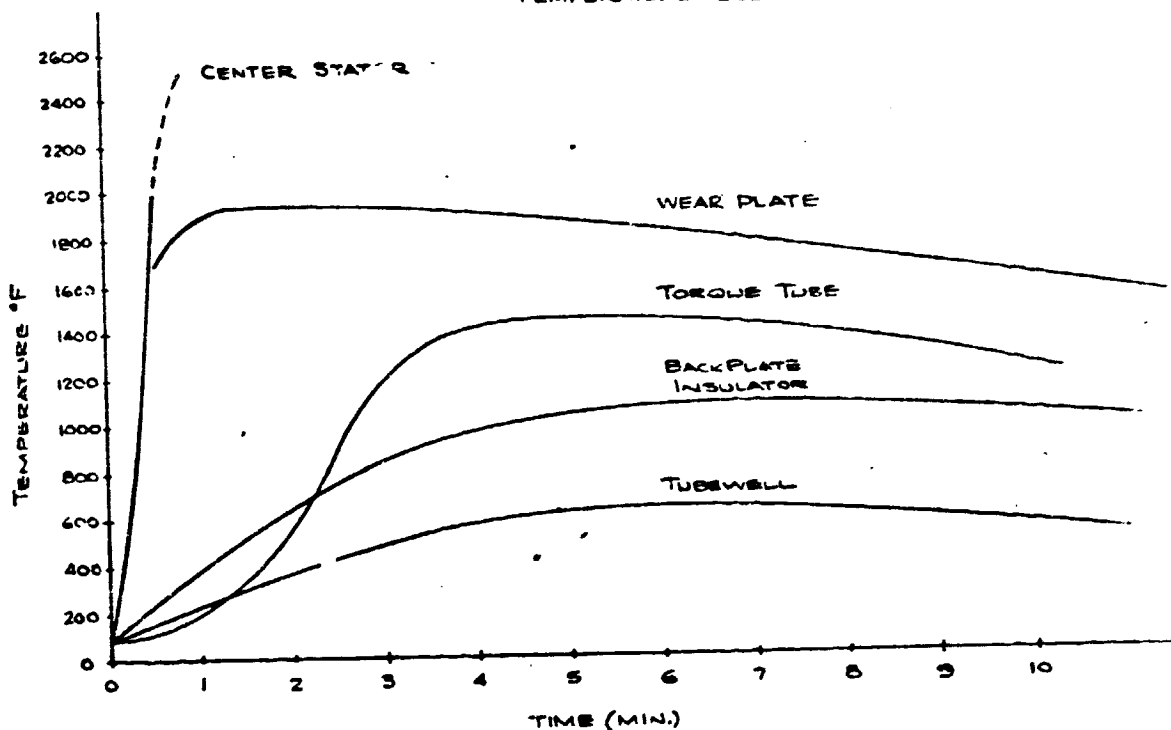

ER-4239
FSC 97153
Part III



PHOTOGRAPH NO. 1

NEW HEAT SINK

ER-4239
FSC 97153
Part III

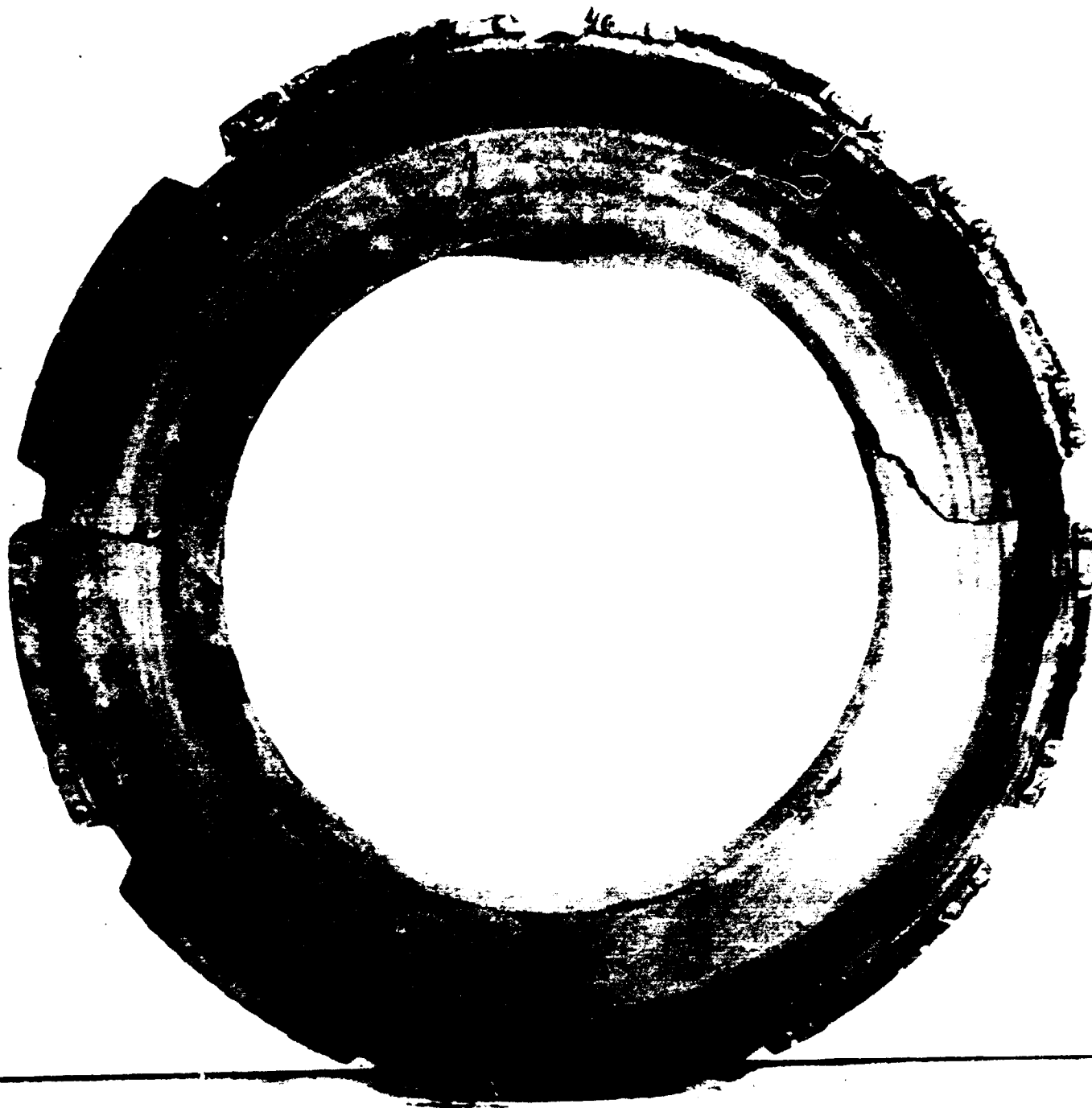

PHOTOGRAPH NO. 2

ROTOR AFTER TEST SHOWING THERMAL CRACKING

ER-
FS

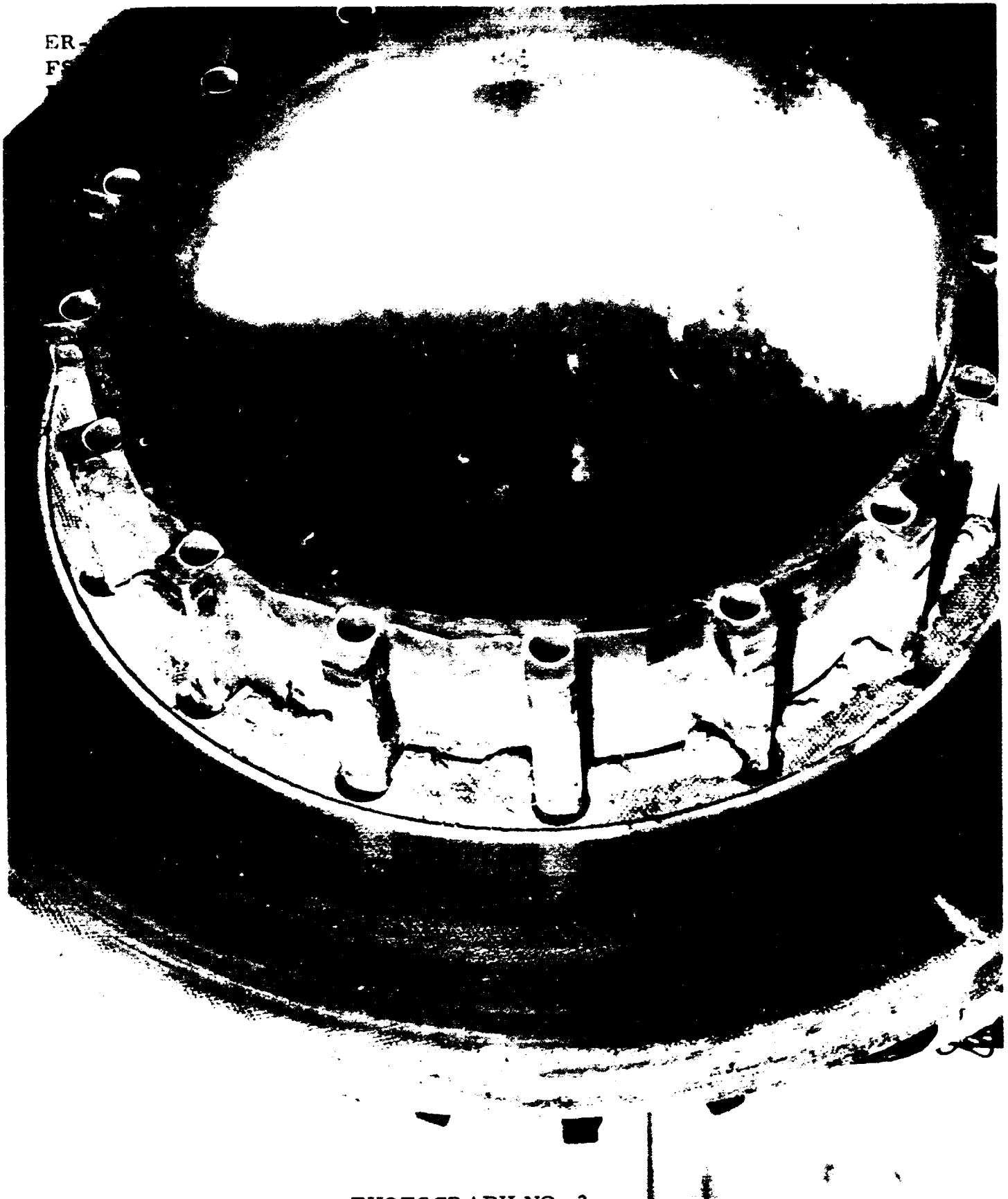

PHOTOGRAPH NO. 3

CENTER STAGE, 24 IN. TORQUE TUBE
NOTE REINFORCING CLIPS USED TO TORQUE TUBE

ER-4239
FSC 97153
Part III

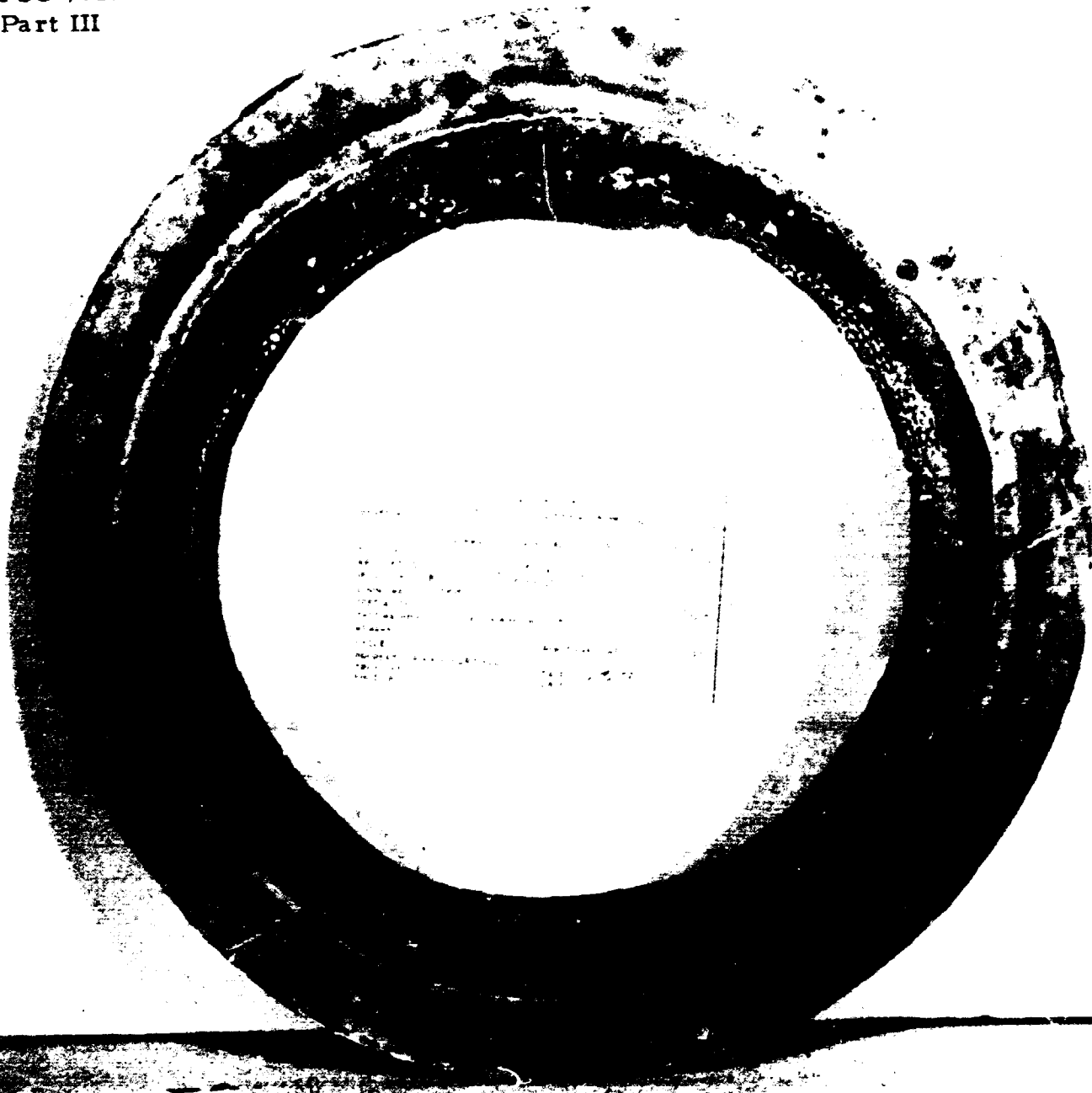

PHOTOGRAPH NO. 4

BACK PLATE INSULATOR

Temperature Data Indicated that the Insulator Performed its function. The Hastelloy X Material Melted After the Stop

PROBLEM AREAS

FABRICATION

The four-rotor heat sink presented a processing problem due to the thickness of the parts. The rotor and stator thicknesses were 1.207 and 1.289 inches, respectively.

One limitation of the CVD processing system is the difficulty of infiltrating thick structures. Pyrolytic carbon is built on all exposed fibers simultaneously. The space between the outer fibers is gradually sealed off with further infiltration of the interior of the structure being stopped. So, great care is required to prevent premature sealing of the outside surfaces.

The problem with the thick parts is obtaining a high-density core. By reducing the thickness of the heat sink elements, the required penetration depth is decreased; increasing the density of the core. Figure 6 shows the relative improvement in density.

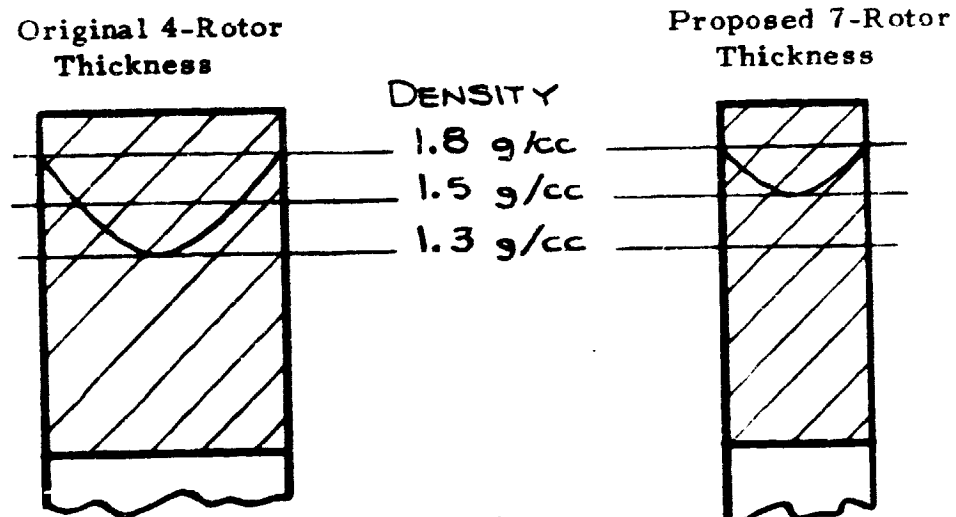

Figure 6

Increasing the density also improves the strength and thermal conductivity of the material; two important factors.

THERMAL STRESS

The dynamometer test results indicated high temperature gradients across the thickness of the disk. An analytical study was performed using the computer to determine the temperature gradients and corresponding thermal stress for a four-rotor and seven-rotor brake. The thermal stress computed for the present four-rotor configuration was 11,900 psi. This stress level is equivalent to the ultimate tensile strength of the material, substantiating the failures observed on test.

A similar analysis was performed on the proposed seven-rotor brake for Phase II with the following changes.

1. The change from four rotors to seven rotors decreased the lining power or heat flux to 4/7 of the four-rotor configuration.
2. The change in thickness by going to a seven-rotor brake improves the density, strength, and thermal conductivity across the thickness. The seven-rotor brake was heat treated, increasing its thermal conductivity to 2.5 times that of the four-rotor brake configuration tested in Phase I.

Graph No. 6 shows the comparison of the temperature gradients between the four and seven-rotor brake. The thermal stresses calculated for the seven-rotor brake were 2,570 psi compared to 11,900 psi for the four-rotor. This is a decrease in thermal stress of 78 percent.

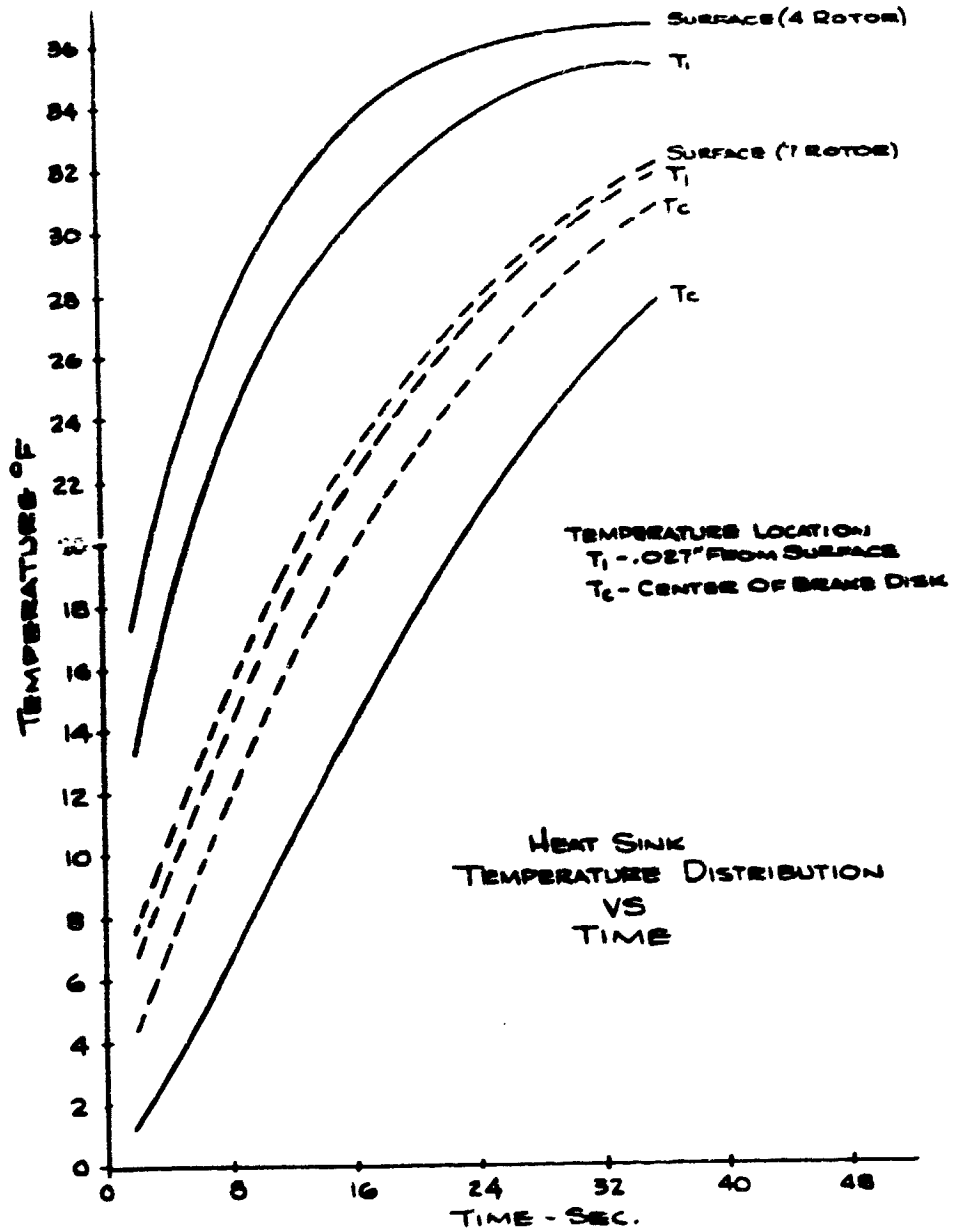

GRAPH NO. 6
COMPARISON OF DISK TEMPERATURE
DISTRIBUTION BETWEEN A 4 & 7-ROTOR HEAT SINK

PHASE II

FINAL DESIGN AND TEST

Phase I test indicated that the full capability of the carbon heat sink could not be utilized at energy levels required by the space shuttle, due to the temperature limitations of the wheel and tire. This limitation could cause the carbon brake to have a severe weight penalty compared to the carbon lined beryllium brake. To obtain the lightest configuration, B. F. Goodrich proposed at this time to evaluate both structural carbon and carbon lined beryllium to the actual space shuttle requirements. The proposal was excepted and the contract redirected to evaluate both brake designs to the following requirements: REF: NAS 9-12049, Exhibit "A", Amendment 4S.

SPACE SHUTTLE REQUIREMENTS
(10-16-72)

1. REUSABLE ENERGY CONDITION
 - A) 5 Stops
 - B) $KE=42 \times 10^6$ ft lbs
 - C) Brake on Speed 190 Knots
 - D) Deceleration 10 ft/sec^2

2. MAXIMUM ENERGY CONDITION
 - A) 1 Stop
 - B) $KE=70 \times 10^6$ ft lbs
 - C) Brake on Speed 190 Knots
 - D) Deceleration 10 ft/sec^2

Structural carbon and carbon lined beryllium brakes were sized for the space shuttle requirements. The structural carbon brake was sized by the 5-stop requirement, operating at 2000°F. The beryllium brake was sized by the maximum energy requirement, operating at 1800°F.

Graph No. 7 shows the heat sink temperature vs kinetic energy, and Table VI shows the weight comparison for the brake designs in Figures 7 and 8.

GRAPH NO. 7

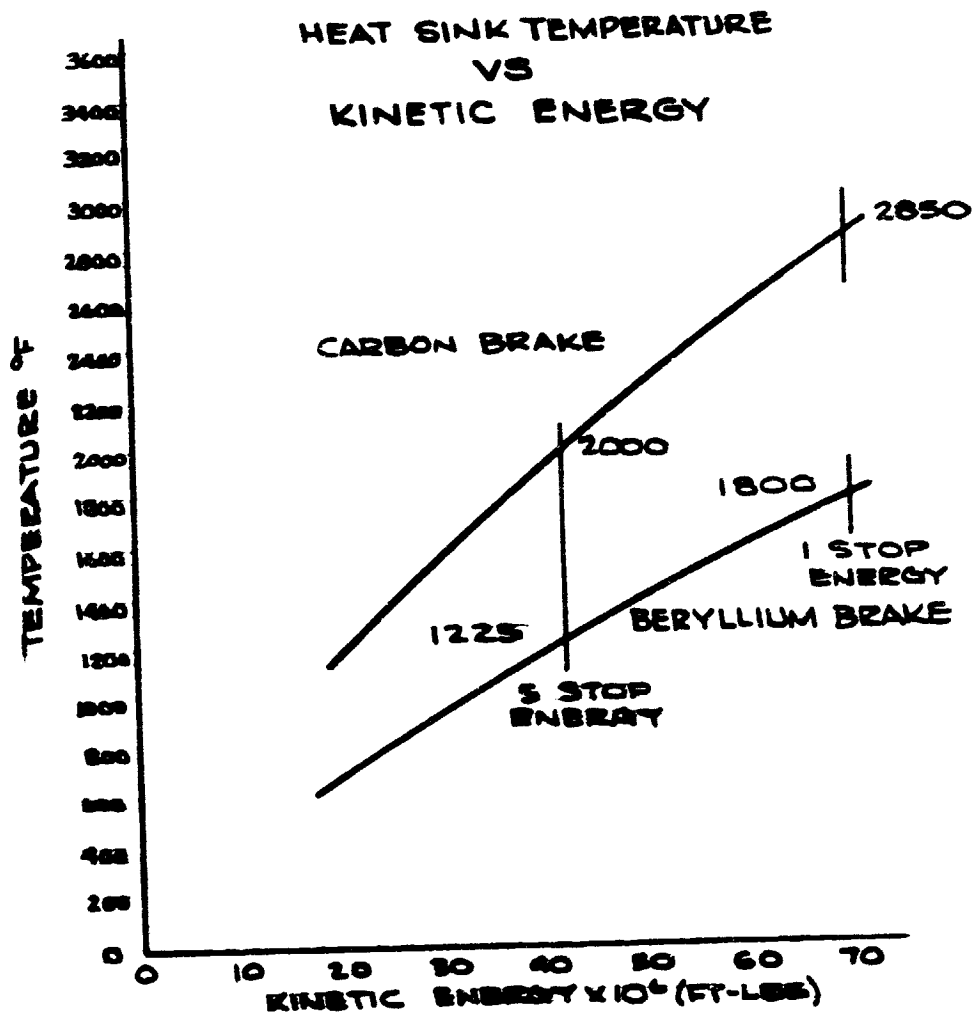

ER-4239
FSC 97153
Part III

TABLE VI
WEIGHT COMPARISON

| | 5-Rotor Structural Carbon | 5-Rotor Carbon Lined Beryllium Steel Attachment |
|-------------------------|---------------------------|---|
| Rotors | 34.5 | 43.4 |
| Stators | 27.6 | 34.7 |
| Wear Plates | 6.9 | 4.5 |
| Beryllium Back Plate | 7.7 | 9.1 |
| Torque Tube | 24.2 | 13.6 |
| Piston Housing Assembly | 23.4 | 20.3 |
| Insulation | 1.8 | --- |
| Wheel Assembly | 151.3 | 149.3 |
| Total | 277.4 | 274.9 |

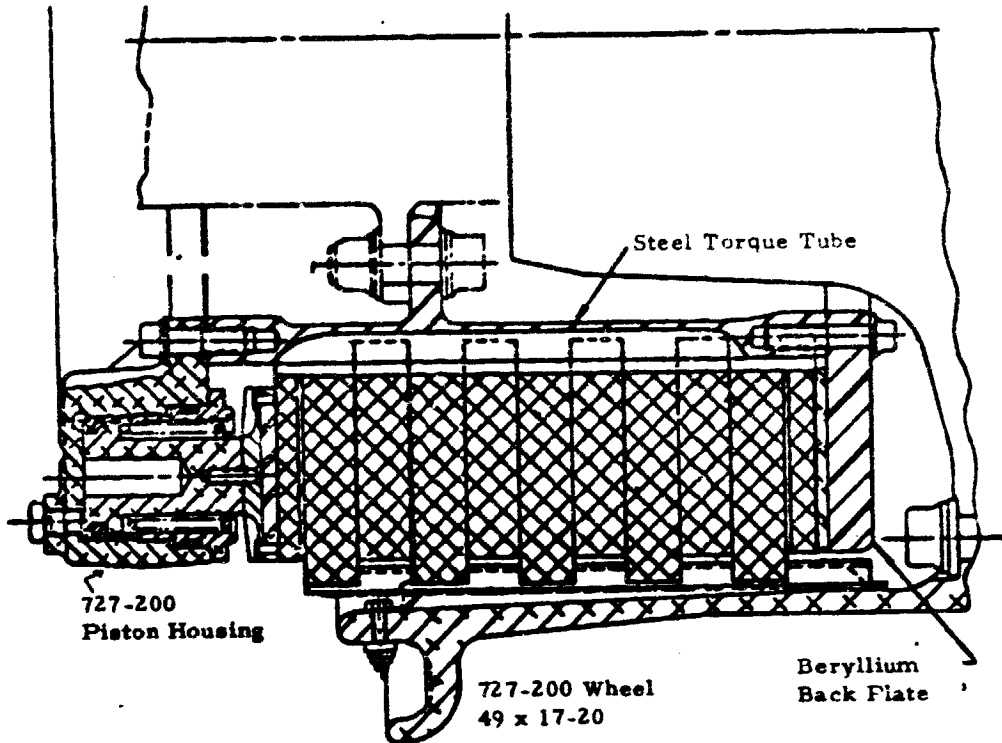

Structural Carbon/Graphite Heat Sink
P/N 2-1279-2

Figure 7

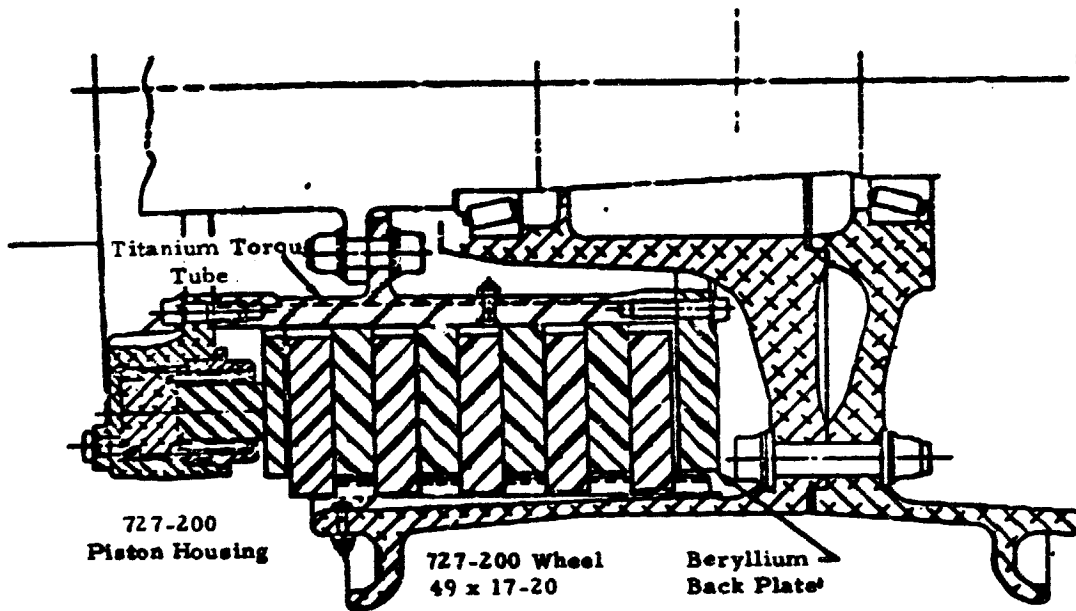

P/N 2-1279-3

Beryllium Heat Sink

Figure 8

PROGRAM DESCRIPTION

Two parallel programs, as shown by the flow chart, were used to evaluate the braking systems. The objectives were:

- A. To demonstrate the heat sink design criteria.
- B. To prove that the heat sink structural capabilities will meet the requirements.
- C. To prove wheel, tire, and brake compatibility.

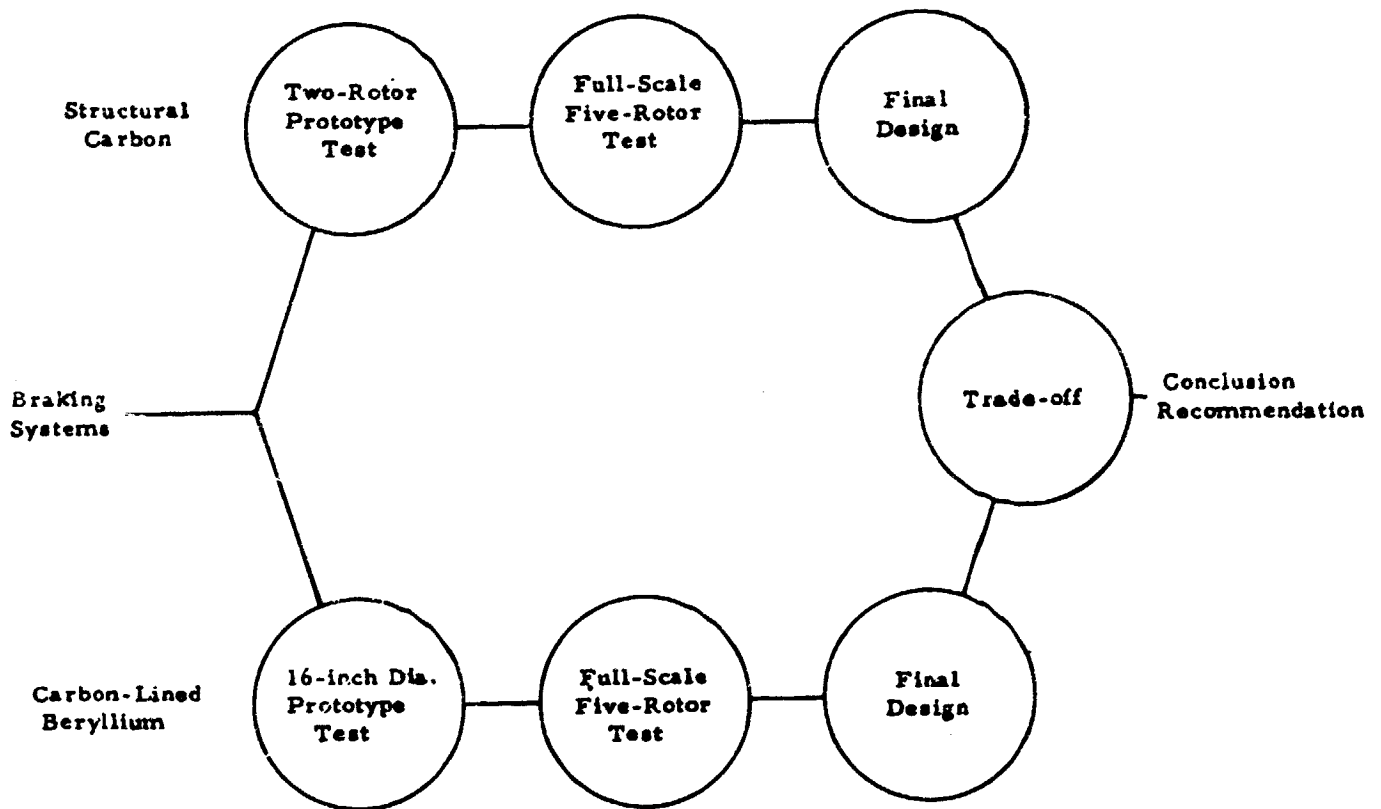

ER-4239
 FSC 97153
 Part III

STRUCTURAL CARBON PROTOTYPE TEST
 TWO-ROTOR BRAKE

The prototype test was performed on a two-rotor brake to the equivalent space shuttle normal energy (5-Stop requirement) and the maximum energy (1-Stop requirement). Table VII lists the two-rotor brake requirements and the average results from the test.

TABLE VII
 CARBON BRAKE
 TWO ROTOR TEST RESULTS

| PARAMETER | REQUIREMENTS | | AVERAGE RESULTS | |
|---|---------------|----------------|-----------------|----------------|
| | NORMAL ENERGY | MAXIMUM ENERGY | NORMAL ENERGY | MAXIMUM ENERGY |
| NUMBER STOPS | 5 | 1 | 6 | 1 |
| KINETIC ENERGY (FT-LBS) x 10 ⁶ | 14.7 | 24.4 | 14.65 | 24.53 |
| INERTIA EQUIVALENT (LBS) | 10,391 | 16,928 | 10,391 | 16,928 |
| LANDING VELOCITY FPS | 302.0 | 305.0 | 301.0 | 305.2 |
| STOP TIME (SEC) | 31.0 | 31.0 | 33.8 | 33.3 |
| BRAKE TORQUE (FT-LBS) | 5112 | 8414 | AVG 4693 | AVG 7869 |
| | | | PEAK 6200 | PEAK 12,500 |
| LINING LOADING (FT-LBS/IN ²) | 24,054 | 39,937 | 23,972 | 40,140 |
| LINING POWER (FT-LBS/SEC-IN ²) | 775.9 | 1287.9 | 709.0 | 1205.4 |
| FRICTION FORCE (PSI) | 15.5 | 25.5 | AVG 14.2 | 23.8 |
| | | | PEAK 18.9 | 37.8 |
| TEMPERATURE °F | 1980°F | 2810°F | 1970°F | |
| HEAT SINK LOADING FT-LBS/LB _M | 548,507 | 910,447 | 546,641 | 915,298 |

ER-4239
FSC 97153
Part III

A crack was observed in the stator after the first normal stop, as shown by Photograph No. 5. The crack originated in the drive notch and was believed to be due to combination of mechanical and thermal stresses. The drive configuration was modified to reduce the stress concentration as shown by Photograph No. 6.

Five normal stops and one maximum stop were completed on the modified stator with no cracking. Cracks were observed in the rotors during the normal stops, but the tests were completed with no apparent problems. Photographs numbered 7 through 9 show the condition of the heat sink after testing.

The torque characteristics for the high-temperature operation are shown on Graphs numbered 8 and 9. The coefficient of friction averages 0.14 for the normal stop and .085 for the maximum energy stop. Colored movies (*) of the stops indicate the severity of operating the heat sink at these high temperatures and pinpoint a potential wheel and tire compatibility problem. The high kinetic energy proposed for the wheel and brake package will limit the temperature at which the heat sink can operate and be compatible with the wheel and tire.

(*) Movie No. A-135, showing fifth normal and maximum energy stop supplied to NASA Manned Spacecraft Center, Mechanical Systems Branch, Houston, Texas; Attention: J. E. Martin. Marked for Contract NAS-9-12049.

ER-4239
FSC 97153
Part III



PHOTOGRAPH NO. 5

CENTER STATOR SHOWING CRACK IN DRIVE LUG AREA
AFTER THE FIRST NORMAL STOP

ER-4239
FSC 97153
Part III

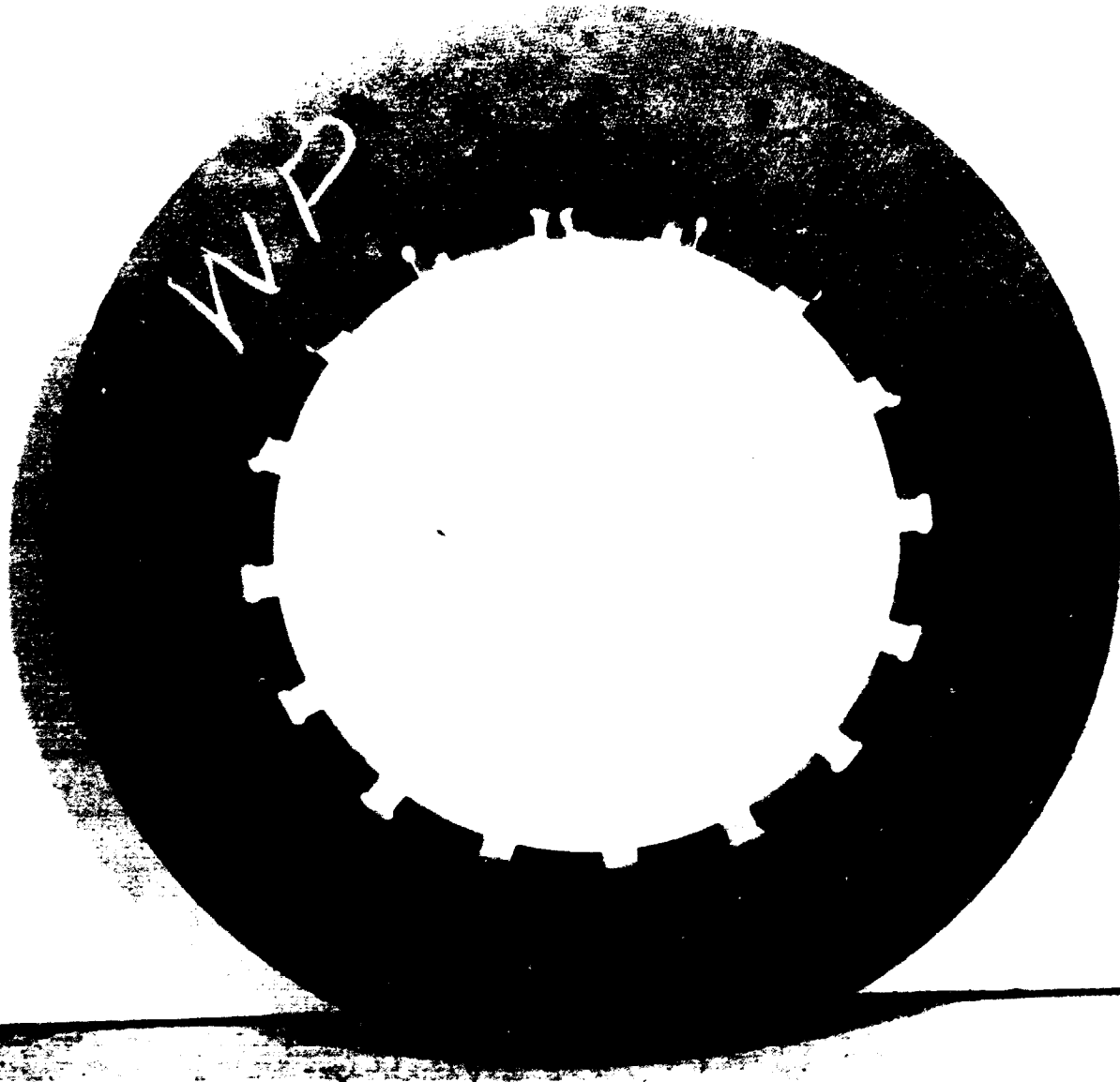

PHOTOGRAPH NO. 6

CENTER STATOR
Showing Drive Lug Modification Reducing the Stress Concentration

ER-4239
FSC 97153
Part III



PHOTOGRAPH NO. 7
HEAT SINK CONDITION AFTER TEST
to Normal Stops Maximum Energy Stop

ER-4239
FSC 97153
Part III

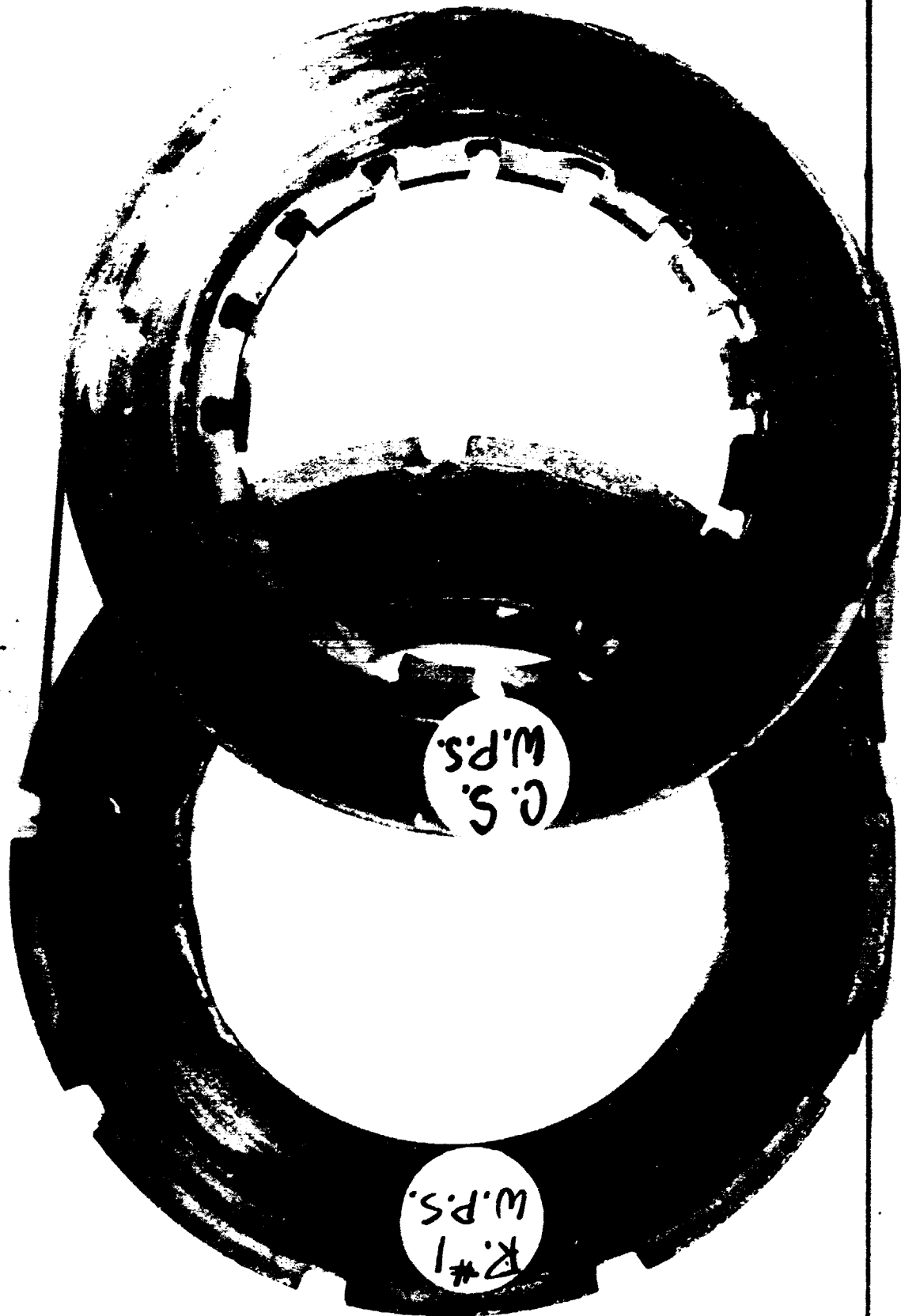

PHOTOGRAPH NO. 8

STATOR AND ROTOR CONDITION AFTER TEST

ER-4239
FSC 97153
Part III

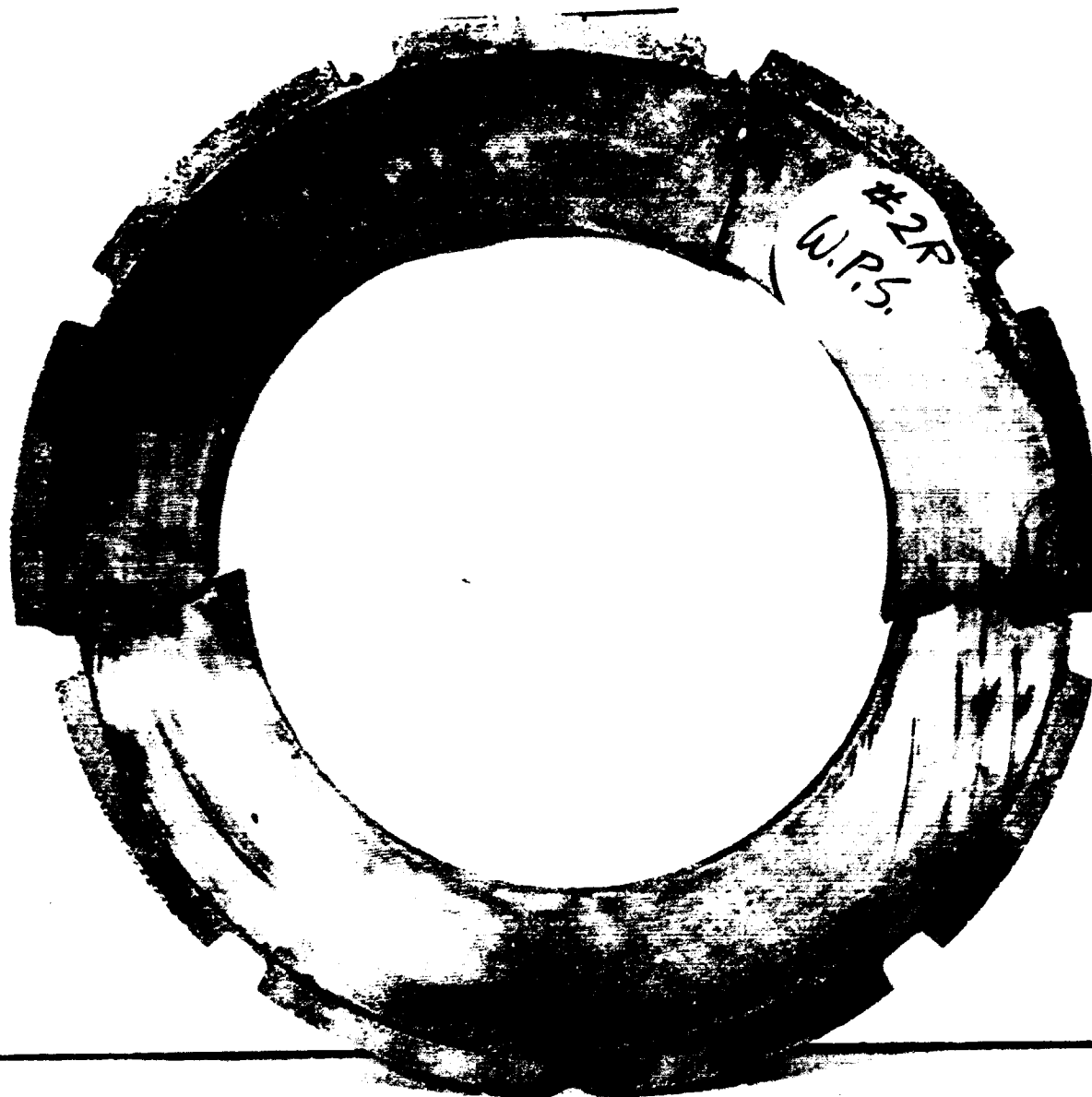

34

NO. 2 ROTOR CONDITION AFTER TEST

ER-4239
 FSC 97153
 Part III

B.F. GOODRICH AEROSPACE & DEFENSE PRODUCTS
 Wheel and Brake Plant Troy, Ohio

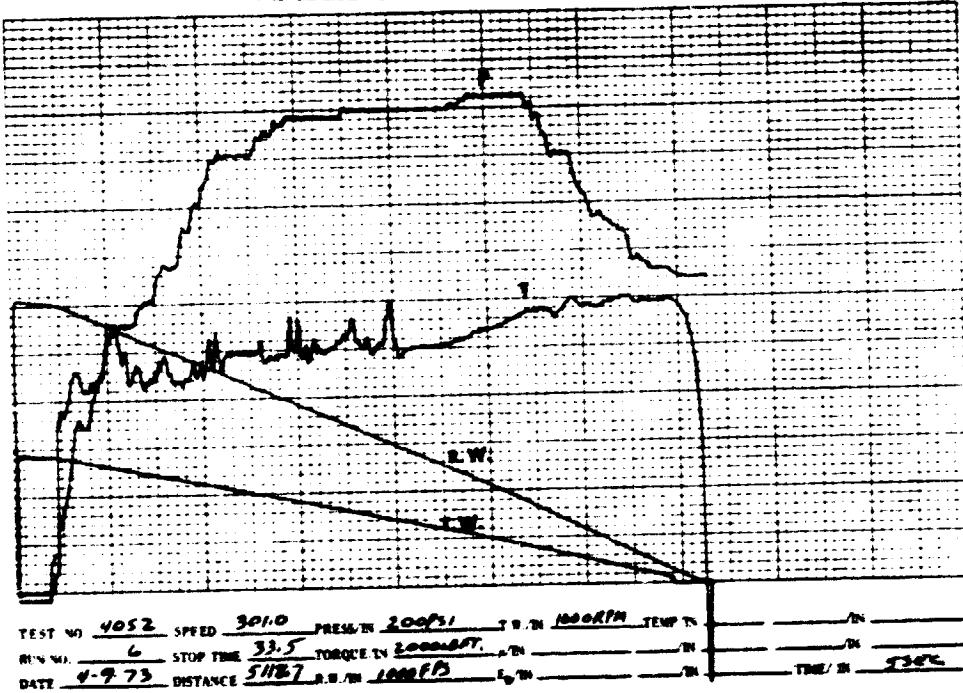

Graph No. 8
 Pressure, Torque VS Stop Time -- Normal Energy

B.F. GOODRICH AEROSPACE & DEFENSE PRODUCTS
 Wheel and Brake Plant Troy, Ohio

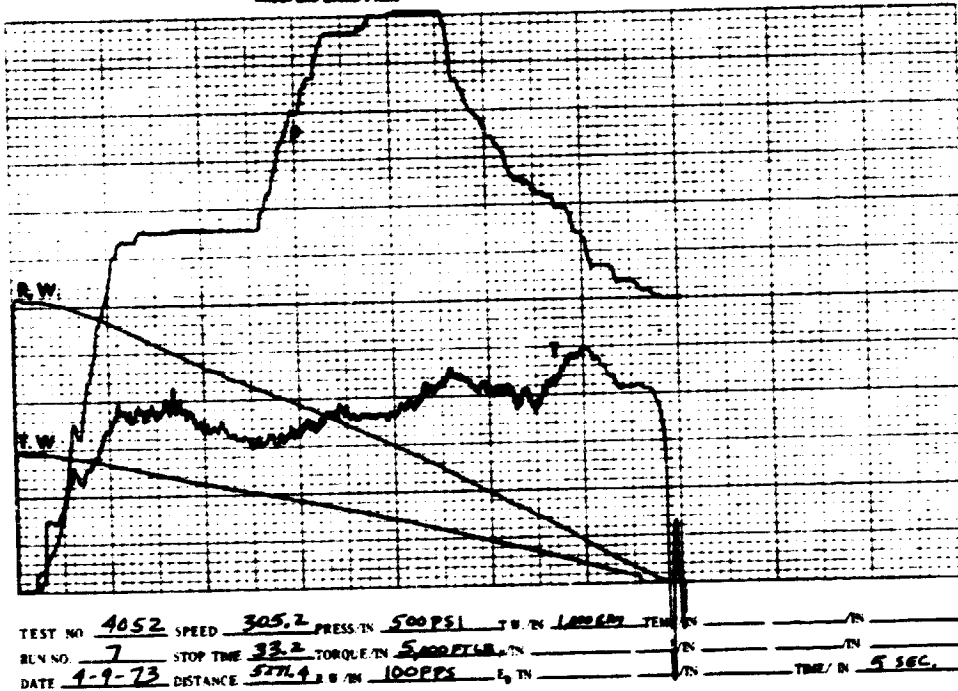

Graph No. 9
 Pressure, Torque VS Stop Time -- Maximum Energy

STRUCTURAL CARBON
FIVE-ROTOR BRAKE TEST

OBJECTIVE

- A. To prove the full heat sink capability.
- B. To prove the wheel and tire compatibility.

An attempt was made to test a full-size structural carbon brake to the space shuttle five-stop condition, operating at 2000°F and a one-stop condition, operating at 2850°F. During the initial testing, the No. 4 stator failed as shown by Photograph No. 10. Cause of the failure was believed due to a combination of mechanical and thermal stress and the unequal distribution of load throughout the heat sink. The thermal stress was believed to be the major cause of failure, as theoretical stress analysis showed that the mechanical loads on the stator were running approximately four percent of the ultimate strength of the material.¹ The wear of this material is very low, causing non-uniform contact across the face of this disk. The thermal conductivity of the material is low, and the localized contact areas caused hot bands producing high thermal stresses. Hot bands on the outside diameter of the stator put the inside diameter in tension which, with mechanical stresses, caused failure.

Photograph Nos. 11 and 12 show the rotor and stators after test.

¹ Appendix A, Carbon Brake Failure Analysis

ER-4239
FSC 97153
Part III



PHOTOGRAPH NO. 10
NO. 4 STATOR AFTER INITIAL TESTING

IR-4239
FSC 97153
Part III

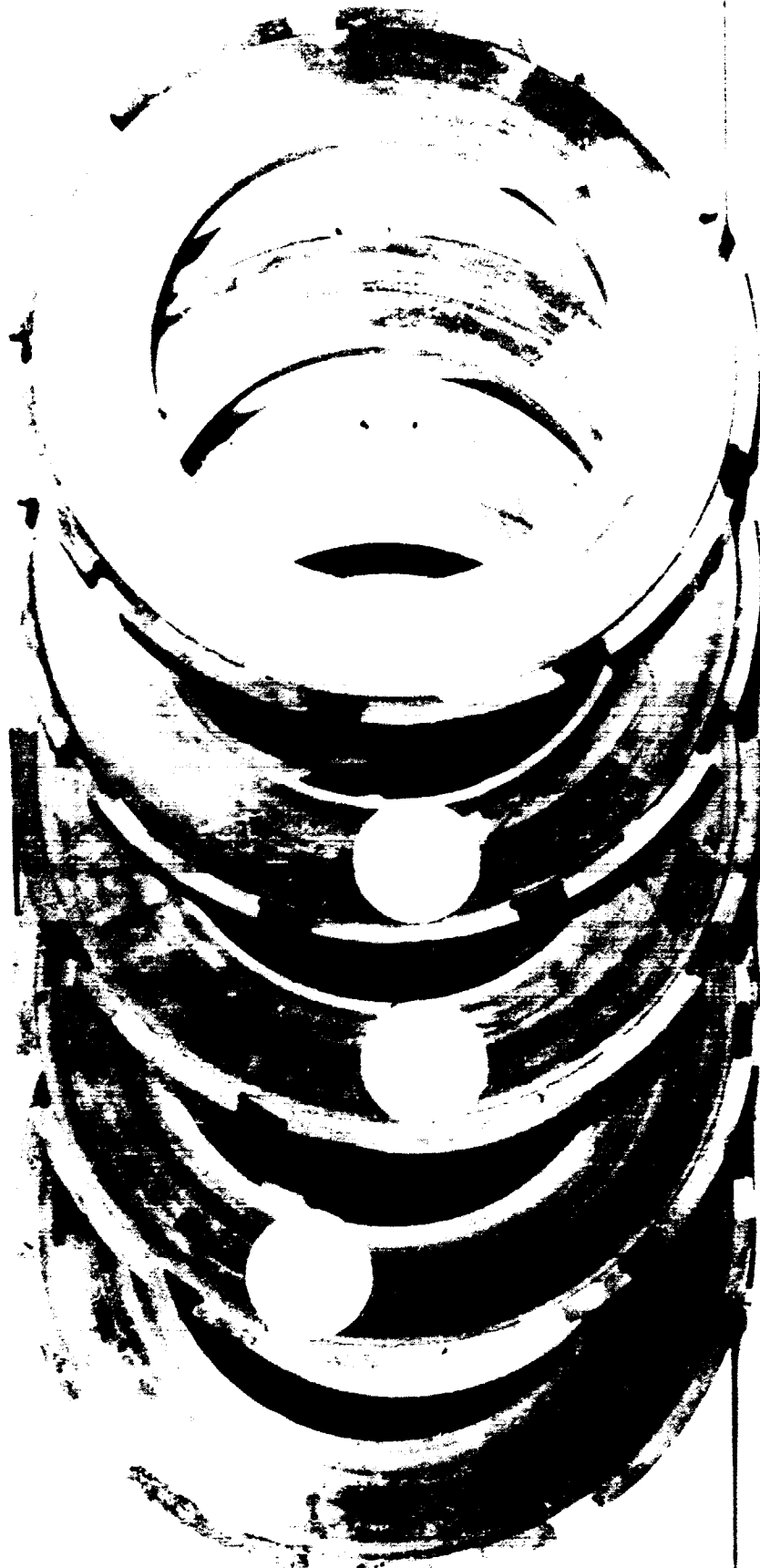

PHOTOGRAPH NO. 11
ROTOR CONDITION AFTER TEST

ER-4239
FSC 97153
Part III

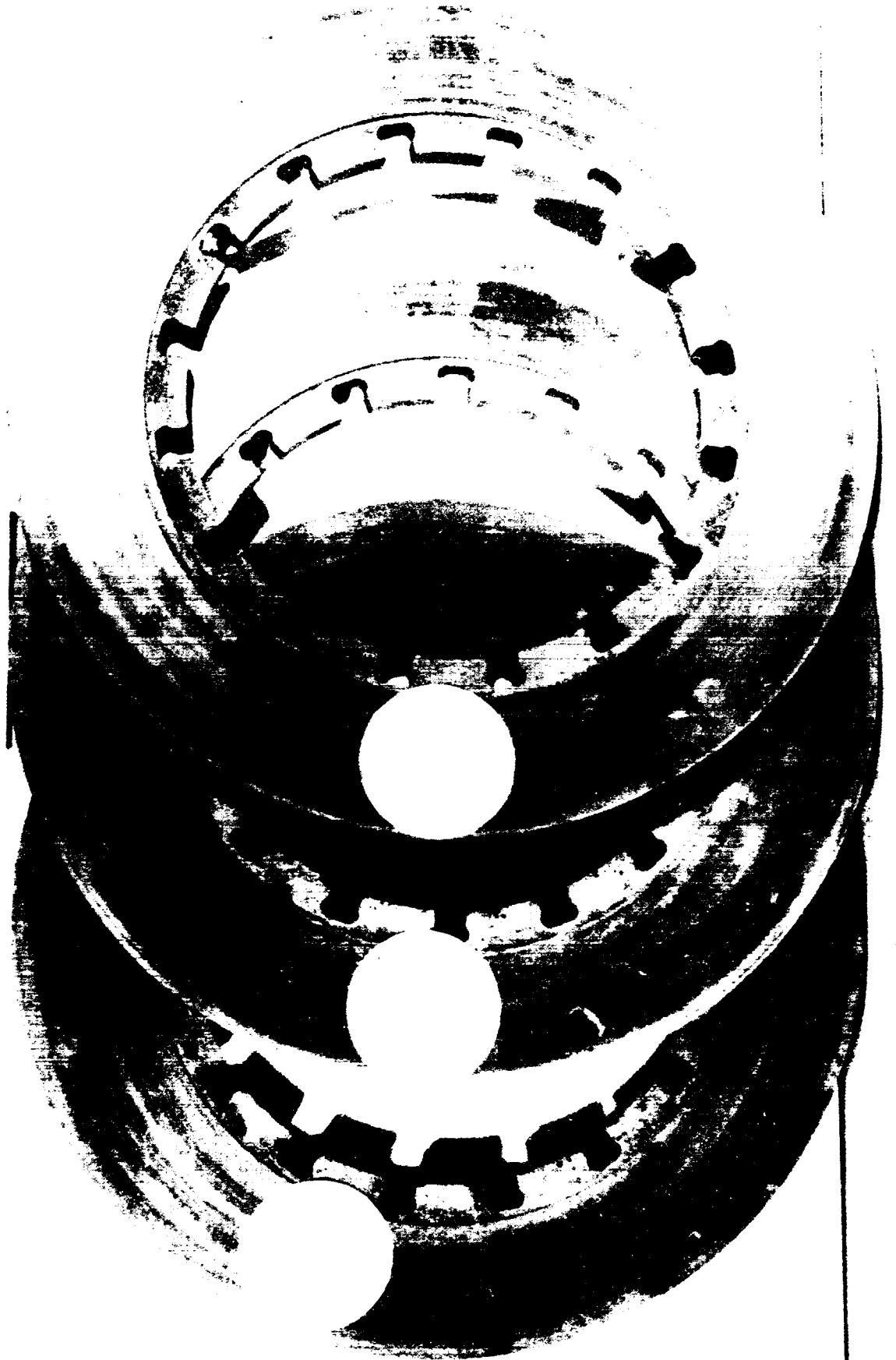

STATOR CONDITION AFTER TEST
PHOTOGRAPH NO. 12

FINAL DESIGN
STRUCTURAL CARBON BRAKE

The following conclusions were made based on Phase I and Phase II tests:

1. The thermal stresses must be reduced for the carbon brake to meet the structural requirements. This can be accomplished by processing the material to a higher temperature which produces a more graphitic structure, having a higher thermal conductivity. Graph No. 15 shows that the conductivity of the material can be increased by a factor of five, by going to a full graphite state.
2. Mass must be added to the heat sink so that its operating temperature will be compatible with the wheel and tire. The maximum operating temperature for the five-stop, 42×10^6 ft lb requirement would be approximately 1600°F . This would require the addition of 32.3 pounds to the structural carbon brake.

Graph No. 10 shows the comparison in the operation temperatures and weight between the original and final brake designs.

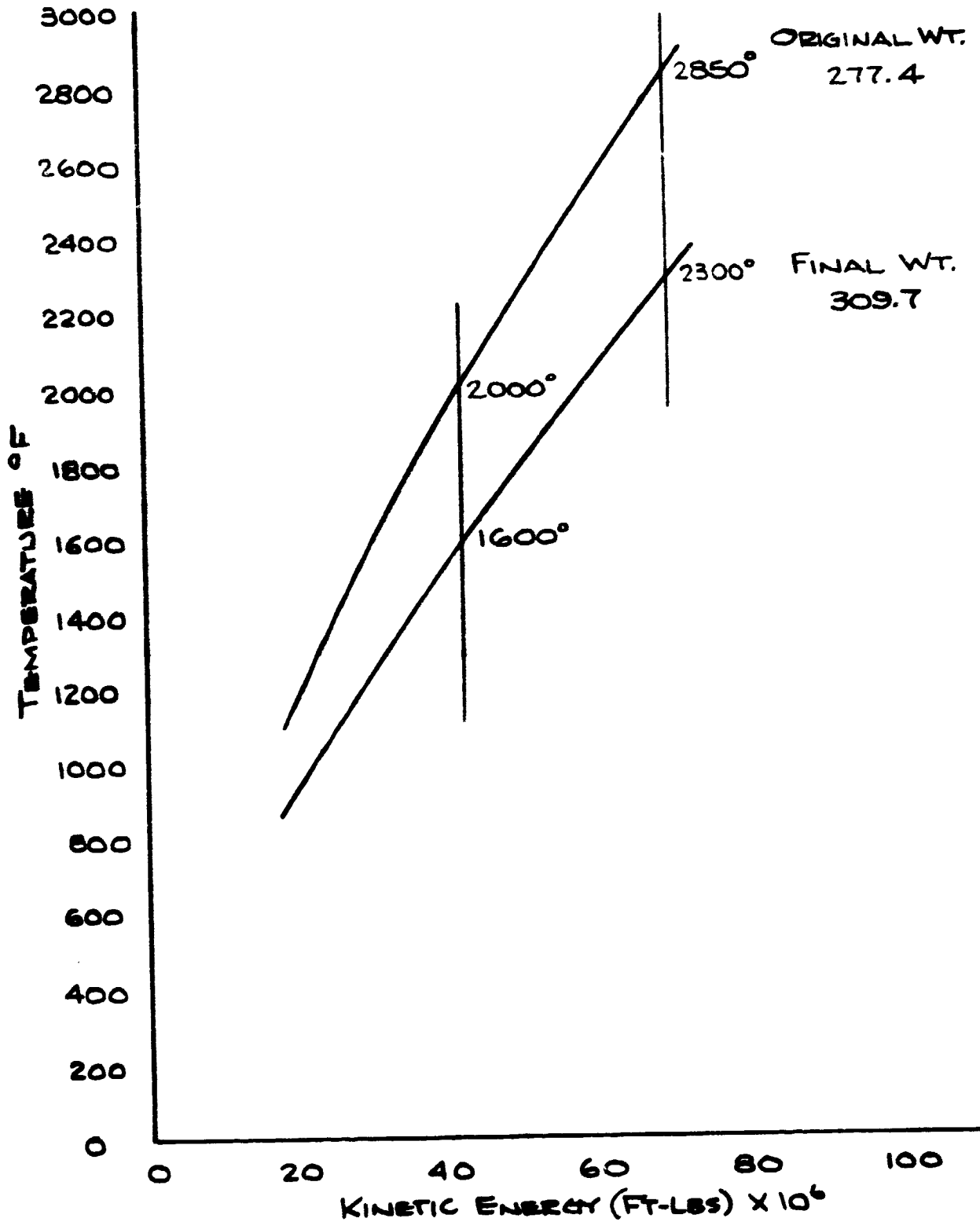

GRAPH NO. 10
 CARBON BRAKE
 HEAT SINK TEMPERATURE
 VS
 KINETIC ENERGY

FR 4239
FSC 7153
Part III

CARBON LINED BERYLLIUM PROTOTYPE TEST
SINGLE ROTOR, 16-INCH DIAMETER PARTS

The prototype test was performed on available 16-inch diameter heat sink designed to fit an 18-inch diameter beadseat wheel. The objective of the test was to verify the method of attaching the lining and to determine the frictional characteristics of the lining material.

The test was performed to simulate the space shuttle normal energy requirements shown in Table VIII, page 47. Inspection after the first stop showed that the steel washers holding the linings in place against the beryllium were melting as shown by photograph No. 13. The low thermal conductivity of the lining material caused the interface temperature to be extremely high. The washers, having very little heat sink capacity and being close to this surface, were melting.

The problem was solved by replacing the steel washer with a TZM (molybdenum, titanium, and zirconium alloy) washer that has a melting point of 4,700°F. Two more normal stops were performed with the new TZM washers verifying that the problem was solved. Photograph No. 14 shows the condition of the heat sink parts after the test.

The frictional characteristics of the heat sink were good with a coefficient of friction of approximately 0.21 as shown by pressure torque relationship on Graph No. 11.

ER-4239
FSC 97153
Part III

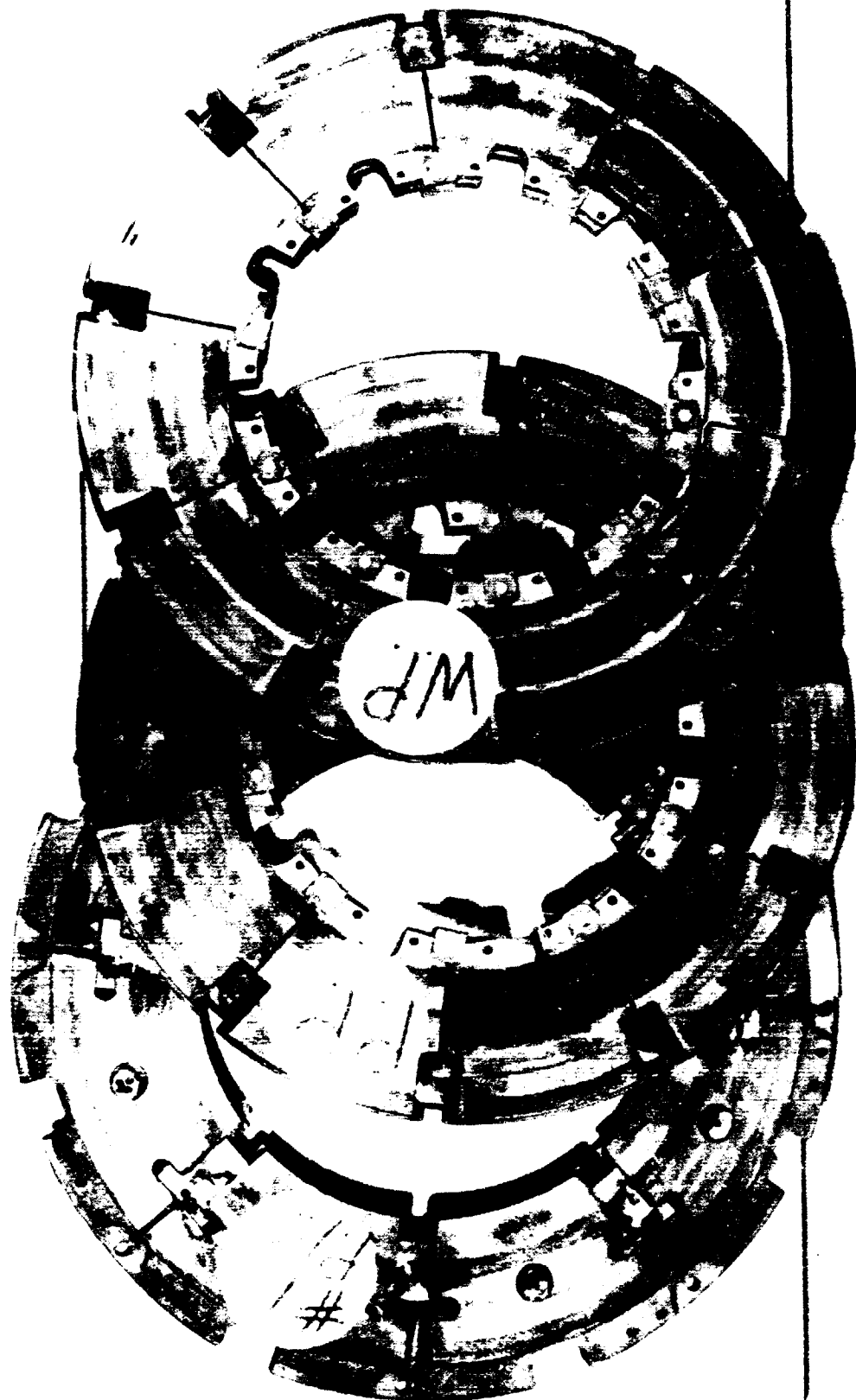

PHOTOGRAPH NO. 13
CARBON LINED BERYLLIUM HEAT SINK AFTER TEST STOP

ER-4239
FSC 97153
Part III

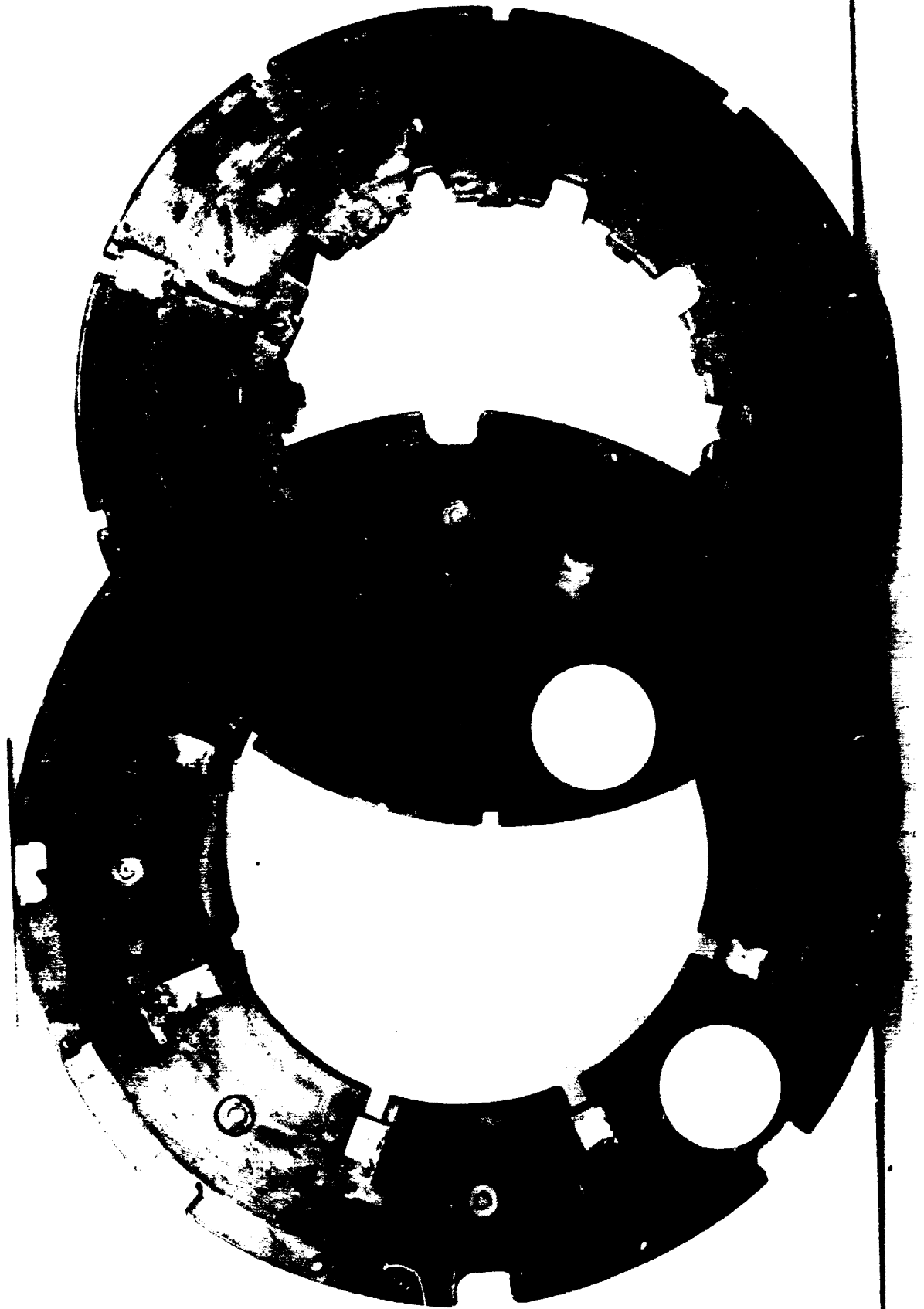

PHOTOGRAPH NO. 14
CARBON LINED BERYLLIUM HEAT SINK
AFTER THIRD NORMAL STOP SHOWING T.M.
RETAINER

ER-4239
FSC 97153
Part III

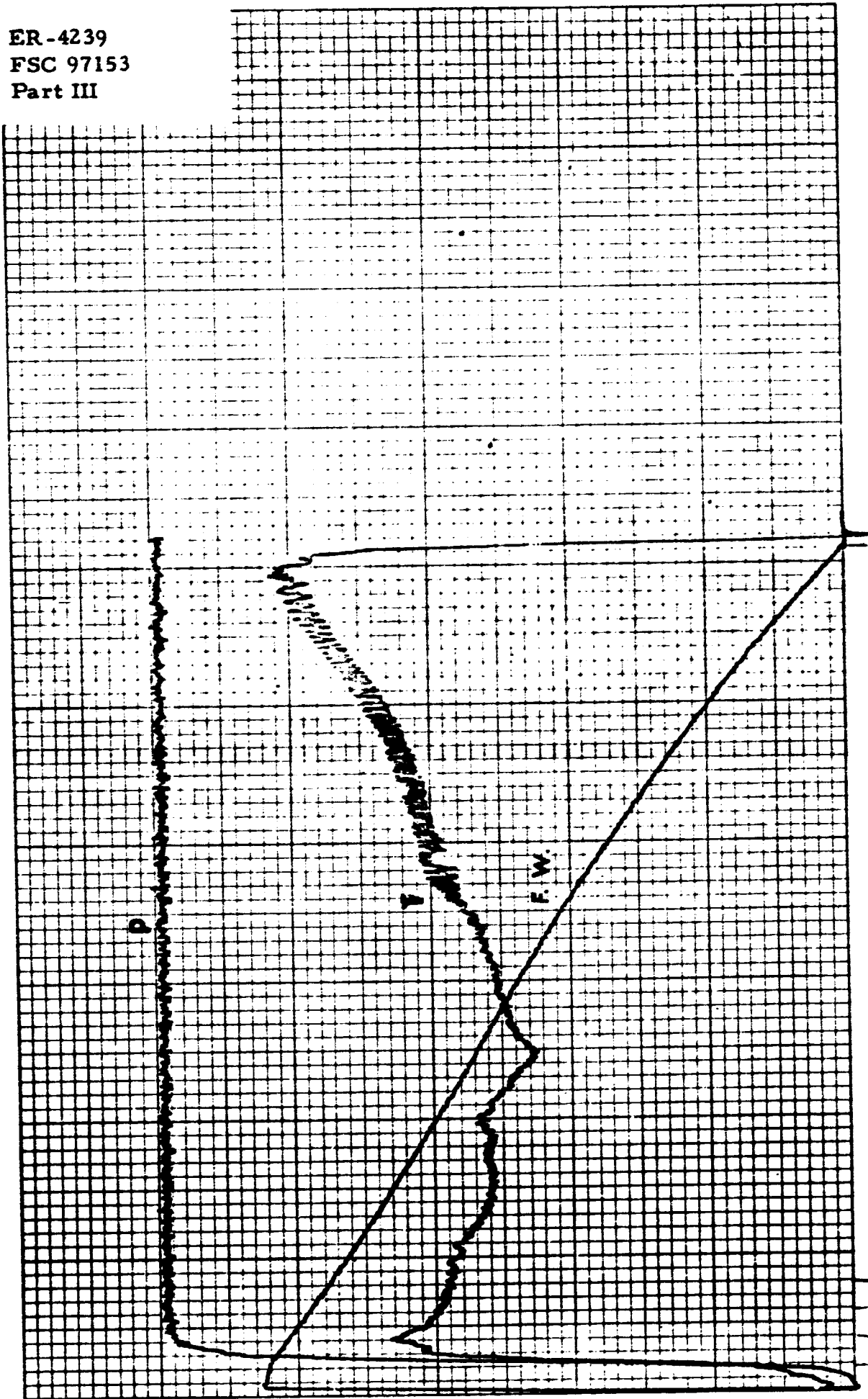

TEST NO. 4027 SPEED 2096 PRESS/IN 100 PSI T.W./IN _____ TEMP/IN _____ /IN
RUN NO. 3 STOP TIME 29.8 TORQUE/IN 500 II-ABS μ /IN _____ /IN
DATE 5-14-73 DISTANCE 546.4 R.W./IN 500 RPM F_B /IN _____ IN _____ TIME/IN 5.366

GRAPH NO. 11

ER-4239
FSC 97153
Part III

CARBON LINED BERYLLIUM
FIVE-ROTOR BRAKE TEST

A full-size carbon lined beryllium brake, P/N 2-1279-3, with the TZM washer modifications from Phase I, was tested to demonstrate the capability of the beryllium heat sink to meet the space shuttle requirements.

Two normal stops at an energy of 42×10^6 ft lbs was performed on the beryllium brake. Problems developed with the attachment of the carbon lining to the beryllium core, and the test was stopped. The frictional characteristics of the brake were good. The average coefficient of friction for the two normal stops was approximately 0.2. The torque pressure characteristics are shown on Graphs 12 and 13.

A temperature survey performed on the second normal stop indicated that the wheel tubewell and tire beadseat were reaching their critical temperatures. The data shown on Graph 14 substantiate the basic conclusion made on the structural carbon brake test in that the wheel and tire compatibility will limit the operating temperatures of the heat sink.

Photographs 15, 16, and 17 show the carbon lined beryllium heat sink before and after test.

PHASE II
 CARBON LINED BERYLLIUM

| PARAMETER | REQUIREMENTS | | AVERAGE RESULTS | |
|---|---------------|----------------|------------------|----------------|
| | NORMAL ENERGY | MAXIMUM ENERGY | NORMAL ENERGY | MAXIMUM ENERGY |
| NUMBER STOPS | 5 | 1 | 2 | |
| KINETIC ENERGY (FT-LBS) x 10 ⁶ | 42.0 | 70.0 | 42.4 | |
| INERTIA EQUIVALENT (LBS) | 27,475 | 44,556 | 27,475 | |
| LANDING VELOCITY FT/SEC | 314.0 | 318.0 | 315.1 | |
| STOP TIME (SEC) | 32.7 | 32.2 | 40.0 | |
| BRAKE TORQUE (FT-LBS) | 13,379 | 22,374 | 10,968 15,000 | |
| LINING LOADING (FT-LBS/IN ²) | 27,490 | 50,909 | 27,752 | |
| LINING POWER (FT-LBS/SEC-IN ²) | 840.7 | 1581 | 693.8 | |
| FRICTION FORCE (PSI) | 16.2 | 27.1 | 13.2 18.2 | |
| HEAT SINK TEMPERATURE | 1300°F | 1800°F | 1300°F + | |

TABLE VIII

ER-4239
FSC 97153
Part III

B.F. GOODRICH AEROSPACE & DEFENSE PRODUCTS
Wheel and Brake Plant Troy, Ohio

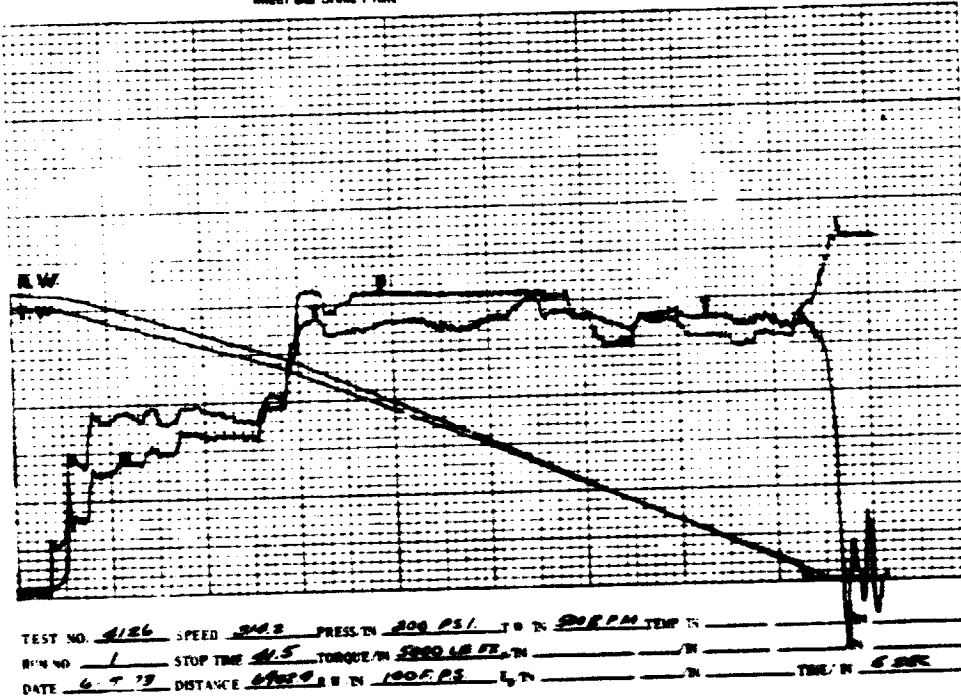

GRAPH NO. 12
Carbon Lined Beryllium Normal Energy Stop
Torque, Pressure VS Stop Time

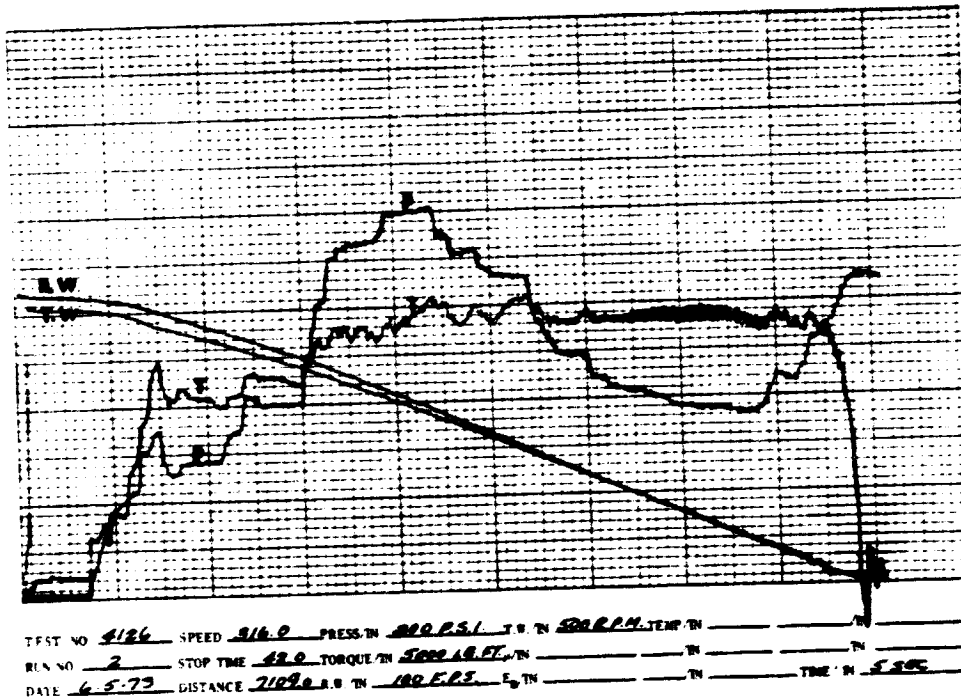

GRAPH NO. 13
Carbon Lined Beryllium Normal Energy Stop
Torque, Pressure VS Stop Time

ER-4239
FSC 97153
Part III

TEMPERATURE SURVEY
CARBON LINED BERYLLIUM BRAKE
KE = 42×10^6 FT-16s

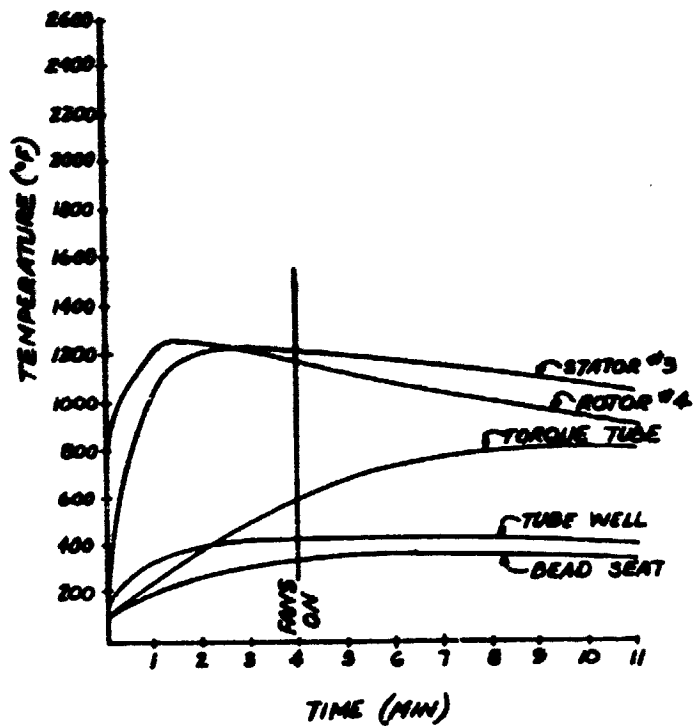

GRAPH NO. 14

ER-4239
FSC 97153
Part III

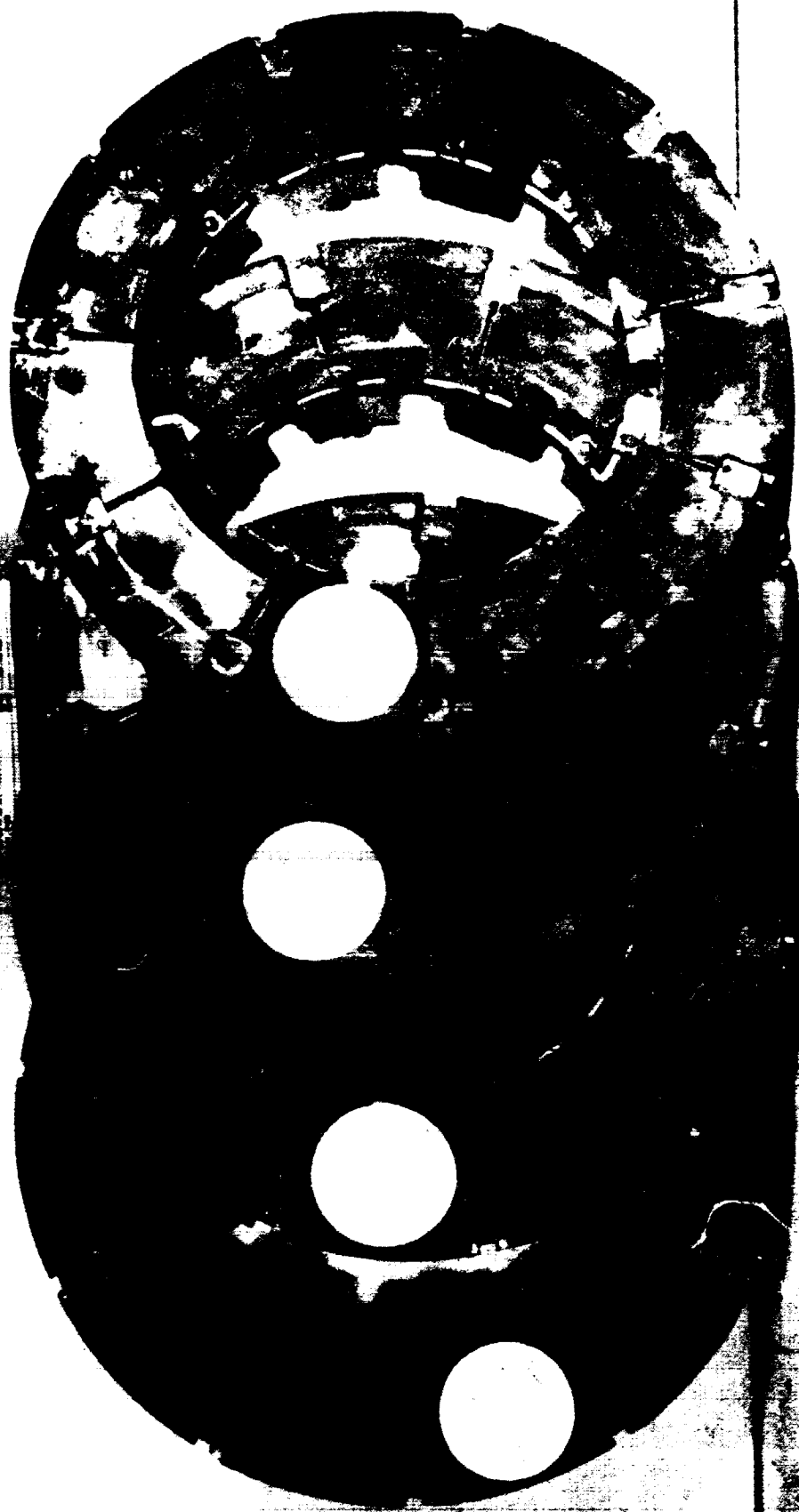

STATOR COMPONENT AFTER TEST

PHOTOGRAPH NO. 15

ER-4239
FSC 97153
Part III

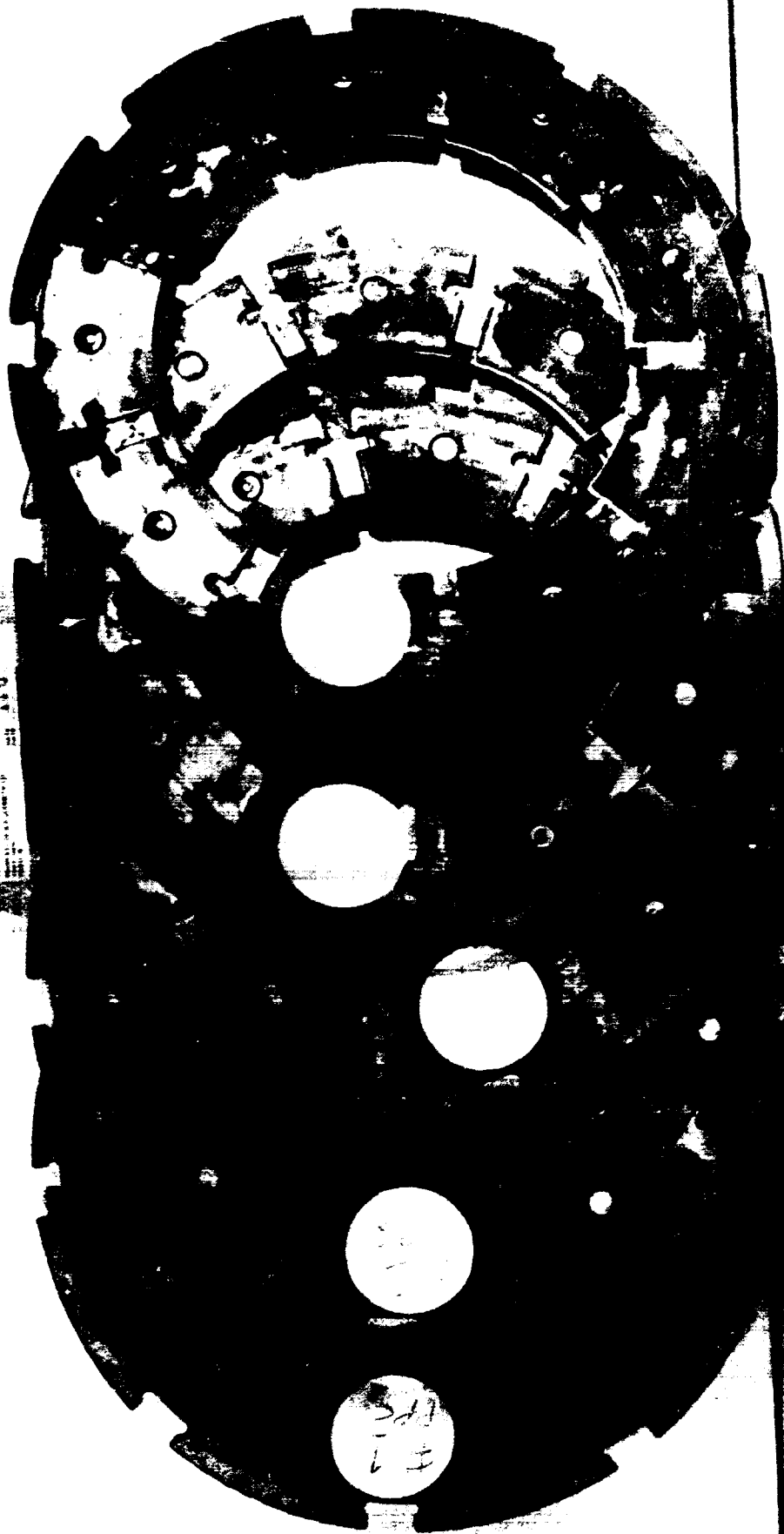

ROTOR CONDITION AFTER TEST
PHOTOGRAPH NO. 16

ER-4239
FSC 97153
Part III

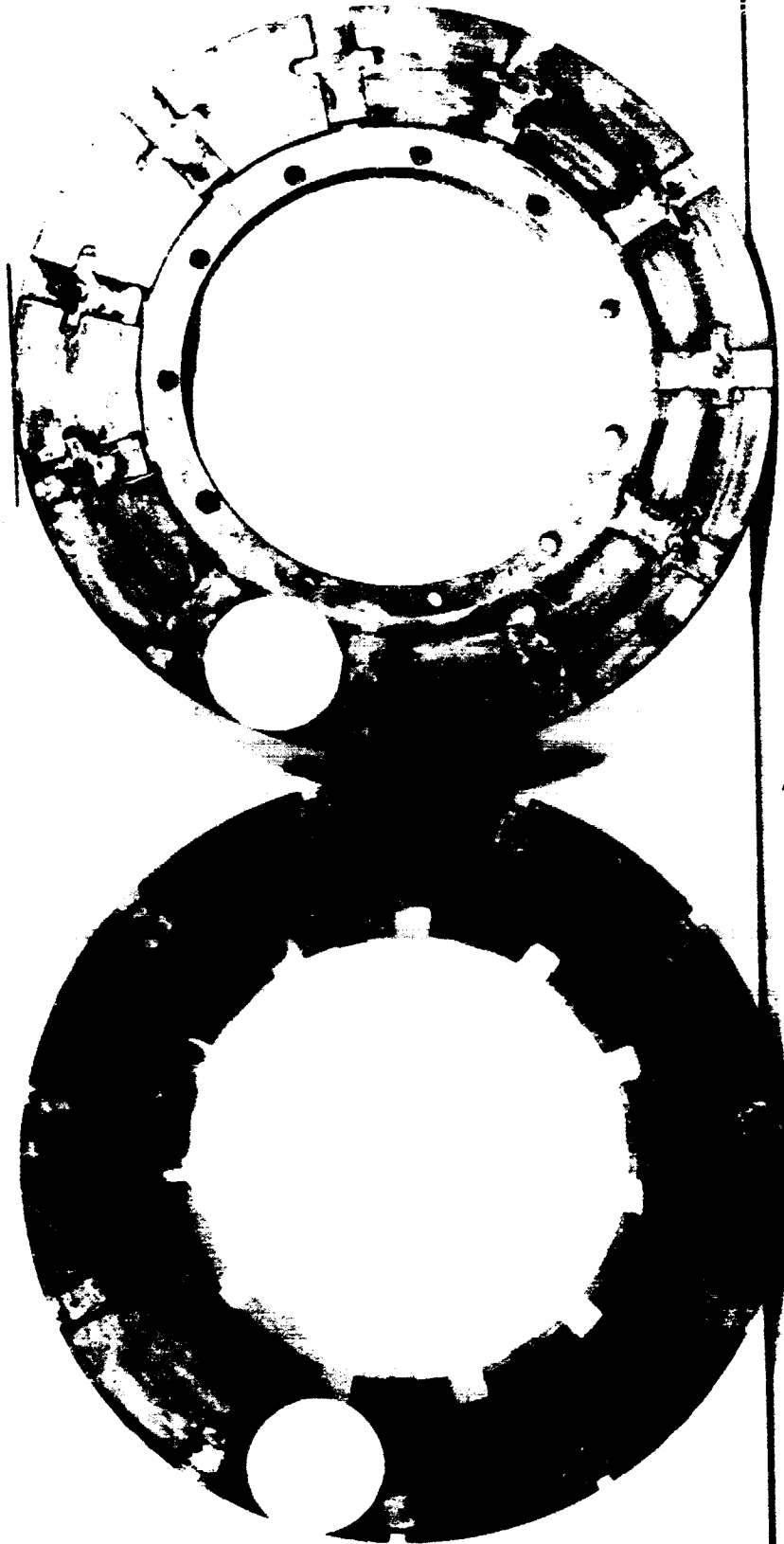

PHOTOGRAPH NO. 17
PRESSURE PLATE & BACK PLATE CONDITION
AFTER TEST

ER-4239
FSC 97153
Part III

PROBLEM AREA

The problems that occurred with the carbon lined beryllium brake were melting of the steel lining attachment and warpage of the lining segments. Colored movies (*) of one stop showed that the lining material was getting extremely hot during the stop (approximately 3000^oF +) while the beryllium core was still relatively cold. The high lining temperature warped the linings and caused the steel transferring the torque from the lining into the beryllium to melt. The corresponding decrease in lining bearing area, caused the linings to fail. The reason for the high lining temperature was the low thermal conductivity in the perpendicular direction of the carbon lining (See Graph No. 15). The heat was being stored in the lining instead of being transferred into the relatively cold beryllium core. The final bulk temperature of the heat sink was in the 1200^o to 1300^oF range as predicted.

(*) Movie No. A-137, showing the normal energy stop supplied to NASA Manned Spacecraft Center, Mechanical Systems Branch, Houston, Texas; Attention: J. E. Martin. Marked for Contract NAS-9-12049.

SOLUTIONS

1. Increase the thermal conductivity of the lining.

The temperature of the friction interface is on the border line of melting the steel attachment. Graph 15 shows that heat treating the carbon lining segment improves its thermal conductivity by a factor of five. This increase in the thermal conductivity should lower the temperature of the friction interface by transferring the heat from the lining segment into the beryllium core.

2. Improve the high temperature stability of the lining.

Heat treating the lining segment also improves its high temperature stability. The lining warpage was due to the operating temperature exceeding the processing temperature of the material. The high interface temperature continued to graphitize and shrink that surface of the lining segment. Processing the material to higher temperature will uniformly graphitize the material and minimize the warpage problem.

3. Improve the method of attaching the lining by increasing the bearing area and holding down the edges of the lining segments.

The method of attaching the lining segment can be revised to minimize the problems caused by lining warpage. Photograph 17 and Figure 9 show the method of attachment of the lining segments for the stator and back plate. The backplate attachment holds the edges of the lining segment down while the stator attachment allows the segment to curl. The backplate attachment was a proven but heavier design and was used only for attachment of lining to the backplate. The advantages of the backplate attachment design now justified the increase in weight and should be used for attaching the lining to the rotors and stators as shown by Fig. 10.

ER-4239
FSC 97153
Part III

PRESENT DESIGN

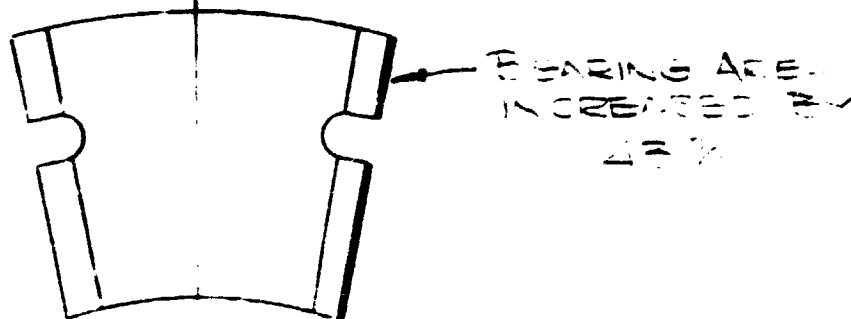
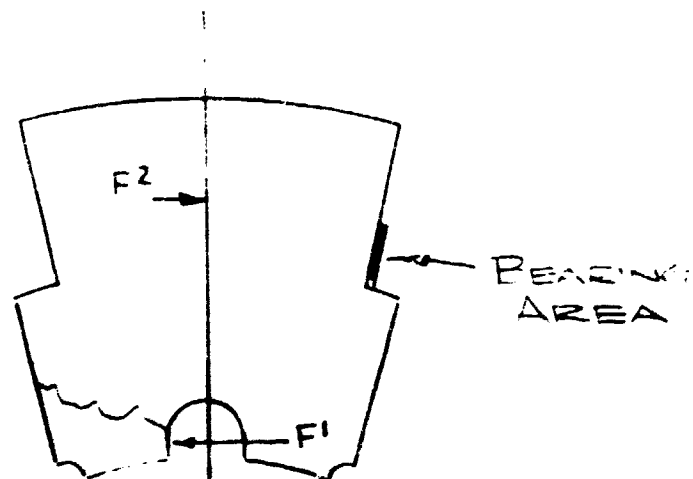

BACKPLATE DESIGN

STRESS ANALYSIS IN STATOR
LINE - SEGMENT

Figure 9

ER-4239
FSC 97153
Part III

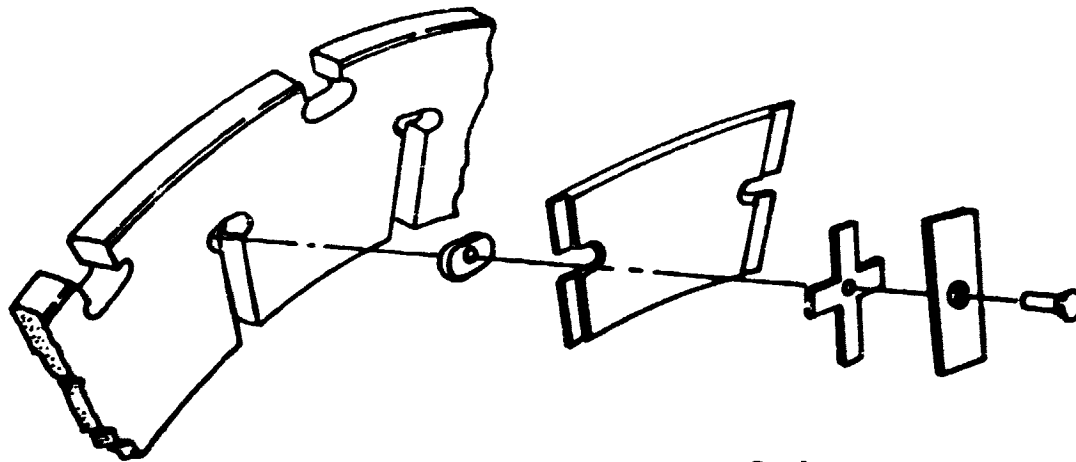

ROTOR DESIGN

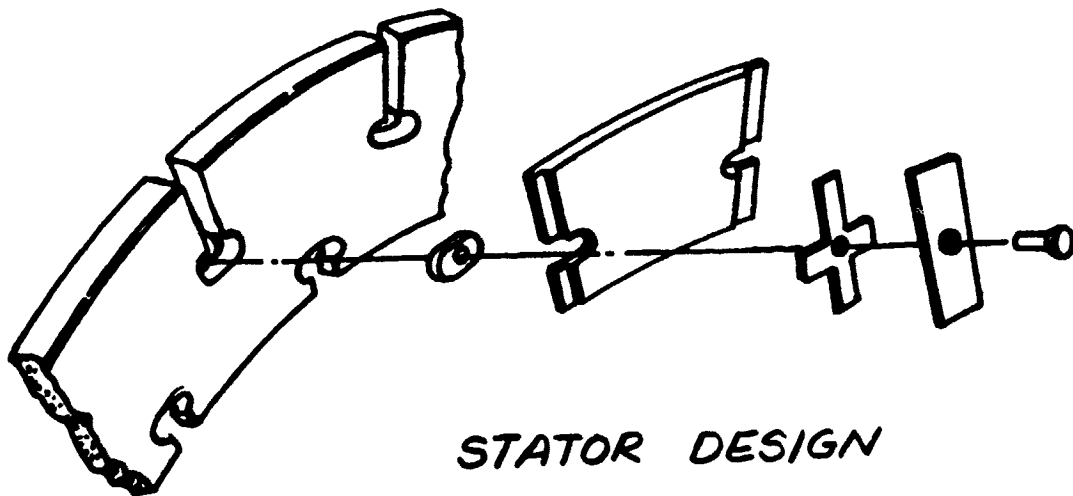

STATOR DESIGN

Figure 10
Proposed Rotor and Stator Lining Attachment

FINAL DESIGN
CARBON LINED BERYLLIUM BRAKE

The following conclusions were made based on Phase I and Phase II tests:

1. The thermal conductivity and high temperature stability of the lining segment must be increased to eliminate the melting of the steel lining attachment and warpage of the lining segment.
2. The method of attaching the lining to the rotor and stators should be changed to the method used on the back plate. The back plate design increases the bearing area and retains the edges of the lining segment, minimizing the problems caused by lining warpage.

There was no change in the operating temperature between the original and final brake design. The brake weight will increase by 7.2, found due to the change in lining attachment for rotors and stators as shown on Table IX.

WEIGHT TRADEOFF

| | 5-Rotor Carbon Lined Beryllium | |
|-----------------------|--------------------------------|-------|
| | OLD | NEW |
| ROTORS | 43.4 | 44.8 |
| STATORS | 34.7 | 37.3 |
| WEAR PLATE | 4.5 | 5.7 |
| BACK PLATE | 9.1 | 9.1 |
| TORQUE TUBE | 13.6 | 13.6 |
| PISTON HOUSING ASSY. | 20.3 | 20.3 |
| INSULATION | --- | --- |
| TOTAL BRK. ASSY. WT. | 125.6 | 130.8 |
| WHEEL ASSEMBLY WEIGHT | 149.3 | 151.3 |
| TOTAL WHL. & BRK. WT. | 274.9 | 282.1 |

TABLE IX

ER-4239
FSC 97153
Part III

REFERENCES

1. NAS Contract No. 9-12049, Exhibit "A", Amendment 4S.
2. Carbon Brake Failure Analysis, Appendix A, pages A-1 thru A-6
Number 4 Stator, P/N 133-387-1
3. Stress Analysis - Structural Beryllium Heat Sink
P/N 2-1279-3, B-1 thru B-4

PRECEDING PAGE BLANK NOT **FILED**

ER-4239
FSC 97153
Part III

APPENDIX A

**Carbon Brake Failure Analysis
Number 4 Stator, P/N 133-387-1**

ER-4239
FSC 97153
Part III, App. A

CARBON BRAKE FAILURE ANALYSIS

Number 4 Stator, P/N 133-387-1

INTRODUCTION

The No. 4 stator failed during initial Phase II testing of the full size carbon brake to the space shuttle 5-stop requirement.

Visual inspection indicated that the outside diameter of the disk was contacting harder than the inside diameter and, therefore, getting hotter. The thermal stresses developed due to a hot band on the outside diameter of the disk puts the inside diameter in tension.

This thermal stress, along with the mechanical loads, is believed to have caused failure.

ER-4239
FSC 97153
Part III, App. A

THEORETICAL ANALYSIS

The theoretical thermal and mechanical stresses were calculated assuming a 1200^oF temperature gradient across the face of the disk and using the mechanical loads recorded at time of failure.

ER-4239
FSC 97153
Part III, App. A

CONCLUSION

The analysis shows that the 1200^oF temperature gradient is the major stress and is sufficient to cause failure.

Theoretical Mechanical Stress Analysis of 133-387-1 Stator

Required Data

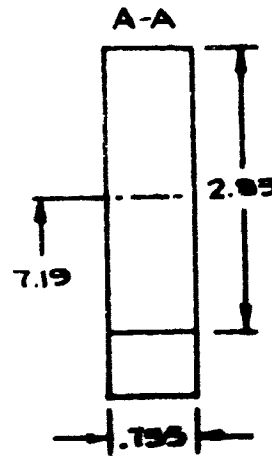
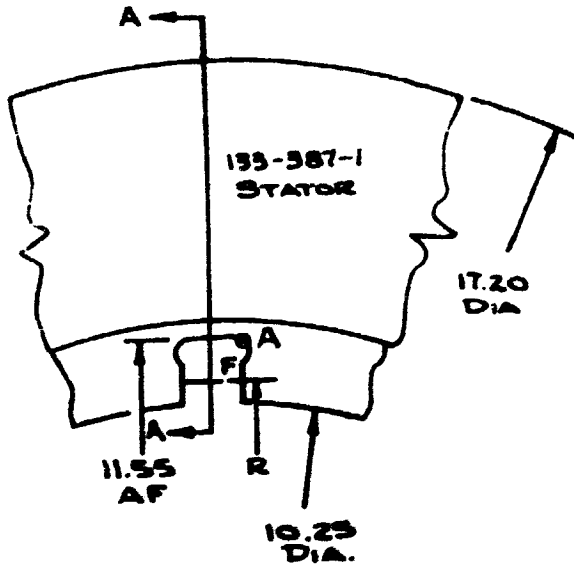

- T = Torque = 10,000 ft lb.
- N = Number of Stators = 5
- n = Number of Drives/Stator = 16
- R = 5.33
- F = Force on Lug = $12T/NnR = 281.4$ lbs

Assumed Loading Conditions

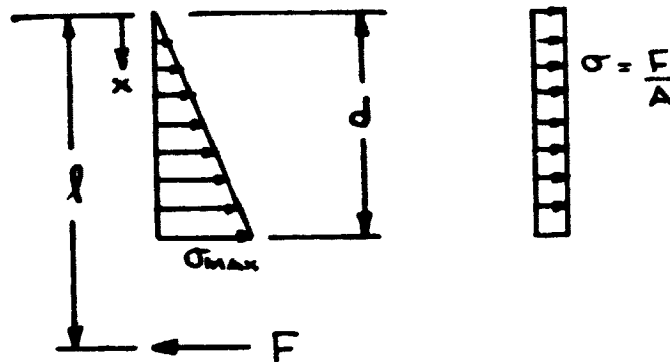

Analysis at A

$$\sigma_x = \sigma_{MAX} x/d$$

$$\Sigma \sigma_x t \delta x = F l$$

$$\Sigma \sigma_{MAX} x/d t \delta x = F l$$

$$\int_0^d \frac{\sigma_{MAX}}{d} t x^2 dx = F l$$

$$\sigma_{MAX} = 3Fl/td^2$$

Where: $l = 17.20/2 - R = 3.27$ in.
 $d = (17.20 + 11.55)/2 = 2.83$ in.
 $t = .755$ in.

SCF = STRESS CONCENTRATION FACTOR = 1.57

$$f_A = \sigma_{MAX} + \sigma_{TEN} = 386 \text{ psi}$$

NOTE: The above analysis was checked experimentally with an F-14 carbon stator. The two analysis compared very well.

Theoretical Thermal Stress Analysis of 133-387-1 Stator

Thermal stress analysis was performed by assuming the disk to be cut into two concentric rings. The temperature of the outer ring was 1200°F while the inner ring remained at room temperature. The force required to hold the two rings together was calculated and then used to determine the stresses imposed on the inner ring. The analysis follows.

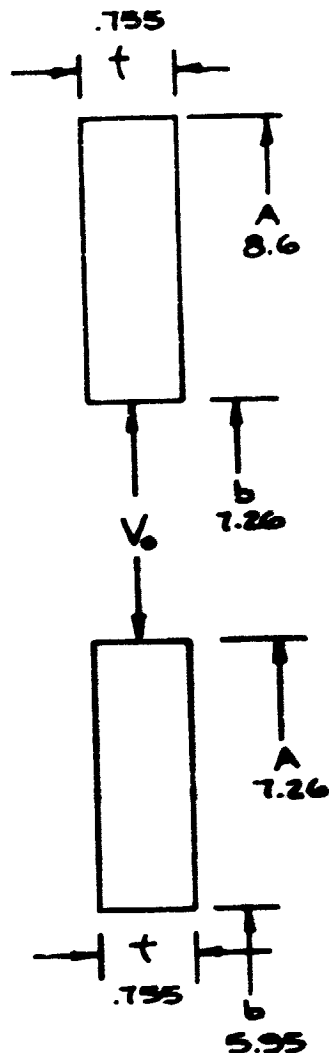

OUTER RING EXPANSION:

$$\delta_b = bV_o \left[\frac{A^2 + b^2}{A^2 - b^2} + .3 \right] / Et$$

$$= 33.51 \times 10^{-6} V_o$$

INNER RING EXPANSION:

$$\delta_A = AV_o \left[\frac{A^2 + b^2}{A^2 - b^2} - .3 \right] / Et$$

$$= -26.33 \times 10^{-6} V_o$$

$$\delta_A + \delta_B = .01452$$

$$V_o = 2023\#/in.$$

(Thermal expansion of outer ring inner diameter using expansion coefficient of .002 in./in.)

$$\text{Thus: } f_t = A^2 V_o (b^2 + r^2) / tr^2 (A^2 - b^2)$$

$$= 16322 \text{ psi}$$

ER-4239
FSC 97153
Part III

APPENDIX B

Stress Analysis -- Structural Beryllium
Heat Sink
Brake P/N 2-1279-3

STRESS ANALYSIS - STRESS ANALYSIS OF BERYLLIUM HEAT SINK
Brake P/N 2-1279-1

The stress analysis of the five-rotor carbon lined beryllium heat sink is quite complex. The following is a stress analysis showing that the unit loading of the beryllium heat sink in the proposed Space Shuttle application is significantly below the proven capability of the C-5A Beryllium heat sink.

LOADING CONDITIONS

The rotors and stators for the space shuttle are the same size and basic design as the C-5A brake except for thickness. The following shows the comparison in thickness and loading conditions.

| | C-5A Beryllium Brake | Proposed* NASA Brake |
|---|----------------------------|----------------------------|
| Rotor Thickness (inches) | .37 | .540 |
| Stator Thickness (inches) | .42 | .575 |
| Average Torque Required for Maximum Energy Stop | 202,512 in lb | 268,488 in lbs |

*Five-Rotor Carbon Lined Beryllium Heat sink

ANALYSIS OF BERYLLIUM STATORS

C-5A

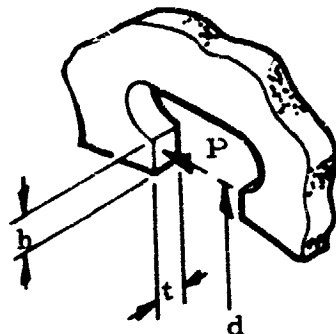

Dimensions:

- t = .42 in
- h = .38 in
- d = 10.5 in
- N_s = no. of slots = 11
- N = no. of stators = 4

Loads:

- IE = 32741 lbs
- T = 202512 in lbs

$$P = 2T / (*K_e * K_l N_s N d)$$

$$= 1370 \text{ lbs}$$

$$\text{Stress} = P / t h = \underline{8590 \text{ psi}}$$

NASA

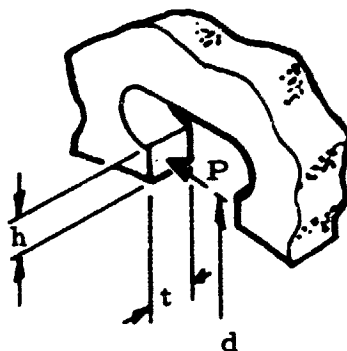

Dimensions:

- t = .575 in
- h = .38 in
- d = 10.5 in
- N_s = 11
- N = 5

Loads:

- IE = 69870 lbs
- T = 268,488 in lbs

$$P = 1453 \text{ lbs}$$

$$\text{Stress} = \underline{6649 \text{ psi}}$$

*Mechanical efficiency factors for heat stack and drive lugs.

ANALYSIS OF BERYLLIUM ROTORS

C-5A

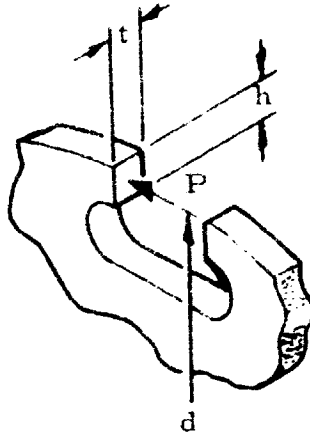

Dimensions:

- t = .37 in
- h = .35 in
- d = 18.0 in
- N_r = no. of slots = 9
- N = no. of rotors = 4

Loads:

- IE = 32741 lbs
- T = 202512 in lbs

$$P = 2T / (*K_e * K_l N_r N d)$$

$$= 977 \text{ lbs}$$

$$\text{Stress} = P / t h = \underline{7540 \text{ psi}}$$

NASA

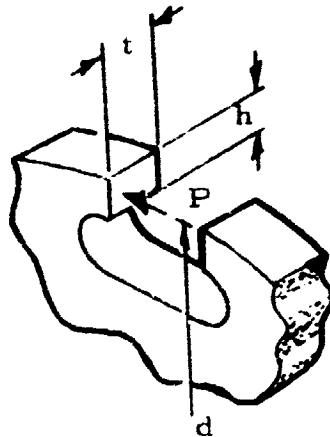

Dimensions:

- t = .54 in
- h = .35 in
- d = 18.0 in
- N_e = 9
- N = 5

Loads:

- IE = 69870 lbs
- T = 268,488 in lb

$$P = 1036 \text{ lbs}$$

$$\text{Stress} = 5481 \text{ psi}$$

*Mechanical efficiency factors for heat stack and drive lugs.

CONCLUSIONS

The initial stresses of the proposed structural beryllium rotors and stators for the Space Shuttle application are approximately 22.6 and 27.3 percent respectively lower than the proven capability of the C-5A beryllium heat sink.

END

DATE

FILMED

JAN 25 1974