

NASA CR 112312

BC-8838-FR

FINAL REPORT

INVESTIGATION OF LOW-COST FABRICATION  
OF ABLATIVE HEAT SHIELDS

by

V. P. Massions and R. W. Mach  
BRUNSWICK CORPORATION  
Technical Products Division  
4300 Industrial Ave.



prepared for

NATIONAL AERONAUTICS AND SPACE ADMINISTRATION

December 28, 1973

Contract NAS 1-10864

NASA Langley Research Center  
Langley Station, Hampton, Va.

(NASA-CR-112312) INVESTIGATION OF  
LOW-COST FABRICATION OF ABLATIVE HEAT  
SHIELDS Final Report (Brunswick Corp.)  
93 p HC \$6.75

85

CSCL 13A

N74-13665

Unclas

G3/33

24208

NASA CR 112312

BC-8838-FR

**FINAL REPORT**

**INVESTIGATION OF LOW-COST FABRICATION  
OF ABLATIVE HEAT SHIELDS**

by

V. P. Massions and R. W. Mach  
**BRUNSWICK CORPORATION**  
Technical Products Division  
4300 Industrial Ave.

prepared for

**NATIONAL AERONAUTICS AND SPACE ADMINISTRATION**

**December 28, 1973**

**Contract NAS 1-10864**

**NASA Langley Research Center  
Langley Station, Hampton, Va.**

## TABLE OF CONTENTS

	PAGE
SUMMARY . . . . .	1
INTRODUCTION . . . . .	1
FABRICATION, TEST AND EVALUATION . . . . .	3
Task 1. Resin Evaluation and Panel Curing . . . . .	3
Mixing evaluation . . . . .	3
In-process cure tests . . . . .	7
Minimum cure time . . . . .	9
Dielectric cure . . . . .	9
Task 2. Resin Dispersement and Face Sheet Evaluation . . . . .	17
Evaluation of ablative mixes . . . . .	19
Evaluation of insulative mixtures . . . . .	24
Integral skin . . . . .	25
Bonding localized face skins . . . . .	25
Test results . . . . .	26
Task 3. Feasibility Study of Low Weight, Inexpensive Reinforcement Matrix . . . . .	29
Fabrication . . . . .	29
Discussion . . . . .	30
Task 4. Large Panel Fabrication . . . . .	37
Mold design . . . . .	37
Fabrication procedure . . . . .	38
Results of fabrication . . . . .	40
Problems encountered . . . . .	40
Problem discussion and analysis . . . . .	41
Estimated costs for molds and equipment . . . . .	44
Labor and flow time . . . . .	44
CONCLUSIONS . . . . .	55
RECOMMENDATIONS . . . . .	57
APPENDIX A	
Work Summaries of Dielectric Curing . . . . .	59
APPENDIX B	
Work Summaries of Dielectric Curing . . . . .	77

LIST OF TABLES

TABLE	PAGE
1. Material Suppliers . . . . .	3
2. Material Combinations, High Density Ablative Mixtures . . . . .	21
3. Tensile Test Results (Localized Skin Faces) . . . . .	28
4. Estimated Hours for Fabrication of a Low Density Elastomeric Flat Panel . . . . .	47
5. Estimated Hours for Fabrication of a Low Density Elastomeric Flat Panel (Steam-heated) . . . . .	48
6. Estimated Hours for Fabrication of a Low Density Elastomeric Flat Panel (Dielectric Cure) . . . . .	49
7. Estimated Hours for Fabrication of a Low Density Elastomeric Flat Panel Molding Only (Steam-heated) . . . . .	50
8. Estimated Hours for Fabrication of a Low Density Elastomeric Flat Panel Molding Only (Dielectric Cure) . . . . .	51
9. Estimated Hours for Fabrication of a Low Density Elastomeric Flat Panel (Dielectric Cure) . . . . .	52

## LIST OF ILLUSTRATIONS

FIGURE	PAGE
1. Tumbling Can . . . . .	5
2. Compression Mold - Dielectric Cure . . . . .	12
3. Single-Density Panel - Dielectrically Cured . . . . .	14
4. Dual-Density Panel - Dielectrically Cured . . . . .	15
5. Ablative Test Panel in Mold (End Plate Removed) . . . . .	20
6. Flame Test of Ablative Panel . . . . .	22
7. Ablative Test Panel After Flame Test . . . . .	23
8. Tensile Test Specimen . . . . .	27
9. Roving Assembly Fixture . . . . .	31
10. Combination Reinforcement Honeycomb Core/Roving Strand . . . . .	32
11. Combination Reinforcement Resin/Microballoons/Urethane Core . . . . .	34
12. Roving Strand Needling Machine (Developmental). . . . .	35
13. Roving Strand Needling Machine (Developmental). . . . .	36
14. Compression Mold - Dielectric Cure . . . . .	45

# INVESTIGATION OF LOW-COST FABRICATION OF ABLATIVE HEAT SHIELDS

by Vincent P. Massions and Robert W. Mach  
Brunswick Corporation

## SUMMARY

This effort was a follow-on to a previous NASA contract NAS 1-9945. The objectives were to further reduce panel fabrication costs and evaluate methods of improving the thermal and mechanical performance of ablative panels.

This report covers the investigation of materials in regard to their handling properties and cure cycles, and describes a method for determining the in-process cure level of ablative materials.

Dielectric curing of ablative panels was evaluated and potential man-hour reductions are shown over panels cured by the steam-heated presses. Dual-density panels are found to have good ablative characteristics and handling properties, and provide an overall reduction in panel density.

Coatings to reduce moisture penetration were found to be partially effective, but created unsatisfactory surface conditions such as charring, cracking, or blistering. Adhesives which could be used for bonding localized face sheets at panel attach points were acceptable. Tensile strength values for skin-to-panel bond, for both film and liquid adhesives, are well above minimum requirements. An inexpensive reinforcement matrix to replace fiberglass honeycomb core material was investigated and found to be unsatisfactory. Erosion of the ablative surface was greater when compared with the honeycomb core reinforcement matrix.

## INTRODUCTION

The Brunswick Corporation had previously evaluated steam-heated press molding as an economical means of fabricating ablative panels. This method proved to be cost-competitive with other fabrication approaches, such as the vacuum bag technique.

The purpose of this evaluation was to further reduce fabrication costs by:

- (i) Minimizing handling and cure cycles.
- (ii) Developing an in-process technique to prove the cure level of ablative materials.

- (iii) Evaluate dielectric curing of ablative panels.
- (iv) Establish techniques for fabricating dual-density panels.
- (v) Investigate resins for molding integral skins on panel ablative surfaces.
- (vi) Test adhesives suitable for bonding localized skins at panel attach points.
- (vii) Study the feasibility of an inexpensive reinforcement matrix which could replace the honeycomb core.
- (viii) Fabricate a 2 ft. X 4 ft. panel using dielectric cure to prove feasibility and project production costs for full-size panels.

Techniques developed during this program have established ways to reduce initial tooling costs and man-hours over other methods used to fabricate ablative panels. Panels fabricated in accordance with the recommended procedures have greatly improved handleability characteristics. In addition, material compositions are presented which reduce overall panel densities.

Measurements within the body of this report are presented in the international system of units (SI), followed by United States customary units in parentheses. Except for weight measurements, all work was performed using U.S. customary units.

# FABRICATION, TEST AND EVALUATION

## Task I

### Resin Evaluation and Panel Curing

The principal objective of this task was to evaluate silicone elastomeric resins made by at least three suppliers to establish the most cost effective resin system for use in fabricating a low-density elastomeric ablator consisting of 20 percent (by mass) resin and 80 percent (by mass) phenolic Microballoons. Specific objectives were directed toward:

- (i) The reduction of cure times and minimization of handling costs.
- (ii) Using not more than two of the best resin system formulations, establish the minimum acceptable cure cycle and devise an in-process test to prove the cure level of the material.
- (iii) Fabricate a mold and evaluate dielectric curing of the best established resin system formulation and in addition, evaluate additives intended to shorten the dielectric cure cycles.

Mixing evaluation. - Elastomeric silicone resin materials were purchased from three suppliers as shown in Table 1.

Table 1  
MATERIAL SUPPLIERS

Supplier	Material Identification
Isochem Cook Street Lincoln, Rhode Island	Isochem No. 1167
General Electric Silicone Products Dept. Waterford, New York	R.T.V. 511 R.T.V. 615 R.T.V. 655
Dow Corning Corp. Midland, Michigan	Sylgard 182 Sylgard 186 Ablative No. 325 Aerospace Sealant No. 93-027



Each resin batch consisted of the resin and hardener which was mixed separately in accordance with suppliers' instructions and then added to the Microballoons. The materials were placed into a tumbling device and rotated until a satisfactory mix was obtained. The tumbling container was a 3.785 dm<sup>3</sup> (one-gallon) paint can with a snap-on lid made with an attachment for placing the can in a lathe chuck for rotation (Figure 1). The can also contained three 1.27 cm X 7.62 cm (1/2 in. X 3 in.) bolts with two nuts on each bolt. One nut was located midway along the length of each bolt and the other located at the end of each bolt. The bolt and nut assemblies were placed in the tumbling can along with the batch mixture to aid in the mixing process. The tumbling can was rotated approximately 38 rpm.

To facilitate the mixing (or wetting) of Microballoons, the mixture was extruded through a screen and into the tumbling can as follows:

Approximately 10 grams of Microballoons were thoroughly hand-mixed into the resin/hardener system. One-fourth of this mixture was then extruded into the tumbling can through a 3.17 mm (1/8 in.) mesh screen wire, followed by approximately one-fourth of the dry Microballoons. The combination was then hand-mixed to distribute the wetted particles throughout the dry Microballoons. This sequence was repeated until the entire batch was extruded through the screen.

Each of the different resin systems was mixed and tumbled as described above. Visual inspections of the mixture were made at 15 minute intervals starting 30 minutes after tumbling commenced. A satisfactory mix was obtained when an even distribution of both resin and Microballoons was noted, and when the material exhibited good adhesion to itself after being squeezed in the hand.

The following observations were made of the tumbling evaluation for each resin/Microballoon system:

Isochem No. 1167:

Batches of this material were tumbled for a total of 11 hours, but the resin and Microballoons did not completely mix. The resin formed lumps which varied in size from 0.51 mm (0.020 in.) to 7.62 mm (0.300 in.). Other tests followed with similar results and very little wetting of Microballoons. This material was eliminated because of its inadequate mixing characteristics, and the supplier was notified accordingly.

General Electric R.T.V. 511:

This material does not have good wettability. No improvement in mixing was observed beyond 120 minutes with intermittent scraping of the material from the wall of the tumbling can. The material adhered to itself, but did not compact as well as some of the other materials.

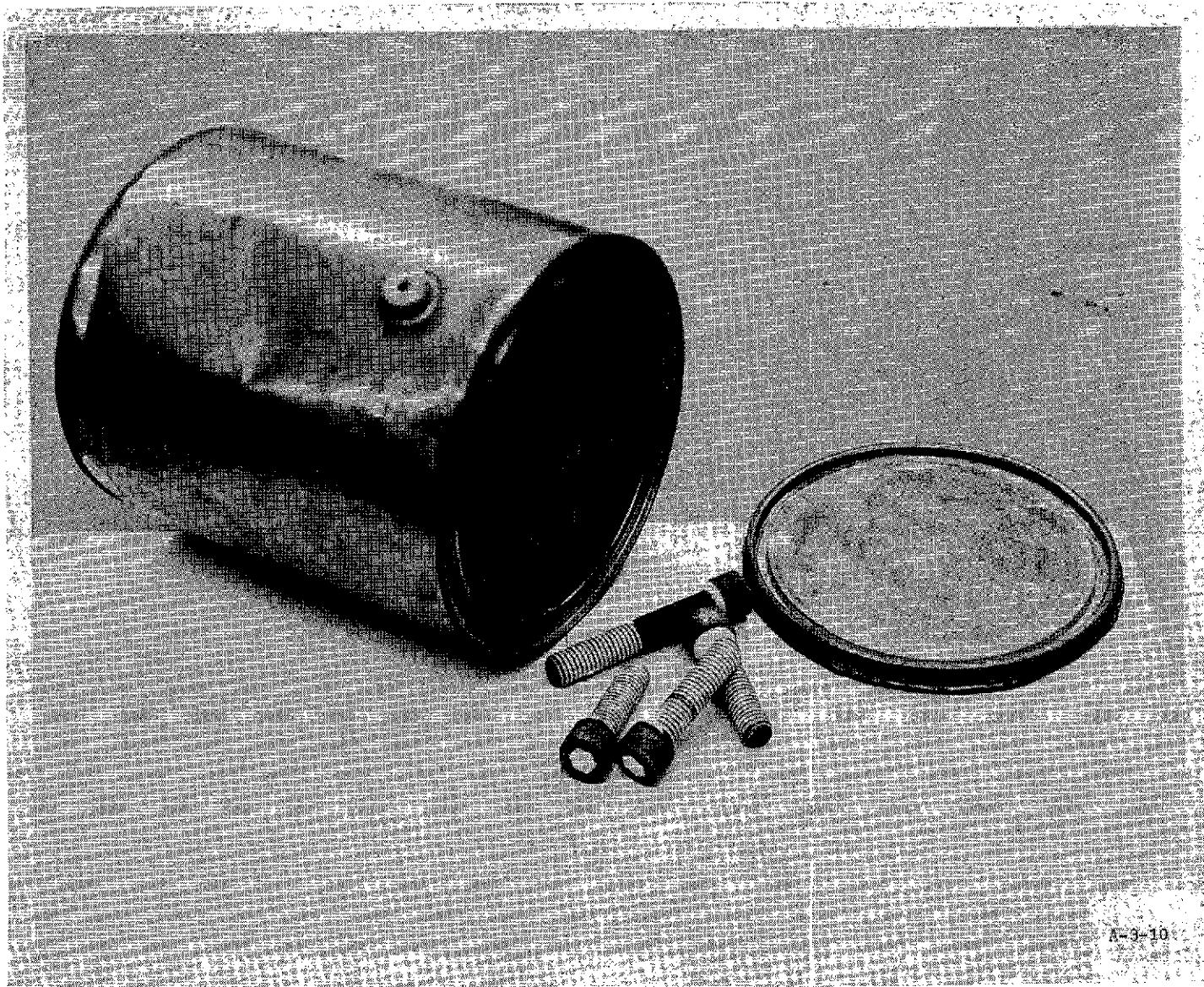

Figure 1. Tumbling Can

General Electric R.T.V. 615:

This material mixed very well and even distribution was nearly achieved without tumbling. The mixed material adhered to itself better than most of the other materials evaluated.

General Electric R.T.V. 615 and R.T.V. 655:

These materials have essentially the same mixing characteristics, mixing satisfactorily in approximately 45 minutes. Both materials also have a low viscosity and wet the Microballoons easily.

Dow Corning Sylgard 182:

Approximately 45 minutes is required for this material to achieve an even distribution, and it adheres to itself very well.

Dow Corning Sylgard 186:

Mixing characteristics are quite good. The resin viscosity is low enough to allow an even distribution of Microballoons. A thorough mix of this system required 45 minutes of tumbling.

Ablative Material No. 325:

Mixing characteristics are difficult to evaluate since an even distribution required 90 minutes of mixing with intermittent stopping of the tumbling action to break up the packed material by hand. An improved tumbling method is required for this material. The material did not exhibit adhesion to itself. Small lumps of resin approximately 1.52 mm (0.06 in.) were found throughout the mixed material.

Aerospace Sealant No. 93-027:

This material was mixed for 75 minutes and could not be effectively mixed using the rotation method alone. Mixing by hand was required to break up lumps of resin. Small lumps of resin were found in this mixture much the same as Ablative Material No. 325.

Only the Isochem 1167 was eliminated as a result of the mixing evaluation because of the large lump size of the unmixed resin. Dow Corning's 325 and 93-027 resins had indications of small flaky resin particles. However, these particles are evenly distributed throughout the mixture and are not known to be objectionable.

All materials, except Isochem 1167 were molded into arc-jet test specimens and delivered to the National Aeronautics and Space Administration for testing.

In-process cure tests. - Test specimens for determining the in-process cure conditions during production could be taken directly from the ablative panels, such as the core drilling at the attach hole locations. These plugs could then be used as the test specimens for each respective panel. An alternate method of obtaining test specimens would be to add another cavity in the mold adjacent to the panel cavity which would be filled and cured simultaneously with the panel. The specimen would be of identical material composition and cure time, and therefore, be totally representative of its panel.

Since special facilities or tooling would be required to evaluate the relatively low physical properties (compression or tensile strengths) to determine cure levels, alternate methods of specimen testing were evaluated.

Electrical cure tests: The Brunswick Corporation utilized the services of Dr. Allen Edison\* to investigate possible methods of determining cure levels by measuring and establishing values of dielectric constant for uncured versus cured ablative material. The three test methods used by Dr. Edison were as follows:

Procedure: Freshly mixed material was packed in a General Radio Insertion Unit, Type 874X. Measurements in accordance with the following test methods were made on the unit immediately after insertion, and again after 4 days.

Method 1. Conductance Measurements

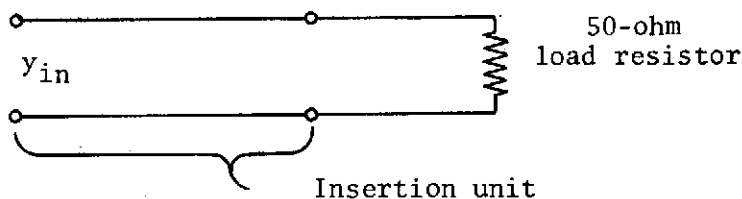

$$f = 250 \text{ mHz}$$

$$y_{in} \text{ (fresh material)} = 14.8 - j 3.0 \text{ m mhos}$$

$$y_{in} \text{ (cured material)} = 14.6 - j 2.6 \text{ m mhos}$$

Results of measurements - Differences are not significant enough to establish a reliable cure test standard.

---

\*Professor of Electrical Engineering, The University of Nebraska, Lincoln, Nebraska (Consultant to the Brunswick Corporation, Technical Products Division, Lincoln, Nebraska)

## Method 2. Vector Measurements

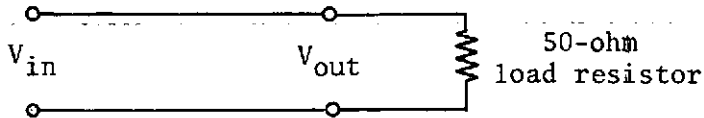

A vector voltmeter was used to measure  $V_{in}$  and  $V_{out}$  at 900 MHz.

New Material  $V_{in} = 15.6 \text{ mV @ } 0^\circ \text{ rad. } (\angle 0^\circ)$   
 $V_{out} = 14.0 \text{ mV @ } -3.059 \text{ rad. } (\angle -172.4^\circ)$

Cured Material  $V_{in} = 15.4 \text{ mV @ } 0^\circ \text{ rad. } (\angle 0^\circ)$   
 $V_{out} = 14.0 \text{ mV @ } -3.059 \text{ rad. } (\angle -175.4^\circ)$

Results of measurements - Differences are not significant enough to establish cure test standards.

## Method 3. Capacitance Measurements

Input capacitance of the unit was measured (Capacitance = 5 pF when air filled).

New Material  $11 - 5 = 6 \text{ pF}$

Cured Material  $11 - 5 = 6 \text{ pF}$

No detectable difference; however, the measurement required the bridge to operate at the extreme low end of its range where accuracy is questionable.

Test results show that Microballoon/silicone resin material is a high quality dielectric material. Dielectric properties do not change significantly during the cure process, and therefore, the dielectric constant is not a good indicator of the state of cure. No further consideration is given to electrical testing methods.

Chemical cure tests: Because it was reasoned that uncured silicone resin would become soluble in various solvents, specimens were placed into a container of Toluol during various stages of cure. This test method showed that uncured specimens broke up and the resin dissolved into the Toluol, whereas cured specimens were not affected. To support this test method, sample specimens, 15.24 cm X 15.24 cm X 5.08 cm (6 in. X 6 in. X 2 in.) were cured with times correlated with the solvent test results and handling properties observed. Specimens cured in accordance with times

test results and handling properties observed. Specimens cured in accordance with times established by the solvent test method could be removed from hot molds without damage and exhibited good strength characteristics when broken. No additional improvement was observed when longer cure times were used. Therefore, this method has been established as a suitable technique for determining the cure level.

Minimum cure time. - As a result of National Aeronautics and Space Administration arc-jet testing, two resin systems were selected for continued evaluation. These materials were:

General Electric R.T.V. 615  
Dow Corning Sylgard 182

The following procedure was used to establish the minimum cure cycle:

Mix a batch of the resin to be evaluated and fill 4 molds having a cavity measuring 5.08 cm X 5.08 cm X 5.08 cm (2 in. X 2 in. X 2 in.). The resin mix is 20% resin weight to 80% Microballoons weight. Preheat an oven to 394° K (250° F) and place all four specimens of a given batch in the oven at the same time. After 15 minutes cure, remove one specimen, cut in half and place in a container of Toluene. If the specimen is cured and does not break up in the Toluene, discontinue the cure cycle of the remaining specimens. If a cure is not obtained after 15 minutes, repeat the test every 15 minutes until a cure is obtained. Start the cure of all specimens as soon as a satisfactory mix is completed.

The minimum cure cycle for General Electric R.T.V. 615, as established by this method, was 45 minutes, and 12 hours was considered maximum for the pot life of this material. The minimum cure cycle for Dow Corning Sylgard #182 was also 45 minutes, although this system would not cure without the application of pressure. Therefore, instead of placing the material in an oven, it was necessary to use a heated press for the cure of this material. Separate batches were mixed and then cured at 15-minute intervals until a complete cure was obtained. Pot life for this material was satisfactory after three months.

Dielectric cure. - Brunswick utilized the services and facilities of the Raybond Electronics Corporation, Norwood, Massachusetts, for this evaluation. Raybond operated the equipment and provided consulting service. The following sequence describes the procedure for molding a 0.0929 m<sup>2</sup> X 5.08 cm (1 sq. ft. X 2 in.) panel by dielectric curing.

Two types of panels were cured in the dielectric mold. One was a "single density", i.e. having the same density throughout the cross-section (Figure 3); the other, a "dual density", i.e., having two densities within the cross-section (Figure 4). In the latter case, the upper 6.35 mm (0.25 inch) had a density of 320.37 kg/m<sup>3</sup> (20 lbs/ft<sup>3</sup>) and the remainder a density of 240.38 kg/m<sup>3</sup> (15 lbs/ft<sup>3</sup>).

The dual-density panel offers a compromise of high density for the ablation layer and low density for the insulation layer. The overall density is somewhat greater than 240.38 kg/m<sup>3</sup> (15 lbs/ft<sup>3</sup>), but the necessary increase in weight is compensated for by the better ablation performance.

1. Materials

- Phenolic microballoons . . . . . Union Carbide  
(BRP-5549)
- Silicone resin system . . . . . Dow Corning  
(2 component) (Sylgard 182)
- Honeycomb . . . . . Hexcel Corporation  
(3/8 HRP GF-11-2-2)
- Liquid Phenolic Resin . . . . . Union Carbide  
(Primer) (BRL-1100)
- Ground Core (40 mesh) . . . . . Brunswick Corporation  
(ground from sheet cork)

Glass Beads

2. Equipment and Tooling

Raybond-designed laboratory generator operating at 15 MHz, with a maximum output of 4 kW.

Raybond-designed laboratory press of I-beam and channel construction, with hand-operated hydraulic jack for pressure.

Dielectric Mold

Improvised Rotating Machine

Paint Can Tumbler

Resin Dip Tray

Pyrometer

3. Molding Procedure

- a. Trim 5.08 cm (2 in.) thick honeycomb to pieces 30.48 cm (12 in.) X 30.48 cm (12 in.) using a band saw.
- b. Fill the resin dip tray with phenolic primer.
- c. Dip the honeycomb into the tray of phenolic primer. Completely submerge and immediately remove from tray. Place two sticks across the edges of the dip tray to rest the honeycomb and allow to drain.
- d. Drain for a minimum of 30 minutes and a maximum of 90 minutes.

e. Prepare the following mixes of material:

Pre-mix 10 parts per hundred of Sylgard 182 resin for both the ablative and insulative sections.

(1) Ablative Charge:  $320.37 \text{ kg/m}^3$  ( $20 \text{ lb/ft}^3$ )

<u>Material</u>	<u>Grams</u>
Pre-mixed 182 resin . . . .	37.60
Phenolic microballoons. . .	37.60
Ground cork (40 mesh) . . .	18.80
Glass microballoons . . . .	94.00

Place materials in a clean container and mix by hand until resin is thoroughly blended with all components.

(2) Insulative Charge:  $240.28 \text{ kg/m}^3$  ( $15 \text{ lb/ft}^3$ )

<u>Material</u>	<u>Grams</u>
Pre-mixed 182 resin . . . .	155
Phenolic microballoons. . .	615

Place materials in can and stir by hand to obtain a general wetting. Then place tumbling bolts in can and close lid. Set tumbler in a lathe and rotate at approximately 38 rpm for 45 minutes or until contents are properly mixed.

- f. Position dielectric mold (Figure 2) in press and attach generator.
- g. Heat upper and lower dielectric mold surfaces to  $460.9^{\circ} \text{ K}$  ( $370^{\circ} \text{ F}$ ) by calrod heaters located in the mold. Disconnect heaters from power source. Heat the side walls of the mold to  $377.6^{\circ} \text{ K}$  ( $220^{\circ} \text{ F}$ ) by the use of the dielectric generator.
- h. Open dielectric mold.
- j. Place ablative charge into mold cavity and spread evenly. Pre-pack all corners and edges and brush excess material toward the edges.
- k. Place spacer (which duplicates honeycomb thickness less 6.35 mm [1/4-inch]) over ablative charge and close mold to mold stops.



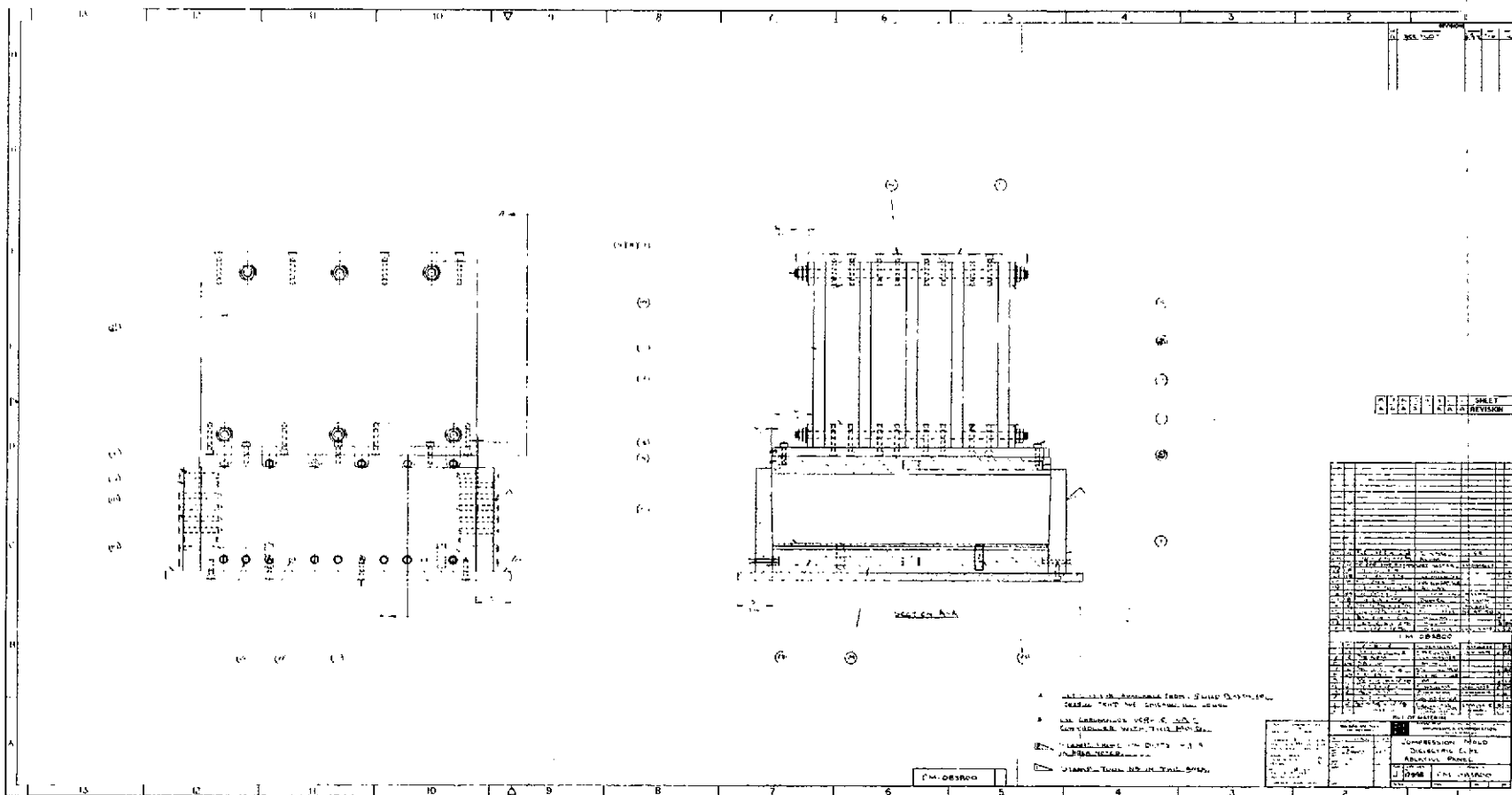
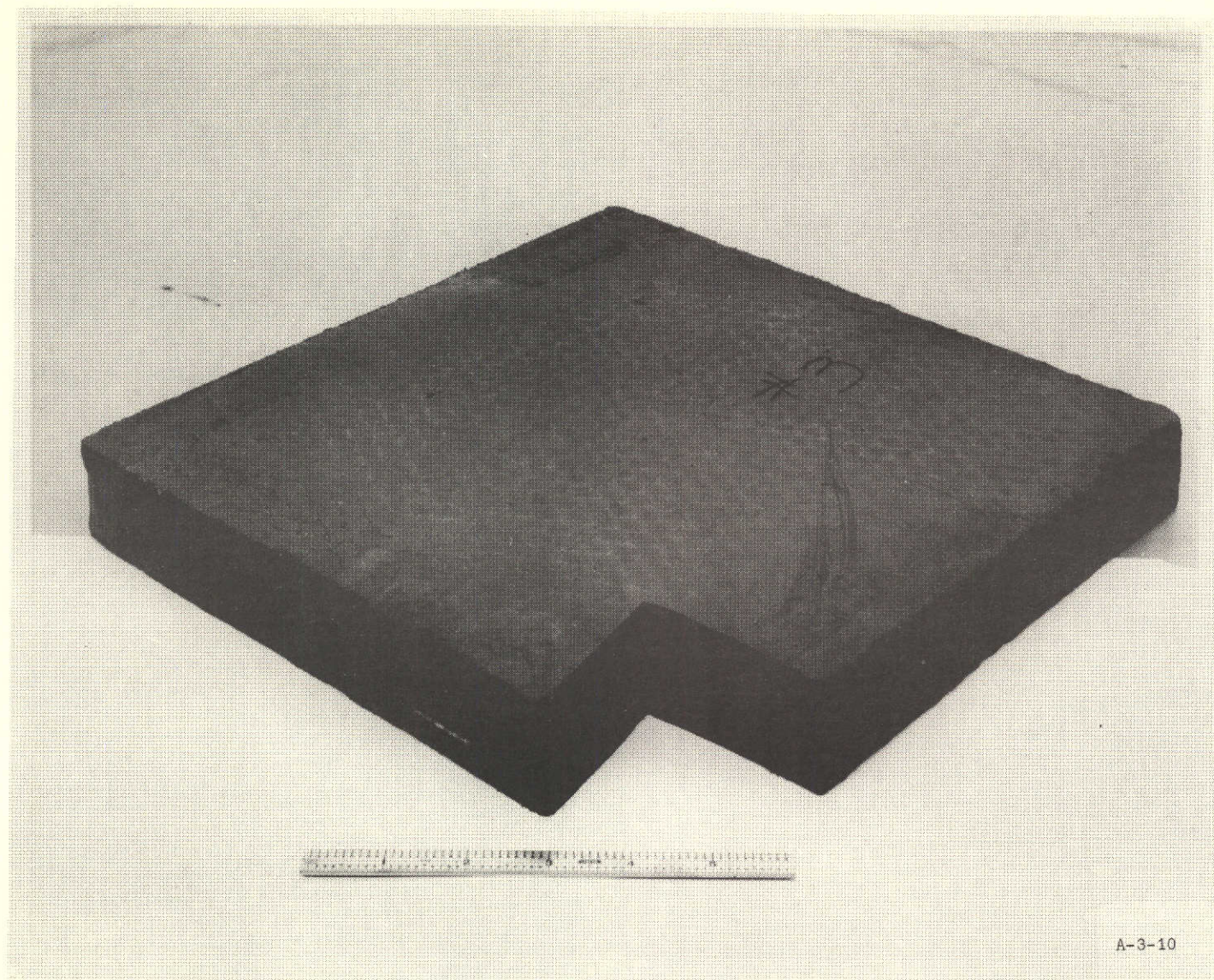

Figure 2  
Compression Mold - Dielectric Cure

- l. Cure for 90 seconds with a generator setting of 4 kV and the ampere setting at 1.0 throughout the cure.
- m. Open press and remove spacer.
- n. Place approximately 250 grams of the insulative charge in the mold cavity. Spread evenly, except brush an additional amount of mix (approximately 12.70 mm [1/2-inch] high X 45°) toward all four sides of the mold and in the corners.
- p. Position the honeycomb core into the mold cavity and press in place by hand.
- q. Fill the mold with the remaining 520 grams of insulative mix. Spread evenly, making sure that all corners and sides are filled.
- r. Close mold to mold stops and cure for 150 seconds. Set generator at 2-3 kV with the starting ampere at 0.9 and gradually increase the setting to 5.5 amperes at the end of cure.
- s. Open mold and remove panel.

Tabular work sheets are presented in Appendix A which include data obtained while dielectrically curing 15 ablative test panels using the above procedure, except for variations in generator load and time.

Most of the dielectrically-cured ablative test panels used a Micro-balloon/resin (M/R) mix which was three months old, while other test panels were made from M/R mixes only one day old. The results of all panels was essentially the same, i.e., no appreciable change in cure characteristics due to aging. The primary cause of soft edges and sides was insufficient pressure, thus creating the need to place extra material in those areas prior to closing the mold. This same phenomenon was observed while establishing an in-process technique for determining the state-of-cure of Sylgard 182. The extent of shelf life ablative mixes containing Sylgard 182 has not been determined, although three months appears to be an exceptionally long time for a two-part silicone resin.



A-3-10

Figure 3  
Single-Density Panel -  
Dielectrically Cured

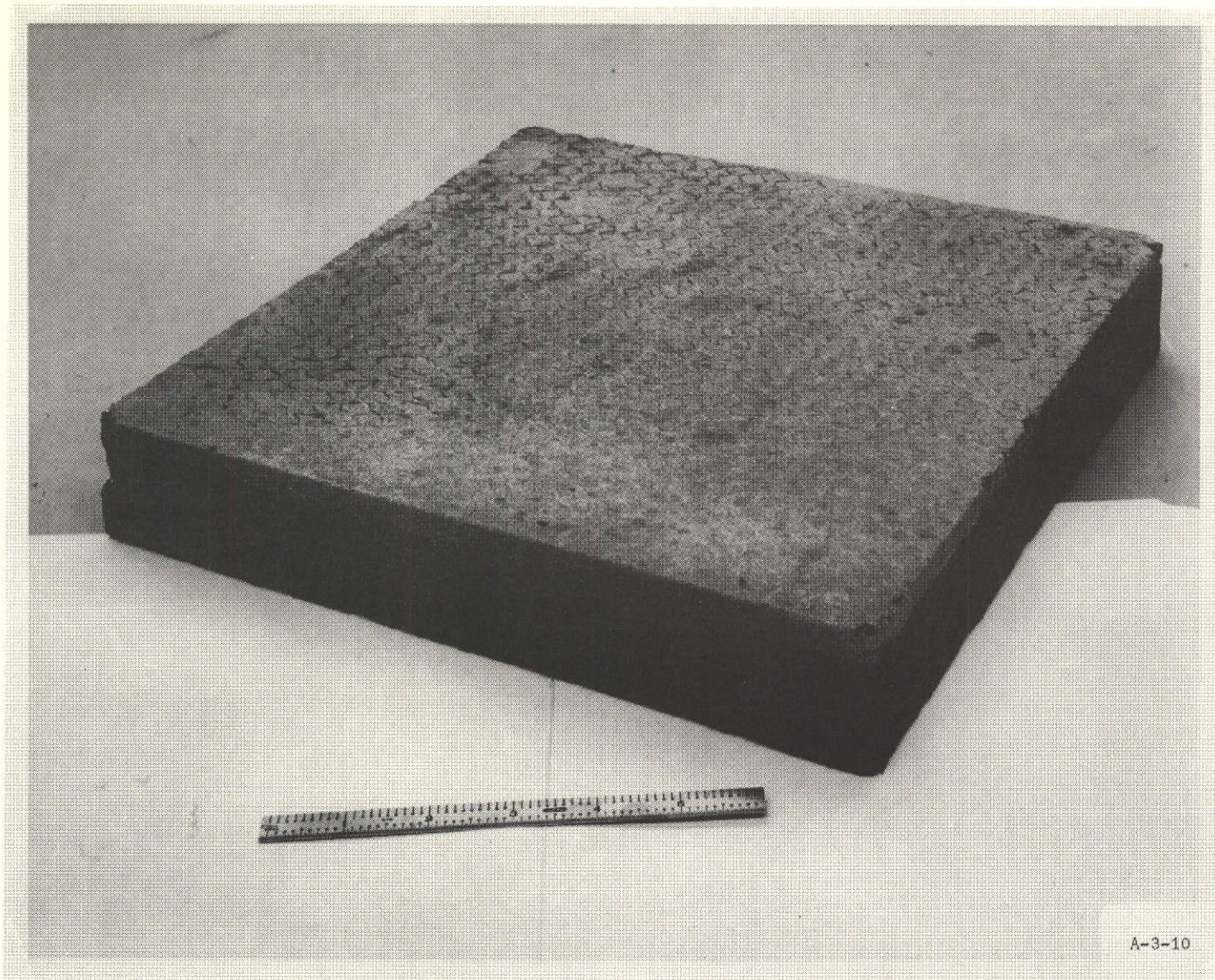

Figure 4  
Dual-Density Panel -  
Dielectrically Cured

## Task 2

### Resin Dispersement and Face Sheet Evaluation

The principal objective of this task was to vary the density through the thickness of the panel to improve thermal and mechanical performance, and to evaluate the use of local reinforcement around the attach point. Specific objectives were directed toward:

- (i) Using the best cost/performance system from Task 1, evaluate dual-density panels. Evaluation was to vary the resin content through the thickness such that a density of approximately  $320.37 \text{ kg/m}^3$  ( $20 \text{ lb/ft}^3$ ) is attained in the outer 6.35 mm (1/4-inch) of the panel thickness using a much lower density material in the inner portion of the panel. The overall density of the panel including a honeycomb reinforcing material was not to exceed  $240.37 \text{ kg/m}^3$  ( $15 \text{ lbs/ft}^3$ ).
- (ii) Establish a method for compression molding an integral skin on the panel outer surface to improve handleability and limit moisture penetration.
- (iii) Evaluate film adhesive systems for bonding localized face sheets at the panel attachment points.

#### 1. Materials

Honeycomb Core (9.53 mm [3/8] HRP GF-11-2.2)	Hexcell Corp.
Liquid Phenolic (BRL-1100)	Union Carbide
Resin (Primer)	
Phenolic Microballoons (BRP-5549)	Union Carbide
Silicone Resin (Sylgard 182)	Dow Corning
Silicone Resin (RTV 615)	General Electric
Powdered Cork (ground from sheet stock)	Brunswick Corp.
Glass Beads (BJO 0930)	Union Carbide
MS-122 Fluorocarbon Parting Agents	Miller-Stephenson Chemical Company, Inc.

PRECEDING PAGE BLANK NOT FILMED

## 2. Equipment and Tooling

Blue M Air Circulating Electric Oven

Pasadena Hydraulic Inc., 45.36 Mg (50-ton) Laboratory Press

Allas 25.4 cm (10-inch) Band Saw

One 3.785 dm<sup>3</sup> (1-gallon) Plastic Container

Resin Dip Tray

Flexible Spatula

Aluminum Test Panel Mold

Trichloroethane Dip Degreasing Tank

## 3. Procedure

- a. Trim honeycomb core to 15.24 X 15.24 X 5.08 cm (6 in. X 6 in. X 2 in.). The trimmed core will weigh approximately 44 grams.
- b. Dip honeycomb core into trichloroethane dip tank for cleaning and remove from tank.
- c. Dip honeycomb core into dip tank filled with phenolic primer until the core is completely submerged, then remove from tank and allow to rest on sticks placed across the edges of tank. Allow the core to drain and flash off solvents for 30 minutes to 90 minutes. Weight of honeycomb core coated with primer will be approximately 55 grams.
- d. Prepare ablative mixture: 320.37 kg/m<sup>3</sup> (20 lb/ft<sup>3</sup>)
  - (1) Premix 9.43 grams of silicone resin R.T.V. 615 or Sylgard 182, whichever is to be evaluated, in accordance with the suppliers' instructions.
  - (2) Weigh out 9.43 grams of phenolic microballoons.
  - (3) Weigh out 4.72 grams of powdered cork.
  - (4) Weigh out 23.60 grams of glass beads.
  - (5) Mix all dry components together in a 3.785 dm<sup>3</sup> (one gallon) container. Place the silicone resin in another 3.785 dm<sup>3</sup> (one gallon) container and slowly add the dry powder mix, stirring with a flexible spatula until the entire mixture is wet.

- e. Prepare insulative mixture:  $136.15 \text{ kg/m}^3$  ( $8.5 \text{ lbs/ft}^3$ )
- (1) Premix 28 grams of silicone resin R.T.V. 615 or Sylgard 182, whichever is being evaluated, and mix in accordance with the suppliers' instructions.
  - (2) Weigh out 112 grams of phenolic microballoons.
  - (3) Place the silicone resin into a  $3.785 \text{ dm}^3$  (one gallon) plastic container and begin stirring, using a flexible spatula. At the same time, add a small amount of phenolic microballoons to the resin until a good mix is obtained. Repeat this three more times until all microballoons have been added to the silicone resin.
- f. Spray coat inside surface of the mold cavity with parting agent.
- g. Place test panel mold in press and heat to  $394.3^\circ \text{ K}$  ( $250^\circ \text{ F}$ ).
- h. Open mold and fill with ablative mix. Spread out evenly to ensure a uniform layer after molding. Place spacer (equal to honeycomb thickness, less  $6.35 \text{ mm}$  ( $1/4$ -inch) over ablative charge.
- j. Close mold to the mold stops and partially cure at  $394.3^\circ \text{ K}$  ( $250^\circ \text{ F}$ ) for 5 minutes.
- k. Open press and remove parts.
- i. Place one-third of the insulative mix into mold cavity followed by the honeycomb core, followed by the remaining two-thirds insulative mix.
- m. Close mold and cure at  $394.3^\circ \text{ K}$  ( $250^\circ \text{ F}$ ) for 45 minutes.
- n. Open mold and remove part. Figure 5 shows a typical panel in the mold.

Evaluation of ablative mixtures. - Various combinations of materials were mixed and evaluated to arrive at the most suitable ablative surface. Table 7 shows combinations of ablative mixes evaluated. On occasion, four ablative mix combinations were molded on the surface of a single panel to reduce molding time and accelerate the test program. The appraisal was based upon the ability of each mix to wet out and mold satisfactorily; have a surface which is hard and firm and could be handled without crumbling; have satisfactory ablative characteristics; and provide suitable insulative properties without supporting combustion.

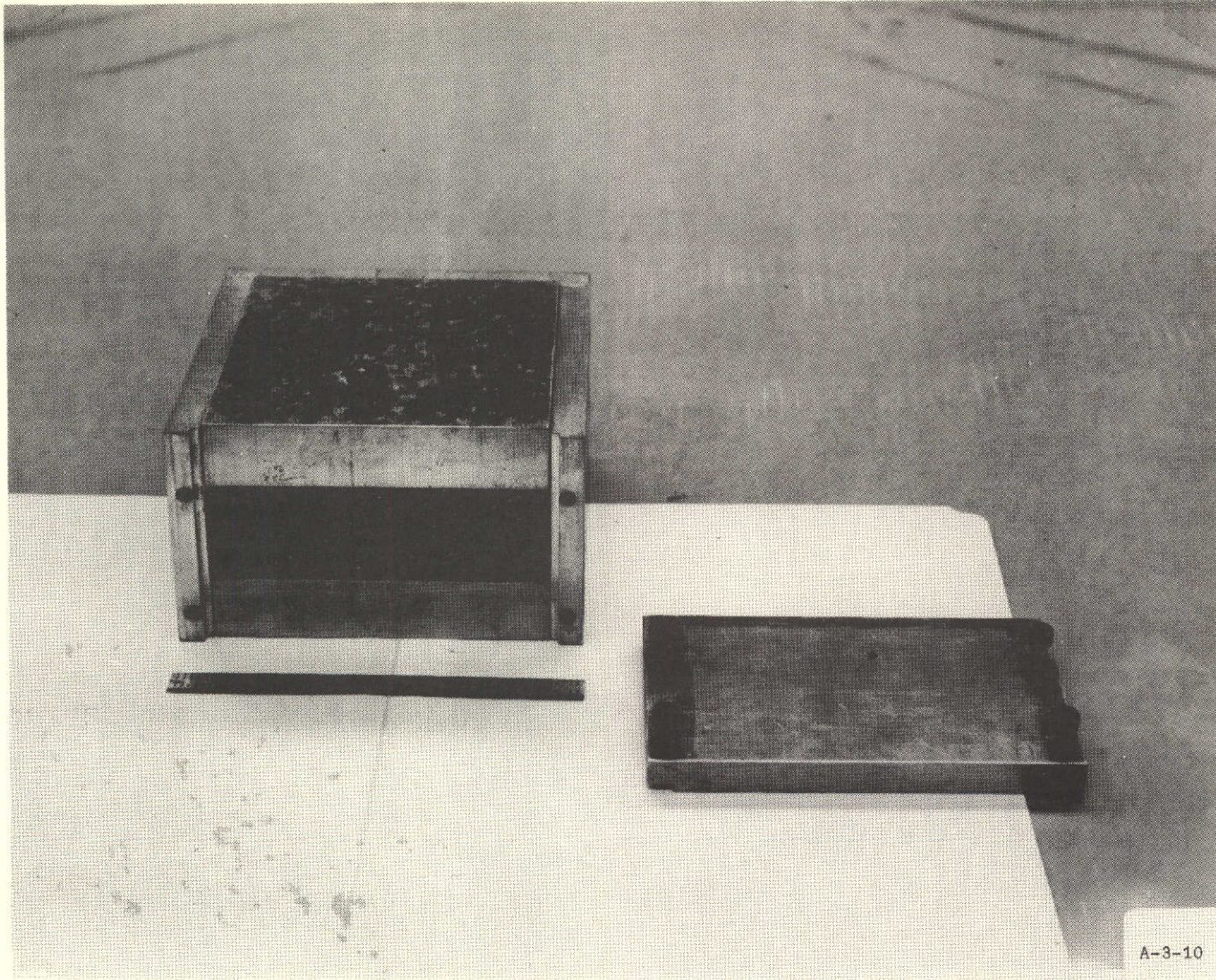

Figure 5.  
Ablative Test Panel in Mold  
with End Panel Removed



TABLE 2  
MATERIAL COMBINATIONS  
HIGH-DENSITY  
ABLATIVE MIXTURES

Figures show percentages of each material used with silicone resin first, phenolic microballoons second, powdered cork third, and glass beads fourth.

60/40/0/0	30/60/10/0
60/30/10/0	30/50/10/10
60/20/10/10	30/40/10/20
	30/30/10/30
50/40/10/0	30/20/10/40
50/30/10/10	
50/20/10/20	20/80/0/0
	20/70/10/0
40/50/10/0	20/60/10/10
40/40/10/10	20/50/10/20
40/30/10/20	20/40/10/30
40/20/10/30	20/30/10/40
40/30/20/10	20/20/10/50

Brunswick initiated an in-house test method of applying the flame of an oxygen-acetylene torch to the surface of the test panel and observing the results (Figure 6). The flame temperature was estimated to be 1922<sup>o</sup>-2477<sup>o</sup> K (3000-4000<sup>o</sup> F.) and was always placed the same distance from the test specimen.

A typical panel after flame test is presented in Figure 7. Note the surface condition of the lower right-hand section. The ablative mixture of this section was 20/20/10/50, which was considered the best ablative mixture evaluated. After testing, the surface of this mixture did not show resin blisters or swelling, no large cracks where the material had separated from the honeycomb core, and exhibited minimum charring. Subsequent tests performed by NASA supported this assessment.

Test results indicated that higher percentages of silicone resin increases surface swelling or blistering and burning, while cork and glass beads reduce the swelling and burning. Percentages greater than 10% cork appear to increase surface cracking.



Figure 6  
Flame Test of Ablative Panel



A-3-10

Figure 7  
Ablative Test Panel After Flame Test

Evaluation of insulative mixtures. - Material composition of the ablative mixtures were varied to improve ablative characteristics, but were always maintained at 20 lb/ft<sup>3</sup> densities. Insulative mixtures varied the silicone-to-phenolic microballoon ratios to obtain the lowest overall panel density that would still function as a satisfactory insulator.

As the ratio of silicone resin is increased, wetting is improved, density is greater, and volume decreases. Conversely, as the ratio of silicone resin is lowered, the ability to wet and hold the phenolic microballoons is reduced, volume increases, and density decreases for a given volume. Since the main objective as to reduce panel density, while still retaining the other values, efforts were directed toward reducing the silicone resin content in the insulative mixture. Subsequent investigations revealed that 0.5% of Union Carbide's Silane A-174, when added to the resin, assisted in the wetting of phenolic microballoons. This improved wetting condition permitted the lowest density insulative mixture of 112.0 kg/m<sup>3</sup> (7 lbs/ft<sup>3</sup>).

Subsequent testing by Brunswick and NASA found this low-density insulative material to support combustion at operational temperatures and was, therefore, unsatisfactory. The lowest density insulative material that would not support combustion was a mixture of 20% silicone resin to 80% microballoons, with a resultant density of 136.21 kg/m<sup>3</sup> (8.5 lbs/ft<sup>3</sup>).

The best dual-density panel fabricated met the five basic evaluation criteria as follows:

1. Handleability

The ablative surface was always very smooth and fairly hard. The surface could be scratched with a hard, sharp object but no problems were encountered during normal handling.

2. Ablative Performance

Perhaps the strongest of all the objectives, ablation proved to be very slow and deterioration was always minimal. Surface cracks, if any, were very small. Swelling was negligible.

3. Insulative Properties

The insulation layer prevented most of the heat from transferring through to the back surface. Temperatures in the range of 310.9<sup>o</sup> K (100<sup>o</sup> F.) to 338.7<sup>o</sup> K (150<sup>o</sup> F.) were noted after two minutes of burn testing.

4. Combustability

With the 136.156 kg/m<sup>3</sup> (8.5 lbs/ft<sup>3</sup>) density material used as an insulation layer, no combustion was noted after extended burns up to five minutes at 1,366<sup>o</sup> K (2,000<sup>o</sup> F).

## 5. Weight Density

Dual-density panels fabricated as described would have a density of 193.82 kg/m<sup>2</sup> (12.1 lbs/ft<sup>3</sup>).

Integral skin. - Consideration was given to compression molding an integral silicone resin skin on the outer panel surface to improve handleability and limit moisture penetration. The evaluation consisted of brushing several successive coats of silicone resin onto the ablative surface of the panel, allowing each coat to partially cure prior to the next coating. The silicone resin soaked into the ablative material and formed a firm (rubbery) surface when cured.

Test samples were weighed, placed in a tray of water at room temperature, covered to prevent evaporation, allowed to sit for 24 hours, and then removed and re-weighed. Moisture penetration revealed an approximate 4 to 5% increase in material weight.

The phenolic primer resin used to coat the honeycomb core was also evaluated as a skin coating, but moisture penetration results were greater than with the silicone resin skins. An approximate 5 to 8% weight increase was attributed to moisture penetration when subjected to the same test.

A dual-density panel with no skin coating was subjected to the same test and found to absorb moisture at an approximate weight increase of 10%.

Tests were run on dual-density panels with each of the above-mentioned skin materials to determine the effects of thermal heating. The silicone resin bubbled and swelled excessively, and the phenolic primer swelled and flaked off the surface very easily.

Bonding localized face skins. - Thin face skins, 2.54 mm (0.010-inch) thick, were bonded to ablative panel test specimens using both film and liquid adhesives. These specimens were prepared and proof-tested by tensile testing in accordance with the following procedures.

### 1. Materials

Epon 828 . . . . .	Standard Epoxy Resin (Shell Chemical Co.)
Curing Agent "Z" . . . . .	Standard Curing Agent for Epoxy Resin (Shell Chemical Co.)
Curing Agent No. 140 . . . . .	Standard Curing Agent (General Mills Chemical Inc.)
FM 123-4 Adhesive . . . . .	Standard Adhesive Film (American Cyanamide Co., Inc.)
1581 Fabric . . . . .	Glass Cloth weighing 305 g/m <sup>2</sup> (9 ounces per yd <sup>2</sup> )

## 2. Equipment and Tooling

Riehl Tensile Testing Machine

Tensile Test Bar

Band Saw

## 3. Procedure

- a. Saw cured ablative panel into small specimens 2.54 cm X 2.54 cm X 5.08 cm (1 in. X 1 in. X 2 in.).
- b. Lightly sand the top and bottom surfaces of the specimens to expose the honeycomb core evenly across the surface.
- c. Use either the film adhesive No. 123-4 or Epon 828 liquid adhesive and 140 curing agent. If Epon 828 adhesive is used, weigh out 100 parts per hundred of the 828 to 33 parts per hundred of 140 curing agent. Place both materials into a clean container and mix thoroughly until complete blending is obtained.
- d. Place adhesive between the ablative specimen and tensile test bars (Figure 8) and hold all members together with a "C"-clamp for pressure. Use only enough pressure to the assembly to ensure intimate contact of the bonding surfaces.
- e. Cure the Epon 828/140 adhesive for one hour at 394.3° K (250° F). Cure the FM 123-4 adhesive for 1-1/2 hours at 394.3° K (250° F).
- f. Remove "C"-clamp and place specimen in Riehl Tensile Machine. Perform tensile tests and record yield strengths.

Test results. - Results of the tensile tests are presented in Table 8.

The average tensile bond strength of liquid Epon 828 and 140 hardener is 37.23 N/cm<sup>2</sup> (54 psi); while the tensile bond strength of the adhesive film FM 123-4 averaged 33.09 N/cm<sup>2</sup> (48 psi). Both adhesive systems were found to be acceptable for this application.

NOTE: No elevated temperature bond line tests were run during these evaluations as the intent here was to prove the adequacy of the bond processes rather than optimize an adhesive system. Standard adhesives are available capable of performing at the bond line temperatures anticipated and further tests should ultimately be carried out to optimize on a specific adhesive.

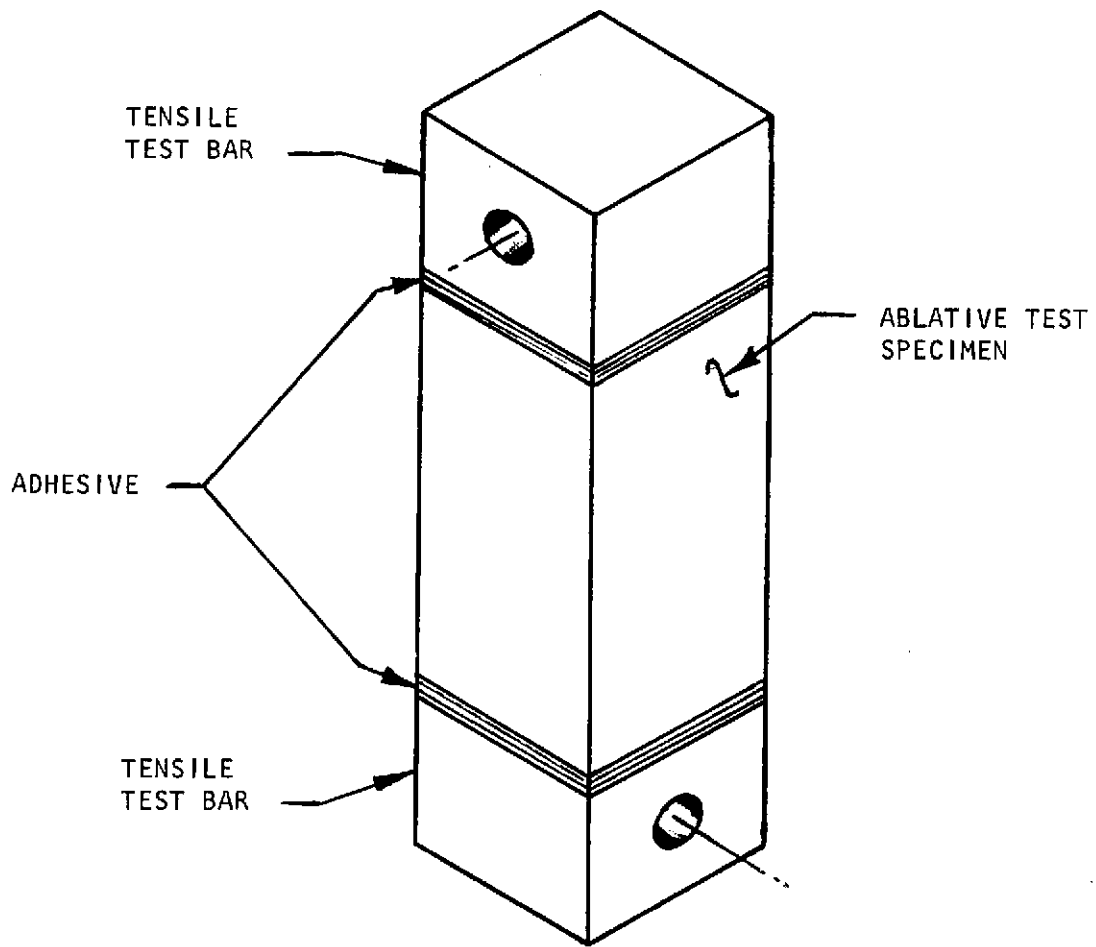

Figure 8  
Tensile Test Specimen

TABLE 3

TENSILE TEST RESULTS  
(LOCALIZED FACE SKINS)

ADHESIVE	BOND STRENGTH	
	N/cm <sup>2</sup>	psi
Epon 828/140	35.85	52.0
Epon 828/140	37.92	55.0
Epon 828/140	31.71	46.0
Epon 828/140	43.43	63.0
Average	37.23	54.0
FM 123-4	22.75	33.0
FM 123-4	38.61	56.0
FM 123-4	40.67	59.5
FM 123-4	29.64	43.0
Average	33.09	48.0



### Task 3

#### Feasibility Study of Low Weight, Inexpensive Reinforcement Matrix

The principal objective of Task 3 was to evaluate the feasibility of replacing the honeycomb matrix of ablative panels with a lighter, less expensive, fiberglass roving. This concept utilized single, stiff, resin-coated, glass roving strands oriented perpendicular to an integrally-woven flexible face sheet. Specific objectives were to:

- (i) Fabricate samples of the support network by using a simple mock-up needling device to lace the strands into the cloth face sheet.
- (ii) Mold sub-scale ablative panels using this support concept, and submit specimens to NASA for arc-jet testing.

Fabrication. - Test specimens, 15.24 cm X 15.24 cm X 5.08 cm (6 in. X 6 in. X 2 in.) were fabricated in accordance with the materials, equipment and procedures listed below:

#### 1. Material

Phenolic microballoons . . . . .	Union Carbide (BRP-5549)
Silicone resin system . . . . .	Dow Corning (Sylgard 182)
Glass Fabric . . . . .	Hess, Goldsmith & Co. (Style 112/38)
Roving/Resin . . . . .	Brunswick Roving (12-end S-glass roving and epoxy)
MS-122 Fluorocarbon Parting Agent . . .	Miller-Stephenson Chemical Co., Inc.

#### 2. Equipment and Tooling

Blue M Air Circulating Electric Oven  
Pasadena Hydraulic Inc. 50-ton Laboratory Press  
Flexible Spatula  
Aluminum Test Panel Mold

### 3. Procedures

- a. Pre-mix 57 grams of Sylgard 182 silicone in accordance with suppliers' instructions.
- b. Weigh out 226 grams of phenolic microballoons.
- c. Place the resin in the tumbling can and begin stirring with a flexible spatula. At the same time, add approximately one-fourth of the phenolic microballoons to the resin and stir until the phenolic microballoons are wet. Then pour the remaining phenolic microballoons into the tumbling can and snap the lid in place. Secure the tumbling can in a lathe to complete the mixing operation. Rotate for 45 minutes at 38 rpm.
- d. Trim fiberglass cloth to dimensions shown in Figure 9 (16.5 cm X 16.5 cm [6-1/2 in. X 6-1/2 in.]). Thread preimpregnated roving through the roving assembly fixture as also shown in Figure
- e. Lightly brush a coating of Sylgard 182 silicone resin over the fiberglass cloth face sheet.
- f. Place in an oven and cure for 45 minutes at 394.3° K (250° F).
- g. Remove from oven and cut strands of roving from the assembly fixture.
- h. Mount ablative test panel mold in a press and heat to 394.3° K (250° F).
- j. Open mold, spray inside with MS-122 parting agent, and place the roving/skin assembly into the mold cavity, with the skin down.
- k. Gently sprinkle the silicone resin/phenolic microballoon into the mold cavity to evenly fill the spaces between roving strands.
- l. Close mold slowly and cure at 394.3° K (250° F) for 45 minutes.
- m. Open mold and remove the test specimen.

Discussion. - Test specimens made from the roving strand reinforcement matrix were arc-jet tested by NASA and found to be inferior to those ablative panels having a honeycomb core matrix. The ablative surface showed considerable ablation and surface cracking.

Another approach considered was a combination of honeycomb core and the roving strand reinforcement as shown in Figure 10. This type of reinforcement had an outer ablative surface which was reinforced with honeycomb

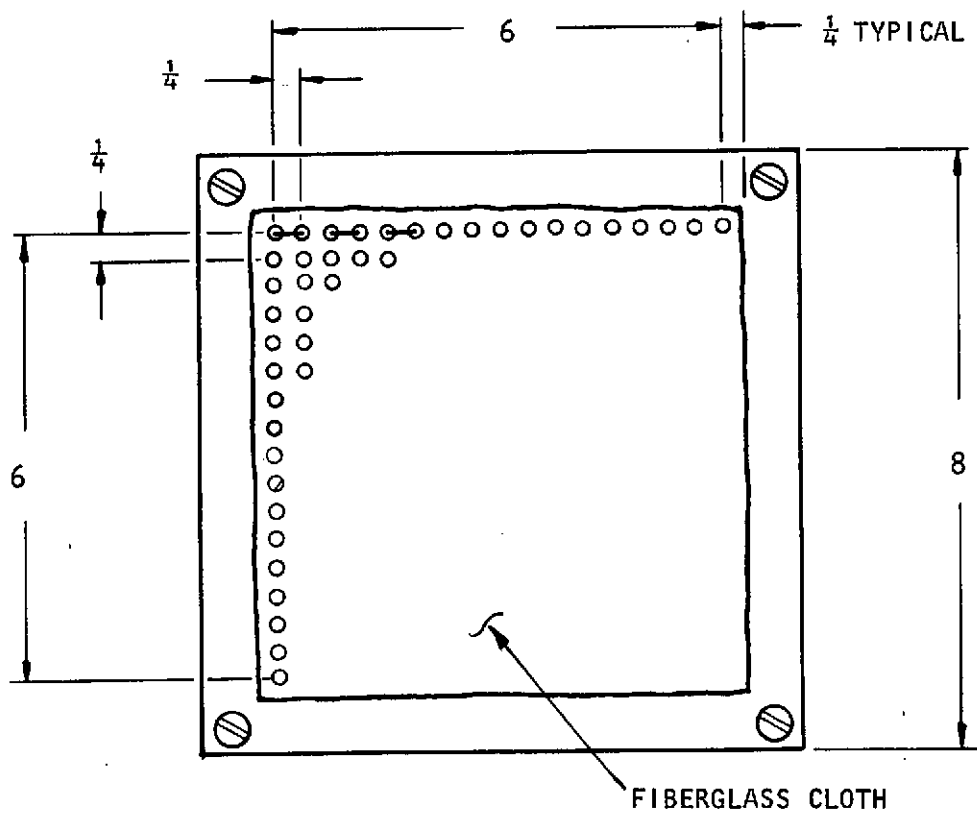
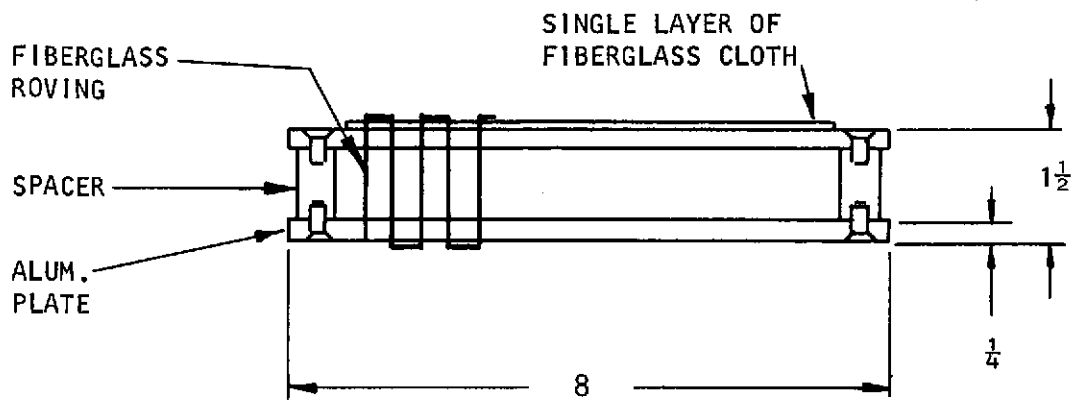

Figure 9  
Roving Assembly Fixture

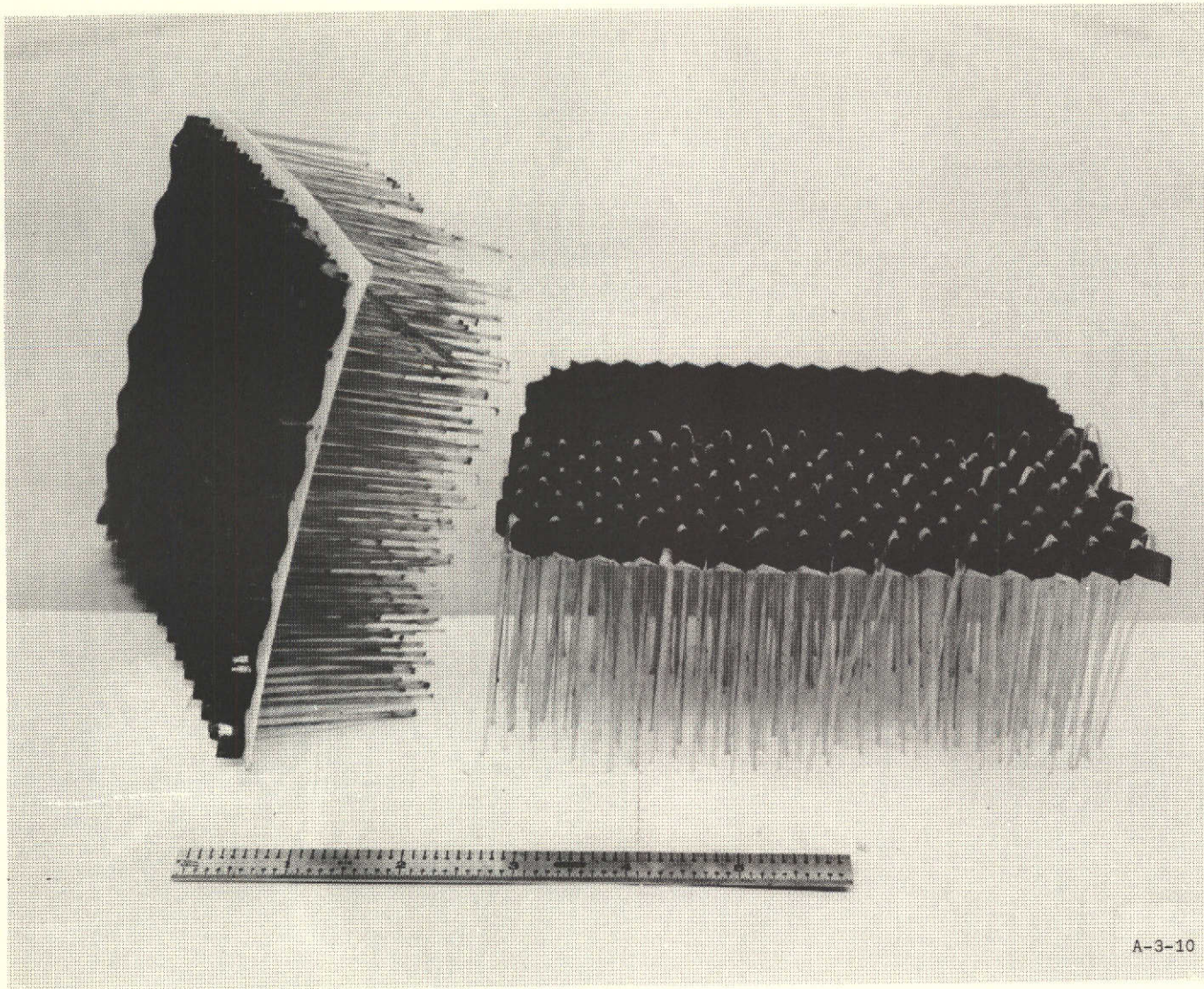
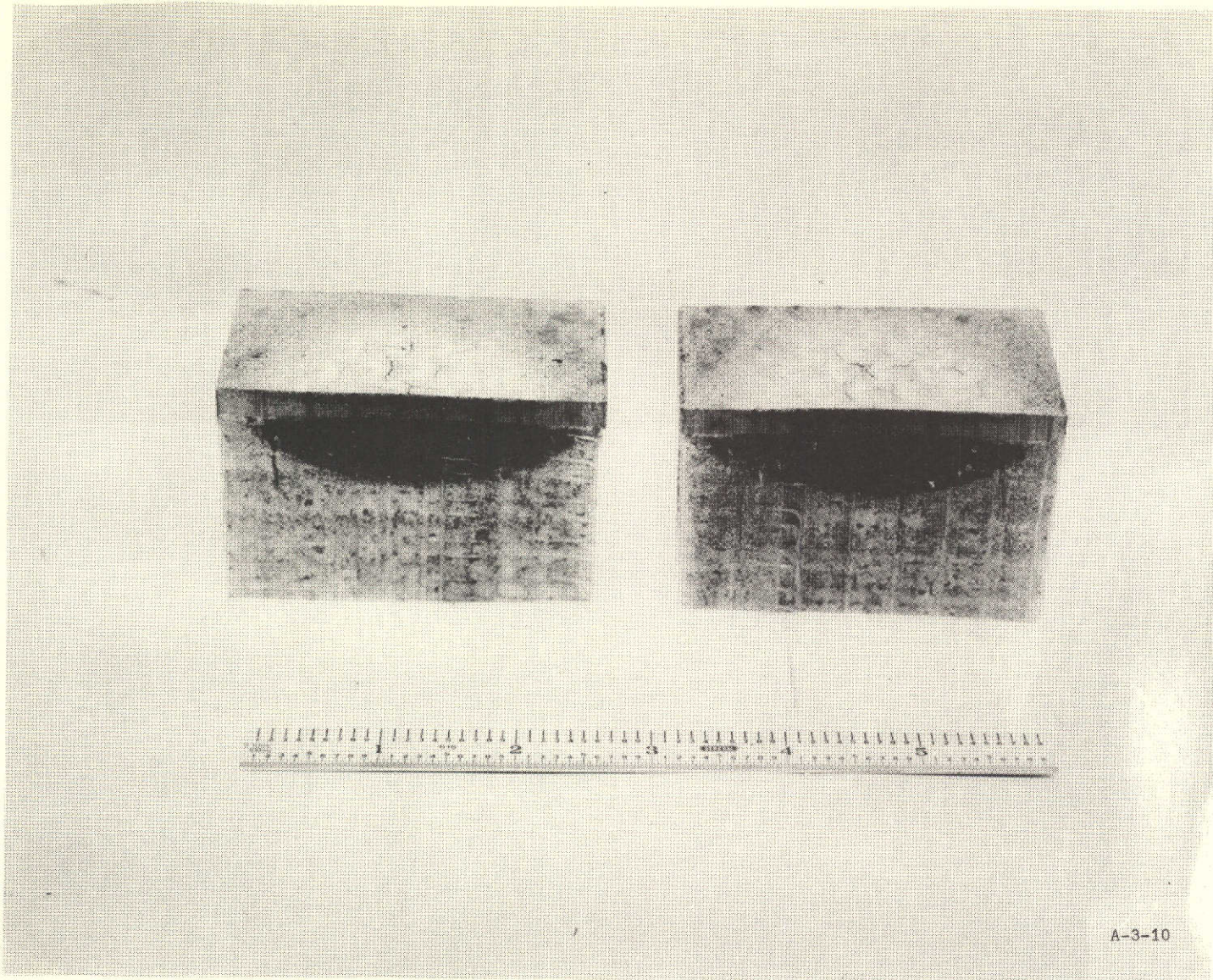

Figure 10  
Combination Reinforcement -  
Honeycomb Core/Roving Strand

core and filled with a resin/microballoon mixture. The lower insulative section was reinforced with urethane foam. Oxygen acetylene flame tests performed by Brunswick caused the insulative section to char and shrink away from the ablative section as shown in Figure 11, which proved this approach to be ineffective.

A mock-up needling device (Figures 12 and 13) was designed and fabricated to develop a production machine for putting roving strands into a suitable reinforcement assembly. Because of the deficiencies found in this type of reinforcement, the machine was never perfected for production capabilities.



A-3-10

Figure 11  
Combination Reinforcement - Dual-Density  
Resin/Microballoon/Urethane Foam

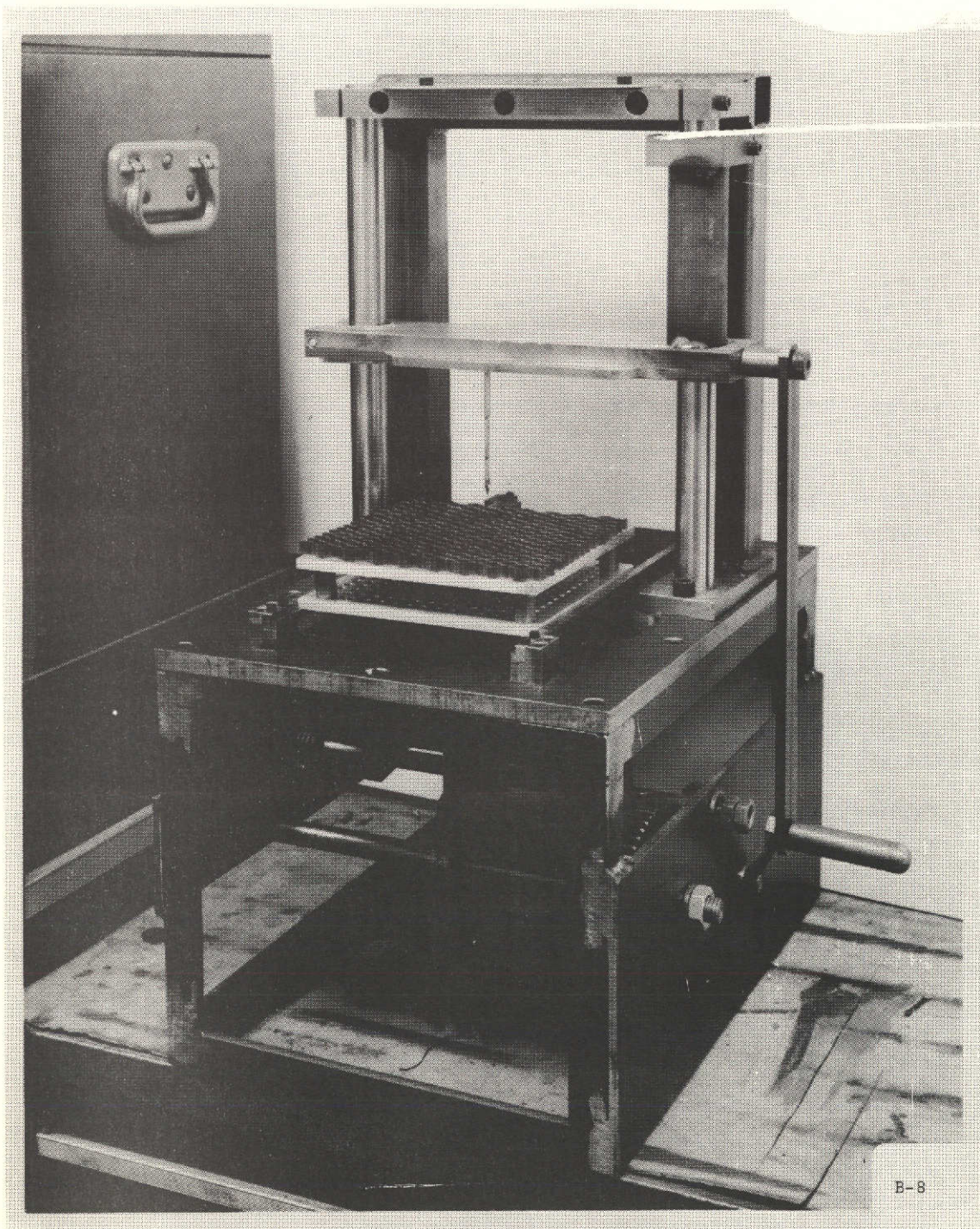

Figure 12  
Roving Strand Needling Machine  
(Developmental)





## Task 4

### Large Panel Fabrication

The principal objective of this task was to design and fabricate a dielectric mold-cure fixture suitable for making a 61 cm X 122 cm X 5.08 cm (2 ft. X 4 ft. X 2 in.) flat panel. Only one such panel was to be delivered, using the optimum composition derived from the previous work. Specific objectives were directed toward:

- (i) Establish a design criteria for the mold-cure fixture.
- (ii) Evaluate dielectric curing as applied to large scale panels.
- (iii) Evaluate the finished panels and define and project solutions to any unresolved problems.
- (iv) Project costs for production quantities of panels made using this dielectric curing method.

The large panels were composed of 20% Sylgard 182 resin by mass and 80% phenolic Microballoons by mass. The mixture was to be loaded into a honeycomb reinforcement and cured with the resulting density of the panel to be  $240.38 \text{ kg/m}^3$  ( $15 \text{ lbs/ft}^3$ ). This type of panel was to be cured using a combination heating source of a dielectric generator and electrically heated mold. Through the previous subscale work Brunswick concluded that a 100 ton press combined with a 10 KW dielectric generator were needed to fabricate the panels. A press meeting these requirements was located at Ingram Plywoods, Thomasville, North Carolina.

#### Mold Design

The design of the mold (Figure 14) was dictated by many influencing factors. The most significant of these were as follows:

- (i) Non-conductive materials were needed between the upper and lower platens.
- (ii) Insulation was required between the platens and the press.
- (iii) Structural design capable of withstanding  $68.94 \text{ N/cm}^2$  (100 psi) pressure was needed.
- (iv) Electric heaters were needed in the platens.
- (v) Removal of the panel from the mold without damaging it was required.

All of these factors were incorporated into the mold design. High strength fiberglass reinforced epoxy was used for the walls of the mold. All joints were fastened with Nylon bolts. The electrical separation of the aluminum platens from the press was also accomplished with fiberglass reinforced epoxy laminated sheet arranged in a criss-cross

pattern both below and above the platens. Resistance type electric heaters were built into the platens. Controlling circuitry designed for regulation of platen temperatures was connected to the heaters. Removal of the panel from the mold was accomplished by removing one wall and pulling the panel out on a thin aluminum sheet.

### Fabrication Procedure

The following sequence describes the procedures used in fabricating one (1) ablative panel 51 cm X 122 cm X 5.08 cm (2 ft. X 4 ft. X 2 in.) by means of a dielectric heated press.

#### 1.0 Materials

Phenolic Microballoons	.....	Union Carbide (BRP-5549)
Silicone resin system (2 component)	.....	Dow Corning (Sylgard 182)
Honeycomb	.....	Hexcel Corp. (3/8 HRPGF-11-2.2)
Liquid phenolic resin (Primer)	.....	Union Carbide (BRL-1100)
Mold Release	.....	Miller Stephenson (MS-122)

#### 2.0 Equipment & Tooling

Press Mfg. Co. designed high frequency press operating at 5 to 6 MHz, maximum output of 30 KW, and maximum closing pressure of 100 tons.

Dielectric Mold

Resin/Microballoon Tumbler

Trichloroethane Vapor Degreasing Tank

Primer Dip Tank

Pyrometer

#### 3.0 Molding Preparation

##### 3.1 Prepare resin/Microballoon mix.

- 3.1.1 Add 147.2 gms hardener to 1324.8 gms Sylgard 182 resin. Stir thoroughly.

- 3.1.2 Weigh out 5808 gms of dried Microballoons.
- 3.1.3 Add the resin and hardener to the Microballoons in a 55-gal. drum and rotate until a homogeneous mix is obtained. Place tumbling bolts in drum to assist in mixing process.
- 3.1.4 Remove from drum and package in an airtight plastic bag. Tag identify bag M/R Mix.

NOTE: This resin/Microballoon mix was prepared approximately 90 days prior to its use in molding the panels.

### 3.2 Prepare honeycomb

- 3.2.1 Trim 5.08 cm (2 in.) thick honeycomb into pieces 60.96 cm X 121.92 cm (24 in. X 48 in.) using a carbide band saw.
- 3.2.2 Clean the core with an air gun to remove all loose dust.
- 3.2.3 Degrease the core in a vapor degrease tank.
- 3.2.4 Remove core from degrease tank without touching with bare hands. Place in an airtight plastic bag and seal.

## 4.0 Molding Procedure

- 4.1 Install mold into press and begin heating platens.
- 4.2 Clean mold with cleaning solvent. Apply a light coat of MS-122 mold release.
- 4.3 Fill the primer dip tank with phenolic resin.
- 4.4 Unpackage the prepared honeycomb and dip into the tank. Completely submerge core and immediately remove it. Lay core on paper towels to absorb the excess primer. Move the core to clean paper towels as they become soaked. Allow core to drip dry a minimum of 30 minutes and a maximum of 90 minutes.
- 4.5 After upper and lower platens of mold reach 460.9° K (370° F) disconnect all electrical wiring running to the heaters. Close mold and heat side walls to 377.6° K (220° F) by the use of the dielectric generator.
- 4.6 Open dielectric mold.

- 4.7 Place 50% by mass of the M/R mix into the mold. Spread the mix so that about 2.54 cm (1 in.) of material covers the bottom platen. Pack the material against the side walls to a height of 12.7 cm (5 in.) above the bottom platen with a thickness of about 1.27 cm (1/2 in.). See Sketch 4.7.

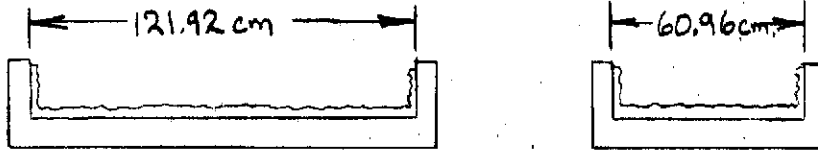

- 4.8 Position the honeycomb core into the mold and press lightly into place by hand.
- 4.9 Place the remaining 50% by mass of M/R mix onto the top of the core. Evenly distribute the mix over the core so that a consistent level is apparent.
- 4.10 Close mold to bottom against the honeycomb core and cure for 150 seconds. Set amperage control for 1.8 amps for the first 10 to 15 seconds and then reduce to 1.5 amps for the remaining cure cycle.
- 4.11 Open mold and remove panel.

Tabular work sheets are presented in Appendix B for six panels processed in the manner described above except for variations in cure cycle.

### Results of Fabrication

#### Problems Encountered

Listed below are the specific problems encountered in dielectric molding 2' X 4' panels. Each problem shall be considered separately in the analysis.

- (i) Cure on inside of panel.
- (ii) Cure on outside of panel.
- (iii) Cure on edges of panel.
- (iv) Dispersion and filling of material in core.
- (v) Lifting of material out of cells after press opens.
- (vi) Acceptable bonding of material to core.

- (vii) Core crushing.
- (viii) Cell distortion.
- (ix) Panel warpage.
- (x) Discoloration.

Problem Discussion and Analysis

- (i) Proper cure on the inside of the panel is a function of material density and RF heating time. Material which is packed tighter (higher density) will heat faster than loosely packed material. When a systematic method of loading the mold is used, a consistent density will be achieved. This density will have a corresponding optimum RF cure time which can be determined only by inspecting the inside of the panel. Brunswick's work narrowed both of these variables considerably, but further trials would be needed to optimize a production process. The sketch below defines "inside" and "outside" as referred to herein:

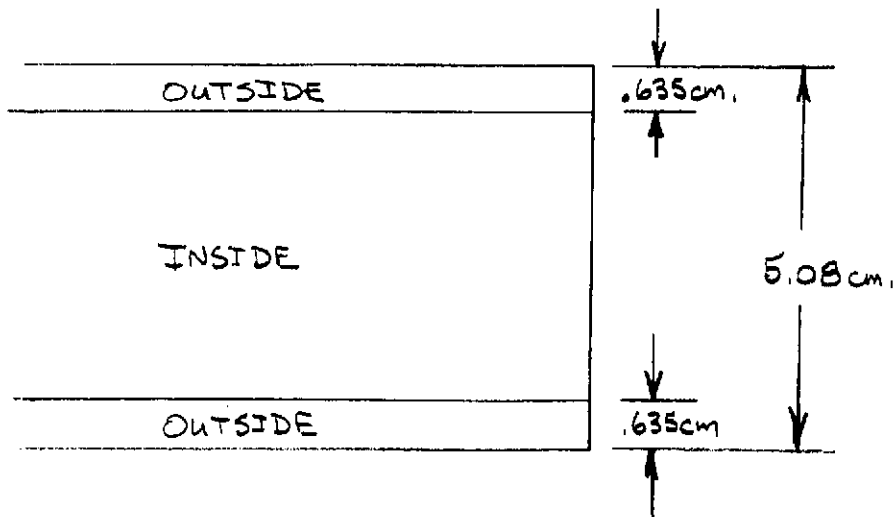

Page intentionally left blank

The six panels that were fabricated using dielectric heating were each affected to some degree by one or more of the above mentioned problems. However, no single problem occurred on each and every part. Thus, the feasibility of fabricating large scale panels using dielectric heating has been proven and only refinements of the procedures need further effort. Presses available for this size of panel are primarily found in wood bonding facilities which are normally not as clean as would be desirable for fabrication of these panels. Cleaning of the honeycomb was done prior to shipping because no cleaning capability existed at the press facility. These conditions could be very significantly improved in actual production environment and many of the problems discussed herein related to cleanliness and core bonding would be significantly reduced or eliminated.

Estimated costs for molds and equipment. - Estimated costs for molds and equipment to dielectrically cure flat panels are contained in the following table. Estimates for curved panels are not presented since no evaluation was undertaken. It is believed that curved panels can be satisfactorily cured dielectrically provided the cross-sectional thickness is constant.

Equipment	Estimated Cost
One flat panel mold, 61 cm X 122 cm (2 ft. X 4 ft.)	\$ 9,000
One 10-kW dielectric generator with an operating frequency of 16 MHz (16 megacycles) requiring a line voltage of 230-460 V.	\$15,000
Special designed press to accommodate ablative panel fabrication	\$20,000

Labor and flow time. - Estimates for labor costs are based on the experience gained in dielectric curing of six 61 cm X 122 cm X 5.08 cm (2 ft. X 4 ft. X 2 in.) flat panels. Man-hours for curved panels would require additional evaluation. Table 4 compares estimated man-hours and flow time for fabrication of a 61 cm X 122 cm X 5.08 cm (2 ft. X 4 ft. X 2 in.) flat panel. Table 5 presents a detailed breakdown of estimated man-hours and flow time for panels fabricated and cured by a steam-heated press. Table 6 provides for a detailed breakdown of estimated man-hours and flow time for dual-density panels fabricated and cured by a dielectric press. Tables 7 and 8 show the man-hours and flow time required for molding operations for a steam-heated press and dielectric press respectively. Table 9 presents a detailed breakdown of estimated man-hours and flow time for single density panels fabricated and cured by a dielectric press.

1

2

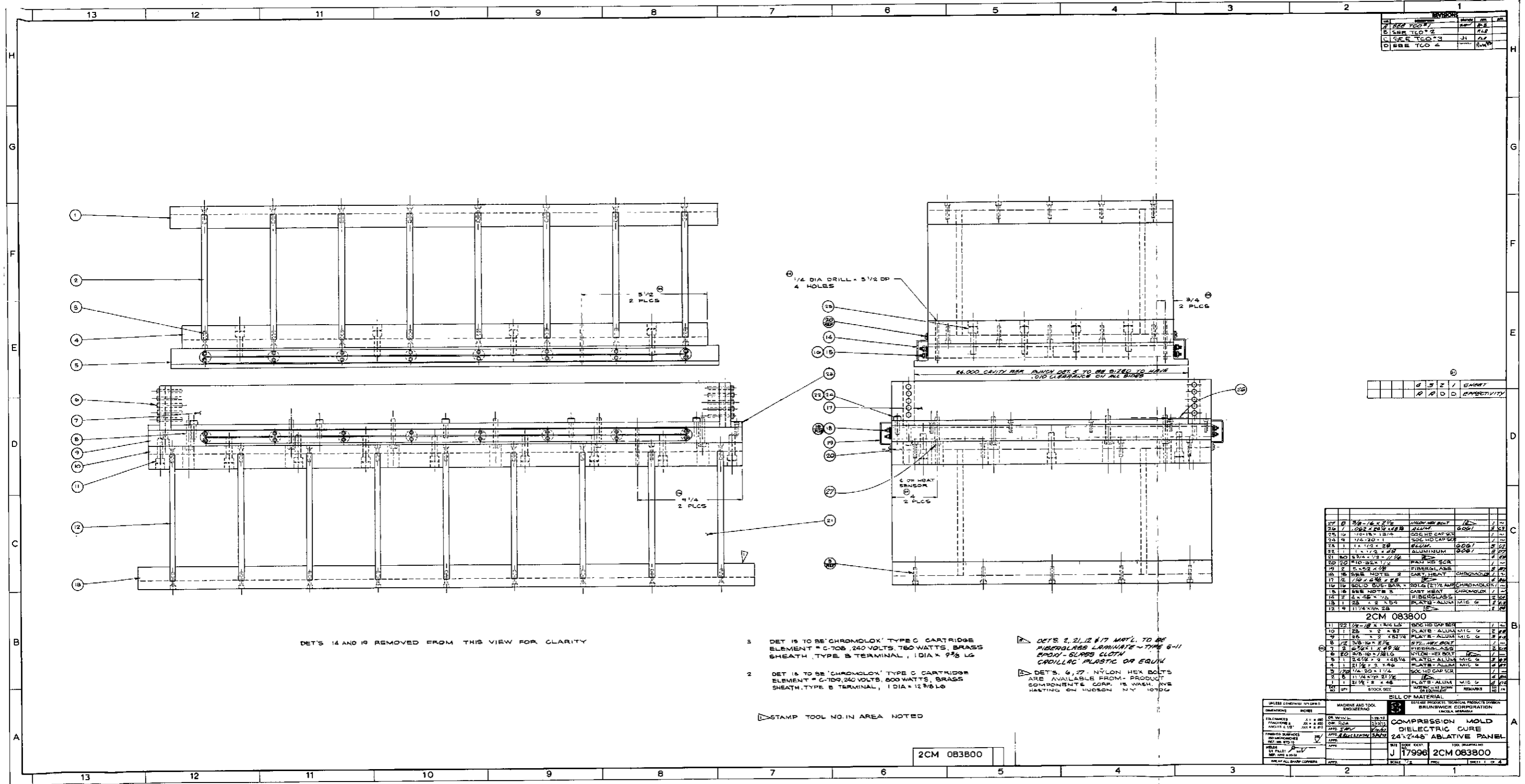

Figure 14



TABLE 4

ESTIMATED HOURS FOR FABRICATION OF A  
 LOW DENSITY ELASTOMERIC FLAT PANEL  
 61 cm X 122 cm (2 ft. X 4 ft.)

METHOD OF CURING	ESTIMATED MAN-HOURS			FLOW TIME (HOURS)		
	1 PANEL	10 PANELS	100 PANELS	1 PANEL	10 PANELS	100 PANELS
Steam-Heated Press	22.58	9.99	8.20	10.70	4.47	3.75
Dielectric Generator and Press	20.82	9.52	6.38	10.00	4.30	2.96



TABLE 6

ESTIMATED HOURS FOR FABRICATION OF A  
 LOW DENSITY ELASTOMERIC DUAL-DENSITY FLAT PANEL  
 61 cm X 122 cm (2 ft. X 4 ft.)  
 (Dielectric Cure)

OPERATION NUMBER	OPERATION DESCRIPTION	MAN-HOURS			FLOW TIME (HOURS)		
		1 PANEL	10 PANELS	100 PANELS	1 PANEL	10 PANELS	100 PANELS
1.0	Set-up Time	10.31	1.04	.10	5.50	.55	.05
1.1	Cut Honeycomb	.52	.42	.30			
1.2	Prime Honeycomb	.62	.50	.36			
1.3	Mix Ablative Material	.94	.75	.55			
1.4	Mix Insulative Mat'l	.94	.75	.55			
1.5	Measure Mix	.52	.42	.30			
1.6	Load Ablative Mix & Partial Cure	.90	.70	.50	.45	.35	.25
1.7	Load Insulative Mix & Cure	1.40	1.10	.80	.70	.55	.40
1.8	Open Mold, Remove Panel Clean & Prep for Mold	.70	.60	.50	.25	.19	.15
1.9	Press-cure Skins	1.24	.99	.71	1.30	1.09	.87
2.0	Trim Pre-cured Cloth for Localized Skin	.77	.61	.45	1.00	.90	.76
2.1	Sand Skin Bond Area	.62	.50	.36	.30	.25	.18
2.2	Apply Adhesive to Skin & Locate (6) Req'd	.52	.42	.30	.25	.21	.15
2.3	Apply Bonding Pressure	.52	.42	.30	.25	.21	.15
2.4	Weigh and Inspect	.30	.30	.30			
	Totals	20.82	9.52	6.38	10.00	4.30	2.96

TABLE 7

ESTIMATED HOURS FOR FABRICATION OF A  
 LOW DENSITY ELASTOMERIC FLAT PANEL  
 61 cm X 122 cm (2 ft. X 4 ft.)  
 -- MOLDING OPERATION ONLY --  
 STEAM HEATED PRESS

OPERATION NUMBER	OPERATION DESCRIPTION	MAN-HOURS			FLOW TIME (HOURS)		
		1 PANEL	10 PANELS	100 PANELS	1 PANEL	10 PANELS	100 PANELS
4.8	Load Mold	3.45	2.25	2.03	1.72	1.12	1.01
4.10	Cure Panel (2 hrs.)	.75	.60	.60	2.75	2.60	2.60
4.11	Cool & Open Mold	.30	.30	.30	.30	.30	.30
4.12	Clean and Reassemble Mold	1.65	1.05	.98	.83	.53	.49
	Totals	6.15	4.20	3.91	5.60	4.55	4.40

TABLE 8

ESTIMATED HOURS FOR FABRICATION OF A  
 LOW DENSITY ELASTOMERIC FLAT PANEL  
 61 cm X 122 cm (2 ft. X 4 ft.)  
 -- MOLDING OPERATION ONLY --  
 DIELECTRIC CURE

OPERATION NUMBER	OPERATION DESCRIPTION	MAN-HOURS			FLOW TIME (HOURS)		
		1 PANEL	10 PANELS	100 PANELS	1 PANEL	10 PANELS	100 PANELS
1.5	Load Insulative Mix and Cure Panel	1.40	1.10	.80	.70	.55	.40
1.6	Open Mold, Remove Panel Clean & Prep for Mold	.70	.60	.50	.35	.30	.25
	Totals	2.10	1.70	1.30	1.05	.85	.65

TABLE 9

ESTIMATED HOURS FOR FABRICATION OF A  
 LOW DENSITY ELASTOMERIC FLAT PANEL  
 61 cm X 122 cm (2 ft. X 4 ft.)  
 (Dielectric Cure)

OPERATION NUMBER	OPERATION DESCRIPTION	MAN-HOURS			FLOW TIME (HOURS)		
		1 PANEL	10 PANELS	100 PANELS	1 PANEL	10 PANELS	100 PANELS
1.0	Set-up Time	10.31	1.04	.10	5.50	.55	.05
1.1	Cut Honeycomb	.52	.42	.30			
1.2	Prime Honeycomb	.62	.50	.36			
1.3	Mix Insulative Mat'l	.94	.75	.55			
1.4	Measure Mix	.52	.42	.30			
1.5	Load Insulative Mix & Cure	1.40	1.10	.80	.70	.55	.40
1.6	Open Mold, Remove Panel Clean & Prep for Mold	.70	.60	.50	.35	.30	.25
1.7	Press-cure Skins	1.24	.99	.71	1.30	1.09	.87
1.8	Trim Precured Cloth for Localized Skin	.77	.61	.45	1.00	.90	.76
1.9	Sand Skin Bond Area	.62	.50	.36	.30	.25	.18
2.0	Apply Adhesive to Skin & Locate (6) Req'd	.52	.42	.30	.25	.21	.15
2.1	Apply Bonding Pressure	.52	.42	.30	.25	.21	.15
2.2	Weigh and Inspect	.30	.30	.30			
	Totals	18.98	8.07	5.33	9.65	4.06	2.81

Man-hour estimates have been projected for the fabrication of 181.16 m<sup>2</sup> (1950 ft<sup>2</sup>) of flat ablative panels for a one-ship, one-flight mission. The following tabulation shows the estimated savings in panel fabrication time when using a dielectric curing press versus a steam-heated press.

	<u>Man-hour Reduction</u>
Molding Operation Only . . . . .	67%
All Operations . . . . .	35%

The other significant cost benefit from the use of dielectric heating relates to the reduced number of molds necessary with this method. Dielectrically cured panels would require only 1/6 the number of molds and presses necessary for the steam heat cured panels.

Man-hours and flow times for steam-heated press operations were taken from Brunswick's previous fabrication study under NASA contract NAS 1-9945\*, and modified to represent the fabrication methods described herein. Among these modifications are the elimination of molded plugs and changes to the sequence of operations for curing skins. In the previous study, full-sized skins were cured with the steam-heated press during the panel molding operation. When panels are cured dielectrically, the skins will not be cured at the same time, nor with the same type of press. The skins will be cured into sheet stock, cut to size, and bonded as localized skins to the ablative panel in a separate operation. Localized skin surfaces are estimated to be 15.24 cm X 15.24 cm (6 in. X 6 in.).

Future studies of various resin systems may prove that the skin could be dielectrically cured at the same time the ablative panel is cured. If this technique could be developed, additional savings could be realized in material costs, man-hours, and flow time.

In considering localized skins versus a skin that covers the entire ablative panel, it should be noted that localized skins offer an approximate weight savings of 90.72 kg (200 lbs.) for only the estimated flat panel surface of one ship.

---

\*Abbott, Harry T.: Low-cost Fabrication Method for Ablative Heat Shield Panels for Space Shuttles. NASA CR-111835, 1970.

## CONCLUSIONS

The following conclusions have been established as a result of this program:

1. The 16-hour cure time specified as a requirement by Contract No. NAS 1-9945 can be reduced to 45 minutes with specific silicone elastomeric systems when using conventionally-heated aluminum compression molds.
2. Dual-density panels can be fabricated which have satisfactory ablative and insulative characteristics, and at low densities ( $194.8 \text{ kg/m}^3$  [ $12.1 \text{ lb/ft}^3$ ]) with acceptable handling properties.
3. Dielectric curing has been proven feasible on sub-scale panels, with a potential 25% man-hour reduction over conventionally cured panels.
4. Dielectric curing projects as the most economical method evaluated to date for high production rates of flat ablative panels.
5. Integral resin skins evaluated during this study are not suitable for ablative panels because of their degrading effect on ablative performance.
6. Prefabricated localized skins can be attached to ablative panels with satisfactory bond strengths as defined by the requirements of Contract No. NAS 1-9945 either with film adhesives or liquid adhesives.
7. One silicone resin used for both ablative and insulative mix (Sylgard 182, Dow Corning Corp.) was not only acceptable for mixing, molding, and ablation, but had an additional outstanding characteristic. This material could be pre-mixed with phenolic Microballoons and held in storage at room temperature for at least three months prior to use as a molding compound.
8. Based on improvements established as feasible by this contract, a potential cost reduction of 11% below the targets set by Contract No. NAS 1-9945 for equivalent size low density elastomer flat panels which have the added advantage of lighter weight ( $192.2$  versus  $240.3 \text{ kg/m}^3$  [ $12$  versus  $15 \text{ pounds/ft}^3$ ]) with improved ablative performance and handling properties.

PRECEDING PAGE BLANK NOT FILMED



## RECOMMENDATIONS

Based upon the findings of this study program, the following recommendations are presented to optimize fabrication techniques for low-cost ablative panels:

### Basic panel configuration. -

- (i) Future designs should consider localized skins at the attach points to reduce weight penalties.
- (ii) Incorporate a draft angle on all panel edges to facilitate removal from molds.
- (iii) Use dual-density panels with the ablative section at  $320 \text{ kg/m}^3$  ( $20 \text{ lbs/ft}^3$ ) followed by the insulative section at  $136 \text{ kg/m}^3$  ( $8.5 \text{ lbs/ft}^3$ ).
- (iv) Fabricate all flat panels by dielectric curing.

### Additional studies. -

- (v) Dielectric curing of skin materials during the dielectric molding cycle.
- (vi) Dielectric curing of simple and compound curved ablative panels.

Brunswick Corporation  
Technical Products Division  
Lincoln, Nebraska September 15, 1972

## APPENDIX A.

### WORK SHEET SUMMARIES

#### OF

### DIELECTRIC CURING

The work sheets presented herein include data obtained while dielectrically curing 15 ablative test panels. "Generator Load" refers to the "ablative section" for the high-density material charge and to the "insulative section" for the low-density material charge. The "type of panel" defines either the "single density" or the "dual-density" type of panel.

HEATING TEST #1

PANEL SIZE: 30.48 cm X 30.48 cm X 5.08 cm  
(12 in. X 12 in. X 2 in.)

TYPE OF PANEL: Single Density

AGE OF M/R MIX: 3 months old

MOLD TEMPERATURE:

TOP & BOTTOM 477.6° K (400° F)  
SIDE WALLS 449.8° K (350° F)

MOLD PRESSURE: 68.94 N/cm<sup>2</sup> (100 psi)

GENERATOR LOAD:	<u>Insulative Section</u>	<u>Ablative Section</u>
kV (RF)	5.0	-
Amperes (start)	.75	-
Amperes (finish)	.95	-
Duration	3 min.	-
Efficiency Factor	50%	

OBSERVATIONS:

Specimen scorched in center, not cured on sides. Material was charred so badly inside that combustion was noted 30 minutes after panel was removed from mold.

PRECEDING PAGE BLANK NOT FILMED

## HEATING TEST #2

PANEL SIZE: 30.48 cm X 30.48 cm X 5.08 cm  
(12 in. X 12 in. X 2 in.)

TYPE OF PANEL: Single Density

AGE OF M/R MIX: 3 months old

### MOLD TEMPERATURE:

TOP & BOTTOM 422.0<sup>o</sup> K (300<sup>o</sup> F)  
SIDE WALLS 310.9<sup>o</sup> K (100<sup>o</sup> F)

MOLD PRESSURE: 68.94 N/cm<sup>2</sup> (100 psi)

GENERATOR LOAD:	<u>Insulative Section</u>	<u>Ablative Section</u>
kV (RF)	5.0	-
Amperes (start)	1.5	-
Amperes (finish)	.95	-
Duration	2-1/2 min.	-
Efficiency Factor	50%	

### OBSERVATIONS:

External surface good except side walls were soft and crumbled while handling. One corner of the part was removed to examine the cure condition within the panel. No over-cure was observed. Color was uniform and the inner surface hard and firm.

### HEATING TEST #3

PANEL SIZE: 30.48 cm X 30.48 cm X 3.81 cm  
(12 in. X 12 in. X 1-1/2 in.)

TYPE OF PANEL: Single Density

AGE OF M/R MIX: 3 months old

MOLD TEMPERATURE:

TOP & BOTTOM 422.0° K (300° F)  
SIDE WALLS 310.9° K (100° F)

MOLD PRESSURE: 68.94 N/cm<sup>2</sup> (100 psi)

GENERATOR LOAD:	<u>Insulative Section</u>	<u>Ablative Section</u>
kV (RF)	4-5.0	-
Amperes (start)	1.5	-
Amperes (finish)	.85	-
Duration	2-1/2 min.	-
Efficiency Factor	50%	

#### OBSERVATIONS:

Top and bottom surface was not as smooth and firm as desirable. Material could be removed when brushing a hand across the surface. Side walls were easily crumbled and edges were soft. One corner of the part was notched to study the cross-sectional cure and found to be satisfactory. Color was even and the inner surface was hard and firm.

#### HEATING TEST #4

PANEL SIZE: 30.48 cm X 30.48 cm X 3.81 cm  
(12 in. X 12 in. X 1-1/2 in.)

TYPE OF PANEL: Single Density

AGE OF M/R MIX: 3 months old

MOLD TEMPERATURE:

TOP & BOTTOM 438.7<sup>0</sup> K (330<sup>0</sup> F)  
SIDE WALLS 322.0<sup>0</sup> K (120<sup>0</sup> F)

MOLD PRESSURE: 68.94 N/cm<sup>2</sup> (100 psi)

GENERATOR LOAD:	<u>Insulative Section</u>	<u>Ablative Section</u>
kV (RF)	4-5.0	-
Amperes (start)	1.25	-
Amperes (finish)	.85	-
Duration	2-1/2 min.	-
Efficiency Factor	50%	-

#### OBSERVATIONS:

Top and bottom surface was not smooth and as firm as desirable. Material could be removed when brushing a hand across the surface. Side walls were easily crumbled and edges were soft. One corner of the part was notched to study the cross-sectional cure and found to be satisfactory. Color was even and the inner surface was hard and firm.

### HEATING TEST #5

PANEL SIZE: 30.48 cm X 30.48 cm X 3.81 cm  
(12 in. X 12 in. X 1-1/2 in.)

TYPE OF PANEL: Dual Density

AGE OF M/R MIX: 3 months old

MOLD TEMPERATURE:

TOP & BOTTOM 449.8° K (350° F)  
SIDE WALLS 366.5° K (200° F)

MOLD PRESSURE: 68.94 N/cm<sup>2</sup> (100 psi)

GENERATOR LOAD:	<u>Insulative Section</u>	<u>Ablative Section</u>
kV (RF)	3-5.0	4.0
Amperes (start)	1.5	1.0
Amperes (finish)	.85	1.0
Duration	2-1/2 min.	1 min.
Efficiency Factor	50%	50%

#### OBSERVATIONS:

Top and bottom surfaces were firm and could be handled. The sides were soft. One corner of the part was notched to study the cross-sectional cure and found to be charred in the insulative section. The ablative section was 9.53 mm (3/8 in.) thick and a little soft inside.

HEATING TEST #6

PANEL SIZE: 30.48 cm X 30.48 cm X 5.08 cm  
(12 in. X 12 in. X 2 in.)

TYPE OF PANEL: Dual Density

AGE OF M/R MIX: 3 months old

MOLD TEMPERATURE:

TOP & BOTTOM 466.5° K (380° F)  
SIDE WALLS 405.4° K (270° F)

MOLD PRESSURE: 68.94 N/cm<sup>2</sup> (100 psi)

GENERATOR LOAD:	<u>Insulative Section</u>	<u>Ablative Section</u>
kV (RF)	2-4.0	4.0
Amperes (start)	1.25	1.0
Amperes (finish)	.7	1.0
Duration	2-1/2 min.	1 min.
Efficiency Factor	50%	50%

OBSERVATIONS:

Top and bottom exhibited a surface condition much like worm holes caused by gas developed during the cure cycle. It was felt that the primer had not air-dried sufficiently which created excessive gas. The entire structure was considered unsatisfactory.



## HEATING TEST #7

PANEL SIZE: 30.48 cm X 30.48 cm X 5.08 cm  
(12 in. X 12 in. X 2 in.)

TYPE OF PANEL: Dual Density

AGE OF M/R MIX: 3 months old

MOLD TEMPERATURE:

TOP & BOTTOM 410.9<sup>o</sup> K (280<sup>o</sup> F)  
SIDE WALLS 355.4<sup>o</sup> K (180<sup>o</sup> F)

MOLD PRESSURE: 68.94 N/cm<sup>2</sup> (100 psi)

GENERATOR LOAD:	<u>Insulative Section</u>	<u>Ablative Section</u>
kV (RF)	3-4.0	1.0
Amperes (start)	1.0	1.0
Amperes (finish)	.65	1.0
Duration	2-1/2 min.	1-1/2 min.
Efficiency Factor	50%	50%

### OBSERVATIONS:

The 6.35 mm (1/4 in.) ablative section varied in thickness up to 9.53 mm (3/8 in.) and the top surface was rough. The insulative cross-section was charred indicating over-cure. The bottom was soft and patches of material were loose enough to fall off while handling the part, indicating insufficient mold closure.

### HEATING TEST #8

PANEL SIZE: 30.48 cm X 30.48 cm X 5.08 cm  
(12 in. X 12 in. X 2 in.)

TYPE OF PANEL: Dual Density

AGE OF M/R MIX: 3 months old

MOLD TEMPERATURE:

TOP & BOTTOM 433.2° K (320° F)  
SIDE WALLS 355.4° K (180° F)

MOLD PRESSURE: 68.94 N/cm<sup>2</sup> (100 psi)

GENERATOR LOAD:	<u>Insulative Section</u>	<u>Ablative Section</u>
kV (RF)	3-4.0	4.0
Amperes (start)	1.0	1.0
Amperes (finish)	.65	1.0
Duration	2-1/2 min.	1-1/2 min.
Efficiency Factor	50%	50%

**OBSERVATIONS:**

Top and bottom surfaces were satisfactory and could be handled. Sides were soft. The ablative section was 6.35 mm (1/4 in.) thick. One corner of the part was notched to study the cross-section. The ablative section was good, but the insulative section was over-cured. Edges were soft.

## HEATING TEST #9

PANEL SIZE: 30.48 cm X 30.48 cm X 5.08 cm  
(12 in. X 12 in. X 2 in.)

TYPE OF PANEL: Single Density

AGE OF M/R MIX: 3 months old

MOLD TEMPERATURE:

TOP & BOTTOM 460.9<sup>o</sup> K (370<sup>o</sup> F)  
SIDE WALLS 366.5<sup>o</sup> K (200<sup>o</sup> F)

MOLD PRESSURE: 68.94 N/cm<sup>2</sup> (100 psi)

GENERATOR LOAD:	<u>Insulative Section</u>	<u>Ablative Section</u>
kV (RF)	2-3.0	-
Amperes (start)	1.0	-
Amperes (finish)	.65	-
Duration	2-1/2 min.	-
Efficiency Factor	50%	-

### OBSERVATIONS:

Top and bottom surfaces were hard and firm. Cross-section had a good color and was satisfactory except for edges and corners.

HEATING TEST #10

PANEL SIZE: 30.48 cm X 30.48 cm X 5.08 cm  
(12 in. X 12 in. X 2 in.)

TYPE OF PANEL: Dual Density

AGE OF M/R MIX: 3 months old

MOLD TEMPERATURE:

TOP & BOTTOM 460.9° K (370° F)  
SIDE WALLS 349.8° K (170° F)

MOLD PRESSURE: 68.94 N/cm<sup>2</sup> (100 psi)

GENERATOR LOAD:	<u>Insulative Section</u>	<u>Ablative Section</u>
kV (RF)	2-3.0	4.0
Amperes (start)	1.0	1.0
Amperes (finish)	.65	1.0
Duration	2-1/2 min.	1 min.
Efficiency Factor	50%	50%

OBSERVATIONS:

Ablative section too thick; measures 9.53 mm (3/8 in.) instead of 6.35 mm (1/4 in.) and was uneven on the top surface. Side walls were firm but edges were soft. One corner of the part was noticed to study the cross-sectional cure and found to be slightly over-cured. May have been marginal.

HEATING TEST #11

PANEL SIZE: 30.48 cm X 30.48 cm X 3.81 cm  
(12 in. X 12 in. X 1-1/2 in.)

TYPE OF PANEL: Dual Density

AGE OF M/R MIX: 1 day old

MOLD TEMPERATURE:

TOP & BOTTOM 460.9<sup>0</sup> K (370<sup>0</sup> F)  
SIDE WALLS 372.0<sup>0</sup> K (210<sup>0</sup> F)

MOLD PRESSURE: 68.94 N/cm<sup>2</sup> (100 psi)

GENERATOR LOAD:	<u>Insulative Section</u>	<u>Ablative Section</u>
kV (RF)	2-3.0	4.0
Amperes (start)	.9	1.0
Amperes (finish)	.55	1.0
Duration	2-1/2 min.	1-1/2 min.
Efficiency Factor	50%	50%

OBSERVATIONS:

External surface good except edges were soft. The part was notched to study cross-sectional cure and was considered satisfactory.

HEATING TEST #12

PANEL SIZE: 30.48 cm X 30.48 cm X 3.81 cm  
(12 in. X 12 in. X 1-1/2 in.)

TYPE OF PANEL: Dual Density

AGE OF M/R MIX: 1 day old

MOLD TEMPERATURE:

TOP & BOTTOM 460.9° K (370° F)  
SIDE WALLS 377.6° K (220° F)

MOLD PRESSURE: 68.94 N/cm<sup>2</sup> (100 psi)

GENERATOR LOAD:	<u>Insulative Section</u>	<u>Ablative Section</u>
kV (RF)	2-3.0	4.0
Amperes (start)	.9	1.0
Amperes (finish)	.55	1.0
Duration	2-1/2 min.	1-1/2 min.
Efficiency Factor	50%	50%

OBSERVATIONS:

External surface good except edges were soft. The part was notched to study cross-sectional cure and was considered satisfactory. It was determined that the next part should have additional material brought to the side walls to obtain improved compression at the edges and side walls of the cured panel.

The generator load and time was the same as Heating Test #11 as were the remaining Heating Tests #12, 13, 14, and 15.

HEATING TEST #13

PANEL SIZE: 30.48 cm X 30.48 cm X 3.81 cm  
(12 in. X 12 in. X 1-1/2 in.)

TYPE OF PANEL: Single Density

AGE OF M/R MIX: 1 day old

MOLD TEMPERATURE:

TOP & BOTTOM 460.9<sup>o</sup> K (370<sup>o</sup> F)  
SIDE WALLS 377.6<sup>o</sup> K (220<sup>o</sup> F)

MOLD PRESSURE: 68.94 N/cm<sup>2</sup> (100 psi)

GENERATOR LOAD:	<u>Insulative Section</u>	<u>Ablative Section</u>
kV (RF)	2-3.0	-
Amperes (start)	.9	-
Amperes (finish)	.55	-
Duration	2-1/2 min.	-
Efficiency Factor	50%	

OBSERVATIONS:

External appearance good. Part was sent to NASA for evaluation.

HEATING TEST #14

PANEL SIZE: 30.48 cm X 30.48 cm X 3.81 cm  
(12 in. X 12 in. X 1-1/2 in.)

TYPE OF PANEL: Single Density

AGE OF M/R MIX: 3 months old

MOLD TEMPERATURE:

TOP & BOTTOM 460.9<sup>0</sup> K (370<sup>0</sup> F)  
SIDE WALLS 377.6<sup>0</sup> K (220<sup>0</sup> F)

MOLD PRESSURE: 68.94 N/cm<sup>2</sup> (100 psi)

GENERATOR LOAD:	<u>Insulative Section</u>	<u>Ablative Section</u>
kV (RF)	2-3.0	-
Amperes (start)	-	-
Amperes (finish)	.55	-
Duration	2-1/2 min.	-
Efficiency Factor	50%	-

OBSERVATIONS:

External appearance good. Part was sent to NASA for evaluation.



### HEATING TEST #15

PANEL SIZE: 30.48 cm X 30.48 cm X 5.08 cm  
(12 in. X 12 in. X 2 in.)

TYPE OF PANEL: Dual Density

AGE OF M/R MIX: 3 months old

MOLD TEMPERATURE:

TOP & BOTTOM 460.9<sup>o</sup> K (370<sup>o</sup> F)  
SIDE WALLS 377.6<sup>o</sup> K (220<sup>o</sup> F)

MOLD PRESSURE: 68.94 N/cm<sup>2</sup> (100 psi)

GENERATOR LOAD:	<u>Insulative Section</u>	<u>Ablative Section</u>
kV (RF)	2-3.0	4.0
Amperes (start)	.9	1.0
Amperes (finish)	.55	1.0
Duration	2-1/2 min.	2-1/2 min.
Efficiency Factor	50%	50%

OBSERVATIONS:

External appearance good. Part sent to NASA for evaluation.

## APPENDIX B

### WORK SHEET SUMMARIES OF DIELECTRIC CURING

The work sheets presented herein include data obtained while dielectrically curing 6 ablative test panels (61 cm X 122 cm X 5.08 cm). "Generator Load" refers to the load applied to the material within the mold. In all cases the "type of panel" fabricated was "single density".

PRECEDING PAGE BLANK NOT FILMED

PANEL #1

PANEL SIZE: 60.96 cm X 121.92 cm X 5.08 cm  
(24 in. X 48 in. X 2 in.)

TYPE OF PANEL: Single Density

AGE OF M/R MIX: 3 months

MOLD TEMPERATURE:

TOP & BOTTOM PLATENS 377.59° K (220° F)

SIDE WALLS 310.92° K (100° F)

MOLD PRESSURE: 68.94 N/cm<sup>2</sup> (100 psi)

GENERATOR LOAD:

Starting Amperage (for 10-15 seconds)	2.5 amps
Nominal	1.8 amps
Peaked at 1-1/2 minutes	3.5-4.0 amps
Finish	1.8 amps
Total RF Time	2-1/2 minutes
Dwell Time	15 seconds

RESULTS:

1. Inside overcured slightly.
2. Outside surfaces top and bottom not cured completely.
3. Edges uncured.

PRECEDING PAGE BLANK NOT FILMED

COMMENTS:

Numerous complications in this fabrication caused the overall poor appearance and integrity.

1. The honeycomb core was coated too heavily with phenolic primer. This primer is susceptible to moisture absorption, thus when it was heated with the RF it gave off steam, disrupting the bonding of the Microballoons and resin to the core.
2. The upper and lower platens were not at the proper temperature to effectively cure the panel surface. Equipment failure was the reason for the low temperatures.
3. The side walls being made of glass do not heat up like the aluminum platens. They must be heated to approximately 220° F for a proper cure around the edges.
4. Packing the material properly is a difficult job. Extra material must be packed around the edge of the panel in order to increase the density and thus increase heating from the RF. It would be possible to cure the edges with RF only (no high temperature on side walls) if the density at these areas could be controlled better. A higher density material heats faster with RF than a lower density material. Extreme high densities cause too high heating plus difficulty in closing the mold.

PANEL #2

PANEL SIZE: 60.96 cm X 121.92 cm X 5.08 cm  
(24 in. X 48 in. X 2 in.)

TYPE OF PANEL: Single Density

AGE OF M/R MIX: 3 months

MOLD TEMPERATURES:

Top & Bottom Platens 435.93° K (325° F)  
Side Walls 338.71° K (150° F)

MOLD PRESSURE: 68.94 N/cm<sup>2</sup> (100 psi)

GENERATOR LOAD:

Starting Amperage (for 10-15 seconds)	2.5 amps
Nominal	1.8 amps
Reduced below nominal at 1-3/4 minutes	1.4 amps
Finish	1.4 amps
Total RF Time	2-1/2 minutes
Dwell Time	2 minutes

RESULT:

1. Inside overcured slightly. Marginal.
2. Outside surfaces top and bottom cured completely.
3. Edges cured completely except for a few localized areas that didn't cure.

COMMENTS:

This panel proved that the problems with No. 1 were caused by the platen temperatures not being high enough. When the top and bottom surfaces are heated high enough, there is no problem with the material curing on the outside. The edges need extra heavy density to cure throughout the two-inch thickness. Even with a hot upper and lower platen, the outside edges will not cure unless tightly compacted.

This panel also used honeycomb which, after it had been primed with phenolic resin, was allowed to dry on paper towels for one hour. Visual inspection of the thickness of the primer coating on the cells revealed that there was no appreciable accumulation. The core was tacky, but not wet. Much less steam vented from the mold on this panel than on panel No. 1. The lack of moisture and consequent no generation of steam were critical factors which helped affect the curing of the material in a favorable manner.

PANEL #3

PANEL SIZE: 60.96 cm X 121.92 cm X 5.08 cm  
(24 in. X 48 in. X 2 in.)

TYPE OF PANEL: Single Density

AGE OF M/R MIX: 3 months

MOLD TEMPERATURES:

Top & Bottom Platens 422.04° K (300° F)  
Side Walls 338.71° K (150° F)

MOLD PRESSURE: 68.94 N/cm<sup>2</sup> (100 psi)

GENERATOR LOAD:

Starting Amperage 1.8 amps  
Nominal 1.8 amps  
Finish 1.8 amps  
Total RF Time 2 minutes  
Dwell Time 1 minute

RESULTS:

1. Inside overcured.
2. Outside top and bottom cured completely. Core crushed because of uneven platen closure.
3. Edges cured very hard.

COMMENTS:

This is the first panel in which extreme attention was directed towards the packing of material around the outside edges of the core. Both packing or filling sequences placed additional material next to the walls for a thickness of probably 1/2" to 3/4". Closure of the dye into the mold was hampered because of unlevelness of the bottom platen. The press was opened and closed probably six times before the thick side would compress to the desired two inches. But while accomplishing this, the opposite side was crushed too thin. The panel was slightly overcured in the center region.

PANEL #4

PANEL SIZE: 60.96 cm X 121.92 cm X 5.08 cm  
(24 in. X 48 in. X 2 in.)

TYPE OF PANEL: Single Density

AGE OF M/R MIX: 3 months

MOLD TEMPERATURE:

Top & Bottom Platens 460.93° K (370° F)  
Side Walls 338.71° K (150° F)

MOLD PRESSURE: 68.94 N/cm<sup>2</sup> (100 psi)

GENERATOR LOAD:

Starting Amperage (for 10-15 seconds)	2.5 amps
Nominal	1.8 amps
Reduced below nominal at 1-1/2 minutes	1.5 amps
Finish	1.5 amps
Total RF Time	2-1/4 minutes
Dwell Time	1-3/4 minutes

RESULTS:

1. Inside not inspected.
2. Outside top and bottom surfaces cured completely. Lower surface may be overcured slightly.
3. Edges cured good. Some soft spots.
4. Part was sent to NASA for evaluation.



COMMENTS:

This was a good panel except for the following:

1. Slight overcure on bottom surface. This is caused by material being in contact with hot platen for perhaps 5 minutes longer than material on top. Need a lower temperature bottom platen, about 325° F.
2. One corner had cavities caused by insufficient material packing.
3. Some points around edges are soft, not fully cured. This is caused by too less of density at the edges to heat up to curing temperature.
4. Front bottom edge broke away when front wall was removed from panel.

PANEL #5

PANEL SIZE: 60.96 cm X 121.92 cm X 5.08 cm  
(24 in. X 48 in. X 2 in.)

TYPE OF PANEL: Single Density

AGE OF M/R MIX: 3 months

MOLD TEMPERATURE:

Top & Bottom Platens 452.59° K (355° F)  
Side Walls 338.71° K (150° F)

MOLD PRESSURE: 68.94 N/cm<sup>2</sup>

GENERATOR LOAD:

Starting Amperage (for 30 seconds)	1.8 amps
Nominal	1.5 amps
Finish	1.5 amps
Total RF Time	2-1/2 minutes
Dwell Time	10-15 seconds

RESULTS:

1. Inside not inspected.
2. Outside top and bottom surfaces completely cured. Porous surfaces present.
3. Edges cured good.

COMMENTS:

Another good panel. Both top and bottom surfaces of the panel are cured hard. There is some evidence of trouble in packing the bottom surface consistently in each cell. That is, there are some areas on the bottom surface that do not have the same density as on the top. These areas are more porous and visually rough.

The dwell time is nearing that used in the smaller (12" X 12" X 2") sample tests, namely zero. The panels appear to be warping while in the mold. This may be caused by the thin aluminum sheet underneath which is warping, or else just by the material expanding or contracting on opposite sides. The panel raises slightly in the middle, probably 1/2" to 3/4".

PANEL #6

PANEL SIZE: 60.96 cm X 121.92 cm X 5.08 cm  
(24 in. X 48 in. X 2 in.)

TYPE OF PANEL: Single Density

AGE OF M/R MIX: 3 months

MOLD TEMPERATURE:

Top & Bottom Platens 435.93° K (325° F)  
Side Walls 338.71° K (150° F)

MOLD PRESSURE: 68.94 N/cm<sup>2</sup> (100 psi)

GENERATOR LOAD:

Starting Amperage (for 30 seconds)	1.8 amps
Nominal	1.5 amps
Finish	1.5 amps
Total RF Time	2-1/2 minutes
Dwell Time	10 seconds

RESULTS:

1. Inside not inspected.
2. Outside surfaces top and bottom are completely cured. Discoloration of material is noted.
3. Edges are cured at some locations and uncured at others.

COMMENTS:

The top and bottom surface finish of this panel is excellent.  
The sides are mostly cured good except for a few isolated soft spots.

## ABSTRACT

This report describes the fabrication, testing, and evaluation of materials and techniques employed in the fabrication of ablative heat shield panels. Results of this effort show projected reductions in labor man-hours for dielectric curing of panels when compared to panels molded in a steam-heated press. In addition, panels were fabricated with more than one density within the cross-section. These dual-density panels show significant weight and cost reduction potentials.