

**NASA TECHNICAL  
MEMORANDUM**



**NASA TM X-2931**

**NASA TM X-2931**

**EFFECT OF INCREASED FUEL TEMPERATURE  
ON EMISSIONS OF OXIDES OF NITROGEN  
FROM A GAS TURBINE COMBUSTOR  
BURNING ASTM JET-A FUEL**

*by Nicholas R. Marchionna*

*Lewis Research Center*

*Cleveland, Ohio 44135*

**NATIONAL AERONAUTICS AND SPACE ADMINISTRATION • WASHINGTON, D. C. • JANUARY 1974**

1. Report No. NASA TM X-2931	2. Government Accession No.	3. Recipient's Catalog No.	
4. Title and Subtitle EFFECT OF INCREASED FUEL TEMPERATURE ON EMISSIONS OF OXIDES OF NITROGEN FROM A GAS TURBINE COMBUSTOR BURNING ASTM JET-A FUEL		5. Report Date January 1974	
		6. Performing Organization Code	
7. Author(s) Nicholas R. Marchionna		8. Performing Organization Report No. E-7634	
		10. Work Unit No. 501-24	
9. Performing Organization Name and Address Lewis Research Center National Aeronautics and Space Administration Cleveland, Ohio 44135		11. Contract or Grant No.	
		13. Type of Report and Period Covered Technical Memorandum	
12. Sponsoring Agency Name and Address National Aeronautics and Space Administration Washington, D.C. 20546		14. Sponsoring Agency Code	
		15. Supplementary Notes	
16. Abstract An annular gas turbine combustor was tested with heated ASTM Jet-A fuel to determine the effect of increased fuel temperature on the formation of oxides of nitrogen (NO <sub>x</sub> ). Fuel temperature ranged from ambient to 700 K (800° F). The NO <sub>x</sub> emission index increased at a rate of 6 percent per 100 K (180° F) increase in fuel temperature.			
17. Key Words (Suggested by Author(s)) Air pollution; Combustion; Oxides of nitrogen; Heated fuel; Combustors; Jet engines		18. Distribution Statement Unclassified - unlimited	
19. Security Classif. (of this report) Unclassified	20. Security Classif. (of this page) Unclassified	21. No. of Pages 17	22. Price* Domestic, \$2.75 Foreign, \$5.25

EFFECT OF INCREASED FUEL TEMPERATURE ON EMISSIONS  
OF OXIDES OF NITROGEN FROM A GAS TURBINE  
COMBUSTOR BURNING ASTM JET-A FUEL

by Nicholas R. Marchionna

Lewis Research Center

SUMMARY

An annular gas turbine combustor was tested with heated ASTM Jet A fuel to determine the effect of increased fuel temperature on the formation of oxides of nitrogen ( $\text{NO}_x$ ). Fuel temperature ranged from ambient to 700 K (800° F). Combustor pressure was 4 atmospheres, inlet-air temperature was 838 K (1050° F), and reference Mach number was 0.075. The  $\text{NO}_x$  emission index increased at a rate of 6 percent per 100 K (180° F) increase in fuel temperature. The result agrees with the results obtained in similar tests with heated natural-gas fuel. The result is also in agreement with the result expected from a simplified combustion model which relates the increase in the formation rate of nitric oxide to the increase in stoichiometric flame temperature.

INTRODUCTION

This report presents the results of combustor tests which were conducted to determine the effect of increasing fuel temperature on the formation of oxides of nitrogen ( $\text{NO}_x$ ) from liquid ASTM Jet-A fuel.

Proposed use of the aircraft fuel as a heat sink for supersonic flight would increase the fuel temperature. Since the formation rate of nitric oxide (NO) is strongly dependent on flame temperature, the increased fuel temperature may raise the flame temperature enough to significantly increase NO emissions. On the other hand, the flammability limits of the fuel increase with increasing fuel temperature, which may allow the fuel to be burned at off-stoichiometric fuel-air ratios, where the rate of formation of NO is lower. Reference 1 reports the effects of fuel temperature for natural-gas fuel. It was found that the  $\text{NO}_x$  emission index increased by approximately 4 percent per 100 K

(180° F) increase in fuel temperature at combustor temperatures simulating that of supersonic cruise.

The investigation reported herein was conducted to determine how the inlet temperature of ASTM Jet A-fuel affects the NO<sub>x</sub> emission index and to compare these results with those of reference 1 for natural-gas fuel. The investigation was conducted with the same full annular ram induction combustor used in reference 1. Fuel temperatures were varied from ambient to 700 K (800° F) at combustor inlet conditions simulating supersonic cruise pressure and temperature of 4 atmospheres and 838 K (1050° F), respectively.

The units for physical quantities in this report are given in both the International System of Units (SI) and the U.S. customary system. However, measurements during the investigation were made in the U.S. customary system.

## APPARATUS AND PROCEDURE

### Facility

Testing was conducted in a closed-duct test facility of the Engine Components Research Laboratory of the Lewis Research Center. A schematic of this facility is shown in figure 1. A detailed description of the facility and instrumentation are contained in reference 2. All fluid flow rates and pressures are controlled remotely.

### Test Combustor

The combustor tested was designed using the ram-induction approach and is described in reference 3. With this approach, the compressor discharge air is diffused less than it is in conventional combustors. The relatively high-velocity air is captured by scoops in the combustor liner and turned into the combustion and mixing zones. Vanes are used in the scoops to reduce pressure loss caused by the high-velocity turns. The high velocity and the steep angle of the entering air jets promote rapid mixing of both the fuel and air in the combustion zone and the burned gases and air in the dilution zone. The potential result of rapid mixing is a shorter combustor or, alternatively, a better exit temperature profile in the same length.

A cross section of the combustor is shown in figure 2. The outer diameter is approximately 1.06 meters (42 in.), and the length from compressor exit to turbine inlet is approximately 0.76 meter (30 in.). A snout on the combustor divides the diffuser into three concentric annular passages. The central passage conducts air to the combustor

headplates and the inner and outer passages supply air to the combustor liners. There are five rows of scoops on each of the inner and outer liners to turn the air into the combustion and dilution zones.

The snout and the combustor liners are shown in figure 3. Figure 3(a) is a view looking upstream into the combustor liner. The scoops in the inner and outer liners can be seen, as well as the openings in the headplate for the fuel nozzles and swirlers. Figure 3(b) is a view of the snout and the upstream end of the combustor liner. The V-shaped cutouts in the snout fit around struts in the diffuser. The circular holes through the snout walls are for the fuel nozzle struts. Figure 3(c) gives a closer view of the liner and headplate, showing the liquid fuel nozzles and swirlers in place. There are a total of 24 fuel nozzles in the combustor.

### Exhaust-Gas Sampling

Concentrations of nitric oxide, total oxides of nitrogen, carbon monoxide, unburned hydrocarbons, and carbon dioxide were obtained with an on-line system. The samples were drawn at the combustor exit from three circumferential locations ( $120^\circ$  apart) and at five radial positions, through water-cooled stainless-steel probes. The exit instrumentation plane is shown in figure 2. The sample probe is pictured in figure 4.

Gas sampling system. - The samples collected by the three sampling probes were common manifolded to one sampling line. Approximately 18 meters (60 ft) of 0.95-centimeter (3/8-in.) stainless-steel line was used to transport the sample to the analytical instruments. To prevent condensation of water and to minimize adsorption-desorption effects of hydrocarbon compounds, the line was electrically heated to 420 K ( $310^\circ$  F). Sampling line pressure was maintained at 1.7 atmospheres absolute to supply sufficient pressure to operate the instruments. Sufficient sample was vented at the instruments to provide a line residence time of about 2 seconds.

The exhaust-gas analysis system shown in figure 5 is a packaged unit consisting of four commercially available instruments along with associated peripheral equipment necessary for sample conditioning and instrument calibration. In addition to visual readout, electrical inputs were provided to an IBM 360 computer for on-line analysis and evaluation of the data.

The hydrocarbon content of the exhaust gas was determined by a Beckman Instruments Model 402 Hydrocarbon Analyzer. This instrument is of the flame ionization detector type.

The concentration of the oxides of nitrogen was determined by a Thermo Electron Corporation Model 10A Chemiluminescent Analyzer. The instrument includes a thermal converter to reduce  $\text{NO}_2$  to NO and was operated at 973 K ( $1290^\circ$  F).

Both carbon monoxide and carbon dioxide analyzers are of the nondispersive infrared (NDIR)-type (Beckman Instruments Model 315B). The CO analyzer has four ranges: 0 to 100 ppm, 0 to 1000 ppm, 0 to 1 percent, and 0 to 10 percent. This range of sensitivity is accomplished by using stacked cells of 0.65-centimeter (0.25-in.) and 34-centimeter (13.5-in.) length. The CO<sub>2</sub> analyzer has two ranges, 0 to 5 percent and 0 to 10 percent, with a sample cell length of 0.32 centimeter (0.125 in.).

Analytical procedure. - All analyzers were checked for zero and span prior to the test. Solenoid switching within the console allows rapid selection of zero, span, or sample modes. Therefore, it was possible to perform frequent checks to ensure calibration accuracy without disrupting testing.

Where appropriate, the measured quantities were corrected for water vapor removed. The correction included inlet-air humidity and water vapor from combustion. The equations used were obtained from reference 4.

The emission levels of all the constituents were converted to an emission index (EI) parameter. The EI may be computed from the measured quantities as proposed in reference 4 or by an alternate procedure which uses the metered fuel-air ratio when this is accurately known. With the latter scheme the EI for any constituent X is given by

$$EI_X = \frac{m_X}{m_e} \frac{1+f}{f} [X] 10^{-3} \quad (1)$$

where

$EI_X$  emission index in grams of X per kg of fuel burned

$m_X$  molecular weight of X

$m_e$  average molecular weight of exhaust gas

f metered fuel-air ratio

X measured concentration of X in ppm

Both procedures yield identical results when the sample validity is good.

### Fuel System

The fuel system shown schematically in figure 1 was limited in fuel heating capability. The fuel heater was designed to heat 0.45 kg/sec (1 lb/sec) of natural-gas fuel to approximately 800 K (980° F) for the work done in reference 1. The fuel heater had to be converted for use with Jet-A fuel because it requires more enthalpy than natural

gas to arrive at the same temperature. Table I lists the enthalpy properties of Jet-A (ref. 5) and natural-gas fuels (ref. 6).

A set of available fuel nozzles was chosen which would maintain a high back pressure in the fuel heater and fuel manifold system. The high back pressure ( $>18$  atm) was required to heat the fuel in one phase and thus avoid fractionation and coking in the fuel heater. Also, once the fuel is heated, the pressure must be maintained in the fuel supply manifold to the combustor to avoid two-phase flow. Such flow would produce an uneven fuel flow distribution to the combustor.

### Test Condition

The combustor was operated at a simulated supersonic cruise condition of 4 atmospheres pressure, an inlet-air temperature of 838 K ( $1050^{\circ}$  F), and a combustor reference Mach number of approximately 0.075. The desired combustor exhaust-gas temperature was 1478 K ( $2200^{\circ}$  F). Some data were taken at lower fuel flows (lower exhaust-gas temperatures) to obtain higher fuel temperatures. This action was caused by the limitations of the fuel heating system previously described and the fact that the lower heating value per unit weight of Jet-A fuel compared to natural gas requires more fuel flow to obtain the same combustor exhaust-gas temperature.

## RESULTS AND DISCUSSION

Data taken during the test program are presented in table II. The  $\text{NO}_x$  emissions data were adjusted to zero inlet-air humidity by multiplying the measured values by the empirical factor  $e^{19H}$ , where H is the absolute humidity (g of water/g of dry air), reference 7. To reduce the scatter in the data, the  $\text{NO}_x$  emissions data were also adjusted to the nominal reference Mach number by assuming that  $\text{NO}_x$  varies inversely with Mach number, reference 7.

### Effect of Fuel Temperature on Oxides of Nitrogen

The  $\text{NO}_x$  emission index increased with increasing fuel temperature, as shown in figure 6. The increase in  $\text{NO}_x$  with fuel temperature is attributed to increased flame temperature in the primary combustion zone, which is caused by the increased enthalpy of the fuel. Increasing flame temperature increases the rate of formation of nitric oxide (NO) with time, reference 7;

$$[\dot{\text{NO}}] = 9.5 k_2 \left\{ \exp \left( \frac{-75.5 \text{ kcal/g-mole}}{RT_f} \right) \times [\text{O}] \times [\text{N}_2] \right\} \quad (2)$$

where

$[\dot{\text{NO}}]$  rate of formation of NO,  $d[\text{NO}]/dt$

$k_2$   $(13 \pm 4) \times 10^{12} \text{ cm}^3 \text{ mole}^{-1} \text{ sec}^{-1}$

$R$   $1.987 \text{ cal}/(\text{g-mole})(\text{K})$

$[\text{NO}]$  concentration of NO

$[\text{O}]$  concentration of O

$[\text{N}_2]$  concentration of  $\text{N}_2$

$T_f$  flame temperature, K

If the concentrations of  $\text{N}_2$  and O remain constant, the rate equation (2) implies an exponential increase in NO formation with increasing flame temperature.

The rate of increase in  $\text{NO}_x$  which might be expected from an increase in fuel temperature can be calculated based on a simplified combustion model. The model specifies that all the  $\text{NO}_x$  is formed in a primary combustion zone where the fuel-air ratio is stoichiometric and that all the additional enthalpy of the fuel raises only the primary-zone flame temperature, affecting the rate of formation of NO (eq. (2)). The change in flame temperature may be calculated from the change in enthalpy of the heated fuel:

$$\Delta T_{\text{flame}} = \frac{\Delta H_{\text{fuel}}}{C_p} \left( \frac{f/a}{1 + f/a} \right) \quad (3)$$

where

$\Delta T_{\text{flame}}$  change in flame temperature

$\Delta H$  change in enthalpy of the fuel due to heating

$C_p$  specific heat at constant pressure of the combustion gases at a stoichiometric fuel-air ratio (ref. 8) of about 0.6

$f/a$  stoichiometric fuel-air ratio

By using equations (2) and (3), the increase in formation rate of NO concentration may be calculated:



$$\frac{[\dot{\text{NO}}]}{[\dot{\text{NO}}]_0} = \frac{\exp\left[\frac{-75.5}{R(T_0 + \Delta T)}\right]}{\exp\left[\frac{-75.5}{RT_0}\right]} \quad (4)$$

where  $[\dot{\text{NO}}]_0$  corresponds to the rate of formation of  $[\text{NO}]$  at ambient fuel temperature for a stoichiometric flame temperature  $T_0$ .

This calculation was carried out for the inlet-air temperature tested. Figure 7 shows the theoretical result and the data normalized to the value with ambient fuel temperature, 300 K (80° F). The data agree well with the model. The  $\text{NO}_x$  emission index increased approximately 6 percent per 100 K (180° F) increase in fuel temperature.

### Comparison with Natural Gas

The rate of increase in  $\text{NO}_x$  fuel temperature is similar to the results obtained with natural-gas fuel in reference 1. Figure 8 shows a comparison of the results obtained with the two fuels. The curves are normalized to the respective  $\text{NO}_x$  emission values at ambient fuel temperature (300 K (80° F)). The increase in  $\text{NO}_x$  with Jet-A fuel is slightly higher than the increase in  $\text{NO}_x$  with natural-gas fuel. This would be expected from the increased enthalpy available with Jet-A at the same temperature. In a practical aircraft application, however, the increased heat-sink capability of Jet-A could mean lower fuel temperatures delivered to the combustor for a given heat addition to the fuel.

### Effect of Overall Fuel-Air Ratio on Oxides of Nitrogen

Figure 9 shows that there was essentially no effect of overall fuel-air ratio on  $\text{NO}_x$  emission index with the fuel at ambient temperature at this test condition. Unpublished data of  $\text{NO}_x$  emissions at other test conditions also indicates that, for this combustor, fuel-air ratio has very little effect on  $\text{NO}_x$  emission index.

### Sample Validity

A calculation of the gas sample fuel-air ratio was made for each data point. The ratio of the gas sample fuel-air ratio to the metered fuel-air ratio (fuel-air-ratio ratio) is presented in table II. The maximum data scatter is  $\pm 5$  percent about a mean of 1.10.

The fact that the mean value is 10 percent high is probably symptomatic of the location of the sampling probes and does not invalidate the trends in the data.

### Combustion Efficiency

Combustion efficiency was primarily determined by exhaust-gas sampling and was over 99.96 percent at all test conditions (see table II). A check on the combustion efficiency could be made by measuring the average exhaust-gas temperature with a rotating thermocouple rake. These measurements were made at only limited data points. The enthalpy addition due to heating the fuel was taken into account in the efficiency calculation as determined by exhaust-gas temperature. The thermocouple data supported the results obtained with gas sampling.

### Nitric Oxide Content in Oxides of Nitrogen

Nitric oxide (NO) made up approximately 96 percent of the  $\text{NO}_x$  emission index at the nominal test condition of 4 atmospheres pressure. Previous tests with this combustor at 6 atmospheres pressure and the same inlet and temperature indicated that the NO made up approximately 91 percent of the  $\text{NO}_x$  emission index at those conditions.

### SUMMARY OF RESULTS

A test was conducted to determine the effect of increased fuel temperature on the formation of oxides of nitrogen ( $\text{NO}_x$ ). An annular gas turbine combustor was tested with heated ASTM Jet-A fuel at fuel temperatures from ambient to 700 K (800° F). Combustor inlet-air conditions simulated conditions at supersonic cruise. Combustor pressure was 4 atmospheres, inlet-air temperature was 838 K (1050° F), and reference Mach number was 0.075. The  $\text{NO}_x$  emission index increased at a rate of 6 percent per 100 K (180° F) increase in fuel temperature. The result agrees with the results obtained in similar tests run on the same combustor with heated natural gas. The result is also in agreement with the result expected from a simplified combustion model which relates

the increase in the formation rate of nitric oxide to the increase in stoichiometric flame temperature.

Lewis Research Center,  
National Aeronautics and Space Administration,  
Cleveland, Ohio, October 1, 1973,  
501-24.

#### REFERENCES

1. Marchionna, Nicholas R.: Effect of Increased Fuel Temperature on Emissions of Oxides of Nitrogen From a Gas Turbine Combustor Burning Natural Gas. NASA TM X-2930, 1973.
2. Adam, Paul W.; and Norris, James W.: Advanced Jet Engine Combustor Test Facility. NASA TN D-6030, 1970.
3. Rusnak, J. P.; and Shadowen, J. H.: Development of an Advanced Annular Combustor. Rep. PWA-FR-2832, Pratt & Whitney Aircraft (NASA CR-72453), May 30, 1969.
4. Anon.: Procedure for the Continuous Sampling and Measurement of Gaseous Emissions from Aircraft Turbine Engines. Aerospace Recommended Practice 1256, SAE, Oct. 1, 1971.
5. Faith, L. E.; Ackerman, G. H.; and Henderson, H. T.: Heat Sink Capability of a Jet A Fuel: Heat Transfer and Coking Studies. Rep. S-14115, Shell Development Co. (NASA CR-72951), July 1971.
6. Johnson, Robert C.: Tables of Critical-Flow Functions and Thermodynamic Properties for Methane and Computational Procedures for both Methane and Natural Gas. NASA SP-3074, 1972.
7. Marchionna, Nicholas R.; Diehl, Larry A.; Trout, Arthur M.: Effect of Inlet Air Humidity, Temperature, Pressure, and Reference Mach Number on the Formation of Oxides of Nitrogen in a Gas Turbine Combustor. NASA TN D-7396, 1973.
8. Poferl, David J.; Svehla, Roger A.; and Lewandowski, Kenneth: Thermodynamic and Transport Properties of Air and the Combustion Products of Natural Gas and of ASTM-A-1 Fuel with Air. NASA TN D-5452, 1969.

TABLE I. - COMPARISON OF ENTHALPY PROPERTIES OF JET A AND NATURAL GAS

Fuel	Enthalpy at two fuel temperatures, J/g of fuel		Enthalpy difference $\Delta T = 500$ K (900° F), J/g	Lower heating valve		Stoichiometric fuel-air ratio	Critical point		
	273 K (32° F)	773 K (930° F)		J/g	Btu/lb		Temperature, K	Temperature, °F	Pressure, atm
Jet-A	0	1590	1590	$4.3 \times 10^4$	18 600	0.067	656	720	18.0
Natural gas	571	2066	1495	4.0	21 500	.0582	111	-116	45.7

TABLE II. - EXPERIMENTAL DATA

Airflow, kg/sec	Inlet total pressure, atm	Inlet total temperature, K	Fuel temperature, K	Emission indices				Humidity g of water/g of air	NO <sub>x</sub> at zero humidity	Fuel-air ratio	Fuel-air ratio <sup>a</sup>	Combustion efficiency, percent		Reference Mach number, M <sub>4</sub>	NO <sub>x</sub> corrected to M <sub>4</sub> =0.075	Measured exhaust-gas temperature, K	Percent NO in NO <sub>x</sub>
				H/C	CO	CO <sub>2</sub>	NO <sub>x</sub>					Gas sample	Thermocouple				
33.1	4.11	844	292	0.03	1.23	3433	14.3	0.0032	15.2	0.0176	1.090	99.97	100.1	0.0754	15.3	1445	97.2
33.4	4.11	856	294	.01	.91	3477	14.4		15.3	.0175	1.104	99.98	-----	.0757	15.4	-----	97.2
32.9	4.11	837	360	0	1.03	3464	15.7		16.7	.0179	1.100		-----	.0748	16.7	-----	96.3
33.0	4.16	837	363		.98	3502	16.1		17.1	.0177	1.113		-----	.0741	16.9	-----	-----
33.1	4.05	842	475		.82	3435	16.4		17.4	.0177	1.090		-----	.0764	17.7	-----	-----
33.1	4.07	842	473		1.11	3416	16.1		17.1	.0178	1.085	99.97	100.4	.0761	17.4	1459	95.9
33.3	4.07	836	524		1.20	3405	16.2		17.2	.0175	1.081		-----	.0763	17.5	-----	-----
32.9	4.10	835	553		1.12	3420	16.5		17.5	.0178	1.086		-----	.0746	17.5	-----	-----
33.2	4.09	835	561		1.29	3450	16.9		18.0	.0177	1.096		-----	.0757	18.2	-----	-----
33.0	4.06	836	582		1.19	3413	16.5		17.5	.0178	1.083		102.4	.0758	17.7	1467	94.8
32.9	4.12	836	667		1.03	3568	18.1		19.2	.0149	1.133	99.98	100.7	.0744	19.1	1369	85
32.8	4.14	839	687		.85	3616	18.4		19.6	.0150	1.149	99.98	-----	.0739	19.3	-----	90
33.2	4.07	839	716		1.89	3532	17.5		18.6	.0121	1.122	99.96	-----	.0761	18.9	-----	-----
33.0	4.05	839	716		1.63	3356	16.5		17.5	.0127	1.065	99.96	-----	.0760	17.7	-----	-----
36.1	4.07	846	292		4.07	3035	13.42	.0060	15.0	.0105	.963	99.90	-----	.0801	16.0	-----	-----
35.9	4.08	846	292		1.40	3258	13.36	.0060	15.0	.0179	1.033	99.97	-----	.0790	15.8	-----	-----

<sup>a</sup>Ratio of gas sample to metered fuel-air ratios

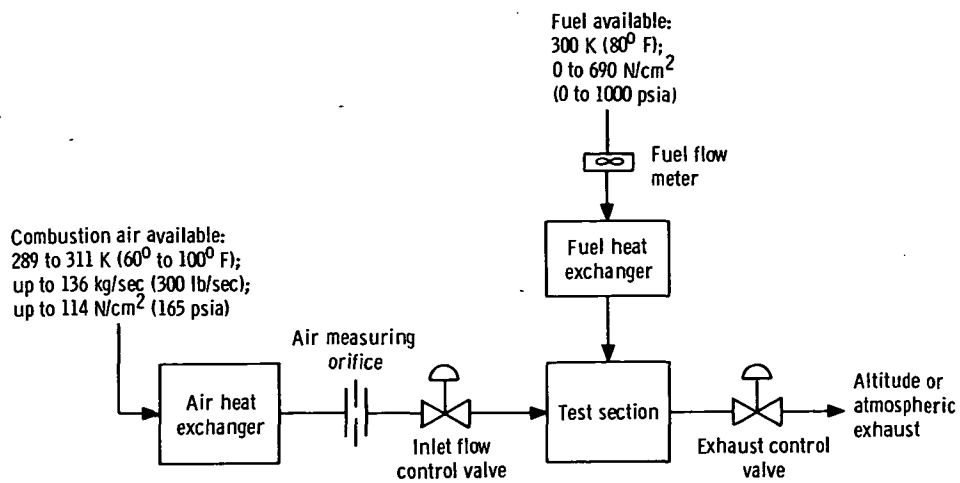

Figure 1. - Test facility.

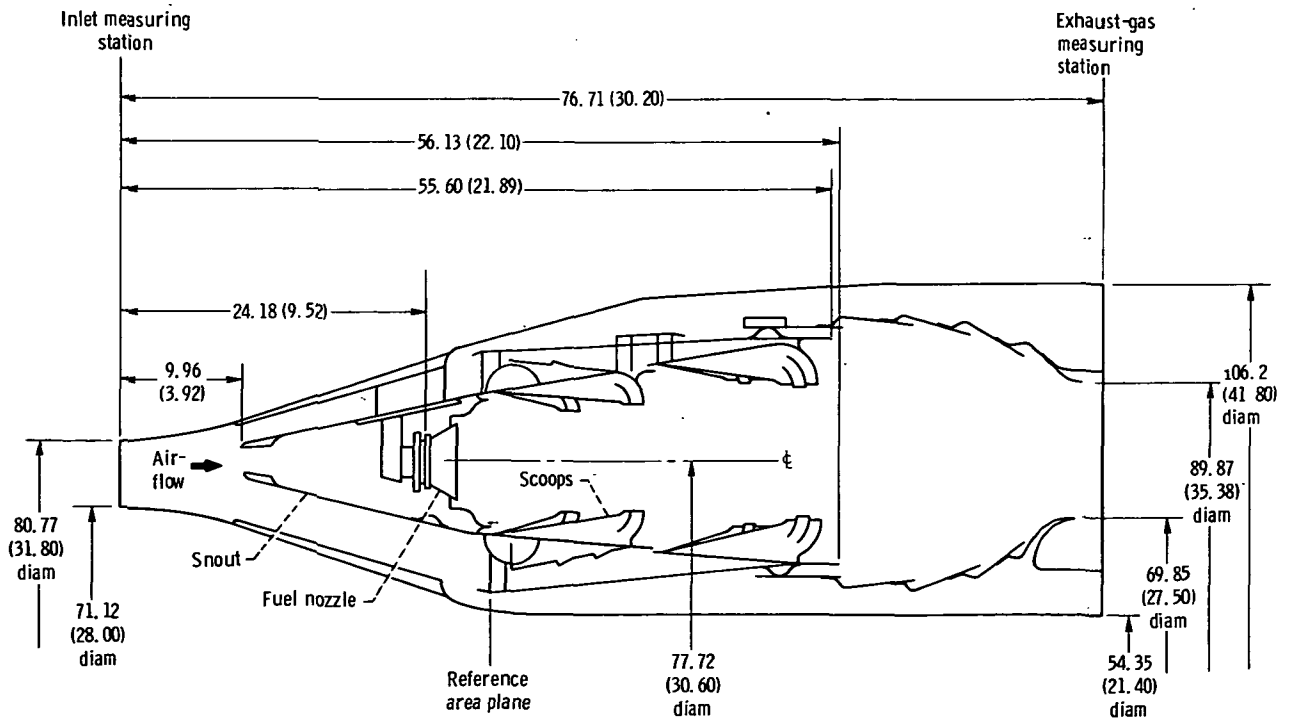
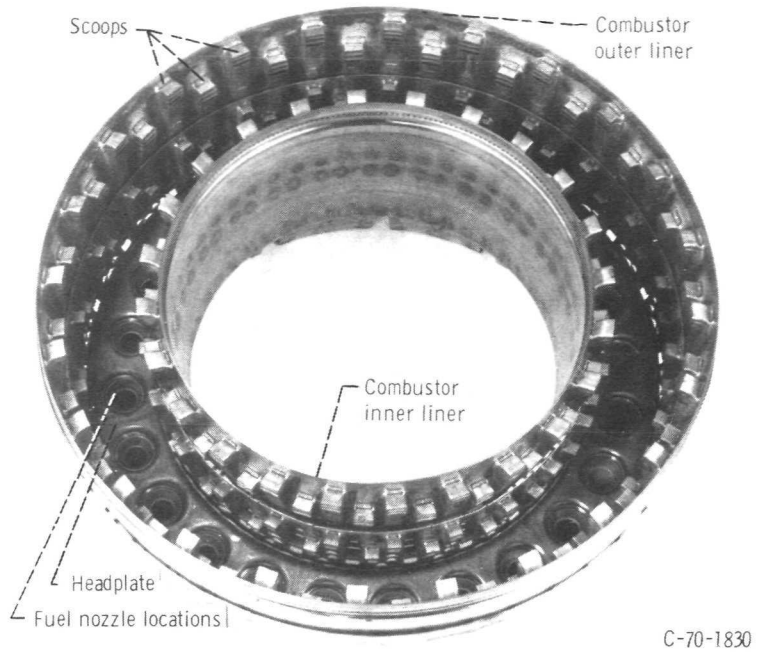
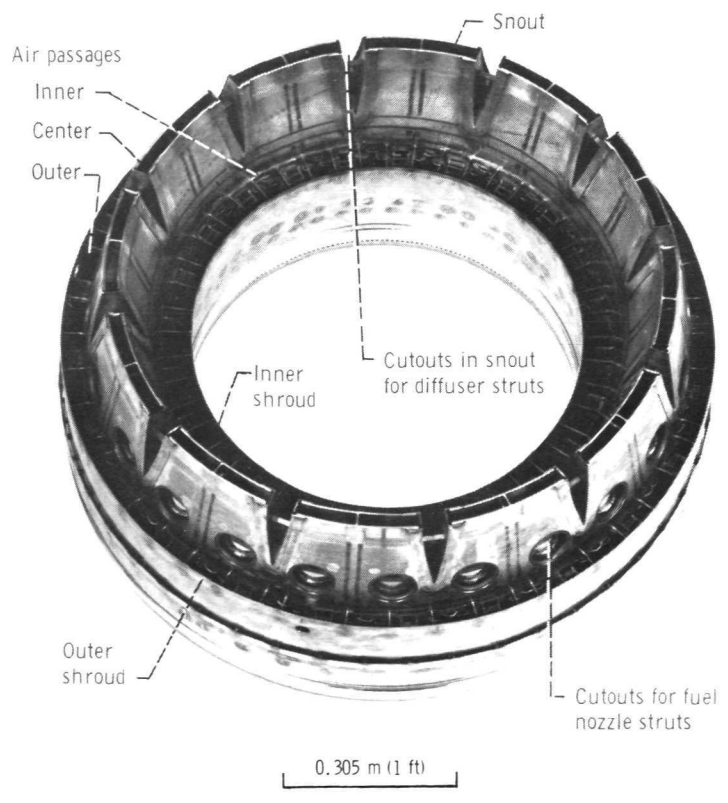

Figure 2. - Cross section of combustor. Dimensions are in cm (in.).

CD-11423-28



(a) View from downstream end.



(b) View from upstream end.

Figure 3. - Annular ram-induction combustor.

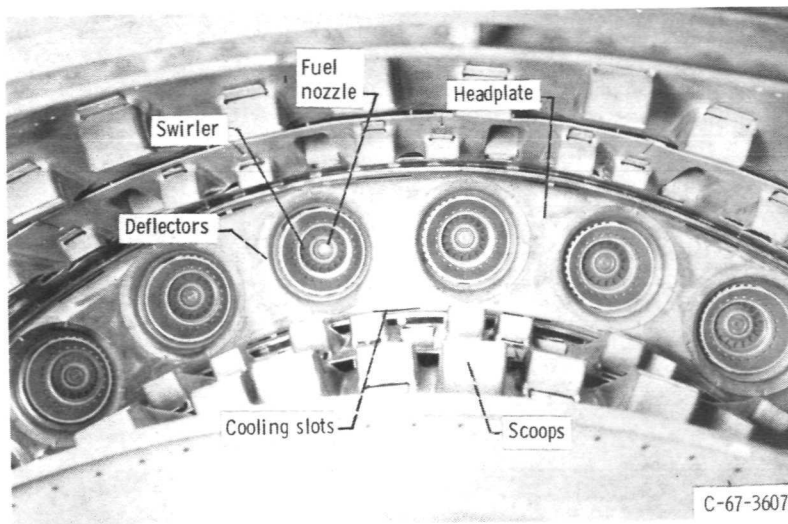

(c) Closeup view from downstream end.

Figure 3. - Concluded.

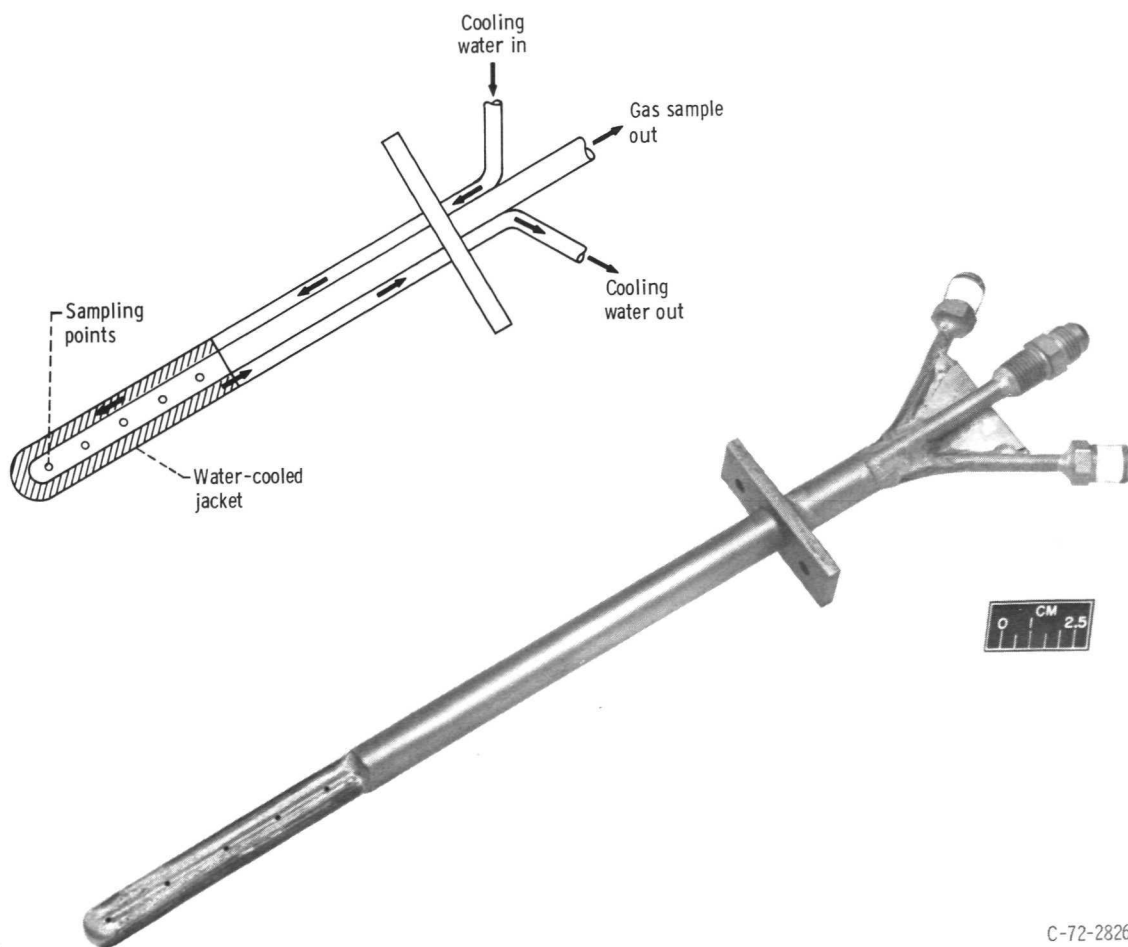
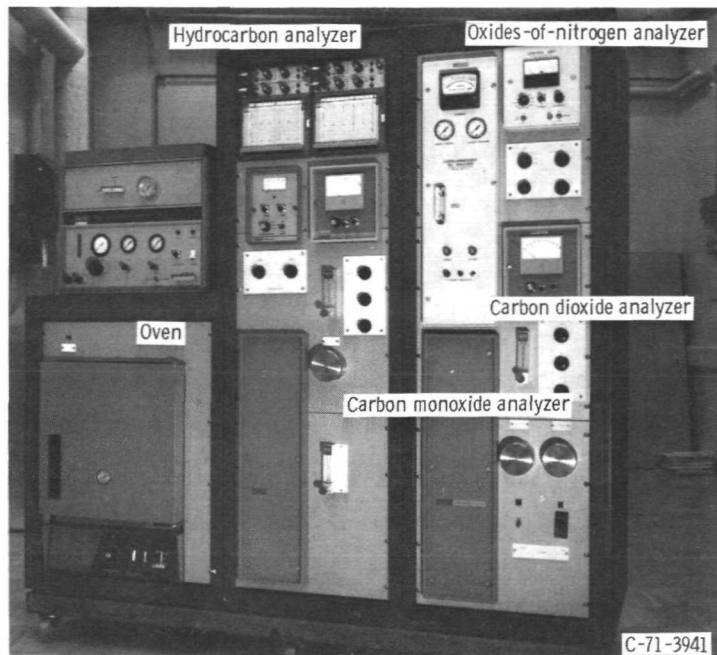
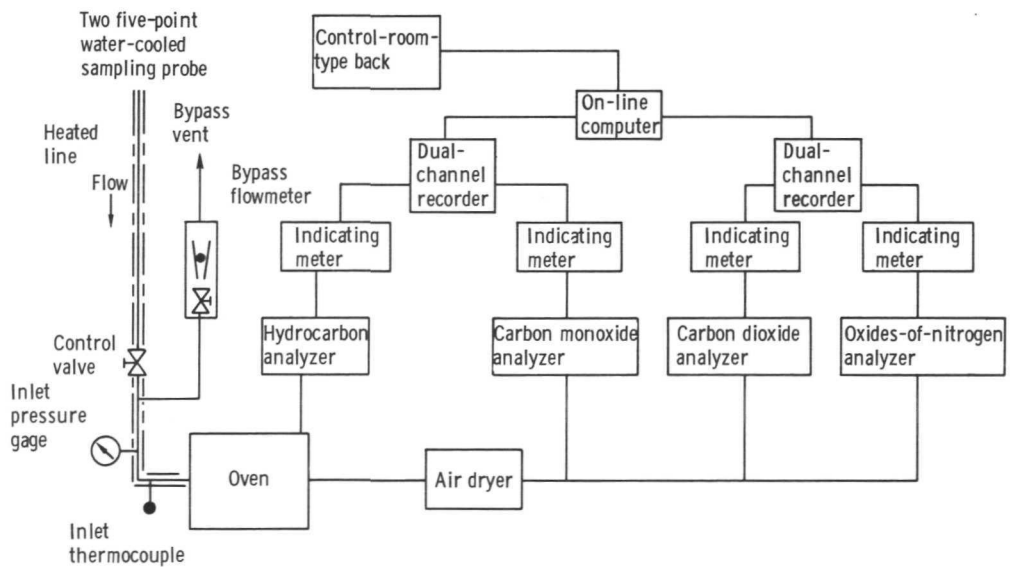

Figure 4. - Gas sampling probe.



(a) Instrument console.



(b) Schematic diagram.  
Figure 5. - Exhaust gas analyses system.



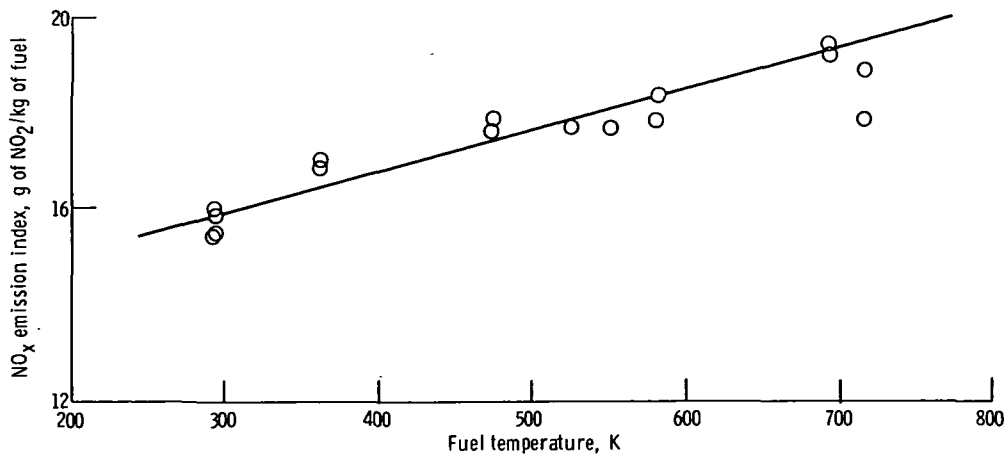

Figure 6. - Effect of fuel temperature on NO<sub>x</sub> emission index. Pressure, 4 atmospheres; reference Mach number, 0.075; inlet-air temperature, 838 K; zero humidity.

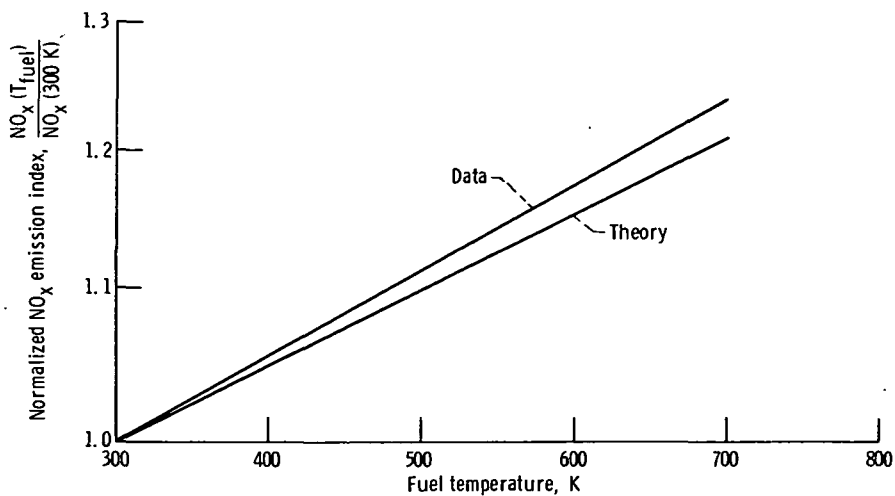

Figure 7. - Effect of fuel temperature on normalized NO<sub>x</sub> emission index - comparing data with theory. Theoretical flame temperature, approximately 2500 K; specific heat of theoretical flame, approximately 0.60.

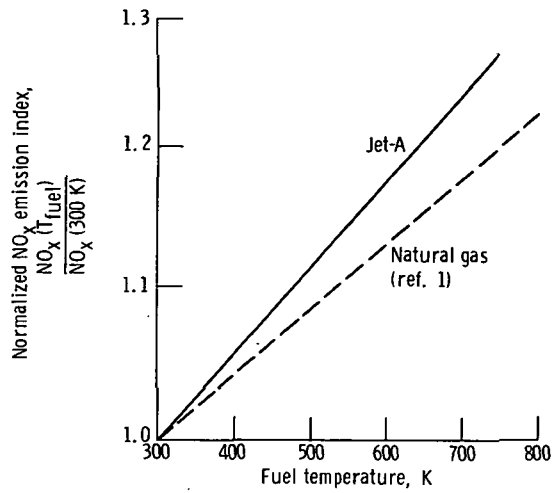

Figure 8. - Effect of fuel temperature on normalized NO<sub>x</sub> emission index for ASTM Jet-A and natural-gas fuels. Inlet-air temperature, 838 K.

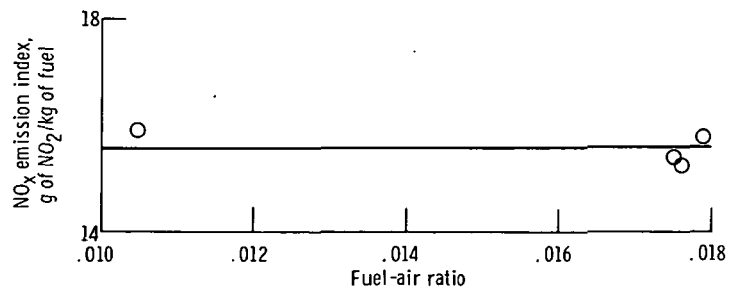

Figure 9. - Effect of fuel-air ratio on NO<sub>x</sub> emission index at ambient fuel temperature. Pressure, 4 atmospheres; reference Mach number, 0.075; inlet-air temperature, 838 K; zero humidity.



POSTMASTER: If Undeliverable (Section 158  
Postal Manual) Do Not Return

*"The aeronautical and space activities of the United States shall be conducted so as to contribute . . . to the expansion of human knowledge of phenomena in the atmosphere and space. The Administration shall provide for the widest practicable and appropriate dissemination of information concerning its activities and the results thereof."*

—NATIONAL AERONAUTICS AND SPACE ACT OF 1958

## NASA SCIENTIFIC AND TECHNICAL PUBLICATIONS

**TECHNICAL REPORTS:** Scientific and technical information considered important, complete, and a lasting contribution to existing knowledge.

**TECHNICAL NOTES:** Information less broad in scope but nevertheless of importance as a contribution to existing knowledge.

**TECHNICAL MEMORANDUMS:** Information receiving limited distribution because of preliminary data, security classification, or other reasons. Also includes conference proceedings with either limited or unlimited distribution.

**CONTRACTOR REPORTS:** Scientific and technical information generated under a NASA contract or grant and considered an important contribution to existing knowledge.

**TECHNICAL TRANSLATIONS:** Information published in a foreign language considered to merit NASA distribution in English.

**SPECIAL PUBLICATIONS:** Information derived from or of value to NASA activities. Publications include final reports of major projects, monographs, data compilations, handbooks, sourcebooks, and special bibliographies.

**TECHNOLOGY UTILIZATION PUBLICATIONS:** Information on technology used by NASA that may be of particular interest in commercial and other non-aerospace applications. Publications include Tech Briefs, Technology Utilization Reports and Technology Surveys.

*Details on the availability of these publications may be obtained from:*

**SCIENTIFIC AND TECHNICAL INFORMATION OFFICE**

**NATIONAL AERONAUTICS AND SPACE ADMINISTRATION**

**Washington, D.C. 20546**