

WIND POWER RESEARCH AT OREGON STATE UNIVERSITY

E. Wendell Hewson

Oregon State University
Corvallis, Oregon

The program of wind power research at Oregon State University commenced late in 1971 under the sponsorship of four Oregon Peoples Utility Districts, those of Central Lincoln, Tillamook, Clatskanie, and Northern Wasco. The interdisciplinary research team consists of faculty members from the Departments of Atmospheric Sciences, of Electrical Engineering, of Mechanical and Metallurgical Engineering, and of Physics, and from the School of Oceanography.

There have been two primary thrusts of the research effort to date, along with several supplementary ones. One primary area has been an investigation, in a preliminary manner, of the wind fields along coastal areas of the Pacific Northwest, not only at the shoreline but also for a number of miles inland and offshore as well. Estimates have been made of the influence of the wind turbulence as measured at coastal sites in modifying the predicted dependence of power generated on the cube of the wind speed. Wind flow patterns in the Columbia River Valley have also been studied but in less detail.

The second primary thrust has been to substantially modify and improve an existing wind tunnel to permit the build up of a boundary layer in which various model studies will be conducted.

One of the secondary studies involved estimating the cost of building an aerogenerator of the Smith-Putnam type at 1971 prices.

WIND PATTERNS AND SITING PROBLEMS

The wind patterns at a substantial number of coastal sites have been examined. Some of the wind stations were established by the present project, with locations chosen after examining the criteria set forth for the Vermont Smith-Putnam location (ref. 1) and for various coastal sites in Wales and Scotland (ref. 2). The locations of both the older and newly established wind stations are shown in figure 1.

The terrain of the coastal areas of Oregon bears a marked resemblance to that of western Wales and Scotland where a comprehensive wind power survey was conducted a number of years ago (ref. 2). The wind patterns are substantially different, however. The pressure gradients over the British Isles lead to west winds which blow up and over the

coastal higher ground. On the other hand, the pressure gradients over the coastal areas of the Pacific Northwest lead to prevailing northwest winds in summer and southwest winds in winter. The High Cascades beyond the Coast Range provide an additional barrier which tends to promote a lower level airflow parallel to the coast rather than perpendicular to it both summer and winter. As a result, the most promising wind power sites appear to be right on the coast or over nearby offshore waters.

Referring to figure 1, our research to date indicates that substantially stronger winds occur at our lower wind stations at Cape Foulweather and at Yaquina Head and at the Columbia Lightship, which is stationed several miles off the mouth of the Columbia River. Relatively high winds also occur over many of the bluffs which extend for several hundred miles along the coast of Washington, Oregon, and northern California.

Another attractive site for wind power development is the Columbia River Valley where limited studies only have been made. Topographic features along a stretch of the river valley east of Portland are illustrated in figure 2. The valley sides rise to heights of 4000 feet mean sea level (msl) to the south and perhaps 1600 feet msl to the north. On September 5, 1972, serial pilot balloon observations were made at three points in the valley, at Cascade Locks, Wyeth, and Viento Park whose locations are shown in figure 2. Balloons were released and tracked at each station at intervals of 1 to 2 hours during the day. The results are presented in figures 3 to 5. Each figure gives isotachs of equal up valley speed in knots. On this September day the winds in the valley appear to average about 20 knots (23 mph; 10 m/sec) if one allows for the tendency of the wind to increase with height. One purpose of these serial pilot balloon measurements was to determine whether or not significant large-scale turbulence occurs in the valley. One such region of turbulence is shown by the hatched area in figure 3 where a strong vertical gust caused the single theodolite method to fail. Future observations in the area will use two-theodolite tracking which avoids this problem. It is obviously important for wind power purposes to determine the magnitude and frequency of the occurrence of such gusts.

Two of the more attractive areas for wind power development are the offshore coastal waters and the Columbia River Valley, as suggested by the power duration curves presented in figure 6. The British aerometric survey referred to earlier showed one of the highest average wind speeds to be 21 knots (24 mph) at Rhossili Down, Glamorgan, Wales at a height of 633 feet (193 m) (ref. 2). The power duration curve for Rhossili Down is shown in figure 6 for comparison with corresponding curves for the Pacific Northwest. A power duration curve for an inland British station at a height of 267 feet (81 m) having limited wind power potential is also shown in figure 6.

The coastal terrain obviously has a substantial effect in slowing down the stronger offshore winds as the comparative data for the Columbia Lightship and Astoria (fig. 1) given in figures 6 and 7 show. The wind

records at two of the newly established wind stations, Cape Foulweather and Yaquina Head, do show high winds, but the instruments have not been in operation long enough to permit the establishment of reliable power duration curves. Details of these studies are available (ref. 3).

WIND TUNNEL STUDIES

The purpose of the wind tunnel studies is to develop appropriate simulation methods to the point that it will be possible to locate attractive coastal wind power sites from model studies without the necessity for taking lengthy and expensive on site observations. Analyses of various types of aerogenerators through the use of models will also be undertaken. Work to date has been directed to modifying and improving an existing return-flow wind tunnel to permit the buildup of a boundary layer in which the model studies can be conducted. A 1 to 300 accurate scale model of a portion of Yaquina Head on which one of our anemometers is located has been constructed and is ready for insertion in the tunnel. The enlarged tunnel, with its 5- by 4-foot test section 30 feet long, is shown in figure 8. Other information is also available (ref. 3).

TERRAIN MODIFICATION

One area to be investigated by wind tunnel studies is the possibility that terrain modification may result in appreciably augmented average wind speeds. The concept that will be explored is illustrated in figure 9. The diagram is self-explanatory.

AEROGENERATOR ARRAYS

Another area for exploration is the pros and cons of arrays of aerogenerators, especially of inexpensive, mass produced vertical rotor units. An inexpensive variant of the Savonius rotor is sketched in figure 10. The vertical hemicylinders, in sections of appropriate length, would consist of corrugated steel culverts cut in half. An array of such units is sketched in figure 11. The system of vertical rotors is maintained by guy wires as shown; the only compression members are the vertical shafts of the rotors which are themselves stiffened by the four hemicylinders. Each rotor drives directly, without the need for slip rings, a multipole generator of modern design which is housed below grade in a suitable enclosure.

Although the efficiency of such units is low, this may be more than offset by low cost and the need for little maintenance. Such arrays may be much larger than the one illustrated.

REFERENCES

1. Putnam, P. C.: Power from the Wind. New York, D. Van Nostrand, 1948.
2. Golding, E. W.: The Generation of Electricity by Wind Power. London, E. & F. N. Spon, 1955.

3. Hewson, E. W., et al.: Wind Power Potential in Selected Areas of Oregon. Report No. PUD 73-1, Oregon State Univ., Corvallis, Mar. 1973.

DISCUSSION

- Q: Professor, with respect to the electric utility industry, would you care to comment with reference to future, what the common objectives are?
- A: The Oregon PUD Directors Association allocated \$150,000 over three years. At the end of the end of this period they will probably consider a pilot program to get at least one windmill running.

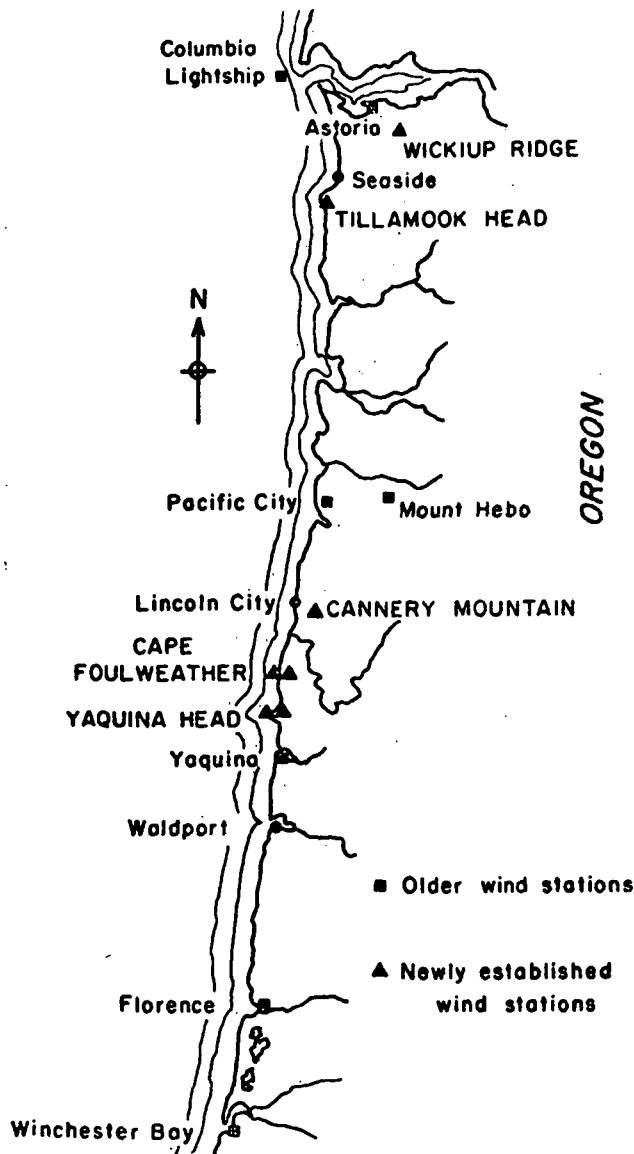

Fig. 1 Wind stations on or near the central and northern portions of the Oregon coast.

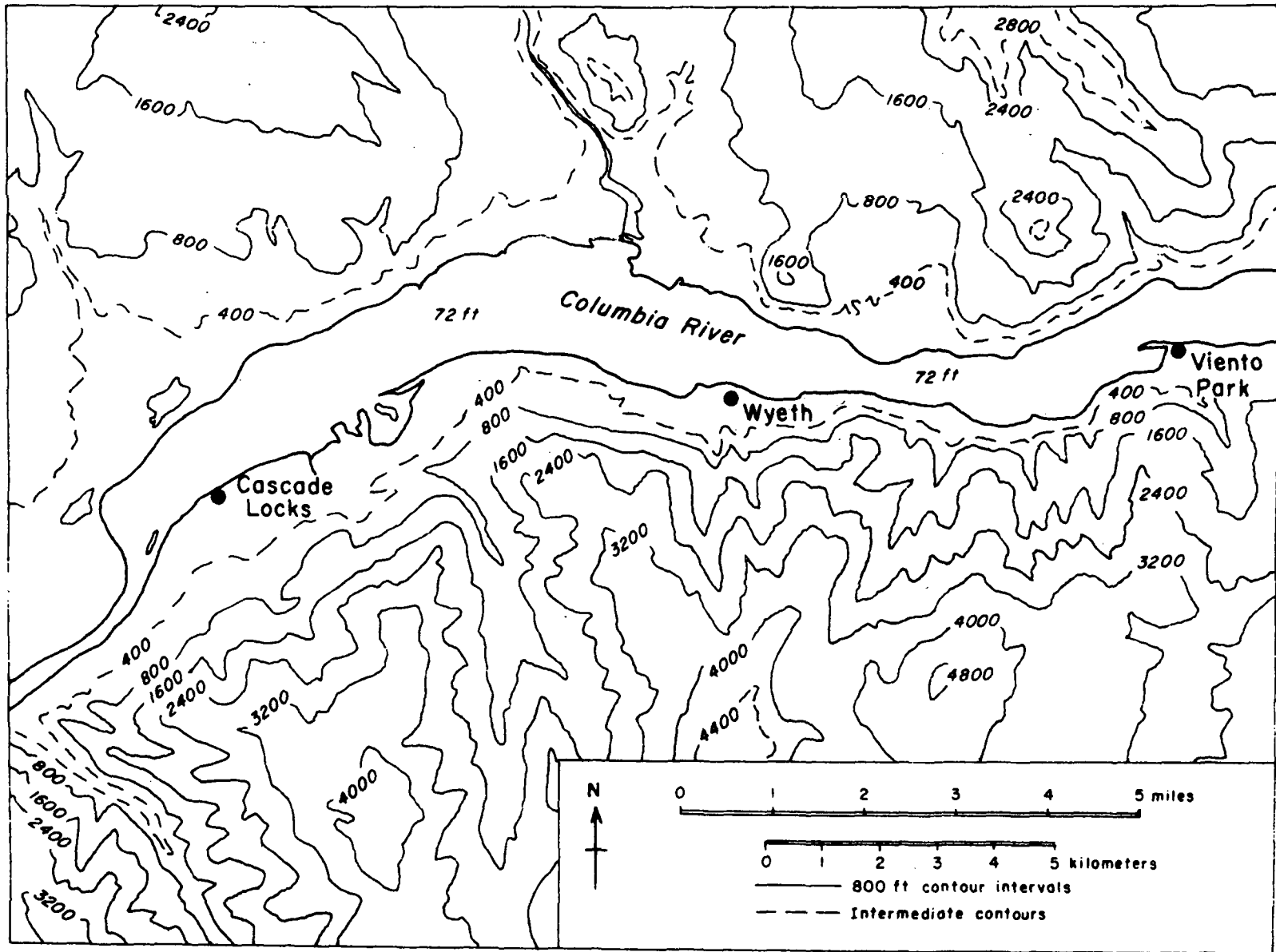

Fig. 2 The Columbia River Valley near Cascade Locks, Wyeth and Viento Park.

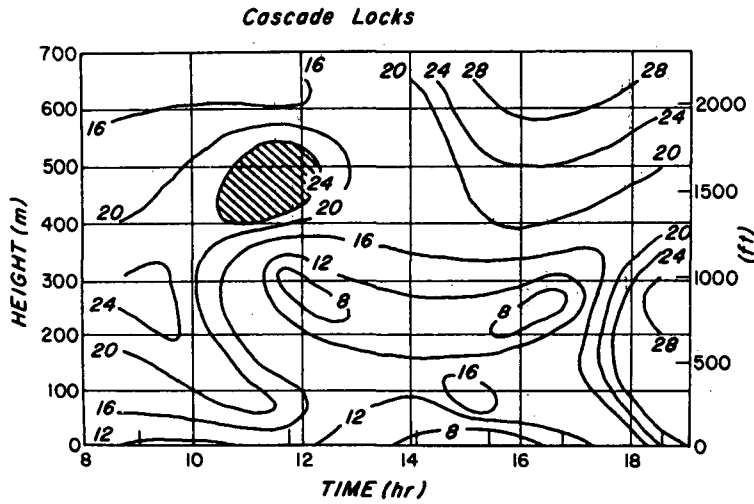

Fig. 3 Isolines of equal up valley wind speeds in knots on September 5, 1972 at Cascade Locks, Oregon

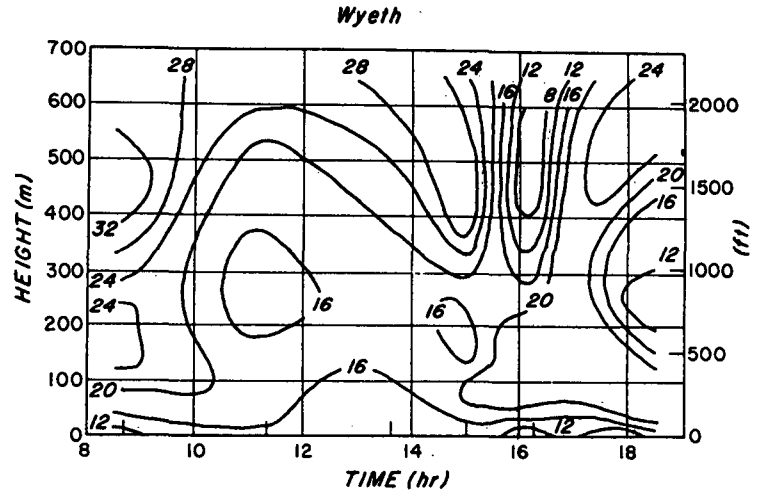

Fig. 4 Isolines of equal up valley wind speeds in knots on September 5, 1972 at Wyeth, Oregon

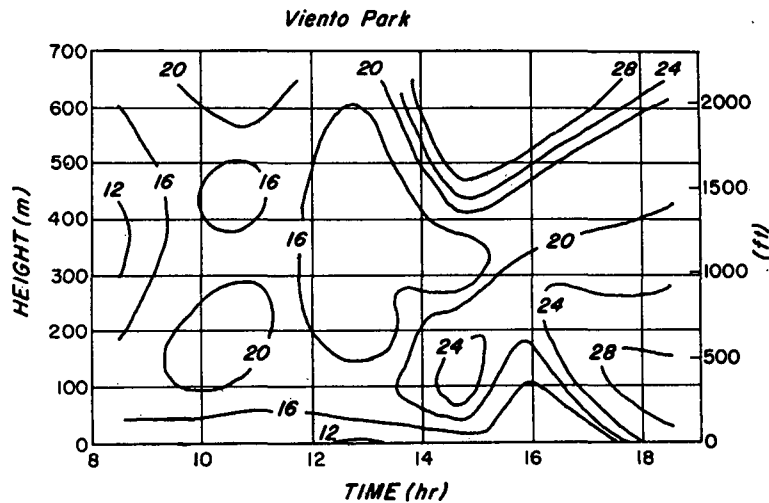

Fig. 5 Isolines of equal up valley wind speeds in knots on September 5, 1972 at Viento Park, Oregon

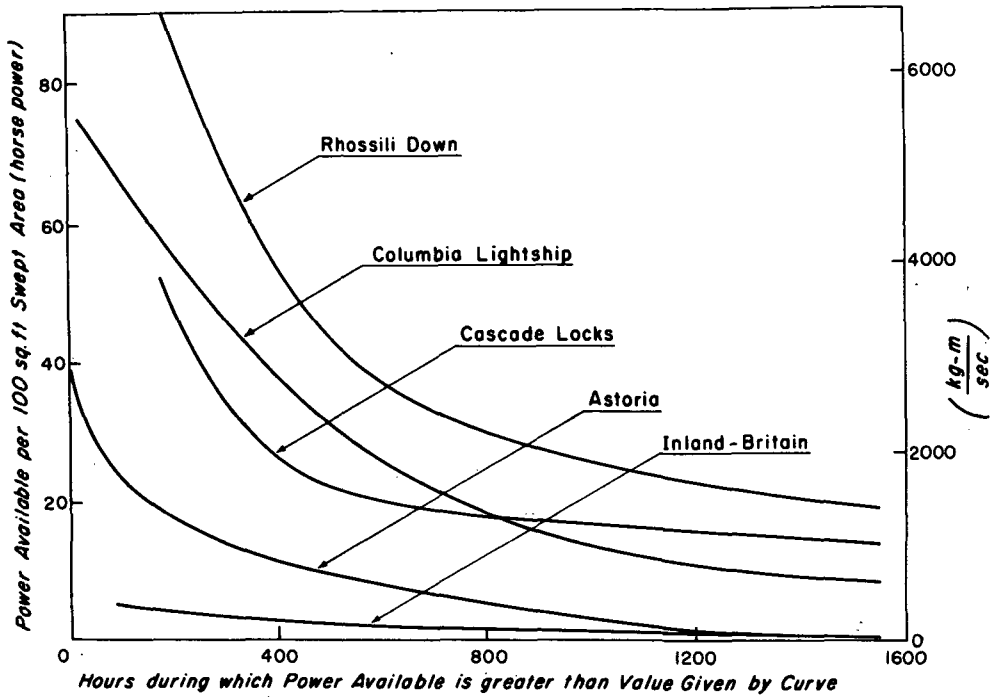

Fig. 6 Wind power duration curves for: Rhossili Down, Wales; the Columbia Lightship off the mouth of the Columbia River; Cascade Locks, Oregon; Astoria, Oregon near the mouth of the Columbia River; and an inland site in Great Britain.

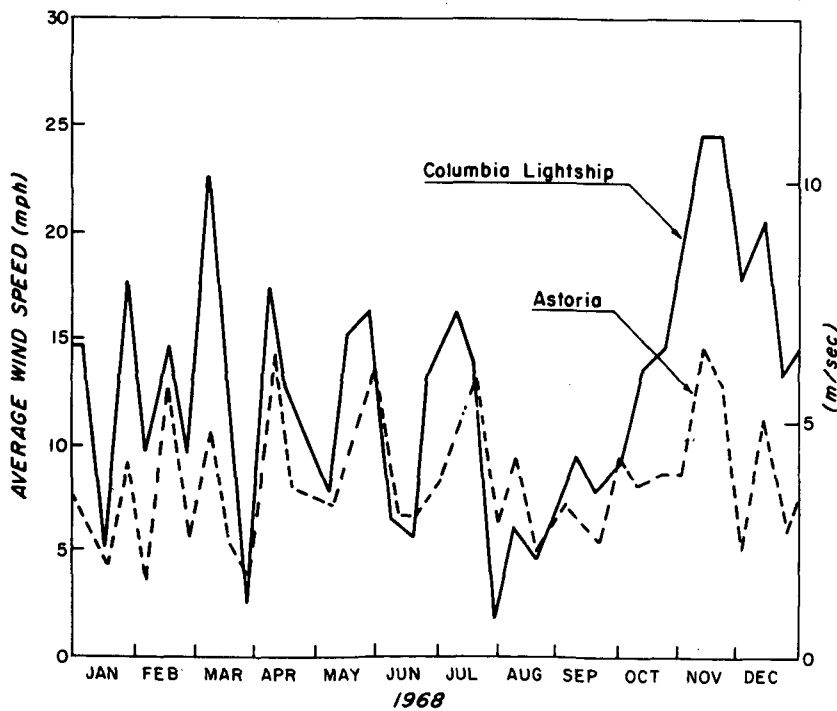

Fig. 7 Comparison of 1968 wind speeds at the Columbia Lightship with those at the nearby coastal station of Astoria



Fig. 8 The exterior of the test section of the wind tunnel; direction of air flow is from left to right.

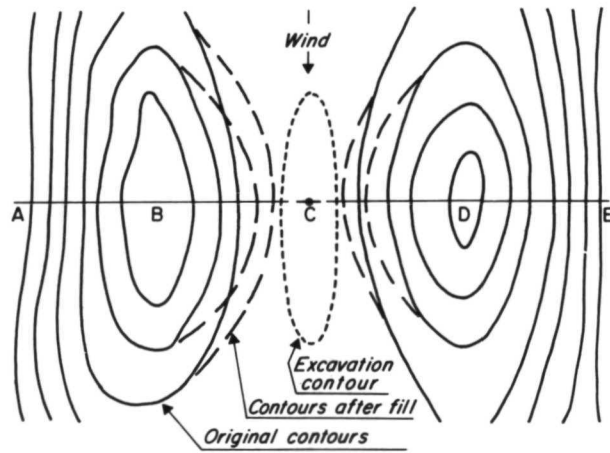

Fig. 9 Proposed type of terrain modification for the purpose of augmenting average wind speeds

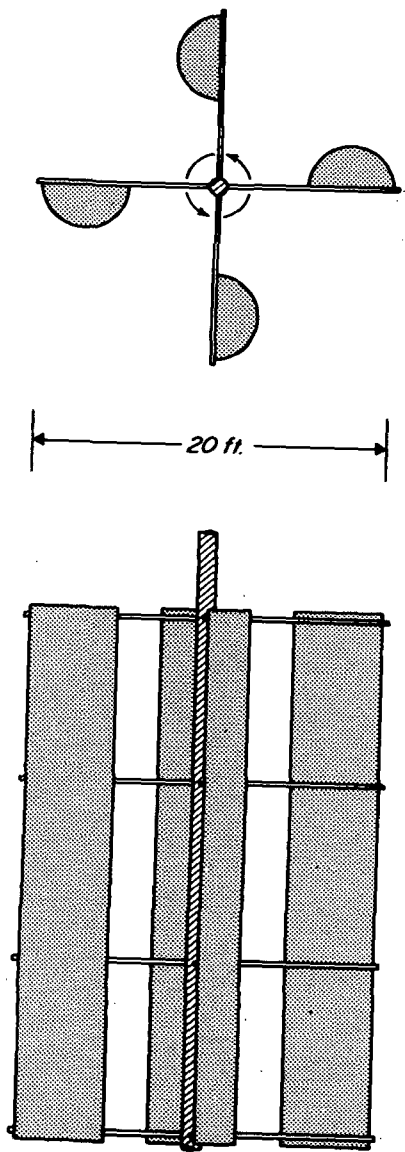

Fig. 10 A variant of the Savonius vertical rotor

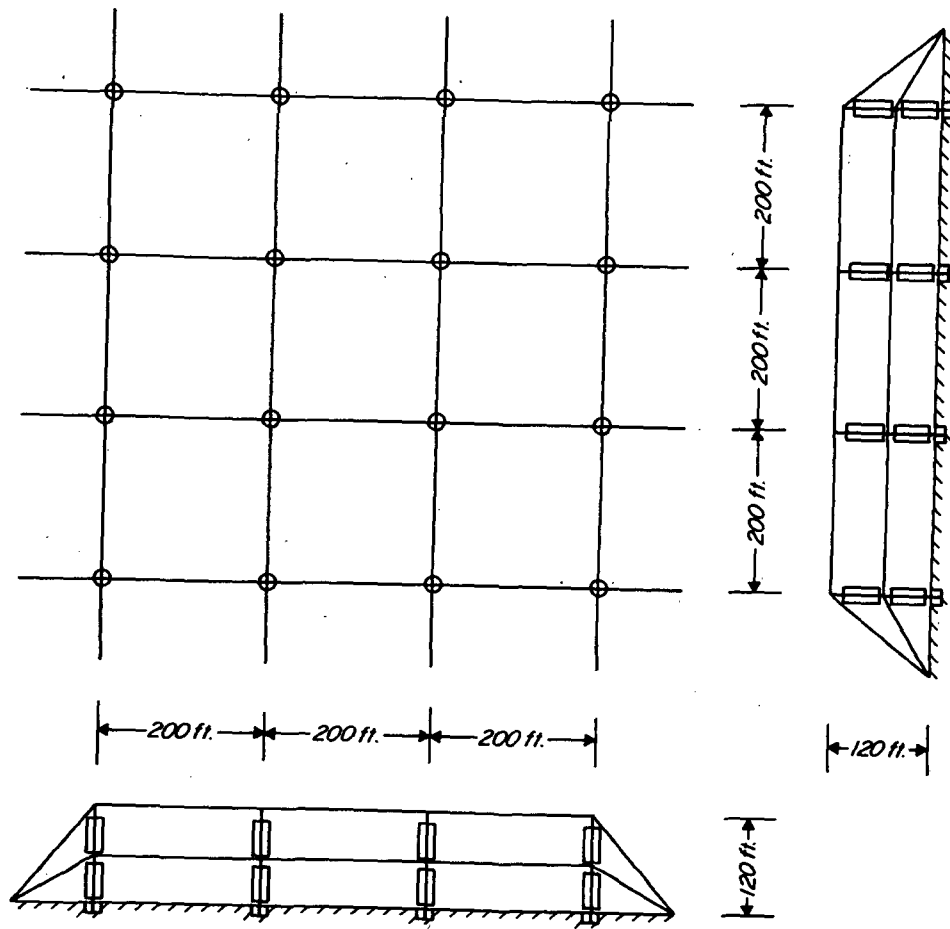

Fig. 11 A guyed array of inexpensive vertical rotor aerogenerators