

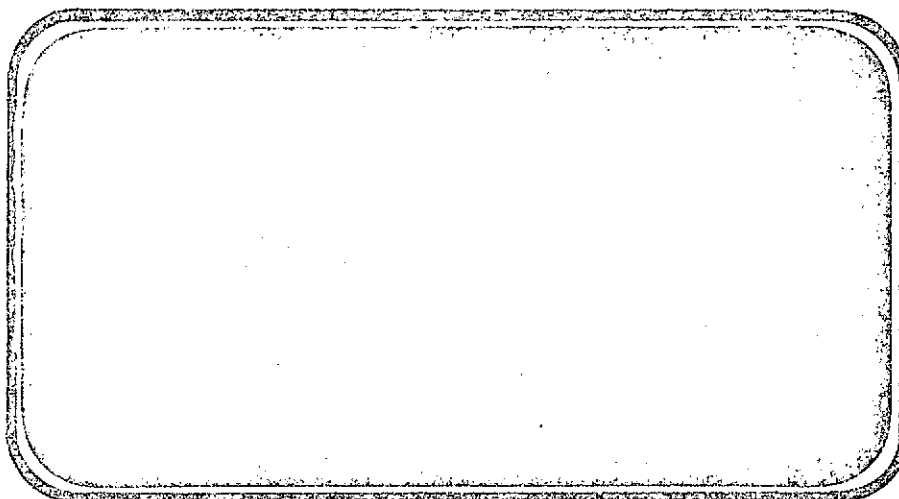

NATIONAL AERONAUTICS AND SPACE ADMINISTRATION



(NASA-CR-128762)	EFFECT OF GASEOUS AND	N74-18510
SOLID SIMULATED JET PLUMES ON A 040A		
SPACE SHUTTLE LAUNCH CONFIGURATION AT		
MACH NUMBERS FROM 1.6 TO 2.2 (Chrysler		Unclas
Corp.) 324 p HC \$19.25	CSCL 22B G3/31	31568

SPACE SHUTTLE

AEROTHERMODYNAMIC DATA REPORT

JOHNSON SPACE CENTER

HOUSTON, TEXAS

DATA MANAGEMENT services

SPACE DIVISION



CHRYSLER CORPORATION

December, 1973

DMS-DR-2013
NASA CR-128,762

EFFECT OF GASEOUS AND SOLID SIMULATED JET PLUMES
ON AN O40A SPACE SHUTTLE LAUNCH CONFIGURATION
AT MACH NUMBERS FROM 1.6 TO 2.2

By

Jules B. Dods, Jr., Jack J. Brownson, Kenneth L. Blackwell
John P. Decker, Donald L. Kassner and Barney B. Roberts

Prepared under NASA Contract Number NAS9-13247

by

Data Management Services
Chrysler Corporation Space Division
New Orleans, La. 70189

for

Engineering Analysis Division

Johnson Space Center
National Aeronautics and Space Administration
Houston, Texas

WIND TUNNEL TEST SPECIFICS

Test Number: ARC 97-616
NASA Series Number: IA2
Test Dates: 9 October to 3 November 1972

FACILITY COORDINATOR:

C. R. Nysmith
Ames Research Center
Moffett Field, California 94035

PROJECT ENGINEERS:

J. B. Dods, Jr.
J. J. Brownson
D. L. Kassner
Ames Research Center
Moffett Field, Calif. 94035

Phone: (415) 965-6215

J. P. Decker
Langley Research Center
Mail Stop 411
Hampton, Virginia 23365

Phone: (804) 827-3911

K. L. Blackwell
Marshall Space Flight Center
S&E-AERO-AAE, Bldg. 4610
Huntsville, Alabama 35812

Phone: (205) 453-2517

B. B. Roberts
Johnson Space Center
Code EX3
Houston, Texas 77058

Phone: (713) 483-5973

DATA MANAGEMENT SERVICES:

This document has been prepared by:

for M. J. Lanfranco, V. W. Sparks
Liaison Operations

Alan T. Kavanaugh
Data Operations

[Signature]

[Signature]

This document has been reviewed and is approved for release.

FORN. D. Kemp
Data Management Services

[Signature]

Chrysler Corporation Space Division assumes no responsibility for the data presented herein other than its display characteristics.

EFFECT OF GASEOUS AND SOLID SIMULATED JET PLUMES
ON AN O40A SPACE SHUTTLE LAUNCH CONFIGURATION
AT MACH NUMBERS FROM 1.6 TO 2.2

By Jules B. Dods, Jr.*, Jack J. Brownson*, Kenneth L. Blackwell**,
John P. Decker***, Donald L. Kassner*, and Barney B. Roberts****

Ames Research Center

ABSTRACT

An experimental investigation was conducted in the Ames 9- by 7-Foot Supersonic Wind Tunnel to determine the effect of plume-induced flow separation and aspiration effects due to operation of both the orbiter and the solid rocket motors on a 0.019-scale model of the launch configuration of the Space Shuttle Vehicle. Longitudinal and lateral-directional stability data were obtained at Mach numbers of 1.6, 2.0, and 2.2 with and without the engines operating. The plumes exiting from the engines were simulated by a cold gas jet supplied by an auxiliary 200 atmosphere air supply system, and by solid body plume simulators. Comparisons of the aerodynamic effects produced by these two simulation procedures are presented. The data indicate that the parameters most significantly affected by the jet plumes are the pitching moment, the elevon control effectiveness, the axial force, and the orbiter wing loads. It is shown that the solid rocket motor (SRM) plumes have the largest effect on the aerodynamic characteristics. The effect of the orbiter plumes in combination with the SRM plumes is, however, also significant. It is shown that variations in

the nozzle design parameters can be used to reduce plume-induced aerodynamic effects. It is suggested that configuration design changes, such as a more rearward location of the SRM nozzles, should produce smaller plume-induced effects.

The tests were conducted at angles of attack from -4° to 10° and at angles of sideslip from -4° to 6° . Flow visualization studies were made to determine the extent of flow separation on the wing and body caused by the jet plumes. The vapor-screen technique was used to show the cross sectional shape of the operational plumes at various distances from the nozzle exit for a limited range of angles of attack.

*NASA, Ames Research Center

**NASA, Marshall Space Flight Center

***NASA, Langley Research Center

****NASA, Johnson Space Center

TABLE OF CONTENTS

	Page
ABSTRACT	iii
INDEX OF MODEL FIGURES	3
INDEX OF DATA FIGURES	4
NOMENCLATURE	6
INTRODUCTION	10
TEST FACILITY	12
MODEL DESCRIPTION	13
PLUME SIMULATION	14
TESTING AND PROCEDURE	17
RESULTS AND DISCUSSION	19
CONCLUSIONS	28
REFERENCES	30
TABLES	
1. MODEL GEOMETRY	31
2. MODEL NOZZLE GEOMETRY	34
3. SRM SOLID PLUME SHAPES	36
4. PROTOTYPE NOZZLE-MOTOR CHARACTERISTICS	37
5. LAUNCH TRAJECTORY CONDITIONS	38
6. EXPERIMENTAL SRM PLUME SHAPES AND TEST CONDITIONS	39
7. NOZZLE TEST CONDITIONS	46
8. DATA SET COLLATIONS	48

TABLE OF CONTENTS - continued

	Page
FIGURES	
MODEL	51
DATA	65
APPENDIX	
TABULATED DATA LISTING	

INDEX OF MODEL FIGURES

Figure	Title	Page
1	Axis systems	51
2	Model description	
(a)	O40A Integrated vehicle	52
(b)	Orbiter	53
(c)	Orbiter fuselage	54
(d)	EHOT	55
(e)	Solid rocket motors, S1	56
(f)	Vertical tail ACPS pods P1V	57
(g)	SRM plumes	58
3	Installation of the 0.019-scale model launch configuration of the Space Shuttle Vehicle with the O40A orbiter	
(a)	Front view	59
(b)	Rear view	60
(c)	Front view with M = 1.4 nozzle design solid plume simulators	61
4	Average plume shape variations with the viscous mixing parameter $(\rho U)_j / (\rho U)_\infty$ for various SRM nozzle designs at M = 1.6.	62
5	Average SRM plume shape variations with the viscous mixing parameter $(\rho U)_j / (\rho U)_\infty$ for M = 2.0 nozzle design at M = 2.0	63
6	Variation of the average gaseous SRM plume shape with the viscous mixing parameter at a given distance from the nozzle exit	64

INDEX OF DATA FIGURES

Figure	Title	Page
7	Effect of plume size on longitudinal characteristics	1-12
8	Effect of plume size on lateral characteristics, Alpha = 0.0	13-22
9	Effect of nozzle design point on longitudinal characteristics	23-27
10	Effect of orbiter and SRM plumes on longitudinal characteristics, Beta = 0.0	28-39
11	Effect of orbiter and SRM plumes on lateral characteristics	40-50
12	Comparison of gaseous and solid SRM plumes	51-60
13	Comparison of control effectiveness with gaseous and solid SRM plumes	61-70
14	Plume effects with and without OMS	71-80
15	Effect of alpha on lateral characteristics with plumes OMS on	81-85
16	Effect of alpha on lateral characteristics with plumes OMS off	86-90
17	Effect of plumes on elevon and rudder power, Beta = 0.0	91-116
18	Effect of plumes on <u>elevon and rudder</u> power, Alpha = 0.0	117-132
19	Effect of plumes on aileron power, Beta = 0.0	133-140
20	Effect of plumes on aileron power, Alpha = 0.0	141-150
21	Effect of plume size on elevon and rudder power, Beta = 0.0	151-166
22	Effect of plume size on elevon and rudder power, Alpha = 0.0	167-176

INDEX OF DATA FIGURES

Figure	Title	Page
23	Effect of orbiter and SRM plumes on elevon and rudder power, Beta = 0.0	177-192
24	Effect of orbiter and SRM plumes on elevon and rudder power, Alpha = 0.0	193-202
25	Effect of plumes on elevon effectiveness	203-204
26	Effect of plumes on rudder effectiveness	205-208
27	Effect of plumes on aileron effectiveness	209-210

NOMENCLATURE

The axis system and sign convention are shown in figure 1. Owing to the limitations of the computer notation system in plotting data, conventional aerodynamic symbols have been replaced by plot symbols in the data figures as noted in the following list.

<u>Symbol</u>	<u>Plot Symbol</u>	<u>Definition</u>
b		wing span, m
\bar{c}		mean aerodynamic chord, m
C_N	CN	normal-force coefficient, normal force/qS
C_A	CA	axial-force coefficient, axial force/qS
C_Y	CY	side-force coefficient, side force/qS
C_{A_b}	CAB	base force coefficient, $(\text{base force} - A_b(p_b - p_\infty))/qS$
C_{A_f}	CAF	forebody axial-force coefficient, $C_A - C_{A_b}$
C_m	CLM	pitching-moment coefficient, pitching moment/qS \bar{c}
C_n	CYN	yawing-moment coefficient, yawing moment/qSb
C_l	CBL	rolling-moment coefficient, rolling moment/qSb
	CWBM	wing root bending-moment coefficient, bending moment/qS \bar{c}
AR		aspect ratio
B.L.		butt line, orbiter wing reference plane, m
F.S.		fuselage station, m
W.L.		water line, m

L		length of hydrogen-oxygen tank, m
M	MACH	free-stream Mach number
q		free-stream dynamic pressure, N/m^2
r_e		radius of nozzles at exit plane, m
r_u		radius of upper gaseous plume boundary, m
r_l		radius of lower gaseous plume boundary, m
\bar{r}		average gaseous plume boundary, $(r_u + r_l)/2$, m
S		wing area, m^2
x		longitudinal distance downstream of nozzle exit plane, m
	XCP/L	center of pressure
α	ALPHA	angle of attack, degrees
β	BETA	angle of sideslip, degrees
δ_a	AILRON	aileron deflection, degrees
δ_e	ELEVON	elevon deflection, degrees
δ_r	RUDDER	rudder deflection, degrees
$(\rho U)_j$		density velocity product of jet at exit plume boundary, $N/m^2 - sec.$
$(\rho U)_\infty$		tunnel freestream density velocity product, $N/m^2 - sec.$
(P_c/P_{t_∞})	PC/PT	ratio of engine chamber pressure to tunnel total pressure
$(P_c/P_t)_{set}$	PC/PT	ratio as set
(P_c/P_e)		ratio of engine chamber pressure to nozzle exit static pressure

$(P_c/P_t)_{cal}$		$(P_c/P_t)_{set}$ (Calibration factor), where calibration factor = $(P_c/P_e)_{theory} / (P_c/P_e)_{exper.}$
	NOM	nominal or design PC/PT
A/A*	A/A	ratio of nozzle exit area to minimum throat area
	SRM	solid rocket motors
	ORB	orbiter
	TNK	hydrogen-oxygen tank
$\frac{\Delta C_l}{\Delta \delta_a}$	DCBL	rolling-moment coefficient increment due to control surface deflection.
	DCBLP	rolling-moment coefficient increment due to control surface deflection in presence of plumes.
$\frac{\Delta C_y}{\Delta \delta_r}$	DCYN	yawing-moment coefficient increment due to control surface deflection.
	DCYNP	yawing-moment coefficient increment due to control surface deflection in presence of plumes.
$\frac{\Delta C_m}{\Delta \delta_e}$	DCLM	pitching-moment coefficient increment due to control surface deflection.
	DCLMP	pitching-moment coefficient increment due to control surface deflection in presence of plumes.
	DCBLA	ratio of rolling-moment increments due to aileron deflection, plume on divided by plume off.
	DCBLR	ratio of rolling-moment increments due to rudder deflection, plume on divided by plume off.
	DCYNR	ratio of yawing-moment increments due to rudder deflection, plume on divided by plume off.
	DCLME	ratio of pitching-moment increments due to elevator deflection, plume on divided by plume off.

$C_{l\beta}$

DCBLDB

slope of rolling-moment coefficient vs. angle of sideslip.

$C_{n\beta}$

DCYNDB

slope of yawing-moment coefficient vs. angle of sideslip.

INTRODUCTION

During the ascent, or launch, phase of the Space Shuttle Vehicle trajectory, both the orbiter main propulsion systems and the large solid rocket motor boosters are in operation. The plumes formed by the exhaust gases of these boosters have been shown to induce flow separation over the aerodynamic control surfaces of the orbiter vehicle. This flow separation causes a reduction in the vehicle aerodynamic control effectiveness and an increase in the vehicle aerodynamic loads, both static and dynamic. In order to investigate the magnitude and significance of these plume-induced effects, tests were conducted in the Ames Research Center's 9- by 7-Foot Supersonic Wind Tunnel on a 0.019-scale model of the JSC O40A Space Shuttle Vehicle in the ascent configuration with provisions for both gaseous and solid simulation of the exhaust plumes. The tests were conducted at Mach numbers of 1.6, 2.0 and 2.2, at angles of attack from -4° to 10° , and at angles of sideslip from -4° to 6° .

Solid plume simulation tests on the same scale model have been conducted previously in the Ames 9- by 7-Foot SWT and the 11- by 11-Foot TWT, and the results have been presented in reference 1. For purposes of the present investigation, tests utilizing the solid plumes for $M = 1.4$ and 1.6 of the reference tests were repeated inasmuch as the pitching moments would not be comparable because, for the present tests, the nozzle pressure loads were not being measured by the force balance. The nozzles and their pressure chambers were an integral portion of the supporting sting. The solid plume shapes were predicted from reference 2.

In addition to the basic objective of obtaining the longitudinal and lateral aerodynamic stability characteristics and the vehicle control effectiveness with and without the exhaust plume simulation, wing root bending-moment increments were obtained, and a study was conducted of the off-design variations such as the number of engines operating, the area ratio, and altitude.

TEST FACILITY

The Ames 9- by 7-Foot Supersonic Wind Tunnel is of the closed-return, variable-density type with a 9- by 7-foot rectangular test section. The nozzle is of the asymmetric, sliding-block type in which the variation of the Mach number is achieved by streamwise translation of the fixed contour block that forms the floor of the nozzle. The Mach number range of this test facility is continuously variable from 1.55 to 2.5. This facility can be operated at unit Reynolds numbers from 3.9370×10^6 to 21.325×10^6 per meter.

MODEL DESCRIPTION

The 0.019-scale model of the Space Shuttle Vehicle launch configuration consisted of a JSC 040A orbiter combined with an external hydrogen-oxygen tank (EHOT, 8.2885 m diameter, full-scale) and two externally mounted solid rocket motors (SRM, 3.9624 m diameter, full-scale). The details of the model are shown in figures 2(a) through 2(g) and pertinent full-scale and model-scale dimensions are given in table 1. The model nozzle geometry is given in table 2. Front and rear views of the model installed in the tunnel are given in figures 3(a) and 3(b), and a front view of the model with $M = 1.4$ nozzle design solid plume simulators is shown in figure 3(c). Solid plume simulators were used to compare the test results with gaseous plumes. The solid plume simulators designed for $M = 1.4$ and 1.6 are shown in figure 2(h) and the coordinates are given in table 3. One wing of the orbiter was instrumented with strain gages to measure wing-bending moments.

PLUME SIMULATION

Both the orbiter and the SRM propulsion system exhaust plumes were simulated by air expanding from supersonic nozzles supplied by a high-pressure (200 atmospheres) air system. The supersonic nozzles were designed based on consideration of: (1) calculated prototype plume shapes and flow characteristics; (2) application of plume simulation criteria; and (3) vehicle model limitations. The prototype plume shapes were calculated using Lockheed's Method-of-Characteristics Computer Program (VOFMOC), reference 3. The orbiter and SRM motor characteristics used as input to this program are summarized in table 4. These characteristics represent the best available data for the engine operating conditions and nozzle configurations.

Specific motor-nozzle specifications were not available for the SRM's. Therefore, calculation of the SRM plumes was based on the nozzle exit conditions determined only from nozzle area ratio and exit lip angle information. Equilibrium chemistry data for use with the VOFMOC program were calculated using the NASA-Lewis Chemical Equilibrium Chemistry (CEC) program, reference 4. A propellant composition representative of prior SRM systems was utilized. The chamber pressure of the SRM motor decreases with time as shown in table 4. Therefore, a unique set of equilibrium chemistry data was used at each trajectory point. Newtonian pressure conditions were assumed to define the SRM plume boundaries. The freestream flow was assumed to be uniform and parallel to the nozzle centerline. No attempt was made to consider two-phase flow effects in the flow field calculations.

SRM prototype plume boundary shapes were determined for the trajectory conditions listed in table 5.

Design of the model nozzles was an iterative process. Design criteria for the model nozzles were the plume shape similarity parameters found in reference 5. The objective of these similarity parameters is to match the overall prototype plume shape as closely as possible. However, due to a one-dimensional flow assumption that was used in the model nozzle design procedures, prototype values of the similarity parameters were not duplicated by the model nozzles. It was found, through parametric calculations, that the prototype plume shapes could be satisfactorily matched by the model nozzles even though the similarity parameters of reference 5 were not duplicated. In fact, this investigation revealed that all prototype plume shapes could be produced by each of the model nozzles whereas the criteria of reference 5 require a different nozzle for each plume shape. This gave the ability, at least theoretically, to hold plume shapes constant and to investigate the effects of other plume parameters upon base pressure and plume-induced separation.

Consideration of the limitations dictated by the vehicle model design required a modification to the simulation criteria. In the case of the SRM, the conical model nozzle area ratio was held constant and the angle of the conical nozzle section and the model chamber pressure were varied to satisfy plume boundary simulation. This procedure permitted the nozzle exit dimension to remain constant and the nozzle overall length to remain within acceptable limits.

Simulation of the orbiter plume shapes more closely followed the established criteria. Nozzle length limitations dictated by vehicle model considerations required the use of contoured nozzles. To satisfy this requirement the prototype orbiter contour was scaled down and utilized. Model area ratio was changed by varying the model throat size and fairing the nozzle throat into the scaled contour. Model chamber pressure was then varied in order to match the prototype plume boundary shapes.

TESTING AND PROCEDURE

The model was sting mounted through the base of the external hydrogen-oxygen tank, and force and moment data were obtained from an internally mounted six-component strain gage balance. The moment center was 0.5005 m aft of the EHOT nose and was 0.02316 m above the centerline (figure 2(a)). The nozzles and the nozzle pressure chambers for both the orbiter and the SRM's were an integral portion of the sting, and thus the forces and pressures on the nozzles were not measured on the strain-gage balance. Base and cavity chord force corrections were, however, applied to the data. The jet plumes generated from the SRM's and the orbiter engines were simulated with cold air supplied by the tunnel auxiliary 200 atmosphere air supply system. The SRM's and the orbiter engines were independently supplied by using a compartmented sting design. The tunnel total pressure conditions were dictated by the capacity of the auxiliary air supply system to set nozzle design pressure ratios (P_c/P_{t_∞}) as well as for the under and overexpanded pressure ratios tested to illustrate the effect of plume size. The high mass and pressure addition to the tunnel circuit caused the tunnel total pressure to rise considerably during a "blow" of the model engines. Special operational procedures were thus required. After sufficient experimentation with the tunnel pressurizing air system, it was found possible to maintain nearly constant tunnel total pressure during a data-taking sequence by continuous suction on the tunnel circuit.

Data were obtained at Mach numbers of 1.6, 2.0 and 2.2 for angles of attack from -4° to 10° and angles of sideslip from -4° to 6° with and

without the gaseous plume simulation. In addition data were obtained for solid plume simulation at a free stream Mach number of 1.6 using $M = 1.4$ and 1.6 solid plume simulators. Fluorescent oil-flow studies of the upper and lower surfaces of the orbiter wing and body were made with and without the gaseous flow simulation.

Transition was artificially induced on the vehicle by applying spherical roughness elements to the wing, the tail, and the noses of the EHOT, the SRM's, and the orbiter. The roughness elements were about 2.6924×10^{-4} m in diameter and were located about 0.0254 m aft of the nose of the EHOT, the nose of the SRM's, and the nose of the orbiter. The strips of roughness on the wings and tail were also about 0.0254 m aft of the leading edges.

As previously mentioned, the model was tested with different design Mach-number nozzles to simulate plume shapes larger and smaller than the prototype plume shape. A tabulation of experimentally measured plume shapes derived from schlieren photograph measurements is given in table 6. The nozzle test conditions are given in table 7.

RESULTS AND DISCUSSION

The objectives of the present test were to obtain longitudinal and lateral stability characteristics and rudder, aileron and elevator control effectiveness, and wing root-bending moment increments with and without jet exhaust plumes operating in order to evaluate the plume-induced separation effects on the current Space Shuttle Vehicle design. Of secondary importance was the evaluation of solid vs. gaseous plume simulations, recognizing that the solid plumes represent only a rough approximation because of the basic error in using a solid body to represent a gaseous boundary. Figures 4 and 5 present experimentally determined average plume shape variations with the viscous mixing parameter for various nozzle designs at free stream Mach numbers of 1.6 and 2.0. Figure 6 shows the variation of the average gaseous plume shape with the viscous mixing parameter at a given distance from the nozzle exit, with different nozzle designs illustrated. Also shown are the corresponding plume dimensions for the solid plume simulators. The remainder of the discussion of the test findings will be divided into basic propulsion effects and simulation problems. The basic data are presented in figures 7 through 27 as described in detail in the listing presented as table 8.

Basic Propulsion Effects

Nominal Power - $A/A^* = 8$

For the space shuttle launch configuration of the present tests, the plumes generated by the propulsion system cause significant effects on the

aerodynamic characteristics of the vehicle. The data show that the most significantly affected characteristics are the pitching moment, elevon control effectiveness, the axial force, and the orbiter wing loads. The changes in these characteristics from the power-off case are, of course, caused by the plume-induced flow separation (evidenced from the force and pitching-moment data and confirmed by fluorescent oil flow observations, not shown). Flow separation on the wing varies significantly with angle of attack for the Mach numbers tested. At near zero angle of attack there is only a small area of separation on the wing trailing edge ahead of the plume, extending no further forward than the elevon hinge line. As the angle of attack increases (either positively or negatively), the extent of flow separation increases until at 10° α the outboard portion of the wing, as described by a line from 50 percent of the leading edge and 80 percent of the trailing edge, was completely separated by the jet plume. The oil flow did not cover the rearward portion of the external tank and the SRM's so the extent of the flow separation there could not be visualized, but it is suspected that the separation was limited to a small aft region. As shown in figure 7, the plume-induced flow separation on the wing body causes a localized change in load distribution, resulting in a 10 to 20 percent decrease in normal force, creating a pitch-up moment that is maximum at angles of attack $-2 > \alpha > 4$ degrees. This pitch-up is accompanied by a large C_{m_0} shift. Flow separation on the wing causes a considerable reduction in root bending-moment which follows the same trends as the total vehicle moments (figure 7). Because the elevons are submerged

in the separated flow region, their effectiveness is drastically reduced, and for $M \geq 2.0$ control reversal existed as shown in figures 14 and 15.

Lateral-directional characteristics were not as severely affected by propulsion operation. Rudder control effectiveness was reduced by approximately 50 percent and aileron effectiveness was reduced to nearly zero, while lateral and directional stability was affected by 15 to 25 percent (figure 8). It is important to note that even though lateral-directional levels are reduced, the stability characteristics as a function of the angle of sideslip are more nearly linear than the longitudinal data. The longitudinal data have large shifts in the zero intercepts and the gradients change sign as a function of angle of attack.

Engine Isolation

The change in the aerodynamic characteristics as previously discussed, is caused by flow separation on the vehicle. By observing the data where the orbiter and the SRM plumes are operated separately and together, the effects caused by each propulsion system can be isolated. The data indicate that the SRM plumes have the largest effect on the aerodynamic characteristics. The orbiter plumes, by themselves, affect the data very little; however, their contribution is magnified when coupled with the SRM operation (figures 10 and 11).

Nozzle Design Sensitivity

The data presented in figure 7 illustrate the rather large effects on the vehicle aerodynamic characteristics (in particular, the pitching

moments) for moderate changes in the prototype nozzle design. The nominal data for this test were obtained for a prototype nozzle area ratio, $A/A^* = 8$, with variations on either side of this value; i.e., as shown in figure 7, for $A/A^* = 12$, and for an effectively lower value of A/A^* that was obtained by operating the model nozzle at about 30-percent higher than design chamber pressures. The data illustrate that larger expansion ratios (which yield smaller plumes) will reduce the jet plume effect on the vehicle aerodynamics. In fact, the data are sensitive to small changes in the plume shape in general, which is illustrated by comparing the data of figures 4 and 5, which show the plume shape variation with various nozzle designs, with the data of figures 7 and 9. Thus, it can be seen that variations in the nozzle design parameters can be used to reduce plume induced aerodynamic effects on the vehicle. This could be accomplished by increasing the nozzle area ratio, reducing the nozzle lip angle, or reducing the chamber pressure for the prototype propulsion system.

Simulation Effects

Simulation Validity

For these tests the prototype was simulated by matching plume shape using cold air as the simulant with tests conducted at $M = 1.6$ only. Plume sizes obtained during the present test did not necessarily simulate desired trajectory conditions. This occurred for two reasons. First, the plenum chamber pitot tubes gave erroneous readings. During a post test check, it was discovered that two SRM pitot tubes had broken off. It is also possible that plenum designs themselves could be deficient due to their small

size and sharp bends preceding them. This cannot be confirmed since a thorough pretest calibration of the plenums was not conducted. The second error was due to oxygen liquifaction and possible water vapor condensation. This is illustrated in pretest calibration data (reference 6). The calibration data indicate that oxygen liquified in the orbiter nozzle and outside the SRM nozzle in the plume. However, during the present test it is estimated that oxygen liquified in both orbiter and SRM nozzles because of the higher operating chamber pressure and approximately equal chamber temperatures. The oxygen liquifaction came as a surprise during the test due to an oversight in test design. However, without availability of a heated air supply nothing could be done to prevent this. The liquifaction tends to yield larger plumes for a given chamber pressure because heat is given up when oxygen liquifies, causing a jump in pressure. This oversized plume was confirmed when comparing quiescent plumes from the present test with analytical plumes, and has since been further confirmed in nozzle recalibrations conducted at the MSFC 14-Inch Trisonic Wind Tunnel (unpublished). Water vapor condensation could not be confirmed by a water content measurement. The only reason for suspecting water vapor condensation is because of the plume's visibility and because in the calibrations, plumes weren't visible even though oxygen liquifaction was present. However, since the present test was conducted at higher pressures, resulting in greater oxygen liquifaction, it is possible that the visibility was due to a combination of liquifaction and oxygen crystals present in the plume. Thus, information presently available is insufficient to determine

quantitatively the vapor state of the plume.

During the course of this test it was not realized that the broken pitot tubes or liquifaction existed. However, it was noted that some anomaly existed because P_c/P_e measured during the test did not match the analytical values. The assumption was then made that chamber pressure measurements were in error and that the exit pressure measurements were accurate. Based on this assumption, it was elected to adjust the chamber pressures to account for this deficiency by the ratio $(P_c/P_e)_{\text{analytical}} / (P_c/P_e)_{\text{test}}$. This procedure still left a deficiency in plume shape when plumes were calculated based on adjusted chamber pressure.

Using hindsight, it appears that at least part of this discrepancy is due to liquifaction/condensation effects. This discrepancy is not believed to have reduced the effectiveness with which the major test objectives were accomplished. This statement is based on the premise that, even though plume shape is an important simulation parameter, the test was designed to obtain sensitivities of plume effects on vehicles of this class where resulting data were not to be used for a specific vehicle design. Exact knowledge of the plume shapes tested is important to the analysis of the test results but ~~plume~~ shapes are not required to be of a specific size as long as the variations cover a range large enough to allow a sensitivity analysis. This could be serious for the test where prototype plume shape is required. Based on this experience, the following can be done to alleviate the problem; provide a heated air supply to eliminate oxygen liquifaction or, if heated air isn't available, calibrate

the nozzles and plenum at expected pressures and temperatures to obtain pressure compensation for liquifaction effects.

Effect of the Viscous Mixing Parameter

The attempts of this investigation to isolate the effects of the viscous mixing parameter, $(\rho U)_j / (\rho U)_\infty$ were unsuccessful because the plume size could not be held constant for varying values of $(\rho U)_j / (\rho U)_\infty$ and nozzle geometry became an unexpected variable. The reason for not being able to control the plume size (condensation effects) was previously discussed under "Simulation Validity". The data presented herein illustrate the fact that plume induced aerodynamic effects are, at least, a function of some parameter besides plume shape, but that the $(\rho U)_j / (\rho U)_\infty$ effect cannot be isolated from the present results (see figures 4, 5, and 6, and table 7). Thus, for the present investigation, plume effects were found to be a function of plume shape and nozzle geometry, neither of which were varied independently of the viscous mixing parameter. Even though no conclusions can presently be drawn concerning the $(\rho U)_j / (\rho U)_\infty$ effect, neither can it be ruled out as a significant factor.

Comparison of Solid Body and Gaseous Plumes

The data presented in figures 6 and 12 show that for the gaseous plumes tested a smaller solid body plume is required to produce similar results, particularly in the longitudinal data. The $M = 1.6$ solid body plume (designed to simulate plumes at $M = 1.6$ and trajectory pressure altitude for an earlier test and trajectory (ref. 1)) is of approximately

the same size as the nominal $M = 1.6$ gaseous plume (nominal conditions at $M = 1.6$ for the present test) yet looking at the pitching-moment curves, it can be seen that much larger effects are caused by the solid body. This effect was not as apparent for the yaw data (figures 8 and 12), including wing bending-moments, although the effects were not too large for the gaseous plumes either. The fact that the wing bending-moments were not affected differently indicates that, since the moment for the total vehicle was affected to a greater degree by the solid body plumes, local plume interference distribution must be considerably different. Even though the wing bending-moment characteristics are nearly the same for both solid and gaseous plumes, it is suspected that the wing load distribution is altered. It would be unreasonable to expect that all of the interference is confined to the EHOT and SRM since the wing is so close to these bodies. It is interesting to note that the $M = 1.4$ solid body simulators produced pitching-moment results very similar to those for the $M = 1.6$ gaseous plumes. However, it is believed that solid body simulators cannot be used for more than qualitative answers, and they will probably be limited to moderate angles of attack and to the higher Mach numbers where plume entrainment is small and doesn't affect the aft portion of the vehicle, i.e., at supersonic Mach numbers and altitude where considerable nozzle underexpansion exists. If they are to be used even qualitatively, then better understanding of the relationship between a solid and gaseous plume will be required. A development program would be required to accomplish this.

Effect of Plumes on Control Effectiveness

The remainder of the data presented in figures 13 through 27 are for the purpose of showing the effect of the plumes on elevon, aileron and rudder power and effectiveness. Figure 13 presents a comparison of control effectiveness with gaseous and solid SRM plumes. Plume effects with and without the OMS (orbital maneuvering system) pods are given in figure 14, and the effect of angle of attack on the lateral characteristics with and without the OMS is given in figures 15 and 16. Figures 17 through 20 show the effect of plumes on elevon, aileron and rudder power. The effect of plume size on elevon and rudder power is given in figures 21 and 22. The separate effects of orbiter and SRM plumes on elevon and rudder power is given in figures 23 and 24. The remaining figures, 25 through 27, show the effect of plumes on elevon, rudder, and aileron effectiveness. The effects of the plume simulation on the control power and effectiveness presented herein are given primarily to document the results obtained and will not be discussed in further detail.

CONCLUSIONS

1. For the space shuttle launch configuration of the present tests, the plumes generated by the propulsion system cause significant effects on the aerodynamic characteristics of the vehicle. The data show that the most significantly affected characteristics are the pitching moment, the elevator control effectiveness, the axial force, and the orbiter wing loads.
2. The SRM plumes have the largest effect on the aerodynamic characteristics. However, the orbiter plumes, when coupled with the SRM plumes also have a significant effect.
3. For the present configuration, at the test Mach number and altitude conditions, the plume-induced separation effects are very sensitive to small changes in the SRM plume shape.
4. Variations in the nozzle design parameters can be used to reduce plume induced aerodynamic effects (separation, aspiration, etc.) on the vehicle. These parameters include the nozzle area ratio, the nozzle lip angle, and chamber pressures of the prototype propulsion system.
5. Configuration design changes, such as a more rearward location of the SRM nozzles, should also produce smaller plume-induced effects.
6. The attempts to isolate the effects of the viscous mixing parameter were unsuccessful because the plume size could not be held constant for varying values of the parameter. Plume sizes obtained during the test were not as predicted, but this result will not adversely affect the use of present results because a range of plume sizes was

investigated.

7. A discussion of the factors of the present investigation that pertain to the validity of the proper simulation parameters indicates that further analysis is required.
8. A comparison of the aerodynamic results obtained from solid body plume simulators compared to gaseous simulation indicates that the solid body simulators caused larger aerodynamic effects for the same plume size than did the gaseous plume simulation.

REFERENCES

1. Brownson, Jack J.; Whitnah, A. Miles; Kassner, Donald L.; and Rampy, John: Aerodynamic Characteristics of an O40A Space Shuttle Launch Configuration With Simulated Rocket Plumes at Mach Numbers From 0.8 to 2.2. NASA TM X-62,126, September, 1972.
2. Penny, Morris M.; Baker, L. Ray Jr.; and Mc Canna, Richard W.: Prediction of the Space Shuttle Launch Vehicle Exhaust Plume Shapes for Several Trajectory Points. CR 115 728, 1972.
3. Smith, S. D.; and Ratliff, A. W.: Users Manual - Variable O/F Ratio Method of Characteristics Program For Nozzle and Plume Analysis. LMSC - HREC D162220 - IV, Lockheed Missile and Space Company, Huntsville, Ala., January, 1972.
4. McBride, Bonnie; and Gordon, S.: Preliminary Description of CEC, A Computer Program For Calculation of Chemical Equilibrium Compositions With Applications. Lewis Research Center, Cleveland, Ohio, May, 1961.
5. Herron, R. D.: Investigation of Jet Boundary Simulation Parameters For Underexpanded Jets in a Quiescent Atmosphere. AEDC TR-68-108, Arnold Engineering Development Center, Tullahoma, Tenn., September, 1968.
6. Baker, L. R.; Penny, M. M.; and Mc Canna, R. W.: Design and Calibration of Model Nozzles for Use Gasdynamic Simulation of the Space Shuttle Propulsion System Exhaust Plumes. LMSC - HREC - TR D306555, April 1, 1973.

TABLE 1. - Model Geometry
(MSC 040A)

Orbiter Body (Bl)

	Full scale, m, m ²	Model Scale, m, m ²
Length	33.401	0.6346
Max. width	5.1816	0.09845
Max. depth	6.0452	0.1149
Max. cross sectional area	28.4429	0.01027
Projected base area	27.4863	0.009923

Wing (Wl)

Total Data

Area		
Planform	293.1368	0.1058
Span (equivalent)	22.4028	0.4257
Aspect ratio	1.71212	1.71212
Taper ratio	0.14860	0.14860
Dihedral angle, degrees	7	7
Incidence angle, degrees	1.5	1.5
Aerodynamic twist, degrees	0	0
Sweep back angles, degrees		
Leading edge	60	60
Trailing edge	0	0
0.25 element line	52.42	52.42
0.5 element line	40.9	40.9
Chords:		
Root (wing sta. 0.0)	22.7838	0.4329
Tip (equivalent)	3.3858	0.06433
MAC	15.4813	0.2941
Fus. sta. of .25 MAC	26.8714	0.5106
B.L. of .25 MAC	4.2164	0.0801
Airfoil section		
Root	NACA 0008-64	0008-64
Tip	NACA 0008-64	0008-64

TABLE 1. - Continued.

Exposed data		
Area	186.7356	0.06741
Span, (equivalent)	17.2212	0.3272
Aspect ratio	1.58818	1.58818
Taper ratio	0.18501	0.18501
Chords		
Root	18.3007	0.3477
Tip	3.3858	0.06435
MAC	12.5527	0.2385
Fus. sta. of .25 MAC	29.0661	0.5523
B.L. of .25 MAC	5.9090	0.1123
Elevon (W1) (each)		
Area	21.1509	0.007635
Span (equivalent)	7.0612	0.1342
Inb'd equivalent chord	2.9972	0.05695
Outb'd equivalent chord	2.9972	0.05695
Ratio movable surface chord/total surface chord		
At inb'd equiv. chord	.166	.166
At outb'd equiv. chord	.516	.516
Sweep back angles, degrees		
Trailing edge	0°	0°
Hingeline	0°	0°
Vertical tail (V2)		
Leading edge sweepback, deg	45	45
Airfoil section		
Root	NACA 0012-64	0012-64
Tip	NACA 0012-64	0012-64
Exposed data		
Area	45.0562	0.01626
Span, (equivalent)	9.3769	0.1782
Aspect ratio	1.95	1.95
Taper ratio	0.3137	0.3137
Chords		
Root	7.3152	0.1390
Tip	2.2949	0.04361
MAC	5.2421	0.09959

TABLE 1. - Concluded.

Fus. sta. of .25 MAC	37.3136	0.7090
W.P. of .25 MAC	16.5720	0.3149
B.L. of .25 MAC	0	0
Rudder (V2)		
Area	18.4585	0.006663
Span (equivalent)	8.7630	0.1665
Inb'd equivalent chord (WL = 12.700)	2.921	0.0555
Outb'd equivalent chord (WL = 21.463)	1.016	0.01930
Ratio movable surface chord/total surface chord		
At inb'd equiv. chord	0.4	0.4
At outb'd equiv. chord	0.4	0.4
Sweep back angles, degrees		
Trailing edge	25	25
Hingeline	35	35
Body of revolution (EHOT)		
Length	48.4566	0.9207
Max. width (dia)	8.2885	0.1575
Fineness ratio	5.846	5.846
Area, max. cross- sectional	53.9558	0.01948
Body of revolution (SRM) (Each)		
Length	39.3835	0.7483
Max. width (dia)	3.9624	0.07529
Fineness ratio	9.939	9.939
Area, max. cross- sectional	12.3313	0.004452

ORBITER NOZZLES

M = 1.6 Nozzle

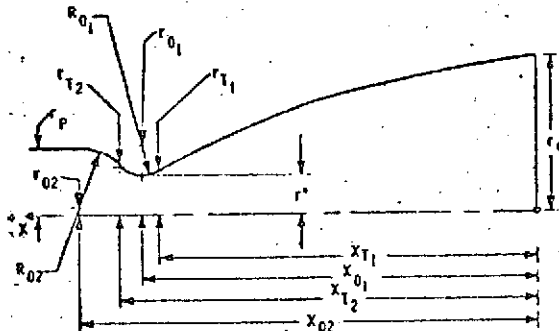

	meters	(inches)		meters	(inches)
r_{01}	0.02189	(0.8619)	r_{T2}	0.0591	(2.3274)
X_{T2}	0.0536	(2.1103)	r_{T1}	0.0057	(0.2267)
r_{T2}	0.0061	(0.2383)	X_{02}	0.0045	(0.1789)
r_{02}	0.0044	(0.1747)	r_{01}	0.0010	(0.0408)
X_{01}	0.0560	(2.2038)	r_{02}	0.0089	(0.3139)
r_{01}	0.0098	(0.3862)	r_P	0.0090	(0.3547)
r^*	0.0094	(0.3115)			

M = 2.0 Nozzle

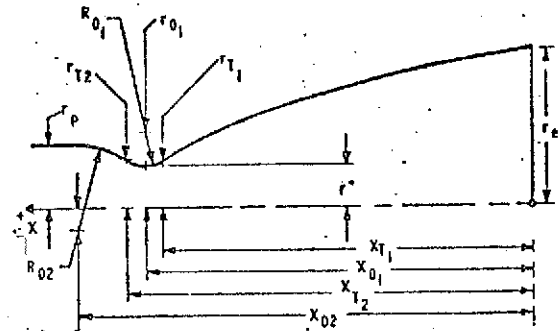

	meters	(inches)		meters	(inches)
r_{01}	0.02189	(0.8619)	X_{T2}	0.0579	(2.2814)
X_{T2}	0.0527	(2.0740)	r_{T2}	0.0068	(0.2630)
r_{T2}	0.0066	(0.2610)	X_{02}	0.0049	(0.1958)
r_{02}	0.0048	(0.1900)	r_{01}	0.0031	(0.1232)
X_{01}	0.0552	(2.1723)	r_{02}	0.0121	(0.4779)
r_{01}	0.0107	(0.4216)	r_P	0.0090	(0.3547)
r^*	0.0059	(0.2336)			

NOZZLE CONTOUR DATA

X/r_0	R/r_0	X/r_0	R/r_0	X/r_0	R/r_0
0.0340	0.9954	1.0543	0.8098	1.8349	0.5751
0.1043	0.9856	1.0946	0.8001	1.8987	0.5504
0.1823	0.9744	1.1470	0.7872	1.9715	0.5207
0.2685	0.9614	1.2143	0.7700	2.0326	0.4946
0.3131	0.9544	1.2518	0.7603	2.0775	0.4745
0.4134	0.9380	1.2933	0.7492	2.1435	0.4438
0.5096	0.9216	1.3397	0.7364	2.2264	0.4028
0.5713	0.9104	1.3908	0.7219	2.2462	0.3926
0.6508	0.8957	1.4564	0.7026	2.3097	0.3586
0.6951	0.8871	1.5187	0.6837	2.3427	0.3401
0.7444	0.8774	1.5595	0.6708	2.3598	0.3302
0.7993	0.8662	1.6111	0.6543	2.4063	0.3028
0.8601	0.8535	1.6724	0.6337	2.4287	0.2891
0.9275	0.8388	1.7483	0.6071	2.4490	0.2765
0.9919	0.8243	1.7934	0.5907		

— End of M = 2.0 nozzle
 — End of M = 1.6 nozzle

Table 2. Model Nozzle Geometry

SRM NOZZLES

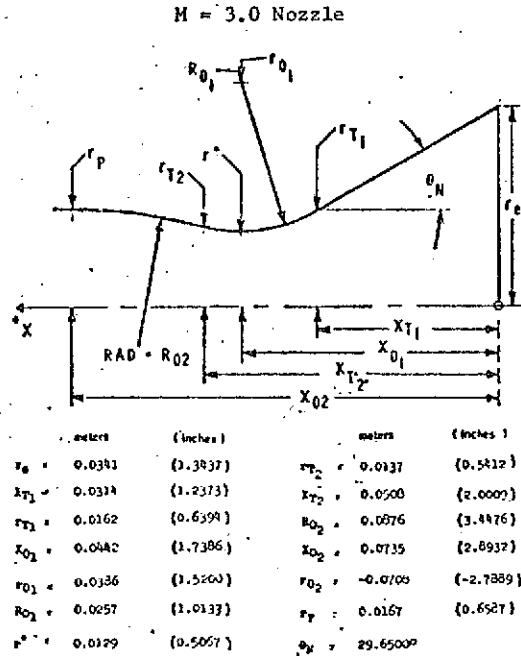
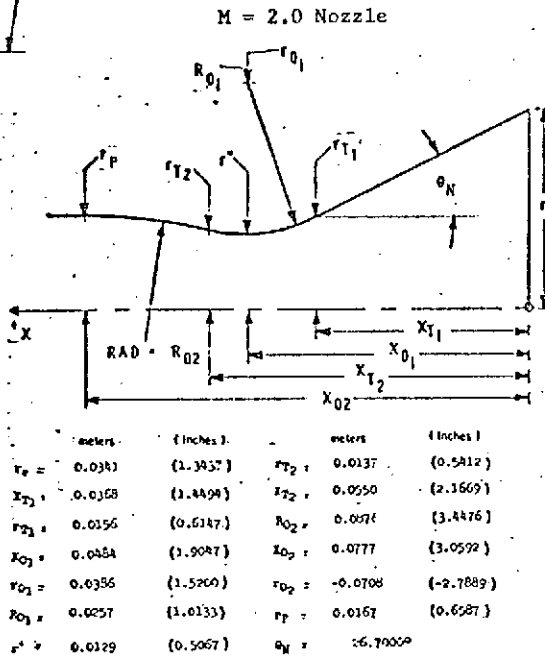
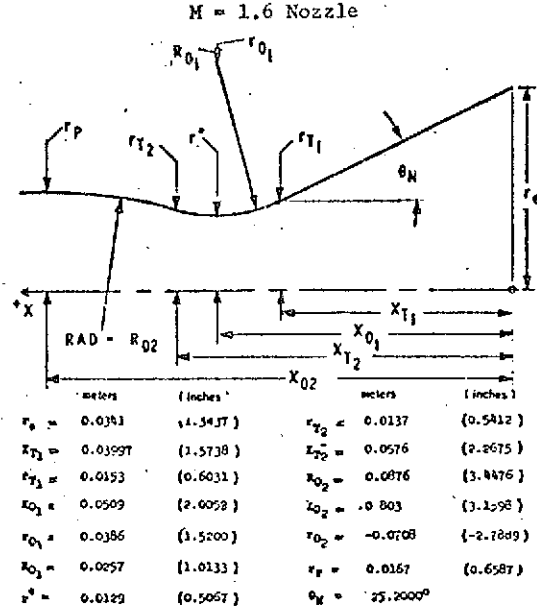
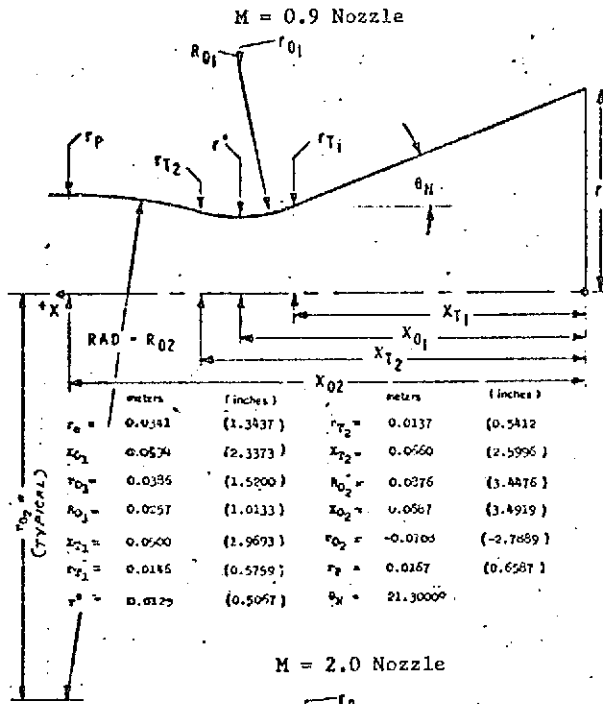

Table 2 (concluded). MODEL NOZZLE GEOMETRY

TABLE 3. - SRM SOLID PLUME SHAPES
(from ref. 2)

Nozzle - 1.4
 $P_c = 526.75 \times 10^4 \text{ N/m}^2$
 $P_\infty = 147.95 \times 10^2 \text{ N/m}^2$

Nozzle - 1.6
 $P_c = 513.66 \times 10^4 \text{ N/m}^2$
 $P_\infty = 96.239 \times 10^2 \text{ N/m}^2$

x/r_e	\bar{r}/r_e
0	1.00
0.164	1.149
0.537	1.448
1.052	1.784
1.776	2.172
2.545	2.500
3.269	2.746
4.545	3.067
6.000	3.291
6.791	3.351
7.612	3.381
8.955	3.381

x/r_e	\bar{r}/r_e
0	1.00
0.522	1.507
1.239	2.052
2.119	2.575
2.784	2.896
3.552	3.216
4.418	3.507
5.388	3.761
7.567	4.127
8.955	4.231

TABLE 4. - PROTOTYPE NOZZLE-MOTOR CHARACTERISTICS

SRM		Orbiter	
P_c (See figure below)			
A/A^* = 8.0	Area Ratio,	$\epsilon = 79.436:1$	
$\theta_{lip} = 17.5$ deg	$P_c = 200$ Atmos.	$\theta_{lip} = 7.87$ deg	
$D_{ex} = 3.5921$ m	$D_t = 0.2585$ m	$D_{ex} = 2.3043$ m	
$D_T = 1.27$ m			

Propellant Composition

AP	69.0	} By Weight
AZ	15.0	
PBAN	9.6	
Binder Materials	6.4%	

Propellant Composition

O/F = 6.0	Oxidizer	$-O_2(L)$
	Fuel	$-H_2(L)$

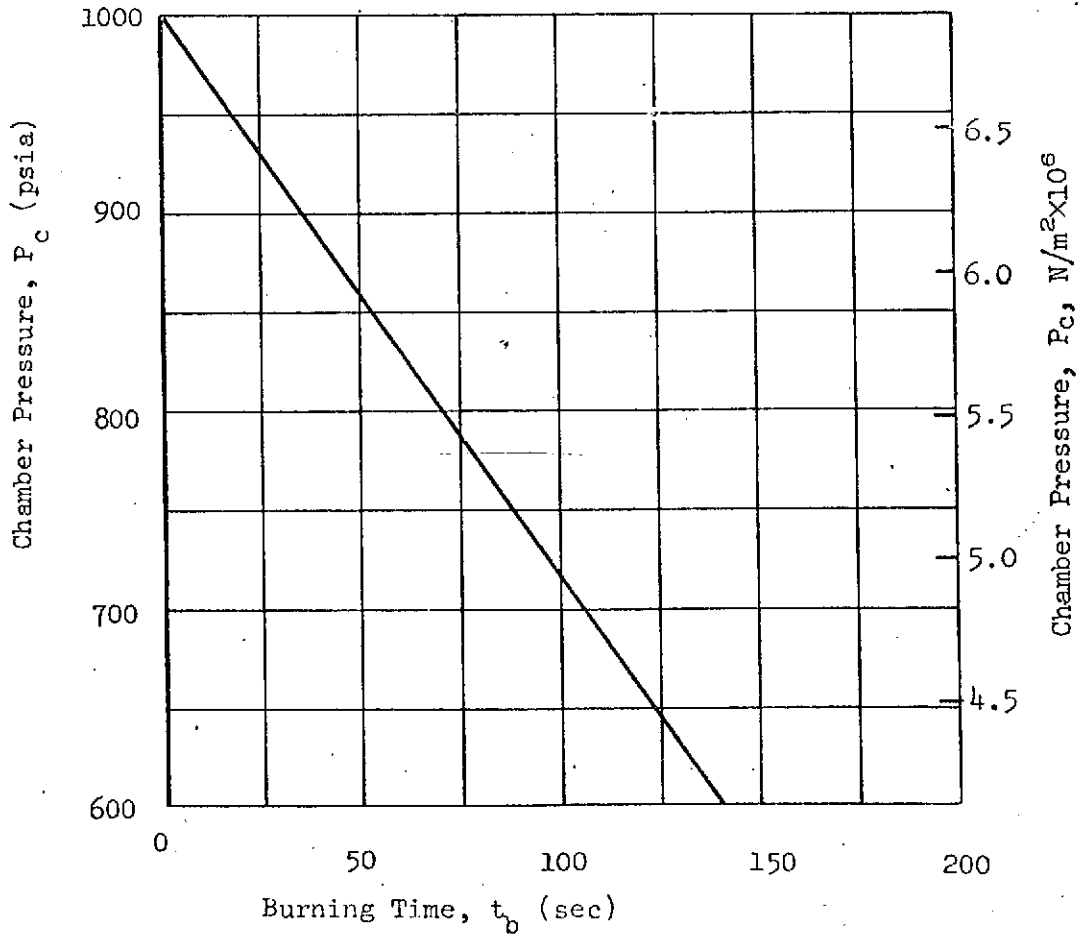

TABLE 5. - LAUNCH TRAJECTORY CONDITIONS

M_{∞}	t (sec)	Altitude, h (m)	P (N/m^2)
0.9	58	7,620	38,687
1.2	73	11,278	23,461
1.6	89	16,459	9,624
2.0	101	21,031	4,788
2.2	107	24,079	2,777
3.0	117	30,785	1,053

TABLE 6. - Experimental SRM Plume Shapes and Test Conditions

Nozzle - 1.6, $M_\infty = 1.6$
 Run 2 Corr 570
 SRM & Orbiter Engine Operating
SRM DATA

$$(P_c/P_t)_{set} = 132. (P_c/P_t)_{cal} = 154.$$

$$(\rho U)_j = 5.0179 \times 10^3 \quad (\rho U)_\infty = 4.1512 \times 10^2$$

$$(\rho U)_j / (\rho U)_\infty = 12.1$$

x/r_e	r_u/r_e	r_l/r_e	\bar{r}/r_e
.37	1.31	NA	NA
.74	1.58	NA	NA
1.12	1.85	NA	NA
1.49	2.08	NA	NA
1.86	2.26	NA	NA
2.23	2.50	NA	NA
2.61	2.62	2.77	2.70
2.98	2.80	3.01	2.91
3.35	2.92	3.12	3.02
3.72	3.07	3.30	3.19
4.47	3.27	3.54	3.41
5.21	3.45	3.75	3.60
5.96	3.63	3.93	3.78
6.67	3.75	4.11	3.93
7.44	3.87	4.26	4.07
8.93	3.96	4.55	4.26
10.42	3.87	NA	NA

Nozzle - 1.6, $M_\infty = 1.6$
 Run 9 Corr 739
 SRM & Orbiter Engine Operating
SRM DATA

$$(P_c/P_t)_{set} = 77.6 (P_c/P_t)_{cal} = 90.7$$

$$(\rho U)_j = 1.075 \times 10^4 \quad (\rho U)_\infty = 1.1108 \times 10^3$$

$$(\rho U)_j / (\rho U)_\infty = 9.69$$

x/r_e	r_u/r_e	r_l/r_e	\bar{r}/r_e
.37	1.28	NA	NA
.74	1.49	NA	NA
1.12	1.70	NA	NA
1.49	1.87	NA	NA
1.86	2.02	NA	NA
2.23	2.14	NA	NA
2.61	2.23	NA	NA
2.98	2.35	NA	NA
3.35	2.41	2.89	2.65
3.72	2.47	3.01	2.74
4.47	2.62	3.18	2.90
5.21	2.68	3.36	3.02
5.96	2.74	3.51	3.13
6.67	2.80	3.66	3.23
7.44	2.89	3.81	3.35
8.93	2.89	3.98	3.44
10.42	2.83	4.08	3.46

TABLE 6. - Continued.

Nozzle - 1.6, $M_\infty = 1.6$
 Run 14 Corr 812
 SRM & Orbiter Engine Operating
SRM DATA

$$(P_c/P_t)_{set} = 177 \quad (P_c/P_t)_{cal} = 206$$

$$(\rho U)_j = 1.1937 \times 10^4 \quad (\rho U)_\infty = 8.5754 \times 10^2$$

$$(\rho U)_j / (\rho U)_\infty = 13.92$$

x/r_e	r_u/r_e	r_l/r_e	\bar{r}/r_e
.37	1.28	NA	NA
.74	1.61	NA	NA
1.12	1.85	NA	NA
1.49	2.14	NA	NA
1.86	2.32	NA	NA
2.23	2.50	2.92	2.71
2.61	2.65	3.18	2.92
2.98	2.83	3.36	3.10
3.35	2.95	3.54	3.25
3.72	3.07	3.72	3.40
4.47	3.24	3.99	3.62
5.21	3.42	4.26	3.84
5.96	3.60	NA	NA
6.67	3.72	NA	NA
7.44	3.84	NA	NA
8.93	4.08	NA	NA
10.42	4.26	NA	NA

Nozzle 1.6, $M_\infty = 1.6$
 Run 13 Corr 798
 SRM Engine Operating
SRM DATA

$$(P_c/P_t)_{set} = 137 \quad (P_c/P_t)_{cal} = 160$$

$$(\rho U)_j = 1.4220 \times 10^4 \quad (\rho U)_\infty = 1.1348 \times 10^3$$

$$(\rho U)_j / (\rho U)_\infty = 12.53$$

x/r_e	r_e/r_e	r_l/r_e	\bar{r}/r_e
.37	1.34	NA	NA
.74	1.58	NA	NA
1.12	1.85	NA	NA
1.49	2.05	NA	NA
1.86	2.23	NA	NA
2.23	2.41	2.83	2.62
2.61	2.59	3.01	2.80
2.98	2.77	3.18	2.98
3.35	2.92	3.30	3.11
3.72	3.07	3.48	3.28
4.47	3.27	3.75	3.51
5.21	3.48	3.99	3.74
5.96	3.66	4.20	3.93
6.67	3.81	4.40	4.11
7.44	3.93	4.58	4.26
8.93	4.17	4.88	4.53
10.42	4.26	NA	NA

TABLE 6. - Continued.

Nozzle 0.9, $M_\infty = 1.6$
 Run 75 Corr 1642
 SRM Engine Operating
SRM DATA

$$(P_c/P_t)_{\text{set}} = 141 \quad (P_c/P_t)_{\text{cal}} = 165$$

$$(\rho U)_j = 1.5274 \times 10^4 \quad (\rho U)_\infty = 1.2545 \times 10^3$$

$$(\rho U)_j / (\rho U)_\infty = 12.2$$

x/r_e	r_u/r_e	r_l/r_e	\bar{r}/r_e
.74	1.36	NA	NA
1.49	1.84	NA	NA
2.23	2.20	NA	NA
2.98	2.56	NA	NA
3.35	2.68	2.68	2.68
3.72	2.80	2.74	2.77
4.47	3.03	3.15	3.09
5.21	3.33	3.33	3.33
5.76	3.45	3.63	3.54
6.67	3.57	3.81	3.69
7.44	3.75	3.99	3.87
8.93	3.93	4.11	4.02
10.42	3.99	4.34	4.17

Nozzle 0.9, $M_\infty = 1.6$
 Run 69 Corr 1587
 SRM Engines Operating
SRM DATA

$$(P_c/P_t)_{\text{set}} = 96.4 \quad (P_c/P_t)_{\text{cal}} = 113$$

$$(\rho U)_j = 1.5752 \times 10^4 \quad (\rho U)_\infty = 1.5465 \times 10^3$$

$$(\rho U)_j / (\rho U)_\infty = 10.2$$

x/r_e	r_u/r_e	r_l/r_e	\bar{r}/r_e
.74	1.31	NA	NA
1.49	1.73	NA	NA
2.23	2.02	NA	NA
2.98	2.32	NA	NA
3.35	2.44	2.32	2.38
3.72	2.56	2.50	2.53
4.47	2.68	2.92	2.80
5.21	2.92	3.03	2.97
5.96	2.98	3.15	3.07
6.67	3.03	3.39	3.21
7.44	3.09	3.51	3.30
8.93	NA	NA	NA
10.42	NA	NA	NA

TABLE 6. - Continued.

Nozzle -3.0, $M_\infty = 1.6$
 Run 80 Corr 1686
 SRM Engine Operating
SRM DATA

$$(P_c/P_t)_{set} = 156 \quad (P_c/P_t)_{cal} = 182$$

$$(\rho U)_j = 1.0222 \times 10^4 \quad (\rho U)_\infty = 7.4789 \times 10^2$$

$$(\rho U)_j / (\rho U)_\infty = 13.67$$

x/r_e r_u/r_e r_l/r_e \bar{r}/r_e

.37	1.25	NA	NA
.74	1.64	NA	NA
1.12	1.93	NA	NA
1.49	2.20	NA	NA
1.86	2.49	NA	NA
2.23	2.65	2.89	2.77
2.61	2.89	3.12	3.01
2.98	3.07	3.27	3.17
3.35	3.24	3.45	3.35
3.72	3.42	3.66	3.54
4.47	3.72	3.96	3.84
5.21	3.90	4.23	4.07
5.96	4.11	4.32	4.22
6.67	4.29	4.52	4.41
7.44	4.40	4.67	4.54
8.93	4.61	4.97	4.79
10.42	4.72	5.21	4.97

Nozzle -3.0, $M_\infty = 1.6$
 Run 78 Corr 1666
 SRM Engine Operating
SRM DATA

$$(P_c/P_t)_{set} = 189 \quad (P_c/P_t)_{cal} = 221$$

$$(\rho U)_j = 1.1625 \times 10^4 \quad (\rho U)_\infty = 7.8093 \times 10^2$$

$$(\rho U)_j / (\rho U)_\infty = 14.89$$

x/r_e r_u/r_e r_l/r_e \bar{r}/r_e

.37	1.34	NA	NA
.74	1.64	NA	NA
1.12	1.87	NA	NA
1.49	2.20	NA	NA
1.86	2.47	2.77	2.62
2.23	2.71	2.95	2.83
2.61	2.95	3.18	3.07
2.98	3.15	3.36	3.26
3.35	3.30	3.54	3.42
3.72	3.45	3.75	3.60
4.47	3.78	4.14	3.96
5.21	4.08	NA	NA
5.96	4.29	NA	NA
6.67	4.46	NA	NA
7.44	4.67	NA	NA
8.93	4.97	NA	NA
10.42	5.24	NA	NA

TABLE 6. - Continued.

Nozzle -3.0, $M_\infty = 1.6$
 Run 79 Corr 1676
 SRM Engine Operating
SRM DATA

$$(P_c/P_t)_{\text{set}} = 225 \quad (P_c/P_t)_{\text{cal}} = 262$$

$$(\rho U)_j = 1.2229 \times 10^4 \quad (\rho U)_\infty = 7.6273 \times 10^2$$

$$(\rho U)_j / (\rho U)_\infty = 16.03$$

x/r_e	r_u/r_e	r_l/r_e	\bar{r}/r_e
.37	1.40	NA	NA
.74	1.76	NA	NA
1.12	2.08	NA	NA
1.49	2.35	NA	NA
1.86	2.65	2.80	2.72
2.23	2.95	3.07	3.01
2.61	3.18	3.30	3.24
2.98	3.39	3.54	3.47
3.35	3.57	3.75	3.66
3.72	NA	NA	NA
4.47	4.11	NA	NA
5.21	4.40	NA	NA
5.96	4.70	NA	NA
6.67	4.91	NA	NA
7.44	5.15	NA	NA
8.93	5.45	NA	NA
10.42	5.62	NA	NA

TABLE 6. - Continued.

Nozzle 2.0, $M_\infty = 2.0$
 Run 32 Corr 1090
 SRM & Orbiter Engine Operating
SRM DATA

$$(P_c/P_t)_{set} = 141 \quad (P_c/P_t)_{cal} = 165$$

$$(\rho U)_j = 1.1396 \times 10^4 \quad (\rho U)_\infty = 7.8524 \times 10^2$$

$$(\rho U)_j / (\rho U)_\infty = 14.5$$

x/r_e	r_u/r_e	r_l/r_e	\bar{r}/r_e
.37	1.28	NA	NA
.74	1.58	NA	NA
1.12	1.90	NA	NA
1.49	2.20	NA	NA
1.86	2.44	2.86	2.65
2.23	2.65	3.10	2.88
2.61	2.83	3.30	3.06
2.98	2.98	3.48	3.23
3.35	3.12	3.69	3.40
3.72	3.27	3.90	3.59
4.47	3.51	4.20	3.86
5.21	3.69	4.55	4.12
5.96	3.87	4.76	4.31
6.67	3.99	NA	NA
7.44	4.11	NA	NA
8.93	4.37	NA	NA
10.42	4.52	NA	NA

Nozzle 2.0, $M_\infty = 2.0$
 Run 37 Corr 1156
 SRM & Orbiter Engine Operating
SRM DATA

$$(P_c/P_t)_{set} = 71 \quad (P_c/P_t)_{cal} = 83$$

$$(\rho U)_j = 8.1396 \times 10^3 \quad (\rho U)_\infty = 7.7566 \times 10^2$$

$$(\rho U)_j / (\rho U)_\infty = 10.5$$

x/r_e	r_u/r_e	r_l/r_e	\bar{r}/r_e
.37	1.19	NA	NA
.74	1.43	NA	NA
1.12	1.64	NA	NA
1.49	1.85	NA	NA
1.86	1.99	NA	NA
2.23	2.14	NA	NA
2.61	2.29	2.98	2.64
2.98	2.47	3.07	2.76
3.35	2.53	3.24	2.89
3.72	2.62	3.39	3.00
4.47	2.80	3.66	3.23
5.21	2.98	3.87	3.43
5.96	3.07	4.11	3.59
6.67	3.18	4.26	3.72
7.44	3.27	4.37	3.82
8.93	3.45	4.61	4.03
10.42	3.60	NA	NA

TABLE 6. - Concluded.

Nozzle 2.0, $M_\infty = 2.0$
 Run 38 Corr 1166
 SRM & Orbiter Engine Operating
SRM DATA

$$(P_c/P_t)_{\text{set}} = 181 \quad (P_c/P_t)_{\text{cal}} = 211$$

$$(\rho U)_j = 9.8154 \times 10^3 \quad (\rho U)_\infty = 5.9372 \times 10^2$$

$$(\rho U)_j / (\rho U)_\infty = 16.5$$

x/r_e	r_u/r_e	r_l/r_e	\bar{r}/r_e
.37	1.34	NA	NA
.74	1.64	NA	NA
1.12	1.93	NA	NA
1.49	2.20	2.62	2.41
1.86	2.50	2.83	2.67
2.23	2.74	3.10	2.92
2.61	2.98	3.33	3.16
2.98	3.12	3.51	3.31
3.35	3.27	3.72	3.50
3.72	3.42	3.90	3.66
4.47	3.69	4.26	3.98
5.21	3.90	4.55	4.23
5.96	4.05	4.82	4.44
6.67	4.20	5.09	4.65
7.44	4.32	5.36	4.84
8.93	4.55	NA	NA
10.42	4.67	NA	NA

Nozzle 2.0, $M_\infty = 2.0$
 Run 43 Corr 1210
 SRM Engine Operating
SRM DATA

$$(P_c/P_t)_{\text{set}} = 127 \quad (P_c/P_t)_{\text{cal}} = 149$$

$$(\rho U)_j = 1.1683 \times 10^4 \quad (\rho U)_\infty = 8.4269 \times 10^2$$

$$(\rho U)_j / (\rho U)_\infty = 13.9$$

x/r_e	r_u/r_e	r_l/r_e	\bar{r}/r_e
.37	1.31	NA	NA
.74	1.61	NA	NA
1.12	1.87	NA	NA
1.49	2.11	NA	NA
1.86	2.35	NA	NA
2.23	2.53	3.04	2.78
2.61	2.74	3.27	3.00
2.98	2.92	3.48	3.20
3.35	3.07	3.66	3.37
3.72	3.27	3.84	3.55
4.47	3.54	4.14	3.84
5.21	3.87	4.47	4.17
5.96	4.11	4.73	4.42
6.67	4.37	4.94	4.66
7.44	4.55	5.15	4.85
8.93	4.82	NA	NA
10.42	4.94	NA	NA

TABLE 7 - NOZZLE TEST CONDITIONS

Run	Corr.	M _∞	M _{nozzle}	$(\rho U)_1 / (\rho U)_\infty$	P _{cset}	ORBITER ¹				SRM ²		
						P _{c1} /P _{t∞}	P _{c2} /P _{t∞}	P _{c3} /P _{t∞}	Design P _c /P _{t∞}	P _{c4} /P _{t∞}	P _{c5} /P _{t∞}	Design P _c /P _{t∞}
2	510	1.6	1.6	12.1	NOM.	151.4	147.7	148.1	118.0	147.6	154.2	155.9
3	598	↓	↓	12.41	NOM.	110.4	107.8	108.8	118.0	150.6	156.6	155.9
9	739	↓	↓	9.67	A/A*=12	120.5	117.8	118.0	118.0	86.9	90.67	91.03
12	781	↓	↓	--	NOM. ORB Only	113.5	111.0	111.1	118.0	--	--	--
13	798	↓	↓	12.53	NOM. SRM Only	--	--	--	--	153.8	159.8	155.9
14	812	↓	↓	13.92	1.3 P _c NOM.	149.4	146.0	146.3	153.4	198.1	206.4	202.7
32	1090	2.0	2.0	14.50	NOM.	98.37	95.33	97.16	101.2	158.0	164.8	165.6
37	1156	↓	↓	10.53	A/A*=12	103.6	100.9	102.9	101.2	80.19	83.28	84.66
38	1166	↓	↓	16.09	1.3 P _c	131.8	123.2	130.7	131.6	203.3	211.1	215.3
42	1200	↓	↓	NA	NOM. ORB Only	96.46	93.80	95.31	101.2	--	--	--
43	1210	↓	↓	13.83	NOM. SRM Only	--	--	--	--	143.0	143.8	165.6
44	1225	2.2	↓	16.31	NOM.	170.1	165.6	167.2	169.5	176.6	188.4	185.8
45	1242	2.0	↓	14.43	NOM. SRM Only	--	--	--	--	158.4	165.5	163.6
47	1269	2.2	↓	16.51	NOM.	162.2	158.1	160.4	169.5	182.7	190.2	185.8

¹ P_{c1,2,3} = P_{c1,2,3} Tunnel Output/0.931

² P_{c4,5} = P_{c4,5} Tunnel Output/0.855

(Continued)

54

TABLE 7 - NOZZLE TEST CONDITIONS (Concluded)

Run	Corr.	M_∞	M_{nozzle}	$(\rho U)_j / (\rho U)_\infty$	$P_{c\text{set}}$	ORBITER ¹				SRM ²		
						P_{c1} / P_{t_∞}	P_{c2} / P_{t_∞}	P_{c3} / P_{t_∞}	Design P_c / P_{t_∞}	P_{c4} / P_{t_∞}	P_{c5} / P_{t_∞}	Design P_c / P_{t_∞}
78	1666	1.6	3.0	14.89	NOM. SRM Only	--	--	--	--	213.6	221.1	228.2
79	1676		↓	16.03	1.2 P_c , SRM Only	--	--	--	--	253.8	262.4	273.8
80	1686		↓	13.67	.8 P_c , SRM Only	--	--	--	--	175.5	182.0	182.5
75	1642		0.9	12.20	1.1 P_c , SRM Only	--	--	--	--	160.3	165.1	162.8
69	1587		↓	10.17	SRM Only	--	--	--	--	109.1	112.8	
72	1612		↓	10.76	SRM Only	--	--	--	--	170.1	124.1	--

TABLE 8.

TEST: ARC 97-616		DATA SET/RUN NUMBER COLLATION SUMMARY							DATE:								
DATA SET IDENTIFIER	CONFIGURATION PLUME SHAPE	SCHD.		PARAMETERS/VALUES				NO. OF RUNS	MACH NUMBERS (OR ALTERNATE INDEPENDENT VARIABLE)								
		α	β	δ_e	δ_a	δ_r	PLUMES		1.6	2.0	2.2						
RB001	O ₂ To S ₁	A	O	O	O	O	ALL		2	31	44						
02		O	B				ALL		3	34	47						
03		A	O				SRM		13	45							
04		O	B				SRM		11	46							
05	NOMINAL	A	O				ORB		12	42							
06	NOMINAL	O	B				ORB		10	41							
07	NOMINAL ORB SRM A/A [*] =12	A	O				ALL		8	37							
08		O	B						9	36							
09	NOMINAL P _c /P _t =1.3	A	O						14	38							
10		O	B						15	39							
11	NOMINAL SRM A/A [*] =8	A	O	10	0	10			16	48	58						
12		O	B						17	49	59						
13		A	O				SRM		21	57							
14		O	B				SRM		20	54							
15	NOMINAL	A	O				ORB		22	56							
16	NOMINAL	O	B				ORB		28	55							
17	ORB NOMINAL SRM A/A [*] =12	A	O				ALL		18	51							
18		O	B				ALL		19	50							

TEST RUN NUMBERS

48

1 7 13 19 25 31 37 43 49 55 61 67 75 76

α OR β
SCHEDULES

COEFFICIENTS
 $\alpha(A) : -4^\circ \rightarrow 10^\circ$ in 2 increments
 $\beta(B) : -4^\circ \rightarrow 6^\circ$ in 2 increments

IDVAR (1) IDVAR (2) NDV

TABLE 8. - Continued.

TEST: ARC 97-616		DATA SET/RUN NUMBER COLLATION SUMMARY							DATE :												
DATA SET IDENTIFIER	CONFIGURATION	SCHO.		PARAMETERS/VALUES				NO. OF RUNS	MACH NUMBERS (OR ALTERNATE INDEPENDENT VARIABLE)												
		α	β	δ_e	δ_a	δ_r	PLURAL ²⁵		1.6	2.0	2.2										
RBJ019	O.T.S. PLUMB SHAPE NOMINAL Pc/Pt = 1.3	A	0	10	0	10	ALL		26	52											
20	↓	0	B	10	0	10	ALL		27	53											
21	NOMINAL SRM A/A ² = 8	A	0	-10	0	10			29	64											
22	↓	A	0	0	10	0				61											
23	↓	0	B						30	60											
24	ORB NOMINAL SRM A/A ² = 12	A	0	↓	↓	↓				62											
25	NOMINAL SRM A/A ² = 8	-5	B	0	0	0				33											
26	↓	5	B							35											
27	NOMINAL SRM A/A ² = 8	A	0						4												
28	OMS	-5	B						5												
29	OMS	0	B						6												
30	OMS	5	B						7												
31	M = .9 No. 2 Pc/Pt = .82	A	0				SRM		74												
32	M = .9 No. 2 Pc/Pt = 1.1	A	0						75												
33	M = 3.0 No. 2 Pc/Pt = No. 1	A	0						78												
34	M = 3.0 No. 2 Pc/Pt = 1.2	A	0						79												
35	M = 3.0 No. 2 Pc/Pt = 0.8	A	0	↓	↓	↓	↓		80												
RBJ542	O.T.S. M = 1.6 SOLID SRM	0	B	0	0	0			592												

TEST RUN NUMBERS:

49

1 7 13 19 25 31 37 43 49 55 61 67 75 76

COEFFICIENTS

IDVAR (1) IDVAR (2) NDV

α OR β _____

SCHEDULES _____

TABLE 8. - Concluded.

TEST: ARC 97-616		DATA SET/RUN NUMBER COLLATION SUMMARY										DATE:					
DATA SET IDENTIFIER	CONFIGURATION <i>PLUME SHAPE</i>	SCHD.		PARAMETERS/VALUES				NO. OF RUNS	MACH NUMBERS (OR ALTERNATE INDEPENDENT VARIABLE)								
		α	β	S_e	S_a	S_r	P_{max}		1.6	2.0	2.2						
RB7501	<i>O.T.S.</i>	<i>No PLUME</i>	A	0	0	0	0	0	502	531	544						
502			0	B					503	534	547						
524			-5	B													
525			5	B	↓	↓	↓			533							
511			A	0	10	0	10			535							
512			0	B	10	0	10		516	548	558						
521			A	0	-10	0	10		517	549	559						
522			A	0	0	10	0		529	564							
523			0	B	0	10	0			561							
527	<i>O.T.S.</i>	<i>OMS No PLUME</i>	A	0	0	0	0		530	560							
528			-5	B					504								
529			0	B					505								
530			5	B				↓	506								
536	<i>O.T.S.</i>	<i>M=1.4 SOLID SRM</i>	A	0					507								
538			0	B	↓	↓	↓		586								
539			A	0	10	0	10		587								
540			0	B	10	0	10		588								
541		<i>M=1.6 SOLID SRM</i>	A	0	0	0	0		589								
									591								

TEST RUN NUMBERS

50

1	7	13	19	25	31	37	43	49	55	61	67	75	76	
COEFFICIENTS														
α OR β SCHEDULES												IDVAR (1)	IDVAR (2)	NDV

Notes:

1. Positive directions of force coefficients, moment coefficients, and angles are indicated by arrow
2. For clarity, origins of wind and stability axes have been displaced from the center of gravity

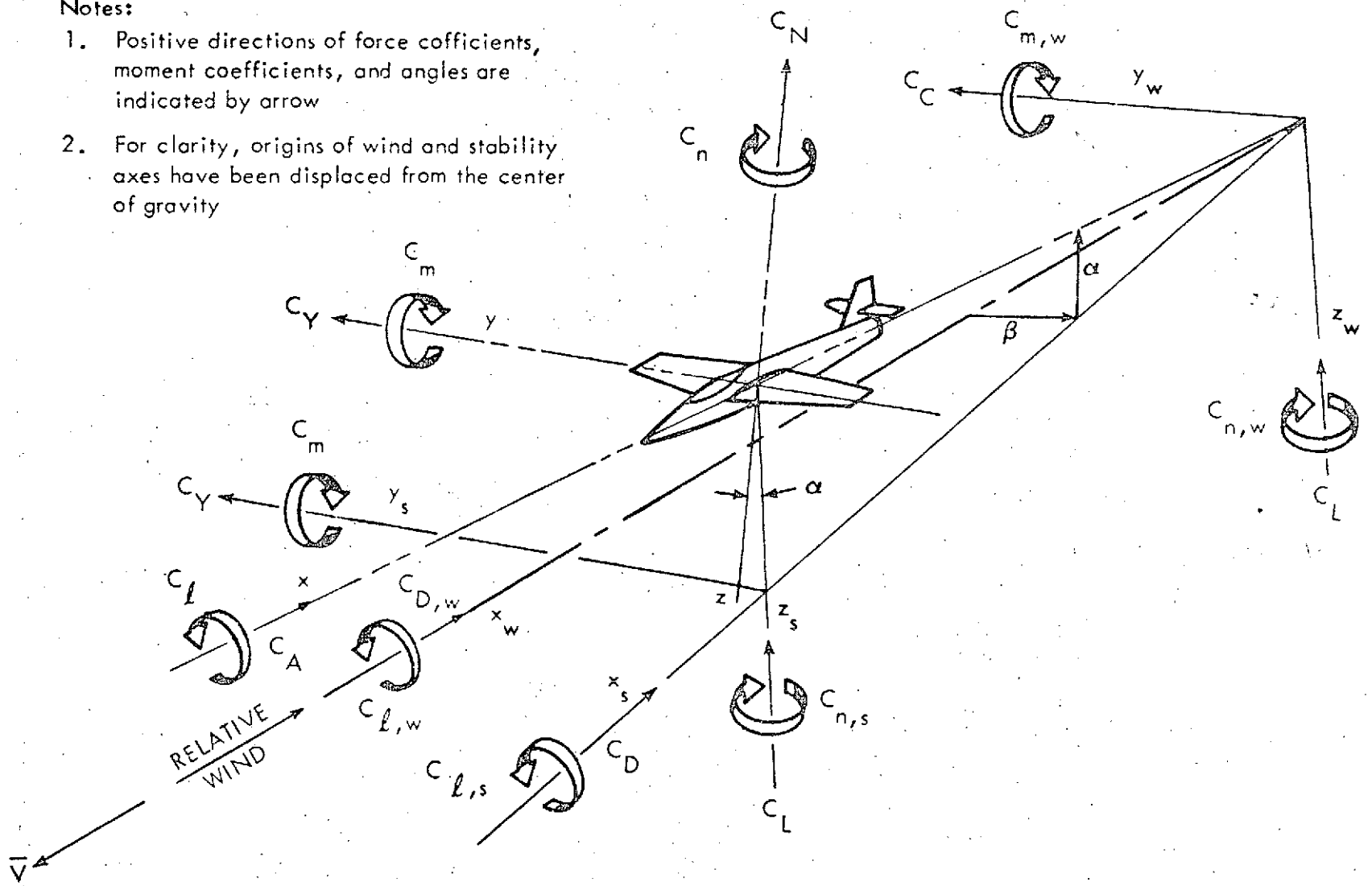
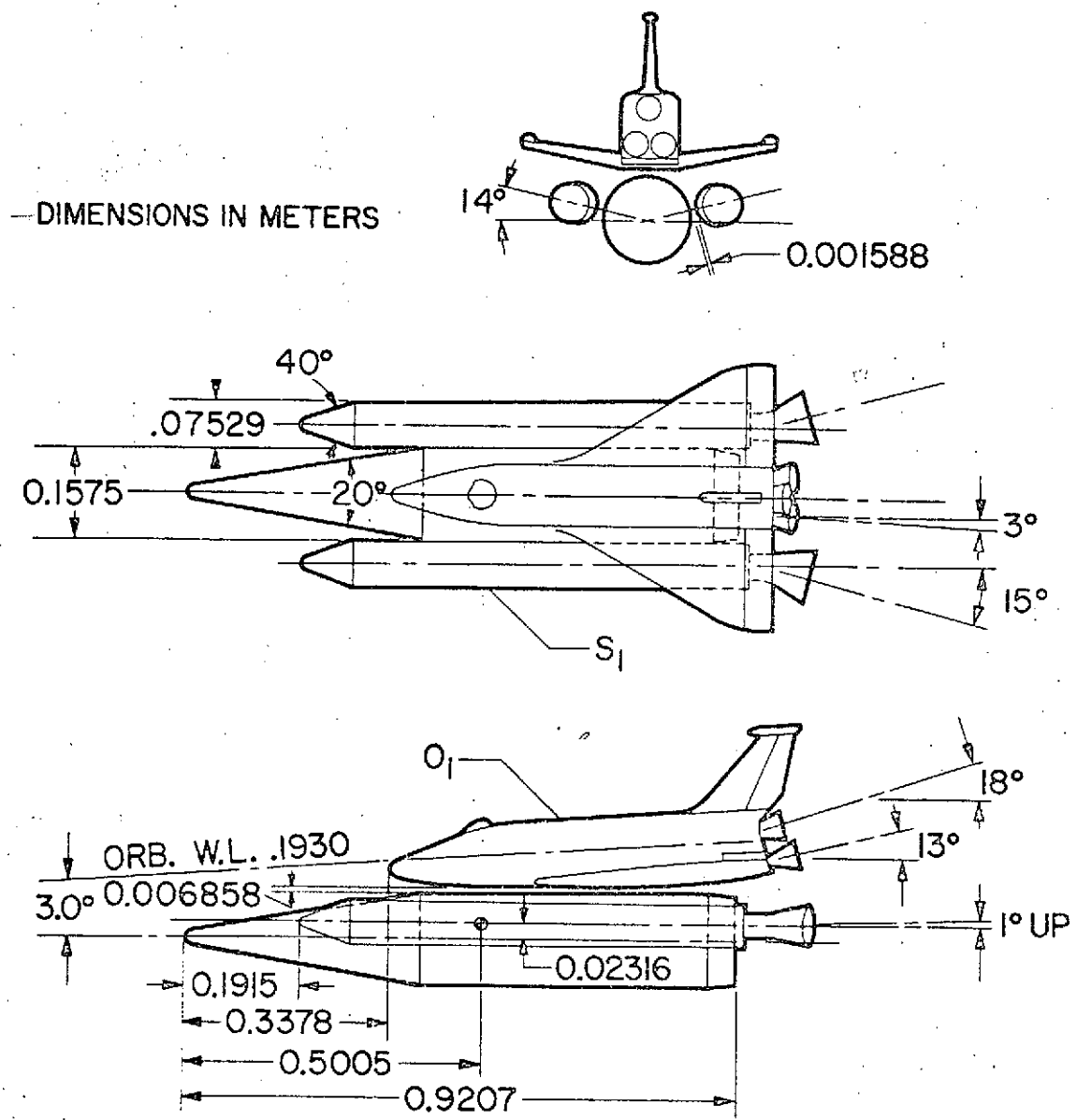

Figure 1. - Axis Systems.



(a) O40A Integrated vehicle

Figure 2. - Model description.

DIMENSIONS IN METERS

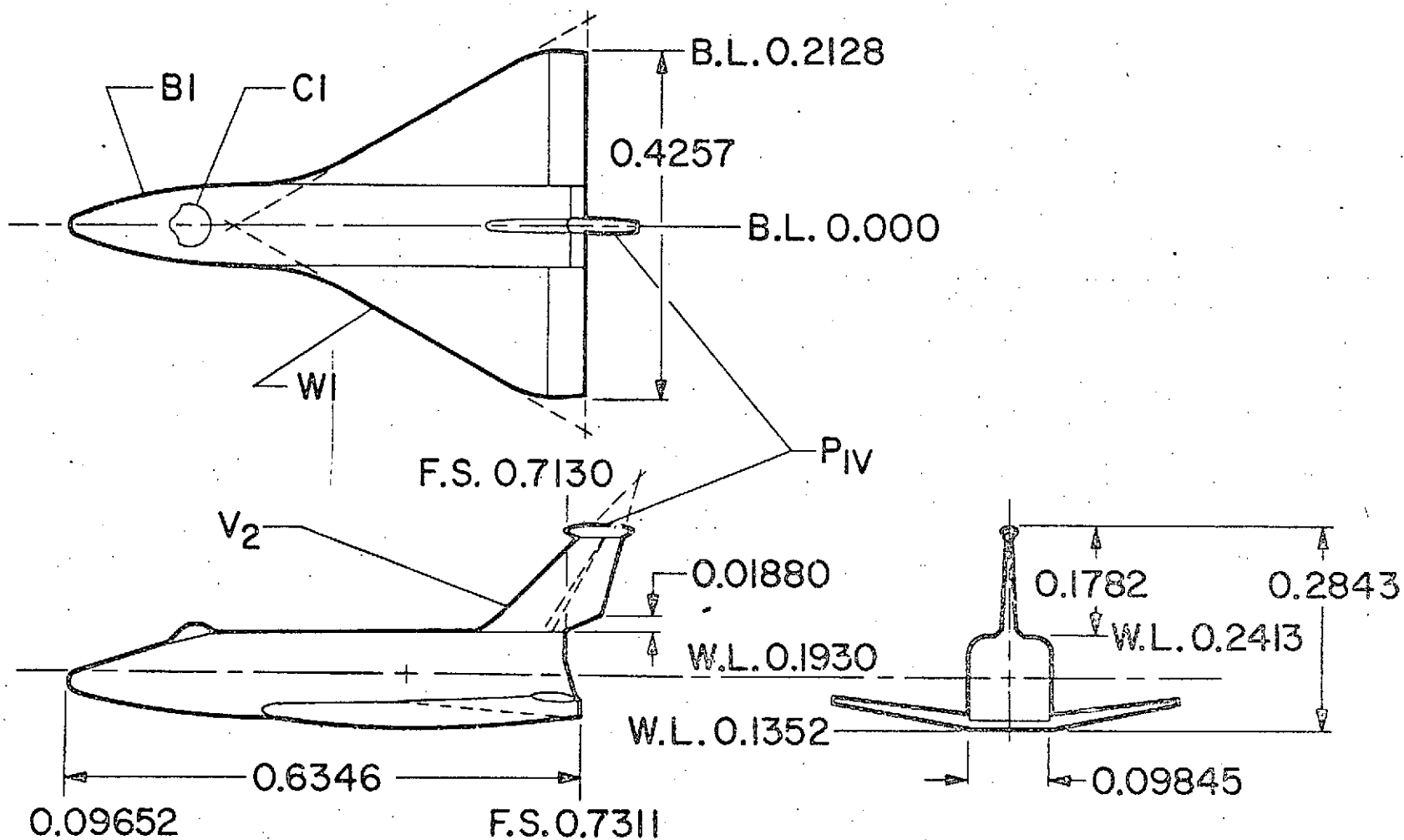

(b) Orbiter

Figure 2. - Continued.

DIMENSIONS IN METERS

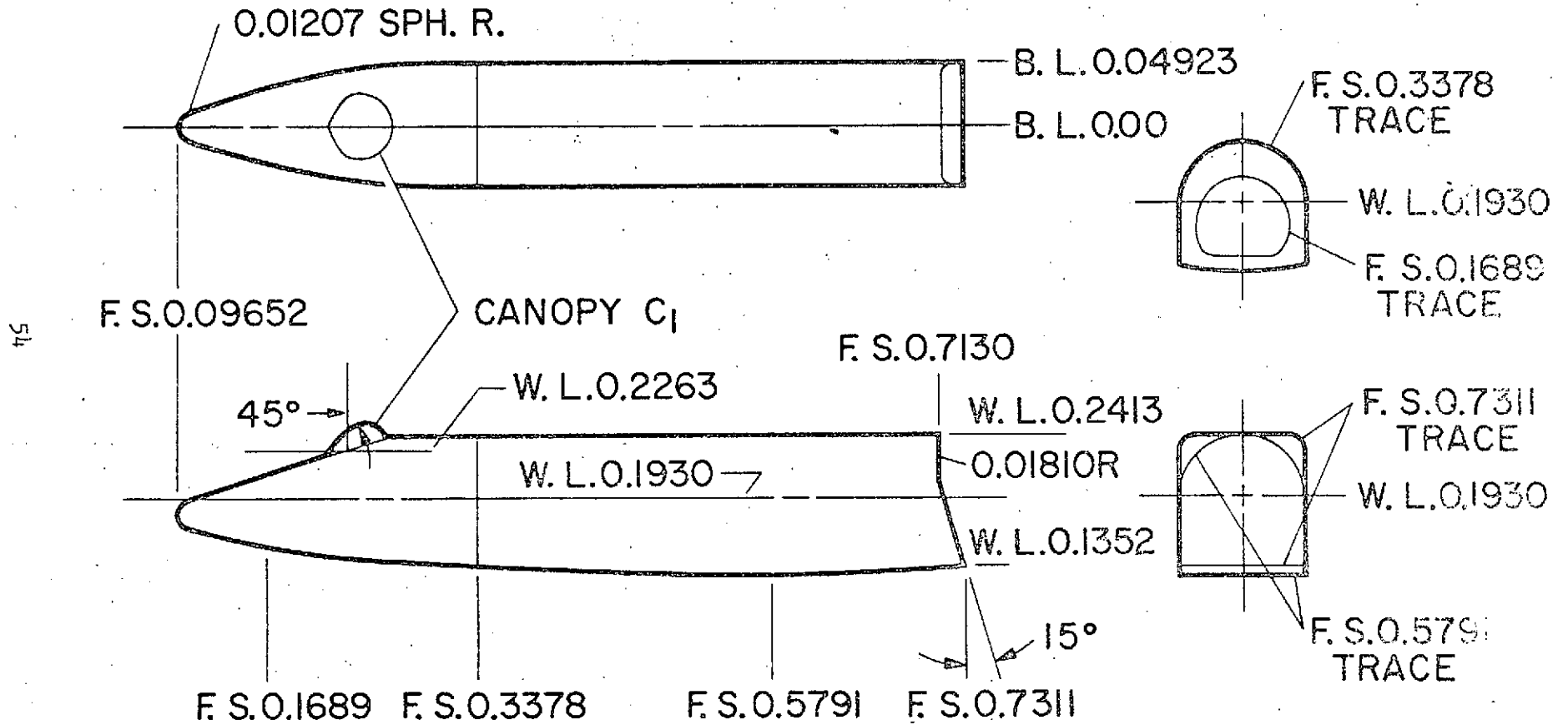

(c) Orbiter fuselage

Figure 2. - Continued.

DIMENSIONS IN METERS

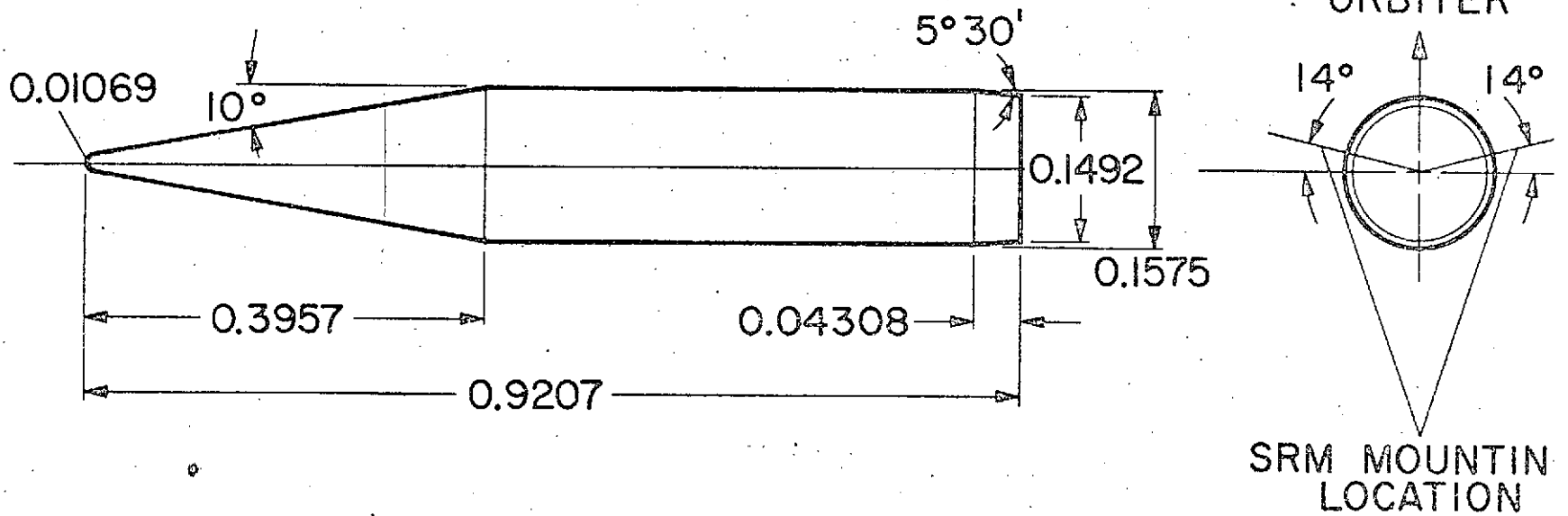

(a) EHOT

Figure 2. - Continued.

DIMENSIONS IN METERS

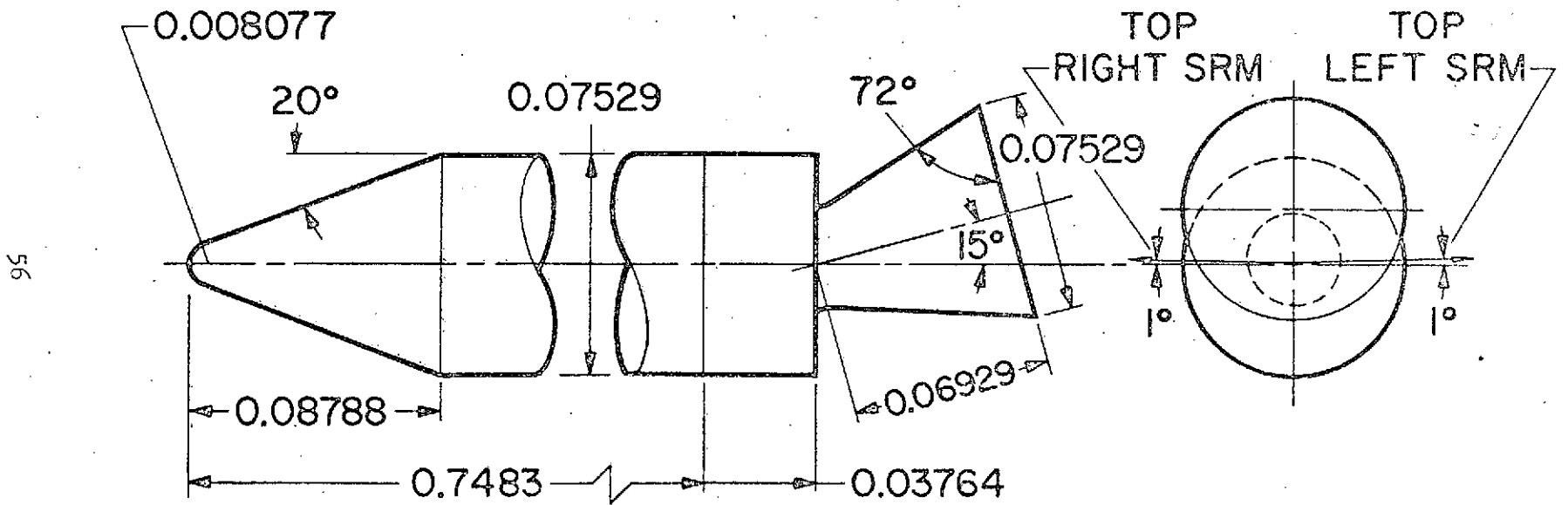

(e) Solid rocket motors, S1

Figure 2. - Continued.

DIMENSIONS IN METERS

ONE HALF BODY OF REVOLUTION
 CREATED THROUGH USE OF NASA
 633-018 AIRFOIL.
 TYPICAL EACH CORNER.

X, m	Y, m
0	0
0.0002769	0.0008941
0.0004140	0.001092
0.0006883	0.001412
0.001379	0.001979
0.002758	0.002779
0.004138	0.003381
0.005514	0.003866
0.008273	0.004602
0.01103	0.005126
0.01379	0.005479
0.01655	0.005677
0.01930	0.005733

L.E. RAD. = 0.001168

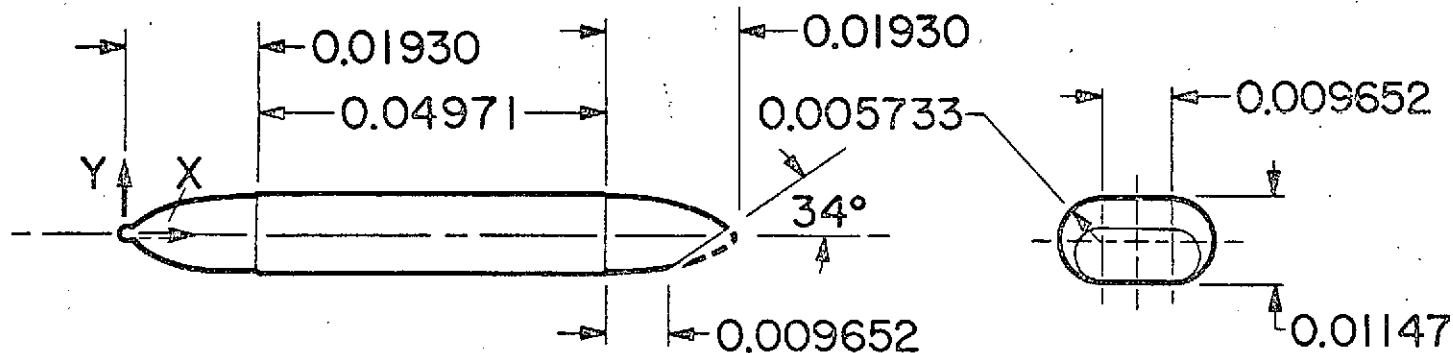
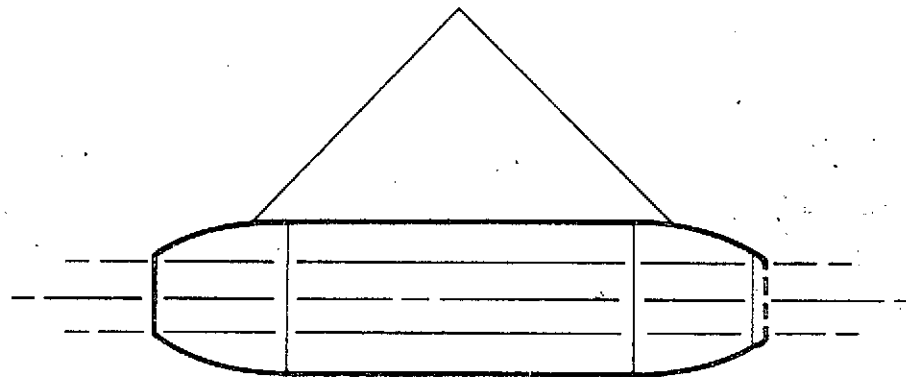

(f) Vertical tail ACPS pods PLV

Figure 2. - Continued.

NOTE: ALL DIMENSIONS ARE MODEL SCALE IN METERS

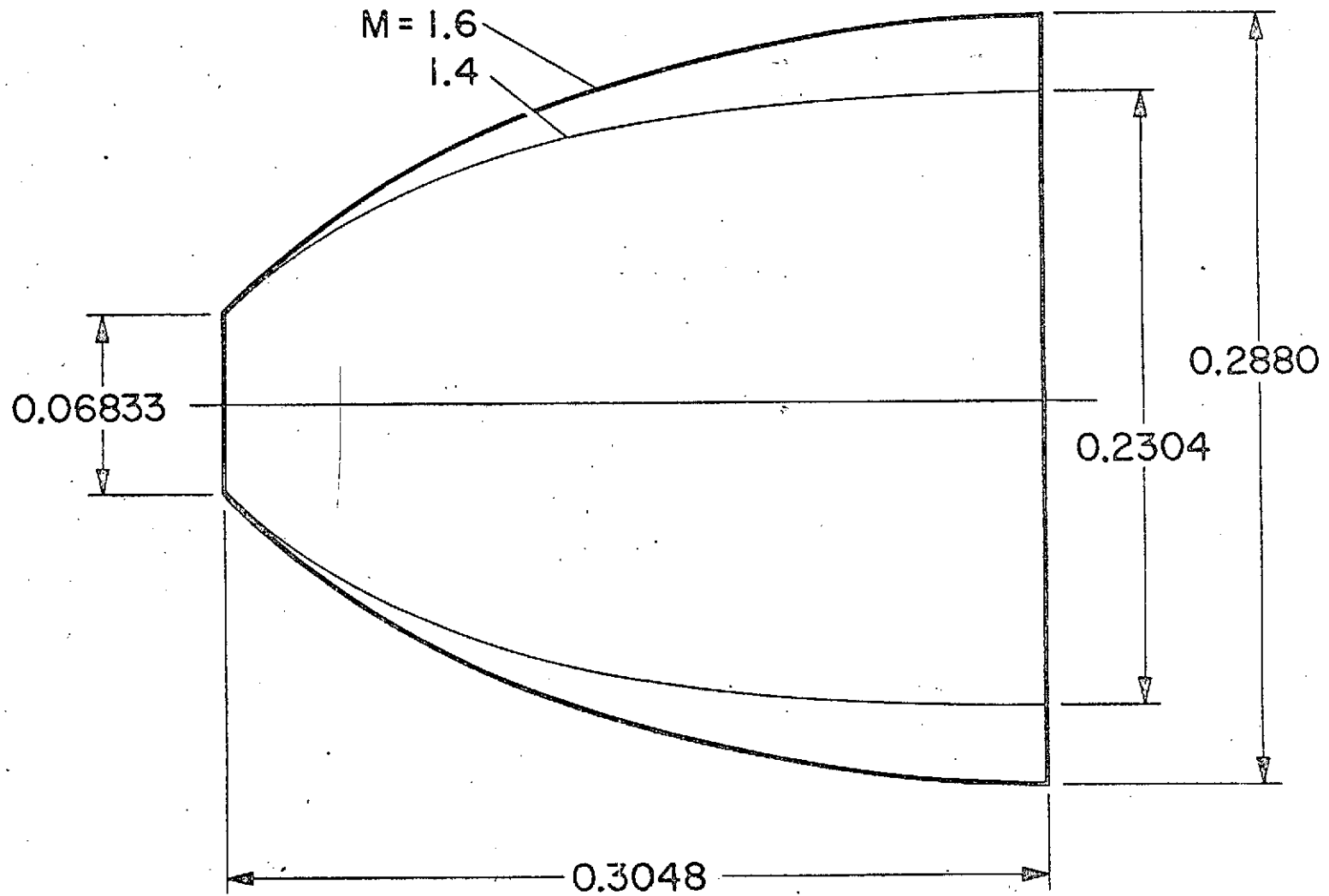

58

(g) SRM plumes

Figure 2. - Concluded.

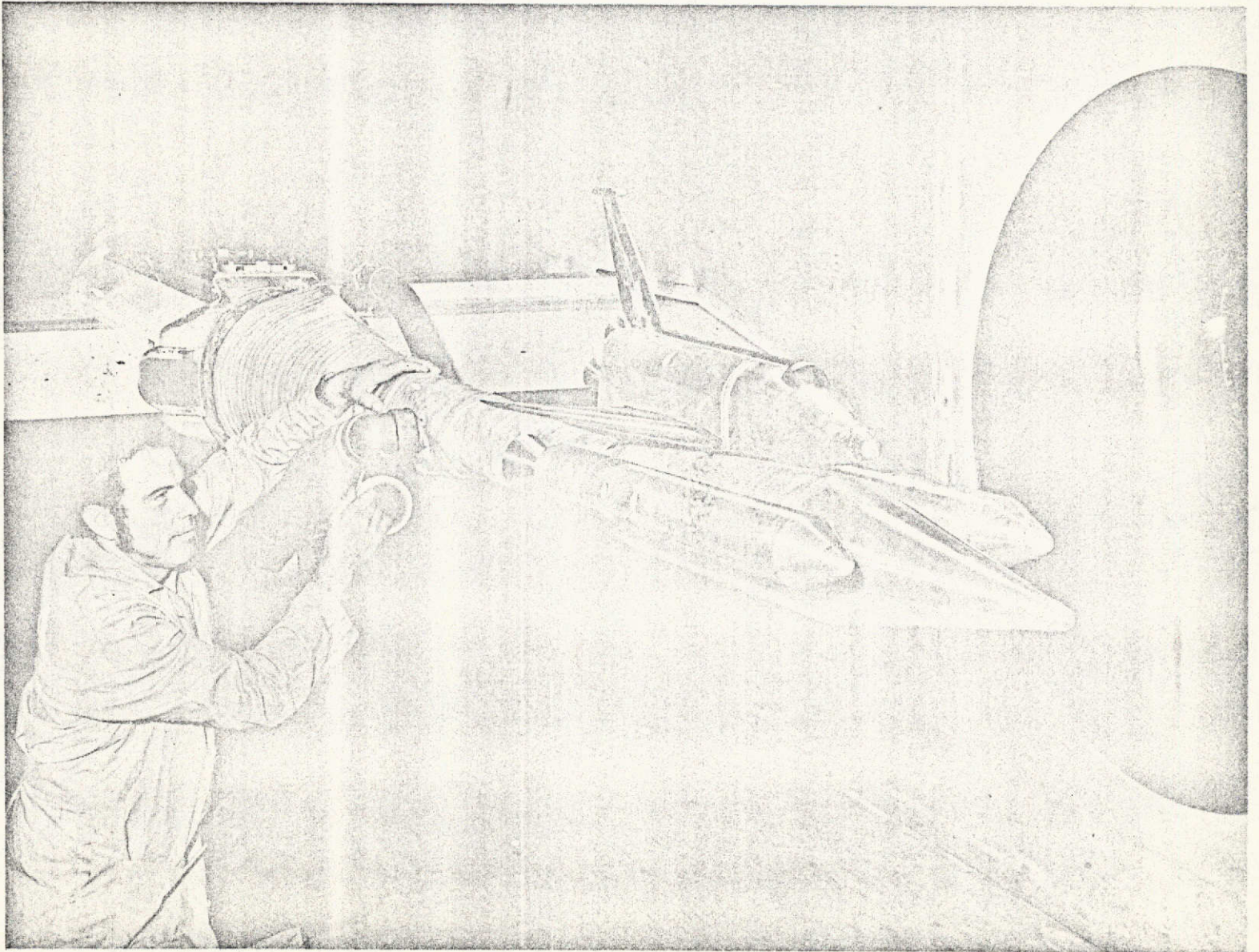

(a) Front view

Figure 3. - Installation of the 0.019-scale model launch configuration of the Space Shuttle Vehicle with the O40A orbiter.

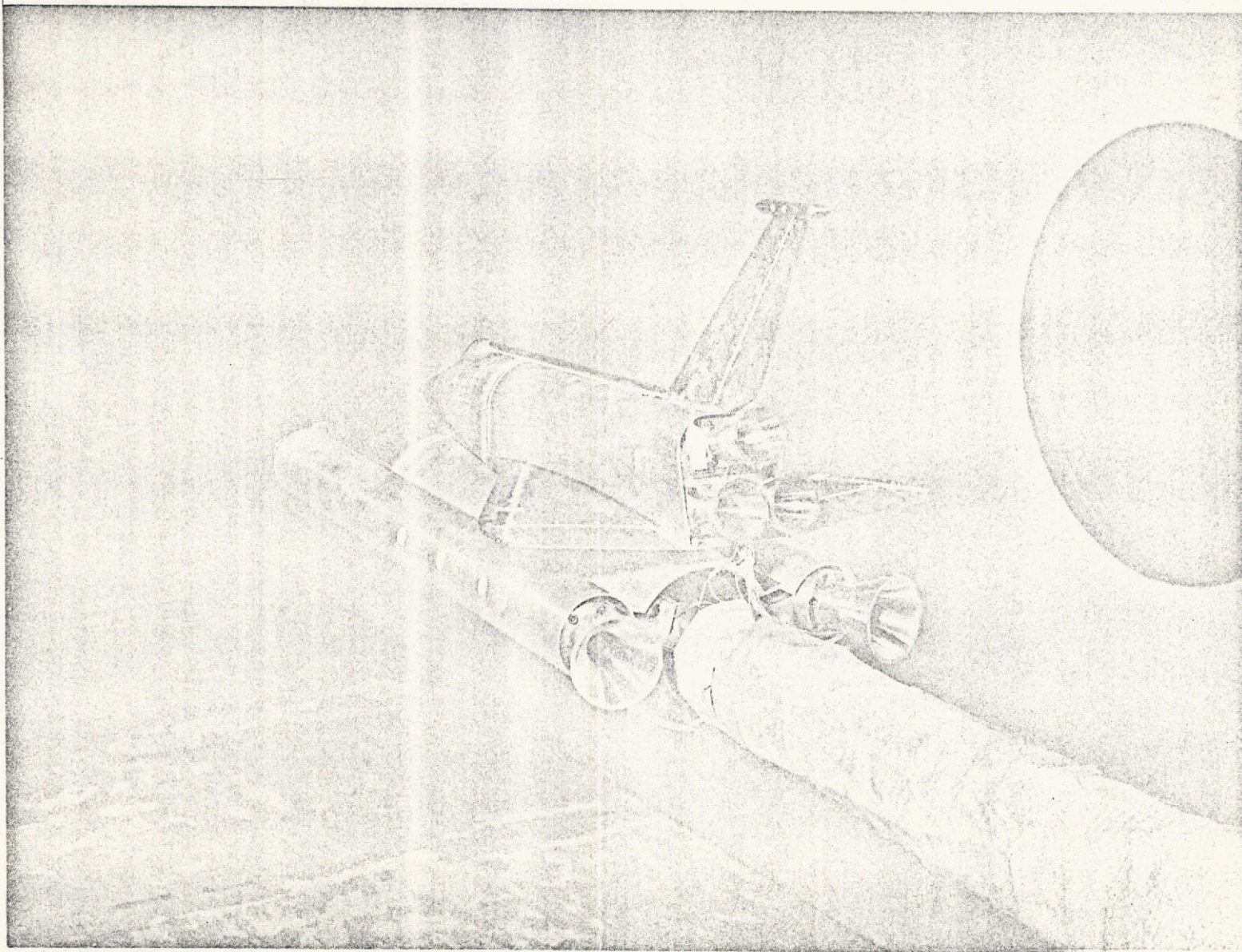

(b) Rear view

Figure 3. - Continued.

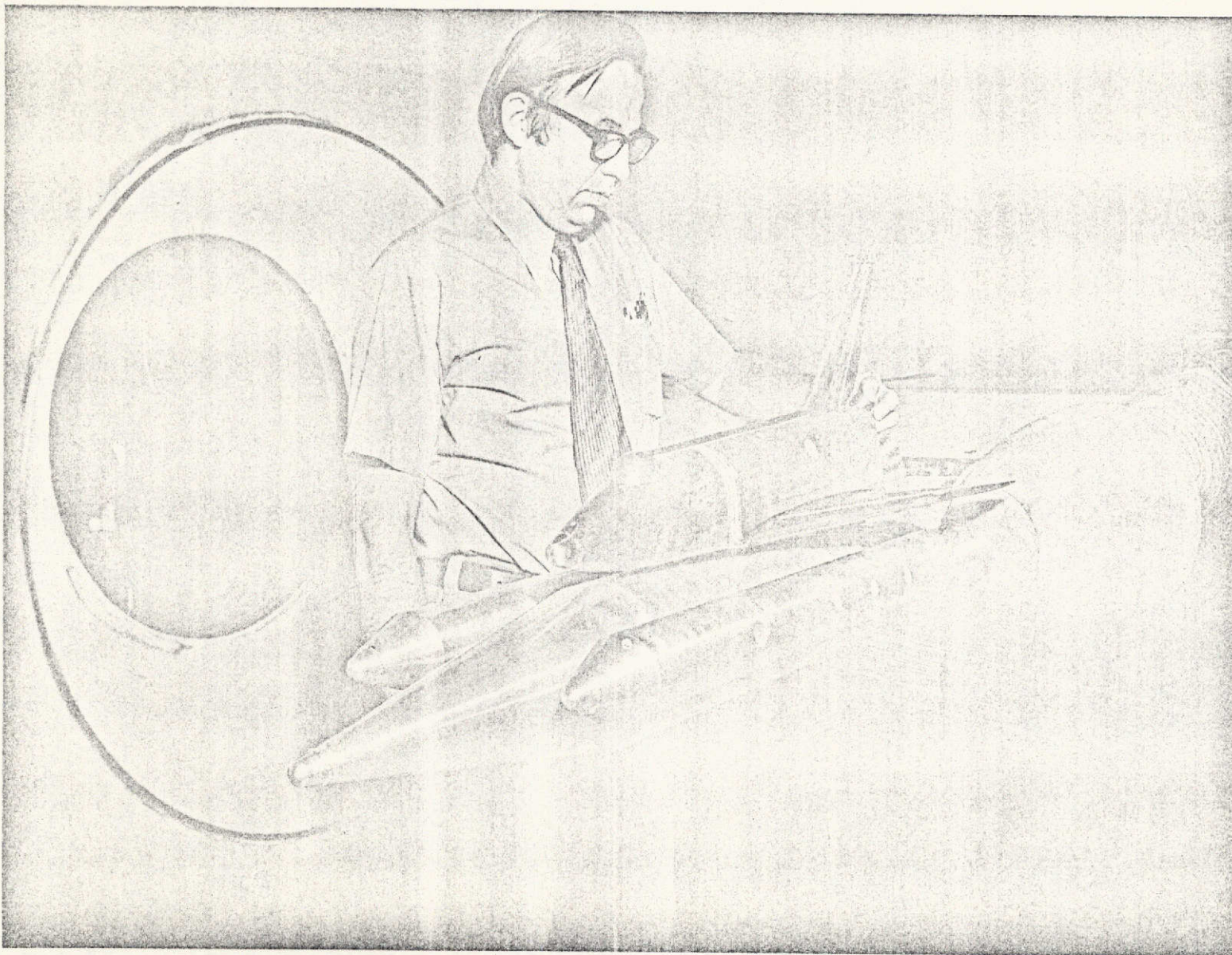

(c) Front view with $M = 1.4$ nozzle design solid plume simulators

Figure 3. - Concluded.

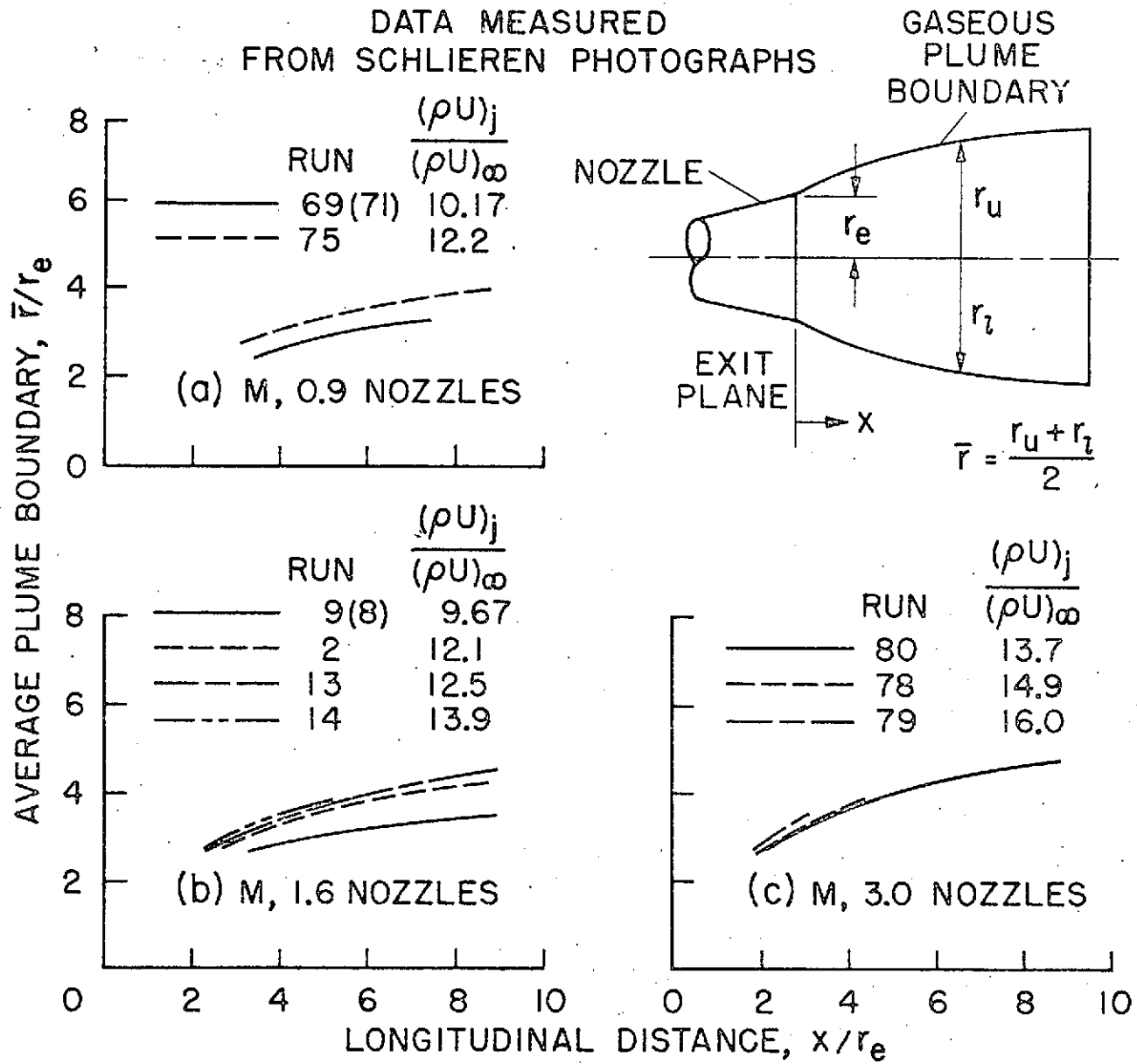

Figure 4. - Average plume shape variations with the viscous mixing parameter $(\rho U)_j / (\rho U)_\infty$ for various SRM nozzle designs at M = 1.6.

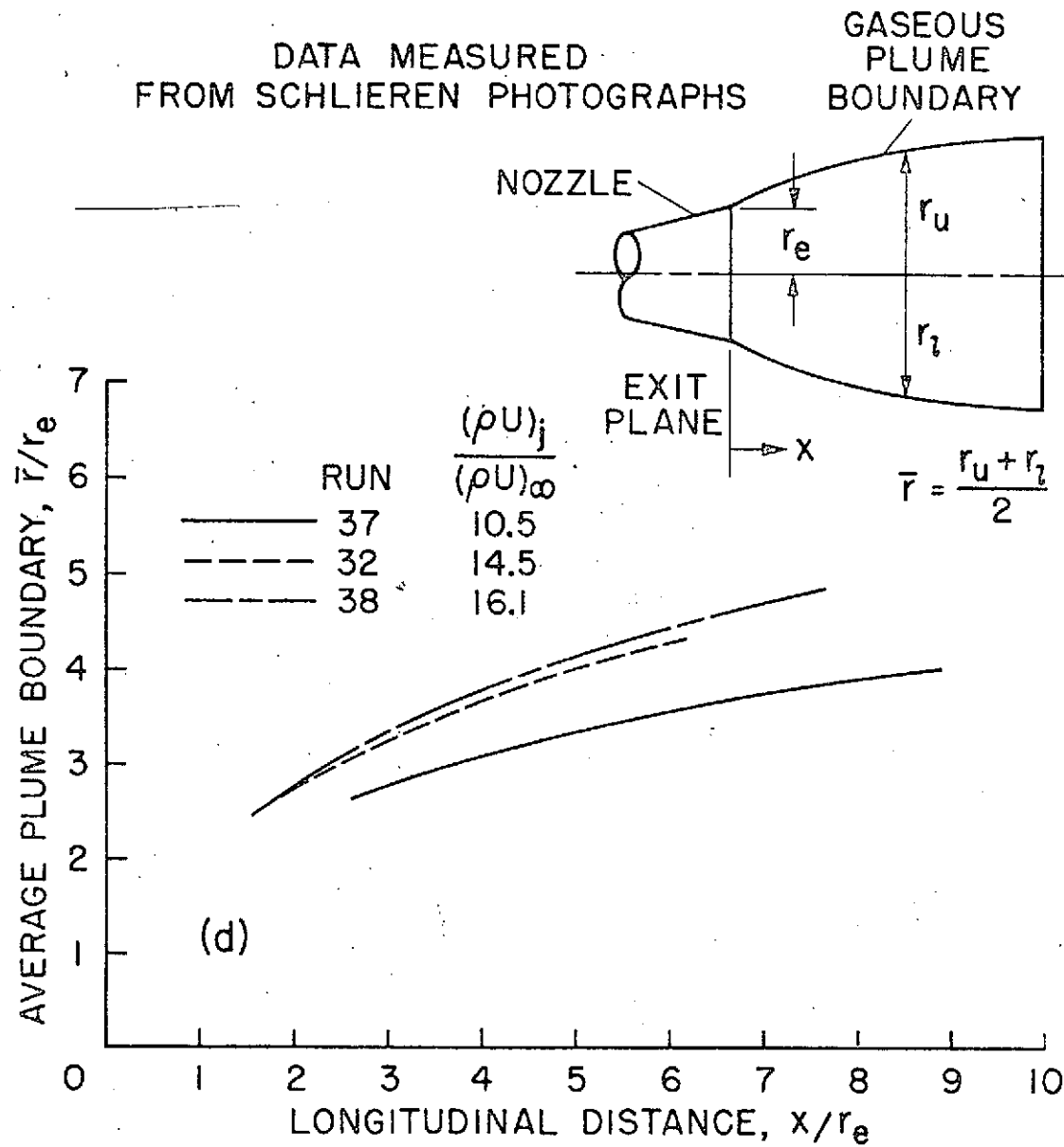

Figure 5. - Average SRM plume shape variations with the viscous mixing parameter $(\rho U)_j / (\rho U)_\infty$ for $M = 2.0$ nozzle design at $M = 2.0$.

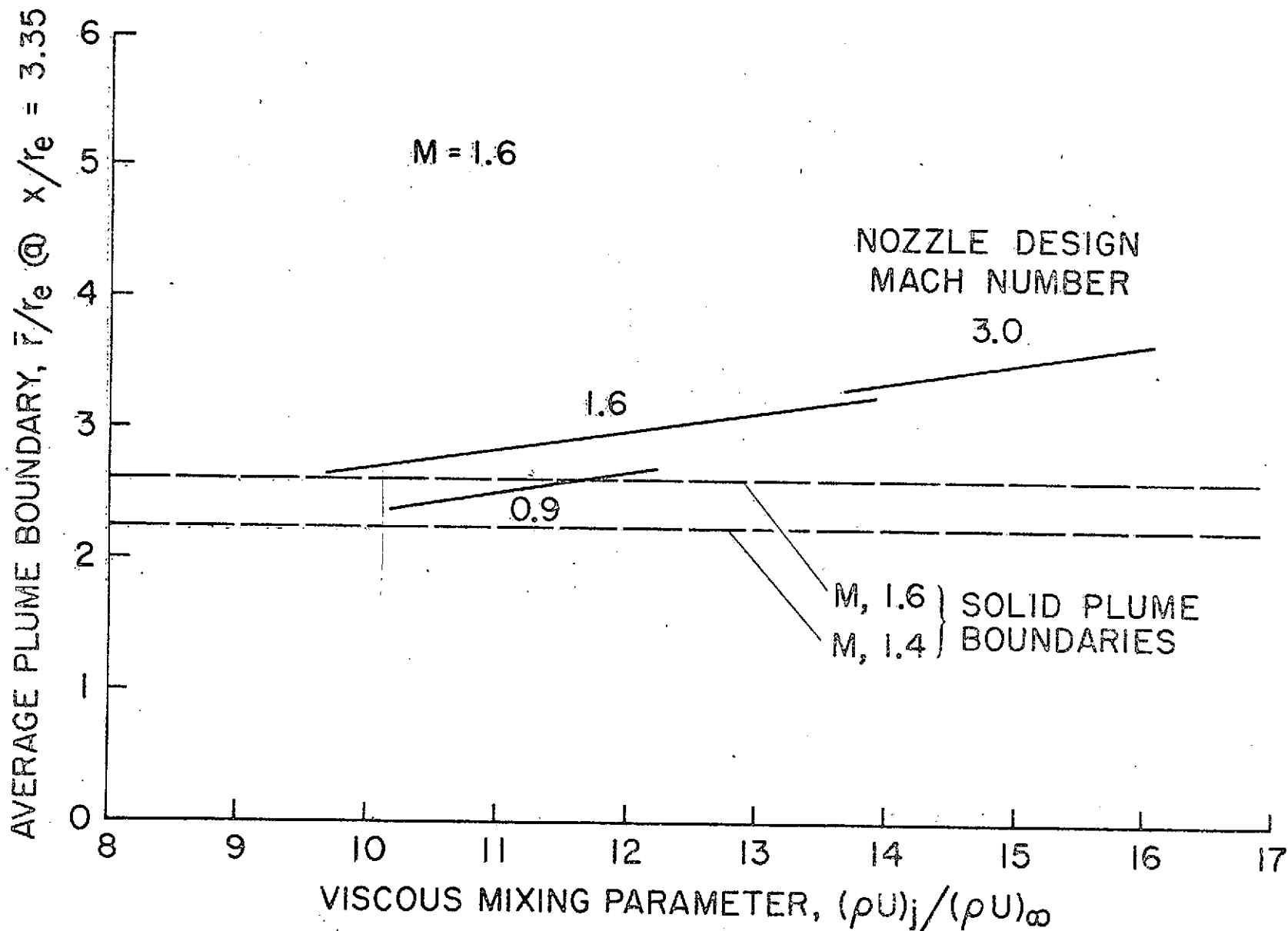

Figure 6. - Variation of the average gaseous SRM plume shape with the viscous mixing parameter at a given distance from the nozzle exit.

DATA FIGURES

DATA SET SYMBOL	CONFIGURATION DESCRIPTION	ELEVON	AILERON	RUDDER	PLUMES	REFERENCE INFORMATION		
(DBJ501)	AMES 97-616 1A2 01 TO S1 NO PLUMES	.000	.000	.000	.000	SREF	3155.0000	SQ.FT.
(DBJ001)	AMES 97-616 1A2 01 TO S1 PC/PT NOM. SRM A/A=8	.000	.000	.000	5.000	LREF	50.8000	FT.
(RBJ007)	AMES 97-616 1A2 01 TO S1 SRM A/A=12.0RB NOM	.000	.000	.000	5.000	BREF	73.5000	FT.
(RBJ009)	AMES 97-616 1A2 01 TO S1 PC/PT=1.3 NOMINAL	.000	.000	.000	5.000	XMRP	86.4167	FT.
						YMRP	.0000	FT.
						ZMRP	4.0000	FT.
						SCALE	.0190	

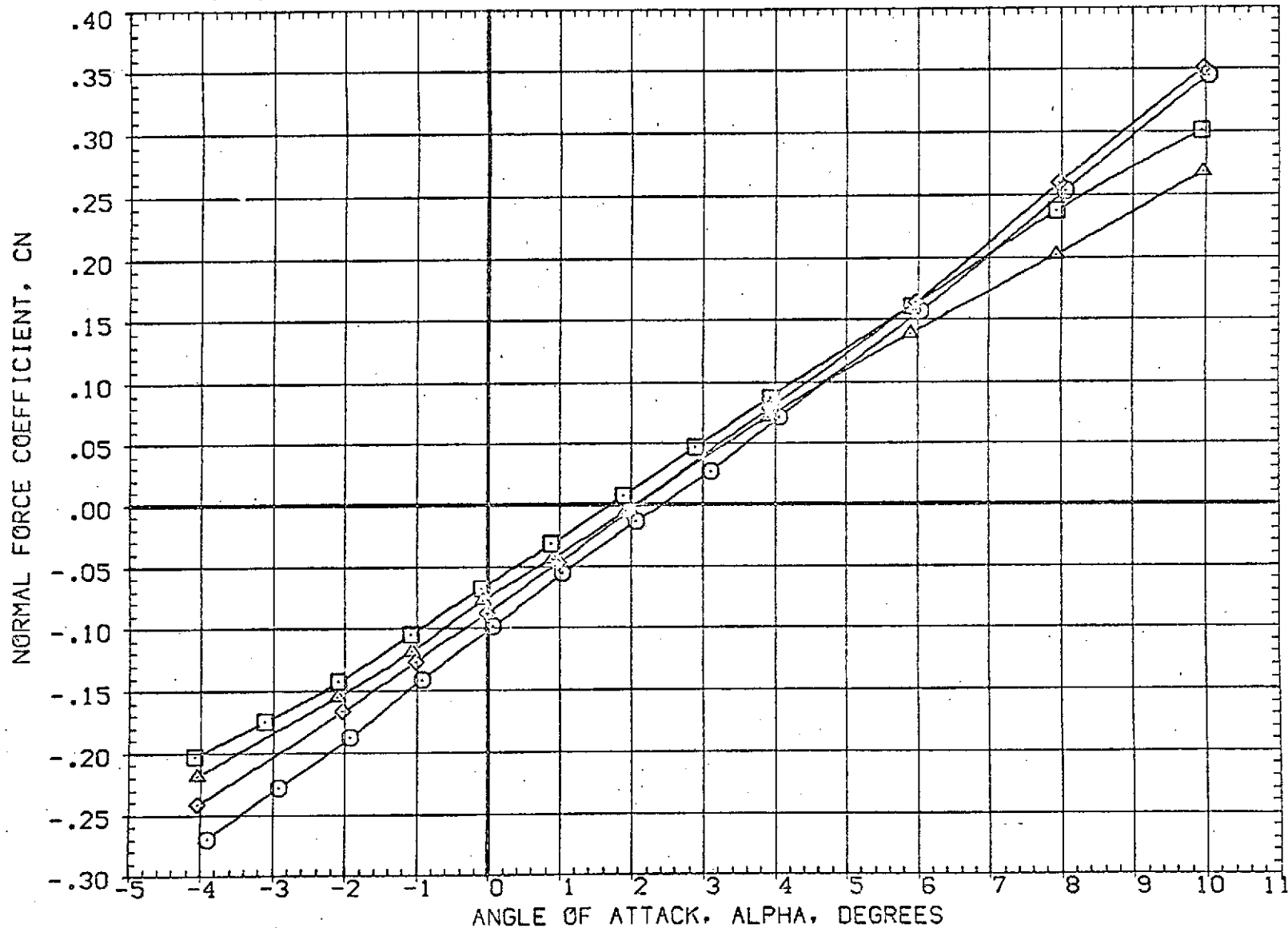

FIG 7 EFFECT OF PLUME SIZE ON LONGITUDINAL CHARACTERISTICS

(A)MACH = 1.60

DATA SET	SYMBOL	CONFIGURATION	DESCRIPTION	ELEVATION	ANGLE	REF	SCALE	UNIT
(02:501)	○	AMES 97-616 1A2 01 TO S1	NO PLUMES	.000	.000	.000	5.000	SREF 3155.0000 SQ.FT.
(03:001)	□	AMES 97-616 1A2 01 TO S1	PC/PT NOM. SRM A/A=8	.000	.000	.000	5.000	LREF 50.8000 FT.
(R3:007)	◇	AMES 97-616 1A2 01 TO S1	SRM A/A=12.0RB NOM	.000	.000	.000	5.000	BREF 73.5000 FT.
(R2:009)	△	AMES 97-616 1A2 01 TO S1	PC/PT=1.3 NOMINAL	.000	.000	.000	5.000	XMRP 86.4167 FT.
								YMRP .0000 FT.
								ZMRP 4.0000 FT.
								SCALE .0190

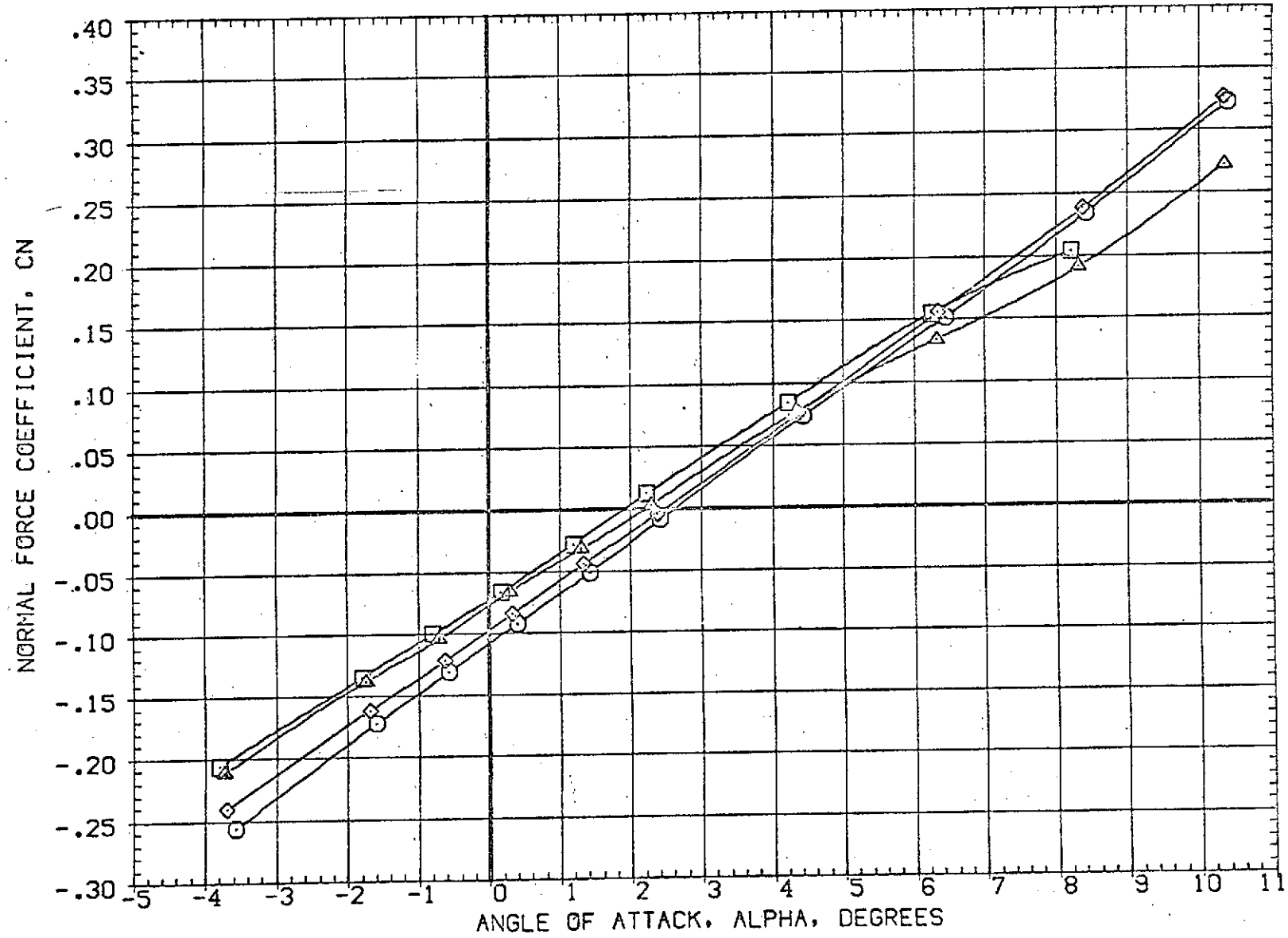

FIG 7 EFFECT OF PLUME SIZE ON LONGITUDINAL CHARACTERISTICS
 (B)MACH = 1.98

DATA SET SYMBOL	CONFIGURATION DESCRIPTION	ELEVON	AILERON	RUDDER	PLUMES	REFERENCE INFORMATION		
(OBJ501)	AMES 97-616 1A2 01 TO S1 NO PLUMES	.000	.000	.000	.000	SREF	3155.0000	SQ.FT.
(OBJ001)	AMES 97-616 1A2 01 TO S1 PC/PT NOM, SRM A/A=8	.000	.000	.000	5.000	LREF	50.8000	FT.
(RBJ007)	AMES 97-616 1A2 01 TO S1 SRM A/A=12, ORB NOM	.000	.000	.000	5.000	BREF	73.5000	FT.
(RBJ009)	AMES 97-616 1A2 01 TO S1 PC/PT=1.3 NOMINAL	.000	.000	.000	5.000	XMRP	85.4167	FT.
						YMRP	.0000	FT.
						ZMRP	4.0000	FT.
						SCALE	.0190	

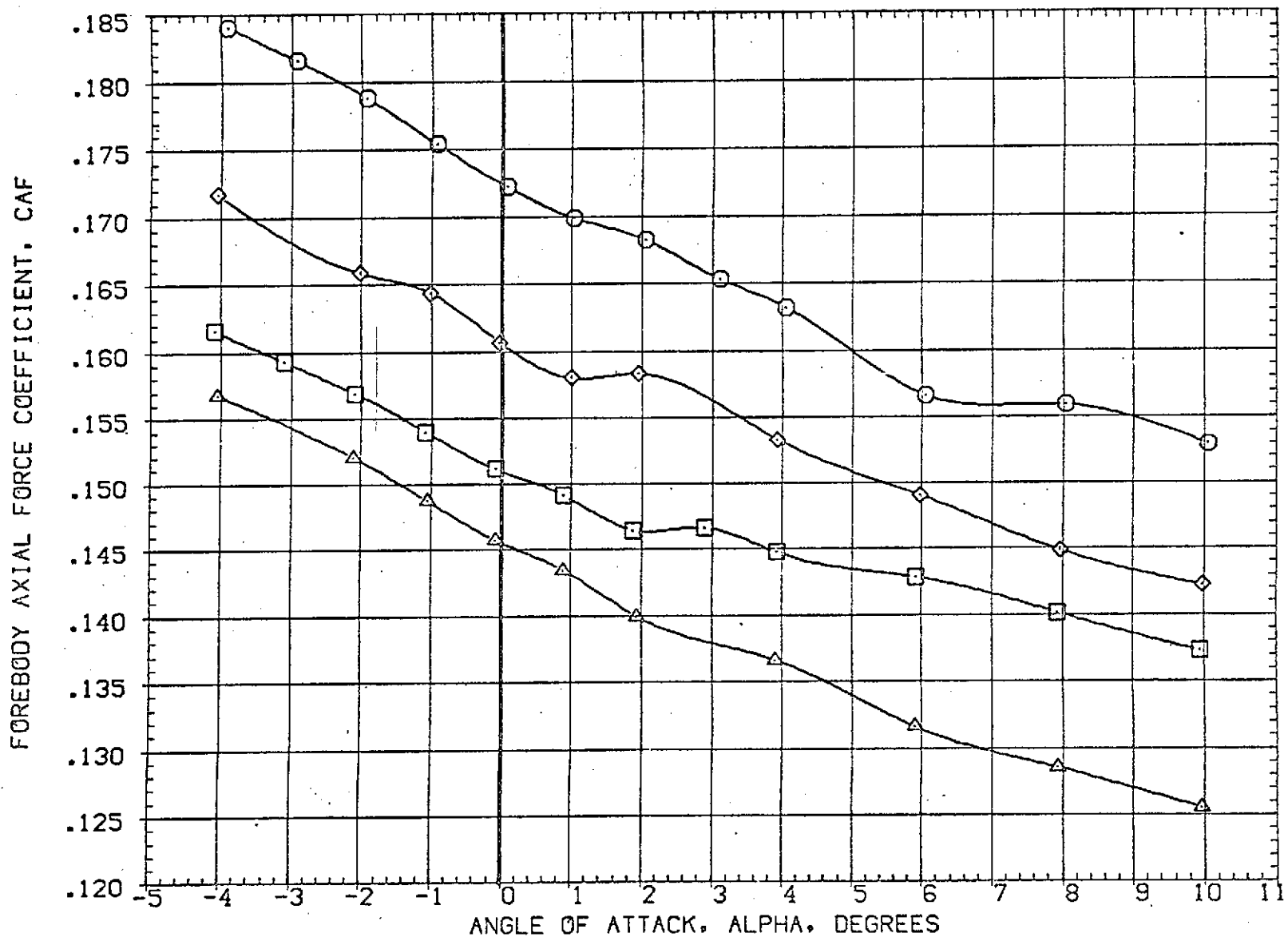

FIG 7 EFFECT OF PLUME SIZE ON LONGITUDINAL CHARACTERISTICS

(A)MACH = 1.60

DATA SET SYMBOL	CONFIGURATION DESCRIPTION	ELEVON	AILRON	RUDDER	PLUMES	REFERENCE INFORMATION
(DBJ501)	AMES 97-616 IA2 01 TO S1 NO PLUMES	.000	.000	.000	.000	SREF 3155.0000 SQ.FT.
(DBJ001)	AMES 97-616 IA2 01 TO S1 PC/PT NOM, SRM A/A=8	.000	.000	.000	5.000	LREF 50.8000 FT.
(RBJ007)	AMES 97-616 IA2 01 TO S1 SRM A/A=12, DRB NOM	.000	.000	.000	5.000	BREF 73.5000 FT.
(RBJ009)	AMES 97-616 IA2 01 TO S1 PC/PT=1.3 NOMINAL	.000	.000	.000	5.000	XMRP 85.4167 FT.
						YMRP .0000 FT.
						ZMRP 4.0000 FT.
						SCALE .0190

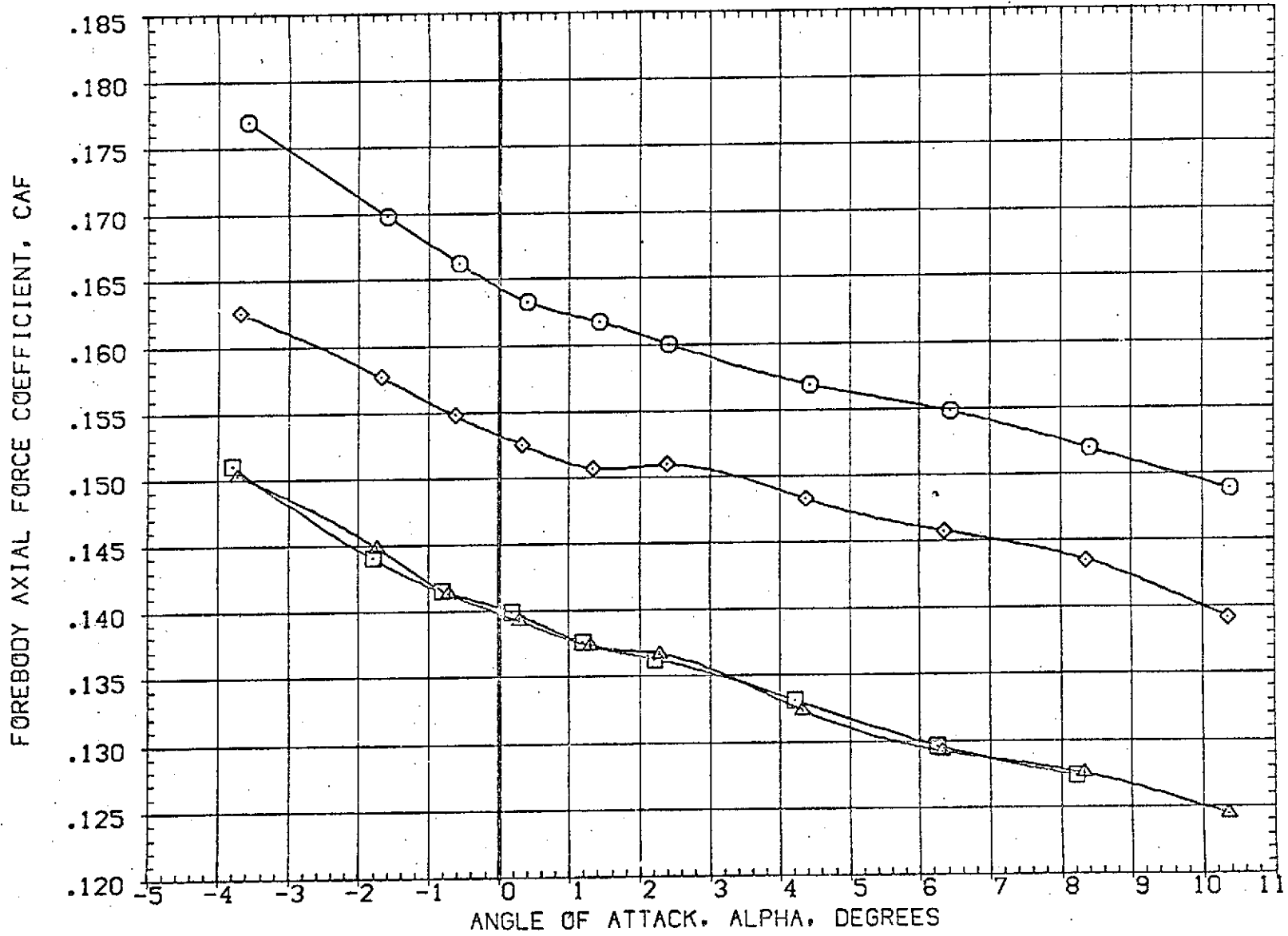

FIG 7 EFFECT OF PLUME SIZE ON LONGITUDINAL CHARACTERISTICS

(B)MACH = 1.98

DATA SET	SYMBOL	CONFIGURATION DESCRIPTION	ELEVON	AILRON	RUDDER	PLUMES	REFERENCE INFORMATION	
(DBJ501)	○	AMES 97-616 1A2 01 TO S1 NO PLUMES	.000	.000	.000	.000	SREF	3155.0000 SQ.FT.
(DBJ001)	□	AMES 97-616 1A2 01 TO S1 PC/PT NOM, SRM A/A=8	.000	.000	.000	5.000	LREF	50.8000 FT.
(RBJ007)	◇	AMES 97-616 1A2 01 TO S1 SRM A/A=12, CR8 NOM	.000	.000	.000	5.000	BREF	73.5000 FT.
(RBJ009)	△	AMES 97-616 1A2 01 TO S1 PC/PT=1.3 NOMINAL	.000	.000	.000	5.000	XMRP	86.4167 FT.
							YMRP	.0000 FT.
							ZMRP	4.0000 FT.
							SCALE	.0190

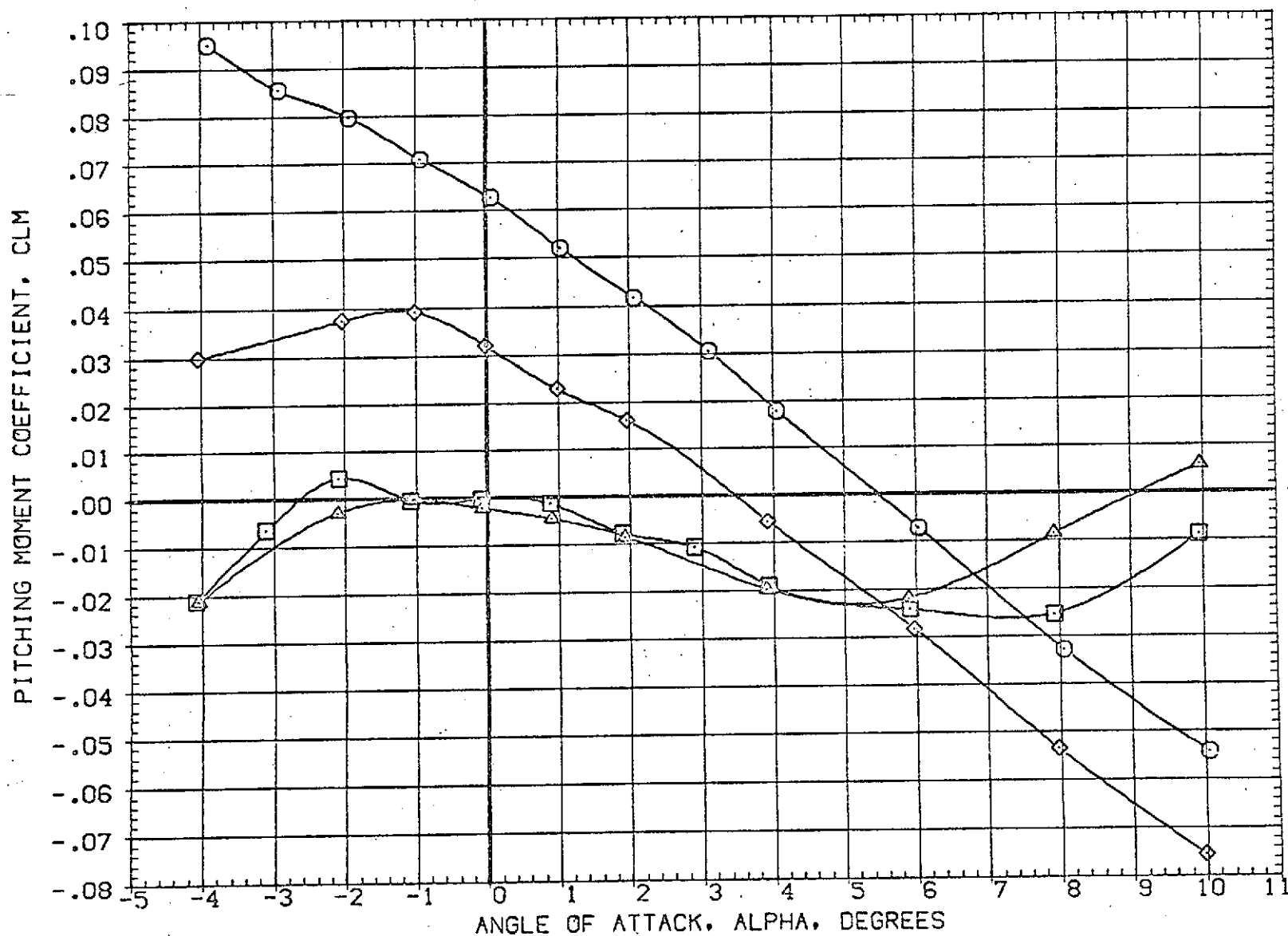

FIG 7 EFFECT OF PLUME SIZE ON LONGITUDINAL CHARACTERISTICS

(A)MACH = 1.60

DATA SET SYMBOL	CONFIGURATION DESCRIPTION	ELEVON	AILERON	RUDDER	PLUMES	REFERENCE IN INCHES	SO.FT.
(DBJ501)	AMES 97-616 IA2 01 TO S1 NO PLUMES	.000	.000	.000	.000	SREF	3155.0000
(DBJ001)	AMES 97-616 IA2 01 TO S1 PC/PT NOM, SRM A/A=8	.000	.000	.000	5.000	LREF	50.8000
(RBJ007)	AMES 97-616 IA2 01 TO S1 SRM A/A=12, CRB NOM	.000	.000	.000	5.000	BREF	73.5000
(RBJ009)	AMES 97-616 IA2 01 TO S1 PC/PT=1.3 NOMINAL	.000	.000	.000	5.000	XMRP	86.4167
						YMRP	.0000
						ZMRP	4.0000
						SCALE	.0190

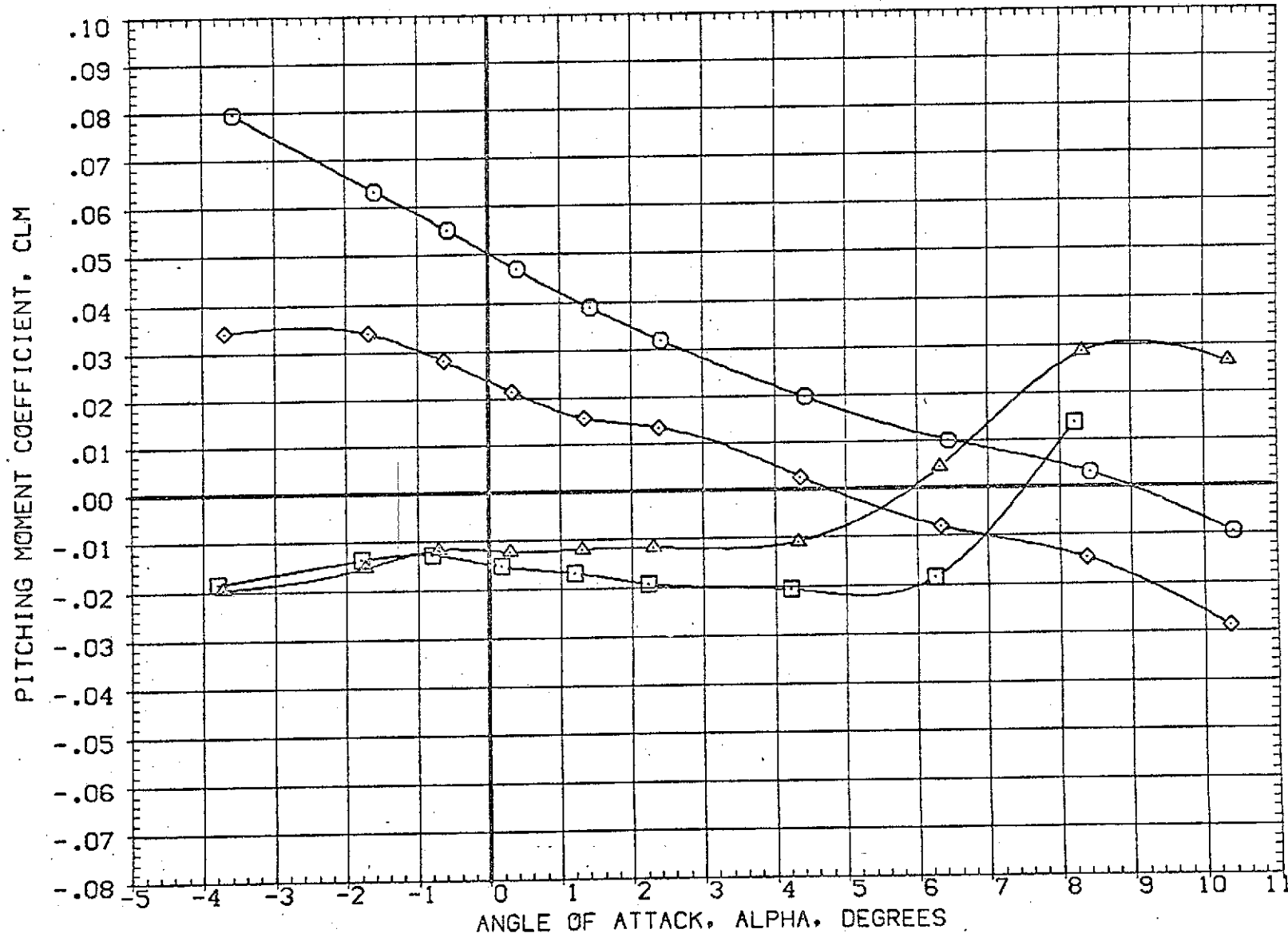

FIG 7 EFFECT OF PLUME SIZE ON LONGITUDINAL CHARACTERISTICS
 (B)MACH = 1.98

DATA SET SYMBOL	CONFIGURATION DESCRIPTION	ELEVON	AILRON	RUDDER	PLUMES	REFERENCE INFORMATION	
(09J501)	AMES 97-616 1A2 01 TO S1 NO PLUMES	.000	.000	.000	.000	SREF	3155.0000 SQ.FT.
(09J001)	AMES 97-616 1A2 01 TO S1 PC/PT NOM, SRM A/A=8	.000	.000	.000	5.000	LREF	50.8000 FT.
(RBJ007)	AMES 97-616 1A2 01 TO S1 SRM A/A=12, CRB NOM	.000	.000	.000	5.000	BREF	73.5000 FT.
(RBZ009)	AMES 97-616 1A2 01 TO S1 PC/PT=1.3 NOMINAL	.000	.000	.000	5.000	XMRP	86.4167 FT.
						YMRP	.0000 FT.
						ZMRP	4.0000 FT.
						SCALE	.0:30

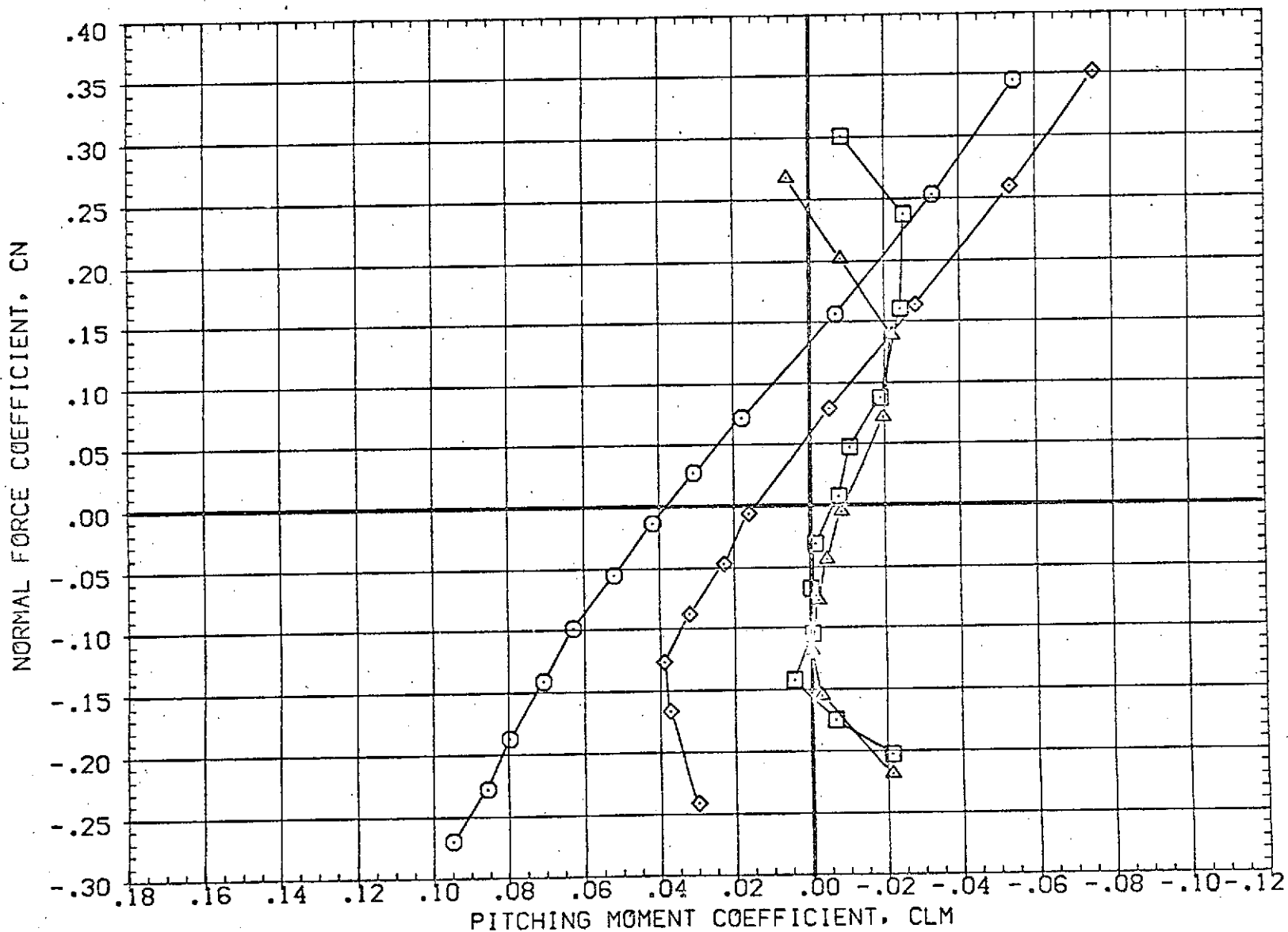

FIG 7 EFFECT OF PLUME SIZE ON LONGITUDINAL CHARACTERISTICS

(A)MACH = 1.60

DATA SET	SYMBOL	CONFIGURATION DESCRIPTION	ELEVON	WING	NOSE	TAIL	SREF	SO.FT.
(RBJ001)	○	AMES 97-616 1A2 01 TO S1 NO PLUMES	.000	.000	.000	.000	3155.0000	FT.
(RBJ001)	□	AMES 97-616 1A2 01 TO S1 PC/PT NOM. SRM A/A=8	.000	.000	.000	5.000	50.8000	FT.
(RBJ007)	◇	AMES 97-616 1A2 01 TO S1 SRM A/A=12.0R8 NOM	.000	.000	.000	5.000	73.5000	FT.
(RBJ009)	△	AMES 97-616 1A2 01 TO S1 PC/PT=1.3 NOMINAL	.000	.000	.000	5.000	88.4167	FT.
							XMRP	.0000
							YMRP	4.0000
							ZMRP	FT.
							SCALE	.0190

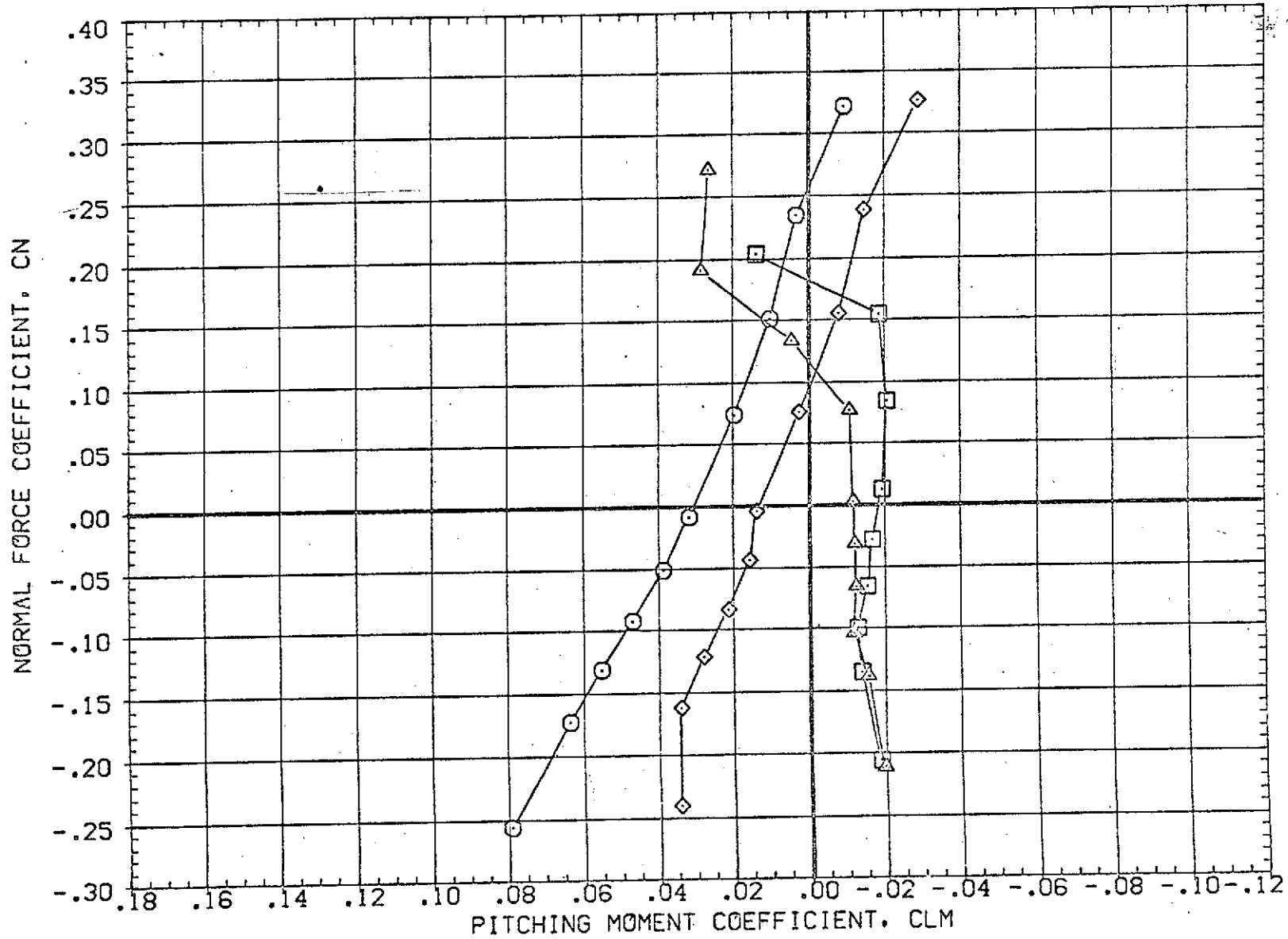

FIG 7 EFFECT OF PLUME SIZE ON LONGITUDINAL CHARACTERISTICS

(B)MACH = 1.98

DATA SET SYMBOL	CONFIGURATION DESCRIPTION	ELEVON	AILRON	RUDDER	PLUMES	REFERENCE INFORMATION		
(DBJ501)	AMES 97-616 1A2 01 TO S1 NO PLUMES	.000	.000	.000	.000	SREF	3155.0000	SQ.FT.
(DBJ031)	AMES 97-616 1A2 01 TO S1 PC/PT NOM. SRM A/A=8	.000	.000	.000	5.000	LREF	50.8000	FT.
(RBJ007)	AMES 97-616 1A2 01 TO S1 SRM A/A=12.0RB NOM	.000	.000	.000	5.000	BREF	73.5000	FT.
(RBJ009)	AMES 97-616 1A2 01 TO S1 PC/PT=1.3 NOMINAL	.000	.000	.000	5.000	XMRP	86.4167	FT.
						YMRP	.0000	FT.
						ZMRP	4.0000	FT.
						SCALE	.0190	

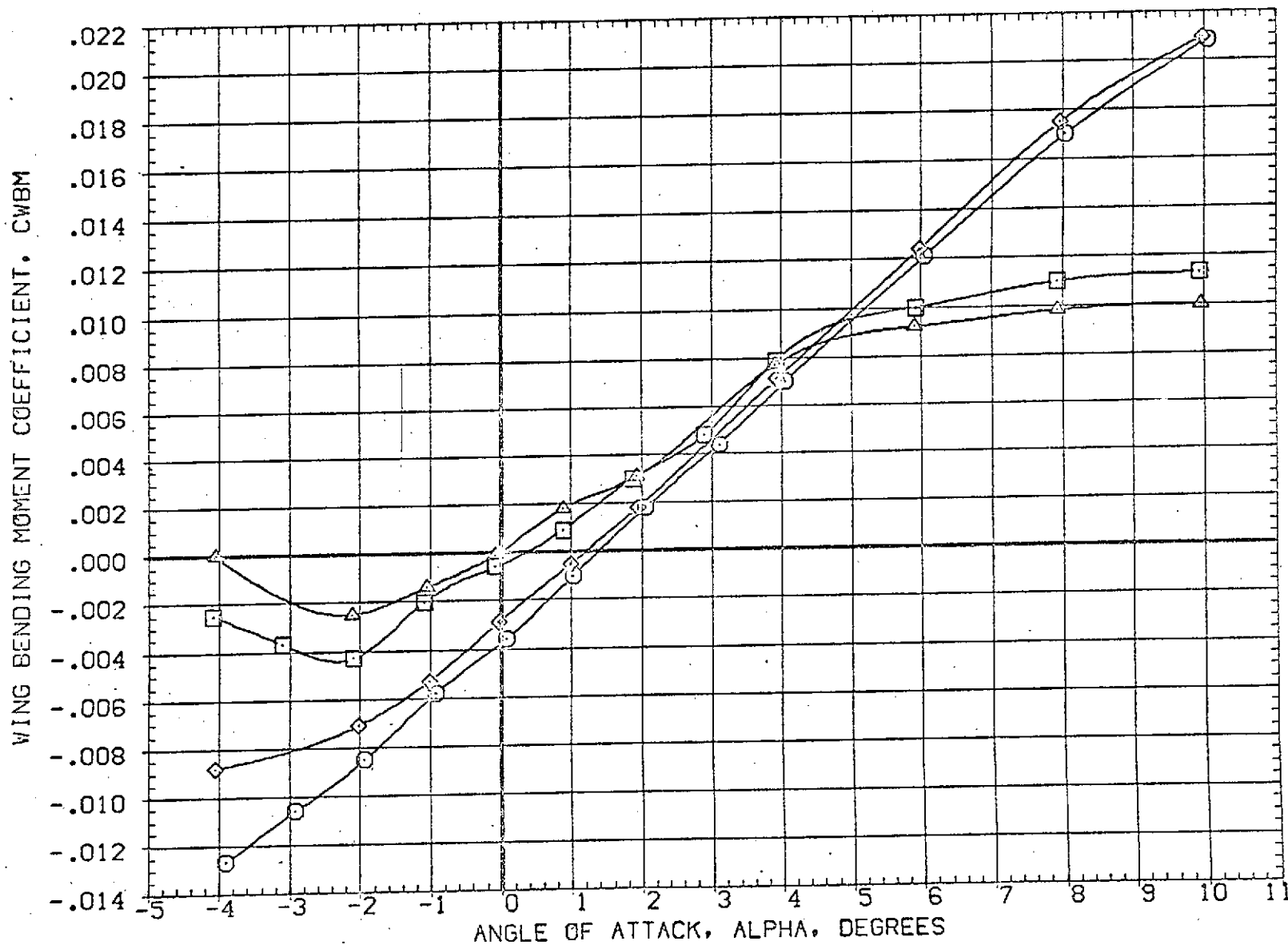

FIG 7 EFFECT OF PLUME SIZE ON LONGITUDINAL CHARACTERISTICS

(A)MACH = 1.60

DATA SET SYMBOL	CONFIGURATION DESCRIPTION	ELEVON	AILERON	RUDDER	PLUMES	REFERENCE INFORMATION		
(OB)501)	AMES 97-616 1A2 01 TO S1 NO PLUMES	.000	.000	.000	.000	SREF	3155.0000	50.FT.
(OB)001)	AMES 97-616 1A2 01 TO S1 PC/PT NOM. SRM A/A=8	.000	.000	.000	5.000	LREF	50.8000	FT.
(RB)007)	AMES 97-616 1A2 01 TO S1 SRM A/A=12.0RB NOM	.000	.000	.000	5.000	BREF	73.5000	FT.
(RB)009)	AMES 97-616 1A2 01 TO S1 PC/PT=1.3 NOMINAL	.000	.000	.000	5.000	XMRP	86.4157	FT.
						YMRP	.0000	FT.
						ZMRP	4.0000	FT.
						SCALE	.0190	

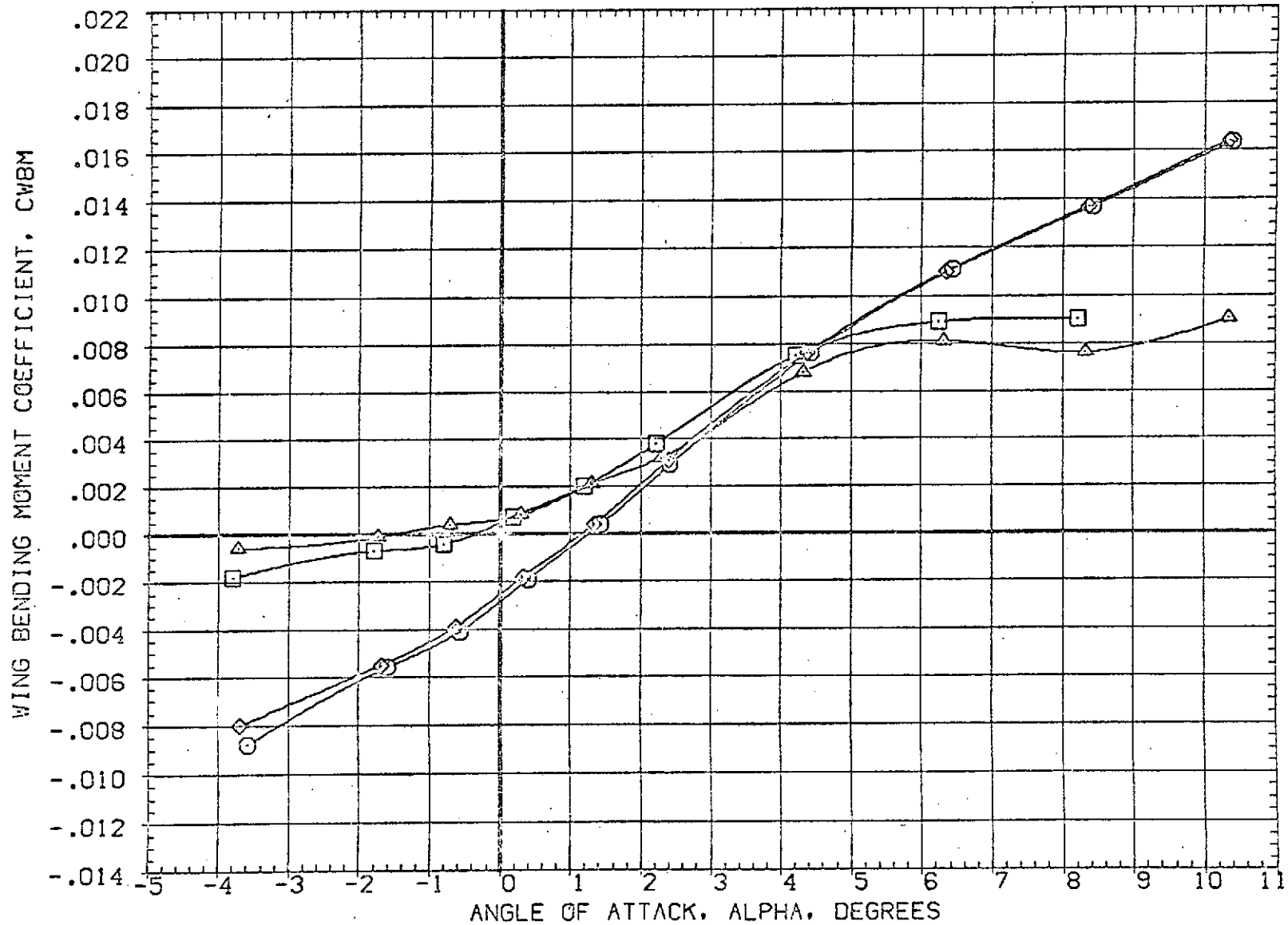

FIG 7 EFFECT OF PLUME SIZE ON LONGITUDINAL CHARACTERISTICS

(B)MACH = 1.98

DATA SET SYMBOL	CONFIGURATION DESCRIPTION	ELEVON	AILRON	RUDDER	PLUMES	REFERENCE INFORMATION	
(BBJ501)	AMES 97-616 1A2 01 TO S1 NO PLUMES	.000	.000	.000	.000	SREF	3155.0000 SQ.FT.
(BBJ001)	AMES 97-616 1A2 01 TO S1 PC/PT NOM, SRM A/A=8	.000	.000	.000	5.000	LREF	50.8000 FT.
(BBJ007)	AMES 97-616 1A2 01 TO S1 SRM A/A=12, ORB NOM	.000	.000	.000	5.000	BREF	73.5000 FT.
(BBJ009)	AMES 97-616 1A2 01 TO S1 PC/PT=1.3 NOMINAL	.000	.000	.000	5.000	XMRP	66.4167 FT.
						YMRP	.0000 FT.
						ZMRP	4.0000 FT.
						SCALE	.0190

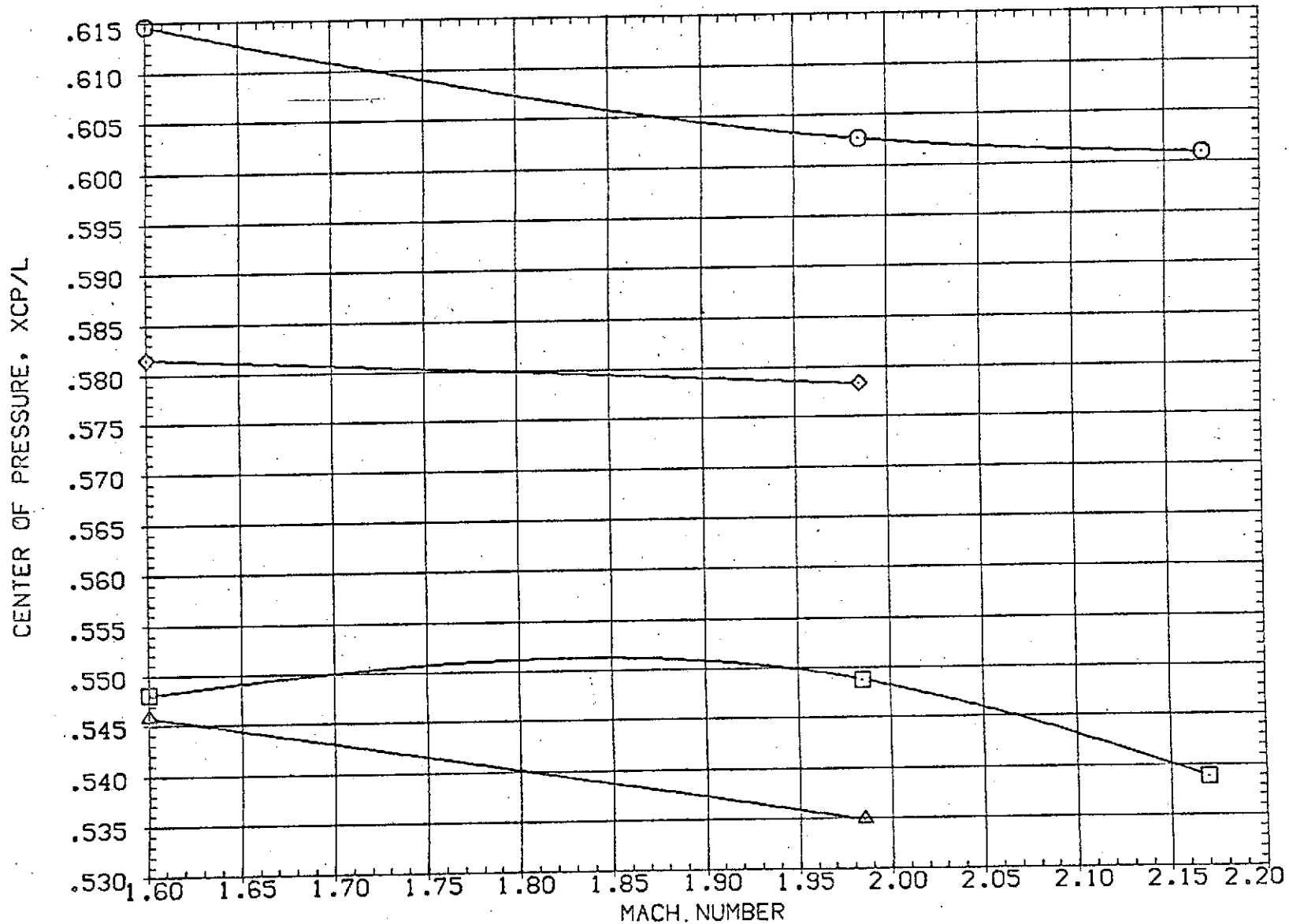

FIG 7 EFFECT OF PLUME SIZE ON LONGITUDINAL CHARACTERISTICS

DATA SET SYMBOL	CONFIGURATION DESCRIPTION										
(CBJ501)	AMES 97-616 1A2 01 TO S1 NO PLUMES	.000	.000	.000	.000	SREF	3155.0000	50. FT.			
(CBJ001)	AMES 97-616 1A2 01 TO S1 PC/PT NOM. SRM A/A=9	.000	.000	.000	5.000	LREF	50.8000	FT.			
(CBJ007)	AMES 97-616 1A2 01 TO S1 SRM A/A=12. CRB NOM	.000	.000	.000	5.000	BREF	73.5000	FT.			
(CBJ009)	AMES 97-616 1A2 01 TO S1 PC/PT=1.3 NOMINAL	.000	.000	.000	5.000	XMRP	86.4167	FT.			
						YMRP	.0000	FT.			
						ZMRP	4.0000	FT.			
						SCALE	.0190				

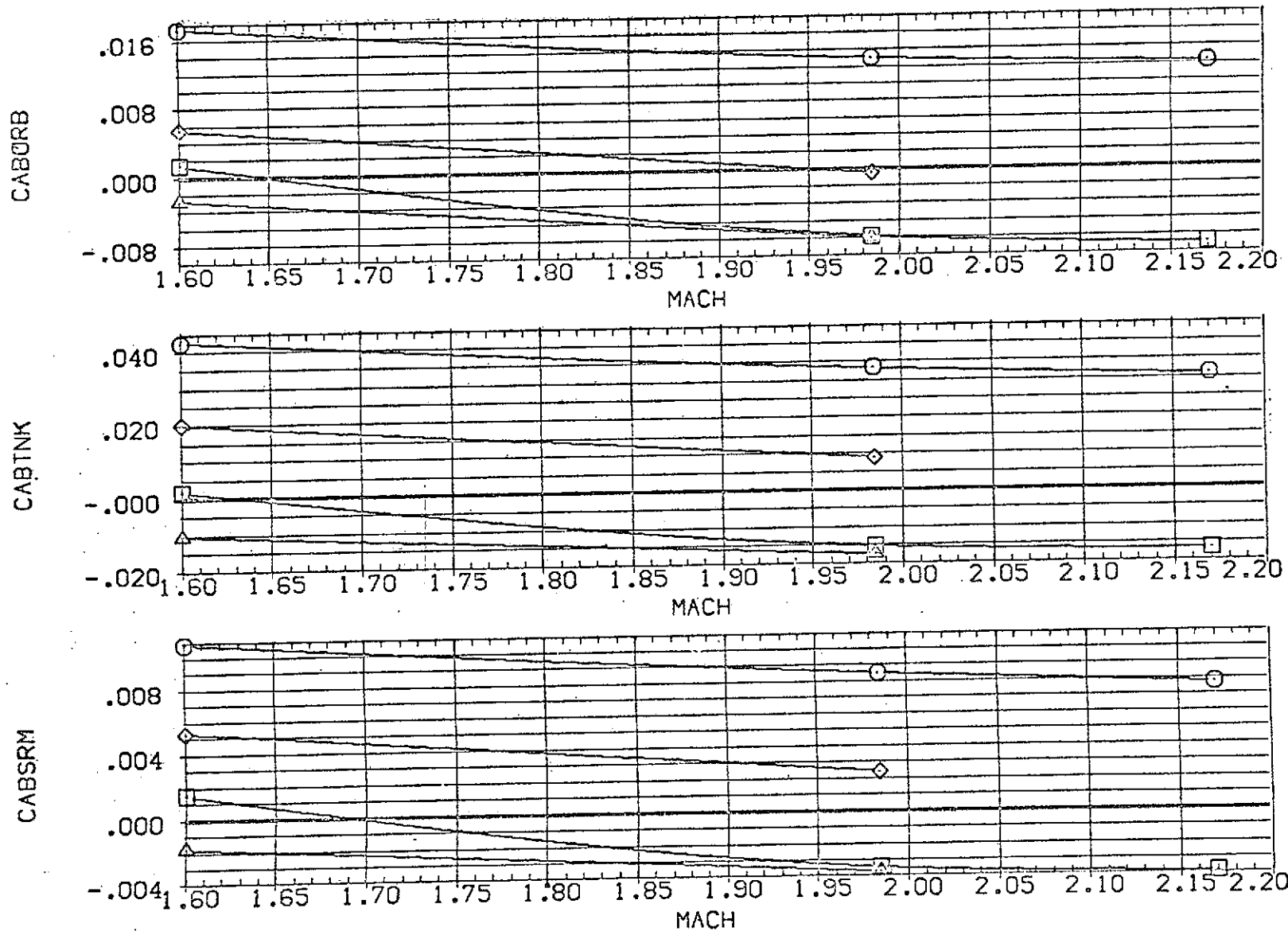

FIG 7 EFFECT OF PLUME SIZE ON LONGITUDINAL CHARACTERISTICS

DATA SET SYMBOL	CONFIGURATION DESCRIPTION	ELEVON	AILERON	RUDDER	PLUMES	REFERENCE INFORMATION
(02J502)	AMES 97-616 1A2 01 TO S1 NO PLUMES	.000	.000	.000	.000	SREF 3155.0000 SQ.FT.
(H3J002)	AMES 97-616 1A2 01 TO S1 PC/PT NOM. SRM A/A=8	.000	.000	.000	5.000	LREF 50.8000 FT.
(R2J008)	AMES 97-616 1A2 01 TO S1 SRM A/A=12.0RB NOM	.000	.000	.000	5.000	BREF 73.5000 FT.
(R3J010)	AMES 97-616 1A2 01 TO S1 PC/PT=1.3 NOMINAL	.000	.000	.000	5.000	XMRP 86.4167 FT. YMRP .0000 FT. ZMRP 4.0000 FT. SCALE .0120

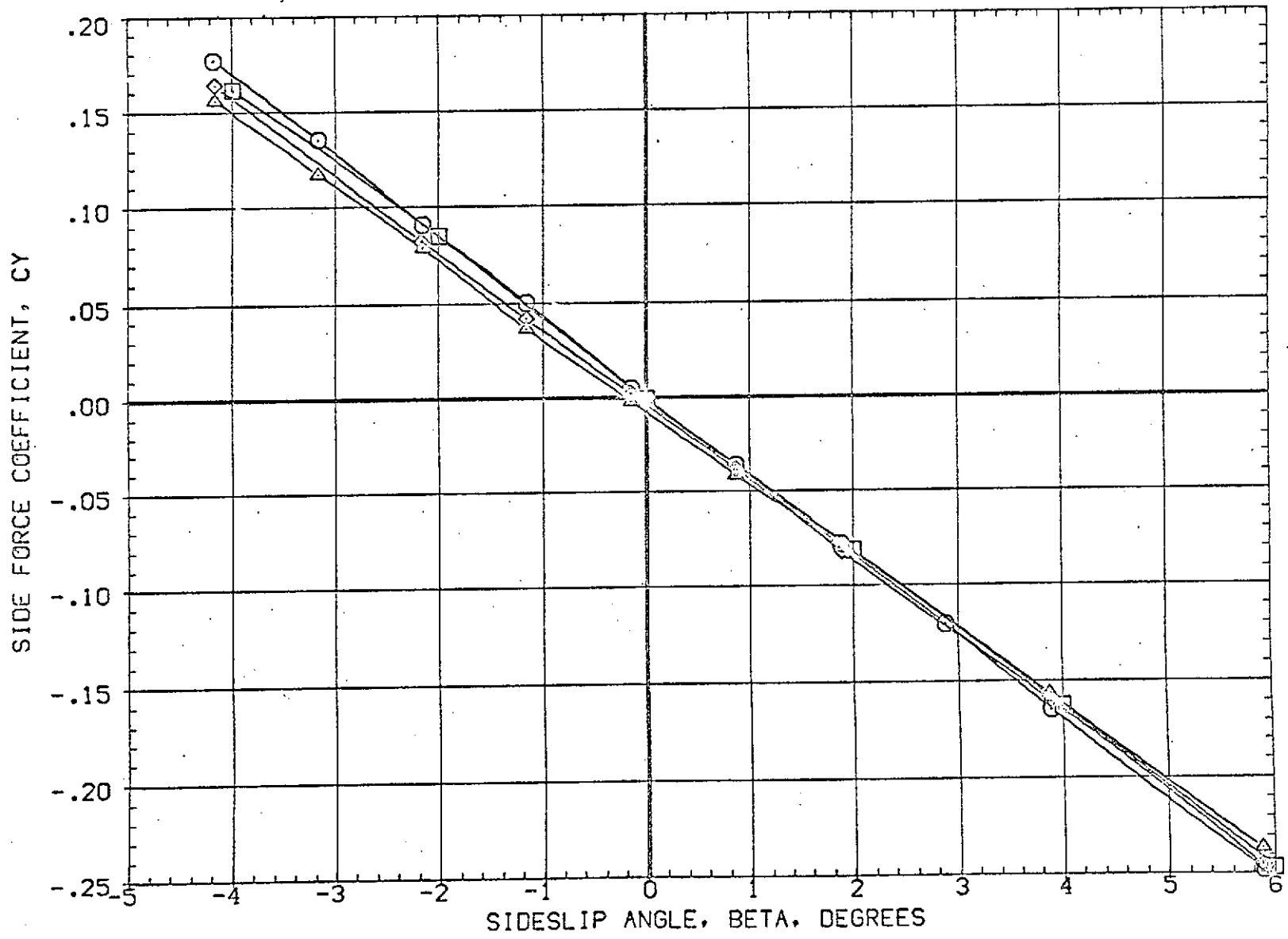

FIG 8 EFFECT OF PLUME SIZE ON LATERAL CHARACTERISTICS, ALPHA=0.0

(A)MACH = 1.60

DATA SET SYMBOL	CONFIGURATION DESCRIPTION	ELEVON	AILRON	RUDDER	PLUMES	REFERENCE INFORMATION		
(DBJ502)	AMES 97-616 1A2 01 TO S1 NO PLUMES	.000	.000	.000	.000	SREF	3155.0000	SQ.FT.
(HBJ002)	AMES 97-616 1A2 01 TO S1 PC/PT NOM, SRM A/A=8	.000	.000	.000	5.000	LREF	50.8000	FT.
(RBJ008)	AMES 97-616 1A2 01 TO S1 SRM A/A=12, CR8 NOM	.000	.000	.000	5.000	BREF	73.5000	FT.
(RBJ010)	AMES 97-616 1A2 01 TO S1 PC/PT=1.3 NOMINAL	.000	.000	.000	5.000	XMRP	86.4167	FT.
						YMRP	.0000	FT.
						ZMRP	4.0000	FT.
						SCALE	.0190	

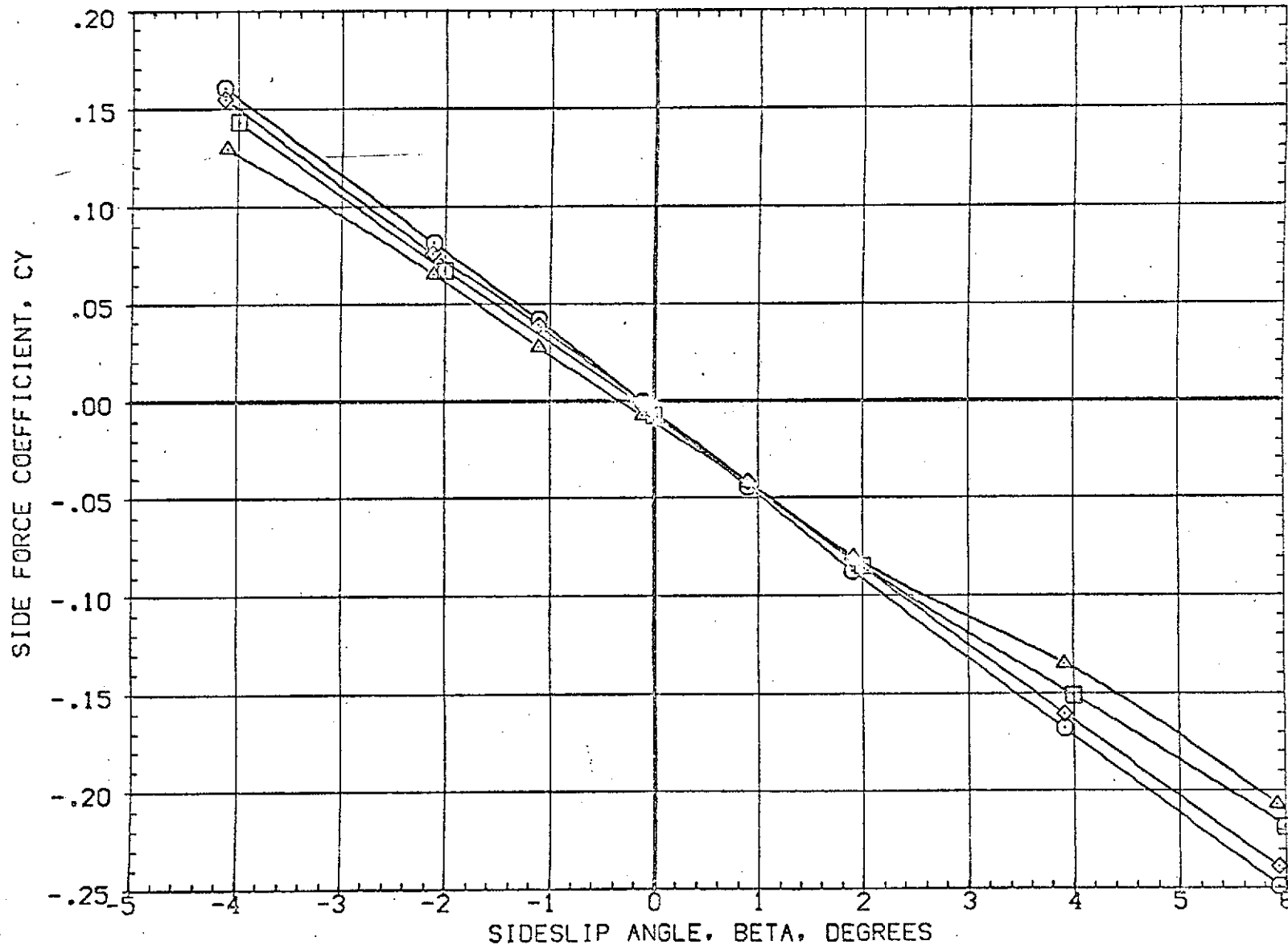

FIG 8 EFFECT OF PLUME SIZE ON LATERAL CHARACTERISTICS, ALPHA=0.0

(B)MACH = 1.98

DATA SET SYMBOL	CONFIGURATION DESCRIPTION	ELEVON	AILRON	RUDDER	PLUMES	REFERENCE INFORMATION
(OBJ502)	AMCS 97-616 IA2 01 TO S1 NO PLUMES	.000	.000	.000	.000	SREF 3155.0000 SQ.FT.
(OBJ002)	AMCS 97-616 IA2 01 TO S1 PC/PT NOM. SRM A/A=8	.000	.000	.000	5.000	LREF 50.8000 FT.
(RBJ008)	AMCS 97-616 IA2 01 TO S1 SRM A/A=12.0RB NOM	.000	.000	.000	5.000	BREF 73.5000 FT.
(RBJ010)	AMCS 97-616 IA2 01 TO S1 PC/PT=1.3 NOMINAL	.000	.000	.000	5.000	XMRP 86.4167 FT. YMRP .0000 FT. ZMRP 4.0000 FT. SCALE .0190

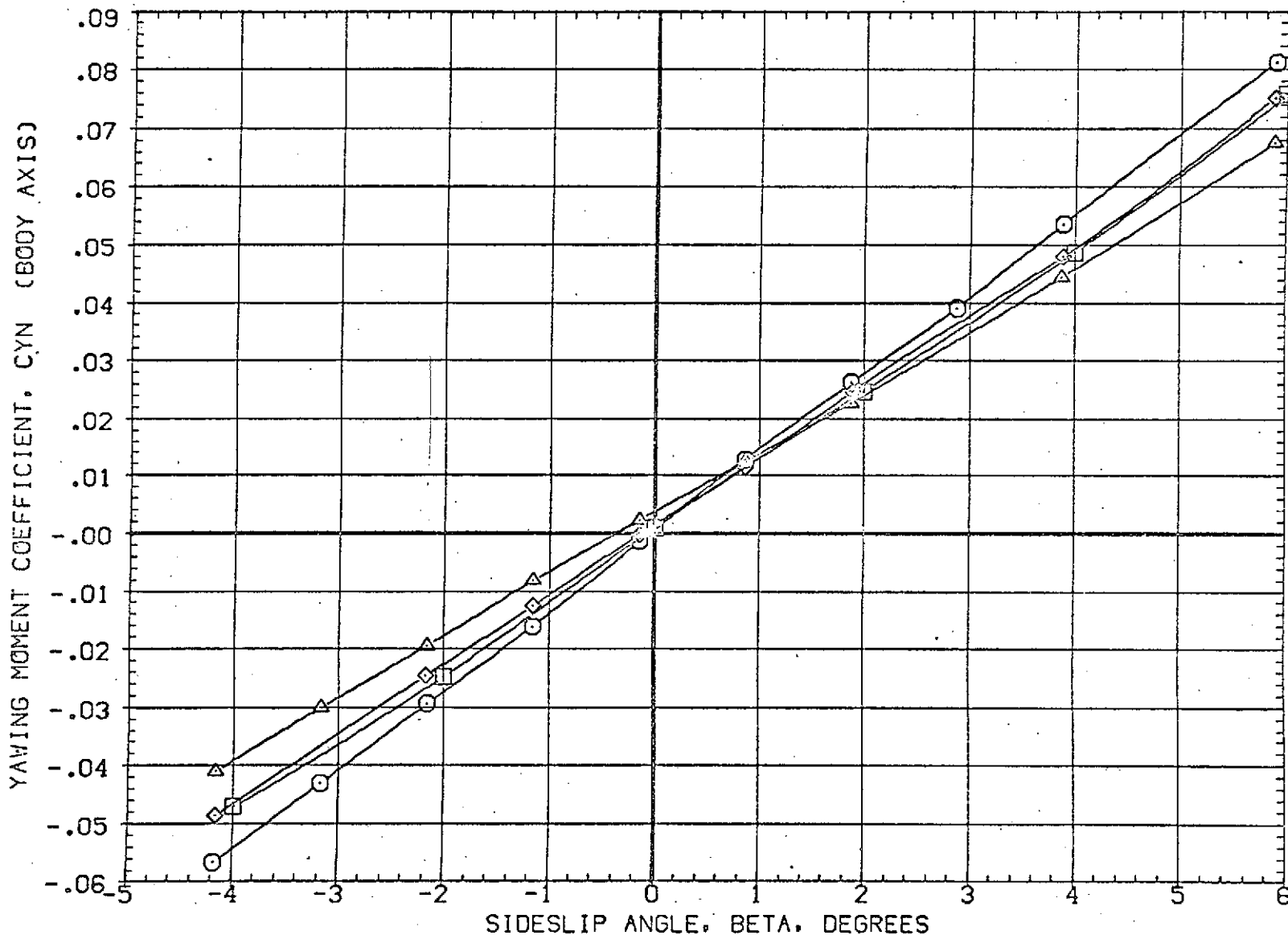

FIG 8 EFFECT OF PLUME SIZE ON LATERAL CHARACTERISTICS, ALPHA=0.0

(A)MACH = 1.60

DATA SET	SYMBOL	CONFIGURATION DESCRIPTION	ELEVON	AILERON	RUDDER	PLUMES	REFERENCE INFORMATION		
(DBJS02)	○	AMES 97-616 1A2 01 TO S1 NO PLUMES	.000	.000	.000	.000	SREF	3155.0000	50. FT.
(HSJ002)	□	AMES 97-616 1A2 01 TO S1 PC/PT NOM. SRM A/A=8	.000	.000	.000	5.000	LREF	50.8000	FT.
(RBJ008)	◇	AMES 97-616 1A2 01 TO S1 SRM A/A=12.0RB NOM	.000	.000	.000	5.000	BREF	73.5000	FT.
(RBJ010)	△	AMES 97-616 1A2 01 TO S1 PC/PT=1.3 NOMINAL	.000	.000	.000	5.000	XMRP	96.4167	FT.
							YMRP	.0000	FT.
							ZMRP	4.0000	FT.
							SCALE	.0190	

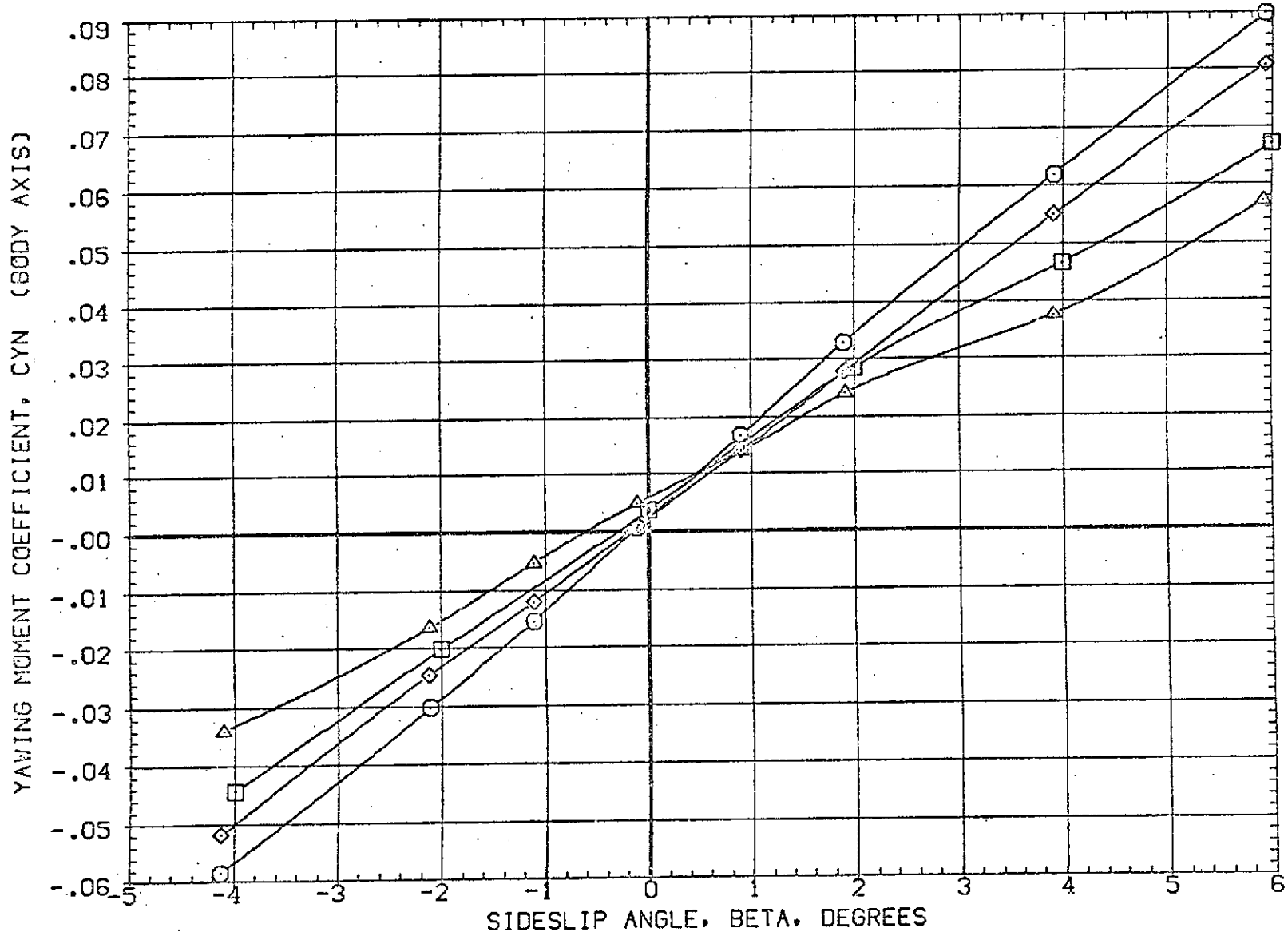

FIG 8 EFFECT OF PLUME SIZE ON LATERAL CHARACTERISTICS, ALPHA=0.0

(B)MACH = 1.98

DATA SET SYMBOL	CONFIGURATION DESCRIPTION	ELEVON	AILRON	RUDDER	PLUMES	REFERENCE INFORMATION		
(DBJ502)	AMES 97-616 1A2 01 TO S1 NO PLUMES	.000	.000	.000	.000	SREF	3155.0000	50.FT.
(RBJ002)	AMES 97-616 1A2 01 TO S1 PC/PT NOM, SRM A/A=8	.000	.000	.000	5.000	LREF	50.8000	FT.
(RBJ008)	AMES 97-616 1A2 01 TO S1 SRM A/A=12.0RB NOM	.000	.000	.000	5.000	BREF	73.5000	FT.
(RBJ010)	AMES 97-616 1A2 01 TO S1 PC/PT=1.3 NOMINAL	.000	.000	.000	5.000	XMRP	66.4167	FT.
						YMRP	.0000	FT.
						ZMRP	4.0000	FT.
						SCALE	.0190	

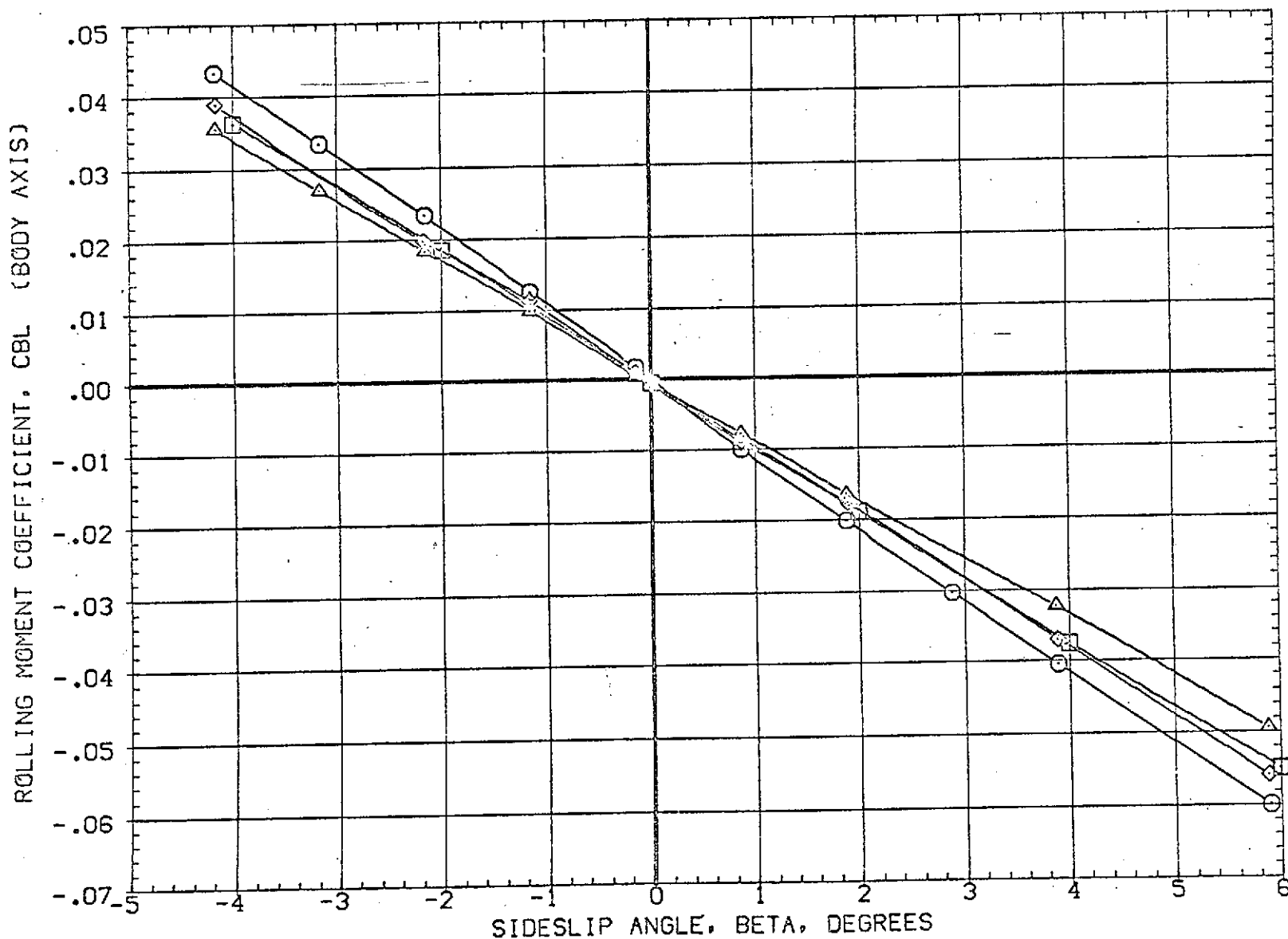

FIG 8 EFFECT OF PLUME SIZE ON LATERAL CHARACTERISTICS, ALPHA=0.0

(A)MACH = 1.60

DATA SET SYMBOL	CONFIGURATION DESCRIPTION	ELEVON	AILERON	RUDDER	PLUMES	REFERENCE INFORMATION		
(DBJ502)	AMES 97-616 1A2 01 TO S1 NO PLUMES	.000	.000	.000	.000	SREF	3155.0000	SQ.FT.
(DBJ002)	AMES 97-616 1A2 01 TO S1 PC/PT NOM, SRM A/A=8	.000	.000	.000	5.000	LREF	50.8000	FT.
(R2J003)	AMES 97-616 1A2 01 TO S1 SRM A/A=12.0RB NOM	.000	.000	.000	5.000	BREF	73.5000	FT.
(R2J010)	AMES 97-616 1A2 01 TO S1 PC/PT=1.3 NOMINAL	.000	.000	.000	5.000	XMYP	86.4167	FT.
						YMYP	.0000	FT.
						ZMYP	4.0000	FT.
						SCALE	.0190	

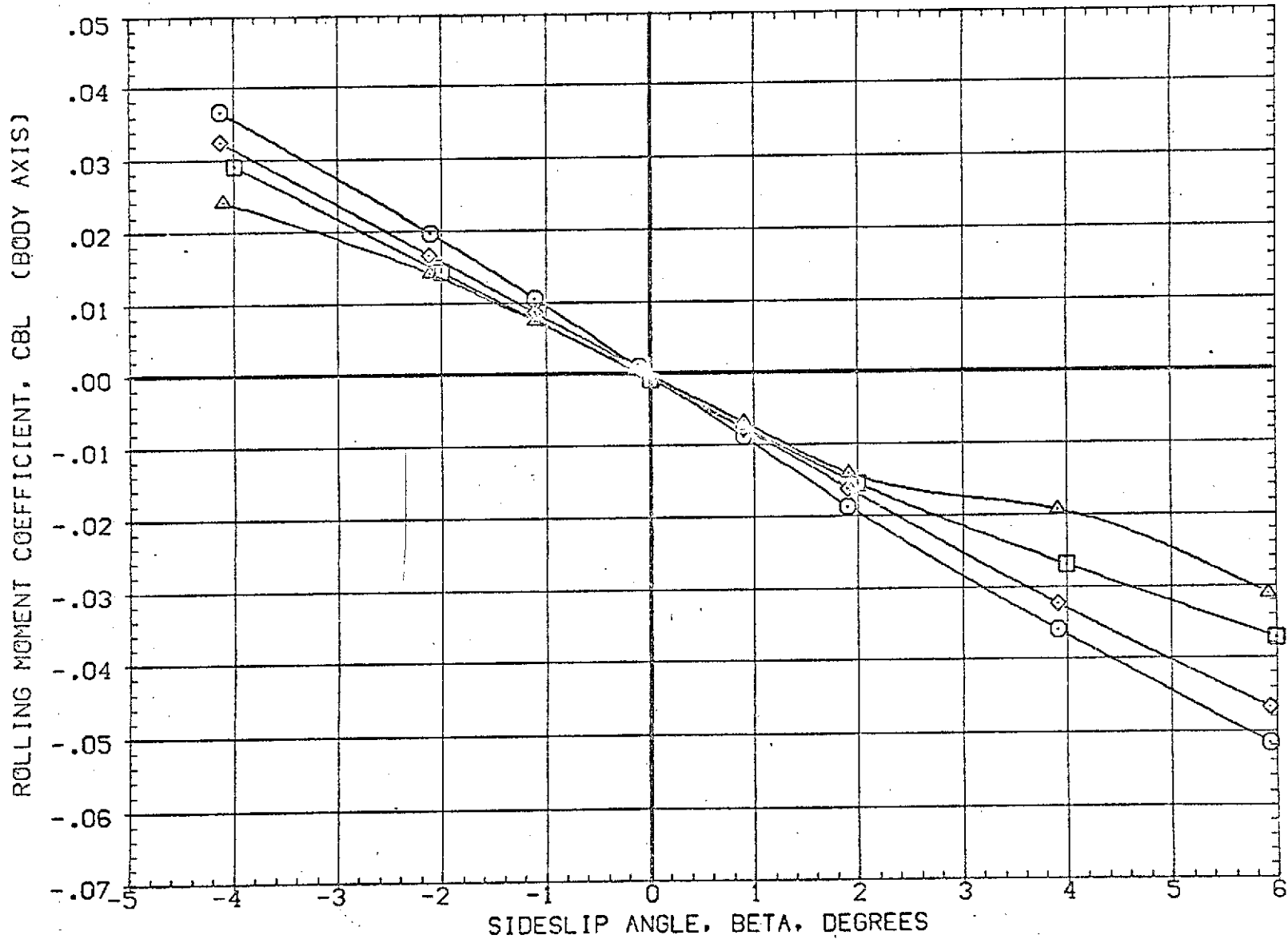

FIG 8 EFFECT OF PLUME SIZE ON LATERAL CHARACTERISTICS, ALPHA=0.0

(B)MACH = 1.98

DATA SET SYMBOL	CONFIGURATION DESCRIPTION	ELEVON	AILERON	RUDDER	PLUMES	REFERENCE INFORMATION
(DBJ502)	AMES 97-616 1A2 01 TO S1 NO PLUMES	.000	.000	.000	.000	SREF 3155.0000 SQ.FT.
(HBJ002)	AMES 97-616 1A2 01 TO S1 PC/PT NOM. SRM A/A=8	.000	.000	.000	5.000	LREF 50.8000 FT.
(RBJ008)	AMES 97-616 1A2 01 TO S1 SRM A/A=12. DRB NOM	.000	.000	.000	5.000	BREF 73.5000 FT.
(RBJ010)	AMES 97-616 1A2 01 TO S1 PC/PT=1.3 NOMINAL	.000	.000	.000	5.000	XMRP 86.4167 FT. YMRP .0000 FT. ZMRP 4.0000 FT. SCALE .0190

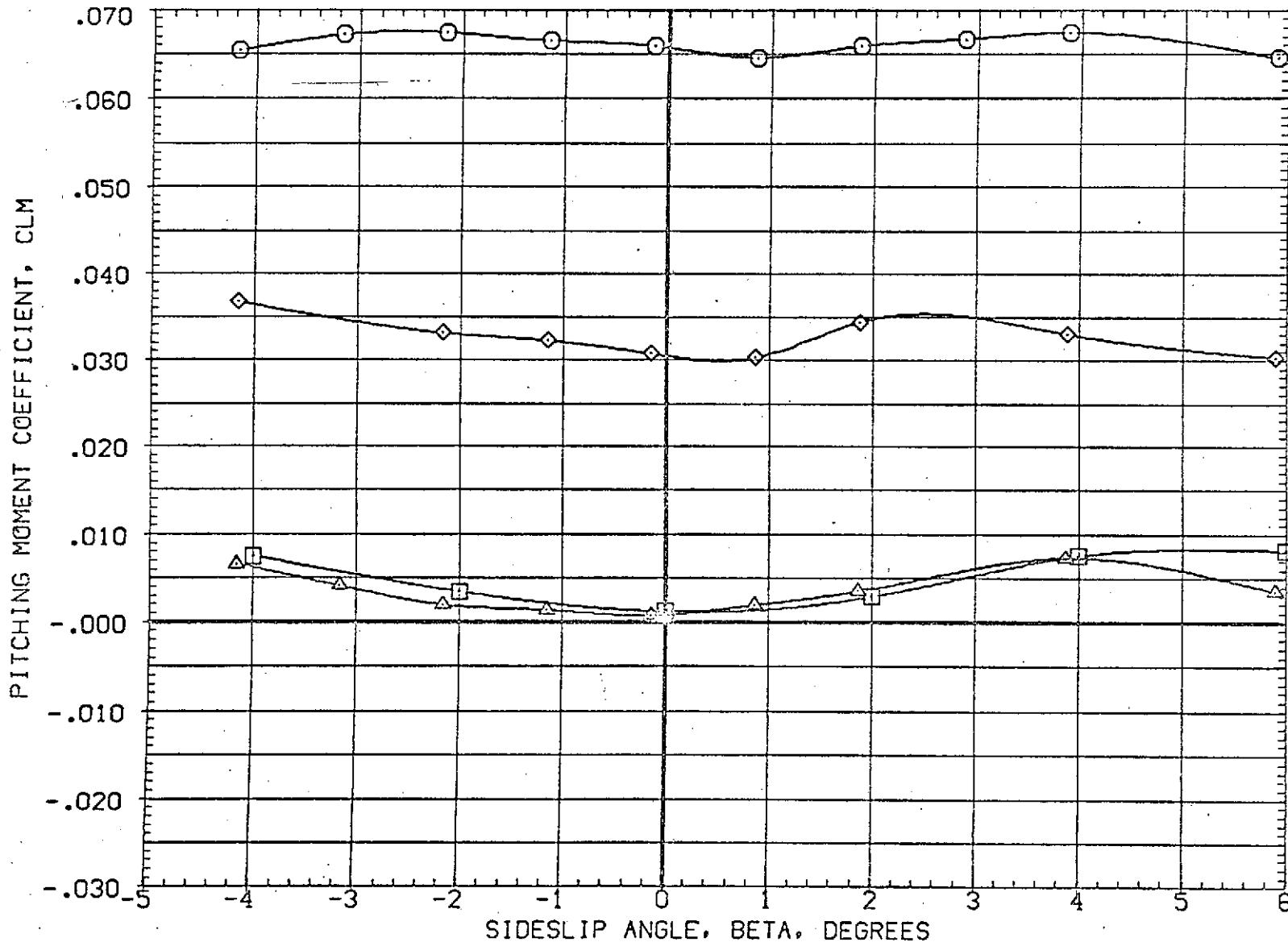

FIG 8 EFFECT OF PLUME SIZE ON LATERAL CHARACTERISTICS, ALPHA=0.0

(A)MACH = 1.60

DATA SET SYMBOL	CONFIGURATION DESCRIPTION	ELEVON	AILERON	HULLER	PLUMES	REFERENCE QUANTITY
(DBJ502)	AMES 97-616 IA2 01 TO S1 NO PLUMES	.000	.000	.000	.000	SREF 3155.0000 SQ.FT.
(DBJ002)	AMES 97-616 IA2 01 TO S1 PC/PT NOM. SRM A/A=8	.000	.000	.000	5.000	LREF 50.8000 FT.
(RBJ008)	AMES 97-616 IA2 01 TO S1 SRM A/A=12.0RB NOM	.000	.000	.000	5.000	BREF 73.5000 FT.
(RBJ010)	AMES 97-616 IA2 01 TO S1 PC/PT=1.3 NOMINAL	.000	.000	.000	5.000	XMRP 86.4167 FT.
						YMRP .0000 FT.
						ZMRP 4.0000 FT.
						SCALE .0190

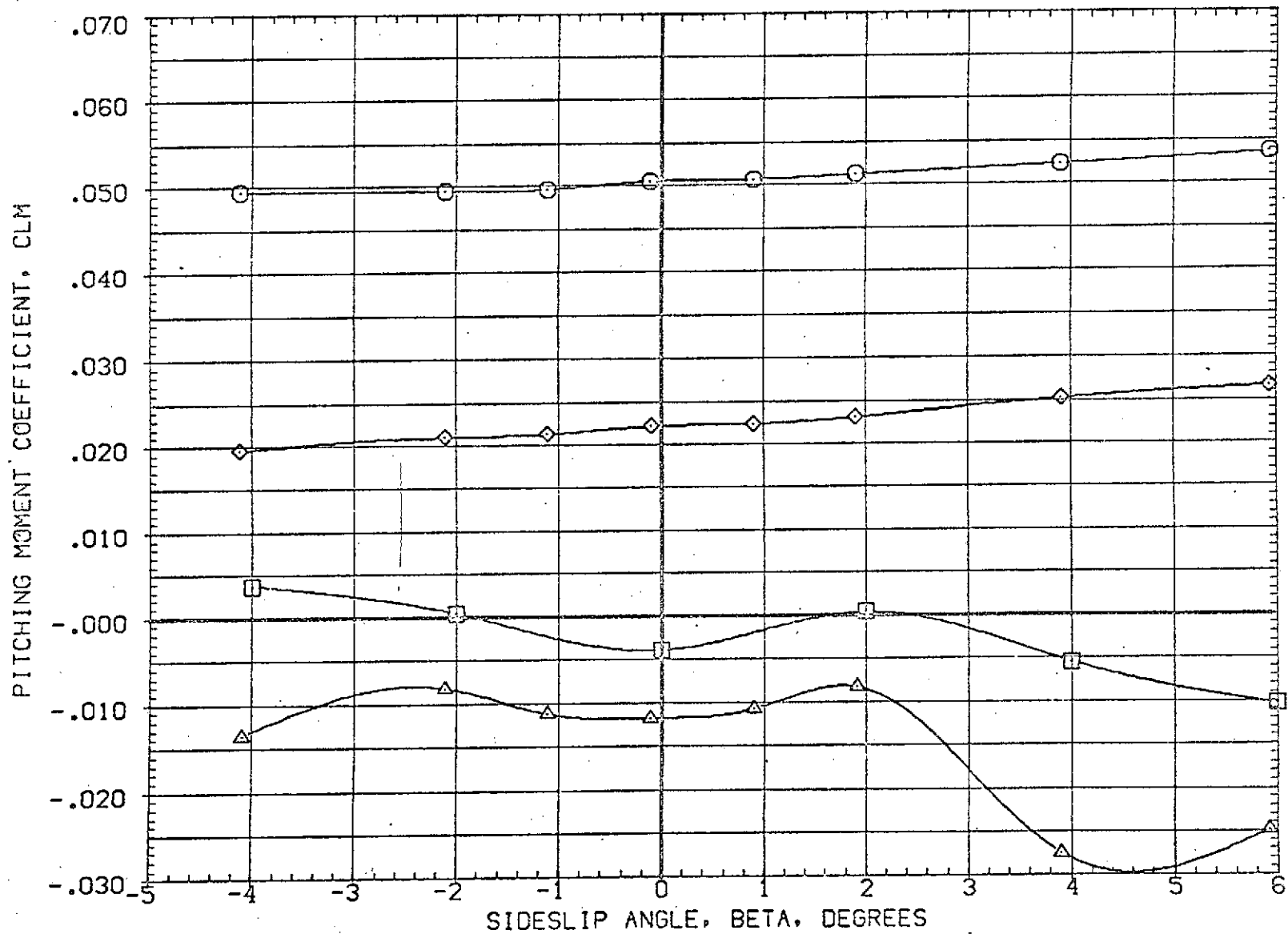

FIG 8 EFFECT OF PLUME SIZE ON LATERAL CHARACTERISTICS, ALPHA=0.0

(B)MACH = 1.98

DATA SET SYMBOL	CONFIGURATION DESCRIPTION	ELEVON	AILRON	RUDDER	PLUMES	REFERENCE INFORMATION		
(DBJ502)	AMES 97-616 IA2 01 TO S1 NO PLUMES	.000	.000	.000	.000	SREF	3155.0000	50.FT.
(HBJ002)	AMES 97-616 IA2 01 TO S1 PC/PT NOM, SRM A/A=8	.000	.000	.000	5.000	LREF	50.8000	FT.
(RBJ008)	AMES 97-616 IA2 01 TO S1 SRM A/A=12, GRB NOM	.000	.000	.000	5.000	BREF	73.5000	FT.
(RBJ010)	AMES 97-616 IA2 01 TO S1 PC/PT=1.3 NOMINAL	.000	.000	.000	5.000	XMRP	86.4167	FT.
						YMRP	.0000	FT.
						ZMRP	4.0000	FT.
						SCALE	.0190	

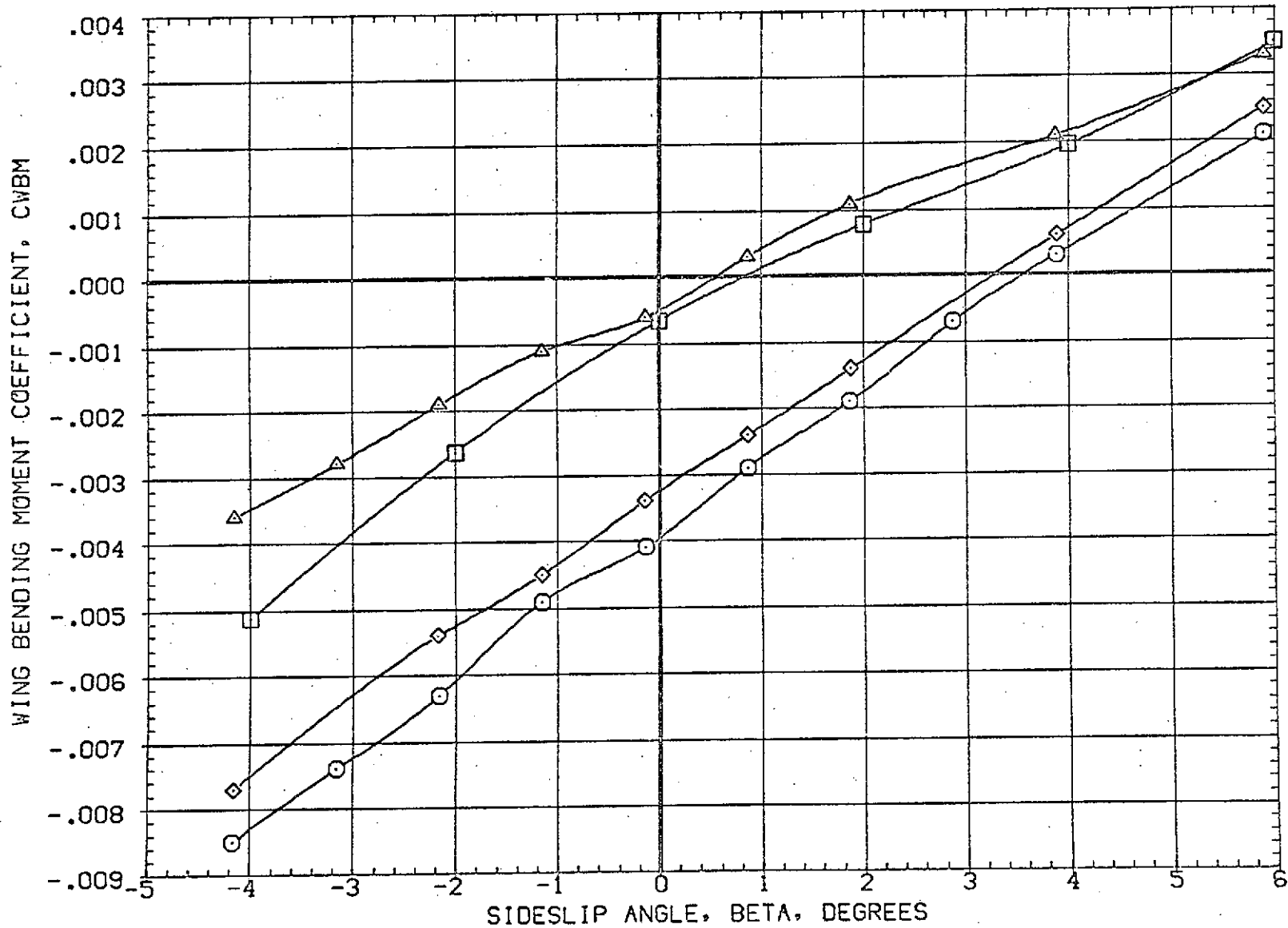

FIG 8 EFFECT OF PLUME SIZE ON LATERAL CHARACTERISTICS, ALPHA=0.0

(A)MACH = 1.60

DATA SET SYMBOL	CONFIGURATION DESCRIPTION
(DBJ502)	AMES 97-616 1A2 01 TO S1 NO PLUMES
(RBJ002)	AMES 97-616 1A2 C1 TO S1 PC/PT NOM. SRM A/A=8
(RBJ008)	AMES 97-616 1A2 01 TO S1 SRM A/A=12.0RB NOM
(RBJ010)	AMES 97-616 1A2 01 TO S1 PC/PT=1.3 NOMINAL

ELEVON	AILRON	RUDDER	PLUMES	REFERENCE INFORMATION
.000	.000	.000	.000	SREF 3155.0000 SQ.FT.
.000	.000	.000	5.000	LREF 50.8000 FT.
.000	.000	.000	5.000	BREF 73.5000 FT.
.000	.000	.000	5.000	XMRP 86.4167 FT.
				YMRP .0000 FT.
				ZMRP 4.0000 FT.
				SCALE .0190

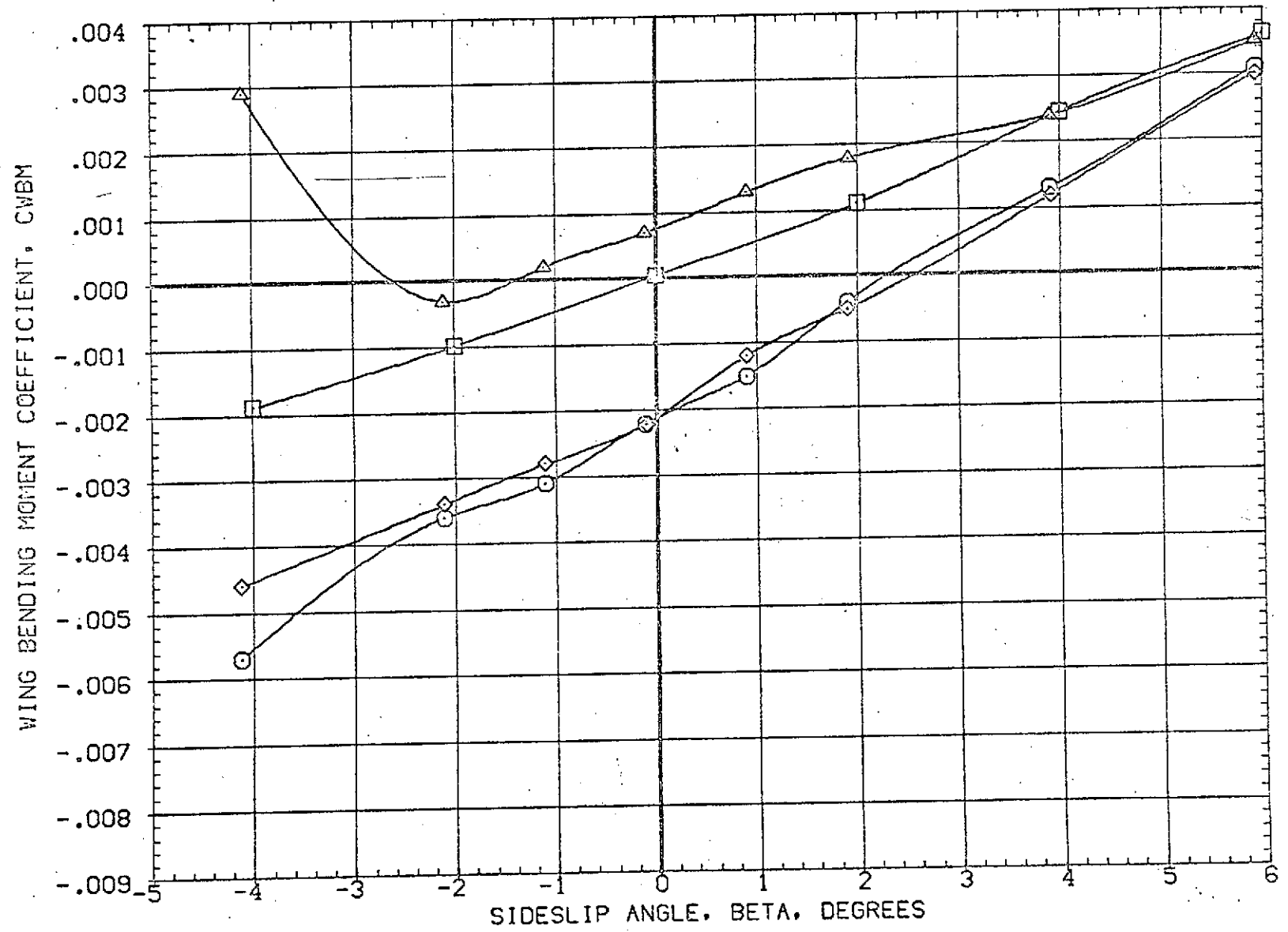

FIG 8 EFFECT OF PLUME SIZE ON LATERAL CHARACTERISTICS, ALPHA=0.0

(B)MACH = 1.98

DATA SET SYMBOL	CONFIGURATION DESCRIPTION	ELEVON	AILRON	RUDDER	PLUMES	REFERENCE INFORMATION		
(EBJ001)	AMES 97-616 [A2 01 TO S1 PC/PT NOM. SRM A/A=8	.000	.000	.000	5.000	SREF	3155.0000	50. FT.
(RBJ031)	AMES 97-616 [A2 01 TO S1 M=.9 NOZ. PC/PT=.82 NOM	.000	.000	.000	2.000	LREF	50.8000	FT.
(RBJ032)	AMES 97-616 [A2 01 TO S1 M=.9 NOZ. PC/PT=1.1 NOM	.000	.000	.000	2.000	BREF	73.5000	FT.
(RBJ033)	AMES 97-616 [A2 01 TO S1 M=3.0 NOZ. PC/PT=NOM	.000	.000	.000	2.000	XMRP	86.4167	FT.
(RBJ034)	AMES 97-616 [A2 01 TO S1 M=3.0 NOZ. PC/PT=1.2 NOM	.000	.000	.000	2.000	YMRP	.0000	FT.
(RBJ035)	AMES 97-616 [A2 01 TO S1 M=3.0 NOZ. PC/PT=0.8 NOM	.000	.000	.000	2.000	ZMRP	4.0000	FT.
						SCALE	.0190	

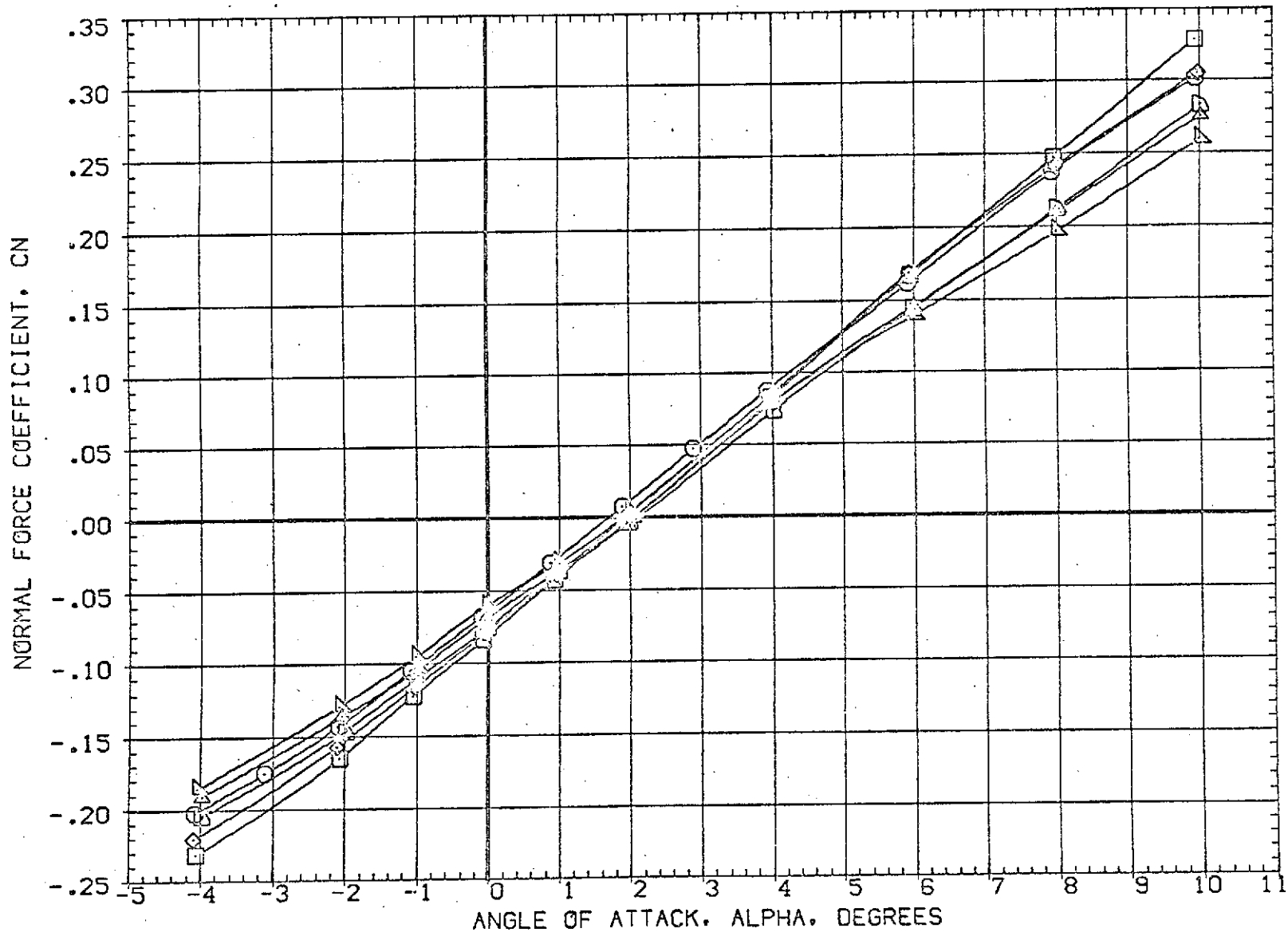

FIG 9 EFFECT OF NOZZLE DESIGN POINT ON LONGITUDINAL CHARACTERISTICS

(A) MACH = 1.60

DATA SET SYMBOL	CONFIGURATION DESCRIPTION	ELEVON	AILEON	RUDDER	FLAPS	SREF	REFERENCE TO ORIGIN
(RBJ001)	AMES 97-616 1A2 01 TO S1 PC/PT NOM, SRM A/A=8	.000	.000	.000	5.000	3155.0000	50. FT.
(RBJ031)	AMES 97-616 1A2 01 TO S1 M=.9, NOZ, PC/PT=.82 NOM	.000	.000	.000	2.000	LREF	50.8000 FT.
(RBJ032)	AMES 97-616 1A2 01 TO S1 M=.9 NOZ, PC/PT=1.1 NOM	.000	.000	.000	2.000	BREF	73.5000 FT.
(RBJ033)	AMES 97-616 1A2 01 TO S1 M=3.0 NOZ, PC/PT=NOM	.000	.000	.000	2.000	XMRP	85.4157 FT.
(RBJ034)	AMES 97-616 1A2 01 TO S1 M=3.0 NOZ, PC/PT=1.2 NOM	.000	.000	.000	2.000	YMRP	.0000 FT.
(RBJ035)	AMES 97-616 1A2 01 TO S1 M=3.0 NOZ, PC/PT=0.8 NOM	.000	.000	.000	2.000	ZMRP	4.0000 FT.
						SCALE	.0190

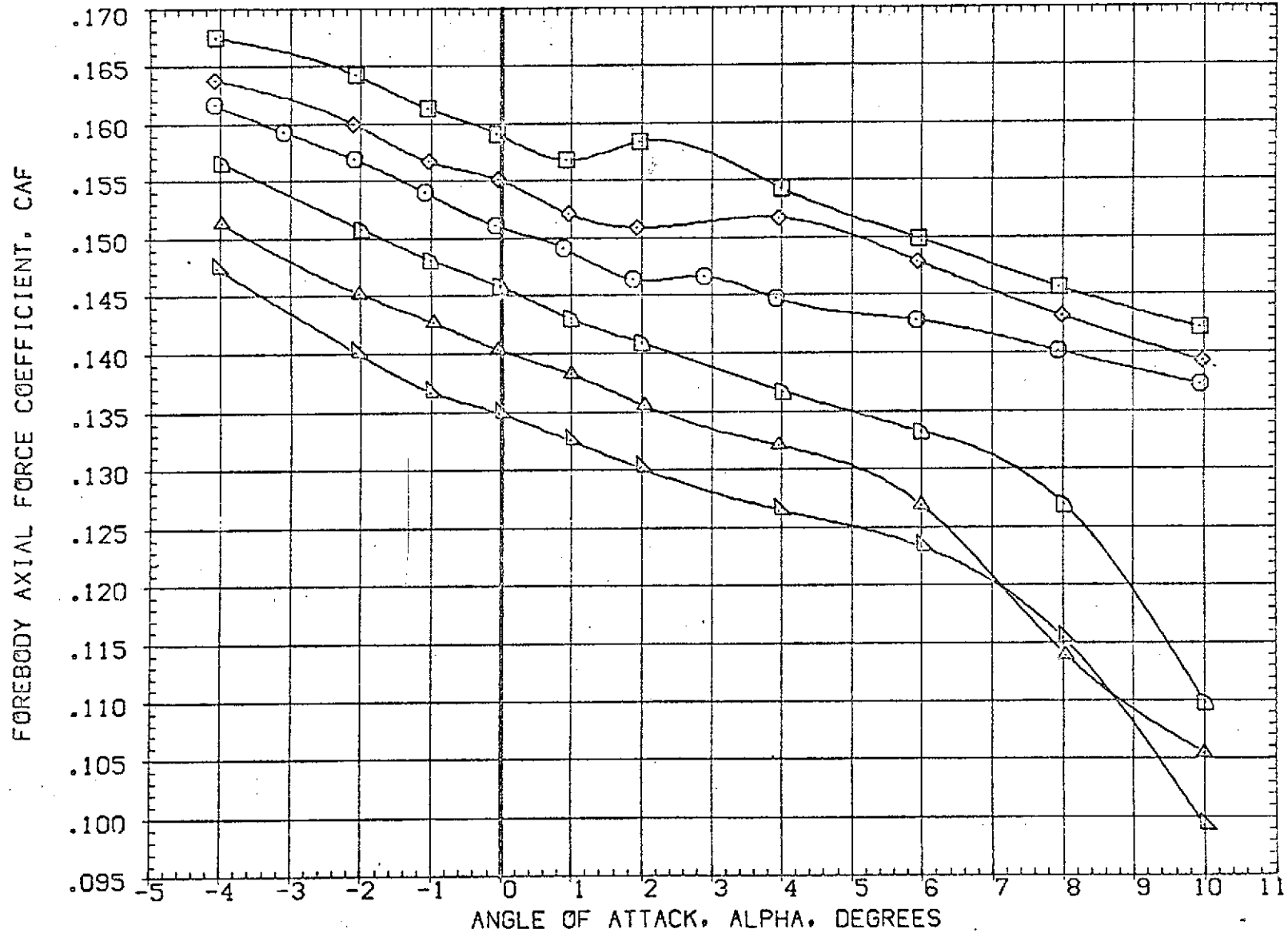

FIG 9 EFFECT OF NOZZLE DESIGN POINT ON LONGITUDINAL CHARACTERISTICS

(A) MACH = 1.60

DATA SET SYMBOL	CONFIGURATION DESCRIPTION	ELEVON	AILERON	RUDDER	PLUMES	REFERENCE INFORMATION		
(RBJ001)	AMES 97-616 1A2 01 TO S1 PC/PT NOM. SRM A/A=8	.000	.000	.000	5.000	SREF	3155.0000	SQ.FT.
(RBJ031)	AMES 97-616 1A2 01 TO S1 M=.9 NOZ.PC/PT=.82 NOM	.000	.000	.000	2.000	LREF	50.8000	FT.
(RBJ032)	AMES 97-616 1A2 01 TO S1 M=.9 NOZ.PC/PT=1.1 NOM	.000	.000	.000	2.000	BREF	73.5000	FT.
(RBJ033)	AMES 97-616 1A2 01 TO S1 M=3.0 NOZ.PC/PT=NOM	.000	.000	.000	2.000	XMRP	85.4167	FT.
(RBJ034)	AMES 97-616 1A2 01 TO S1 M=3.0 NOZ.PC/PT=1.2 NOM	.000	.000	.000	2.000	YMRP	.0000	FT.
(RBJ035)	AMES 97-616 1A2 01 TO S1 M=3.0 NOZ.PC/PT=0.8 NOM	.000	.000	.000	2.000	ZMRP	4.0000	FT.
						SCALE	.0190	

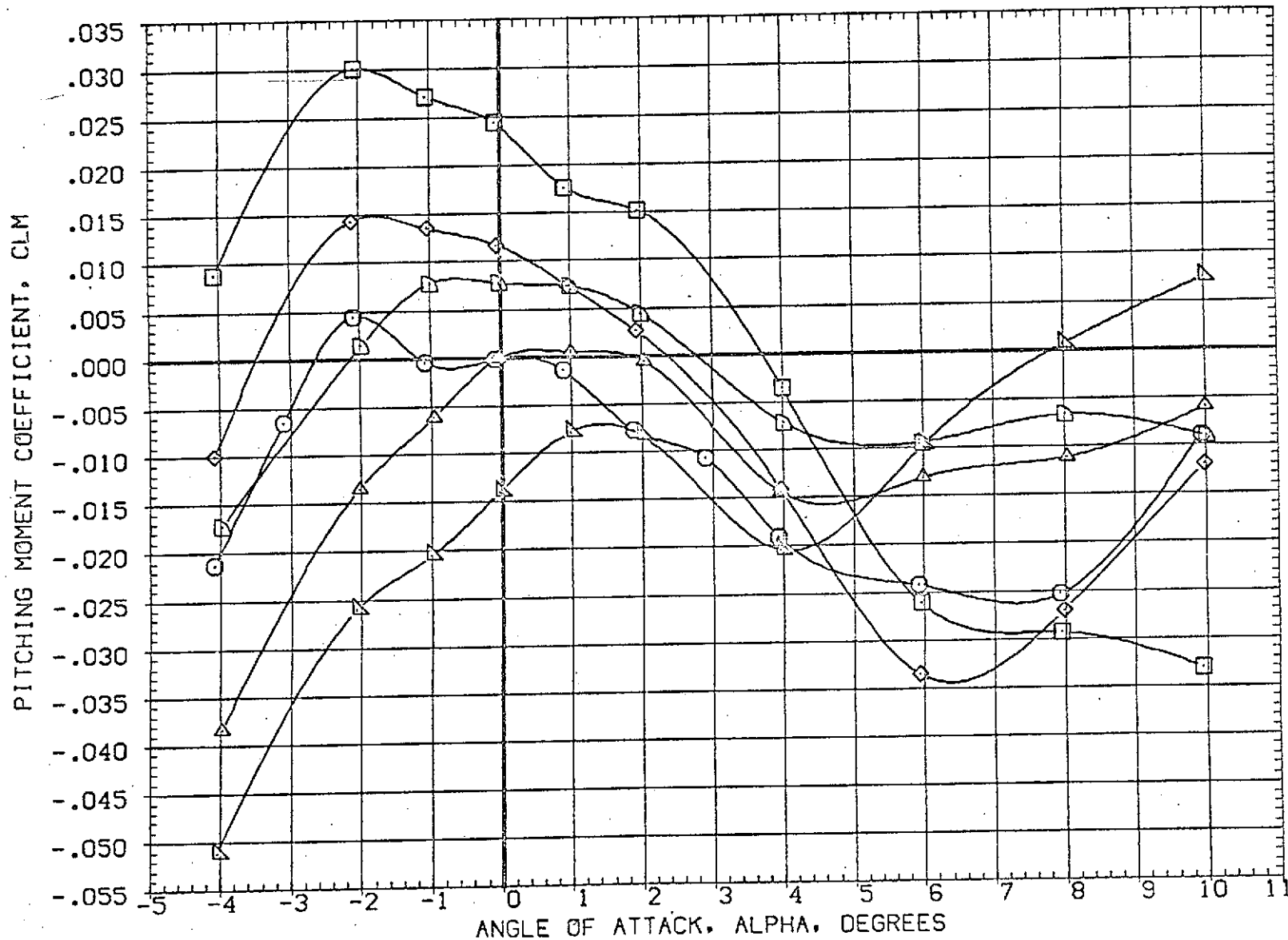

FIG 9 EFFECT OF NOZZLE DESIGN POINT ON LONGITUDINAL CHARACTERISTICS

(A) MACH = 1.60

DATA SET SYMBOL	CONFIGURATION DESCRIPTION	ELEVON	AILERON	RUDDER	PLUMES	REFERENCE INFORMATION
(EBJ001)	AMES 97-616 1A2 01 TO S1 PC/PT NOM.SRM A/A=8	.000	.000	.000	5.000	SREF 3155.0000 SQ.FT.
(RBJ031)	AMES 97-616 1A2 01 TO S1 M=.9 NOZ,PC/PT=.82 NOM	.000	.000	.000	2.000	LREF 50.8000 FT.
(RBJ032)	AMES 97-616 1A2 01 TO S1 M=.9 NOZ,PC/PT=1.1 NOM	.000	.000	.000	2.000	BREF 73.5000 FT.
(RBJ033)	AMES 97-616 1A2 01 TO S1 M=3.0 NOZ,PC/PT=NOM	.000	.000	.000	2.000	XMRP 86.4167 FT.
(RBJ034)	AMES 97-616 1A2 01 TO S1 M=3.0 NOZ,PC/PT=1.2 NOM	.000	.000	.000	2.000	YMRP .0000 FT.
(RBJ035)	AMES 97-616 1A2 01 TO S1 M=3.0 NOZ,PC/PT=0.8 NOM	.000	.000	.000	2.000	ZMRP 4.0000 FT.
						SCALE .0190

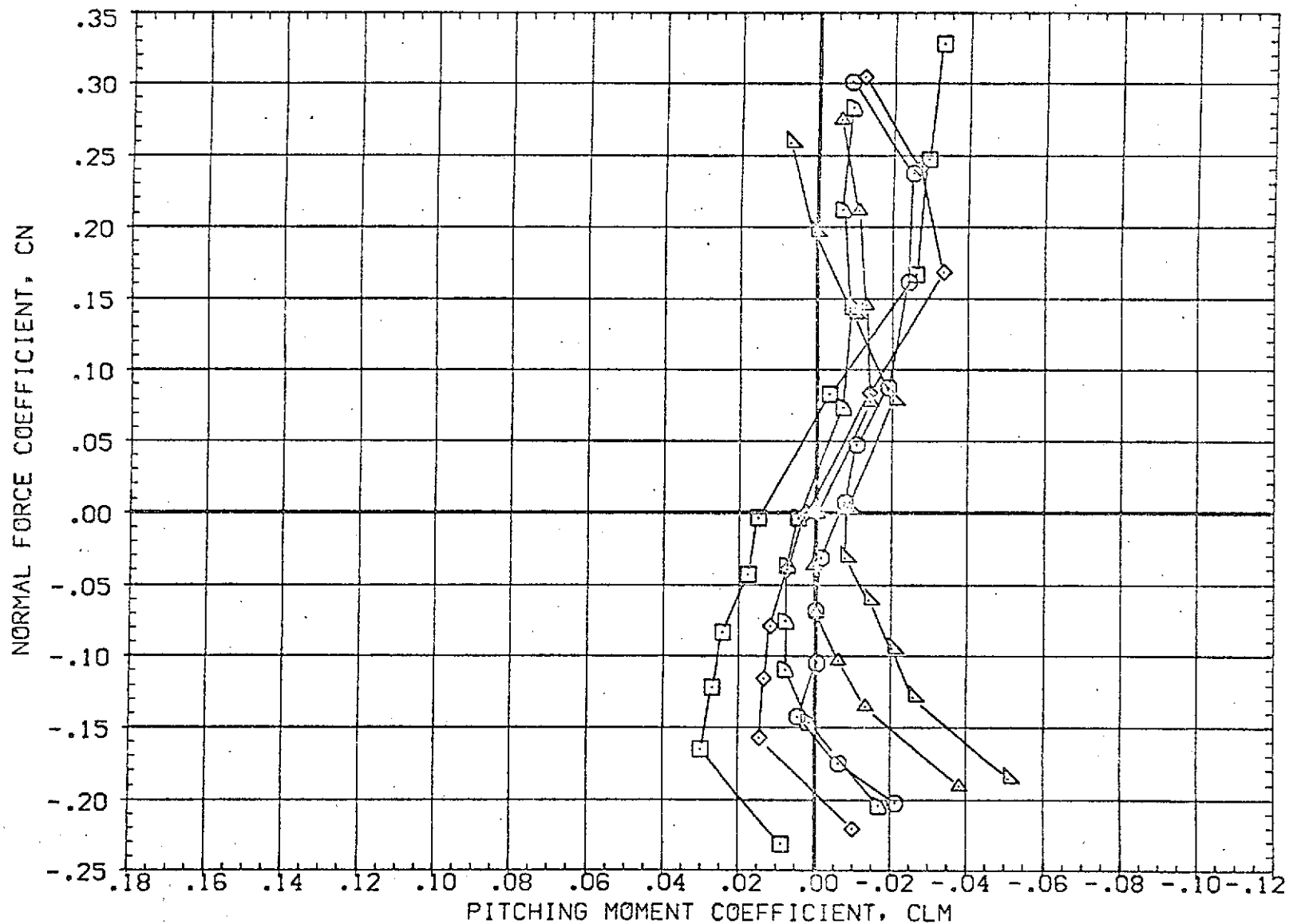

FIG 9 EFFECT OF NOZZLE DESIGN POINT ON LONGITUDINAL CHARACTERISTICS

(A) MACH = 1.60

DATA SET SYMBOL	CONFIGURATION DESCRIPTION	ELEVON	AILRON	RUDDER	PLUMES	REFERENCE INFORMATION
(EBJ001)	AMES 97-616 1A2 01 TO S1 PC/PT NOM, SRM A/A=8	.000	.000	.000	5.000	SREF 3155.0000 SQ.FT.
(RBJ031)	AMES 97-616 1A2 01 TO S1 M=.9 NOZ, PC/PT=.92 NOM	.000	.000	.000	2.000	LREF 50.8000 FT.
(RBJ032)	AMES 97-616 1A2 01 TO S1 M=.9 NOZ, PC/PT=1.1 NOM	.000	.000	.000	2.000	BREF 73.5000 FT.
(RBJ033)	AMES 97-616 1A2 01 TO S1 M=3.0 NOZ, PC/PT=NOM	.000	.000	.000	2.000	XMRP 88.4167 FT.
(RBJ034)	AMES 97-616 1A2 01 TO S1 M=3.0 NOZ, PC/PT=1.2 NOM	.000	.000	.000	2.000	YMRP .0000 FT.
(RBJ035)	AMES 97-616 1A2 01 TO S1 M=3.0 NOZ, PC/PT=0.8 NOM	.000	.000	.000	2.000	ZMRP 4.0000 FT.
						SCALE .0190

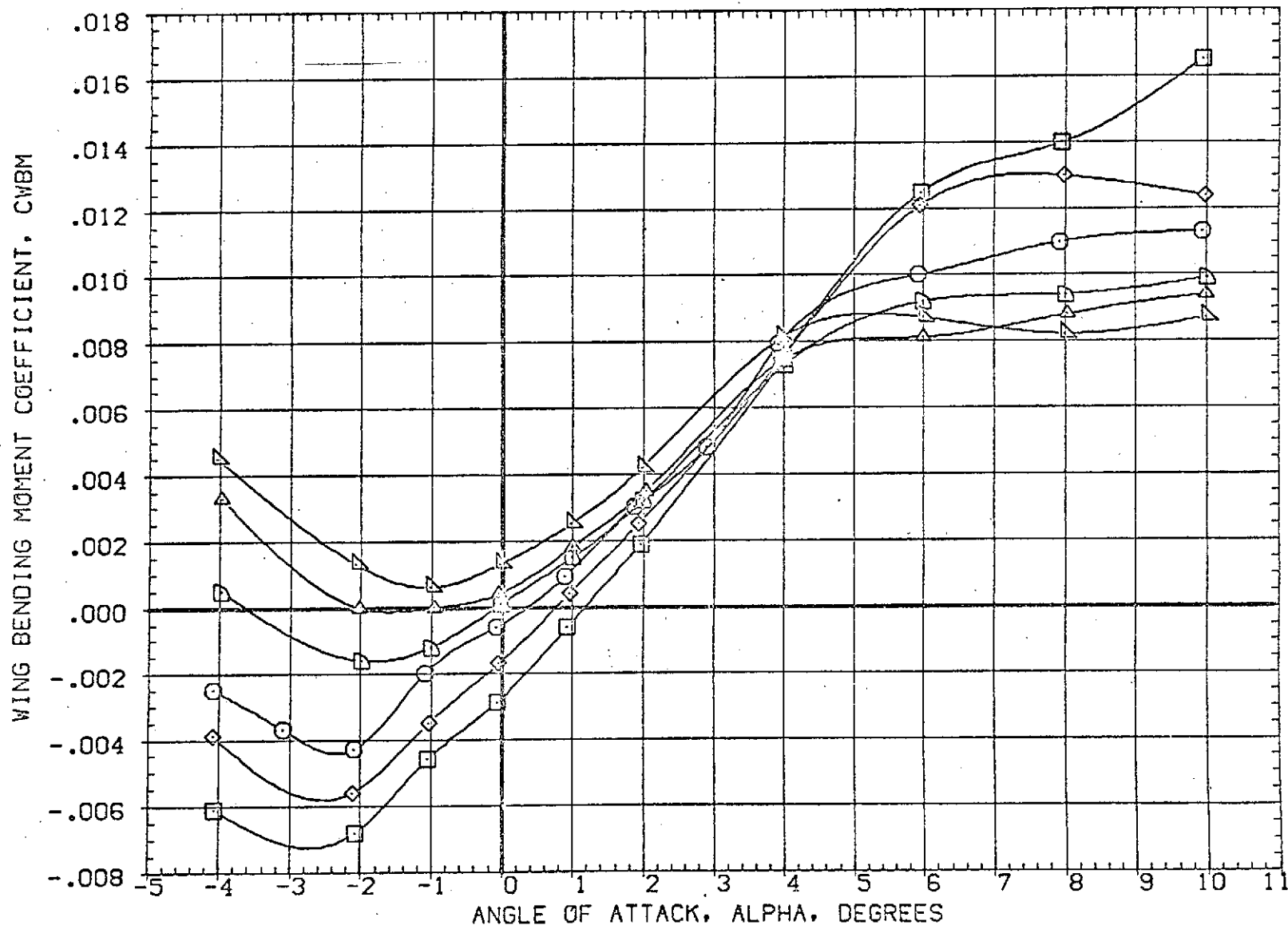

FIG 9 EFFECT OF NOZZLE DESIGN POINT ON LONGITUDINAL CHARACTERISTICS

(A)MACH = 1.60

DATA SET SYMBOL	SYMBOL	CONFIGURATION DESCRIPTION	ELEVON	AILERON	RUDDER	PLUMES	REFERENCE INFORMATION		
(DBJ501)	○	AMES 97-616 1A2 01 TO S1 NO PLUMES	.000	.000	.000	.000	SREF	3155.0000	50. FT.
(DBJ001)	□	AMES 97-616 1A2 01 TO S1 PC/PT NOM. SRM A/A=8	.000	.000	.000	5.000	LREF	50.8000	50. FT.
(RBJ003)	◇	AMES 97-616 1A2 01 TO S1 PC/PT NOM. SRM A/A=8	.000	.000	.000	2.000	BREF	73.5000	73.5 FT.
(DBJ005)	△	AMES 97-616 1A2 01 TO S1 PC/PT NOM	.000	.000	.000	3.000	XMRP	86.4167	86.4 FT.
							YMRP	.0000	. FT.
							ZMRP	4.0000	4. FT.
							SCALE	.0190	

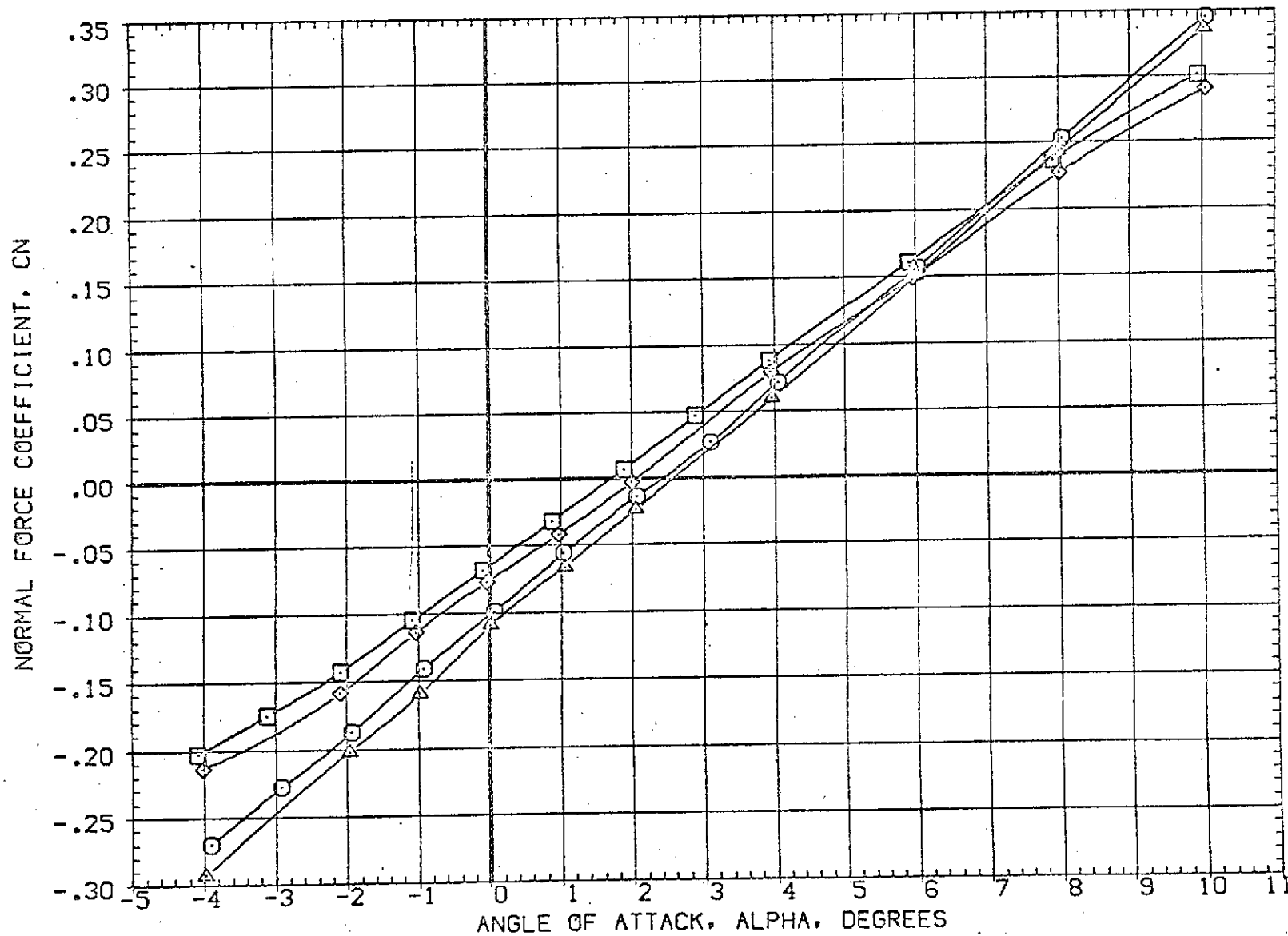

FIG 10 EFFECT OF ORBITER AND SRM PLUMES ON LONGITUDINAL CHARACTERISTICS, BETA=0

(A) MACH = 1.60

DATA SET SYMBOL	CONFIGURATION DESCRIPTION	ELEVON	AILRON	RUDDER	PLUMES	REFERENCE INFORMATION	
(OBJ501)	AMES 97-616 1A2 01 TO S1 NO PLUMES	.000	.000	.000	.000	SREF	3155.0000 SQ.FT.
(OBJ001)	AMES 97-616 1A2 01 TO S1 PC/PT NCM SRM A/A=8	.000	.000	.000	5.000	LREF	50.8000 FT.
(OBJ003)	AMES 97-616 1A2 01 TO S1 PC/PT NCM SRM A/A=8	.000	.000	.000	2.000	BREF	73.5000 FT.
(OBJ005)	AMES 97-616 1A2 01 TO S1 PC/PT NCM	.000	.000	.000	3.000	XMRRP	86.4167 FT.
						YMRRP	.0000 FT.
						ZMRRP	4.0000 FT.
						SCALE	.0150

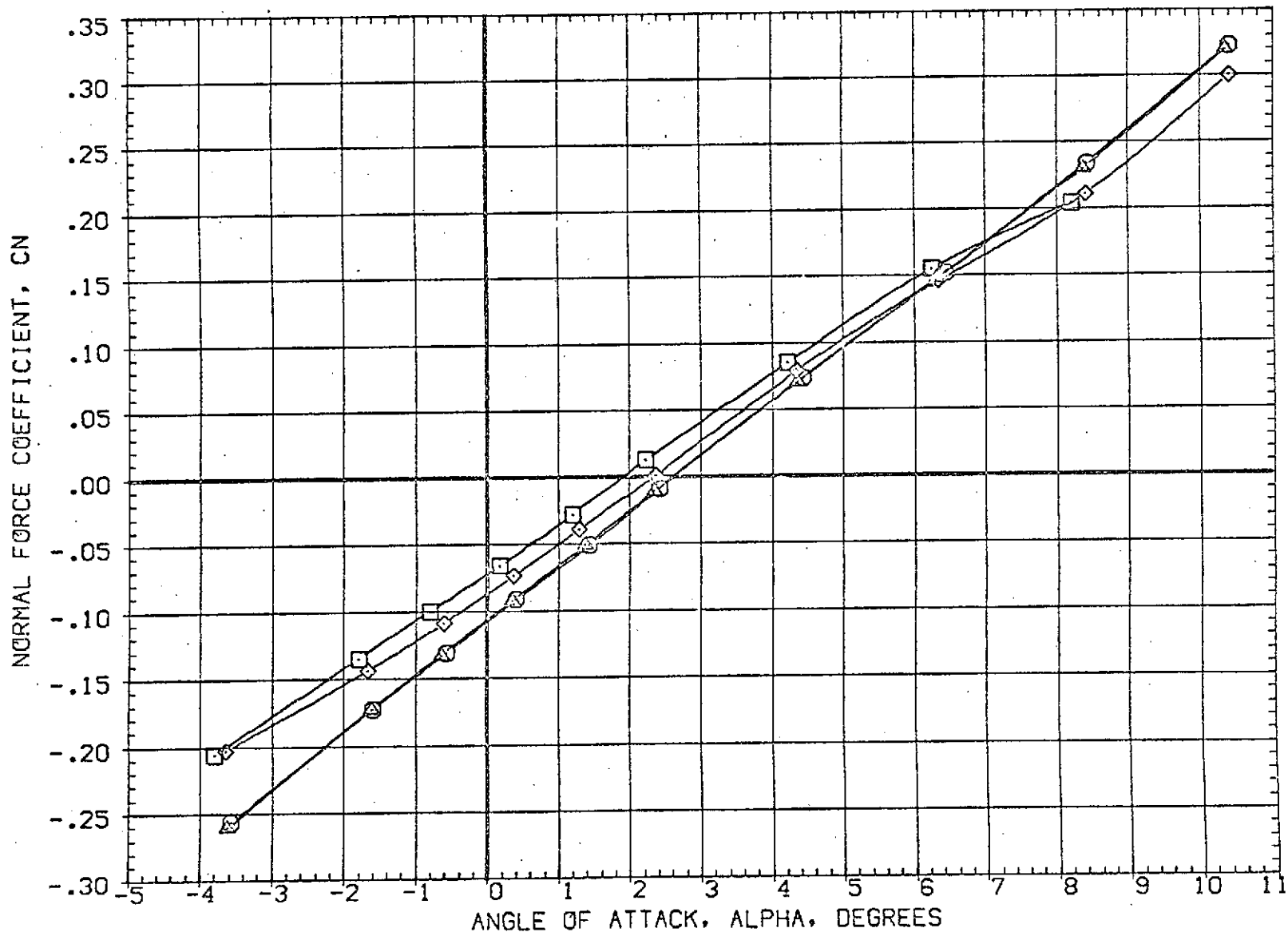

FIG 10 EFFECT OF ORBITER AND SRM PLUMES ON LONGITUDINAL CHARACTERISTICS, BETA=0
 (B)MACH = 1.98

DATA SET SYMBOL	CONFIGURATION DESCRIPTION	ELEVON	AILERON	RUDDER	LUMES	REFERENCE IN CLINICAL	SCALE
(OBJ501)	AMES 97-616 1A2 01 TO S1 NO PLUMES	.000	.000	.000	.000	SREF 3155.0000	SG.FT.
(OBJ001)	AMES 97-616 1A2 01 TO S1 PC/PT NOM. SRM A/A-8	.000	.000	.000	5.000	LREF 59.8000	FT.
(RB3C03)	AMES 97-616 1A2 01 TO S1 PC/PT NOM. SRM A/A-8	.000	.000	.000	2.000	BREF 73.5000	FT.
(OBJ005)	AMES 97-616 1A2 01 TO S1 PC/PT NOM	.000	.000	.000	3.000	XMRP 86.4167	FT.
						YMRP .0000	FT.
						ZMRP 4.0000	FT.
						SCALE .0150	

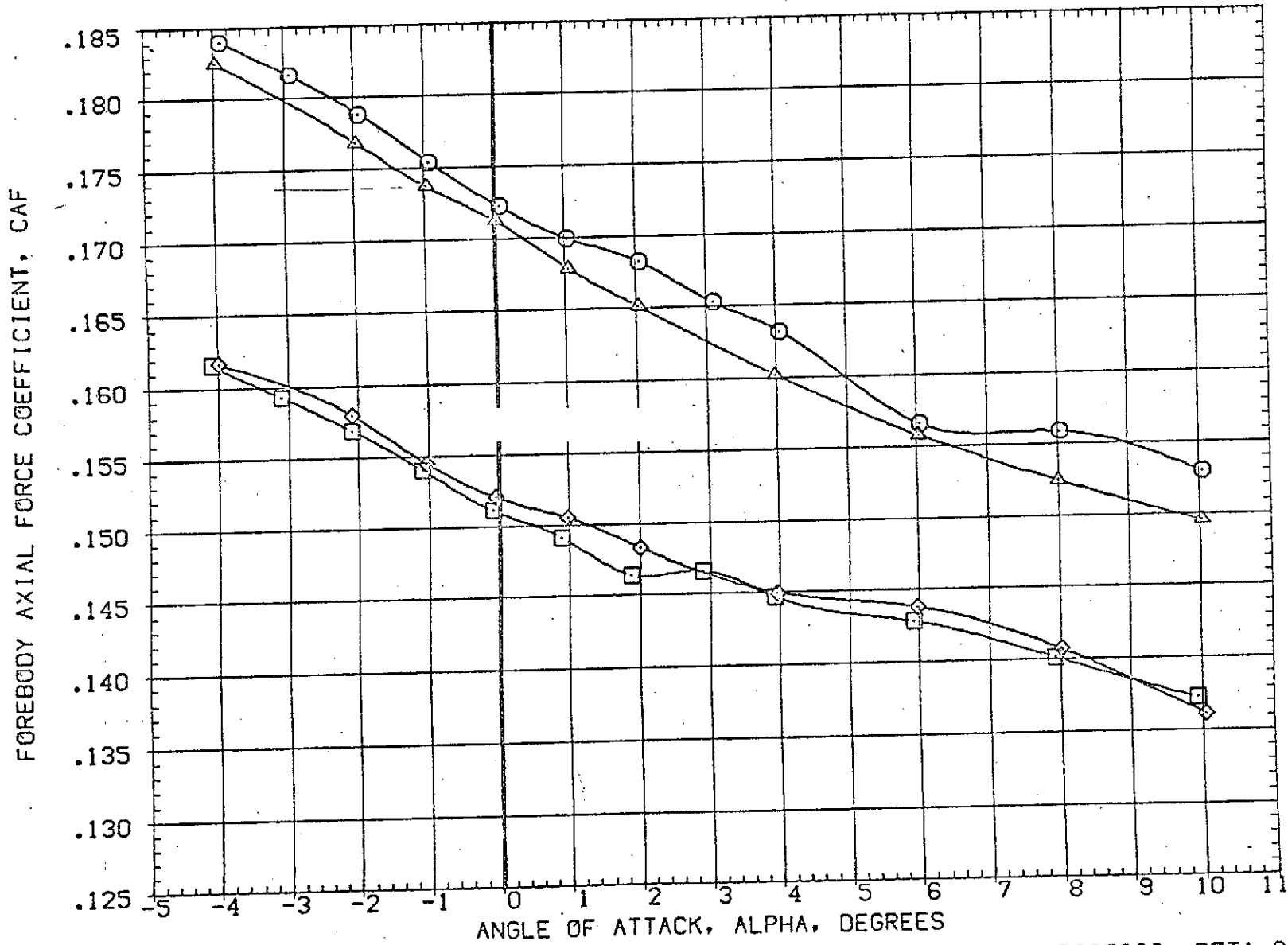

FIG 10 EFFECT OF ORBITER AND SRM PLUMES ON LONGITUDINAL CHARACTERISTICS, BETA=0
 (A)MACH = 1.60

DATA SET SYMBOL	CONFIGURATION DESCRIPTION	ELEVON	AILRON	RUDDER	PLUMES	REFERENCE INFORMATION
(DBJ501)	AMES 97-616 1A2 01 TO S1 NO PLUMES	.000	.000	.000	.000	SREF 3155.0000 SQ.FT.
(DBJ001)	AMES 97-616 1A2 01 TO S1 PC/PT NOM.SRM A/A=8	.000	.000	.000	5.000	LREF 50.8000 FT.
(RBJ003)	AMES 97-616 1A2 01 TO S1 PC/PT NOM.SRM A/A=8	.000	.000	.000	2.000	BREF 73.5000 FT.
(DBJ005)	AMES 97-616 1A2 01 TO S1 PC/PT NOM	.000	.000	.000	3.000	XMRP 86.4167 FT.
						YMRP .0000 FT.
						ZMRP 4.0000 FT.
						SCALE .0190

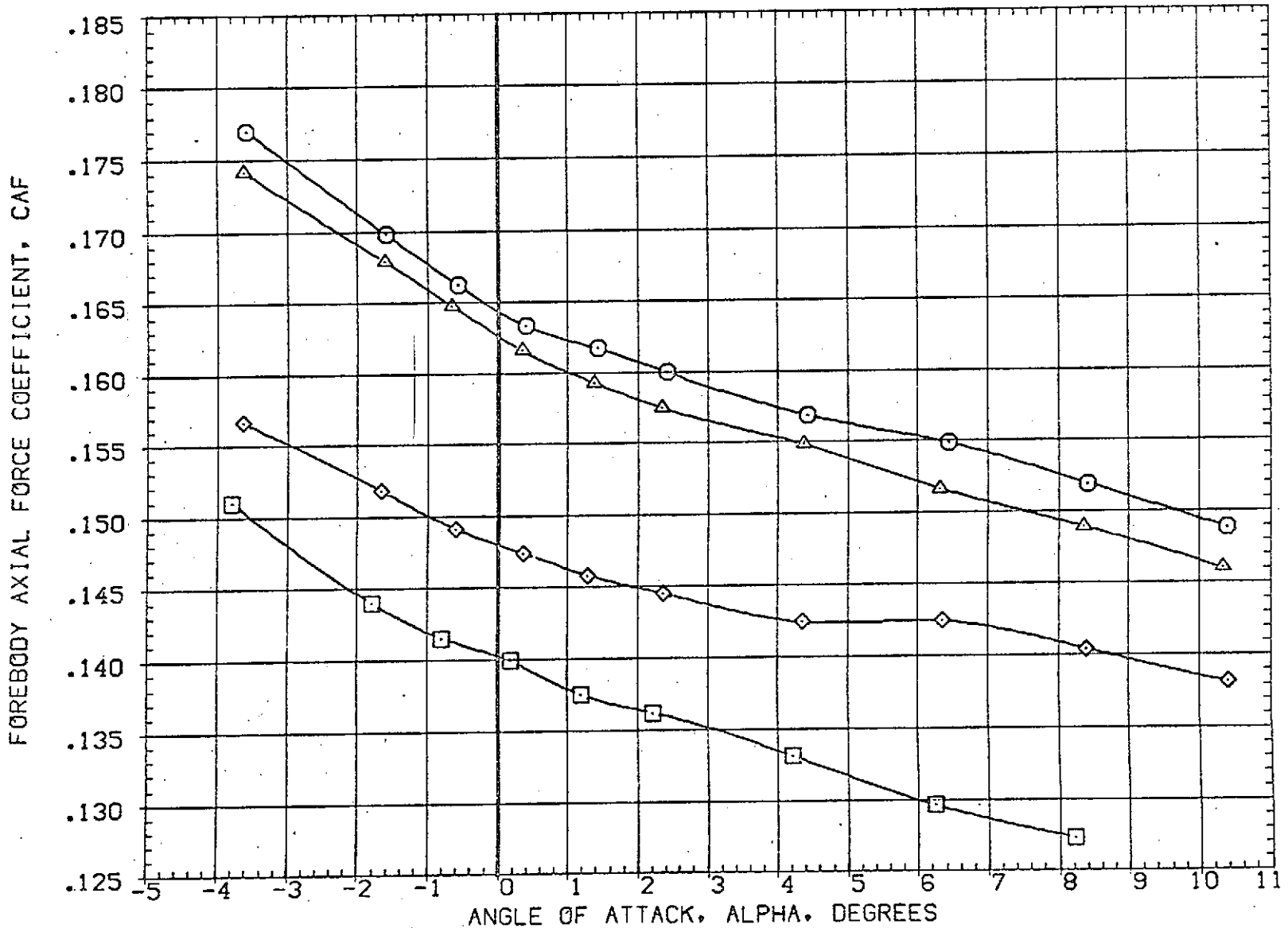

FIG 10 EFFECT OF ORBITER AND SRM PLUMES ON LONGITUDINAL CHARACTERISTICS, BETA=0

(B)MACH = 1.98

DATA SET SYMBOL	CONFIGURATION DESCRIPTION
(DBJ501)	AMES 97-616 1A2 01 TO SI NO PLUMES
(DBJ001)	AMES 97-616 1A2 01 TO SI PC/PT NOM. SRM A/A=8
(RBJ003)	AMES 97-616 1A2 01 TO SI PC/PT NOM. SRM A/A=8
(DBJ005)	AMES 97-616 1A2 01 TO SI PC/PT NOM

ELEVON	AILERON	RUDDER	PLUMES	REFERENCE TO ORIGIN
.000	.000	.000	.000	SREF 3155.0000 50. FT.
.000	.000	.000	5.000	LREF 50.8000 FT.
.000	.000	.000	2.000	BREF 73.5000 FT.
.000	.000	.000	3.000	XMRP 86.4167 FT.
				YMRP .0000 FT.
				ZMRP 4.0000 FT.
				SCALE .0190

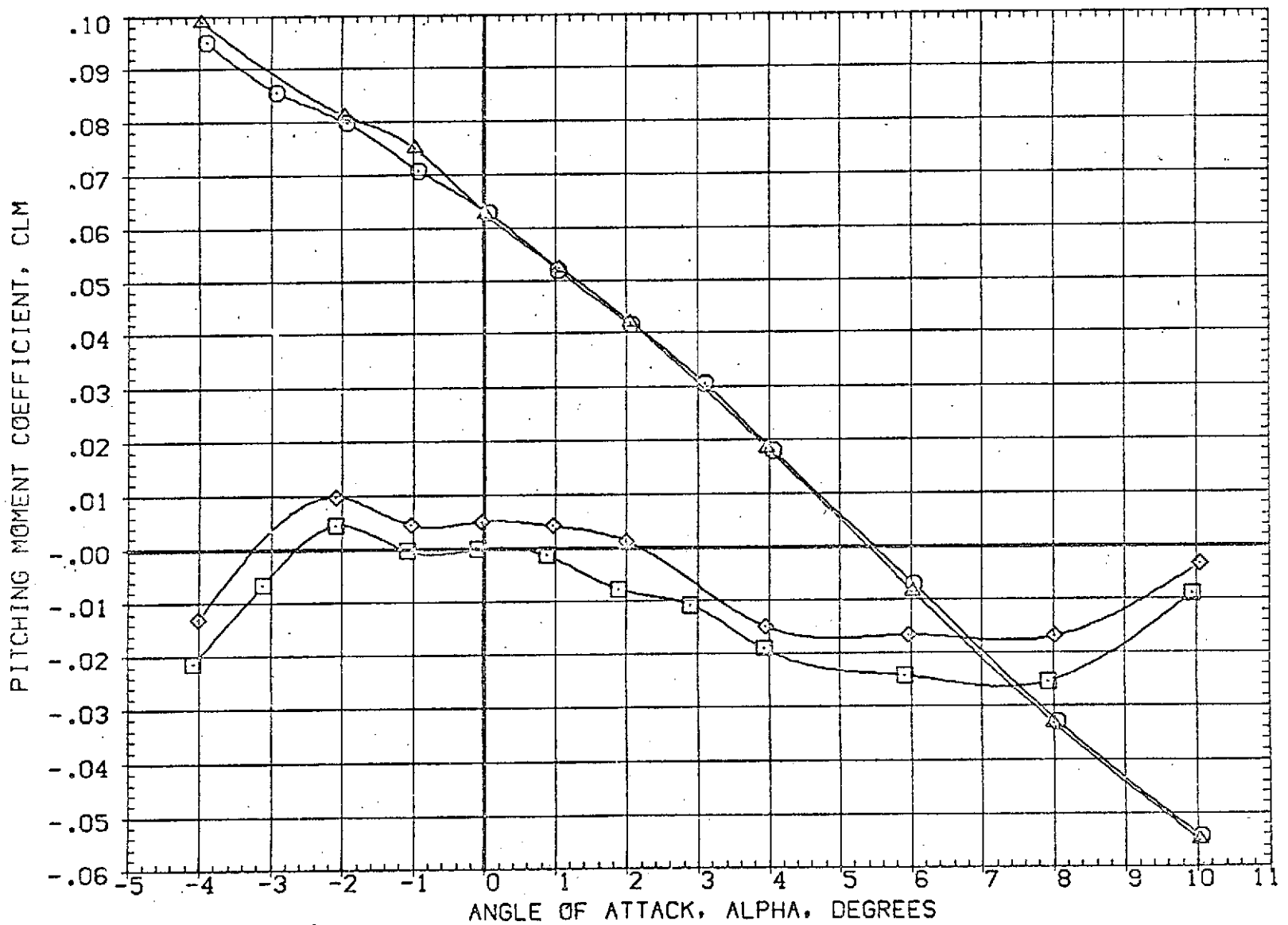

FIG 10 EFFECT OF ORBITER AND SRM PLUMES ON LONGITUDINAL CHARACTERISTICS, BETA=0
 (A) MACH = 1.60 PAGE 32

DATA SET SYMBOL	CONFIGURATION DESCRIPTION	ELEVON	AILRON	RUDDER	PLUMES	REFERENCE INFORMATION
(DBJ501)	AMES 97-616 IA2 01 TO S1 NO PLUMES	.000	.000	.000	.000	SREF 3155.0000 SQ.FT.
(DBJ001)	AMES 97-616 IA2 01 TO S1 PC/PT NOM. SRM A/A=8	.000	.000	.000	5.000	LREF 50.8000 FT.
(RBJ003)	AMES 97-616 IA2 01 TO S1 PC/PT NOM. SRM A/A=8	.000	.000	.000	2.000	BREF 73.5000 FT.
(DBJ005)	AMES 97-616 IA2 01 TO S1 PC/PT NOM	.000	.000	.000	3.000	XMRP 86.4167 FT. YMRP .0000 FT. ZMRP 4.0000 FT. SCALE .0190

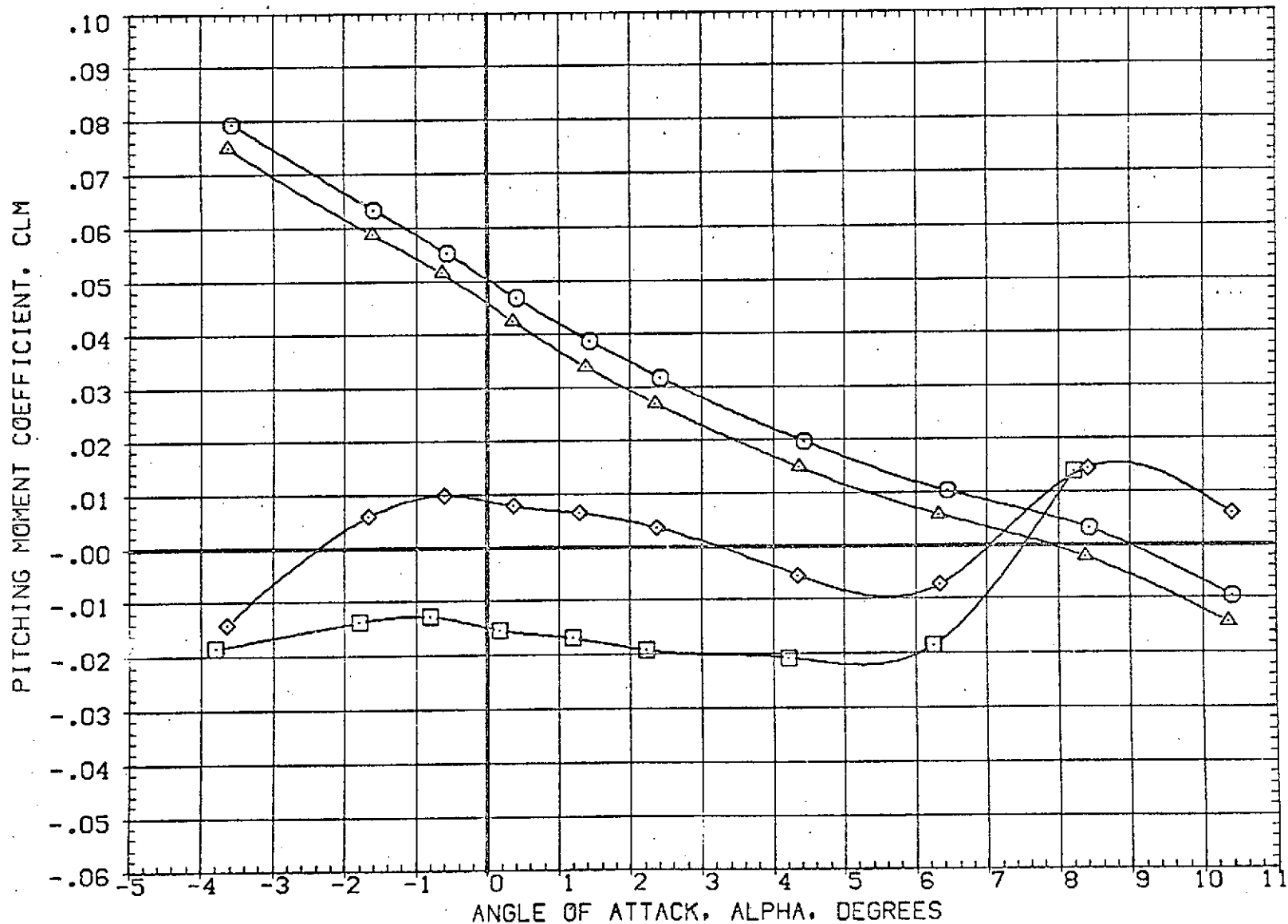

FIG 10 EFFECT OF ORBITER AND SRM PLUMES ON LONGITUDINAL CHARACTERISTICS, BETA=0

(B)MACH = 1.98

DATA SET SYMBOL	CONFIGURATION DESCRIPTION	ELEVON	AILRON	RUDDER	PLUMES	REFERENCE INFORMATION		
(DBJ501)	AMES 97-616 1A2 01 TO S1 NO PLUMES	.000	.000	.000	.000	SREF	3155.0000	50.FT.
(DBJ001)	AMES 97-616 1A2 01 TO S1 PC/PT NCM,SRM A/A=8	.000	.000	.000	5.000	LREF	50.8000	FT.
(RBJ003)	AMES 97-616 1A2 01 TO S1 PC/PT NCM,SRM A/A=8	.000	.000	.000	2.000	BREF	73.5000	FT.
(DBJ005)	AMES 97-616 1A2 01 TO S1 PC/PT NCM	.000	.000	.000	3.000	XMRP	86.4167	FT.
						YMRP	.0000	FT.
						ZMRP	4.0000	FT.
						SCALE	.0190	

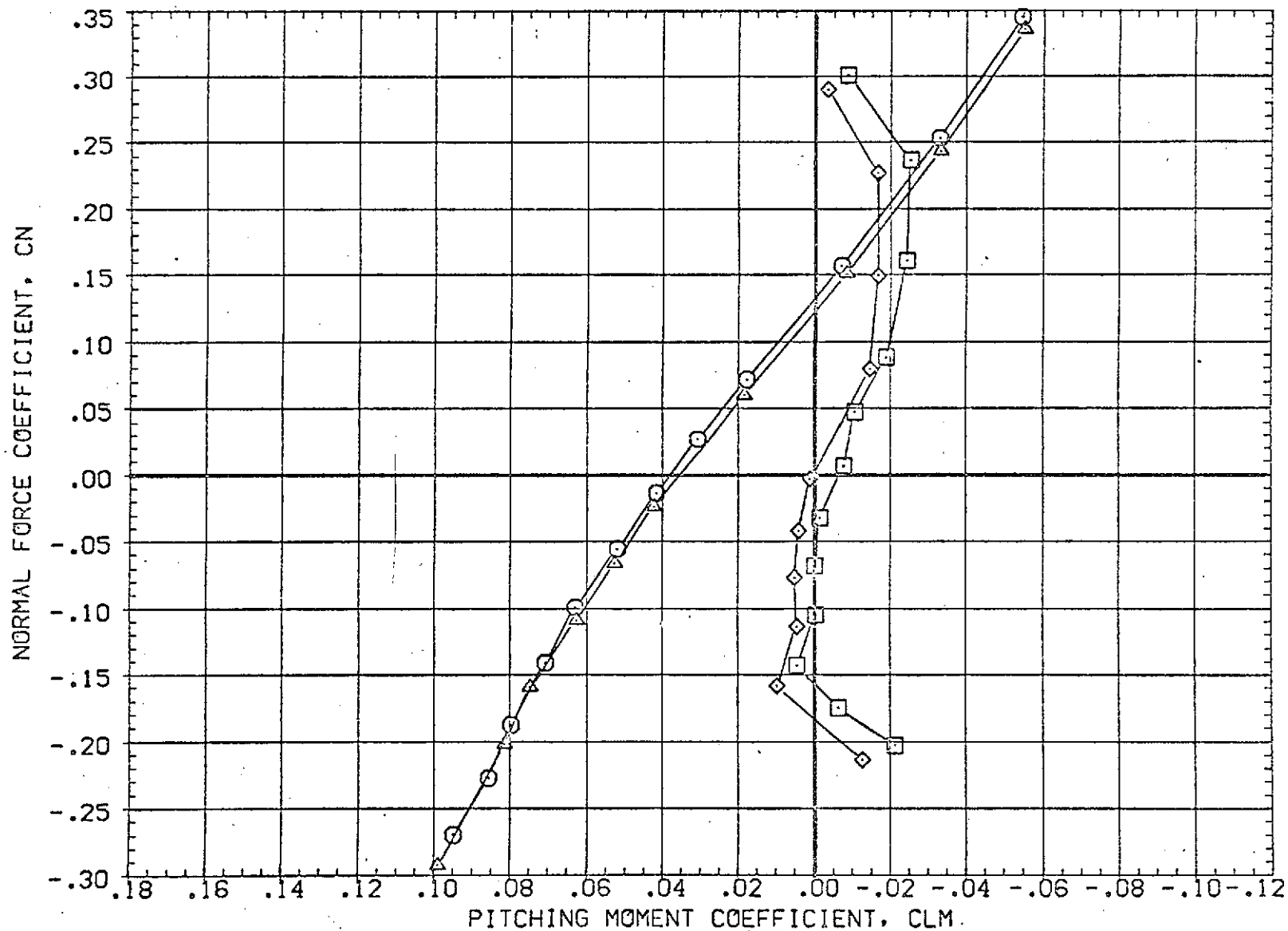

FIG 10 EFFECT OF ORBITER AND SRM PLUMES ON LONGITUDINAL CHARACTERISTICS, BETA=0

(A)MACH = 1.60

DATA SET SYMBOL	CONFIGURATION DESCRIPTION	ELEVON	AILRON	RUDDER	PLUMES	REFERENCE INFORMATION
(DBJ501)	AMES 97-616 IA2 01 TO S1 NO PLUMES	.000	.000	.000	.000	SREF 3155.0000 SQ.FT.
(DBJ001)	AMES 97-616 IA2 01 TO S1 PC/PT NOM, SRM A/A=8	.000	.000	.000	5.000	LREF 50.8000 FT.
(RBJC03)	AMES 97-616 IA2 01 TO S1 PC/PT NOM, SRM A/A=8	.000	.000	.000	2.000	BREF 73.5000 FT.
(DBJ005)	AMES 97-616 IA2 01 TO S1 PC/PT NOM	.000	.000	.000	3.000	XMRP 86.4167 FT.
						YMRP .0000 FT.
						ZMRP 4.0000 FT.
						SCALE .0193

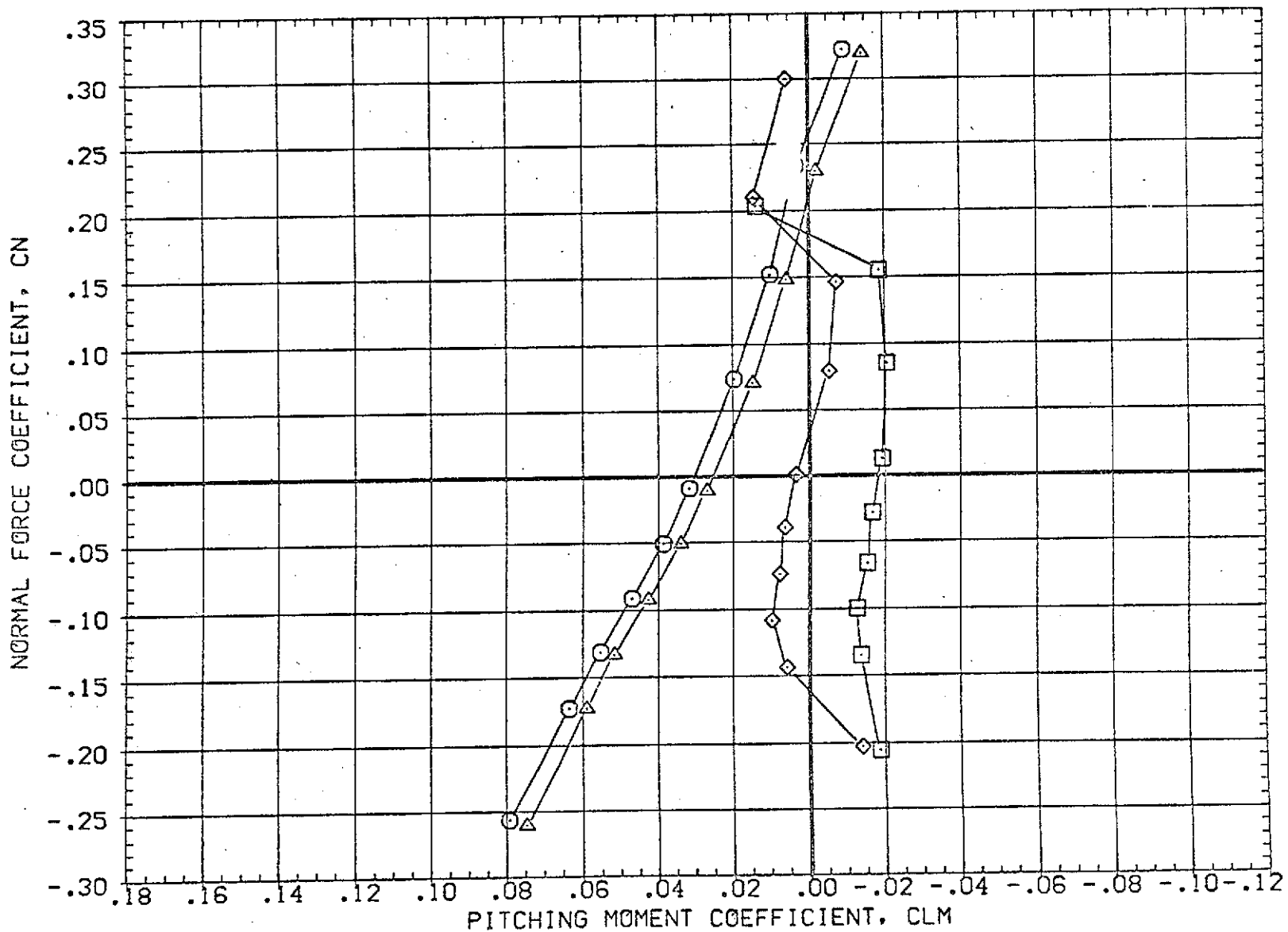

FIG 10 EFFECT OF ORBITER AND SRM PLUMES ON LONGITUDINAL CHARACTERISTICS, BETA=0

DATA SET SYMBOL	CONFIGURATION DESCRIPTION	ELEVON	AIRLON	RUDDER	PLUMES	RE. E. UNCL. IN. ORIGIN	SO. FT.
(DBJ501)	AMES 97-616 1A2 01 TO S1 NO PLUMES	.000	.000	.000	5.000	SREF	3155.0000
(DBJ001)	AMES 97-616 1A2 01 TO S1 PC/PT NOM. SRM A/A=8	.000	.000	.000	5.000	LREF	50.8000
(RBJ003)	AMES 97-616 1A2 01 TO S1 PC/PT NOM. SRM A/A=8	.000	.000	.000	2.000	BREF	73.5000
(DBJ005)	AMES 97-616 1A2 01 TO S1 PC/PT NOM	.000	.000	.000	3.000	XMRP	88.4167
						YMRP	.0000
						ZMRP	4.0000
						SCALE	.0190

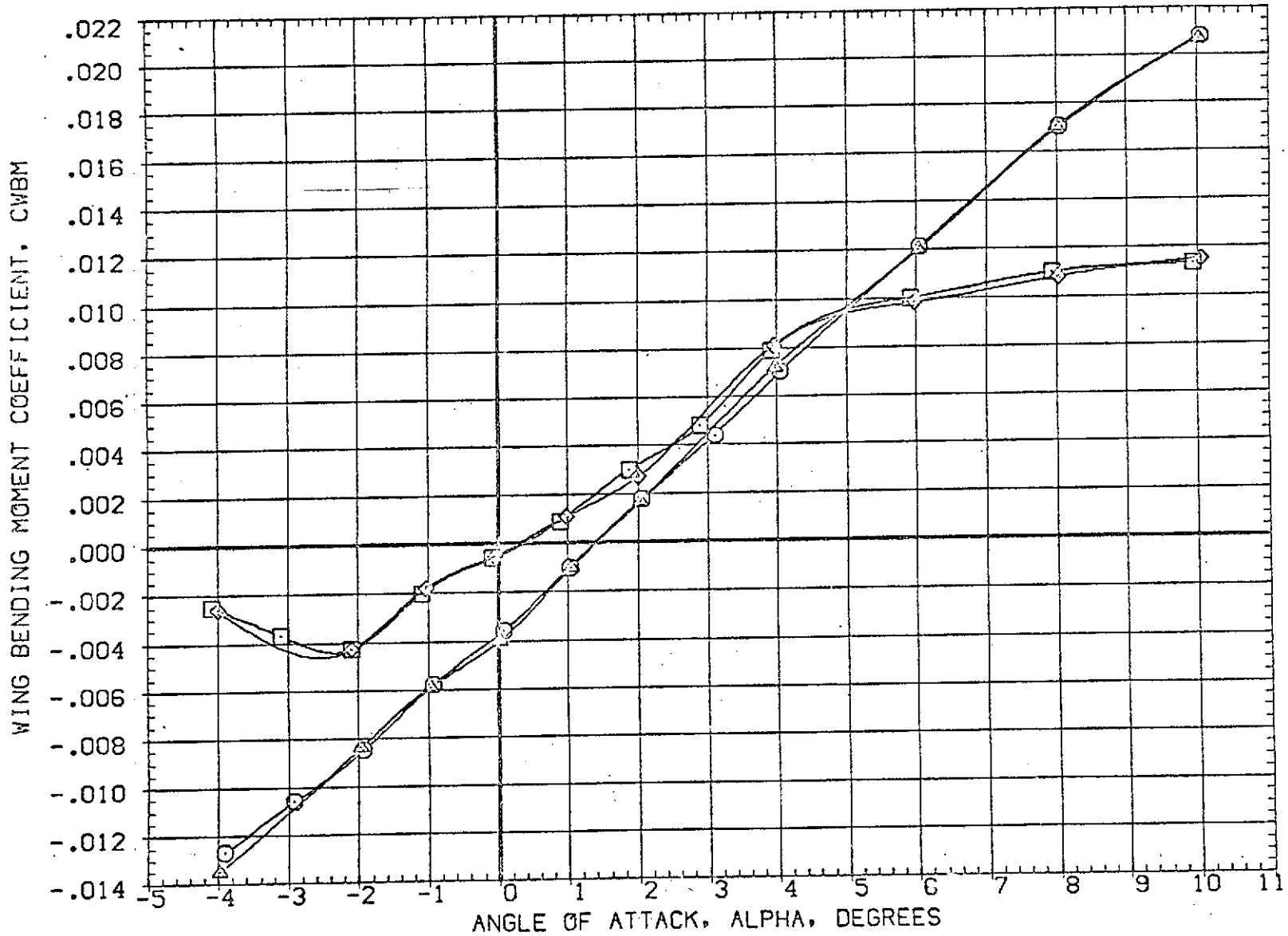

FIG 10 EFFECT OF ORBITER AND SRM PLUMES ON LONGITUDINAL CHARACTERISTICS, BETA=0
 (A)MACH = 1.60

DATA SET SYMBOL	CONFIGURATION DESCRIPTION	ELEVON	AILRON	RUDDER	PLUMES	REFERENCE INFORMATION	
(DBJ501)	AMES 97-616 IA2 01 TO S1 NO PLUMES	.000	.000	.000	.000	SREF	3155.0000 SQ.FT.
(DBJ001)	AMES 97-616 IA2 01 TO S1 PC/PT NOM, SRM A/A=8	.000	.000	.000	5.000	LREF	50.8000 FT.
(RBJ003)	AMES 97-616 IA2 01 TO S1 PC/PT NOM, SRM A/A=8	.000	.000	.000	2.000	BREF	73.5000 FT.
(DBJ005)	AMES 97-616 IA2 01 TO S1 PC/PT NOM	.000	.000	.000	3.000	XMRP	86.4167 FT.
						YMRP	.0000 FT.
						ZMRP	4.0000 FT.
						SCALE	.0190

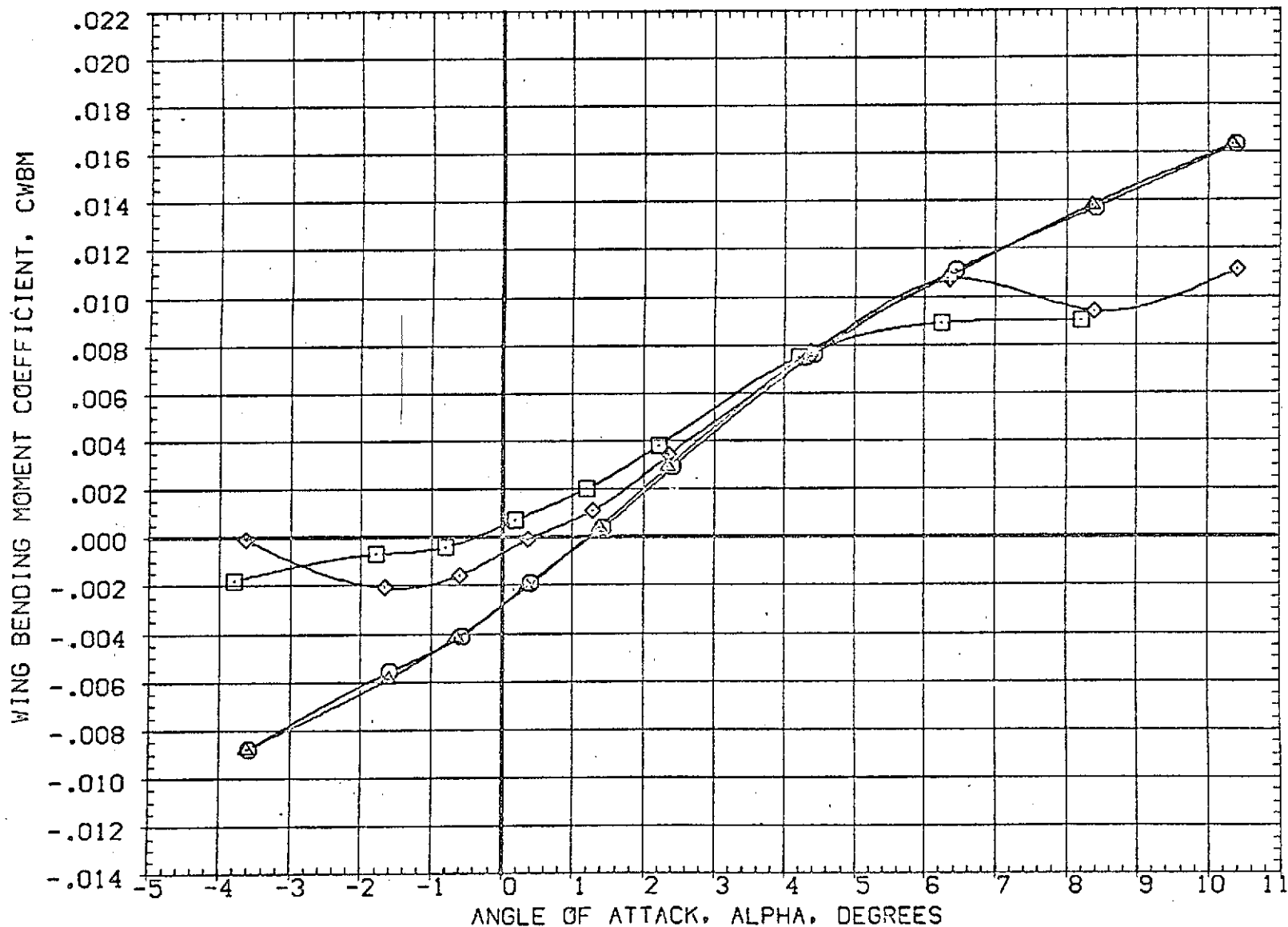

FIG 10 EFFECT OF ORBITER AND SRM PLUMES ON LONGITUDINAL CHARACTERISTICS, BETA=0
 (B)MACH = 1.98

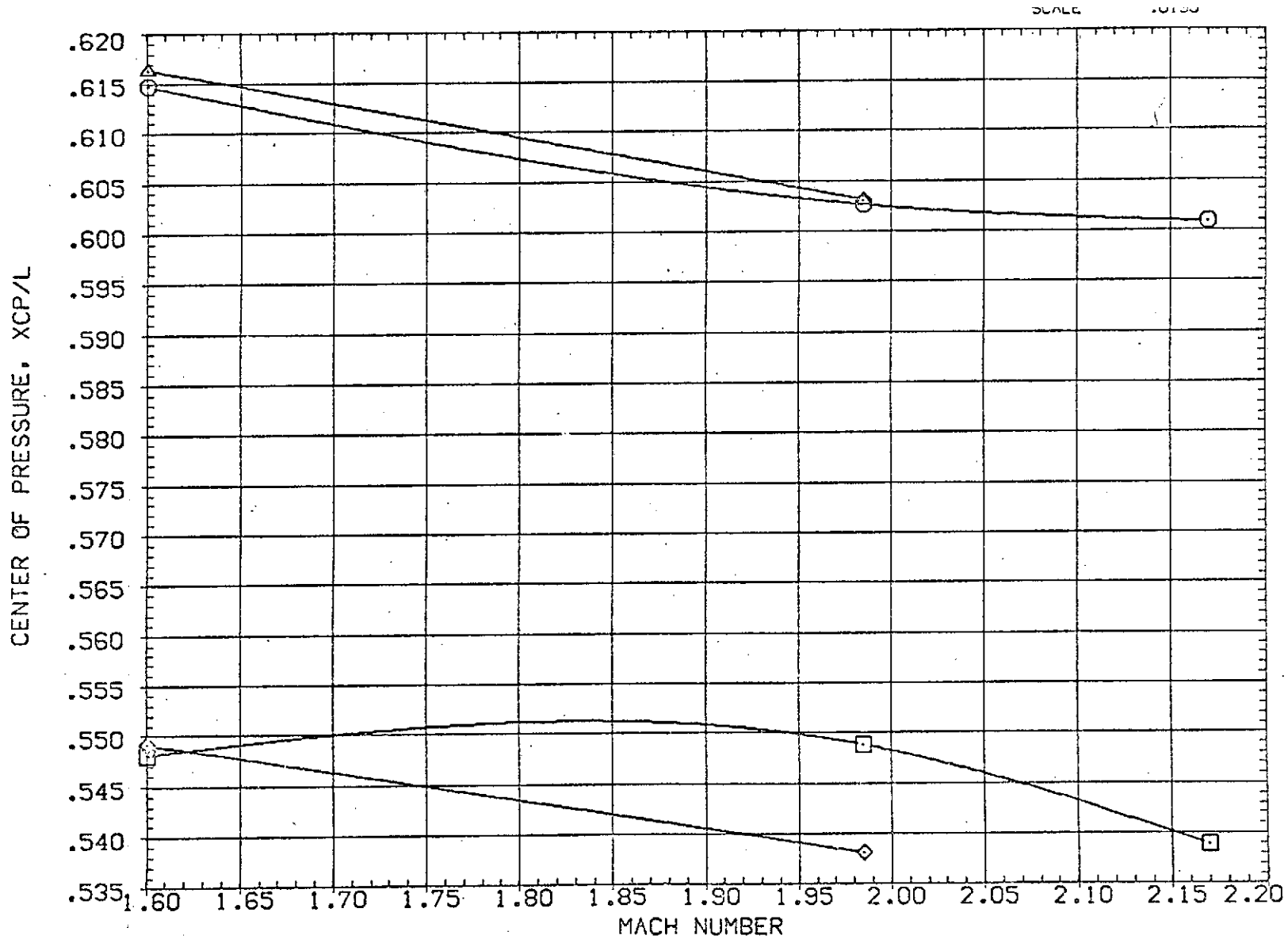

FIG 10 EFFECT OF ORBITER AND SRM PLUMES ON LONGITUDINAL CHARACTERISTICS, BETA=0

DATA SET SYMBOL	CONFIGURATION DESCRIPTION	ELEVON	AILRON	RUDDER	PLUMES	REFERENCE INFORMATION	
(CBJS01)	AMES 97-616 1A2 01 T0 S1 NO PLUMES	.000	.000	.000	.000	SREF	3155.0000 SQ.FT.
(CBJ001)	AMES 97-616 1A2 01 T0 S1 PC/PT NOM, SRM A/A=8	.000	.000	.000	5.000	LREF	50.8000 FT.
(CBJ003)	AMES 97-616 1A2 01 T0 S1 PC/PT NOM, SRM A/A=8	.000	.000	.000	2.000	BREF	73.5000 FT.
(CBJ005)	AMES 97-616 1A2 01 T0 S1 PC/PT NOM	.000	.000	.000	3.000	XMRP	86.4167 FT.
						YMRP	.0000 FT.
						ZMRP	4.0000 FT.
						SCALE	.0190

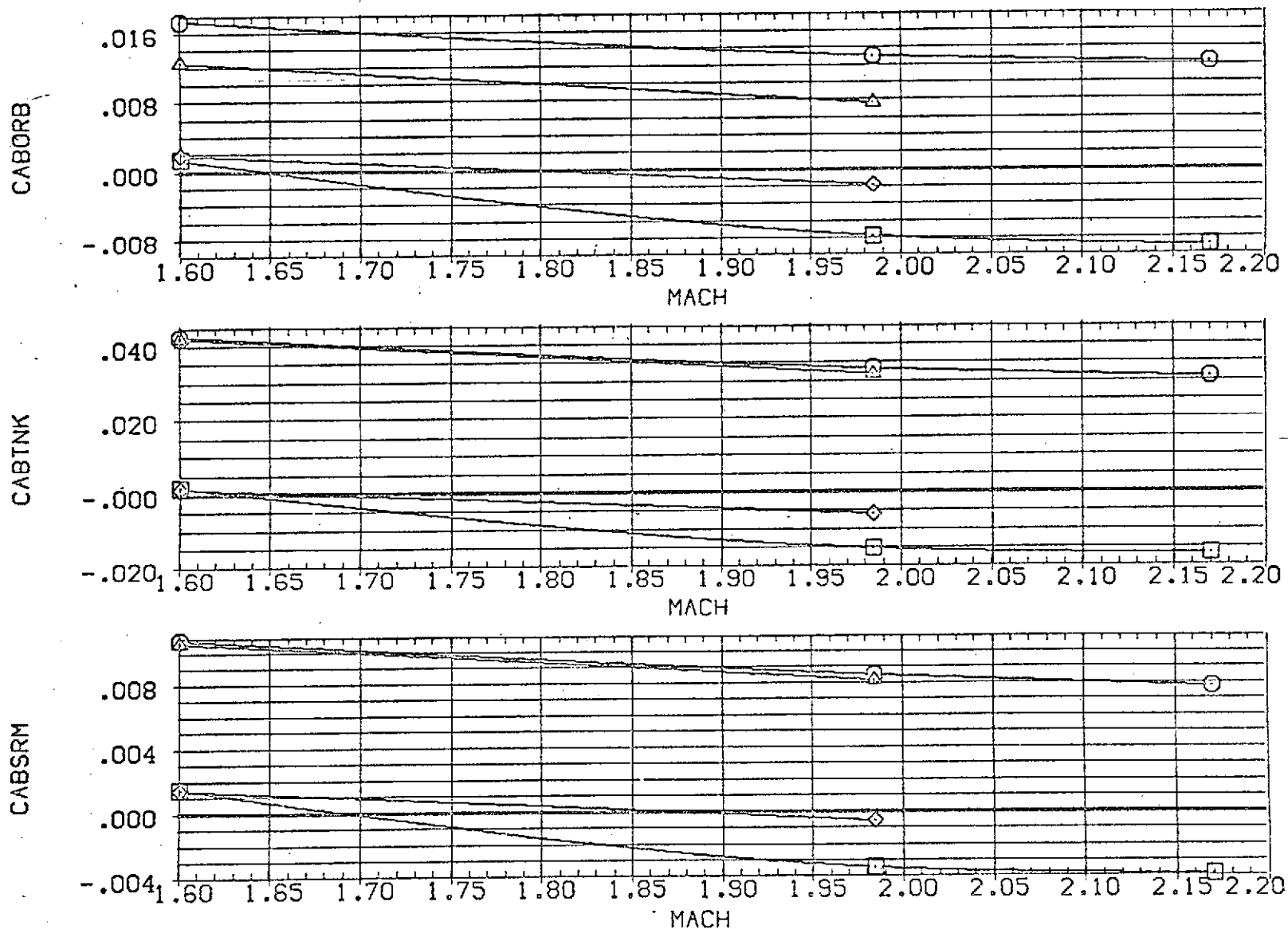

FIG 10 EFFECT OF ORBITER AND SRM PLUMES ON LONGITUDINAL CHARACTERISTICS, BETA=0

DATA SET	SYMBOL	CONFIGURATION DESCRIPTION	ELEVON	AILRON	RUDDER	PLUMES	REFERENCE INFORMATION
(DBJ502)	○	AMES 97-616 1A2 01 TO S1 NO PLUMES	.000	.000	.000	.000	SREF 3155.0000 SQ.FT.
(HBJ002)	□	AMES 97-616 1A2 01 TO S1 PC/PT NOM. SRM A/A=8	.000	.000	.000	5.000	LREF 50.8000 FT.
(RBJ004)	×	AMES 97-616 1A2 01 TO S1 PC/PT NOM. SRM A/A=8	.000	.000	.000	2.000	BREF 73.5000 FT.
(DBJ006)	△	AMES 97-616 1A2 01 TO S1 PC/PT NOM	.000	.000	.000	3.000	XMRP 86.4167 FT.
							YMRP .0000 FT.
							ZMRP 4.0000 FT.
							SCALE .0190

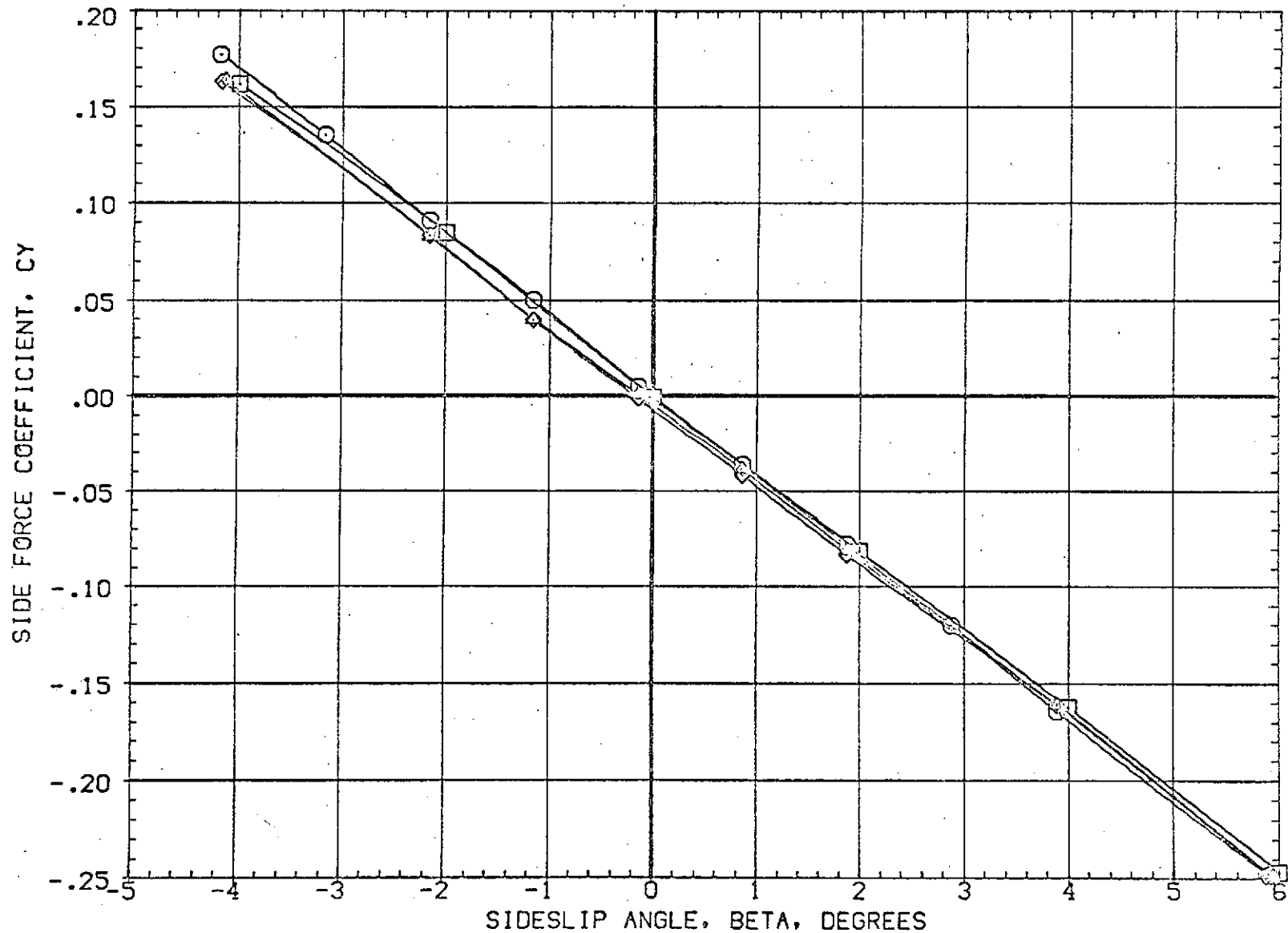

FIG 11 EFFECT OF ORBITER AND SRM PLUMES ON LATERAL CHARACTERISTICS, ALPHA=0.0

(A) MACH = 1.60

DATA SET SYMBOL	CONFIGURATION DESCRIPTION	ELEVON	AILERON	RUDDER	PLUMES	REFERENCE INFORMATION	
(DBJS02)	○ AMES 97-616 1A2 01 TO S1 NO PLUMES	.000	.000	.000	.000	SREF	3155.0000 SQ.FT.
(HBJ002)	□ AMES 97-616 1A2 01 TO S1 PC/PT NOM, SRM A/A=8	.000	.000	.000	5.000	LREF	50.8000 FT.
(RBJ004)	◇ AMES 97-616 1A2 01 TO S1 PC/PT NOM, SRM A/A=8	.000	.000	.000	2.000	BREF	73.5000 FT.
(DBJ006)	△ AMES 97-616 1A2 01 TO S1 PC/PT NOM	.000	.000	.000	3.000	XMRP	86.4167 FT.
						YMRP	.0000 FT.
						ZMRP	4.0000 FT.
						SCALE	.0190

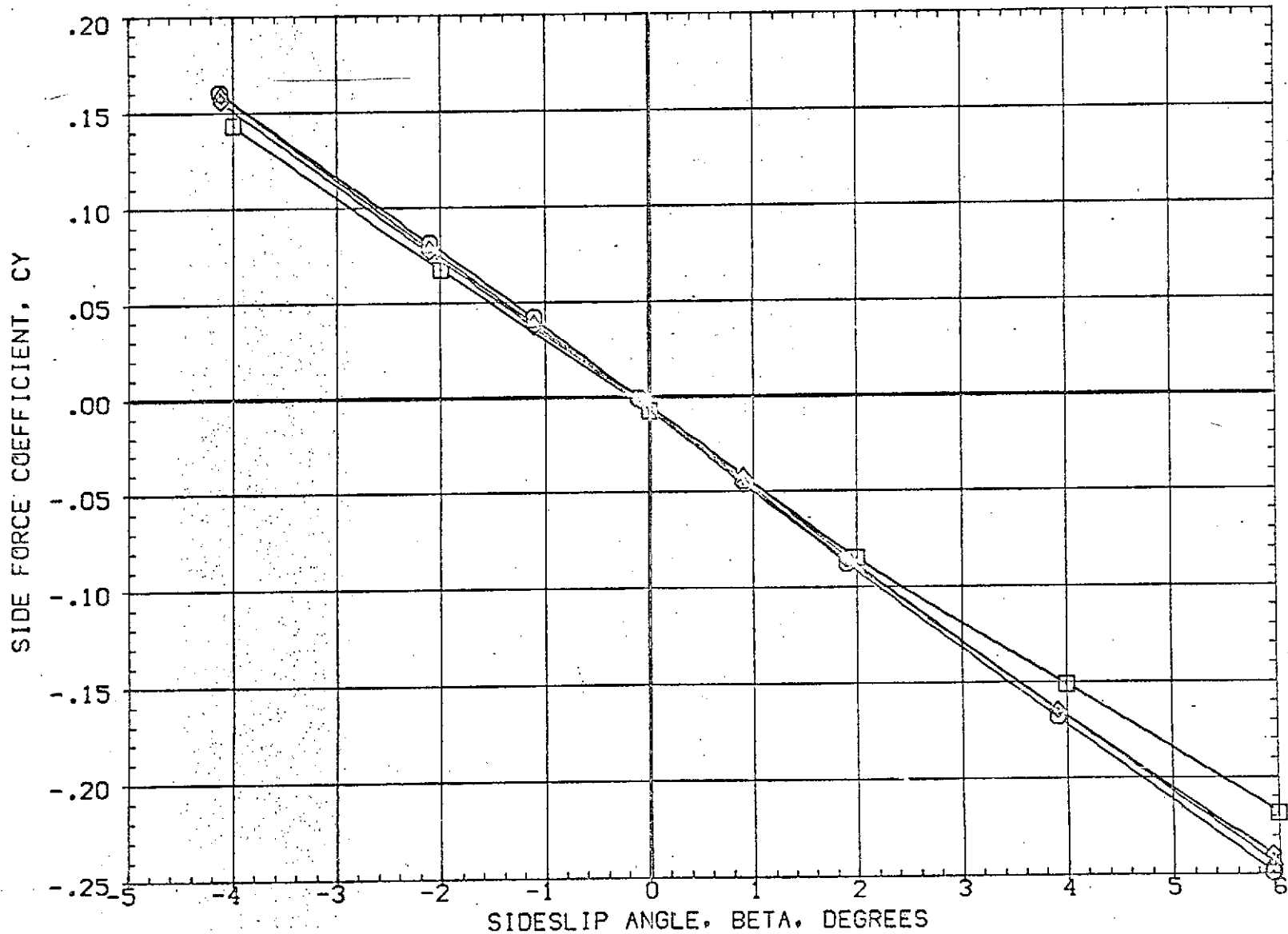

FIG 11 EFFECT OF ORBITER AND SRM PLUMES ON LATERAL CHARACTERISTICS, ALPHA=0.0
 (B)MACH = 1.98

DATA SET SYMBOL	CONFIGURATION DESCRIPTION	ELEVON	AILERON	RUDDER	PLUMES	REFERENCE INFORMATION		
(DBJ502)	AMPS 97-016 1A2 01 TO S1 NO PLUMES	.000	.000	.000	.000	SREF	3155.0000	SO.FT.
(DBJ002)	AMPS 97-016 1A2 01 TO S1 PC/PT NOM. SRM A/A-8	.000	.000	.000	5.000	LREF	50.8000	FT.
(DBJ004)	AMPS 97-016 1A2 01 TO S1 PC/PT NOM. SRM A/A-8	.000	.000	.000	2.000	BREF	73.5000	FT.
(DBJ006)	AMPS 97-016 1A2 01 TO S1 PC/PT NOM	.000	.000	.000	3.000	XMRP	86.4167	FT.
						YMRP	.0000	FT.
						ZMRP	4.0000	FT.
						SCALE	.0190	

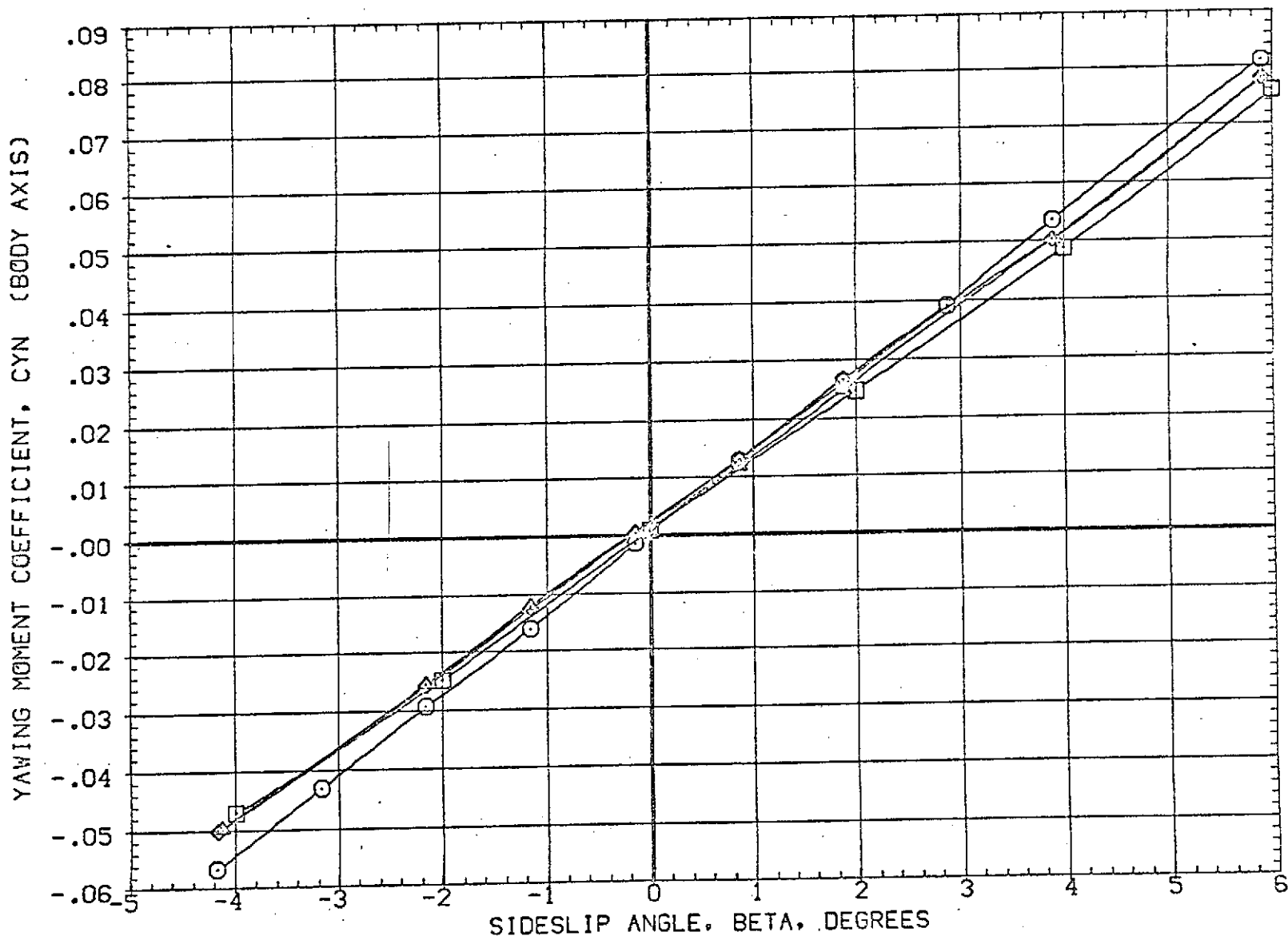

FIG 11 EFFECT OF ORBITER AND SRM PLUMES ON LATERAL CHARACTERISTICS, ALPHA=0.0

(A) MACH = 1.60

DATA SET SYMBOL	CONFIGURATION DESCRIPTION	ELEVON	AILRON	RUDDER	PLUMES	REFERENCE INFORMATION
(CB)502)	AMES 97-616 1A2 01 TO S1 NO PLUMES	.000	.000	.000	.000	SREF 3155.0000 SQ.FT.
(IB)002)	AMES 97-616 1A2 01 TO S1 PC/PT NOM. SRM A/A=8	.000	.000	.000	5.000	LREF 50.8000 FT.
(RB)004)	AMES 97-616 1A2 01 TO S1 PC/PT NOM. SRM A/A=8	.000	.000	.000	2.000	BREF 73.5000 FT.
(CB)006)	AMES 97-616 1A2 01 TO S1 PC/PT NOM	.000	.000	.000	3.000	XMRP 88.4167 FT. YMRP .0000 FT. ZMRP 4.0000 FT. SCALE .0190

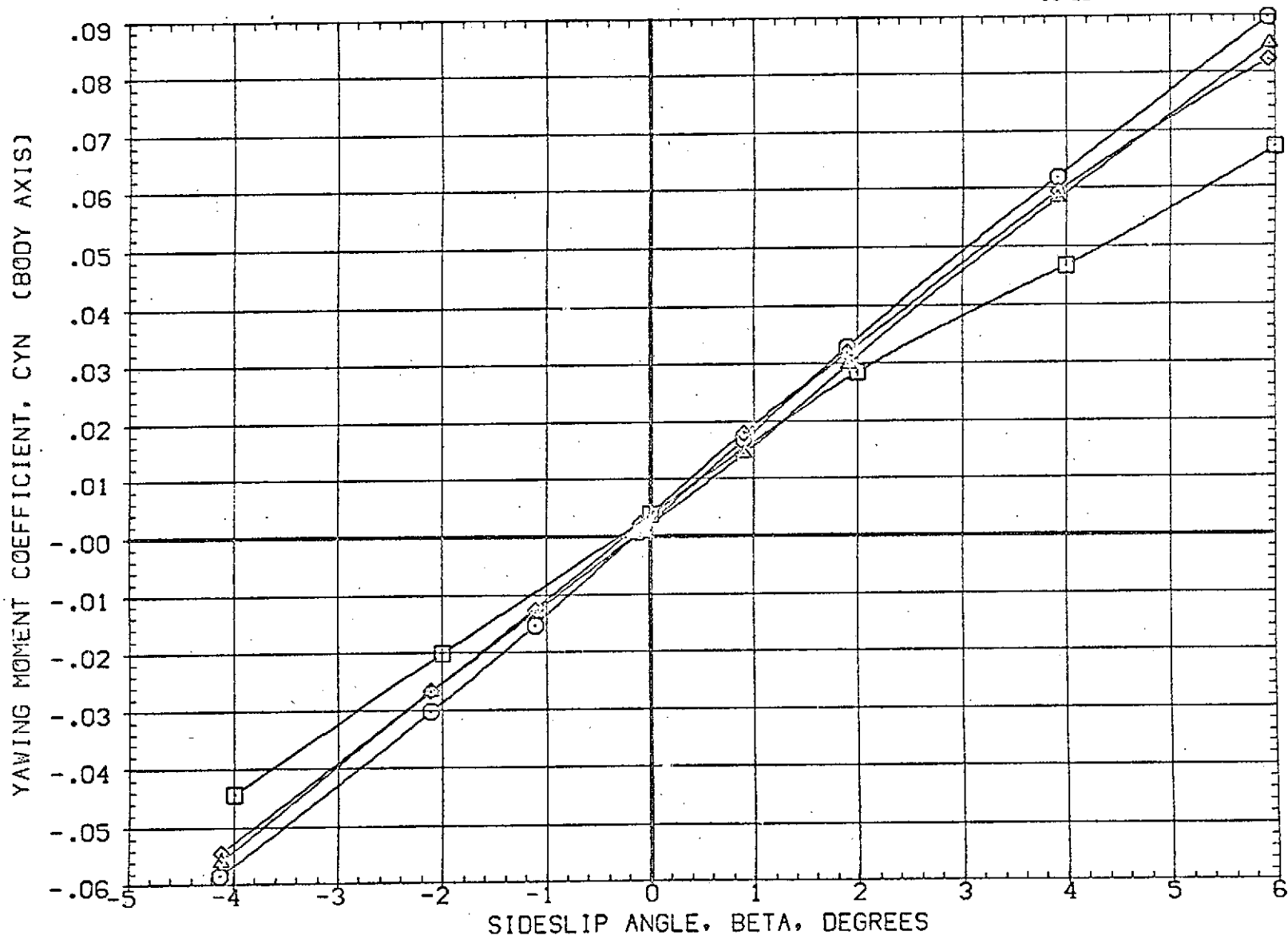

FIG 11 EFFECT OF ORBITER AND SRM PLUMES ON LATERAL CHARACTERISTICS, ALPHA=0.0

(B)MACH = 1.98

DATA SET SYMBOL	CONFIGURATION DESCRIPTION	ELEVON	AILERON	RUDDER	PLUMES	REFERENCE INFORMATION	
(DBJ502)	AMES 97-616 IA2 01 TO SI NO PLUMES	.000	.000	.000	.000	SREF	3155.0000 SQ.FT.
(RBJ002)	AMES 97-616 IA2 01 TO SI PC/PT NOM. SRM A/A=8	.000	.000	.000	5.000	LREF	50.8000 FT.
(RBJ004)	AMES 97-616 IA2 01 TO SI PC/PT NOM. SRM A/A=8	.000	.000	.000	2.000	BREF	73.5000 FT.
(DBJ006)	AMES 97-616 IA2 01 TO SI PC/PT NOM	.000	.000	.000	3.000	XMRP	66.4167 FT.
						YMRP	.0000 FT.
						ZMRP	4.0000 FT.
						SCALE	.0190

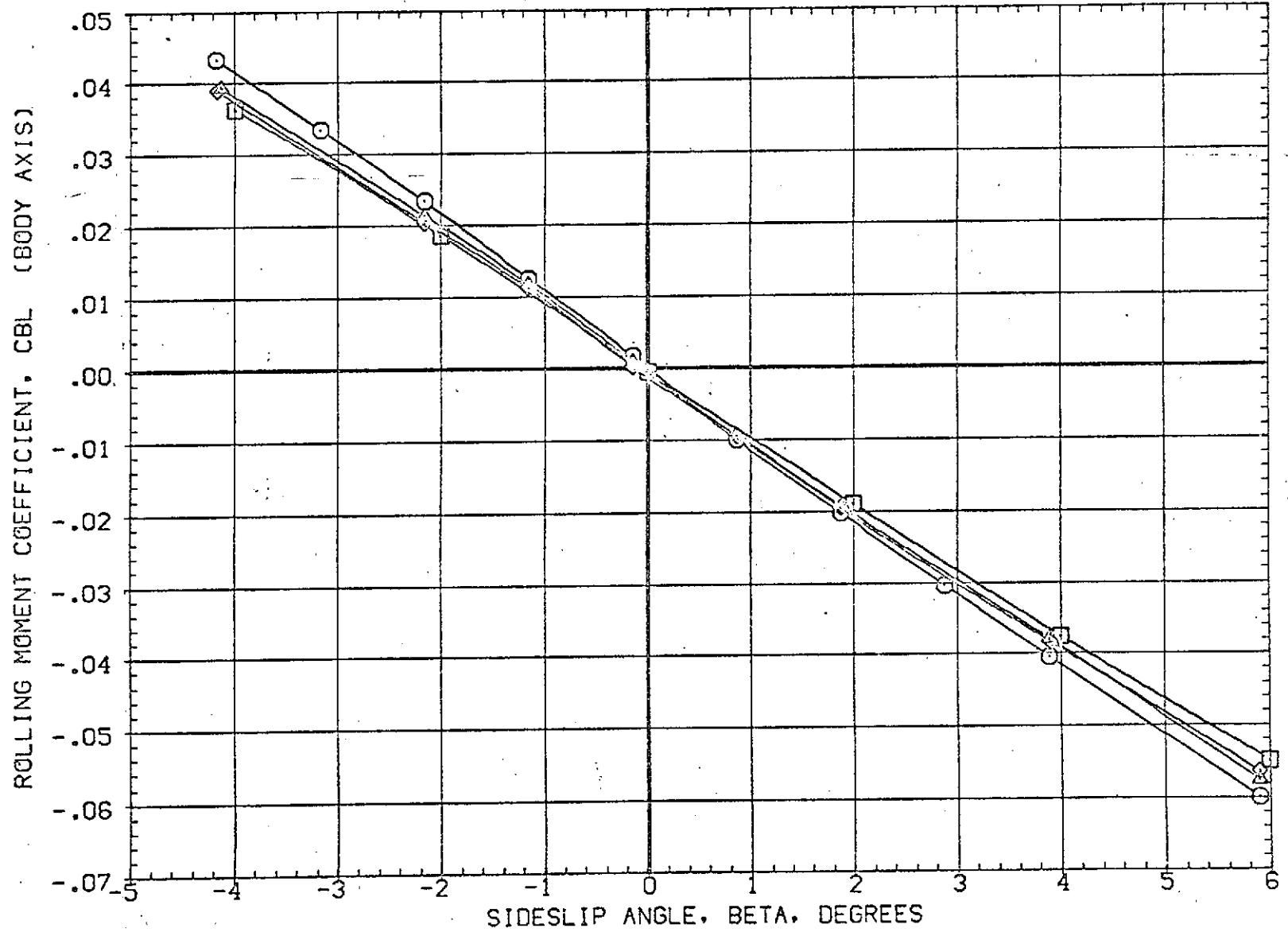

FIG 11 EFFECT OF ORBITER AND SRM PLUMES ON LATERAL CHARACTERISTICS, ALPHA=0.0

(A) MACH = 1.60

DATA SET SYMBOL	CONFIGURATION DESCRIPTION	ELEVON	AILERON	RUDDER	PLUMES	REFERENCE INFORMATION		
(DBJ502)	AMES 97-616 1A2 01 TO S1 NO PLUMES	.000	.000	.000	.000	SREF	3155.0000	SQ.FT.
(IBJ002)	AMES 97-616 1A2 01 TO S1 PC/PT NOM, SRM A/A-8	.000	.000	.000	5.000	LREF	50.8000	FT.
(RBJ004)	AMES 97-616 1A2 01 TO S1 PC/PT NOM, SRM A/A-8	.000	.000	.000	2.000	BREF	73.5000	FT.
(DBJ006)	AMES 97-616 1A2 01 TO S1 PC/PT NOM	.000	.000	.000	3.000	XM RP	86.4167	FT.
						YM RP	.0000	FT.
						ZM RP	4.0000	FT.
						SCALE	.0190	

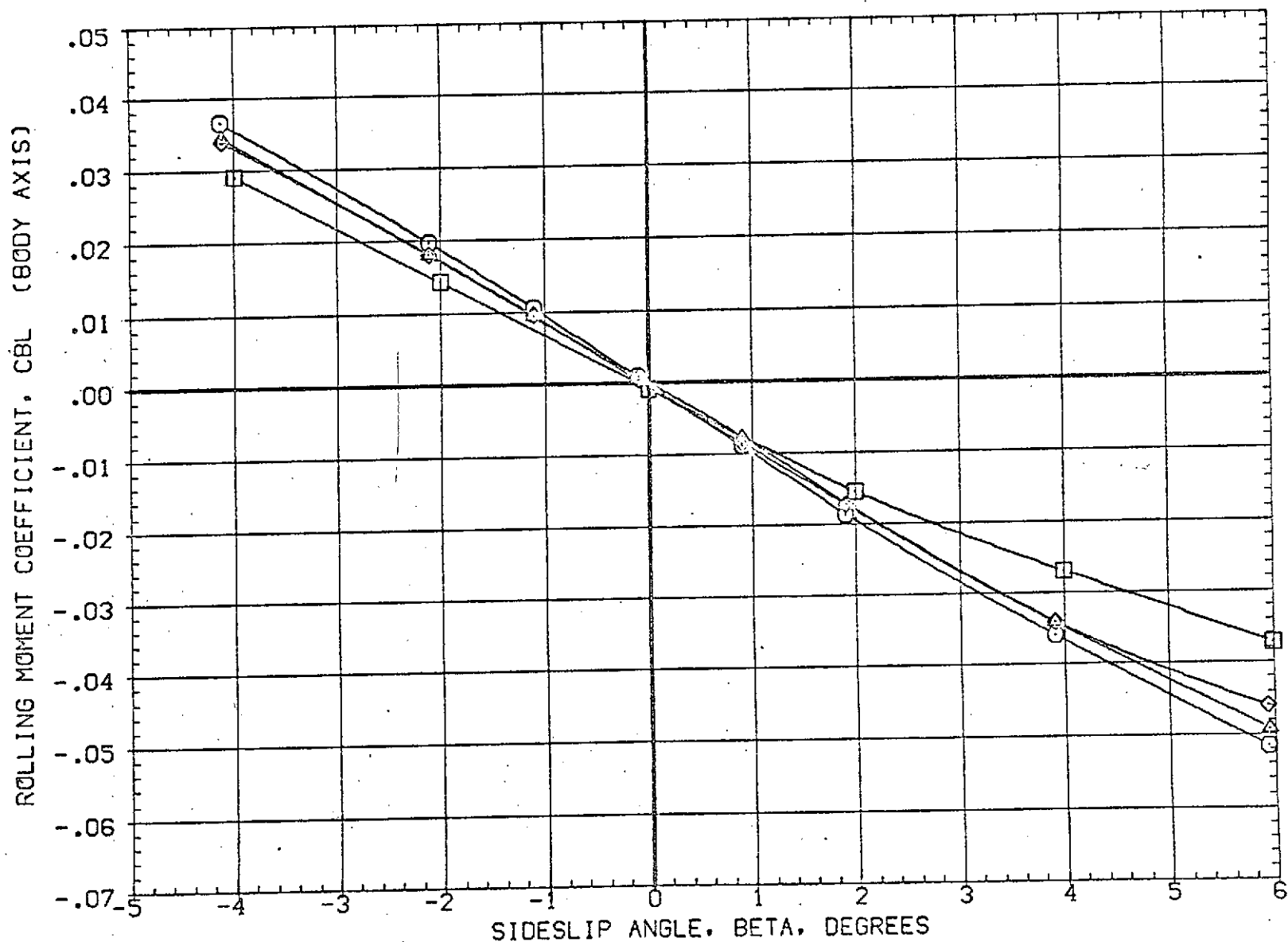

FIG 11 EFFECT OF ORBITER AND SRM PLUMES ON LATERAL CHARACTERISTICS, ALPHA=0.0
 (B)MACH = 1.98

DATA SET SYMBOL	CONFIGURATION DESCRIPTION	ELEVON	AILRON	RUDDER	PLUMES	REFERENCE INFORMATION
(OBJ502)	AMES 97-616 1A2 01 TO S1 NO PLUMES	.000	.000	.000	.000	SREF 3155.0000 SQ.FT.
(OBJ002)	AMES 97-616 1A2 01 TO S1 PC/PT NOM, SRM A/A=8	.000	.000	.000	5.000	LREF 50.8000 FT.
(OBJ004)	AMES 97-616 1A2 01 TO S1 PC/PT NOM, SRM A/A=8	.000	.000	.000	2.000	BREF 73.5000 FT.
(OBJ006)	AMES 97-616 1A2 01 TO S1 PC/PT NOM	.000	.000	.000	3.000	XMRP 86.4167 FT.
						YMRP .0000 FT.
						ZMRP 4.0000 FT.
						SCALE .0190

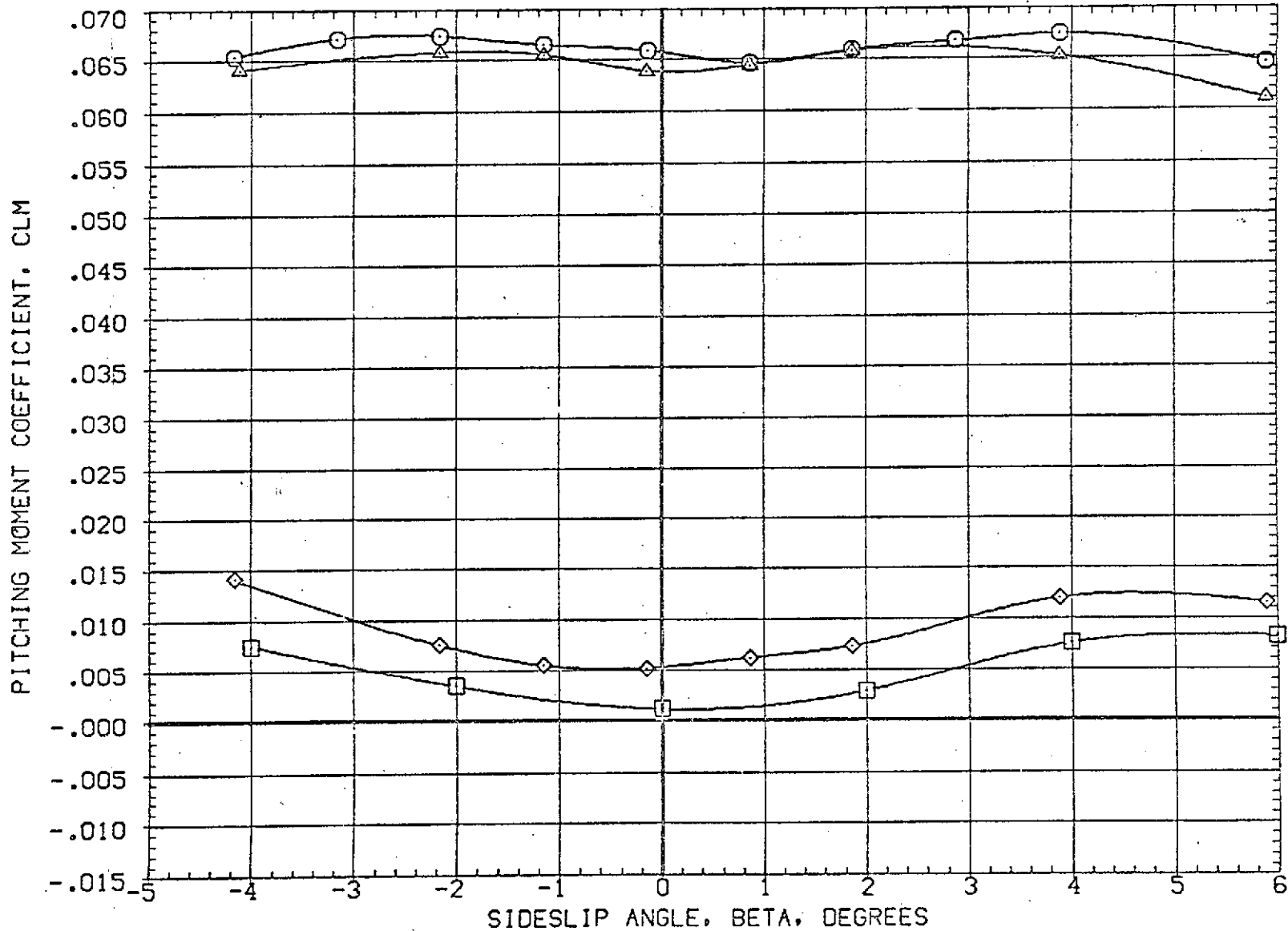

FIG 11 EFFECT OF ORBITER AND SRM PLUMES ON LATERAL CHARACTERISTICS, ALPHA=0.0

(A) MACH = 1.60

DATA SET SYMBOL	CONFIGURATION DESCRIPTION	ELEVON	AILRON	RUDDER	PLUMES	REFERENCE INFORMATION	
(DBJ502)	AMES 97-616 1A2 01 TO S1 NO PLUMES	.000	.000	.000	.000	SREF	3155.0000 SQ.FT.
(TSJ002)	AMES 97-616 1A2 01 TO S1 PC/PT NOM. SRM A/A=8	.000	.000	.000	5.000	LREF	50.8000 FT.
(RSJ004)	AMES 97-616 1A2 01 TO S1 PC/PT NOM. SRM A/A=8	.000	.000	.000	2.000	BREF	73.5000 FT.
(DBJ006)	AMES 97-616 1A2 01 TO S1 PC/PT NOM	.000	.000	.000	3.000	XMRP	86.4167 FT.
						YMRP	.0000 FT.
						ZMRP	4.0000 FT.
						SCALE	.0190

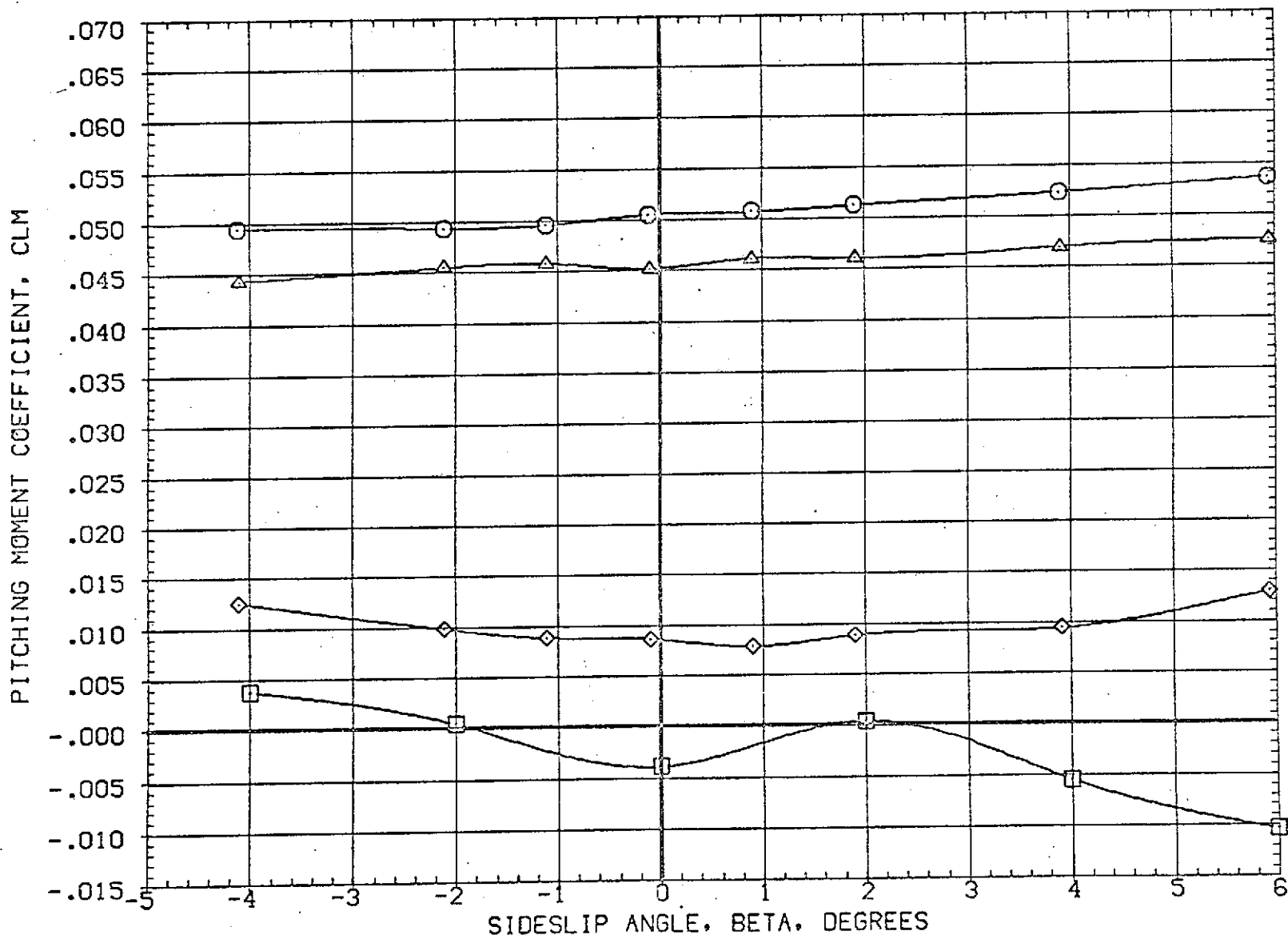

FIG 11 EFFECT OF ORBITER AND SRM PLUMES ON LATERAL CHARACTERISTICS, ALPHA=0.0

(B)MACH = 1.98

DATA SET SYMBOL	CONFIGURATION DESCRIPTION
(DBJ502)	AMES 97-616 1A2 01 TO S1 NO PLUMES
(DBJ002)	AMES 97-616 1A2 01 TO S1 PC/PT NOM, SRM A/A=8
(DBJ004)	AMES 97-616 1A2 01 TO S1 PC/PT NOM, SRM A/A=8
(DBJ006)	AMES 97-616 1A2 01 TO S1 PC/PT NOM

ELEVON	AILRON	RUDDER	PLUMES	REFERENCE INFORMATION	
.000	.000	.000	.000	SREF	3155.0000 SQ.FT.
.000	.000	.000	5.000	LREF	50.8000 FT.
.000	.000	.000	2.000	BREF	73.5000 FT.
.000	.000	.000	3.000	XMRP	86.4167 FT.
				YMRP	.0000 FT.
				ZMRP	4.0000 FT.
				SCALE	.0190

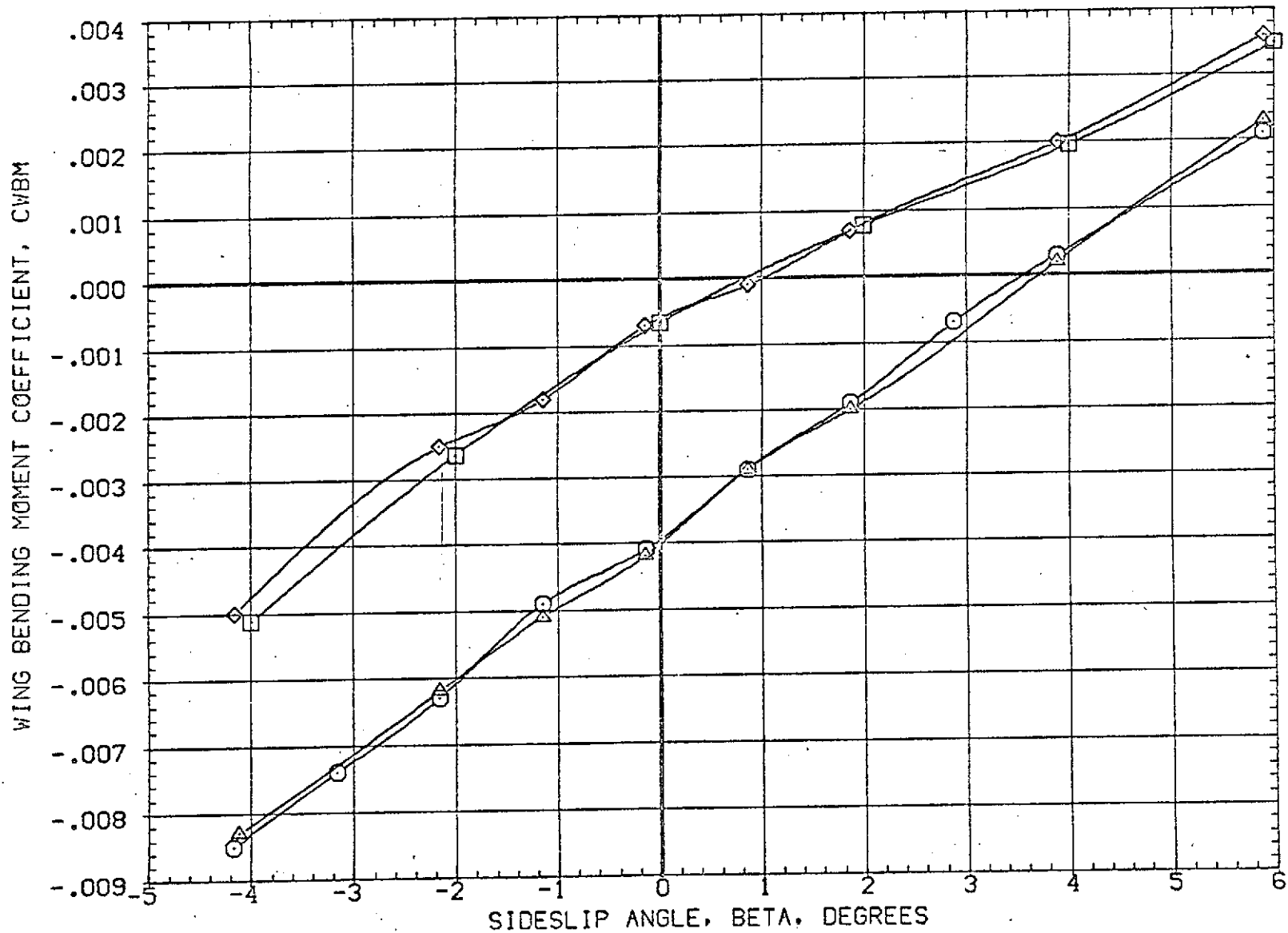

FIG 11 EFFECT OF ORBITER AND SRM PLUMES ON LATERAL CHARACTERISTICS, ALPHA=0.0

(A) MACH = 1.60

DATA SET SYMBOL	CONFIGURATION DESCRIPTION	ELEVON	AILERON	RUDDER	PLUMES	REFERENCE INFORMATION		
(DBJ502)	AMES 97-616 IA2 01 TO S1 NO PLUMES	.000	.000	.000	.000	SREF	3155.0000	50.FT.
(HBJ002)	AMES 97-616 IA2 01 TO S1 PC/PT NOM,SRM A/A=8	.000	.000	.000	5.000	LREF	50.8000	FT.
(RBJ004)	AMES 97-616 IA2 01 TO S1 PC/PT NOM,SRM A/A=8	.000	.000	.000	2.000	BREF	73.5000	FT.
(DBJ006)	AMES 97-616 IA2 01 TO S1 PC/PT NOM	.000	.000	.000	3.000	XMRP	86.4167	FT.
						YMRP	.0000	FT.
						ZMRP	4.0000	FT.
						SCALE	.0190	

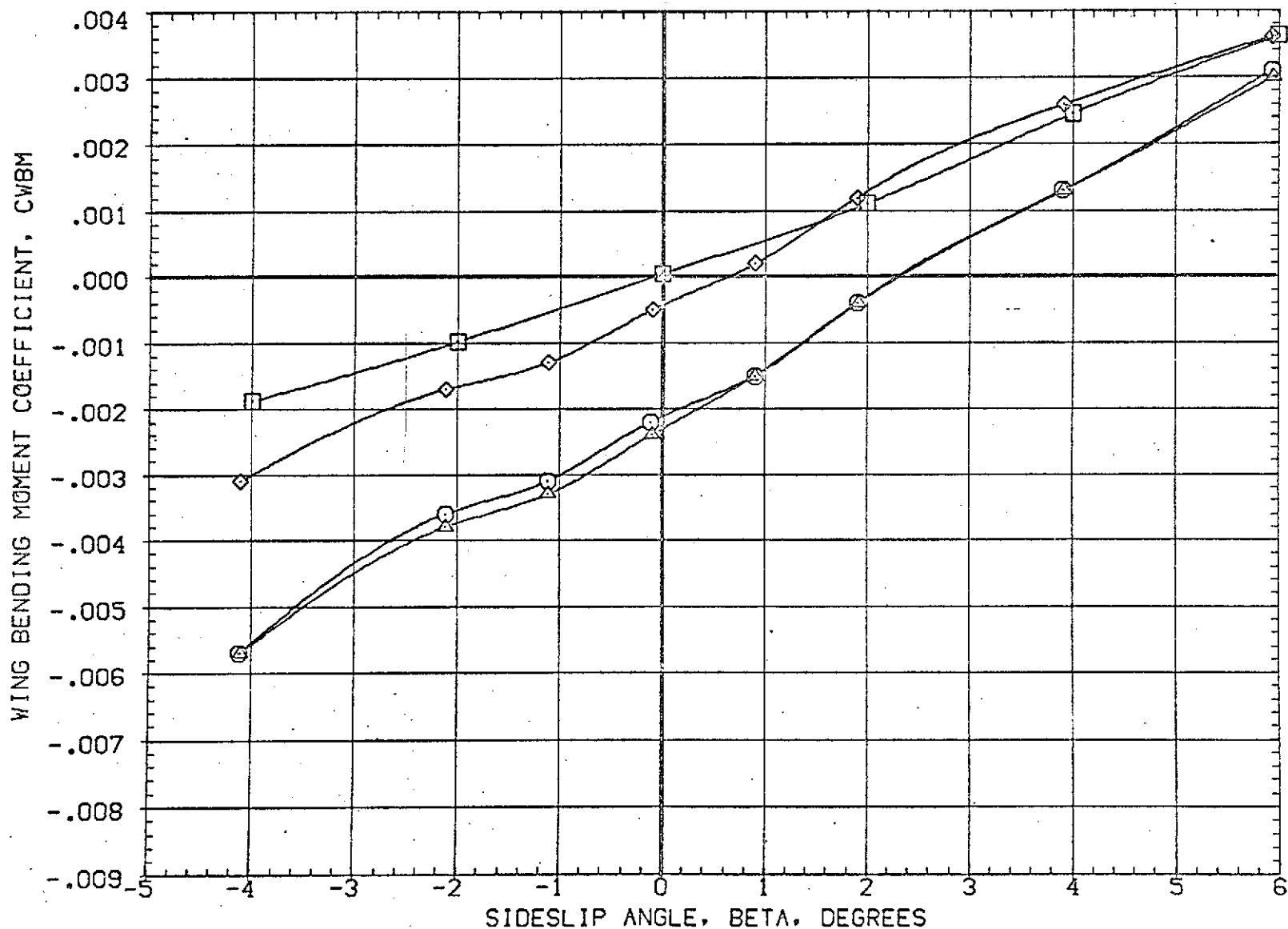

FIG 11 EFFECT OF ORBITER AND SRM PLUMES ON LATERAL CHARACTERISTICS, ALPHA=0.0

DATA SET SYMBOL	CONFIGURATION DESCRIPTION	ELEVON	AILRON	RUDDER	PLUMES	REFERENCE INFORMATION		
(D9J502)	AMES 97-616 1A2 01 TO S1 NO PLUMES	.000	.000	.000	.000	SREF	3155.0000	SQ.FT.
(H9J002)	AMES 97-616 1A2 01 TO S1 PC/PT NGM. SRM A/A=B	.000	.000	.000	5.000	LREF	50.8000	FT.
(R9J004)	AMES 97-616 1A2 01 TO S1 PC/PT NGM. SRM A/A=B	.000	.000	.000	2.000	BREF	73.5000	FT.
(D9J006)	AMES 97-616 1A2 01 TO S1 PC/PT NGM	.000	.000	.000	3.000	XMRP	86.4167	FT.
						YMRP	.0000	FT.
						ZMRP	4.0000	FT.
						SCALE	.0190	

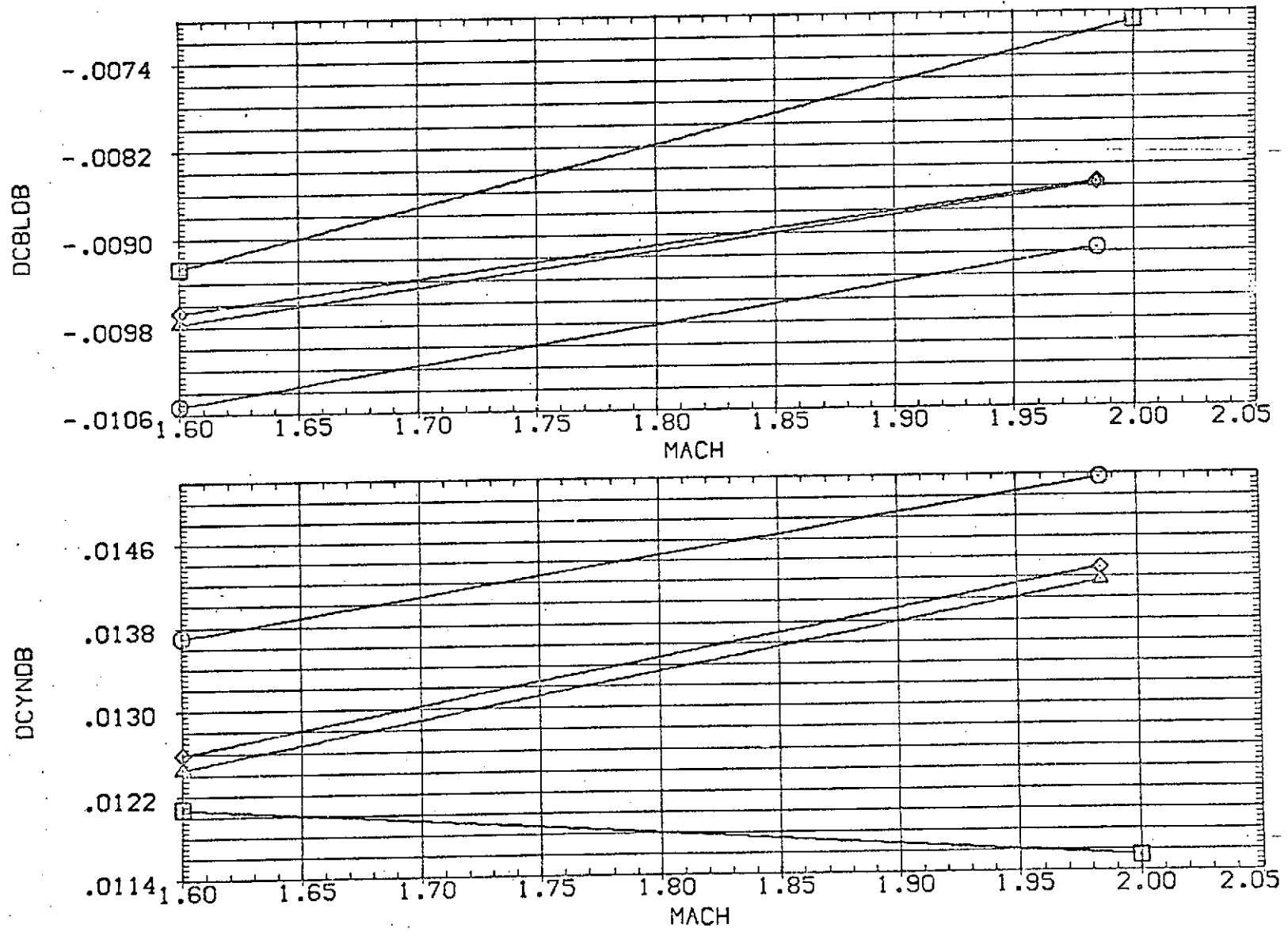

FIG 11 EFFECT OF ORBITER AND SRM PLUMES ON LATERAL CHARACTERISTICS, ALPHA=0.0

DATA SET SYMBOL	CONFIGURATION DESCRIPTION	ELEVON	AILERON	RUDDER	PLUMES	REFERENCE INFORMATION
(EBJ501)	AMES 97-616 (A2 01 TO S1) NO PLUMES	.000	.000	.000	.000	SREF 3155.0000 SQ.FT.
(EBJ003)	AMES 97-616 (A2 01 TO S1) PC/PT NGM SRM A/A=8	.000	.000	.000	2.000	LREF 50.8000 FT.
(RBJ536)	AMES 97-616 (A2 01 TO S1) M=1.4 SOLID SRM PLUME	.000	.000	.000	.000	BREF 73.5000 FT.
(RBJ541)	AMES 97-616 (A2 01 TO S1) M=1.6 SOLID SRM PLUME	.000	.000	.000	.000	XMRP 86.4167 FT. YMRP .0000 FT. ZMRP 4.0000 FT. SCALE .0190

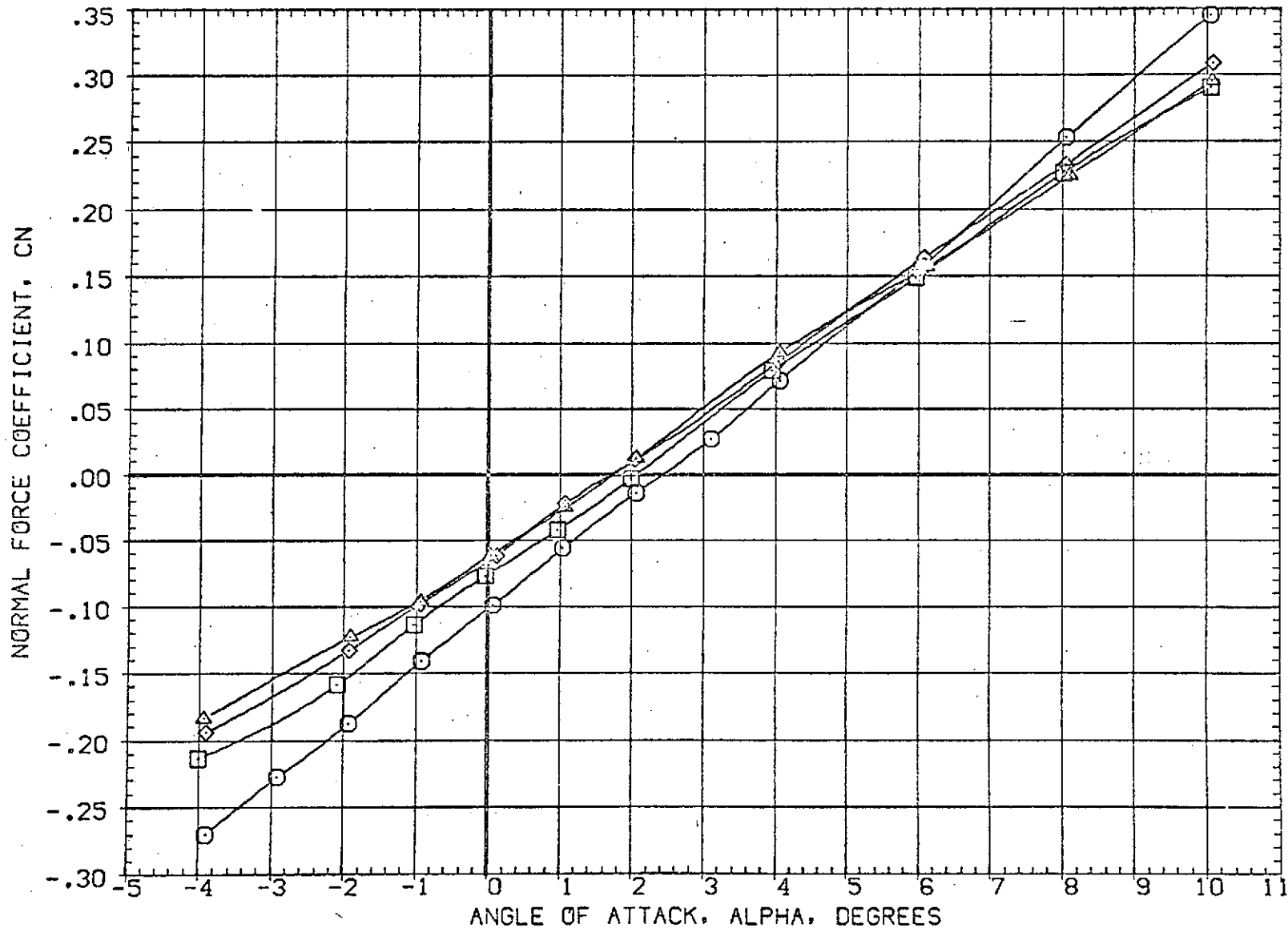

FIG 12 COMPARISON OF GASEOUS AND SOLID SRM PLUMES

(A)MACH = 1.60

DATA SET SYMBOL	SYMBOL	CONFIGURATION DESCRIPTION	ELEVON	AILERON	RUDDER	PLUMES	REFERENCE INFORMATION
(EBJ501)	○	AMES 97-616 1A2 01 TO S1 NO PLUMES	.000	.000	.000	.000	SREF 3155.0000 SQ.FT.
(EBJ003)	□	AMES 97-616 1A2 01 TO S1 PC/PT NOM. SRM A/A=8	.000	.000	.000	2.000	LREF 50.8000 FT.
(RBJ536)	◇	AMES 97-616 1A2 01 TO S1 M=1.4 SOLID SRM PLUME	.000	.000	.000	.000	BREF 73.5000 FT.
(RBJ541)	△	AMES 97-616 1A2 01 TO S1 M=1.6 SOLID SRM PLUME	.000	.000	.000	.000	XMRP 86.4167 FT.
							YMRP .0000 FT.
							ZMRP 4.0000 FT.
							SCALE .0190

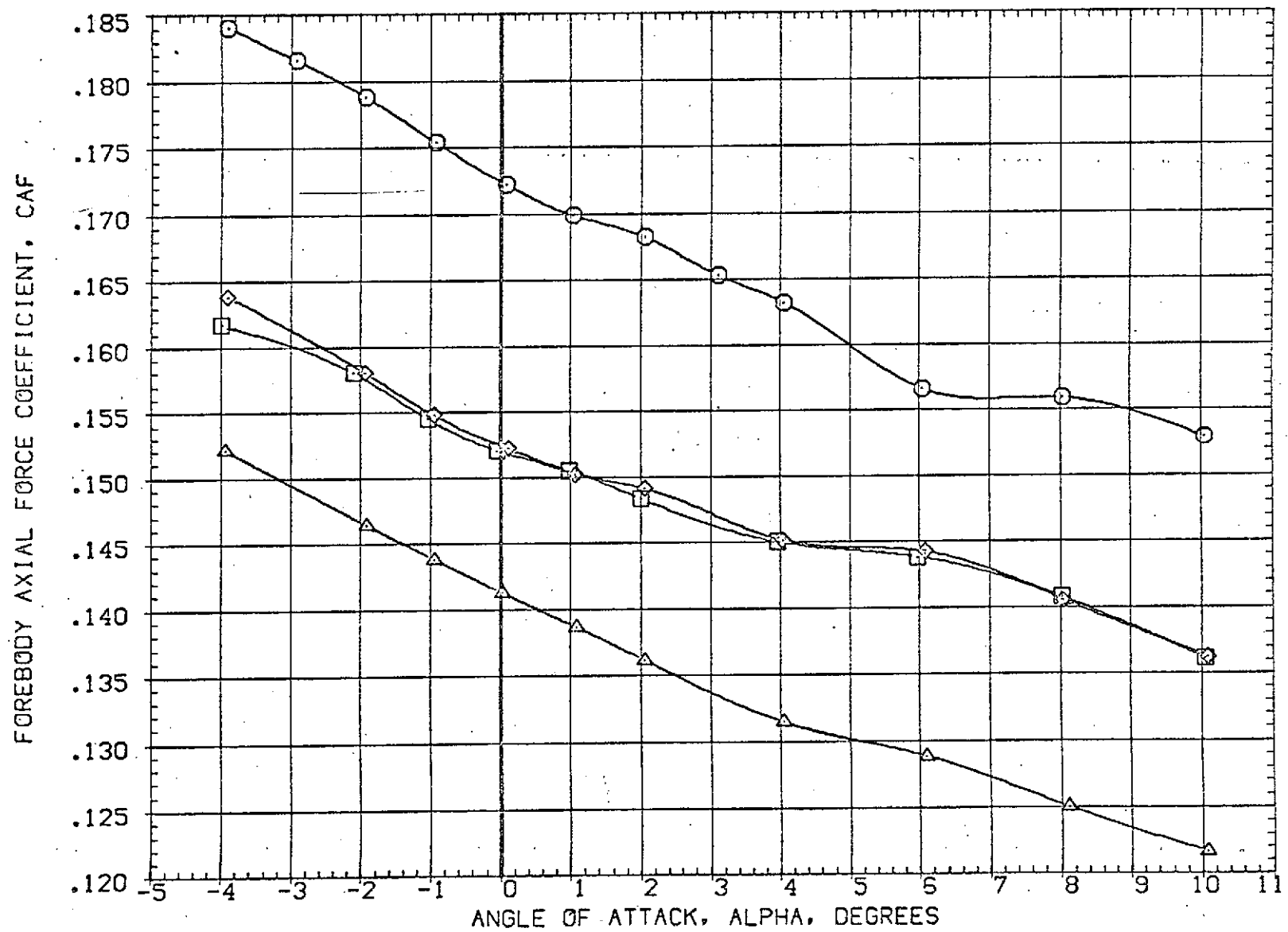

FIG 12 COMPARISON OF GASEOUS AND SOLID SRM PLUMES

(A)MACH = 1.60

DATA SET SYMBOL	CONFIGURATION DESCRIPTION	ELEVON	AILRON	RUDDER	PLUMES	REFERENCE INFORMATION
(EBJ501)	AMES 97-616 IA2 01 TO S1 NO PLUMES	.000	.000	.000	.000	SREF 3155.0000 SQ.FT.
(EBJ003)	AMES 97-616 IA2 01 TO S1 PC/PT NOM. SRM A/A-8	.000	.000	.000	2.000	LREF 50.8000 FT.
(RBJ536)	AMES 97-616 IA2 01 TO S1 M=1.4 SOLID SRM PLUME	.000	.000	.000	.000	BREF 73.5000 FT.
(RBJ541)	AMES 97-616 IA2 01 TO S1 M=1.6 SOLID SRM PLUME	.000	.000	.000	.000	XMRP 86.4167 FT. YMRP .0000 FT. ZMRP 4.0000 FT. SCALE .0190

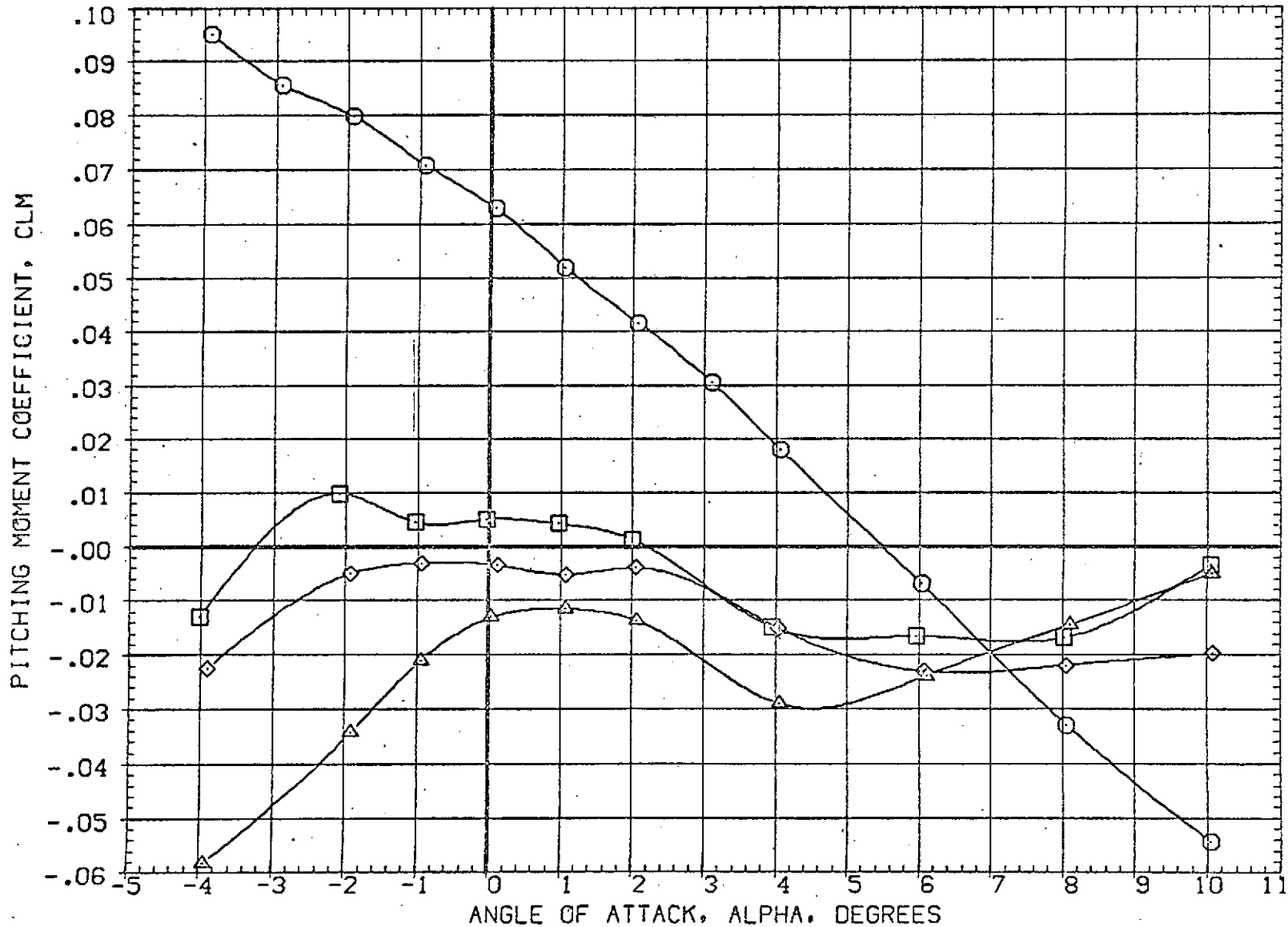

FIG 12 COMPARISON OF GASEOUS AND SOLID SRM PLUMES

(A)MACH = 1.60

DATA SET SYMBOL	CONFIGURATION DESCRIPTION	ELEVON	AILRON	RUDDER	PLUMES	REFERENCE INFORMATION	
(EBJ501)	AMES 97-616 1A2 01 TO S1 NO PLUMES	.000	.000	.000	.000	SREF	3155.0000 SQ.FT.
(EBJ003)	AMES 97-616 1A2 01 TO S1 PC/PT NOM. SRM A/A-B	.000	.000	.000	2.000	LREF	50.8000 FT.
(RBW535)	AMES 97-616 1A2 01 TO S1 M=1.4 SOLID SRM PLUME	.000	.000	.000	.000	BREF	73.5000 FT.
(RBW541)	AMES 97-616 1A2 01 TO S1 M=1.6 SOLID SRM PLUME	.000	.000	.000	.000	XMRP	86.4167 FT.
						YMRP	.0000 FT.
						ZMRP	4.0000 FT.
						SCALE	.0190

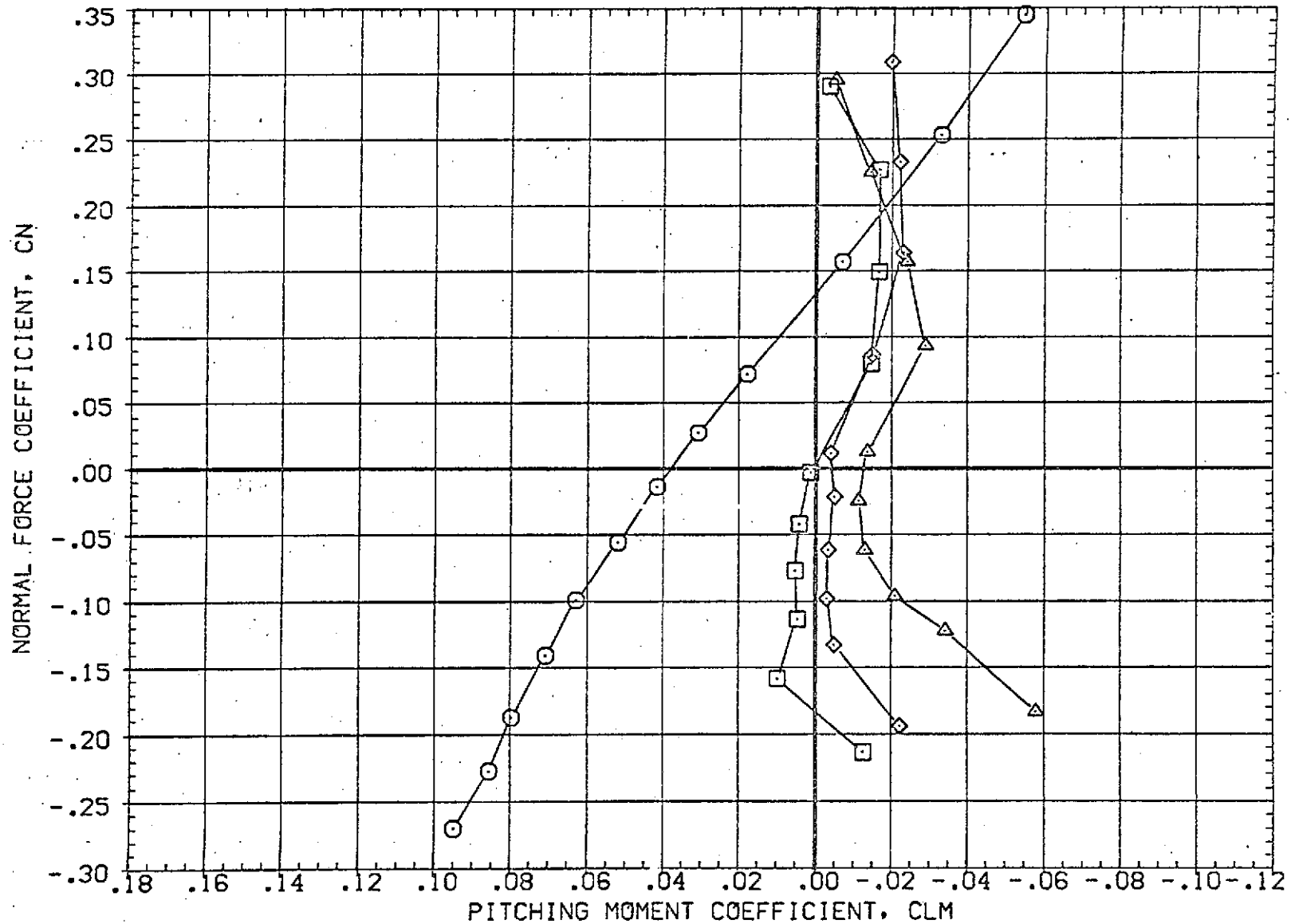

FIG 12 COMPARISON OF GASEOUS AND SOLID SRM PLUMES

(A) MACH = 1.60

DATA SET SYMBOL	CONFIGURATION DESCRIPTION	ELEVON	AILERON	RUDDER	PLUMES	REFERENCE INFORMATION		
(EBJ501)	AMES 97-616 1A2 01 TO S1 NO PLUMES	.000	.000	.000	.000	SREF	3155.0000	50. FT.
(EBJ003)	AMES 97-616 1A2 01 TO S1 PC/PT NOM. SRM A/A=8	.000	.000	.000	2.000	LREF	50.8000	FT.
(RBJ536)	AMES 97-616 1A2 01 TO S1 M=1.4 SOLID SRM PLUME	.000	.000	.000	.000	BREF	73.5000	FT.
(RBJ541)	AMES 97-616 1A2 01 TO S1 M=1.6 SOLID SRM PLUME	.000	.000	.000	.000	XMRP	96.4167	FT.
						YMRP	.0000	FT.
						ZMRP	4.0000	FT.
						SCALE	.0150	

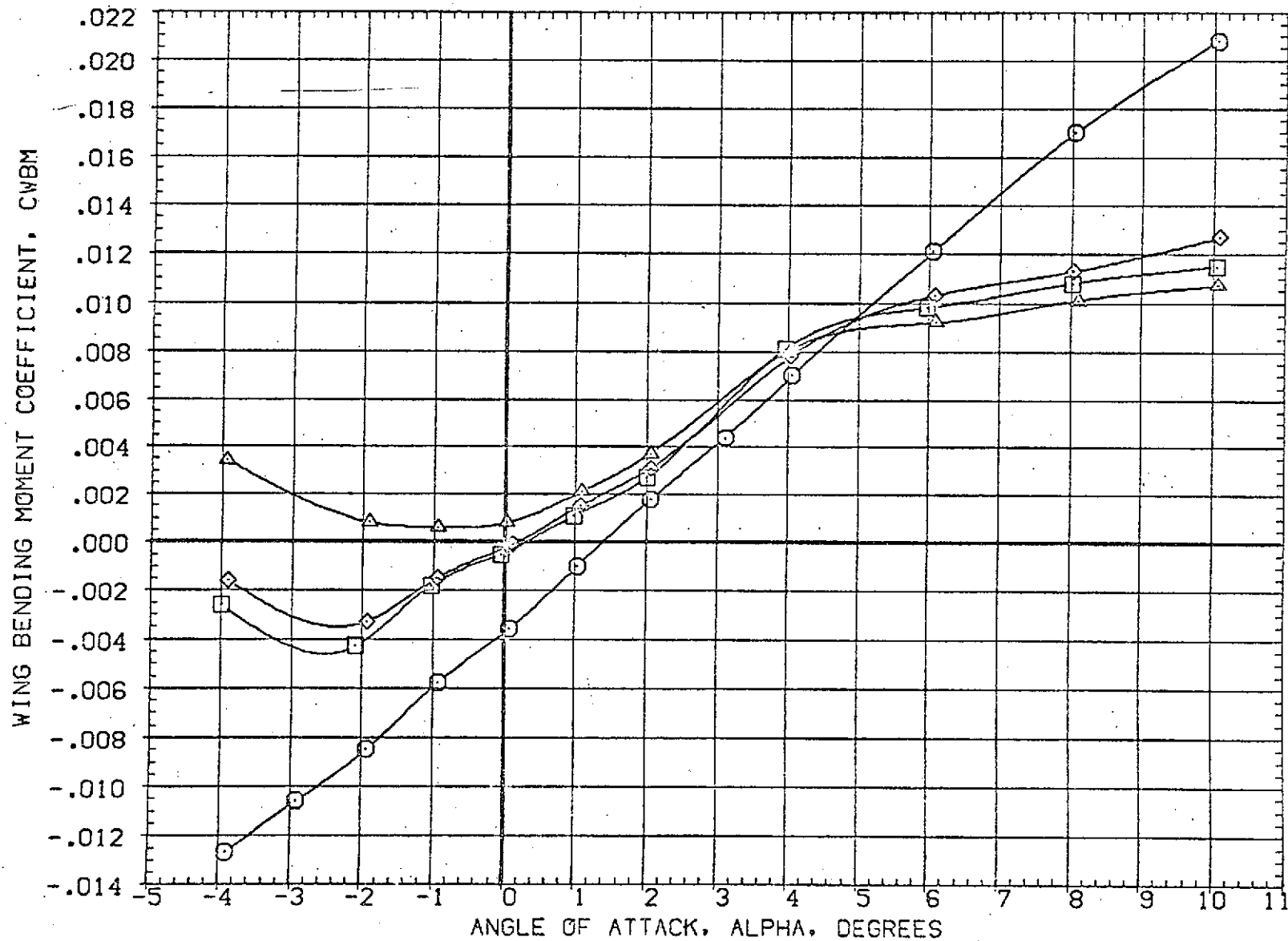

FIG 12 COMPARISON OF GASEOUS AND SOLID SRM PLUMES

(A) MACH = 1.60

DATA SET SYMBOL	CONFIGURATION DESCRIPTION	ELEVON	AILERON	RUDDER	PLUMES	REFERENCE INFORMATION
(EBJS02)	AMES 97-616 (A2 01 TO S1) NO PLUMES	.000	.000	.000	.000	SREF 3155.0000 SQ.FT.
(EBJ004)	AMES 97-616 (A2 01 TO S1) PC/PT NOM. SRM A/A=8	.000	.000	.000	2.000	LREF 50.8000 FT.
(RBJ538)	AMES 97-616 (A2 01 TO S1) M=1.4 SOLID SRM PLUME	.000	.000	.000	.000	BREF 73.5000 FT.
(RBJ542)	AMES 97-616 (A2 01 TO S1) M=1.6 SOLID SRM PLUME	.000	.000	.000	.000	XMRP 86.4167 FT.
						YMRP .0000 FT.
						ZMRP 4.0000 FT.
						SCALE .0190

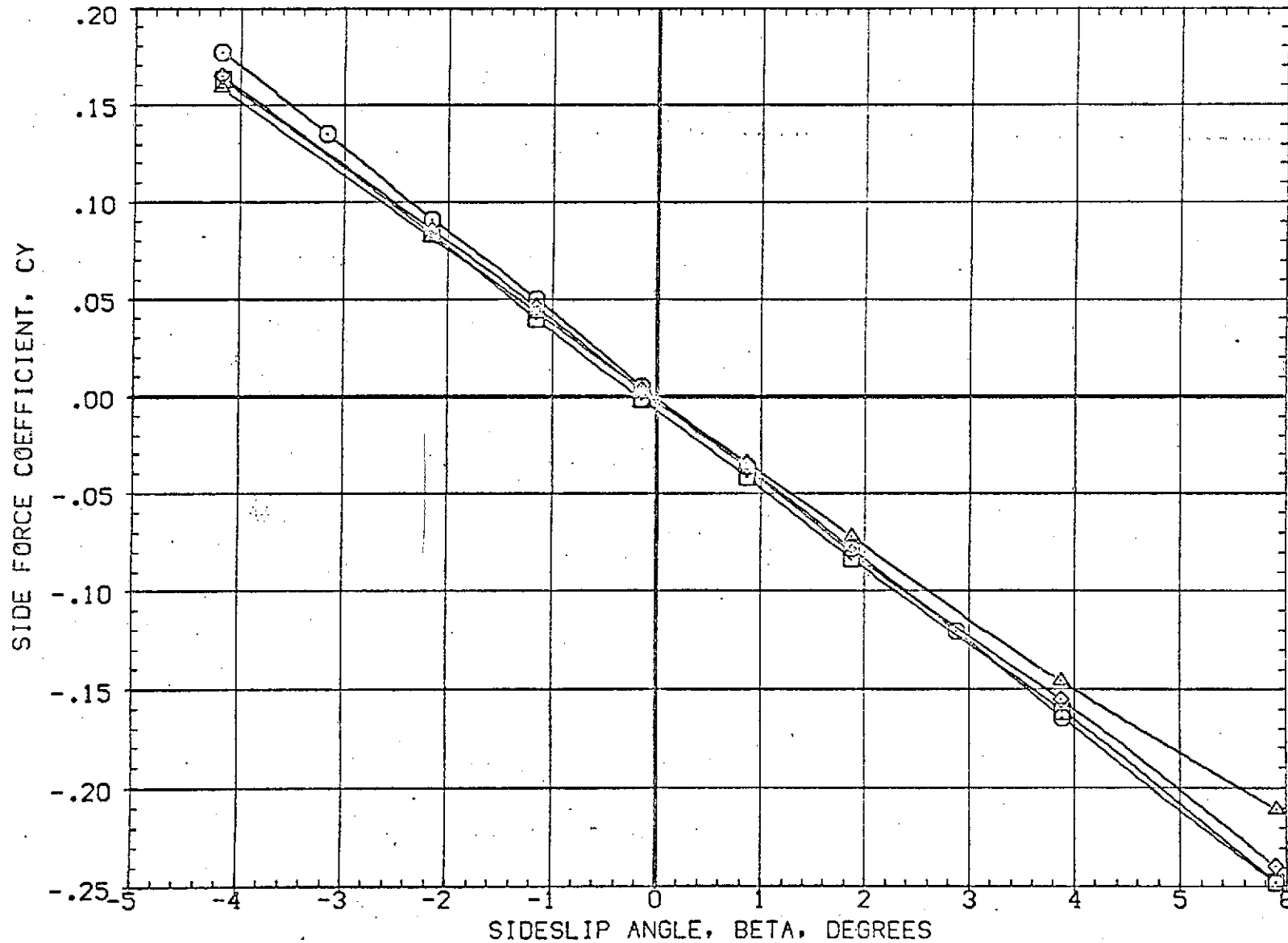

FIG 12. COMPARISON OF GASEOUS AND SOLID SRM PLUMES

(A) MACH = 1.60

DATA SET SYMBOL	CONFIGURATION DESCRIPTION	ELEVON	AILRON	RUDDER	PLUMES	REFERENCE INFORMATION
(EBJ502)	AMES 97-616 1A2 01 TO S1 NO PLUMES	.000	.000	.000	.000	SREF 3155.0000 SQ.FT.
(EBJ004)	AMES 97-616 1A2 01 TO S1 PC/PT NOM. SRM A/A=8	.000	.000	.000	2.000	LREF 50.8000 FT.
(RBJ536)	AMES 97-616 1A2 01 TO S1 M=1.4 SOLID SRM PLUME	.000	.000	.000	.000	BREF 73.5000 FT.
(RBJ542)	AMES 97-616 1A2 01 TO S1 M=1.6 SOLID SRM PLUME	.000	.000	.000	.000	XMRP 86.4167 FT. YMRP .0000 FT. ZMRP 4.0000 FT. SCALE .0190

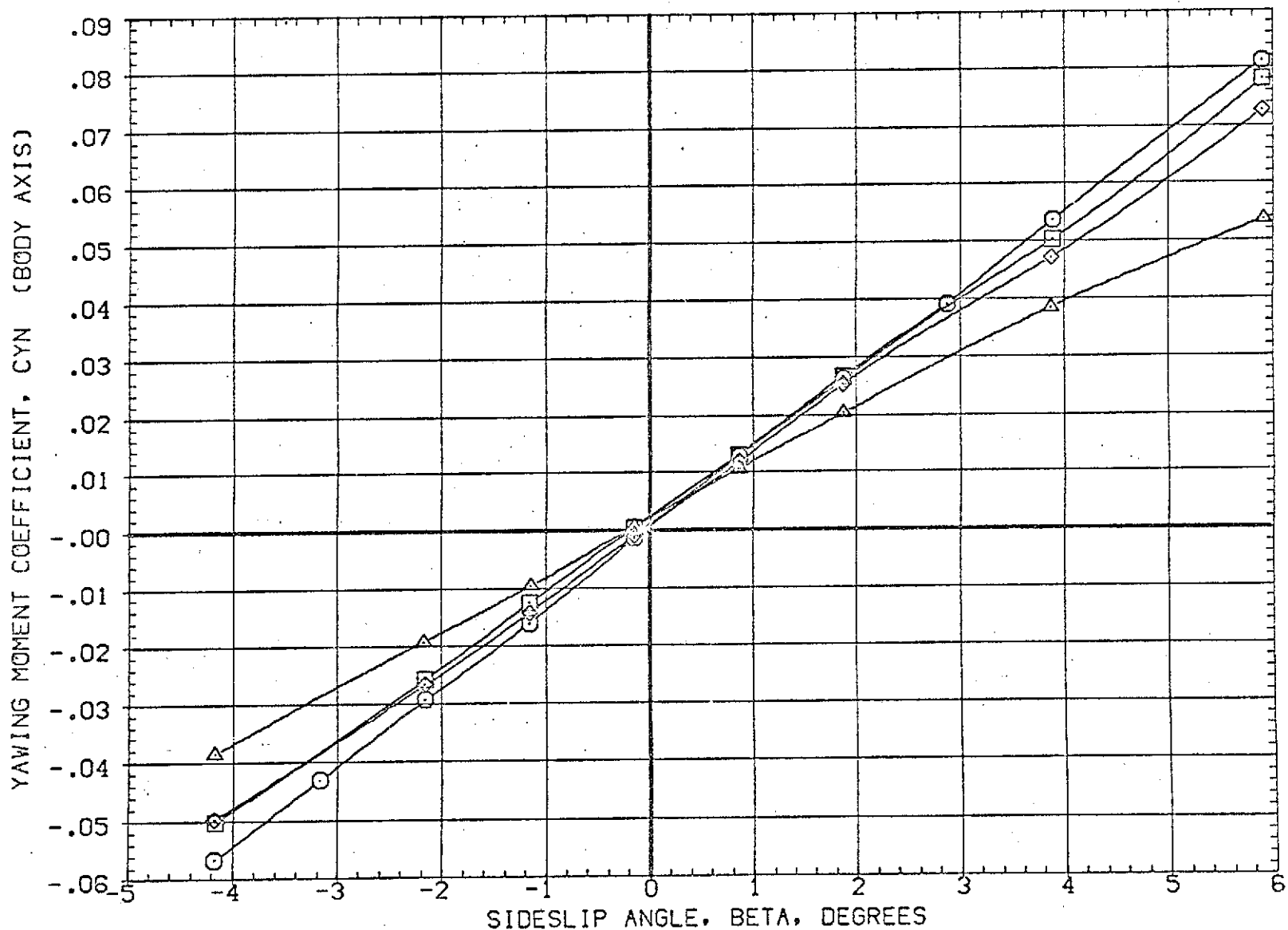

FIG 12 COMPARISON OF GASEOUS AND SOLID SRM PLUMES

(A)MACH = 1.60

DATA SET	SYMBOL	CONFIGURATION	IDENTIFICATION									
(RBV502)	○	AMES 97-616	IA2 01 TO S1	NO PLUMES	.000	.000	.000	.000	SREF	3155.0000	IN.FT.	
(RBV504)	□	AMES 97-616	IA2 01 TO S1	PC/PT NOM. SRM A/A=8	.000	.000	.000	2.000	LREF	50.8000	FT.	
(RBV539)	◇	AMES 97-616	IA2 01 TO S1	M=1.4 SOLID SRM PLUME	.000	.000	.000	.000	BREF	73.5000	FT.	
(RBV542)	△	AMES 97-616	IA2 01 TO S1	M=1.6 SOLID SRM PLUME	.000	.000	.000	.000	XMRP	86.4167	FT.	
									YMRP	.0000	FT.	
									ZMRP	4.0000	FT.	
									SCALE	.0190		

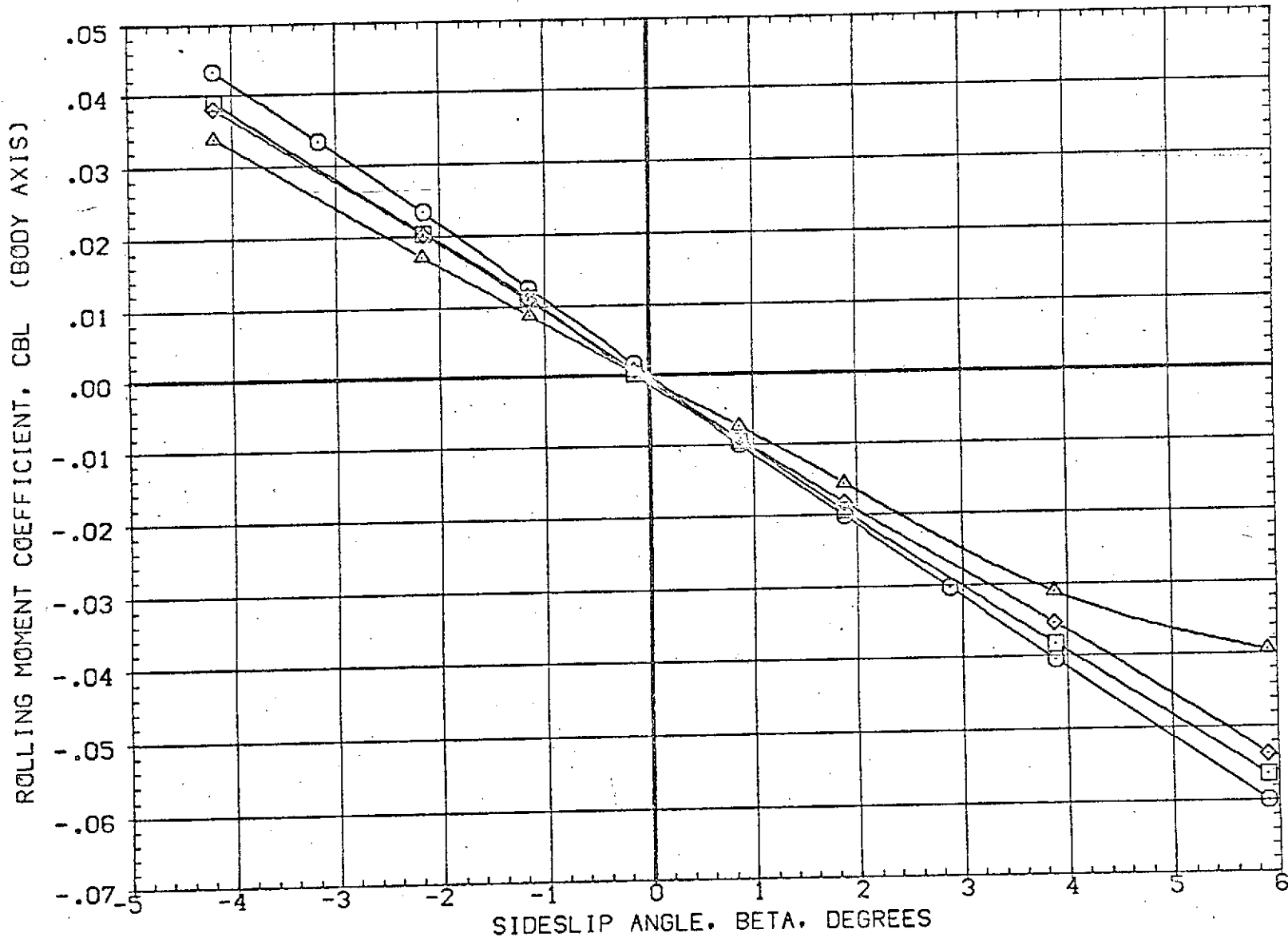

FIG 12 COMPARISON OF GASEOUS AND SOLID SRM PLUMES
(A)MACH = 1.60

DATA SET SYMBOL	CONFIGURATION DESCRIPTION	ELEVON	AILERON	RUDDER	PLUMES	REFERENCE INFORMATION
(EBJ502)	○ AMES 97-616 1A2 01 TO S1 NO PLUMES	.000	.000	.000	.000	SREF 3155.0000 SQ.FT.
(EBJ004)	□ AMES 97-616 1A2 01 TO S1 PC/PT NOM. SRM A/A=8	.000	.000	.000	2.000	LREF 50.8000 FT.
(RBJ538)	◇ AMES 97-616 1A2 01 TO S1 M=1.4 SOLID SRM PLUME	.000	.000	.000	.000	BREF 73.5000 FT.
(RBJ542)	△ AMES 97-616 1A2 01 TO S1 M=1.6 SOLID SRM PLUME	.000	.000	.000	.000	XMRP 86.4167 FT.
						YMRP .0000 FT.
						ZMRP 4.0000 FT.
						SCALE .0190

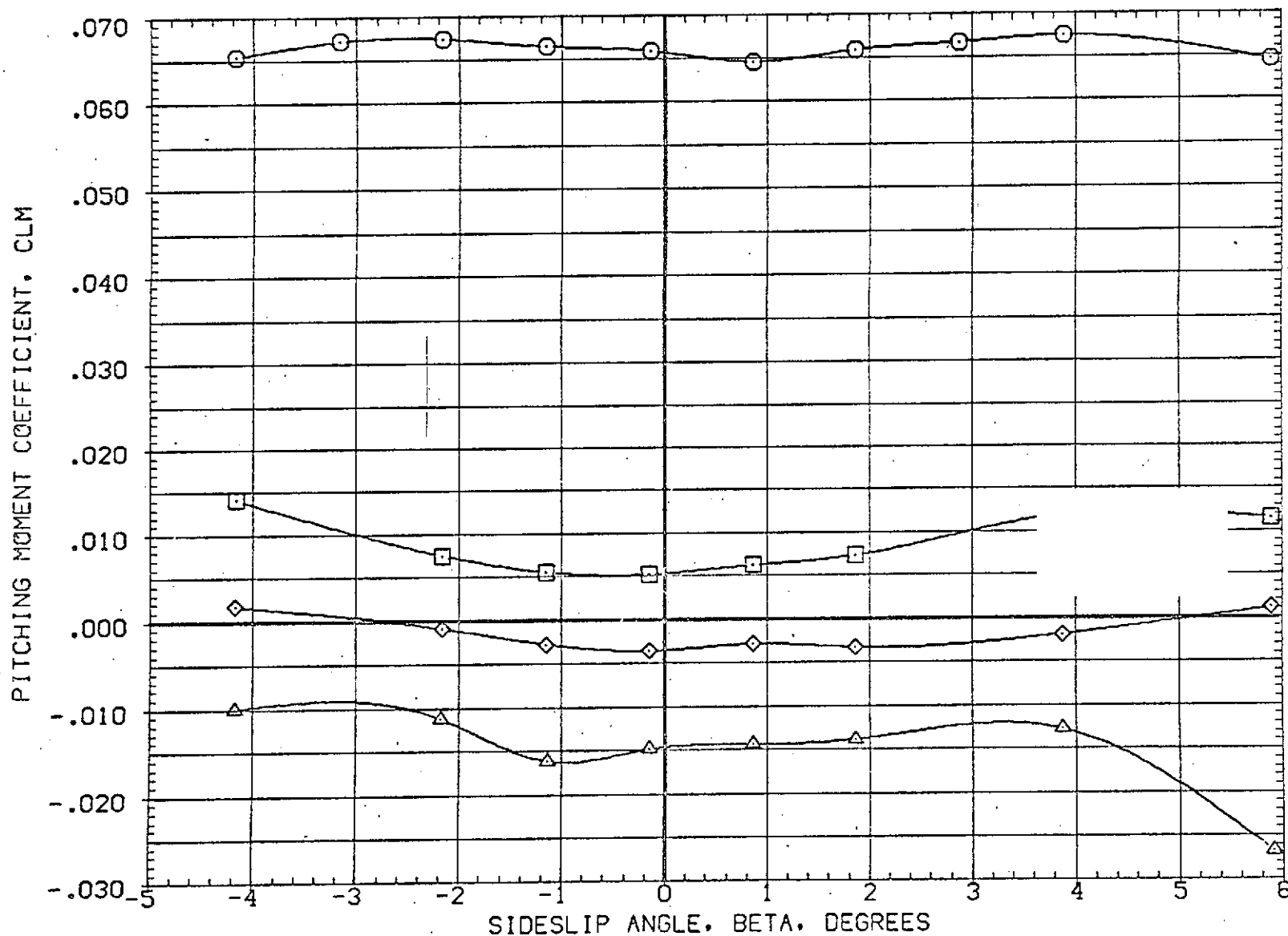

FIG 12 COMPARISON OF GASEOUS AND SOLID SRM PLUMES

(A)MACH = 1.60

DATA SET SYMBOL	CONFIGURATION DESCRIPTION	ELEVON	AILRON	RUDDER	PLUMES	REFERENCE INFORMATION		
(EBJ502)	AMES 97-616 1A2 01 TO S1 NO PLUMES	.000	.000	.000	.000	SREF	3155.0000	50. FT.
(EBJ004)	AMES 97-616 1A2 01 TO S1 PC/PT NOM. SRM A/A-8	.000	.000	.000	2.000	LREF	50.8000	FT.
(RBJ538)	AMES 97-616 1A2 01 TO S1 M=1.4 SOLID SRM PLUME	.000	.000	.000	.000	BREF	73.5000	FT.
(RBJ542)	AMES 97-616 1A2 01 TO S1 M=1.6 SOLID SRM PLUME	.000	.000	.000	.000	XMRP	85.4167	FT.
						YMRP	.0000	FT.
						ZMRP	4.0000	FT.
						SCALE	.0190	

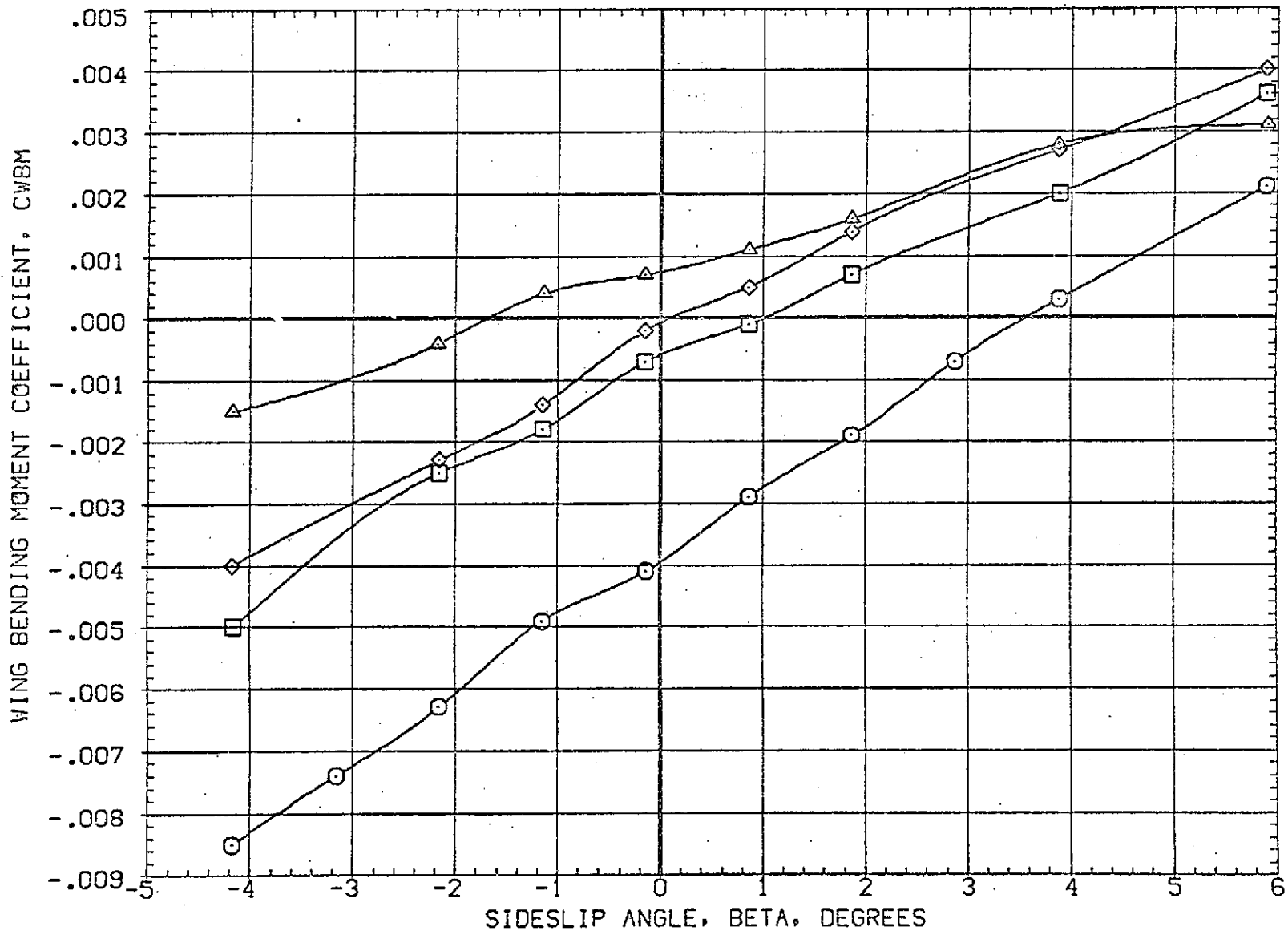

FIG 12 COMPARISON OF GASEOUS AND SOLID SRM PLUMES
 (A)MACH = 1.60

DATA SET SYMBOL	CONFIGURATION DESCRIPTION	ELEVON	AILRON	RUDDER	PLUMES	REFERENCE INFORMATION
(EBJ003)	AMES 97-616 1A2 01 TO S1 PC/PT NOM. SRM A/A=8	.000	.000	.000	2.000	SREF 3155.0000 SQ.FT
(EBJ013)	AMES 97-616 1A2 01 TO S1 PC/PT-NOM. SRM A/A=8	10.000	.000	10.000	2.000	LREF 50.8000 FT.
(RBJ536)	AMES 97-616 1A2 01 TO S1 M=1.4 SOLID SRM PLUME	.000	.000	.000	.000	BREF 73.5000 FT.
(RBJ539)	AMES 97-616 1A2 01 TO S1 M=1.4 SOLID SRM PLUME	10.000	.000	10.000	.000	XMRP 86.4167 FT.
						YMRP .0000 FT.
						ZMRP 4.0000 FT.
						SCALE .0190

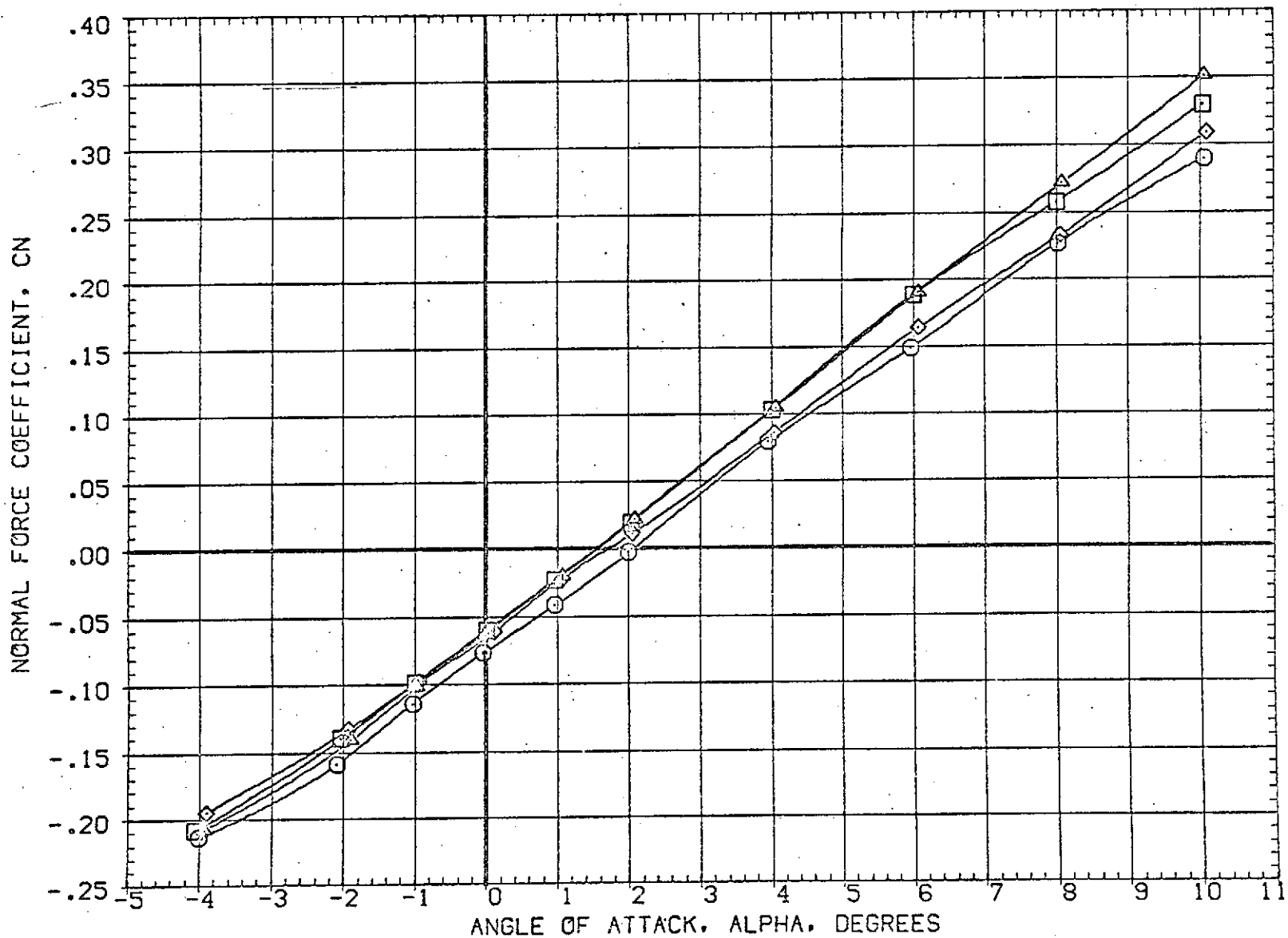

FIG 13 COMPARISON OF CONTROL EFFECTIVENESS WITH GASEOUS AND SOLID SRM PLUMES
 (A)MACH = 1.60

DATA SET SYMBOL	CONFIGURATION DESCRIPTION	ELEVON	AILRON	RUDDER	PLUMES	REFERENCE INFORMATION
(EBJ003)	AMES 97-616 IA2 01 TO S1 PC/RT NOM. SRM A/A=8	.000	.000	.000	2.000	SREF 3155.0000 SQ.FT.
(EBJ013)	AMES 97-616 IA2 01 TO S1 PC/PT=NOM. SRM A/A=8	10.000	.000	10.000	2.000	LREF 50.8000 FT.
(RBJ536)	AMES 97-616 IA2 01 TO S1 M=1.4 SOLID SRM PLUME	.000	.000	.000	.000	BREF 73.5000 FT.
(RBJ539)	AMES 97-616 IA2 01 TO S1 M=1.4 SOLID SRM PLUME	10.000	.000	10.000	.000	XMRP 86.4167 FT.
						YMRP 4.0000 FT.
						ZMRP 4.0000 FT.
						SCALE .0190

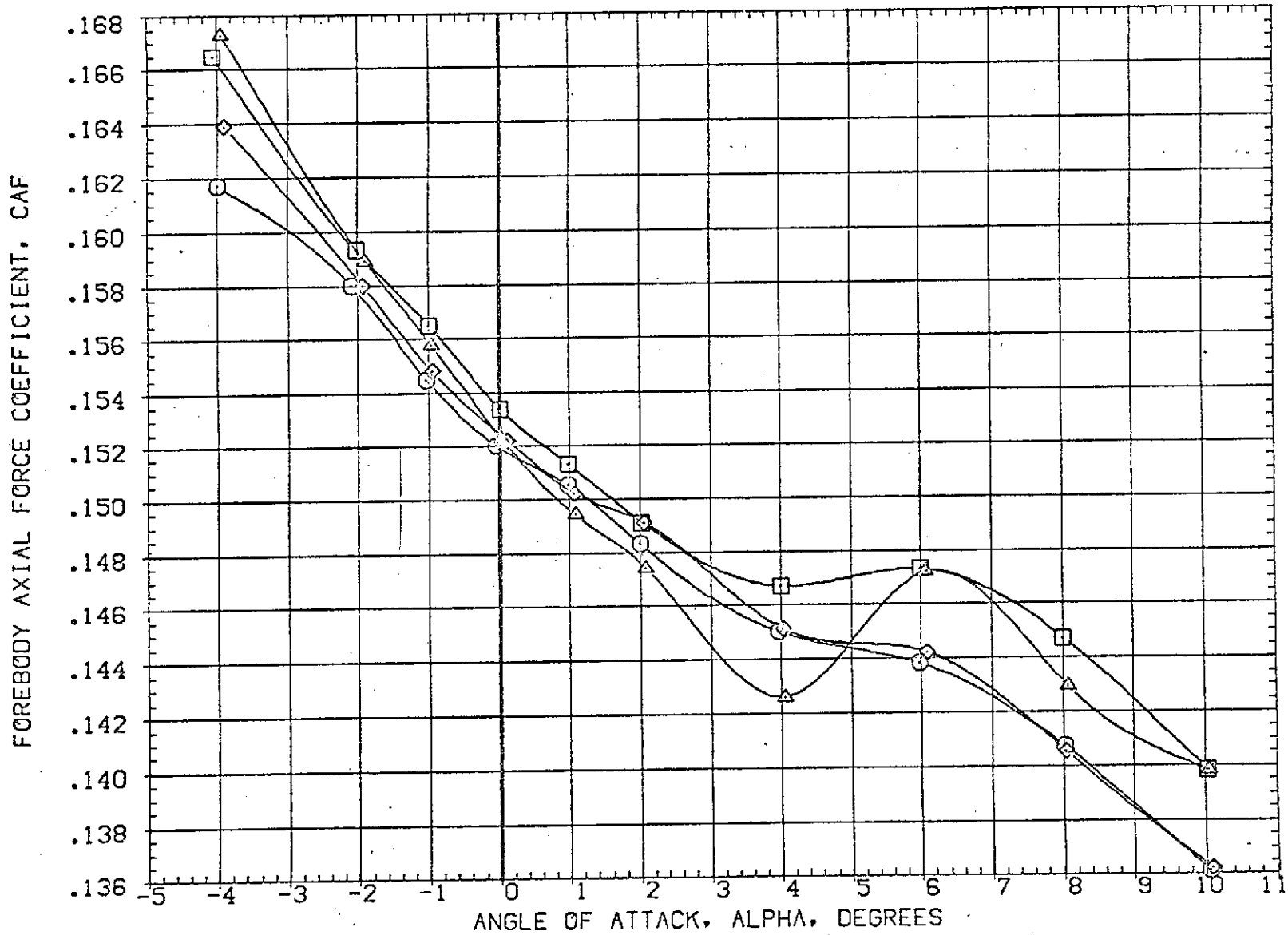

FIG 13 COMPARISON OF CONTROL EFFECTIVENESS WITH GASEOUS AND SOLID SRM PLUMES

(A) MACH = 1.60

DATA SET SYMBOL	CONFIGURATION DESCRIPTION	ELEVON	AILRON	RUDDER	PLUMES	REFERENCE INFORMATION
(EBJ003)	AMES 97-616 1A2 01 TO S1 PC/PT NOM. SRM A/A=8	.000	.000	.000	2.000	SREF 3155.0000 SQ.FT.
(EBJ013)	AMES 97-616 1A2 01 TO S1 PC/PT=NOM. SRM A/A=8	10.000	.000	10.000	2.000	LREF 50.8000 FT.
(RB4536)	AMES 97-616 1A2 01 TO S1 M=1.4 SOLID SRM PLUME	.000	.000	.000	.000	BREF 73.5000 FT.
(RB4539)	AMES 97-616 1A2 01 TO S1 M=1.4 SOLID SRM PLUME	10.000	.000	10.000	.000	XMRP 86.4167 FT.
						YMRP .0000 FT.
						ZMRP 4.0000 FT.
						SCALE .0190

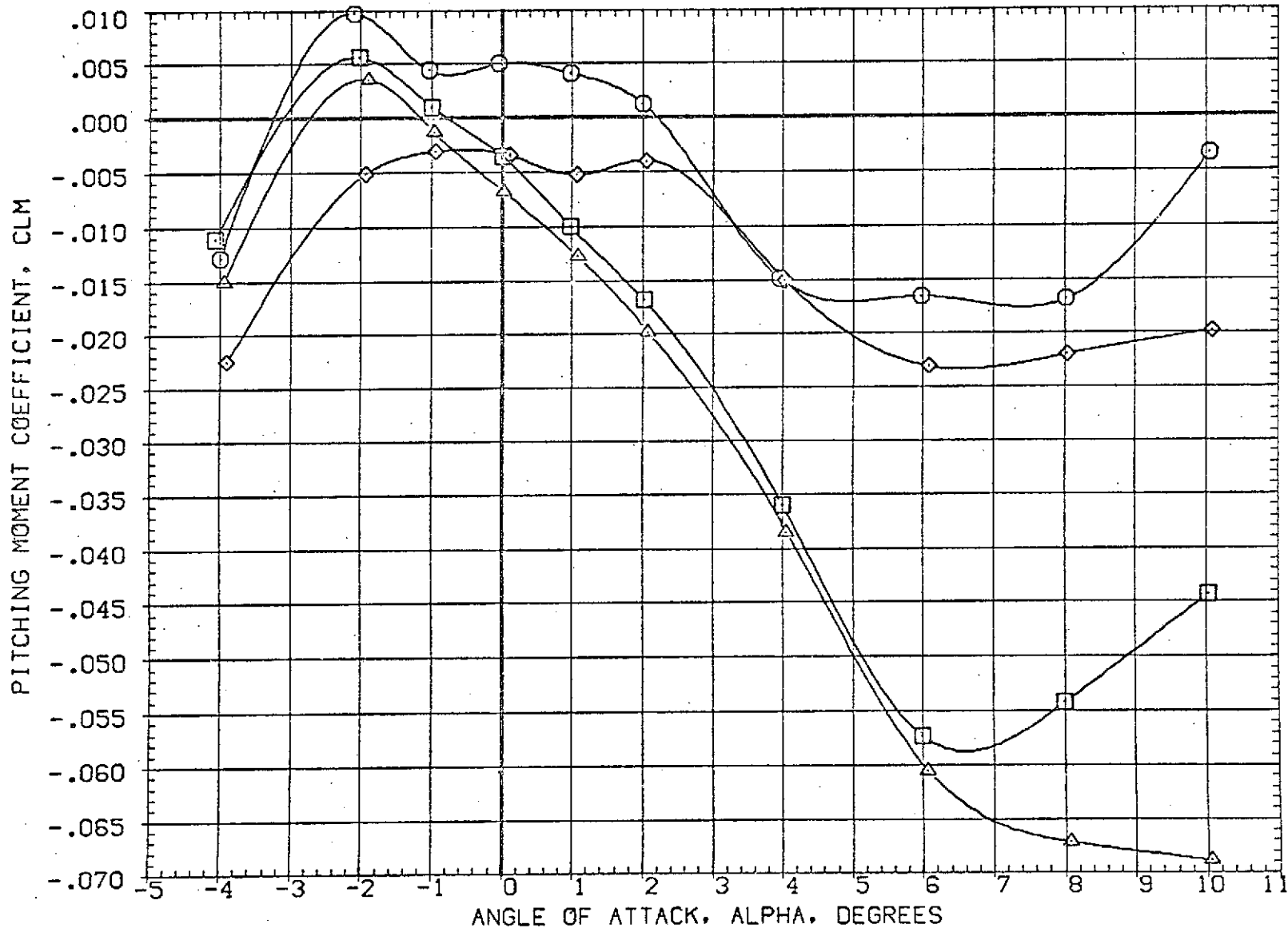

FIG 13 COMPARISON OF CONTROL EFFECTIVENESS WITH GASEOUS AND SOLID SRM PLUMES

(A)MACH = 1.60

DATA SET SYMBOL	CONFIGURATION DESCRIPTION	ELEVON	AILRON	RUDDER	PLUMES	REFERENCE INFORMATION
(EJ003)	AMES 97-616 1A2 01 TO S1 PC/PT-NOM, SRM A/A=8	10.000	.000	.000	2.000	SREF 3155.0000 SQ. FT.
(EJ013)	AMES 97-616 1A2 01 TO S1 PC/PT-NOM, SRM A/A=8	10.000	.000	10.000	2.000	LREF 50.8000 FT.
(R3/S35)	AMES 97-616 1A2 01 TO S1 M=1.4 SOLID SRM PLUME	.000	.000	.000	.000	BREF 73.5000 FT.
(R3/S39)	AMES 97-616 1A2 01 TO S1 M=1.4 SOLID SRM PLUME	10.000	.000	10.000	.000	XMRP 86.4167 FT.
						YMRP .0000 FT.
						ZMRP 4.0000 FT.
						SCALE .0190

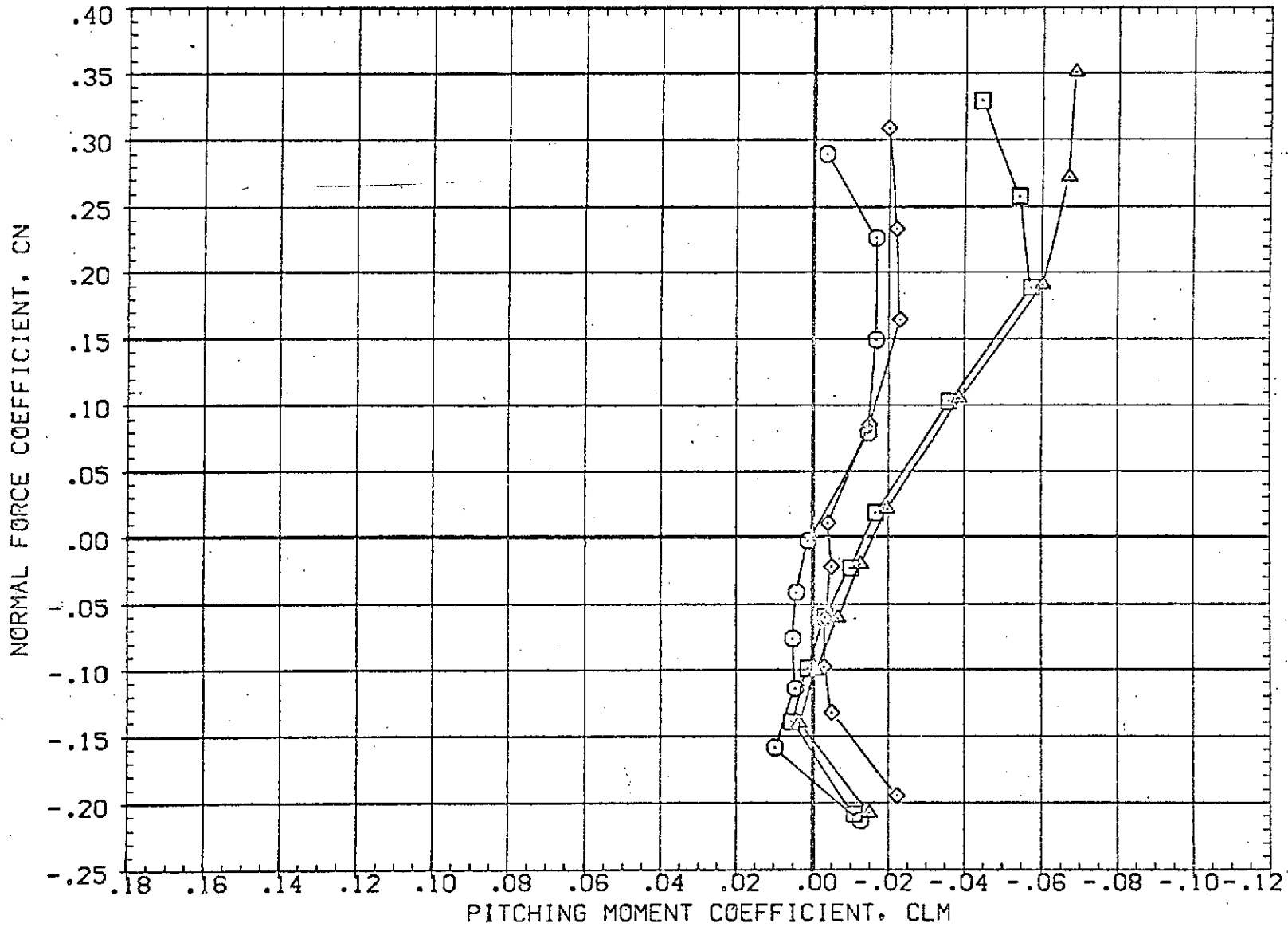

FIG 13 COMPARISON OF CONTROL EFFECTIVENESS WITH GASEOUS AND SOLID SRM PLUMES

(A) MACH = 1.60

DATA SET SYMBOL	CONFIGURATION DESCRIPTION	ELEVON	AILERON	RUDDER	PLUMES	REFERENCE INFORMATION
(EBJ003)	AMES 97-616 1A2 01 TO S1 PC/PT-NGM, SRM A/A=8	.000	.000	.000	2.000	SREF 3155.0000 SQ.FT.
(EBJ013)	AMES 97-616 1A2 01 TO S1 PC/PT-NGM, SRM A/A=8	10.000	.000	10.000	2.000	LREF 50.8000 FT.
(RBJ536)	AMES 97-616 1A2 01 TO S1 M=1.4 SOLID SRM PLUME	.000	.000	.000	.000	BREF 73.5000 FT.
(RBJ539)	AMES 97-616 1A2 01 TO S1 M=1.4 SOLID SRM PLUME	10.000	.000	10.000	.000	XMRP 86.4167 FT. YMRP .0000 FT. ZMRP 4.0000 FT. SCALE .0190

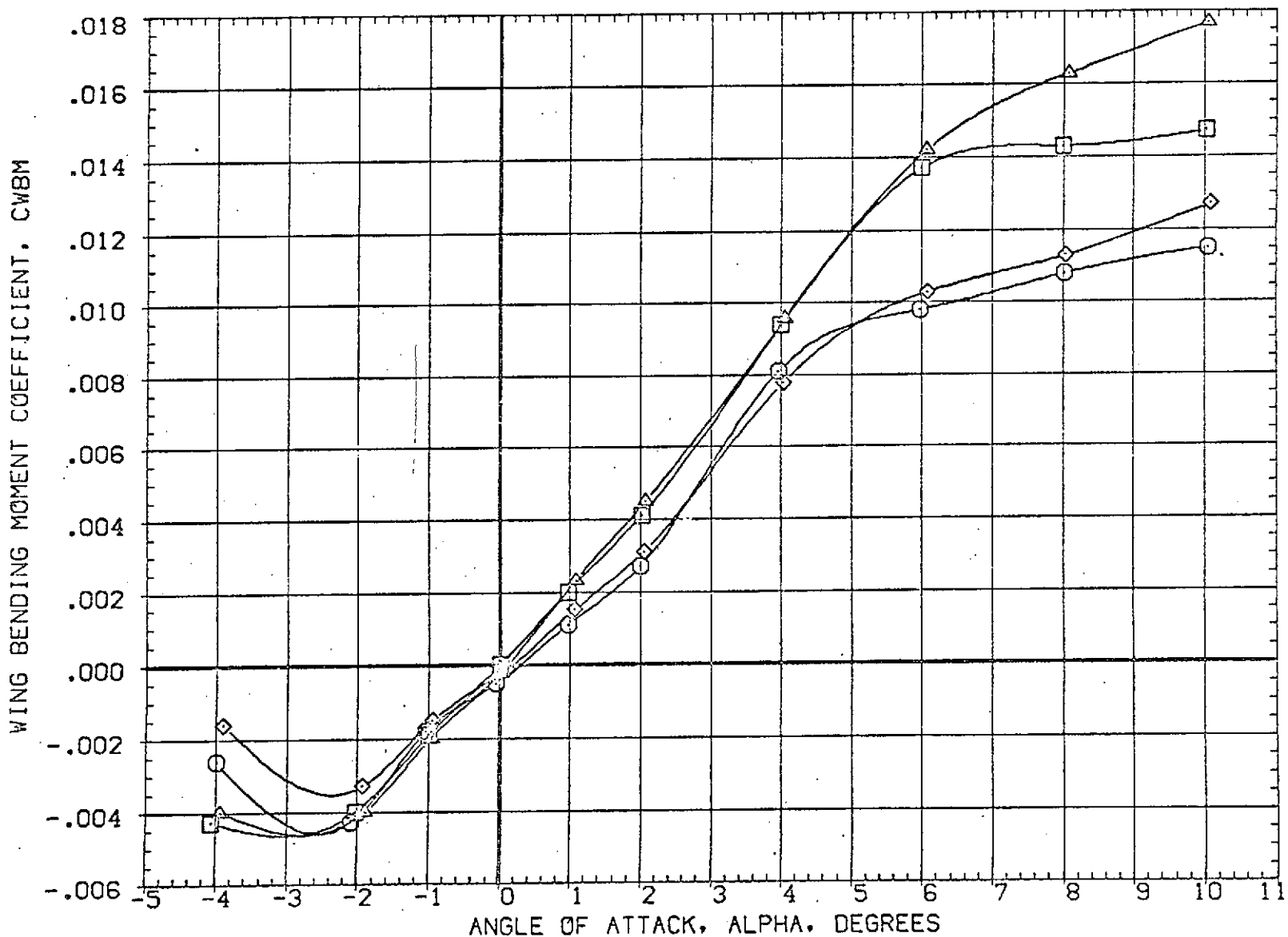

FIG 13 COMPARISON OF CONTROL EFFECTIVENESS WITH GASEOUS AND SOLID SRM PLUMES

(A) MACH = 1.60

DATA SET	SYMBOL	CONFIGURATION DESCRIPTION	ELEVON	AILERON	RUDDER	PLUMES	REFERENCE IN ORIGIN
(RB0004)	□	AMES 97-616 IA2 01 TO S1 PC/PT NOM, SRM A/A=8	.000	.000	.000	2.000	SREF 3155.0000 SQ.FT
(RB014)	○	AMES 97-616 IA2 01 TO S1 PC/PT=NOM, SRM A/A=8	10.000	.000	10.000	2.000	LREF 50.8000 FT.
(RB0538)	×	AMES 97-616 IA2 01 TO S1 M=1.4 SOLID SRM PLUME	.000	.000	.000	.000	BREF 73.5000 FT.
(RB0540)	△	AMES 97-616 IA2 01 TO S1 M=1.4 SOLID SRM PLUME	10.000	.000	10.000	.000	XMRP 86.4167 FT.
							YMRP .0000 FT.
							ZMRP 4.0000 FT.
							SCALE .0190

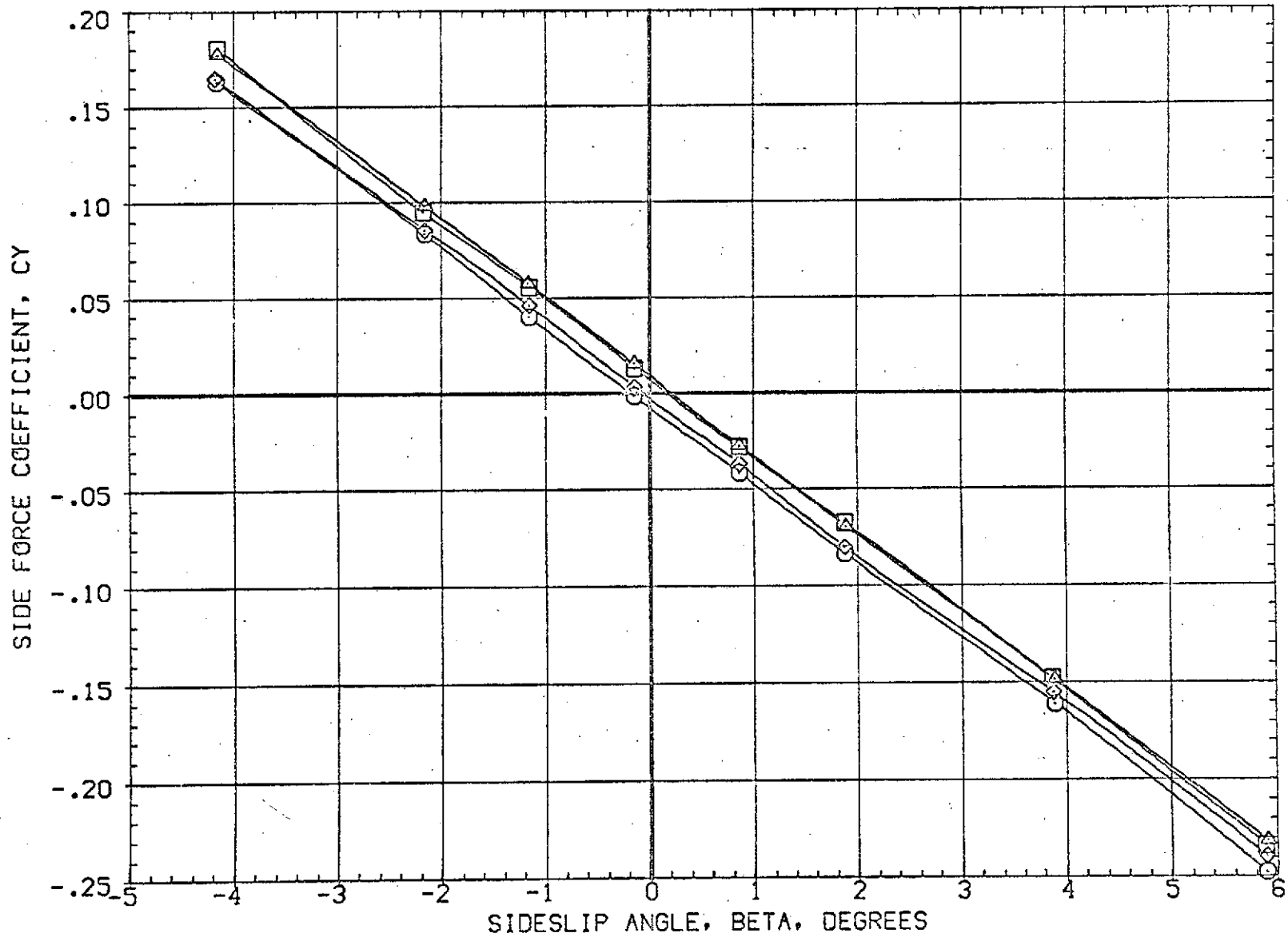

FIG 13 COMPARISON OF CONTROL EFFECTIVENESS WITH GASEOUS AND SOLID SRM PLUMES

(A) MACH = 1.60

DATA SET SYMBOL	CONFIGURATION DESCRIPTION	ELEVON	AILRON	RUDDER	PLUMES	REFERENCE INFORMATION
(EBJ004)	AMES 97-616 1A2 01 TO S1 PC/PT NOM. SRM A/A=8	.000	.000	.000	2.000	SREF 3155.0000 SQ.FT
(EBJ014)	AMES 97-616 1A2 01 TO S1 PC/PT=NOM. SRM A/A=8	10.000	.000	10.000	2.000	LREF 50.8000 FT.
(RBJ538)	AMES 97-616 1A2 01 TO S1 M=1.4 SOLID SRM PLUME	.000	.000	.000	.000	BREF 73.5000 FT.
(RBJ540)	AMES 97-616 1A2 01 TO S1 M=1.4 SOLID SRM PLUME	10.000	.000	10.000	.000	XMRP 86.4167 FT.
						YMRP .0000 FT.
						ZMRP 4.0000 FT.
						SCALE .0190

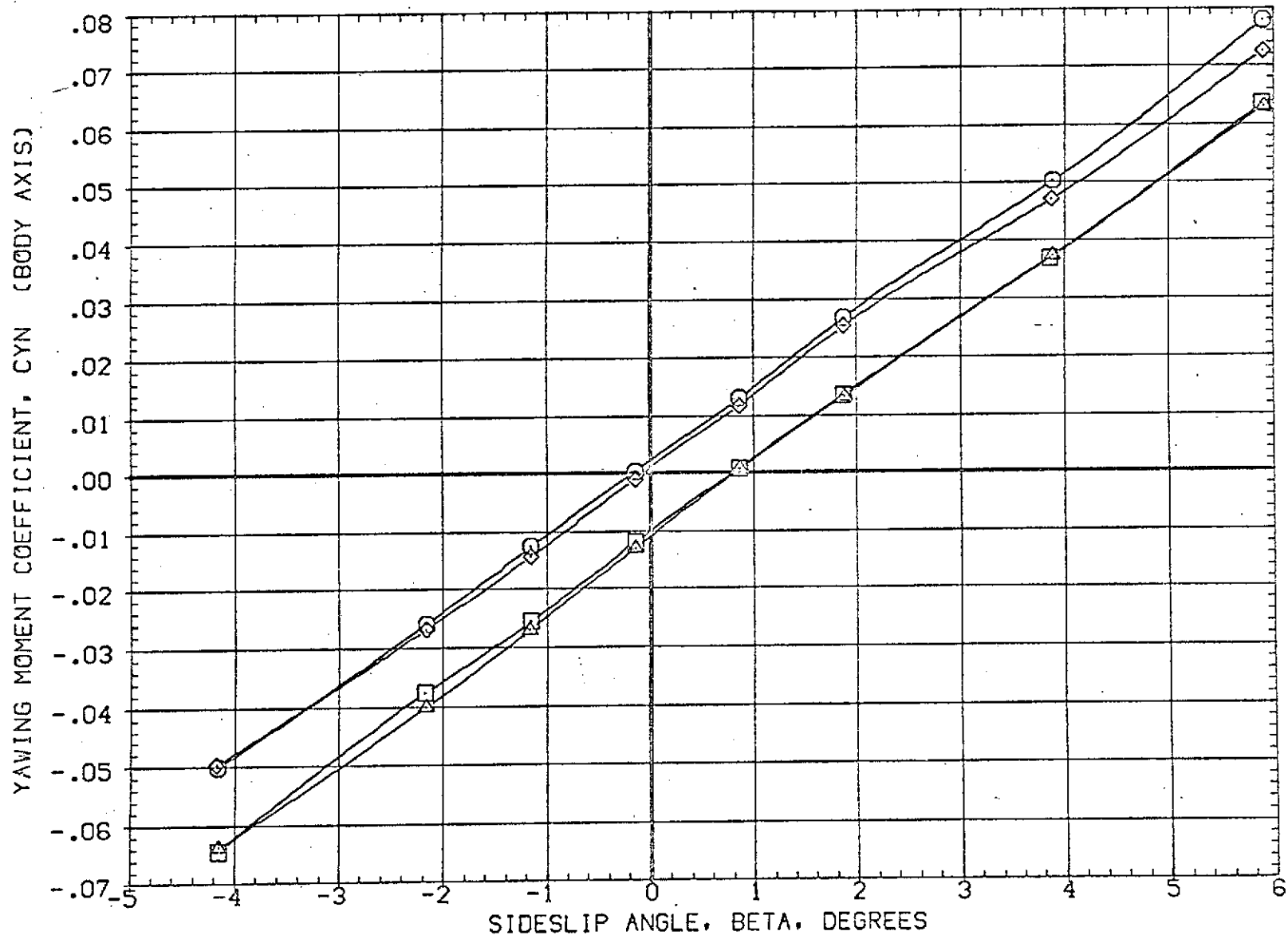

FIG 13 COMPARISON OF CONTROL EFFECTIVENESS WITH GASEOUS AND SOLID SRM PLUMES

(A) MACH = 1.60

DATA SET SYMBOL	CONFIGURATION DESCRIPTION	ELEVON	AILERON	RUDDER	PLUMES	REFERENCE INFORMATION		
(EBJ004)	AMES 97-616 IA2 01 TO S1 PC/PT NOM, SRM A/A=8	.000	.000	.000	2.000	SREF	3155.0000	SQ.FT.
(EBJ014)	AMES 97-616 IA2 01 TO S1 PC/PT=NOM, SRM A/A=8	10.000	.000	10.000	2.000	LREF	50.8000	FT.
(RBJ538)	AMES 97-616 IA2 01 TO S1 M=1.4 SOLID SRM PLUME	.000	.000	.000	.000	BREF	73.5000	FT.
(RBJ540)	AMES 97-616 IA2 01 TO S1 M=1.4 SOLID SRM PLUME	10.000	.000	10.000	.000	XMRP	86.4167	FT.
						YMRP	.0000	FT.
						ZMRP	4.0000	FT.
						SCALE	.0190	

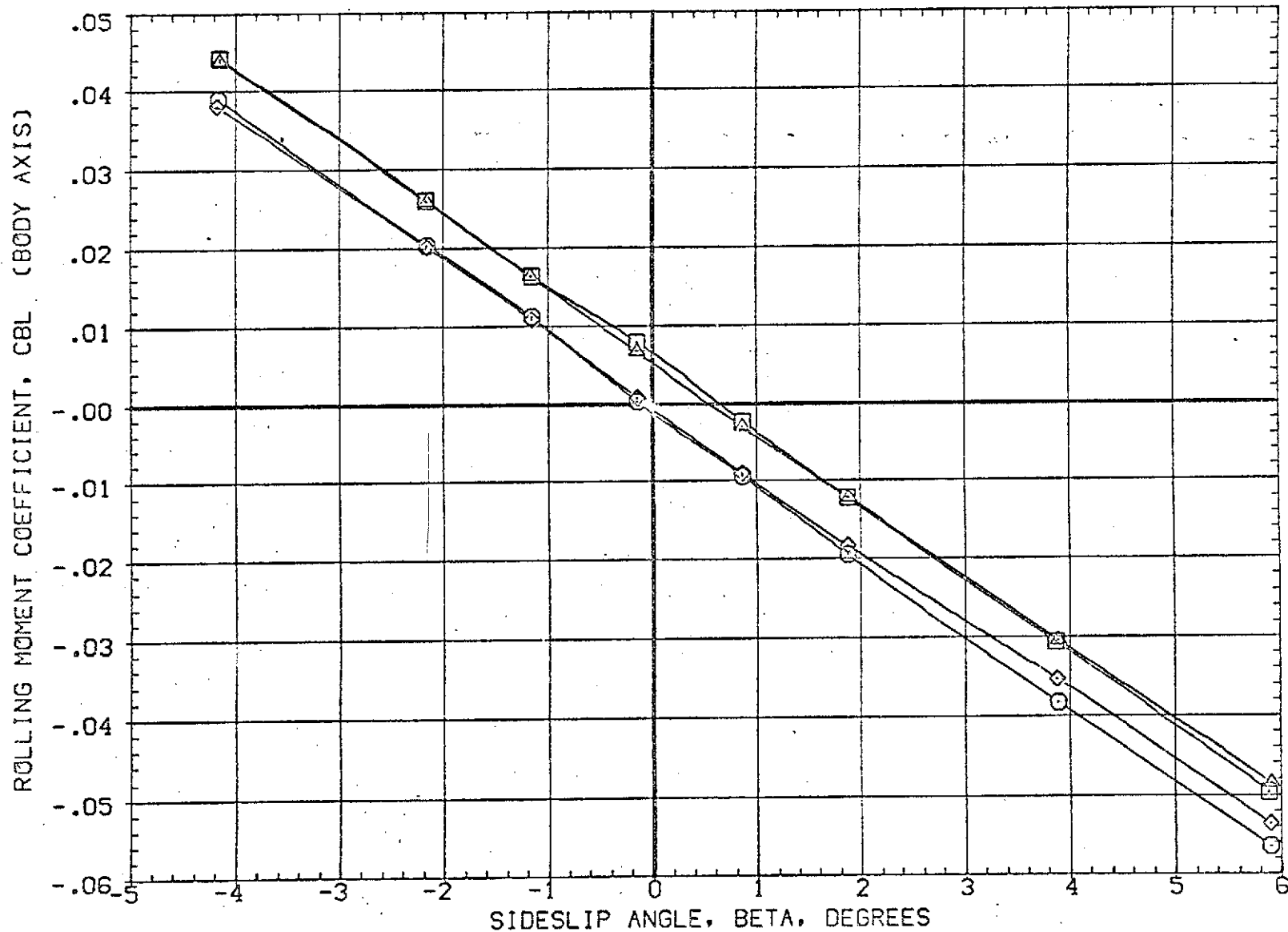

FIG 13 COMPARISON OF CONTROL EFFECTIVENESS WITH GASEOUS AND SOLID SRM PLUMES

(A) MACH = 1.60

DATA SET SYMBOL	CONFIGURATION DESCRIPTION	ELEVON	AILRON	RUDDER	PLUMES	REFERENCE INFORMATION
(EBJ004)	AMES 97-616 IA2 01 TO SI PC/PT NOM, SRM A/A=8	.000	.000	.000	2.000	SREF 3155.0000 SQ.FT
(EBJ014)	AMES 97-616 IA2 01 TO SI PC/PT=NOM, SRM A/A=8	10.000	.000	10.000	2.000	LREF 50.8000 FT.
(RBJ538)	AMES 97-616 IA2 01 TO SI M=1.4 SOLID SRM PLUME	.000	.000	.000	.000	BREF 73.5000 FT.
(RBJ540)	AMES 97-616 IA2 01 TO SI M=1.4 SOLID SRM PLUME	10.000	.000	10.000	.000	XMRP 86.4167 FT.
						YMRP .0000 FT.
						ZMRP 4.0000 FT.
						SCALE .0190

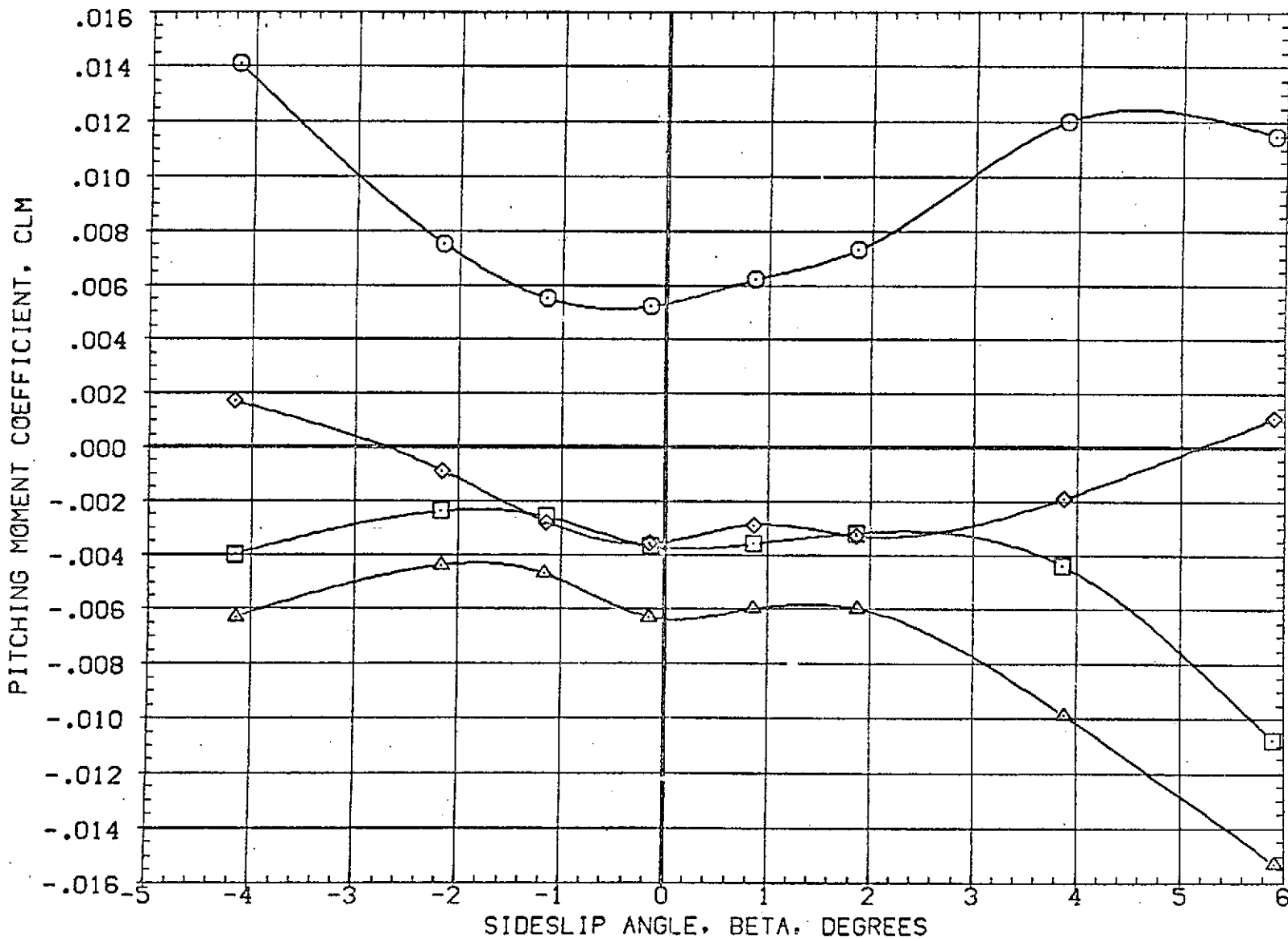

FIG 13 COMPARISON OF CONTROL EFFECTIVENESS WITH GASEOUS AND SOLID SRM PLUMES

(A) MACH = 1.60

DATA SET SYMBOL	CONFIGURATION DESCRIPTION	ELEVON	AILRON	RUDDER	PLUMES	REFERENCE INFORMATION		
(EBJ004)	AMES 97-616 1A2 01 TO S1 PC/PT NOM. SRM A/A=8	.000	.000	.000	2.000	SREF	3155.0000	59. FT.
(EBJ014)	AMES 97-616 1A2 01 TO S1 PC/PT=NCM. SRM A/A=8	10.000	.000	10.000	2.000	LREF	50.8000	FT.
(RBJ539)	AMES 97-616 1A2 01 TO S1 M=1.4 SOLID SRM PLUME	.000	.000	.000	.000	BREF	73.5000	FT.
(RBJ540)	AMES 97-616 1A2 01 TO S1 M=1.4 SOLID SRM PLUME	10.000	.000	10.000	.000	XMRP	85.4167	FT.
						YMRP	.0000	FT.
						ZMRP	4.0000	FT.
						SCALE	.0190	

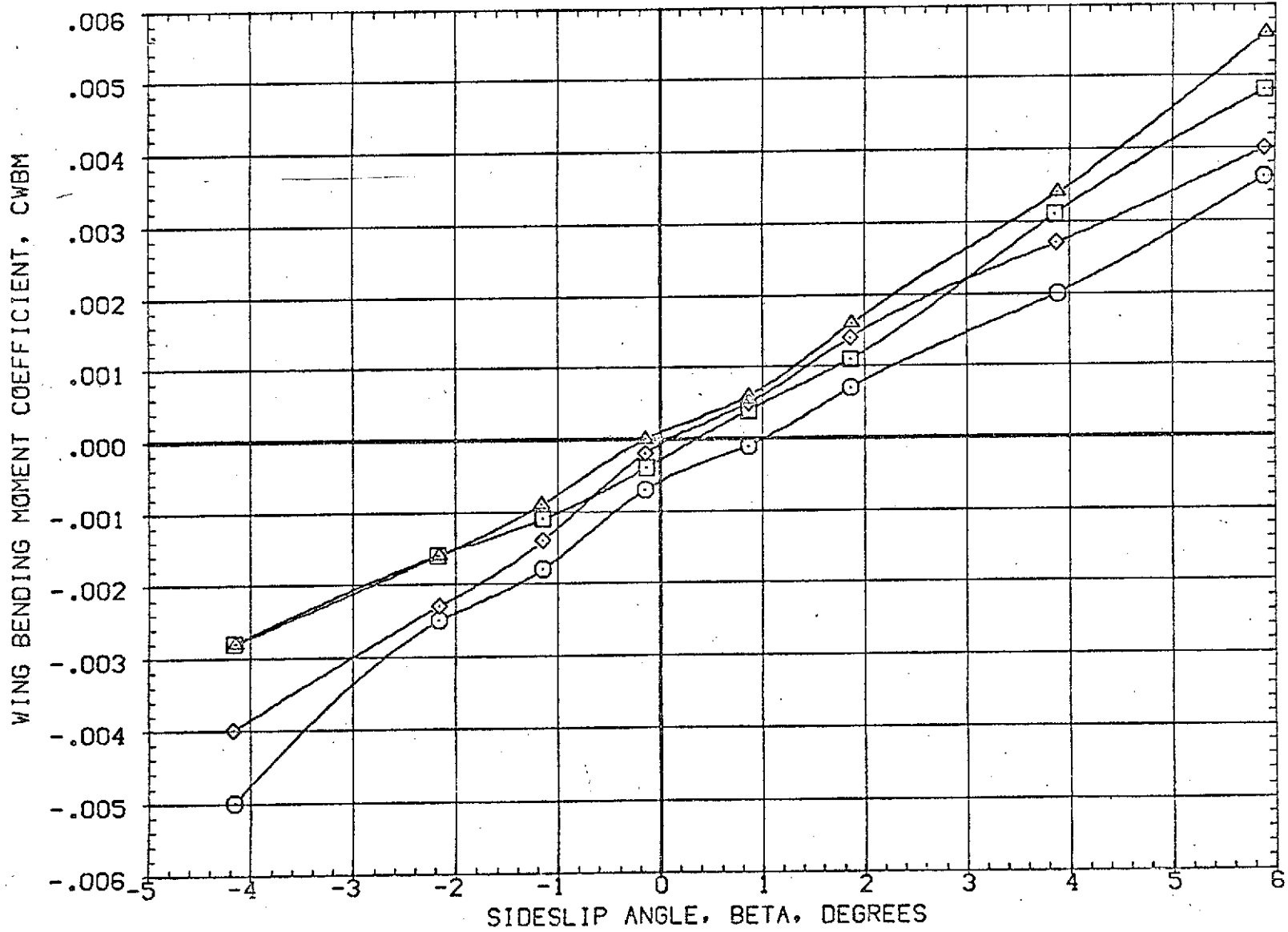

FIG 13 COMPARISON OF CONTROL EFFECTIVENESS WITH GASEOUS AND SOLID SRM PLUMES
 (A) MACH = 1.60

DATA SET SYMBOL	CONFIGURATION DESCRIPTION	ELEVON	AILRON	RUDDER	PLUMES	REFERENCE INFORMATION
{EBJ501}	AMES 97-616 IA2 01 TO S1 NO PLUMES	.000	.000	.000	.000	SREF 3155.0000 SQ.FT.
{EBJ001}	AMES 97-616 IA2 01 TO S1 PC/PT NOM.SRM A/A-8	.000	.000	.000	5.000	LREF 50.8000 FT.
{RBJ527}	AMES 97-616 IA2 01 TO S1 CMS NO PLUMES	.000	.000	.000	.000	BREF 73.5000 FT.
{RBJ027}	AMES 97-616 IA2 01 TO S1 CMS,PC/PT=NOM.SRM A/A-8	.000	.000	.000	5.000	XMRP 86.4167 FT.
						YMRP .0000 FT.
						ZMRP 4.0000 FT.
						SCALE .0190

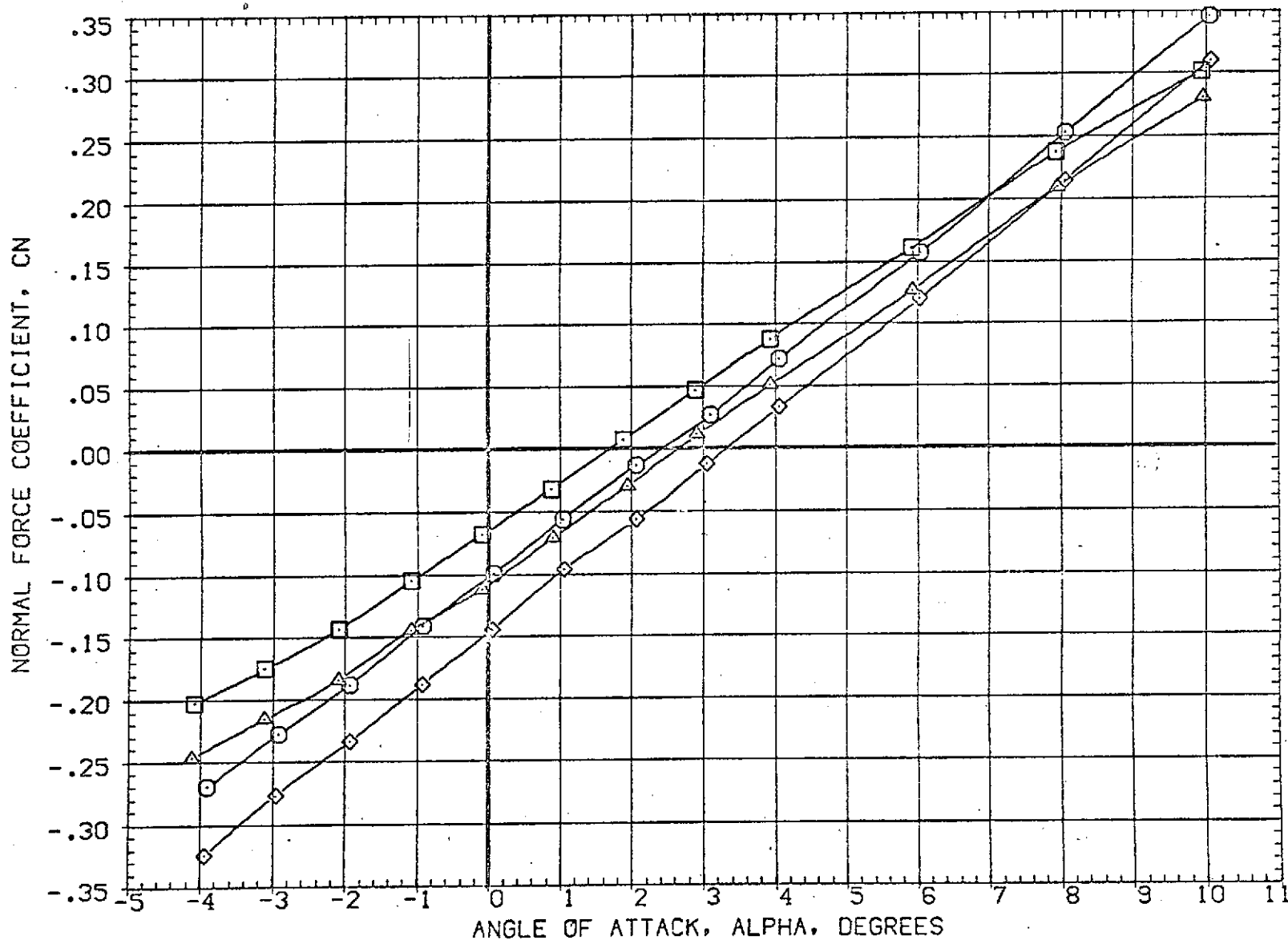

FIG 14 PLUME EFFECTS WITH AND WITHOUT CMS

(A)MACH = 1.60

DATA SET SYMBOL	CONFIGURATION DESCRIPTION	ELEVON	AILRON	RUDDER	PLUMES	REFERENCE INFORMATION
(EBJ501)	AMES 97-616 [A2 01 TO S1] NO PLUMES	.000	.000	.000	.000	SREF 3155.0000 SQ.FT.
(EBJ001)	AMES 97-616 [A2 01 TO S1] PC/PT NOM, SRM A/A=B	.000	.000	.000	5.000	LREF 50.8000 FT.
(RBJ527)	AMES 97-616 [A2 01 TO S1] OMS NO PLUMES	.000	.000	.000	.000	BREF 73.5000 FT.
(RBJ027)	AMES 97-616 [A2 01 TO S1] OMS, PC/PT=NOM, SRM A/A=B	.000	.000	.000	5.000	XMRP 86.4167 FT.
						YMRP .0000 FT.
						ZMRP 4.0000 FT.
						SCALE .0190

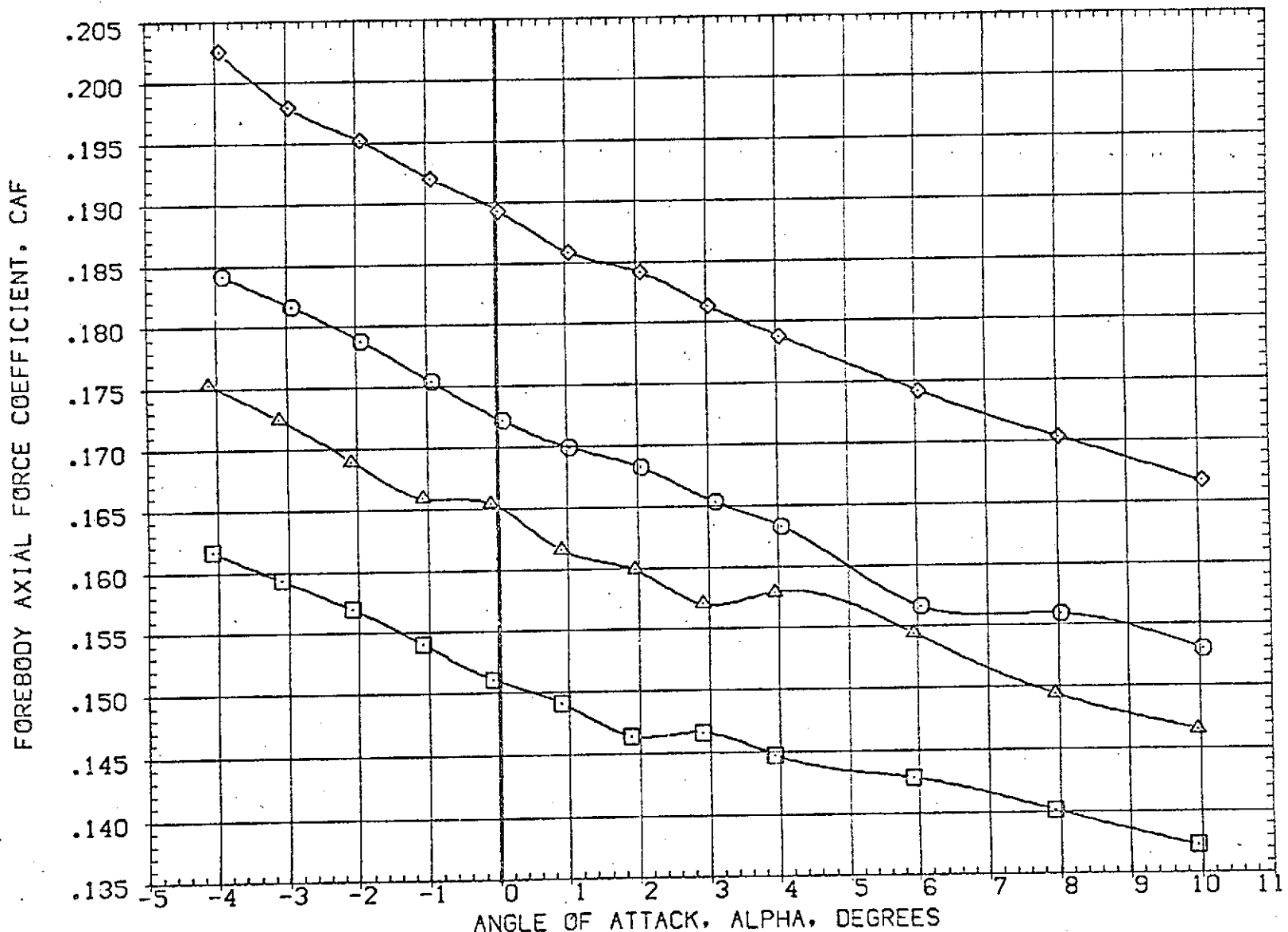

FIG 14 PLUME EFFECTS WITH AND WITHOUT OMS

(A)MACH = 1.60

DATA SET SYMBOL	CONFIGURATION DESCRIPTION	ELEVON	AILRON	RUDDER	PLUMES	REFERENCE INFORMATION		
(EBJS01)	AMES 97-616 IA2 01 TO S1 NO PLUMES	.000	.000	.000	.000	SREF	3155.0000	SQ.FT.
(EBJ001)	AMES 97-616 IA2 01 TO S1 PC/PT NOM.SRM A/A=8	.000	.000	.000	5.000	LREF	50.8000	FT.
(RBJS27)	AMES 97-616 IA2 01 TO S1 OMS NO PLUMES	.000	.000	.000	.000	BREF	73.5000	FT.
(RBJS27)	AMES 97-616 IA2 01 TO S1 OMS,PC/PT=NOM.SRM A/A=8	.000	.000	.000	5.000	XMRP	85.4157	FT.
						YMRP	.0000	FT.
						ZMRP	4.0000	FT.
						SCALE	.0190	

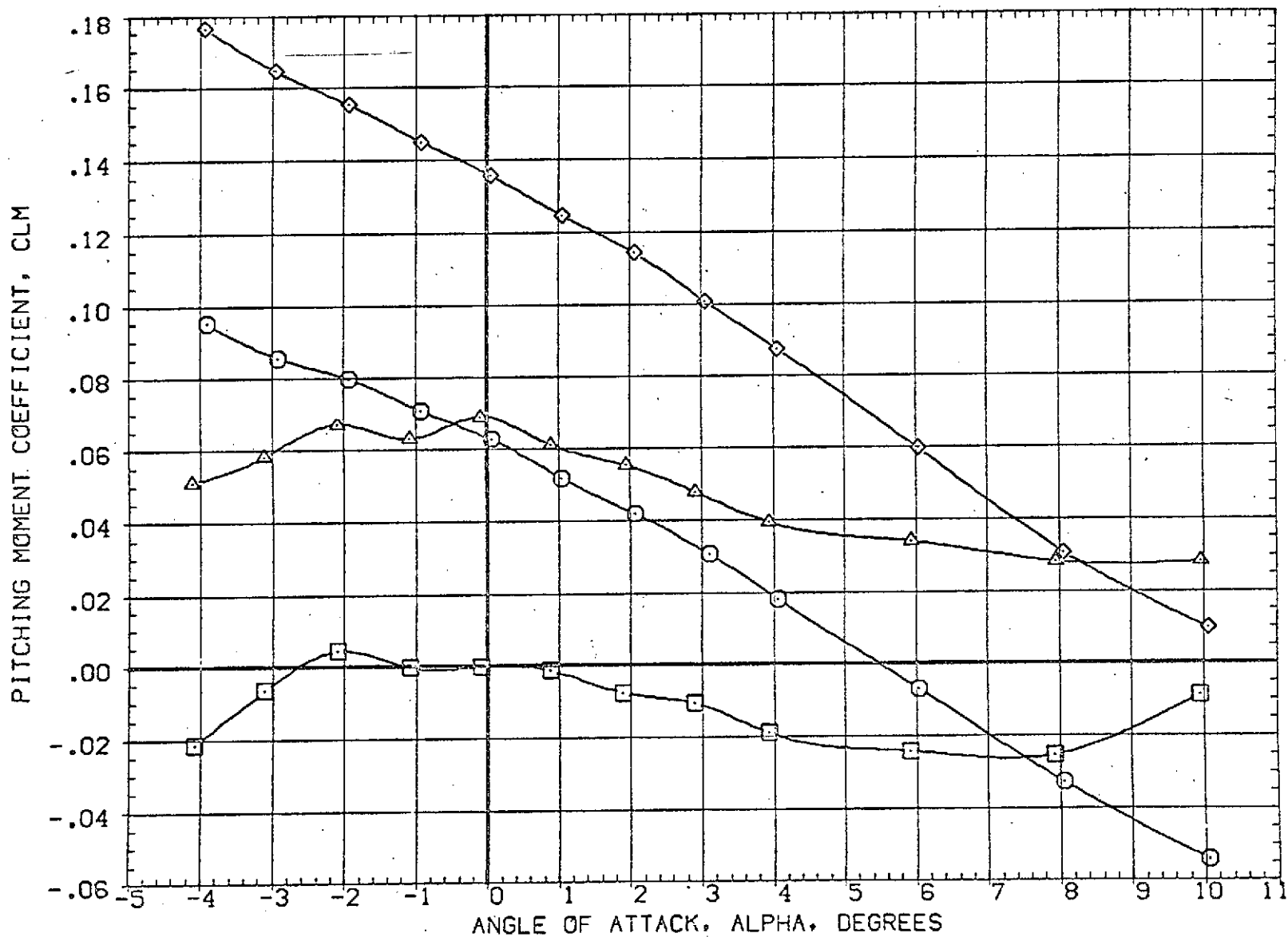

FIG 14 PLUME EFFECTS WITH AND WITHOUT OMS

(A)MACH = 1.60

DATA SET SYMBOL	CONFIGURATION DESCRIPTION	ELEVON	AILERON	RUDDER	PLUMES	REFERENCE INFORMATION	
(RBJ501)	AMES 97-616 1A2 01 TO S1 NO PLUMES	.000	.000	.000	.000	SREF	3155.0000 SQ.FT.
(RBJ001)	AMES 97-616 1A2 01 TO S1 PC/PT NOM,SRM A/A=8	.000	.000	.000	5.000	LREF	50.8000 FT.
(RBJ527)	AMES 97-616 1A2 01 TO S1 OMS NO PLUMES	.000	.000	.000	.000	BREF	73.5000 FT.
(RBJ027)	AMES 97-616 1A2 01 TO S1 OMS,PC/PT=NOM,SRM A/A=8	.000	.000	.000	5.000	XMRP	86.4167 FT.
						YMRP	.0000 FT.
						ZMRP	4.0000 FT.
						SCALE	.0150

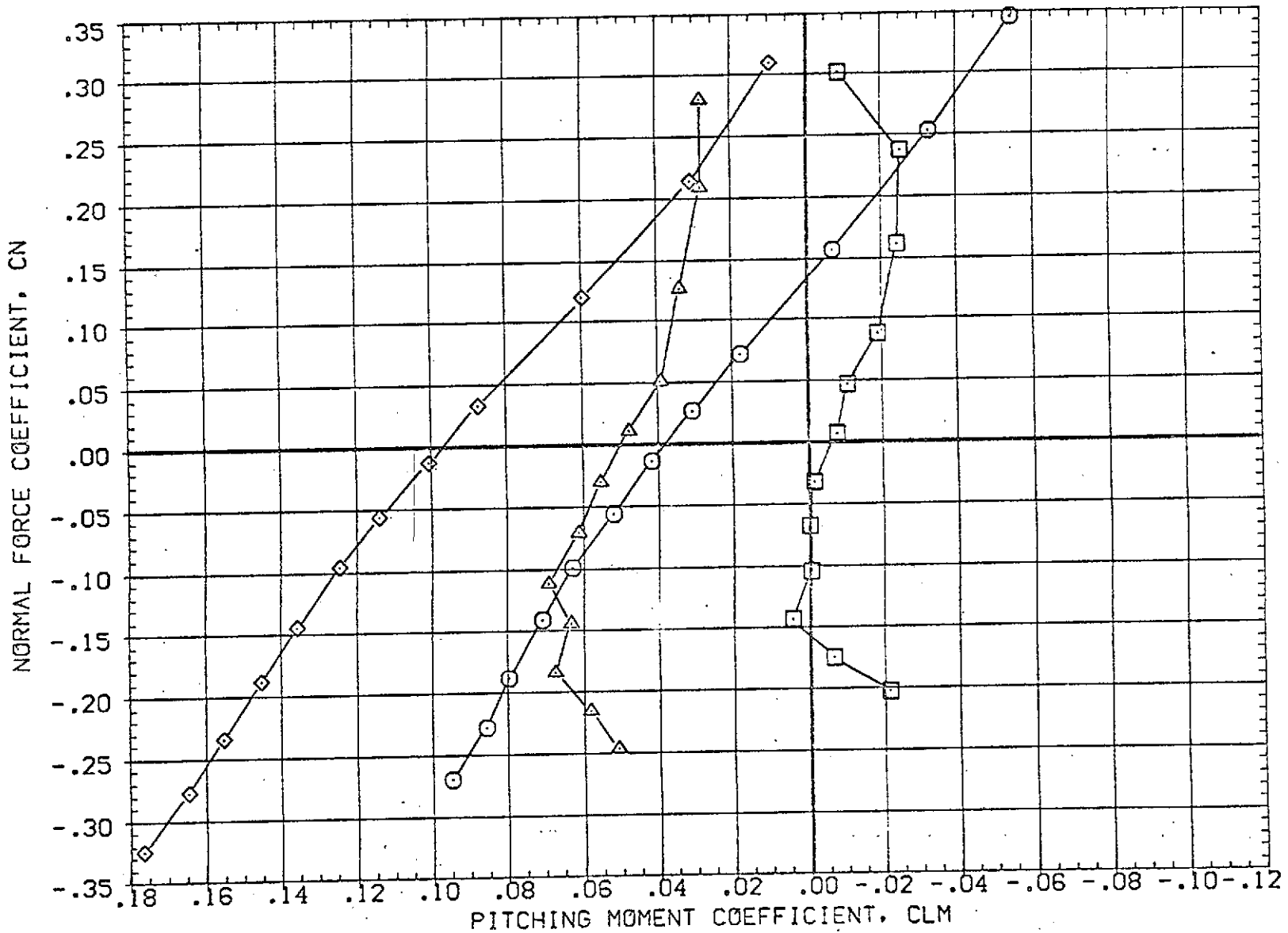

FIG 14 PLUME EFFECTS WITH AND WITHOUT OMS
 (A) MACH = 1.60

DATA SET SYMBOL	CONFIGURATION DESCRIPTION	ELEVON	AILERON	RUDDER	PLUMES	REFERENCE INFORMATION
(EBJ501)	AMES 97-616 1A2 01 TO S1 NO PLUMES	.000	.000	.000	.000	SREF 3155.0000 SQ.FT.
(EBJ001)	AMES 97-616 1A2 01 TO S1 PC/PT NOM, SRM A/A=8	.000	.000	.000	5.000	LREF 50.8000 FT.
(RBJ527)	AMES 97-616 1A2 01 TO S1 OMS NO PLUMES	.000	.000	.000	.000	BREF 73.5000 FT.
(RBJ027)	AMES 97-616 1A2 01 TO S1 OMS, PC/PT=NOM, SRM A/A=8	.000	.000	.000	5.000	XMRP 86.4167 FT.
						YMRP .0000 FT.
						ZMRP 4.0000 FT.
						SCALE .0190

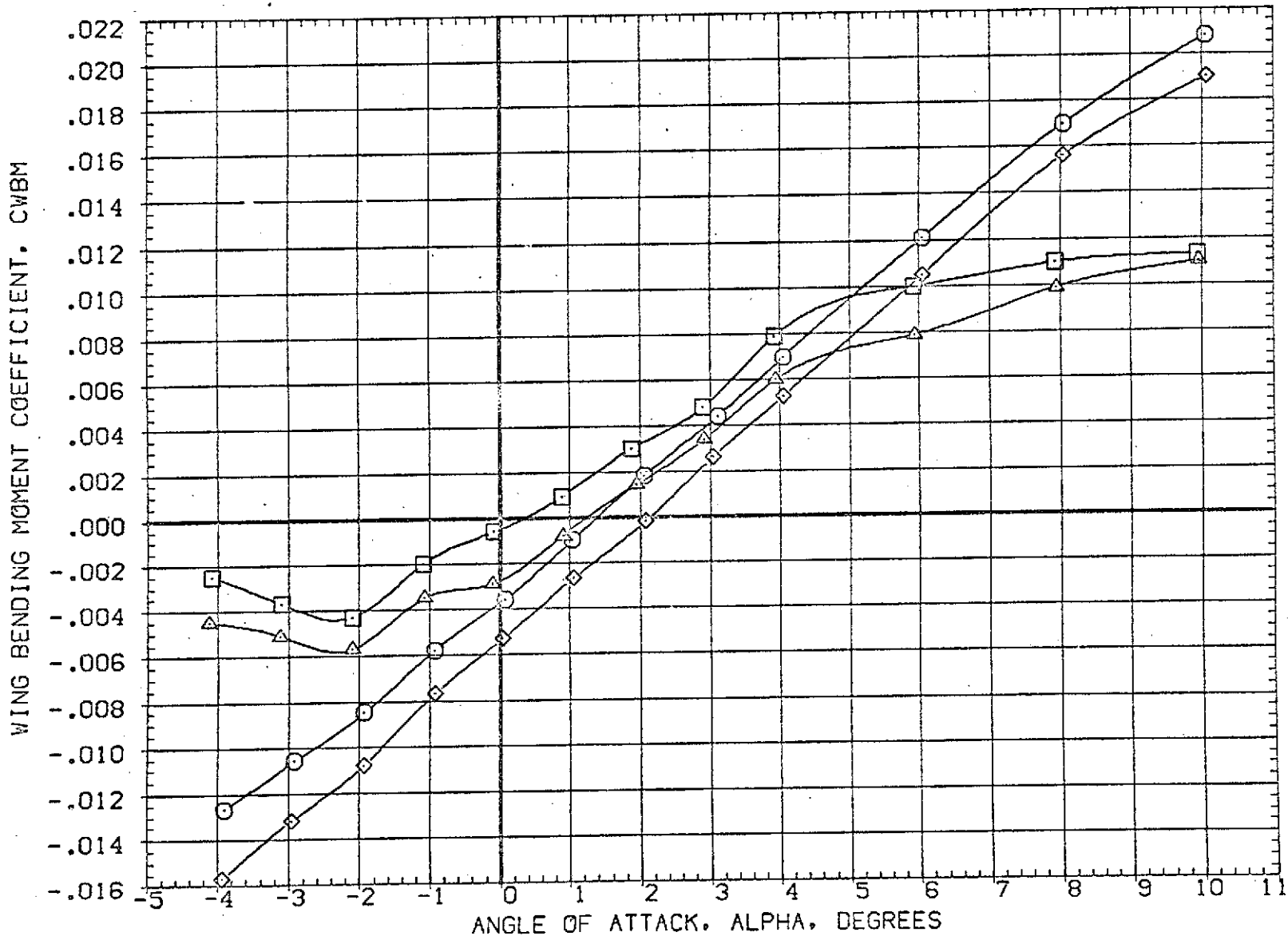

FIG 14 PLUME EFFECTS WITH AND WITHOUT OMS
 (A)MACH = 1.60

DATA SET SYMBOL	CONFIGURATION DESCRIPTION	ELEVON	AILRON	RUDDER	PLUMES	REFERENCE INFORMATION
(EBJS02)	AMES 97-616 IA2 01 TO S1 NO-PLUMES	.000	.000	.000	.000	SREF 3155.0000 SQ.FT.
(YBJ002)	AMES 97-616 IA2 01 TO S1 PC/PT NCM,SRM A/A=8	.000	.000	.000	5.000	LREF 50.8000 FT.
(RBJ029)	AMES 97-616 IA2 01 TO S1 OMS NO PLUMES	.000	.000	.000	.000	BREF 73.5000 FT.
(YBJ029)	AMES 97-616 IA2 01 TO S1 OMS,PC/PT=NCM,SRM A/A=8	.000	.000	.000	5.000	XMRP 86.4167 FT.
						YMRP .0000 FT.
						ZMRP 4.0000 FT.
						SCALE .0190

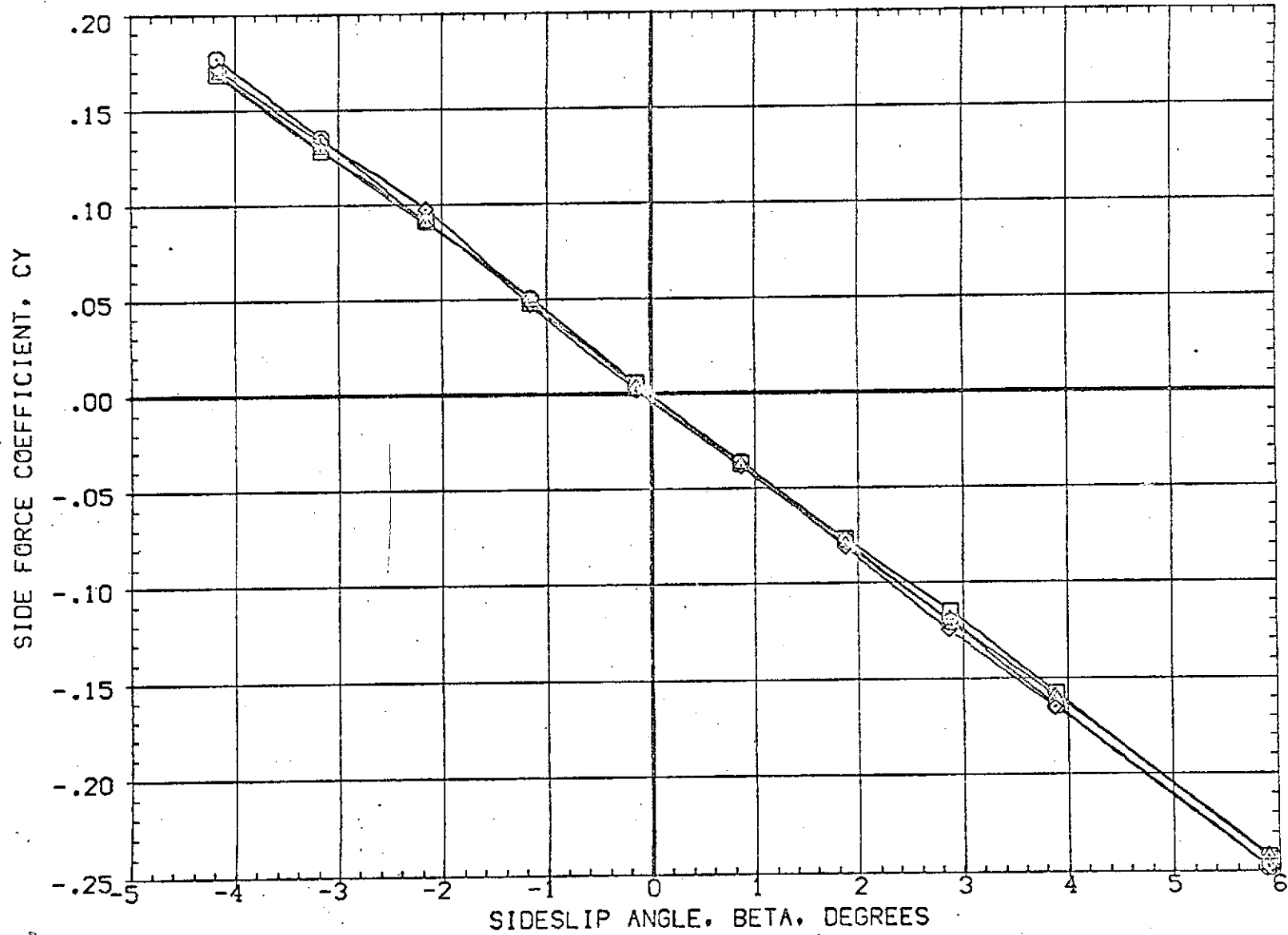

FIG 14 PLUME EFFECTS WITH AND WITHOUT OMS

(A)MACH = 1.60

DATA SET SYMBOL	CONFIGURATION DESCRIPTION	ELEVON	AILERON	RUDDER	PLUMES	REFERENCE INFORMATION
(EBJ502)	AMES 97-616 1A2 01 TO S1 NO PLUMES	.000	.000	.000	.000	SREF 3155.0000 SQ.FT.
(WBJ002)	AMES 97-616 1A2 01 TO S1 PC/PT NOM, SRM A/A=B	.000	.000	.000	5.000	LREF 50.6000 FT.
(RBJ528)	AMES 97-616 1A2 01 TO S1 OMS NO PLUMES	.000	.000	.000	.000	BREF 73.5000 FT.
(WBJ029)	AMES 97-616 1A2 01 TO S1 OMS, PC/PT=NOM, SRM A/A=B	.000	.000	.000	5.000	XMRP 86.4167 FT.
						YMRP .0000 FT.
						ZMRP 4.0000 FT.
						SCALE .0190

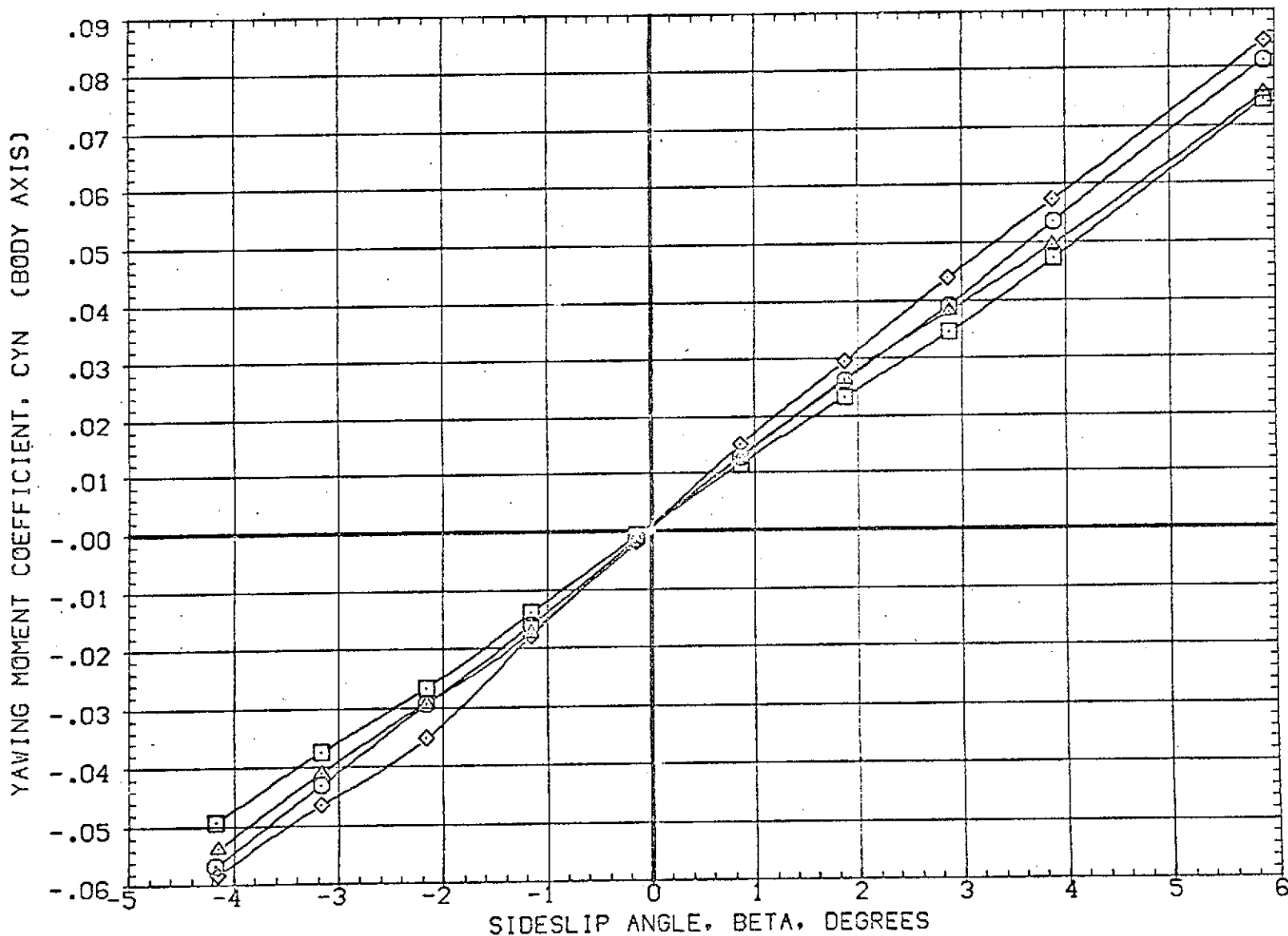

FIG 14 PLUME EFFECTS WITH AND WITHOUT OMS

(A)MACH = 1.60

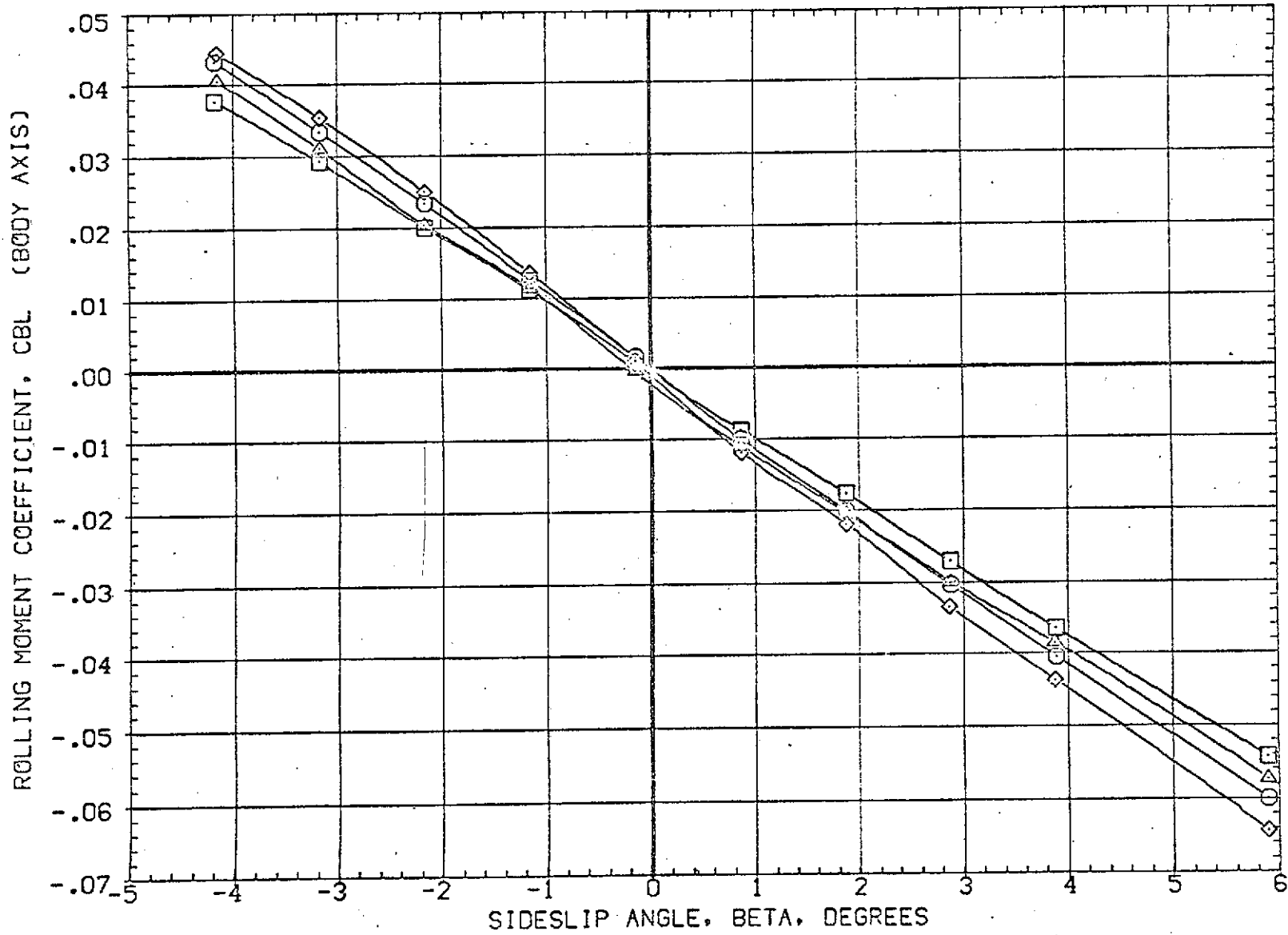

FIG 14 PLUME EFFECTS WITH AND WITHOUT GMS

(A)MACH = 1.60

DATA SET SYMBOL	CONFIGURATION DESCRIPTION	ELEVON	AILRON	RUDDER	PLUMES	REFERENCE INFORMATION
(EBJ502)	AMES 97-616 1A2 01 TO S1 NO PLUMES	.000	.000	.000	.000	SREF 3155.0000 SQ.FT.
(VBJ002)	AMES 97-616 1A2 01 TO S1 PC/PT NOM, SRM A/A=8	.000	.000	.000	5.000	LREF 50.8000 FT.
(RBJS29)	AMES 97-616 1A2 01 TO S1 OMS NO PLUMES	.000	.000	.000	.000	BREF 73.5000 FT.
(VBJS29)	AMES 97-616 1A2 01 TO S1 OMS, PC/PT=NOM, SRM A/A=8	.000	.000	.000	5.000	XMRP 86.4167 FT.
						YMRP .0000 FT.
						ZMRP 4.0000 FT.
						SCALE .0190

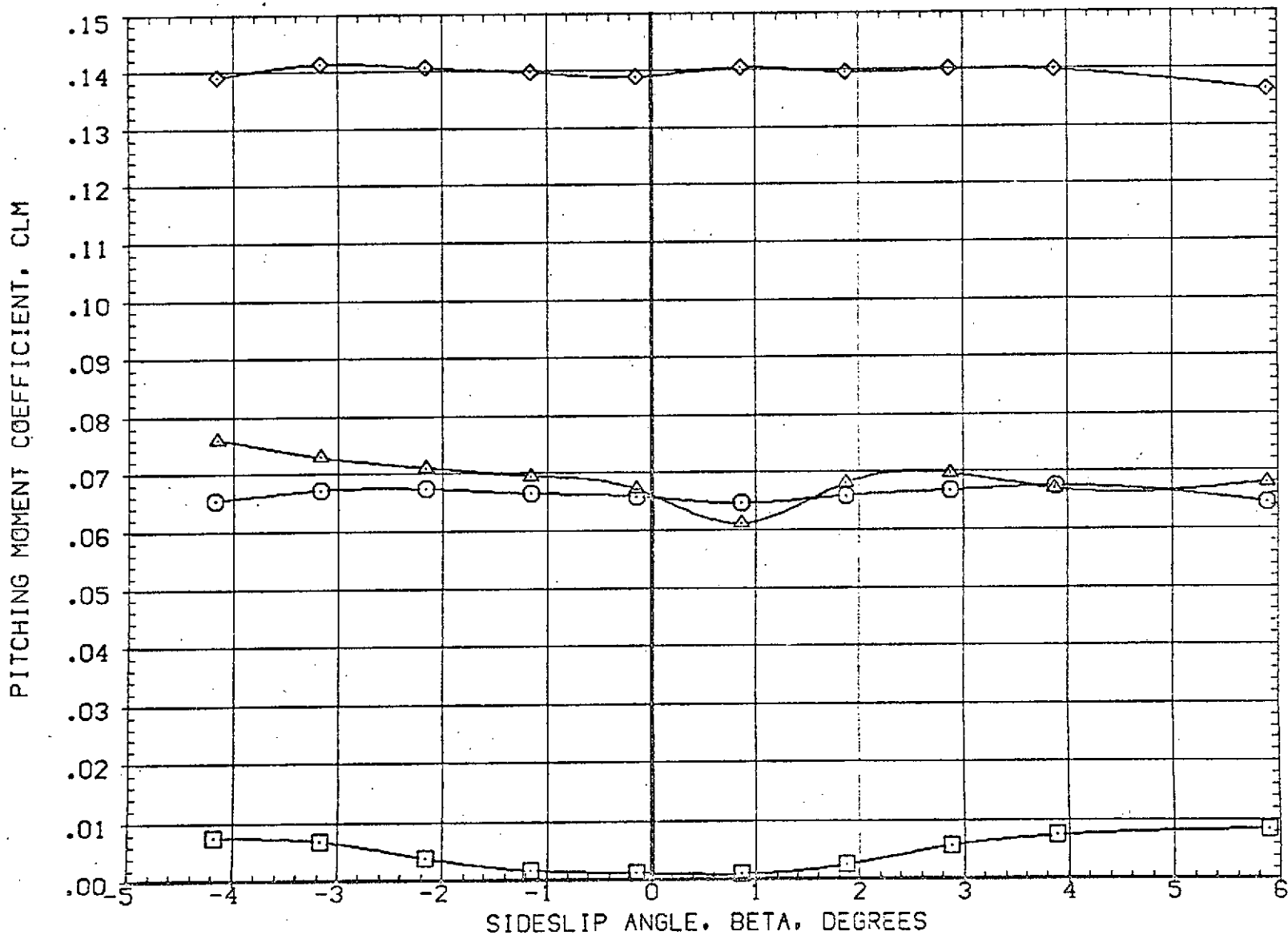

FIG 14 PLUME EFFECTS WITH AND WITHOUT OMS

(A)MACH = 1.60

DATA SET SYMBOL	CONFIGURATION DESCRIPTION	ELEVON	AILERON	RUDDER	PLUMES	REFERENCE INFORMATION		
(EBJ502)	AMES 97-616 1A2 01 TO S1 NO PLUMES	.000	.000	.000	.000	SREF	3155.0000	50.FT.
(VBJ002)	AMES 97-616 1A2 01 TO S1 PC/PT NOM.SRM A/A=8	.000	.000	.000	5.000	LREF	50.8000	FT.
(RBJ529)	AMES 97-616 1A2 01 TO S1 CMS NO PLUMES	.000	.000	.000	.000	BREF	73.5000	FT.
(VBJ029)	AMES 97-616 1A2 01 TO S1 CMS,PC/PT=NOM.SRM A/A=8	.000	.000	.000	5.000	XMRP	88.4167	FT.
						YMRP	.0000	FT.
						ZMRP	4.0000	FT.
						SCALE	.0190	

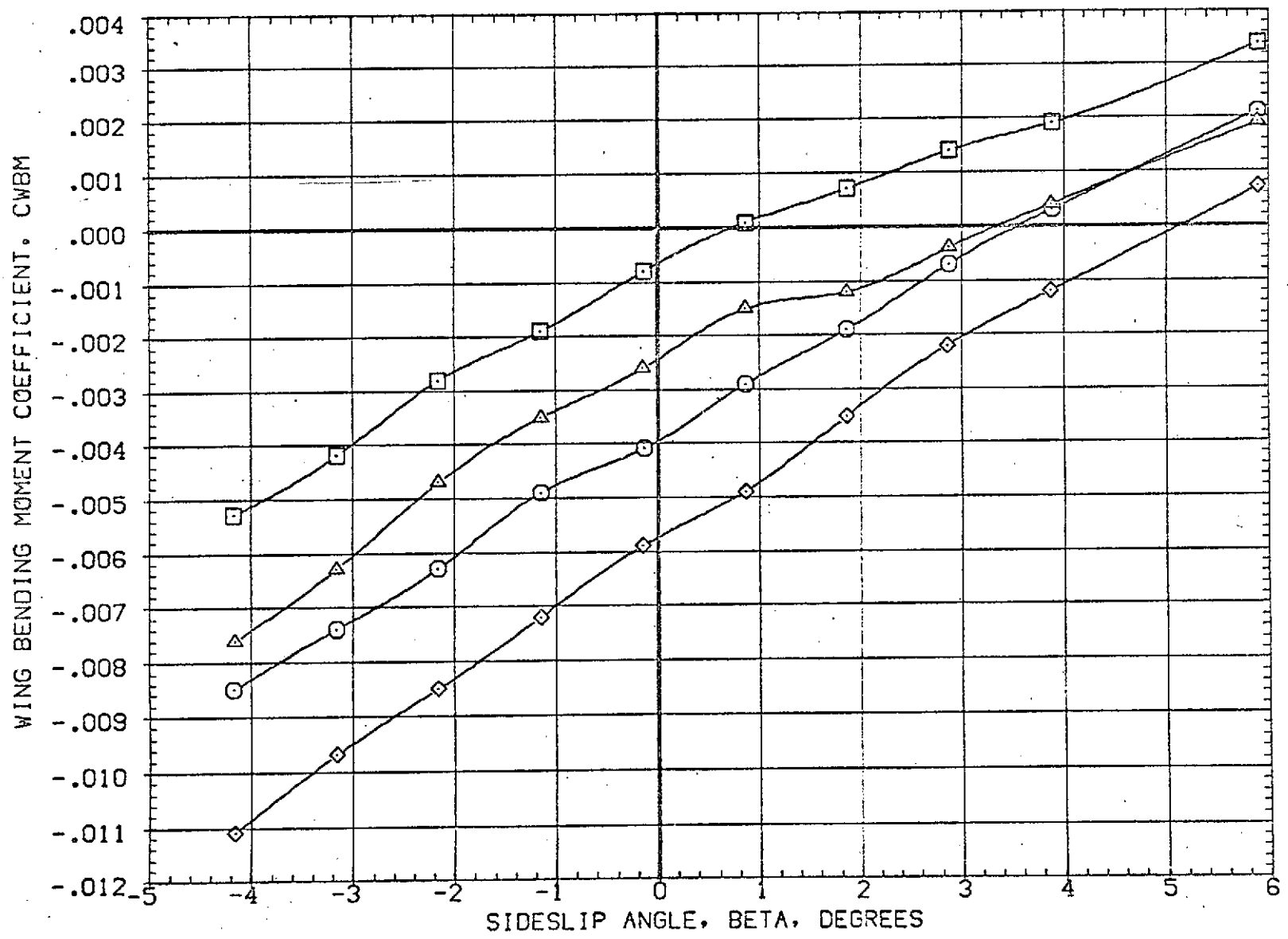

FIG 14 PLUME EFFECTS WITH AND WITHOUT OMS

(A)MACH = 1.60

DATA SET SYMBOL	CONFIGURATION DESCRIPTION	ALPHA	ELEVON	RUDDER	PLUMES	REFERENCE INFORMATION
(RBJ528)	AMES 97-616 1A2 01 TO S1 CMS NO PLUMES	-5.000	.000	.000	.000	SREF 3155.0000 SQ.FT.
(RBJ529)	AMES 97-616 1A2 01 TO S1 CMS NO PLUMES	.000	.000	.000	.000	LREF 50.8000 FT.
(RBJ530)	AMES 97-616 1A2 01 TO S1 CMS NO PLUMES	5.000	.000	.000	.000	BREF 73.5000 FT.
(VBJ028)	AMES 97-616 1A2 01 TO S1 CMS,PC/PT=NCM,SRM A/A=8	-5.000	.000	.000	5.000	XMRP 86.4167 FT.
(VBJ029)	AMES 97-616 1A2 01 TO S1 CMS,PC/PT=NCM,SRM A/A=8	.000	.000	.000	5.000	YMRP .0000 FT.
(VBJ030)	AMES 97-616 1A2 01 TO S1 CMS,PC/PT=NCM,SRM A/A=8	5.000	.000	.000	5.000	ZMRP 4.0000 FT.
						SCALE .0190

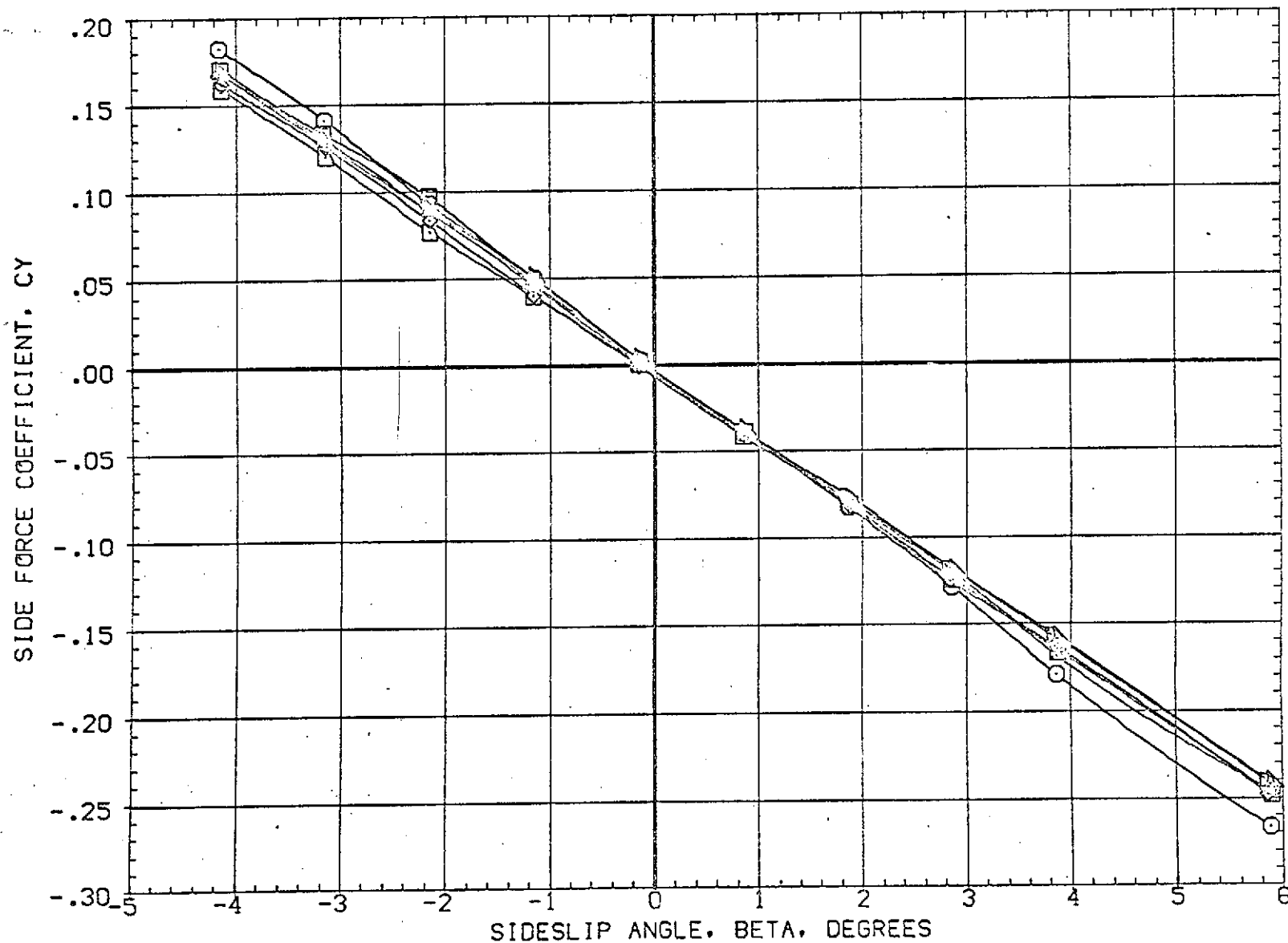

FIG 15 EFFECT OF ALPHA ON LATERAL CHARACTERISTICS WITH PLUMES CMS ON

(A)MACH = 1.60

DATA SET SYMBOL	CONFIGURATION DESCRIPTION	ALPHA	ELEVON	RUDDER	PLUMES	REFERENCE INFORMATION
(R2J528)	AMES 97-616 IA2 01 TO S1 OMS NO PLUMES	-5.000	.000	.000	.000	SREF 3155.0000 SQ.FT.
(R2J529)	AMES 97-616 IA2 01 TO S1 OMS NO PLUMES	.000	.000	.000	.000	LREF 50.8000 FT.
(R2J530)	AMES 97-616 IA2 01 TO S1 OMS NO PLUMES	5.000	.000	.000	.000	BREF 73.5000 FT.
(WB4028)	AMES 97-616 IA2 01 TO S1 OMS, PC/PT=NCM, SRM A/A=8	-5.000	.000	.000	5.000	XMRP 86.4167 FT.
(WB4029)	AMES 97-616 IA2 01 TO S1 OMS, PC/PT=NCM, SRM A/A=8	.000	.000	.000	5.000	YMRP .0000 FT.
(WB4030)	AMES 97-616 IA2 01 TO S1 OMS, PC/PT=NCM, SRM A/A=8	5.000	.000	.000	5.000	ZMRP 4.0000 FT.
						SCALE .0190

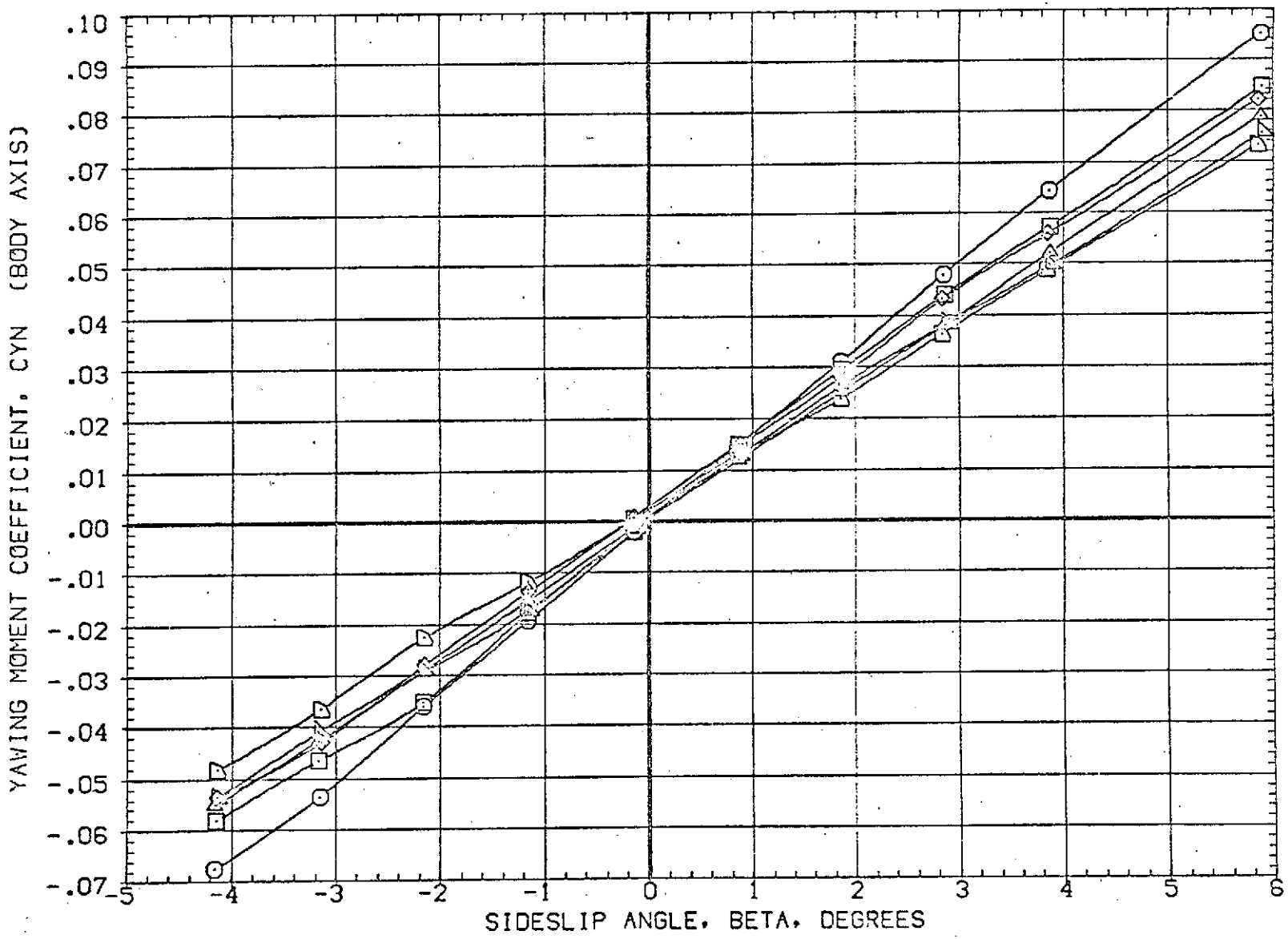

FIG 15 EFFECT OF ALPHA ON LATERAL CHARACTERISTICS WITH PLUMES OMS ON

(A)MACH = 1.60

DATA SET SYMBOL	CONFIGURATION DESCRIPTION	ALPHA	ELEVON	RUDDER	PLUMES	REFERENCE INFORMATION
(RBJ528)	AMES 97-616 1A2 01 TO S1 OMS NO PLUMES	-5.000	.000	.000	.000	SREF 3155.0000 SQ.FT.
(RBJ529)	AMES 97-616 1A2 01 TO S1 OMS NO PLUMES	.000	.000	.000	.000	LREF 50.8000 FT.
(RBJ530)	AMES 97-616 1A2 01 TO S1 OMS NO PLUMES	5.000	.000	.000	.000	BREF 73.5000 FT.
(VBJ028)	AMES 97-616 1A2 01 TO S1 OMS,PC/PT=NDM,SRM A/A=8	-5.000	.000	.000	5.000	XMRP 86.4167 FT.
(VBJ029)	AMES 97-616 1A2 01 TO S1 OMS,PC/PT=NDM,SRM A/A=8	.000	.000	.000	5.000	YMRP .0000 FT.
(VBJ030)	AMES 97-616 1A2 01 TO S1 OMS,PC/PT=NDM,SRM A/A=8	5.000	.000	.000	5.000	ZMRP 4.0000 FT.
						SCALE .0190

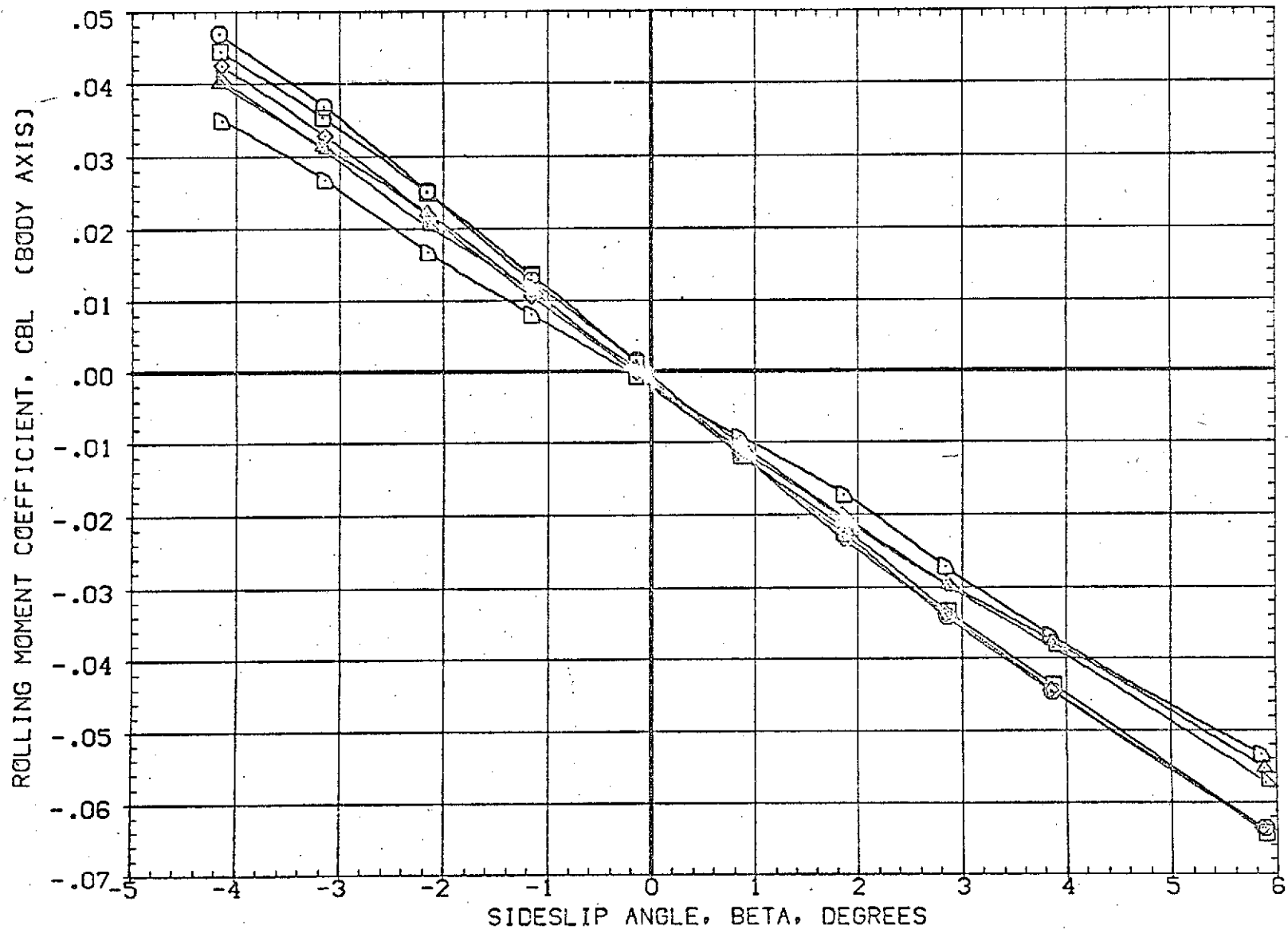

FIG 15 EFFECT OF ALPHA ON LATERAL CHARACTERISTICS WITH PLUMES OMS ON

(A)MACH = 1.60

DATA SET SYMBOL	CONFIGURATION DESCRIPTION	ALPHA	ELEVON	RUDDER	PLUMES	REFERENCE INFORMATION		
(R2J528)	AMES 97-616 1A2 01 TO S1 OMS NO PLUMES	-5.000	.000	.000	.000	SREF	3155.0000	50. FT.
(R2J529)	AMES 97-616 1A2 01 TO S1 OMS NO PLUMES	5.000	.000	.000	.000	LREF	50.8000	73.5000 FT.
(R2J530)	AMES 97-616 1A2 01 TO S1 OMS NO PLUMES	5.000	.000	.000	.000	BREF	73.5000	86.4167 FT.
(VBJ028)	AMES 97-616 1A2 01 TO S1 OMS, PC/PT=NGM, SRM A/A=8	-5.000	.000	.000	5.000	XMRP	.0000	4.0000 FT.
(VBJ029)	AMES 97-616 1A2 01 TO S1 OMS, PC/PT=NGM, SRM A/A=8	5.000	.000	.000	5.000	YMRP	4.0000	SCALE .0190
(VBJ030)	AMES 97-616 1A2 01 TO S1 OMS, PC/PT=NGM, SRM A/A=8	5.000	.000	.000	5.000	ZMRP		

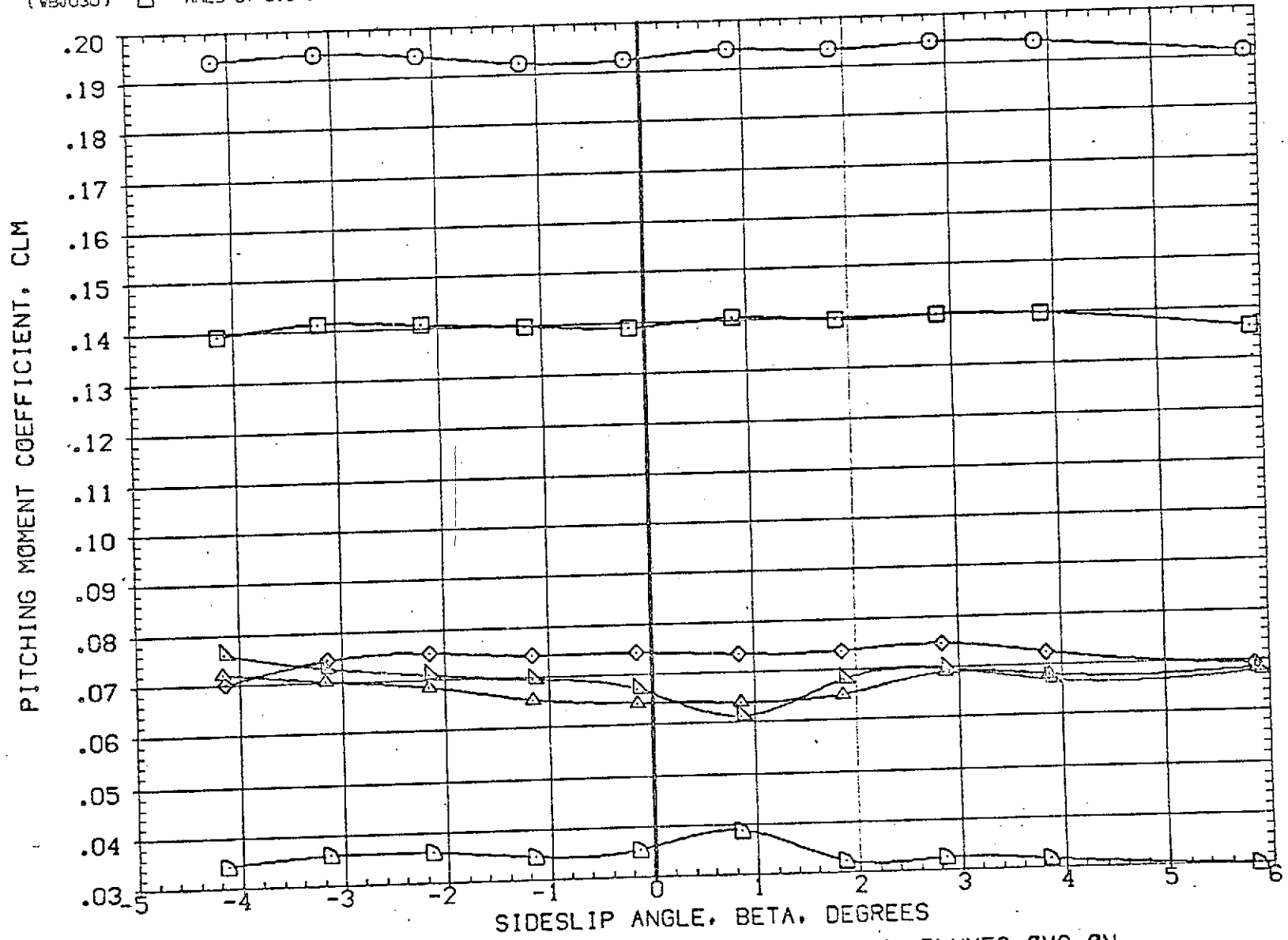

FIG 15 EFFECT OF ALPHA ON LATERAL CHARACTERISTICS WITH PLUMES OMS ON

(A) MACH = 1.60

DATA SET SYMBOL	CONFIGURATION DESCRIPTION	ALPHA	ELEVON	RUDDER	PLUMES	REFERENCE INFORMATION
(RBJ528)	AMES 97-616 1A2 01 TO S1 OMS NO PLUMES	-5.000	.000	.000	.000	SREF 3155.0000 SQ.FT.
(RBJ529)	AMES 97-616 1A2 01 TO S1 OMS NO PLUMES	.000	.000	.000	.000	LREF 50.8000 FT.
(RBJ530)	AMES 97-616 1A2 01 TO S1 OMS NO PLUMES	5.000	.000	.000	.000	BREF 73.5000 FT.
(VBJ028)	AMES 97-616 1A2 01 TO S1 OMS, PC/PT=NOM, SRM A/A=8	-5.000	.000	.000	5.000	XMRP 86.4167 FT.
(VBJ029)	AMES 97-616 1A2 01 TO S1 OMS, PC/PT=NOM, SRM A/A=8	.000	.000	.000	5.000	YMRP .0000 FT.
(VBJ030)	AMES 97-616 1A2 01 TO S1 OMS, PC/PT=NOM, SRM A/A=8	5.000	.000	.000	5.000	ZMRP 4.0000 FT.
						SCALE .0190

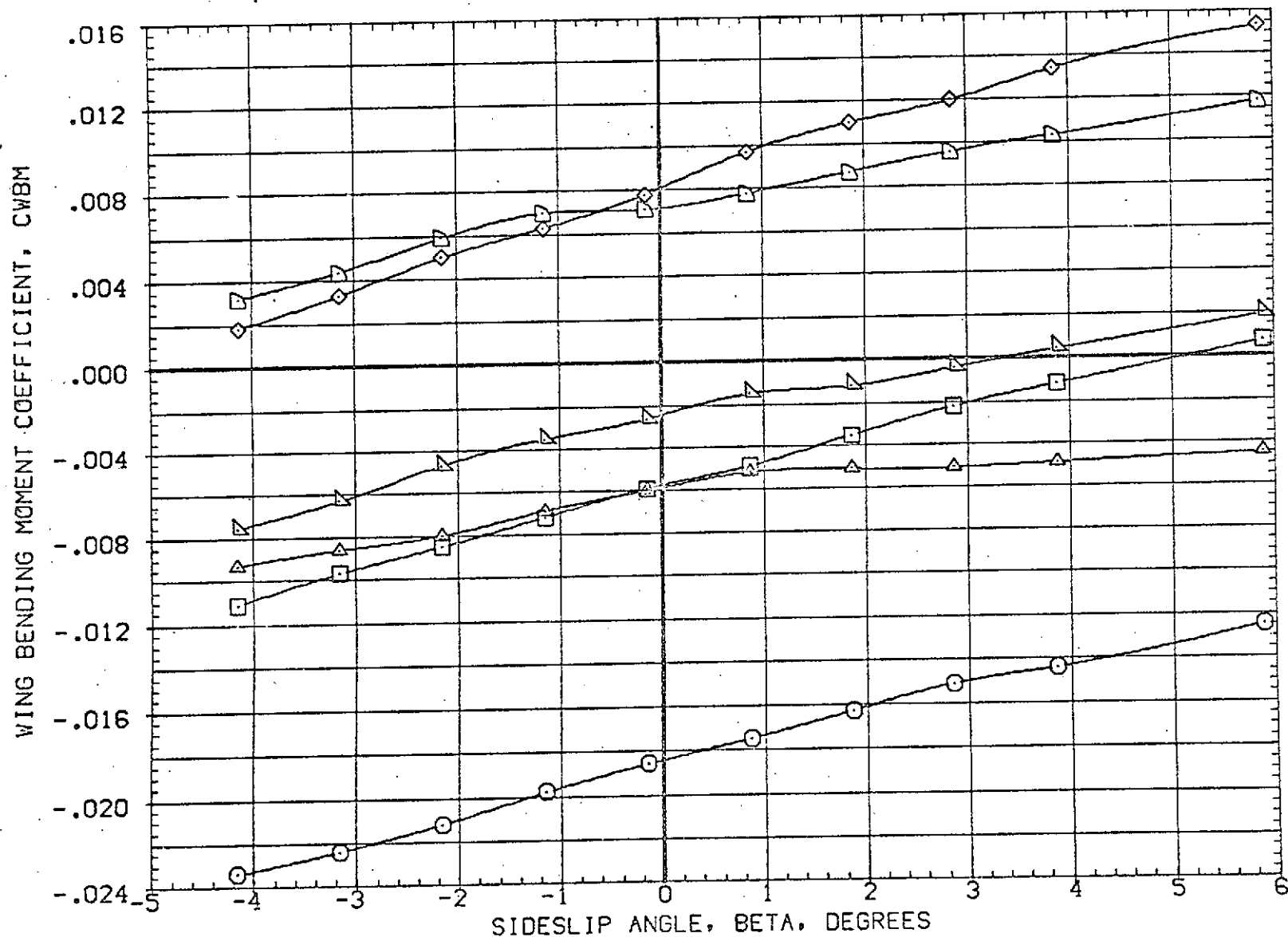

FIG 15 EFFECT OF ALPHA ON LATERAL CHARACTERISTICS WITH PLUMES OMS ON
 (A) MACH = 1.60

DATA SET SYMBOL	CONFIGURATION DESCRIPTION	ALPHA	ELEVON	RUDDER	PLUMES	REFERENCE INFORMATION
(RB)525)	AMES 97-616 1A2 01 TO S1 NO PLUMES	5.000	.000	.000	.000	SREF 3155.0000 50.FT.
(FB)502)	AMES 97-616 1A2 01 TO S1 NO PLUMES	5.000	.000	.000	.000	LREF 50.8000 FT.
(RB)524)	AMES 97-616 1A2 01 TO S1 NO PLUMES	-5.000	.000	.000	.000	BREF 73.5000 FT.
(RB)025)	AMES 97-616 1A2 01 TO S1 PC/PT-NOM,SRM A/A=8	-5.000	.000	.000	5.000	XMRP 86.4167 FT.
(FB)002)	AMES 97-616 1A2 01 TO S1 PC/PT-NOM,SRM A/A=8	5.000	.000	.000	5.000	YMRP .0000 FT.
(RB)026)	AMES 97-616 1A2 01 TO S1 PC/PT-NOM,SRM A/A=8	5.000	.000	.000	5.000	ZMRP 4.0000 FT.
						SCALE .0190

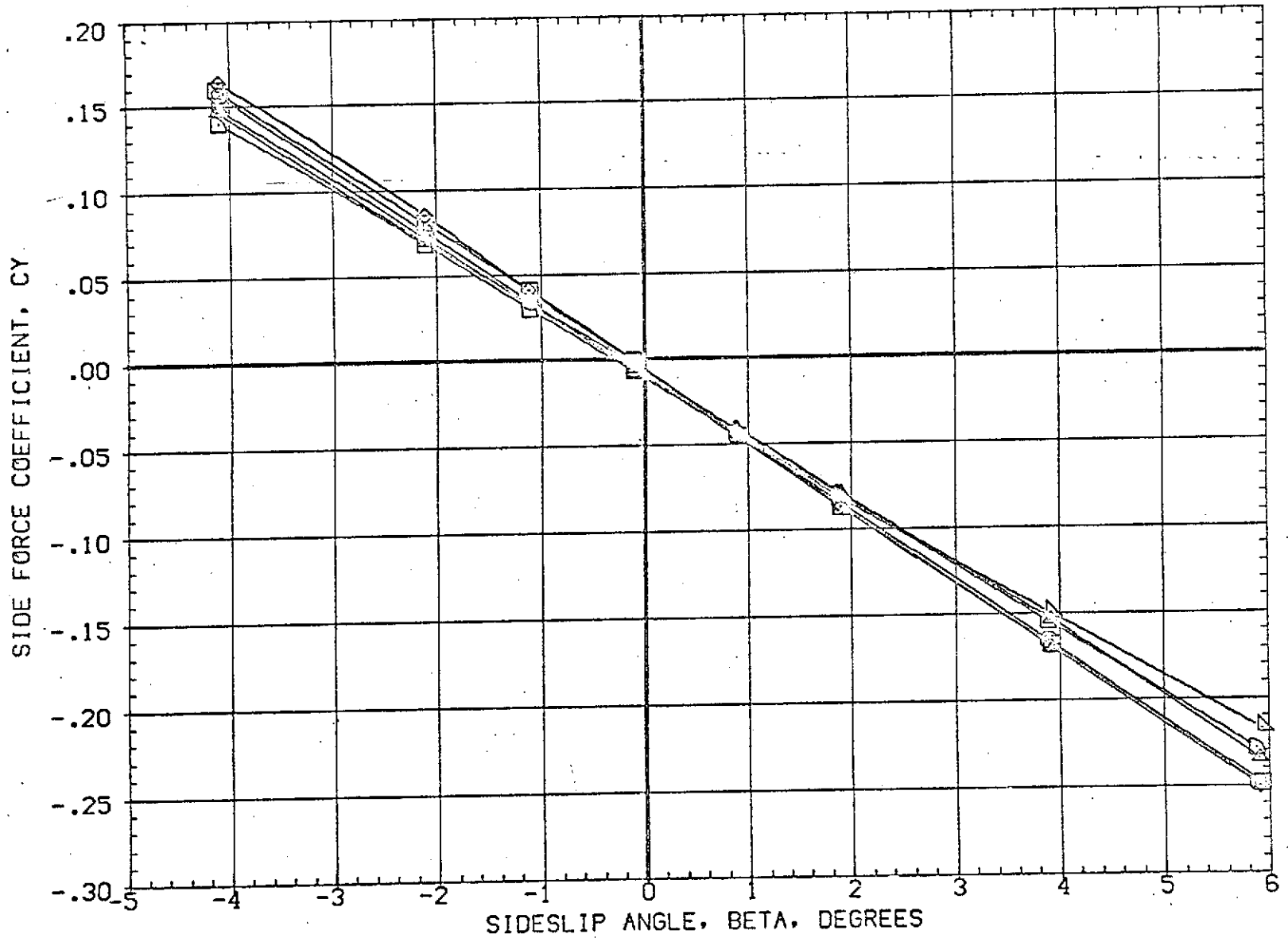

FIG 16 EFFECT OF ALPHA ON LATERAL CHARACTERISTICS WITH PLUMES ON/OFF

(A)MACH = 1.98

DATA SET SYMBOL	CONFIGURATION DESCRIPTION	ALPHA	ELEVON	RUDDER	PLUMES	REFERENCE INFORMATION
(RBJS25)	AMES 97-616 IA2 01 TO S1 NO PLUMES	5.000	.000	.000	.000	SREF 3155.0000 SQ.FT.
(FBJS02)	AMES 97-616 IA2 01 TO S1 NO PLUMES	5.000	.000	.000	.000	LREF 50.8000 FT.
(RBJS24)	AMES 97-616 IA2 01 TO S1 NO PLUMES	-5.000	.000	.000	.000	BREF 73.5000 FT.
(RBJS25)	AMES 97-616 IA2 01 TO S1 NO PLUMES	-5.000	.000	.000	.000	XMRP 66.4167 FT.
(FBJS02)	AMES 97-616 IA2 01 TO S1 PC/PT=NDM,SRM A/A=8	5.000	.000	.000	5.000	YMRP 4.0000 FT.
(RBJS26)	AMES 97-616 IA2 01 TO S1 PC/PT=NDM,SRM A/A=8	5.000	.000	.000	5.000	ZMRP 4.0000 FT.
						SCALE .0190

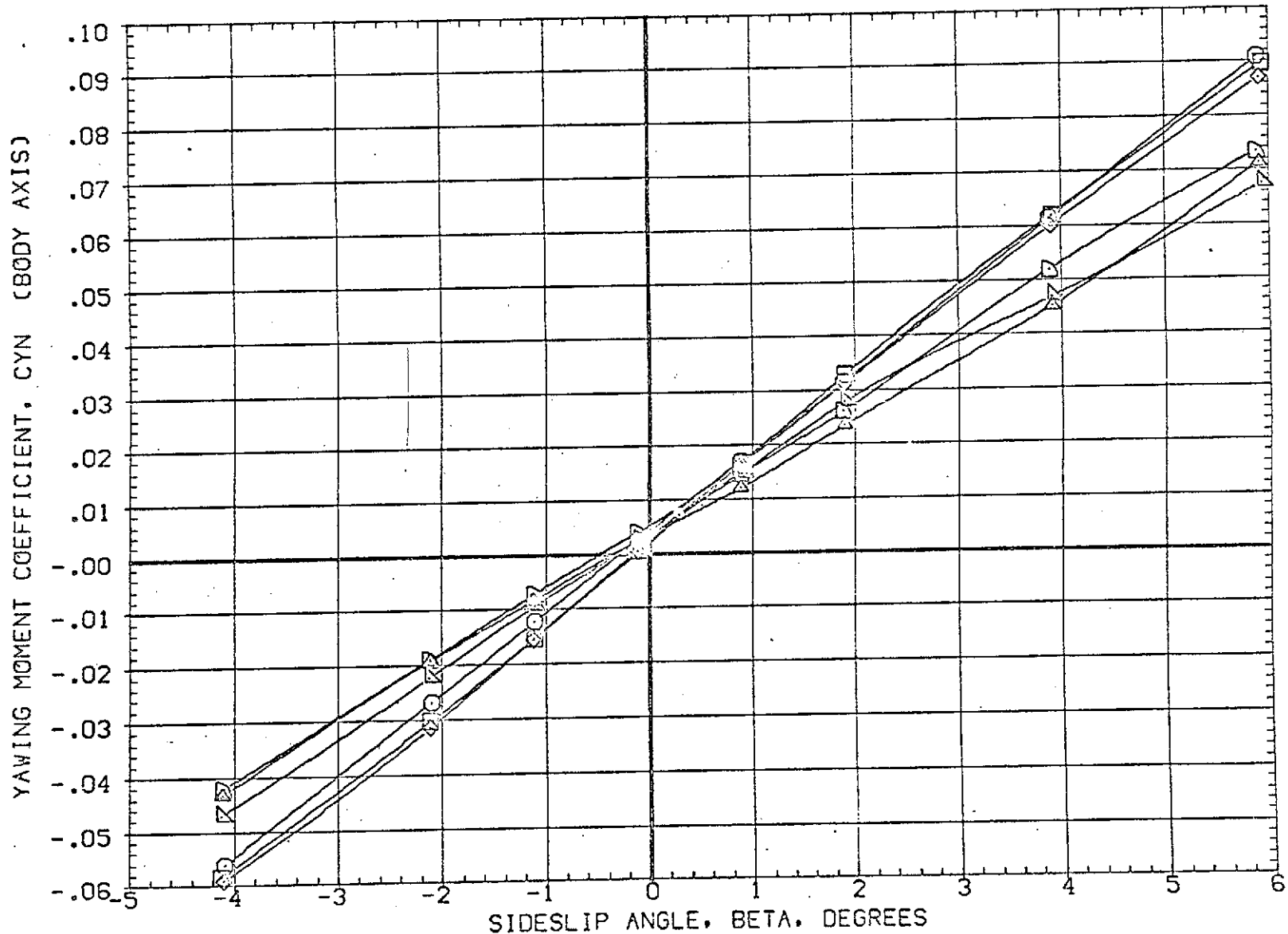

FIG 16 EFFECT OF ALPHA ON LATERAL CHARACTERISTICS WITH PLUMES OMS OFF

(A)MACH = 1.98

DATA SET SYMBOL	CONFIGURATION DESCRIPTION	ALPHA	ELEVON	RUDDER	PLUMES	REFERENCE INFORMATION
(RBJ525)	AMES 97-616 1A2 01 TO S1 NO PLUMES	5.000	.000	.000	.000	SREF 3155.0000 SQ.FT.
(FBJ502)	AMES 97-616 1A2 01 TO S1 NO PLUMES	5.000	.000	.000	.000	LREF 50.8000 FT.
(RBJ524)	AMES 97-616 1A2 01 TO S1 NO PLUMES	5.000	.000	.000	.000	BREF 73.5000 FT.
(RBJ025)	AMES 97-616 1A2 01 TO S1 PC/PT-NOM. SRM A/A=8	5.000	.000	.000	5.000	XMRP 86.4167 FT.
(FBJ002)	AMES 97-616 1A2 01 TO S1 PC/PT-NOM. SRM A/A=8	5.000	.000	.000	5.000	YMRP .0000 FT.
(RBJ026)	AMES 97-616 1A2 01 TO S1 PC/PT-NOM. SRM A/A=8	5.000	.000	.000	5.000	ZMRP 4.0000 FT.
						SCALE .0190

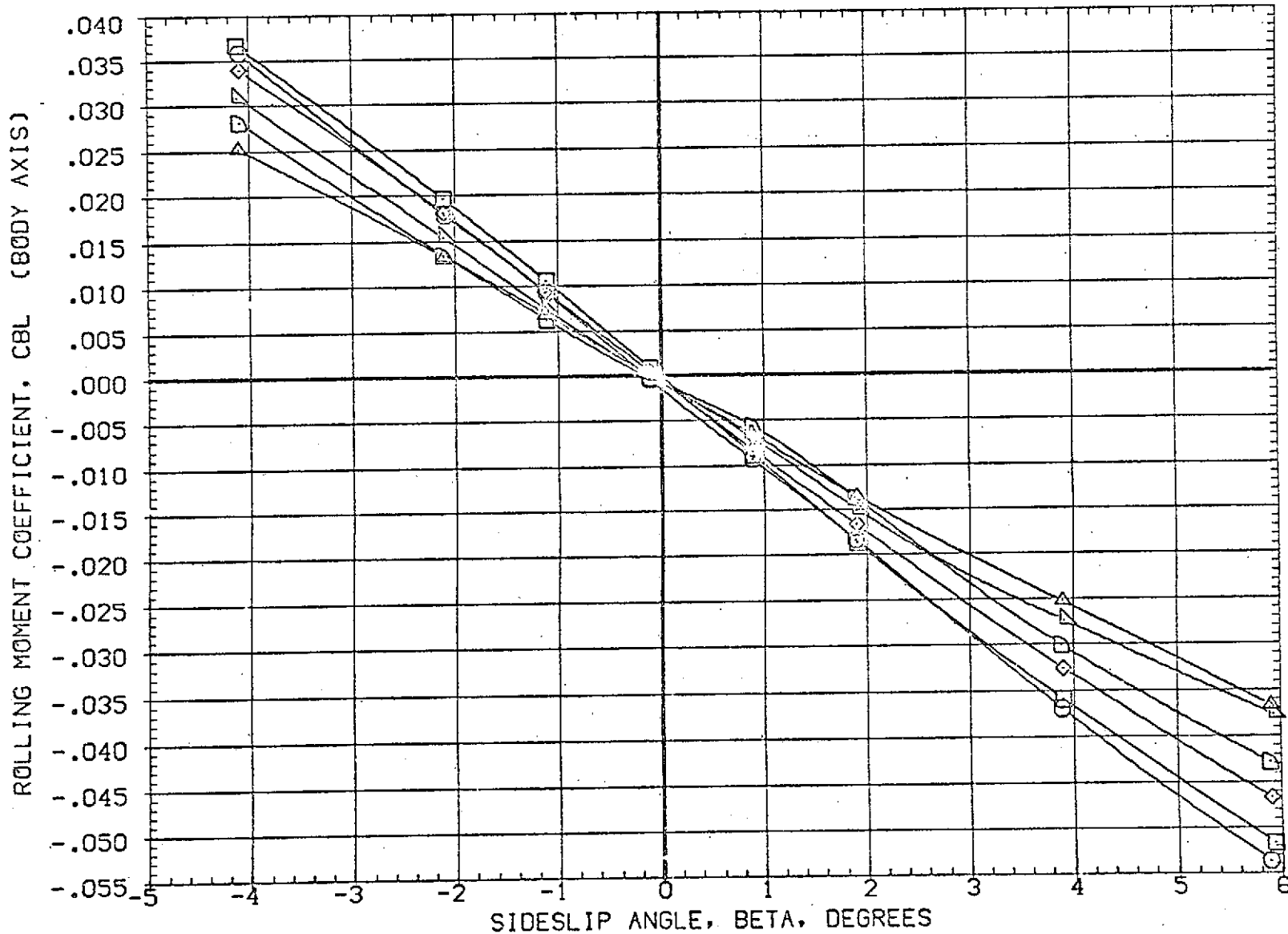

FIG 16 EFFECT OF ALPHA ON LATERAL CHARACTERISTICS WITH PLUMES OMS OFF

(A)MACH = 1.98

DATA SET SYMBOL	CONFIGURATION DESCRIPTION	ALPHA	ELEVON	RUDDER	PLUMES	REFERENCE INFORMATION
(RBJ525)	AMES 97-616 1A2 01 TO S1 NO PLUMES	5.000	.000	.000	.000	SREF 3155.0000 SQ.FT.
(FBJ502)	AMES 97-616 1A2 01 TO S1 NO PLUMES	.000	.000	.000	.000	LREF 50.8000 FT.
(RBJ524)	AMES 97-616 1A2 01 TO S1 NO PLUMES	-5.000	.000	.000	.000	BREF 73.5000 FT.
(RBJ025)	AMES 97-616 1A2 01 TO S1 PC/PT=NDM, SRM A/A=8	-5.000	.000	.000	5.000	XMRP 86.4167 FT.
(FBJ002)	AMES 97-616 1A2 01 TO S1 PC/PT=NDM, SRM A/A=8	.000	.000	.000	5.000	YMRP .0000 FT.
(RBJ026)	AMES 97-616 1A2 01 TO S1 PC/PT=NDM, SRM A/A=8	5.000	.000	.000	5.000	ZMRP 4.0000 FT.
						SCALE .0190

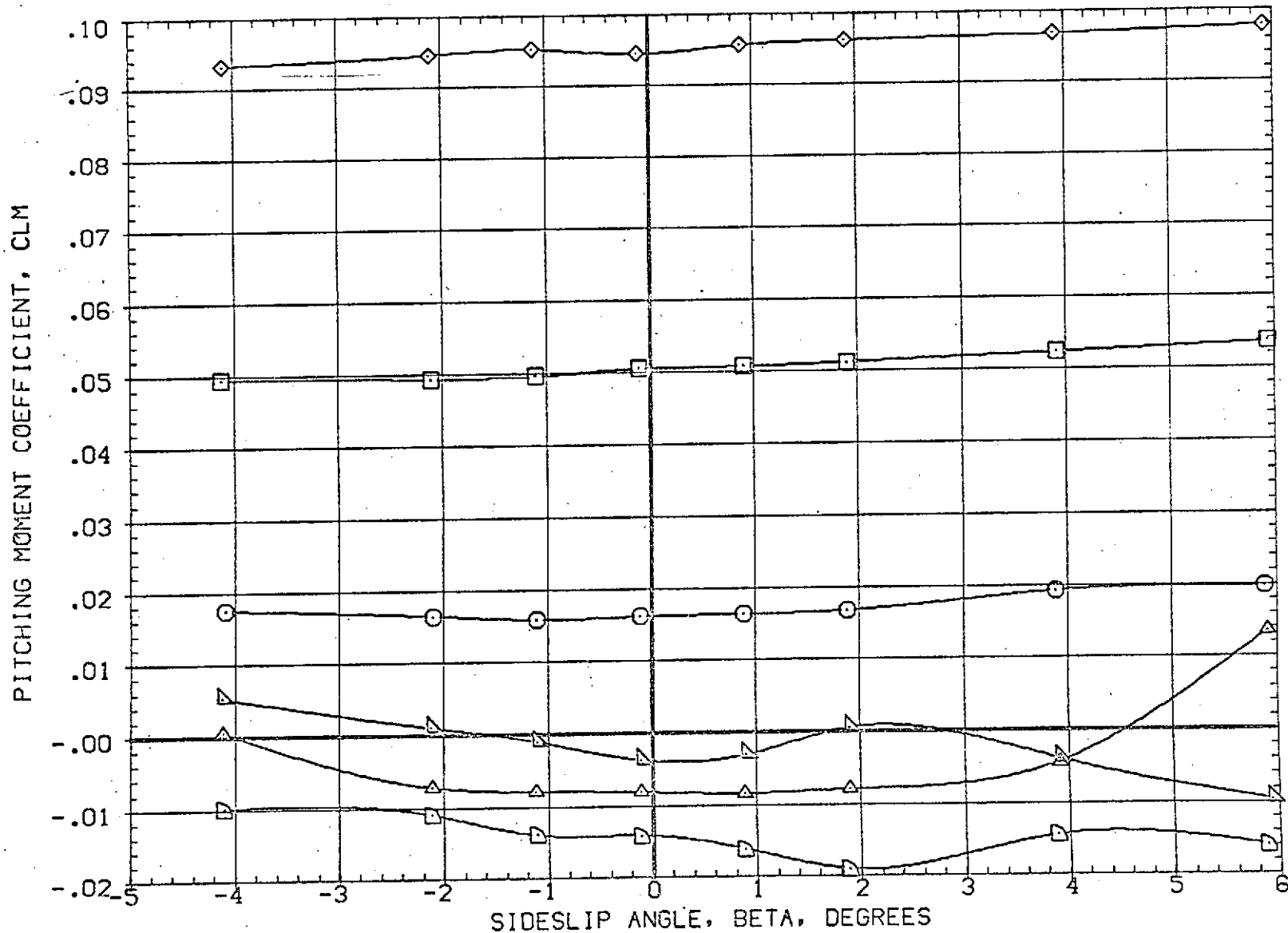

FIG 16 EFFECT OF ALPHA ON LATERAL CHARACTERISTICS WITH PLUMES ON/OFF

(A) MACH = 1.98

DATA SET SYMBOL	CONFIGURATION DESCRIPTION	ALPHA	ELEVON	RUDDER	PLUMES	REFERENCE INFORMATION		
(RBJ525)	AMES 97-616 IA2 01 TO S1 NO PLUMES	5.000	.000	.000	.000	SREF	3155.0000	50. FT.
(FBJ502)	AMES 97-616 IA2 01 TO S1 NO PLUMES	.000	.000	.000	.000	LREF	50.8000	FT.
(RBJ524)	AMES 97-616 IA2 01 TO S1 NO PLUMES	-5.000	.000	.000	.000	BREF	73.5000	FT.
(RBJ025)	AMES 97-616 IA2 01 TO S1 PC/PT=NGM,SRM A/A=8	-5.000	.000	.000	5.000	XMRP	86.4167	FT.
(FBJ002)	AMES 97-616 IA2 01 TO S1 PC/PT=NGM,SRM A/A=8	.000	.000	.000	5.000	YMRP	.0000	FT.
(RBJ026)	AMES 97-616 IA2 01 TO S1 PC/PT=NGM,SRM A/A=8	5.000	.000	.000	5.000	ZMRP	4.0000	FT.
						SCALE	.0190	

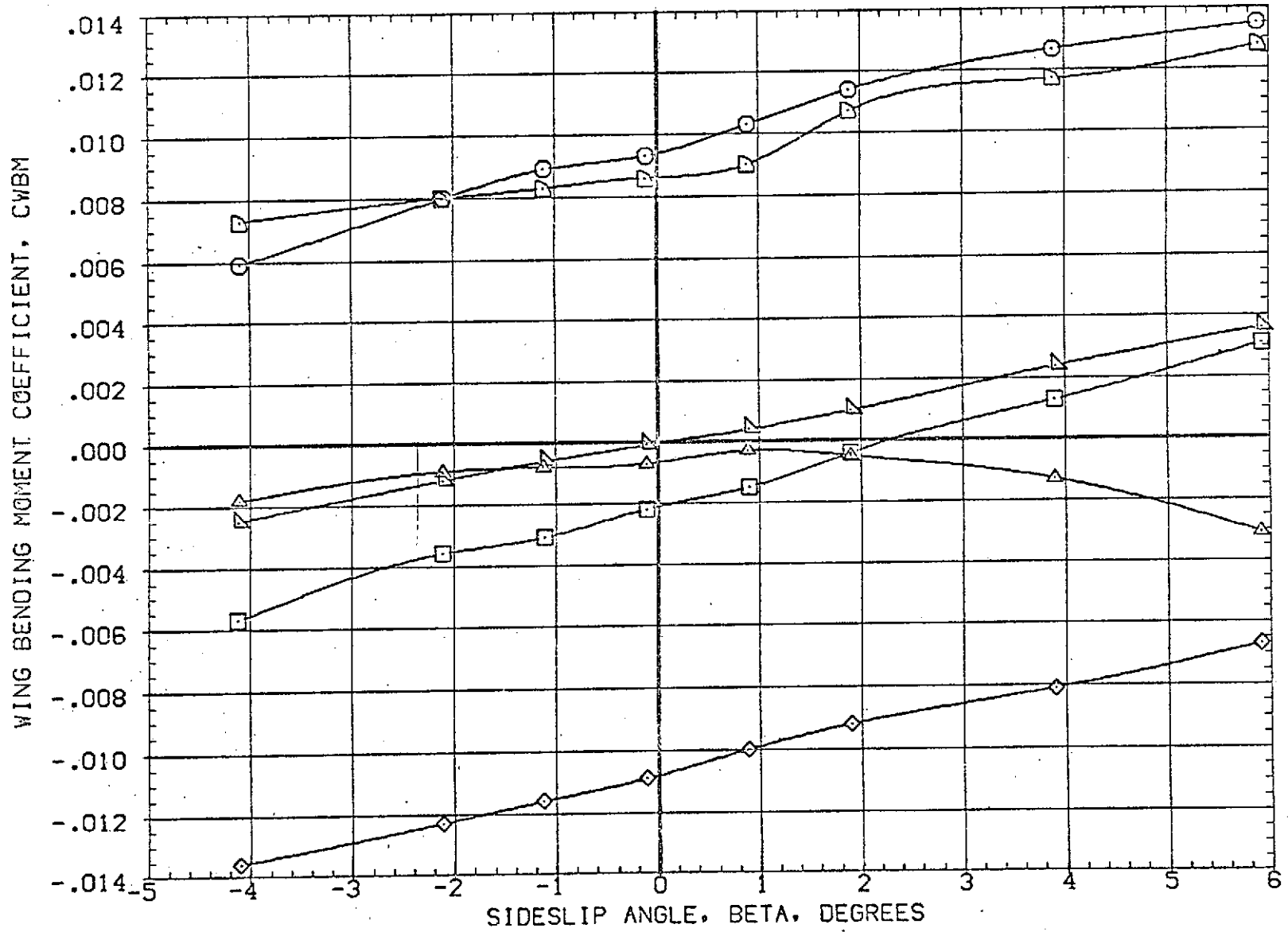

FIG 16 EFFECT OF ALPHA ON LATERAL CHARACTERISTICS WITH PLUMES OMS OFF

(A) MACH = 1.98

DATA SET SYMBOL	CONFIGURATION DESCRIPTION	ELEVON	AILERON	RUDDER	PLUMES	REFERENCE INFORMATION
(RBJS01)	AMES 97-616 IA2 01 TO S1 NO PLUMES	.000	.000	.000	.000	SREF 3155.0000 SQ.FT.
(RBJS11)	AMES 97-616 IA2 01 TO S1 NO PLUMES	10.000	.000	10.000	.000	LREF 50.8000 FT.
(RBJS21)	AMES 97-616 IA2 01 TO S1 NO PLUMES	-10.000	.000	10.000	.000	BREF 73.5000 FT.
(RBJ001)	AMES 97-616 IA2 01 TO S1 PC/PT-NOM SRM A/A-8	.000	.000	.000	5.000	XMRP 86.4167 FT.
(RBJ011)	AMES 97-616 IA2 01 TO S1 PC/PT-NOM SRM A/A-8	10.000	.000	10.000	5.000	YMRP .0000 FT.
(RBJ021)	AMES 97-616 IA2 01 TO S1 PC/PT-NOM SRM A/A-8	-10.000	.000	10.000	5.000	ZMRP 4.0000 FT.
						SCALE .0190

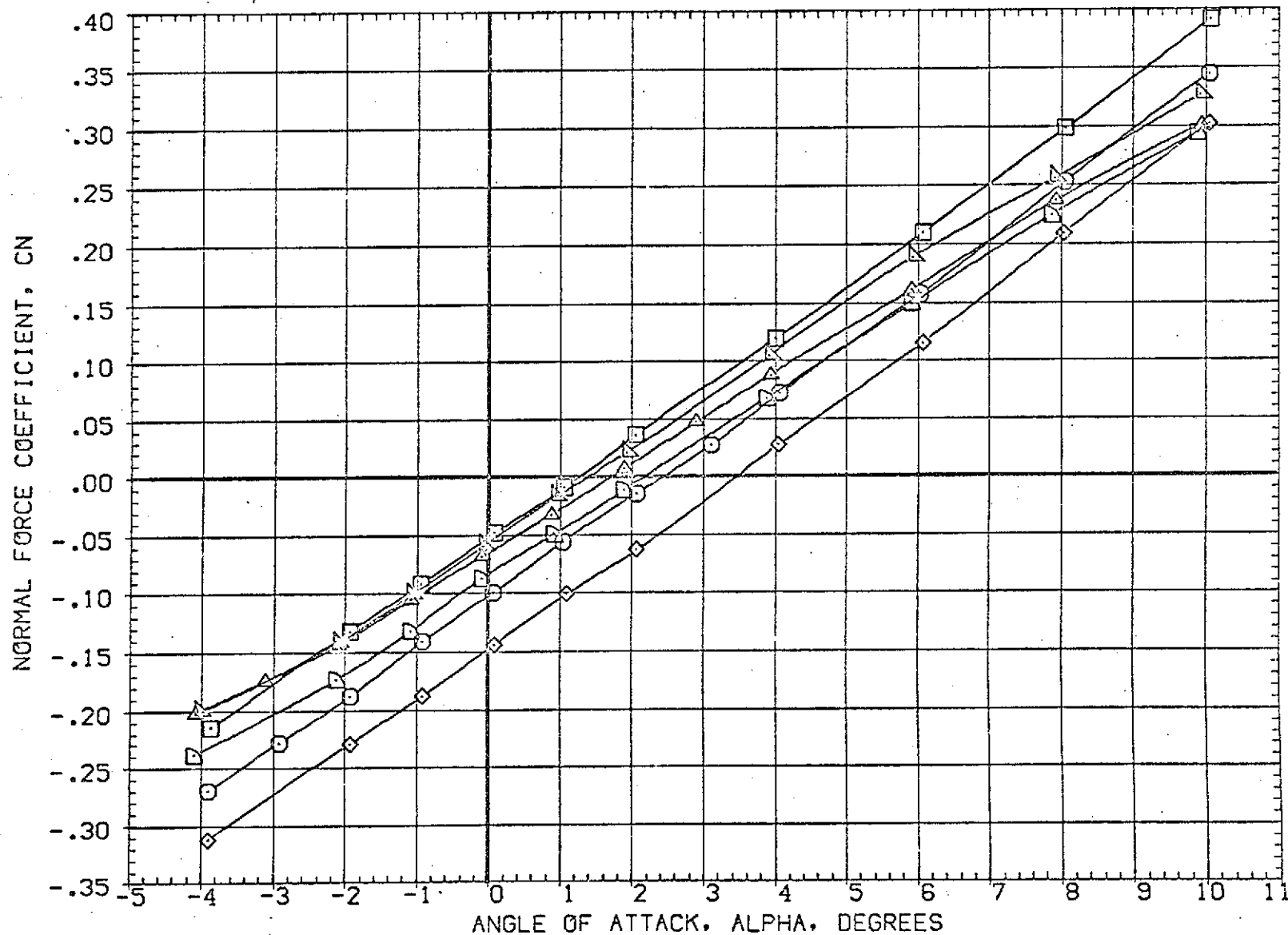

FIG 17 EFFECT OF PLUMES ON ELEVON AND RUDDER POWER, BETA=0.0

(A)MACH = 1.60

DATA SET SYMBOL	CONFIGURATION DESCRIPTION	ELEVON	AILRON	RUDDER	PLUMES	REFERENCE INFORMATION
(RBJ501)	AMES 97-616 1A2 01 TO S1 NO PLUMES	.000	.000	.000	.000	SREF 3155.0000 SQ.FT.
(RBJ511)	AMES 97-616 1A2 01 TO S1 NO PLUMES	10.000	.000	10.000	.000	LREF 50.8000 FT.
(RBJ521)	AMES 97-616 1A2 01 TO S1 NO PLUMES	-10.000	.000	10.000	.000	BREF 73.5000 FT.
(RBJ001)	AMES 97-616 1A2 01 TO S1 PC/PT-NOM, SRM A/A=8	.000	.000	.000	5.000	XMRP 86.4167 FT.
(RBJ011)	AMES 97-616 1A2 01 TO S1 PC/PT-NOM, SRM A/A=8	10.000	.000	10.000	5.000	YMRP .0000 FT.
(RBJ021)	AMES 97-616 1A2 01 TO S1 PC/PT-NOM, SRM A/A=8	-10.000	.000	10.000	5.000	ZMRP 4.0000 FT.
						SCALE .0190

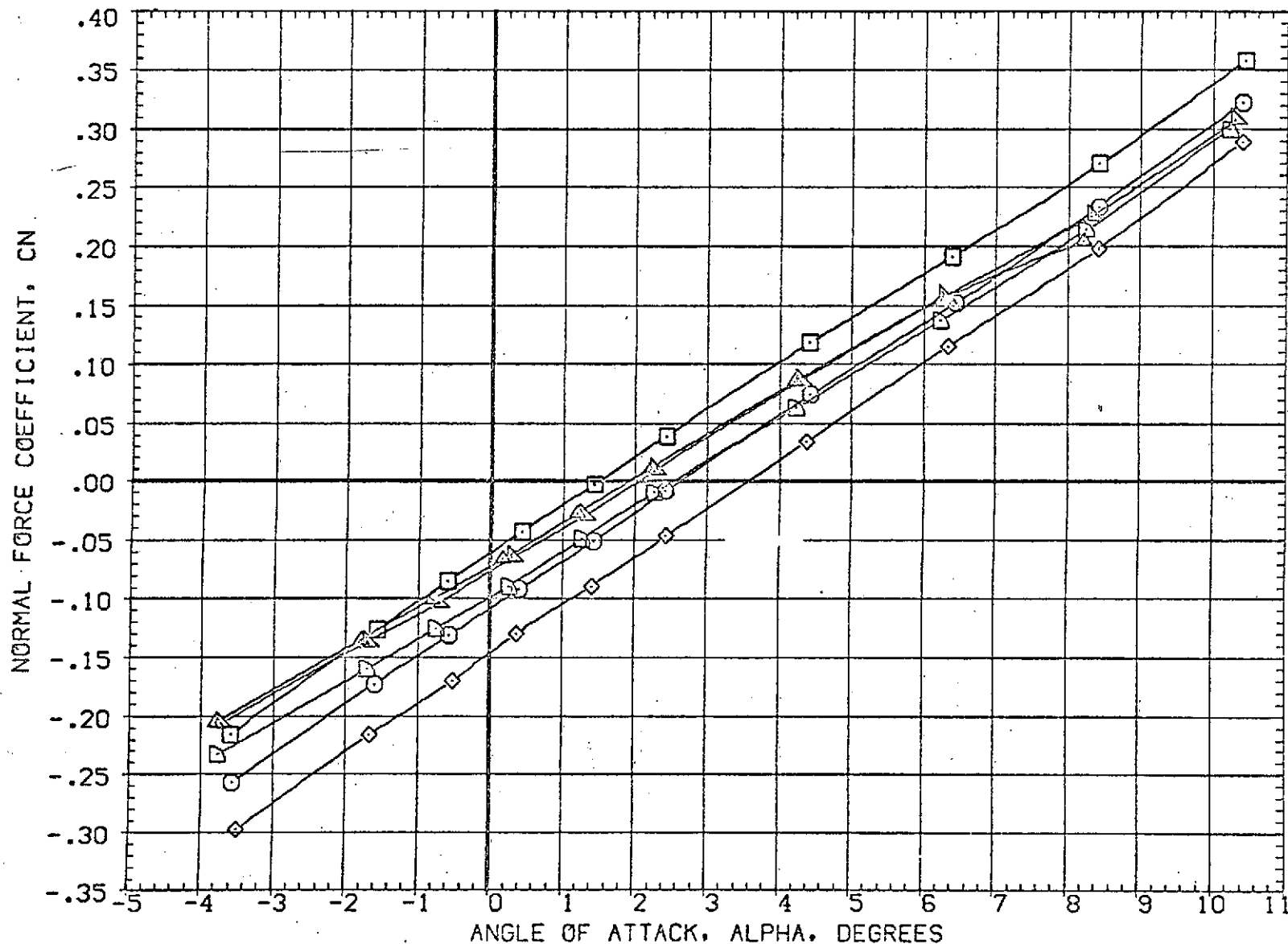

FIG 17 EFFECT OF PLUMES ON ELEVON AND RUDDER POWER, BETA=0.0

(B)MACH = 1.98

DATA SET SYMBOL	CONFIGURATION DESCRIPTION	ELEVON	AILERON	RUDDER	PLUMES	REFERENCE INFORMATION
(RBJ501)	AMES 97-616 1A2 01 TO S1 NO PLUMES	.000	.000	.000	.000	SREF 3155.0000 SQ.FT.
(RBJ511)	AMES 97-616 1A2 01 TO S1 NO PLUMES	10.000	.000	10.000	.000	LREF 50.8000 FT.
(RBJ521)	DATA NOT AVAILABLE	-10.000	.000	10.000	.000	BREF 73.5000 FT.
(RBJ001)	AMES 97-616 1A2 01 TO S1 PC/PT NOM. SRM A/A=8	.000	.000	.000	5.000	XMRP 86.4167 FT.
(RBJ011)	AMES 97-616 1A2 01 TO S1 PC/PT=NOM. SRM A/A=8	10.000	.000	10.000	5.000	YMRP .0000 FT.
(RBJ021)	DATA NOT AVAILABLE	-10.000	.000	10.000	5.000	ZMRP 4.0000 FT.
						SCALE .0190

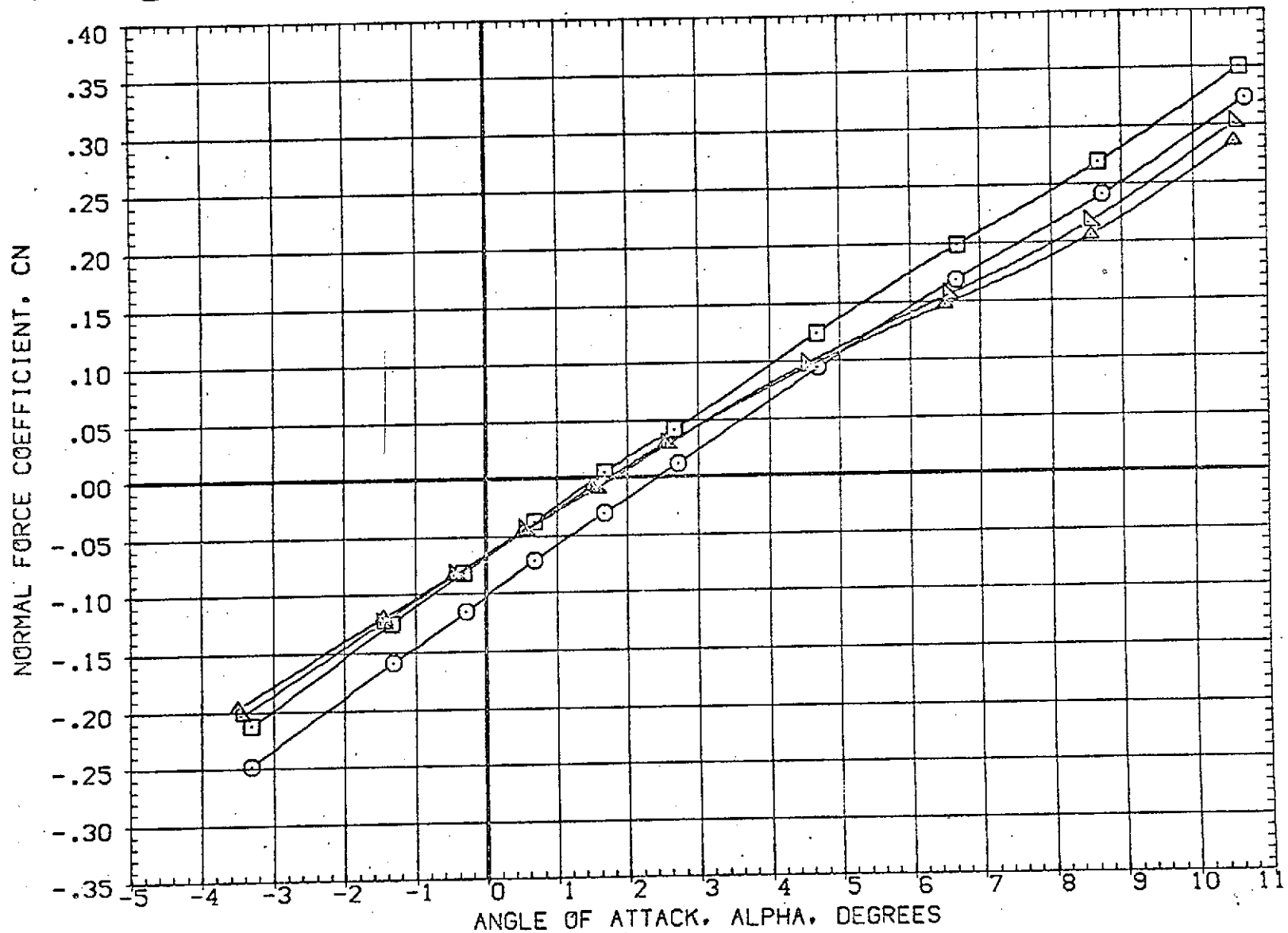

FIG 17 EFFECT OF PLUMES ON ELEVON AND RUDDER POWER, BETA=0.0

(C)MACH = 2.17

DATA SET SYMBOL	CONFIGURATION DESCRIPTION	ELEVON	AILERON	RUDDER	PLUMES	REFERENCE INFORMATION	
(RBJ501)	AMES 97-616 1A2 01 TO S1 NO PLUMES	.000	.000	.000	.000	SREF	3155.0000 SQ.FT.
(RBJ511)	AMES 97-616 1A2 01 TO S1 NO PLUMES	10.000	.000	10.000	.000	LREF	50.8000 FT.
(RBJ521)	AMES 97-616 1A2 01 TO S1 NO PLUMES	-10.000	.000	10.000	.000	BREF	73.5000 FT.
(RBJC01)	AMES 97-616 1A2 01 TO S1 PC/PT NOM SRM A/A=8	.000	.000	.000	5.000	XMRP	86.4167 FT.
(RBJO11)	AMES 97-616 1A2 01 TO S1 PC/PT=NOM SRM A/A=8	10.000	.000	10.000	5.000	YMRP	.0000 FT.
(RBJO21)	AMES 97-616 1A2 01 TO S1 PC/PT=NOM SRM A/A=8	-10.000	.000	10.000	5.000	ZMRP	4.0000 FT.
						SCALE	.0190

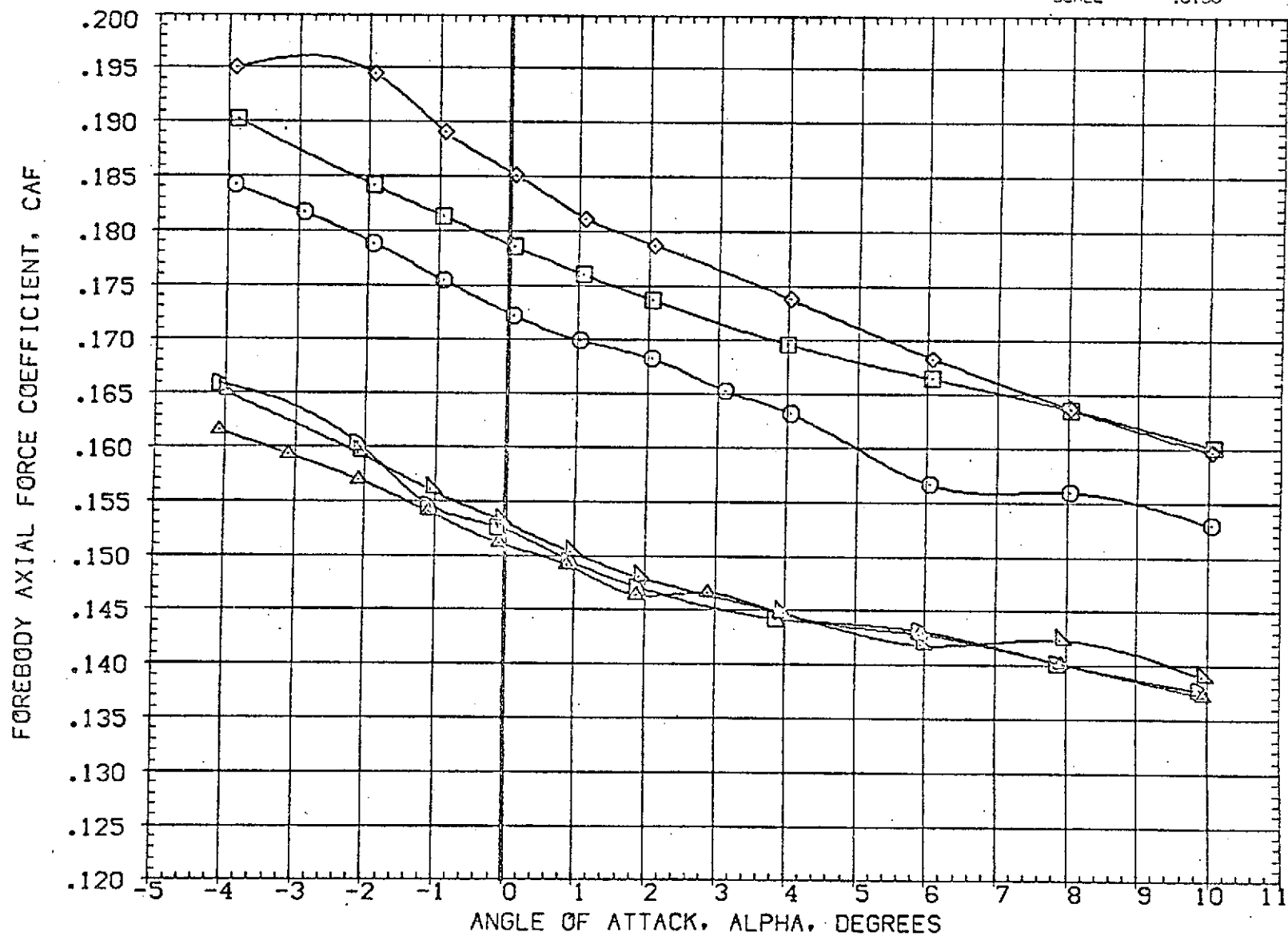

FIG 17 EFFECT OF PLUMES ON ELEVON AND RUDDER POWER, BETA=0.0

(A)MACH = 1.60

DATA SET SYMBOL	CONFIGURATION DESCRIPTION	ELEVON	AILRON	RUDDER	PLUMES	REFERENCE INFORMATION
(RBJ501)	AMES 97-616 IA2 01 TO S1 NO PLUMES	.000	.000	.000	.000	SREF 3155.0000 SQ.FT.
(RBJ511)	AMES 97-616 IA2 01 TO S1 NO PLUMES	-10.000	.000	10.000	.000	LREF 50.9000 FT.
(RBJ521)	AMES 97-616 IA2 01 TO S1 NO PLUMES	-10.000	.000	10.000	.000	BREF 73.5000 FT.
(RBJ001)	AMES 97-616 IA2 01 TO S1 PC/PT-NOM SRM A/A=8	.000	.000	.000	5.000	XMRP 85.4167 FT.
(RBJ011)	AMES 97-616 IA2 01 TO S1 PC/PT-NOM SRM A/A=8	-10.000	.000	10.000	5.000	YMRP .0000 FT.
(RBJ021)	AMES 97-616 IA2 01 TO S1 PC/PT-NOM SRM A/A=8	-10.000	.000	10.000	5.000	ZMRP 4.0000 FT.
						SCALE .0190

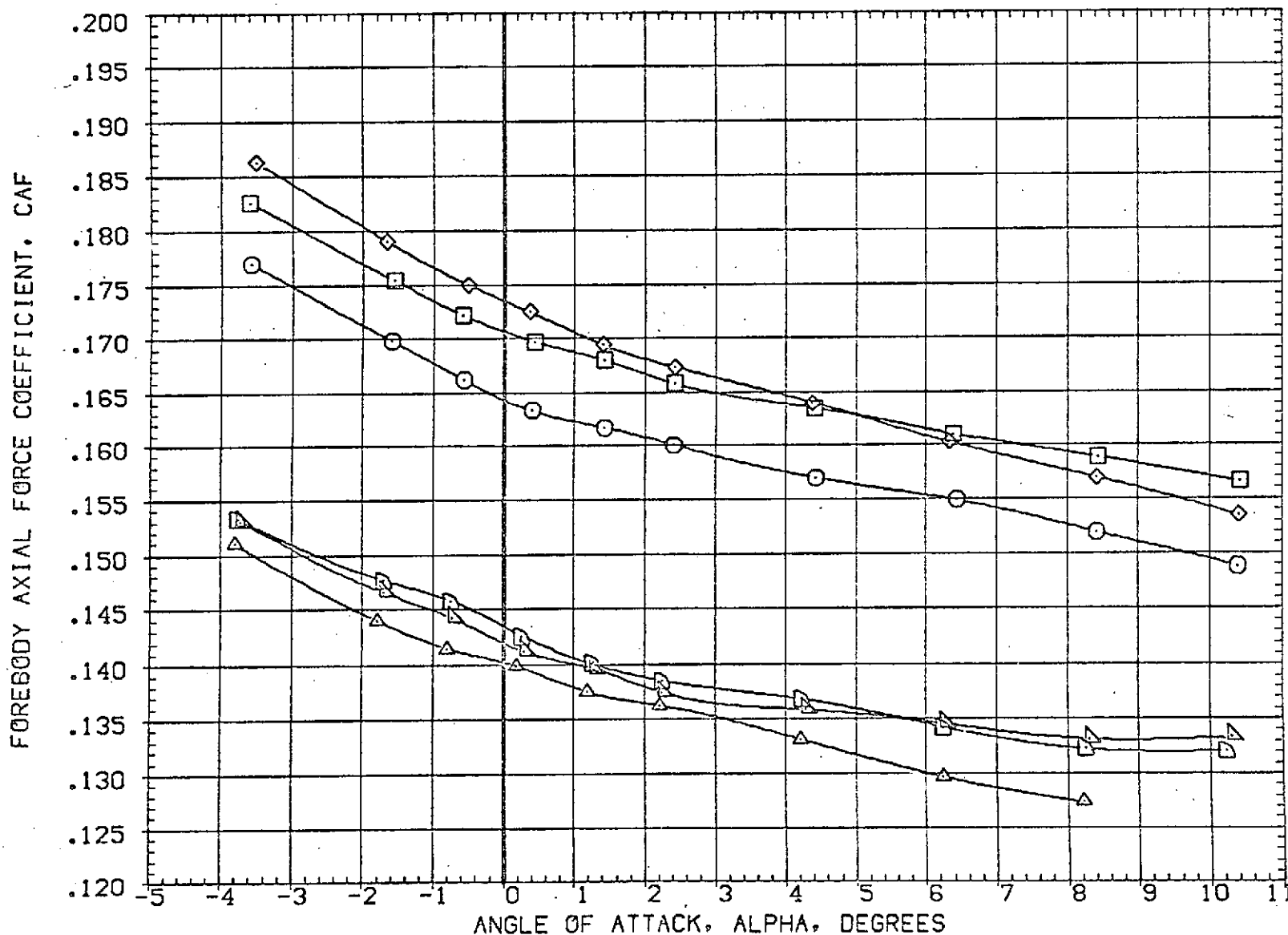

FIG 17 EFFECT OF PLUMES ON ELEVON AND RUDDER POWER, BETA=0.0

(B)MACH = 1.98

DATA SET SYMBOL	CONFIGURATION DESCRIPTION	ELEVON	AILRON	RUDDER	PLUMES	REFERENCE INFORMATION		
(RBJS01)	AMES 97-616 1A2 01 TO S1 NO PLUMES	.000	.000	.000	.000	SREF	3155.0000	SQ.FT.
(RBJS11)	AMES 97-616 1A2 01 TO S1 NO PLUMES	-10.000	.000	10.000	.000	LREF	50.8000	FT.
(RBJS21)	DATA NOT AVAILABLE	-10.000	.000	10.000	.000	BREF	73.5000	FT.
(RBJS001)	AMES 97-616 1A2 01 TO S1 PC/PT NOM. SRM A/A=8	.000	.000	.000	5.000	XMRP	86.4167	FT.
(RBJS011)	AMES 97-616 1A2 01 TO S1 PC/PT=NOM. SRM A/A=8	-10.000	.000	10.000	5.000	YMRP	.0000	FT.
(RBJS021)	DATA NOT AVAILABLE	-10.000	.000	10.000	5.000	ZMRP	4.0000	FT.
						SCALE	.0190	

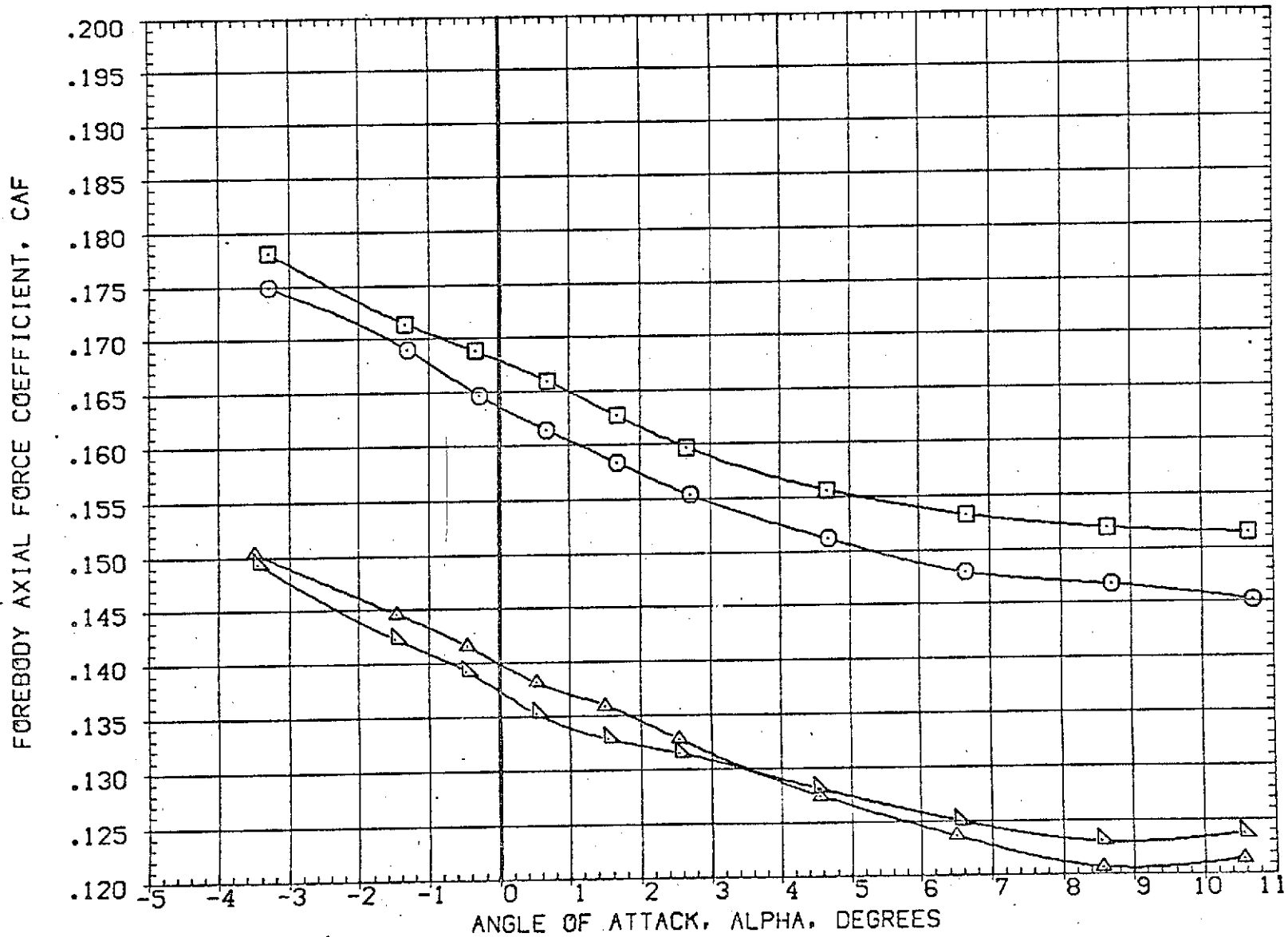

FIG 17 EFFECT OF PLUMES ON ELEVON AND RUDDER POWER, BETA=0.0
 (C)MACH = 2.17

DATA SET SYMBOL	CONFIGURATION DESCRIPTION	ELEVON	AILRON	RUDDER	PLUMES	REFERENCE INFORMATION
(RB4501)	AMES 97-616 1A2 01 TO S1 NO PLUMES	.000	.000	.000	.000	SREF 3155.0000 SQ.FT.
(RB4511)	AMES 97-616 1A2 01 TO S1 NO PLUMES	10.000	.000	10.000	.000	LREF 50.8000 FT.
(RB4521)	AMES 97-616 1A2 01 TO S1 NO PLUMES	-10.000	.000	10.000	.000	BREF 73.5000 FT.
(RB4001)	AMES 97-616 1A2 01 TO S1 PC/PT-NOM,SRM A/A=8	.000	.000	.000	5.000	XMRP 86.4167 FT.
(RB4011)	AMES 97-616 1A2 01 TO S1 PC/PT-NOM,SRM A/A=8	-10.000	.000	10.000	5.000	YMRP .0000 FT.
(RB4021)	AMES 97-616 1A2 01 TO S1 PC/PT-NOM,SRM A/A=8	-10.000	.000	10.000	5.000	ZMRP 4.0000 FT.
						SCALE .0190

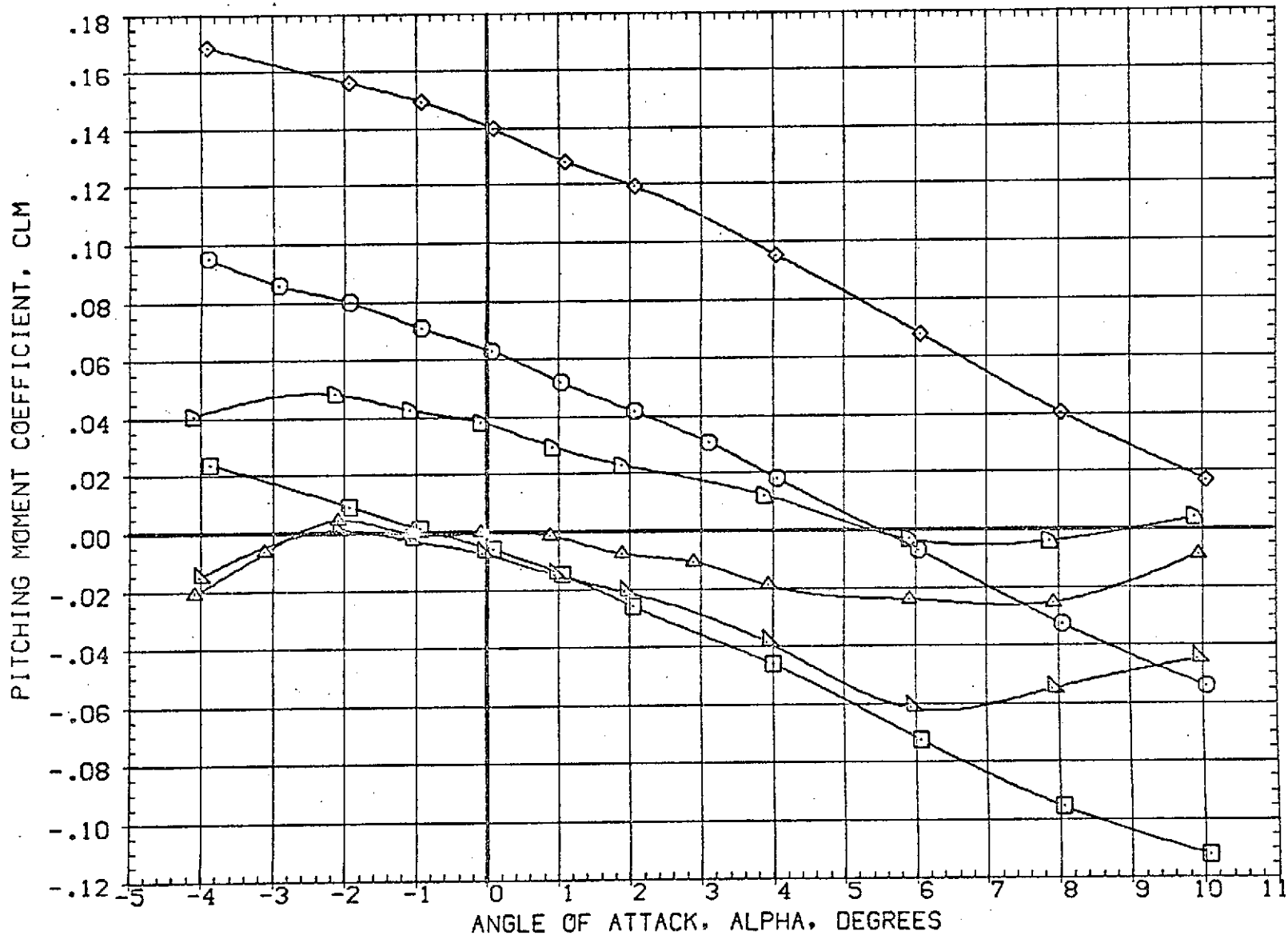

FIG 17 EFFECT OF PLUMES ON ELEVON AND RUDDER POWER, BETA=0.0

(A)MACH = 1.60

DATA SET SYMBOL	CONFIGURATION DESCRIPTION	ELEVON	AILERON	RUDDER	PLUMES	REFERENCE INFORMATION	
(RBJS01)	AMES 97-616 1A2 01 TO S1 NO PLUMES	.000	.000	.000	.000	SREF	3155.0000 SQ.FT.
(RBJS11)	AMES 97-616 1A2 01 TO S1 NO PLUMES	10.000	.000	10.000	.000	LREF	50.8000 FT.
(RBJS21)	AMES 97-616 1A2 01 TO S1 NO PLUMES	-10.000	.000	10.000	.000	BREF	73.5000 FT.
(RBJC01)	AMES 97-616 1A2 01 TO S1 PC/PT-NCM,SRM A/A=8	.000	.000	.000	5.000	XMRP	86.4167 FT.
(RBJO11)	AMES 97-616 1A2 01 TO S1 PC/PT-NCM,SRM A/A=8	10.000	.000	10.000	5.000	YMRP	.0000 FT.
(RBJO21)	AMES 97-616 1A2 01 TO S1 PC/PT-NCM,SRM A/A=8	-10.000	.000	10.000	5.000	ZMRP	4.0000 FT.
						SCALE	.0190

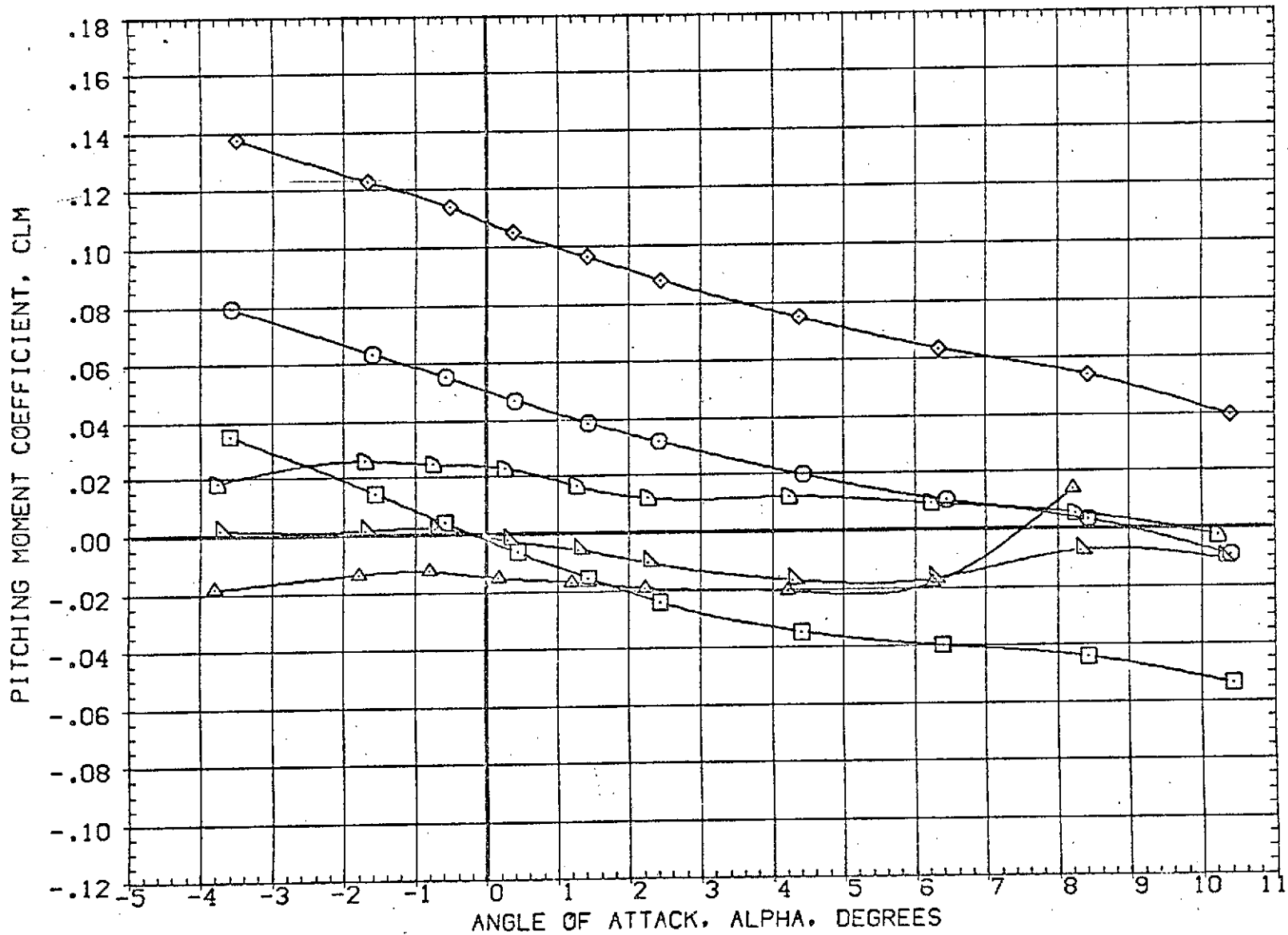

FIG 17 EFFECT OF PLUMES ON ELEVON AND RUDDER POWER, BETA=0.0

(B)MACH = 1.98

DATA SET SYMBOL	CONFIGURATION DESCRIPTION	ELEVON	AILRON	RUDDER	PLUMES	REFERENCE INFORMATION
{RBJ501}	AMES 97-616 1A2 01 TO S1 NO PLUMES	.000	.000	.000	.000	SREF 3155.0000 SQ.FT.
{RBJ511}	AMES 97-616 1A2 01 TO S1 NO PLUMES	10.000	.000	10.000	.000	LREF 50.8000 FT.
{RBJ521}	DATA NOT AVAILABLE	-10.000	.000	10.000	.000	BREF 73.5000 FT.
{RBJ001}	AMES 97-616 1A2 01 TO S1 PC/PT NOM.SRM A/A=8	.000	.000	.000	5.000	XMRP 86.4167 FT.
{RBJ011}	AMES 97-616 1A2 01 TO S1 PC/PT=NOM.SRM A/A=8	10.000	.000	10.000	5.000	YMRP .0000 FT.
{RBJ021}	DATA NOT AVAILABLE	-10.000	.000	10.000	5.000	ZMRP 4.0000 FT.
						SCALE .0190

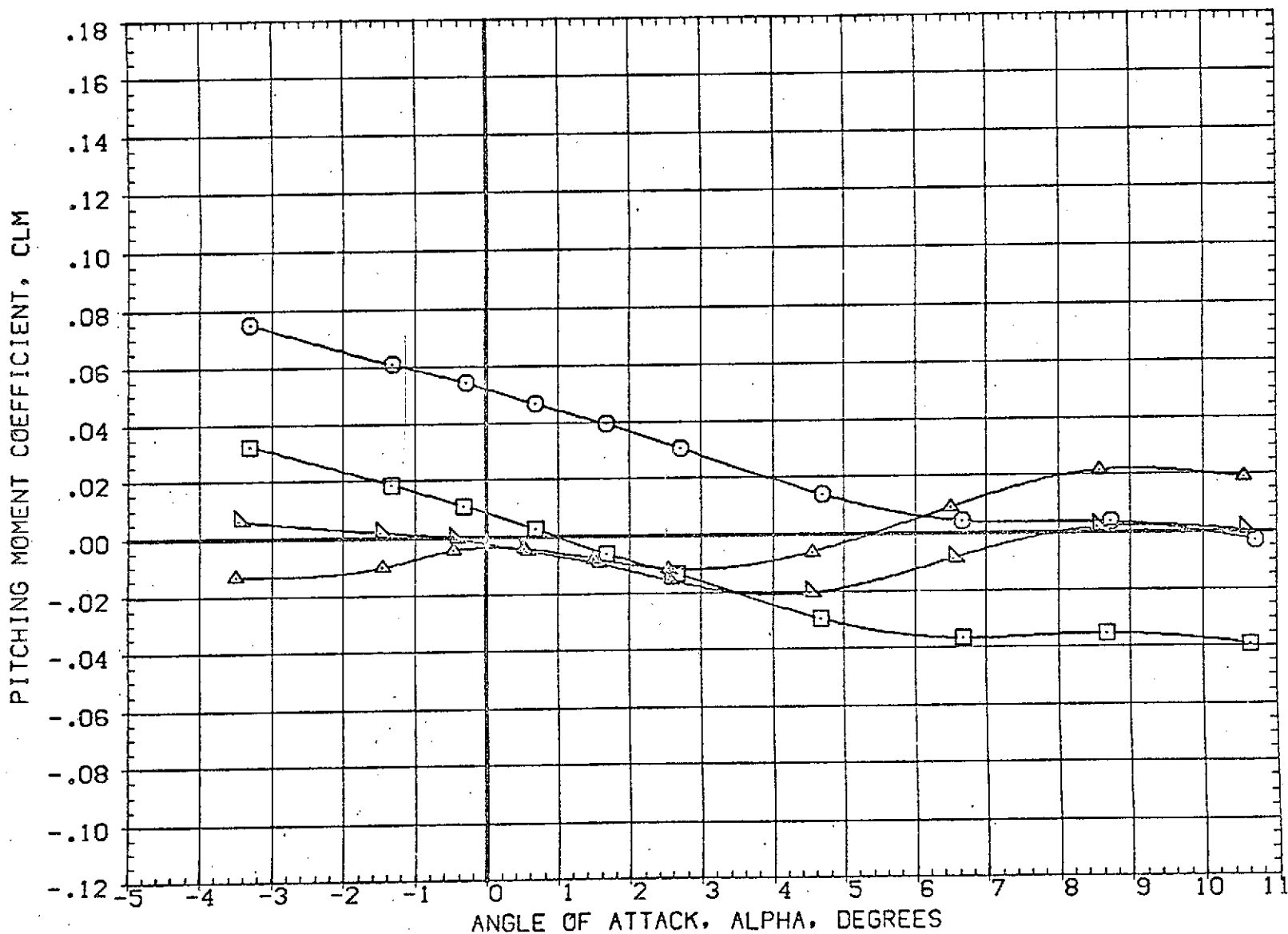

FIG 17 EFFECT OF PLUMES ON ELEVON AND RUDDER POWER, BETA=0.0

DATA SET SYMBOL	CONFIGURATION DESCRIPTION	ELEVON	AILERON	RUDDER	PLUMES	REFERENCE INFORMATION
(RBJS01)	AMES 97-616 1A2 01 TO S1 NO PLUMES	.000	.000	.000	.000	SREF 3155.0000 SQ.FT.
(RBJS11)	AMES 97-616 1A2 01 TO S1 NO PLUMES	10.000	.000	10.000	.000	LREF 50.8000 FT.
(RBJS21)	AMES 97-616 1A2 01 TO S1 NO PLUMES	-10.000	.000	10.000	.000	BREF 73.5000 FT.
(RBJS001)	AMES 97-616 1A2 01 TO S1 PC/PT-NOM,SRM A/A=8	.000	.000	.000	5.000	XMRP 86.4167 FT.
(RBJS011)	AMES 97-616 1A2 01 TO S1 PC/PT-NOM,SRM A/A=8	10.000	.000	10.000	5.000	YMRP .0000 FT.
(RBJS021)	AMES 97-616 1A2 01 TO S1 PC/PT-NOM,SRM A/A=8	-10.000	.000	10.000	5.000	ZMRP 4.0000 FT.
						SCALE .0190

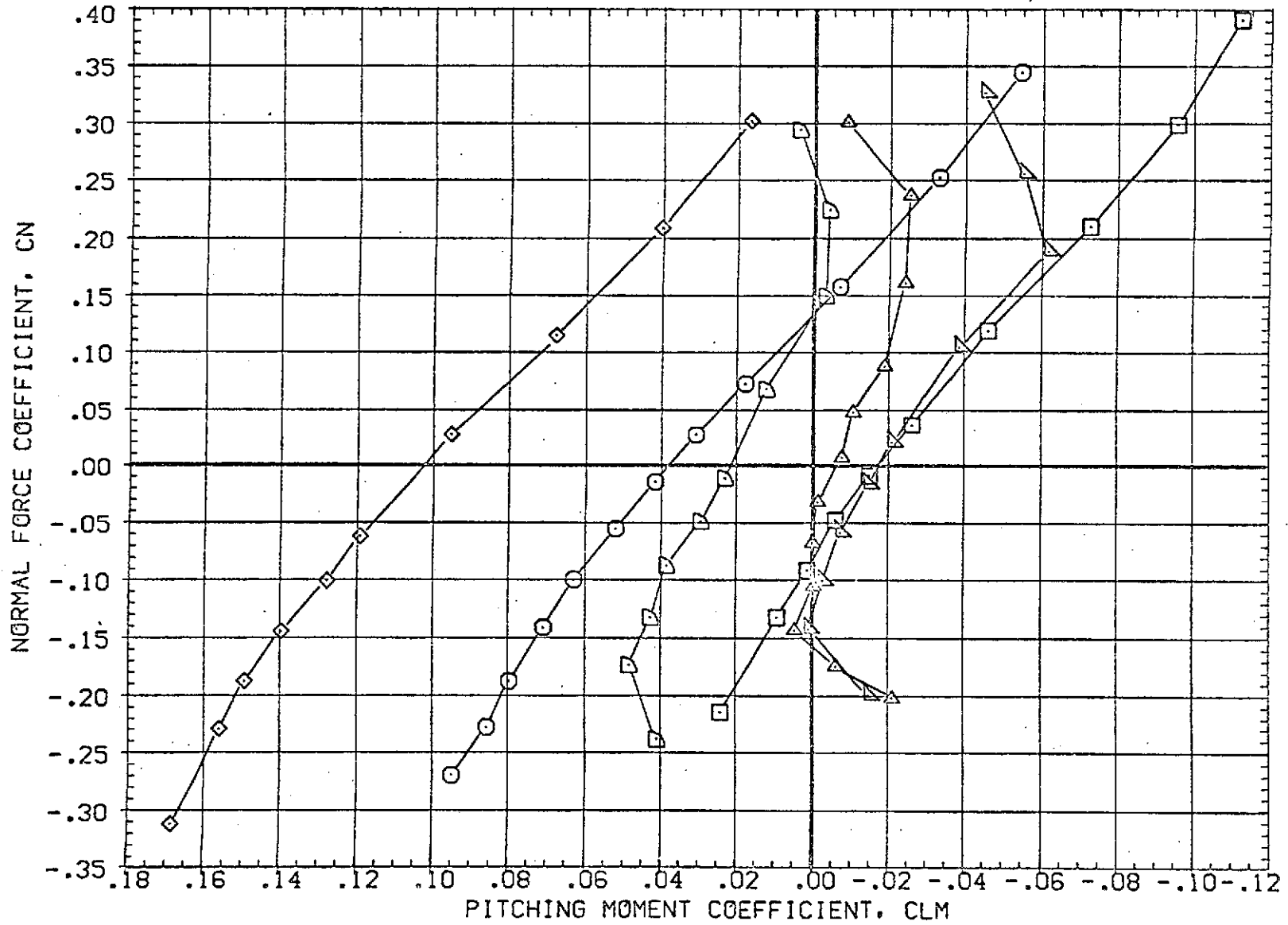

FIG 17 EFFECT OF PLUMES ON ELEVON AND RUDDER POWER, BETA=0.0

(A)MACH = 1.60

DATA SET SYMBOL	CONFIGURATION DESCRIPTION	ELEVON	AILERON	RUDDER	PLUMES	REFERENCE INFORMATION
(RBJS01)	AMES 97-616 1A2 01 TO S1 NO PLUMES	.000	.000	.000	.000	SREF 3155.0000 SQ.FT.
(RBJS11)	AMES 97-616 1A2 01 TO S1 NO PLUMES	10.000	.000	10.000	.000	LREF 50.8000 FT.
(RBJS21)	AMES 97-616 1A2 01 TO S1 NO PLUMES	-10.000	.000	10.000	.000	BREF 73.5000 FT.
(RBJ001)	AMES 97-616 1A2 01 TO S1 PC/PT NOM, SRM A/A=8	.000	.000	.000	5.000	XMRP 86.4167 FT.
(RBJ011)	AMES 97-616 1A2 01 TO S1 PC/PT=NOM, SRM A/A=8	10.000	.000	10.000	5.000	YMRP .0000 FT.
(RBJ021)	AMES 97-616 1A2 01 TO S1 PC/PT=NOM SRM A/A=8	-10.000	.000	10.000	5.000	ZMRP 4.0000 FT.
						SCALE .0190

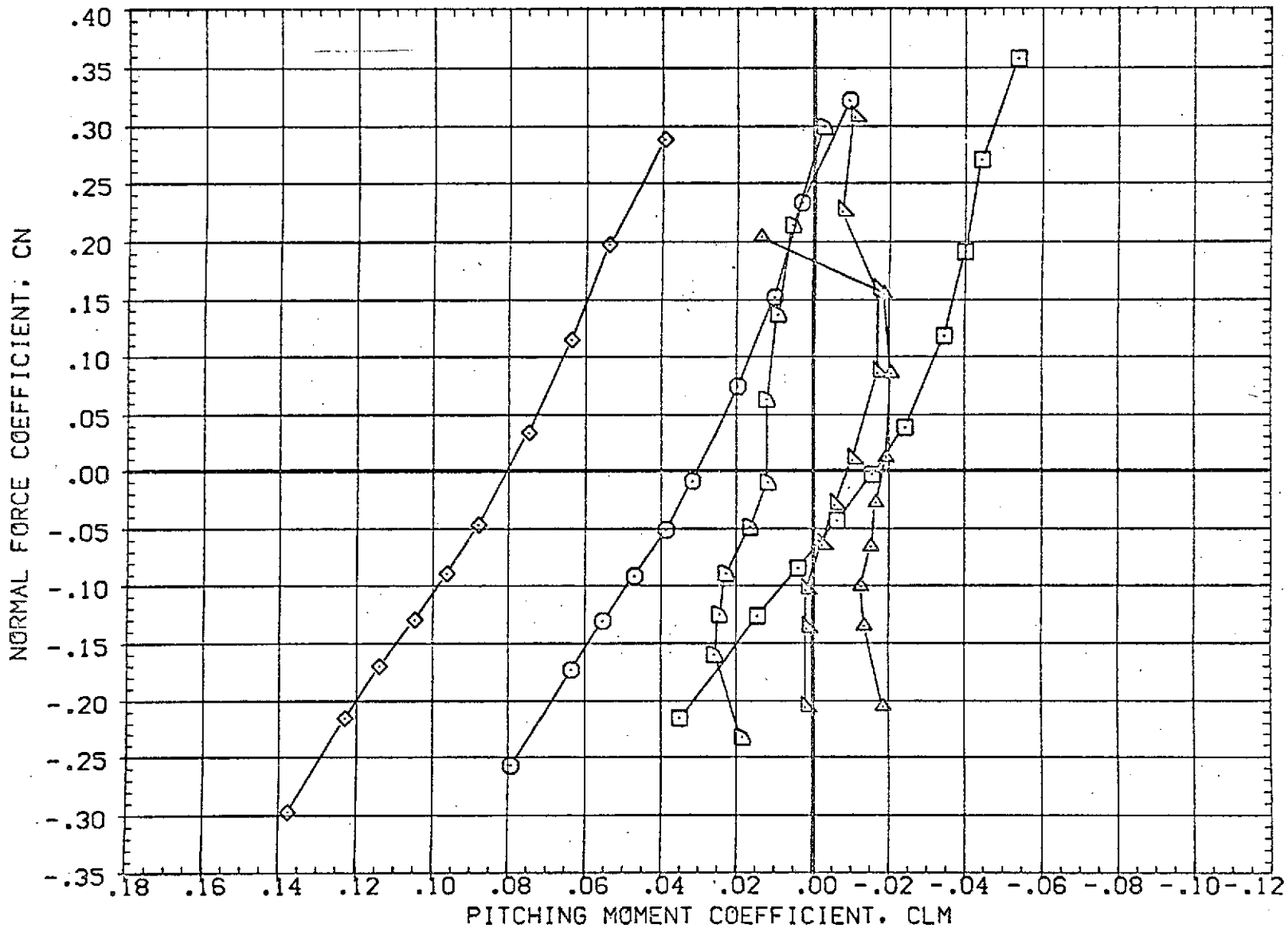

FIG 17 EFFECT OF PLUMES ON ELEVON AND RUDDER POWER, BETA=0.0

DATA SET SYMBOL	CONFIGURATION DESCRIPTION	ELEVON	AILRON	RUDDER	PLUMES	REFERENCE INFORMATION
(RBJ501)	AMES 97-616 IA2 01 TO S1 NO PLUMES	.000	.000	.000	.000	SREF 3155.0000 SQ.FT.
(RBJ511)	AMES 97-616 IA2 01 TO S1 NO PLUMES	10.000	.000	10.000	.000	LREF 50.8000 FT.
(RBJ521)	DATA NOT AVAILABLE	-10.000	.000	10.000	.000	BREF 73.5000 FT.
(RBJ001)	AMES 97-616 IA2 01 TO S1 PC/PT NOM.SRM A/A=8	.000	.000	.000	5.000	XMRP 85.4167 FT.
(RBJ011)	AMES 97-616 IA2 01 TO S1 PC/PT=NOM.SRM A/A=8	10.000	.000	10.000	5.000	YMRP .0000 FT.
(RBJ021)	DATA NOT AVAILABLE	-10.000	.000	10.000	5.000	ZMRP 4.0000 FT.
						SCALE .0190

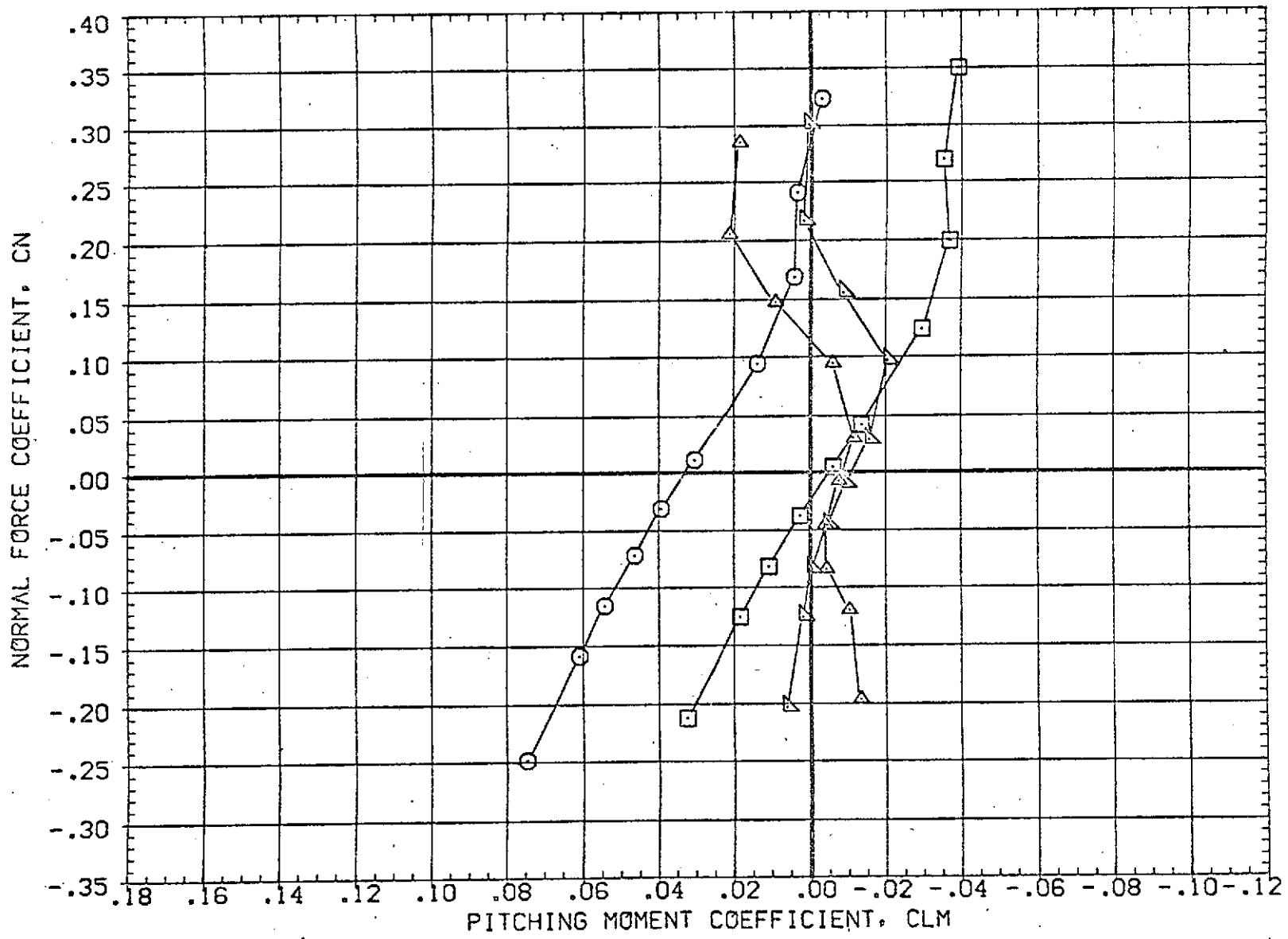

FIG 17 EFFECT OF PLUMES ON ELEVON AND RUDDER POWER, BETA=0.0

(C)MACH = 2.17

DATA SET SYMBOL	CONFIGURATION DESCRIPTION	ELEVON	AILRON	RUDDER	PLUMES	REFERENCE INFORMATION
(RBW501)	AMES 97-616 1A2 01 TO S1 NO PLUMES	.000	.000	.000	.000	SREF 3155.0000 SQ.FT.
(RBW511)	AMES 97-616 1A2 01 TO S1 NO PLUMES	10.000	.000	10.000	.000	LREF 50.8000 FT.
(RBW521)	AMES 97-616 1A2 01 TO S1 NO PLUMES	-10.000	.000	10.000	.000	BREF 73.5000 FT.
(RBW001)	AMES 97-616 1A2 01 TO S1 PC/PT-NOM, SRM A/A=8	.000	.000	.000	5.000	XMRP 86.4167 FT.
(RBW011)	AMES 97-616 1A2 01 TO S1 PC/PT-NOM, SRM A/A=8	-10.000	.000	10.000	5.000	YMRP .0000 FT.
(RBW021)	AMES 97-616 1A2 01 TO S1 PC/PT-NOM, SRM A/A=8	-10.000	.000	10.000	5.000	ZMRP 4.0000 FT.
						SCALE .0190

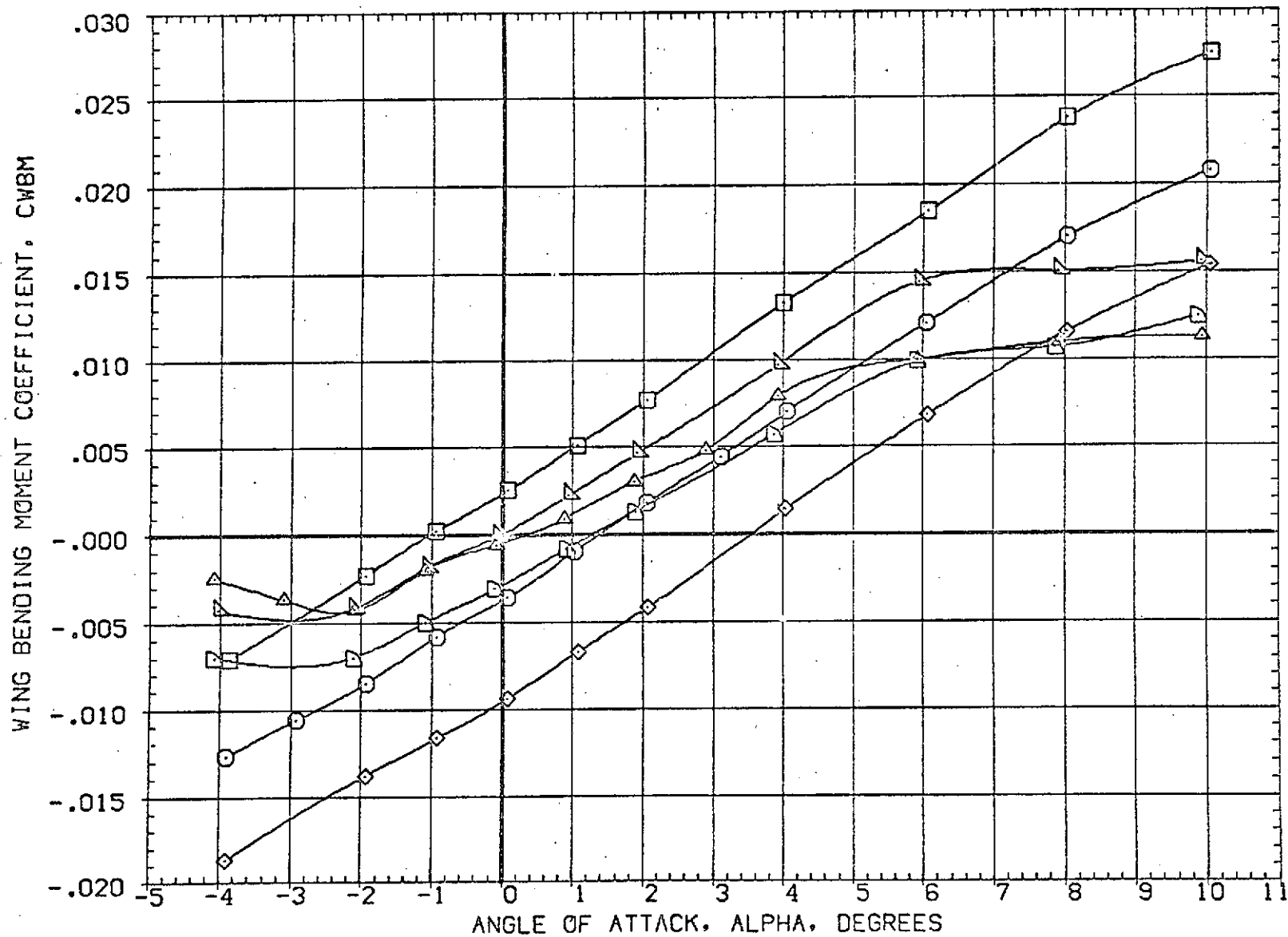

FIG 17 EFFECT OF PLUMES ON ELEVON AND RUDDER POWER, BETA=0.0

DATA SET SYMBOL	CONFIGURATION DESCRIPTION	ELEVON	AILERON	RUDDER	PLUMES	REFERENCE INFORMATION
(RBJ501)	AMES 97-616 1A2 01 TO S1 NO PLUMES	.000	.000	.000	.000	SREF 3155.0000 SQ.FT.
(RBJ511)	AMES 97-616 1A2 01 TO S1 NO PLUMES	10.000	.000	10.000	.000	LREF 50.8000 FT.
(RBJ521)	AMES 97-616 1A2 01 TO S1 NO PLUMES	-10.000	.000	10.000	.000	BREF 73.5000 FT.
(RBJ001)	AMES 97-616 1A2 01 TO S1 PC/PT-NOM, SRM A/A=8	.000	.000	.000	5.000	XMRP 86.4167 FT.
(RBJ011)	AMES 97-616 1A2 01 TO S1 PC/PT-NOM, SRM A/A=8	-10.000	.000	10.000	5.000	YMRP .0000 FT.
(RBJ021)	AMES 97-616 1A2 01 TO S1 PC/PT-NOM SRM A/A=8	-10.000	.000	10.000	5.000	ZMRP 4.0000 FT.
						SCALE .0190

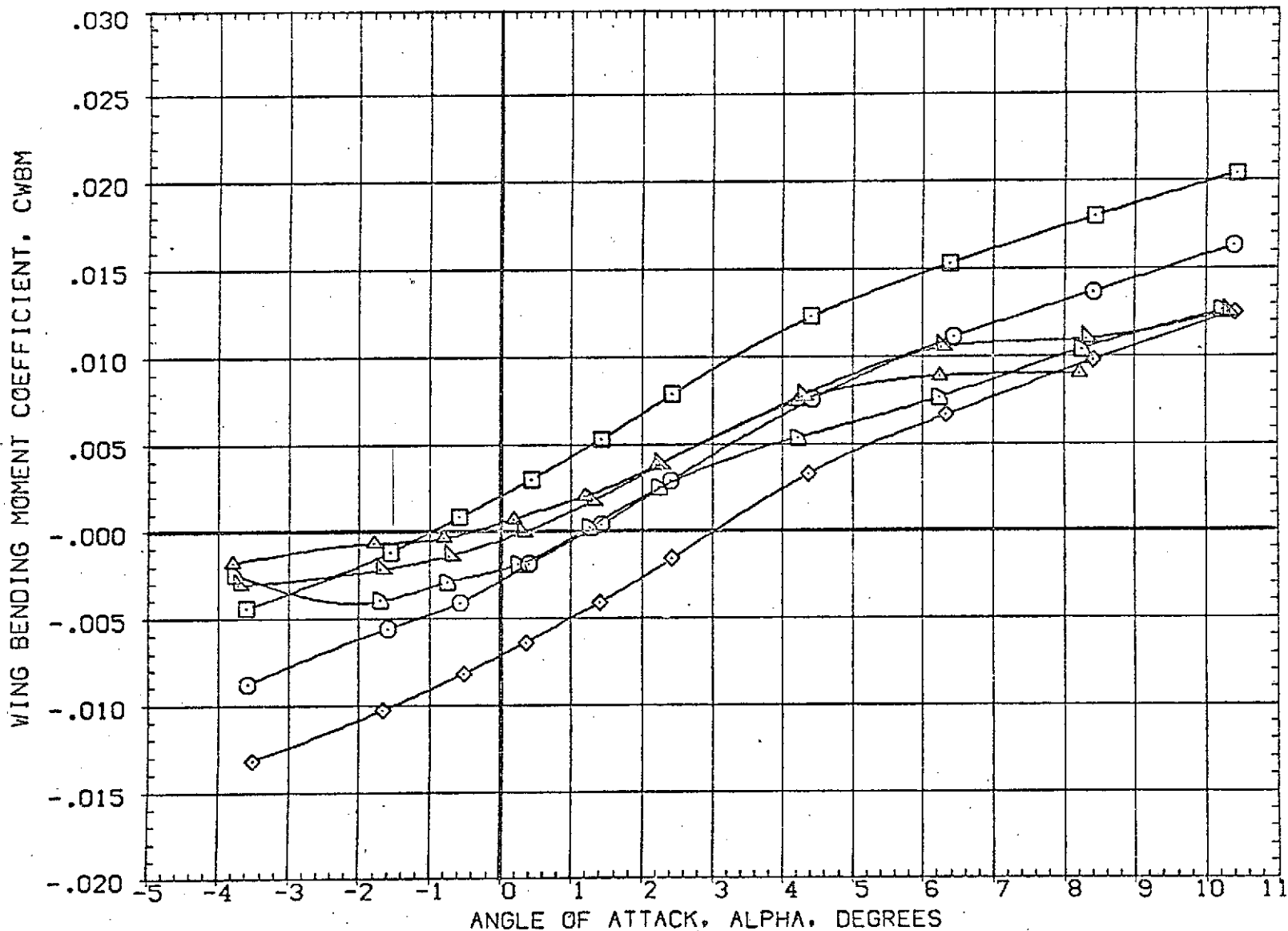

FIG 17 EFFECT OF PLUMES ON ELEVON AND RUDDER POWER, BETA=0.0

(8)MACH = 1.98

DATA SET SYMBOL	CONFIGURATION DESCRIPTION	ELEVON	AILRON	RUDDER	PLUMES	REFERENCE INFORMATION	
(RBJ501)	AMES 97-616 1A2 01 TO S1 NO PLUMES	.000	.000	.000	.000	SREF	3155.0000 SQ.FT.
(RBJ511)	AMES 97-616 1A2 01 TO S1 NO PLUMES	10.000	.000	10.000	.000	LREF	50.8000 FT.
(RBJ521)	DATA NOT AVAILABLE	-10.000	.000	10.000	.000	BREF	73.5000 FT.
(RBJ001)	AMES 97-616 1A2 01 TO S1 PC/PT NOM, SRM A/A=8	.000	.000	.000	5.000	XMRP	86.4167 FT.
(RBJ011)	AMES 97-616 1A2 01 TO S1 PC/PT=NOM, SRM A/A=8	10.000	.000	10.000	5.000	YMRP	.0000 FT.
(RBJ021)	DATA NOT AVAILABLE	-10.000	.000	10.000	5.000	ZMRP	4.0000 FT.
						SCALE	.0190

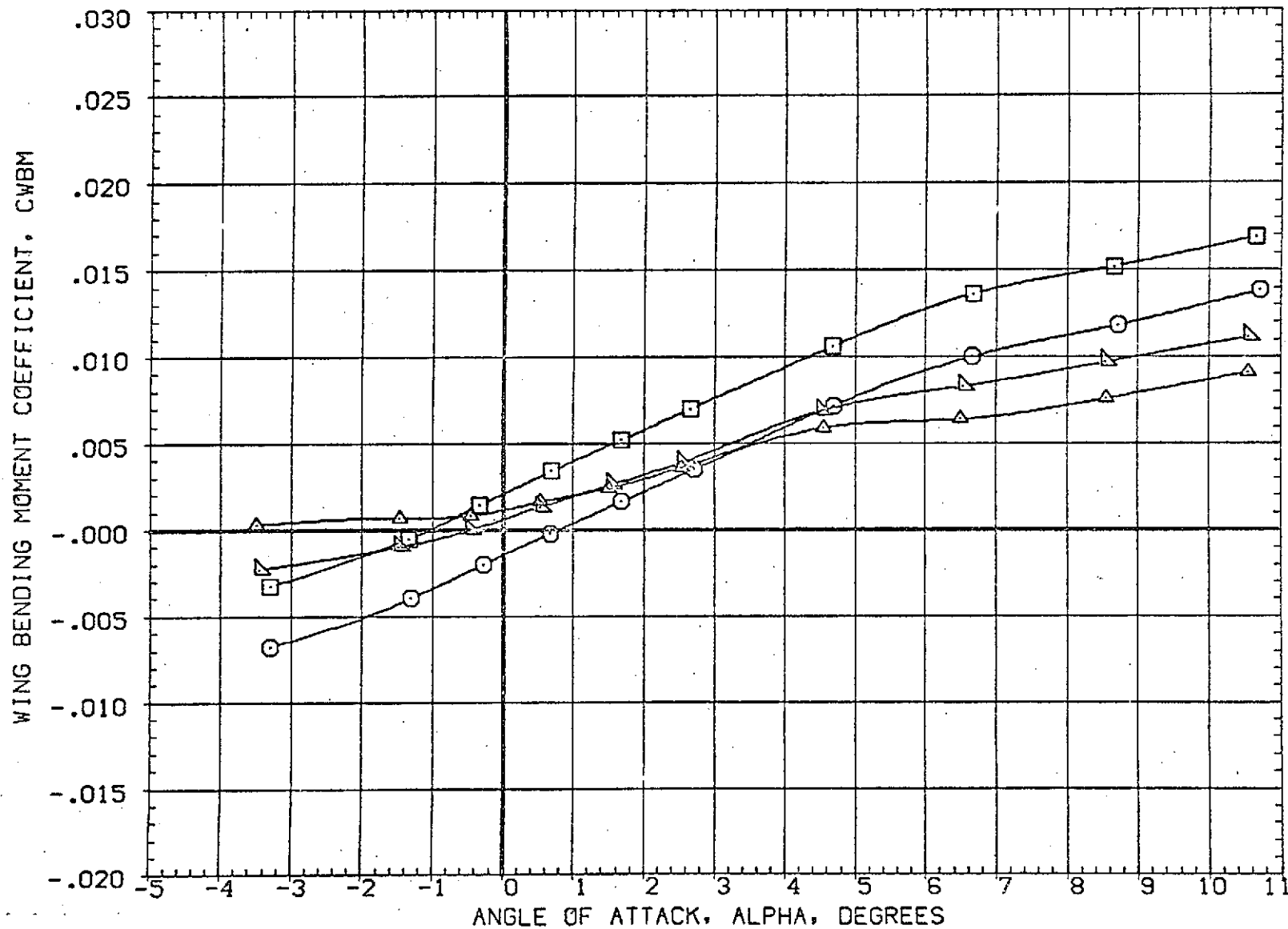

FIG 17 EFFECT OF PLUMES ON ELEVON AND RUDDER POWER, BETA=0.0

(C)MACH = 2.17

DATA SET SYMBOL	CONFIGURATION DESCRIPTION	ELEVON	AILERON	RUDDER	PLUMES	REFERENCE INFORMATION		
(RBJ501)	AMES 97-616 IA2 01 TO S1 NO PLUMES	.000	.000	.000	.000	SREF	3155.0000	SQ.FT.
(RBJ511)	AMES 97-616 IA2 01 TO S1 NO PLUMES	10.000	.000	10.000	.000	LREF	50.8000	FT.
(RBJ521)	AMES 97-616 IA2 01 TO S1 NO PLUMES	-10.000	.000	10.000	.000	BREF	73.5000	FT.
(RBJ001)	AMES 97-616 IA2 01 TO S1 PC/PT=NOM.SRM A/A=8	.000	.000	.000	5.000	XMRP	85.4167	FT.
(RBJ011)	AMES 97-616 IA2 01 TO S1 PC/PT=NOM.SRM A/A=8	10.000	.000	10.000	5.000	YMRP	.0000	FT.
(RBJ021)	AMES 97-616 IA2 01 TO S1 PC/PT=NOM.SRM A/A=8	-10.000	.000	10.000	5.000	ZMRP	4.0000	FT.
						SCALE	.0190	

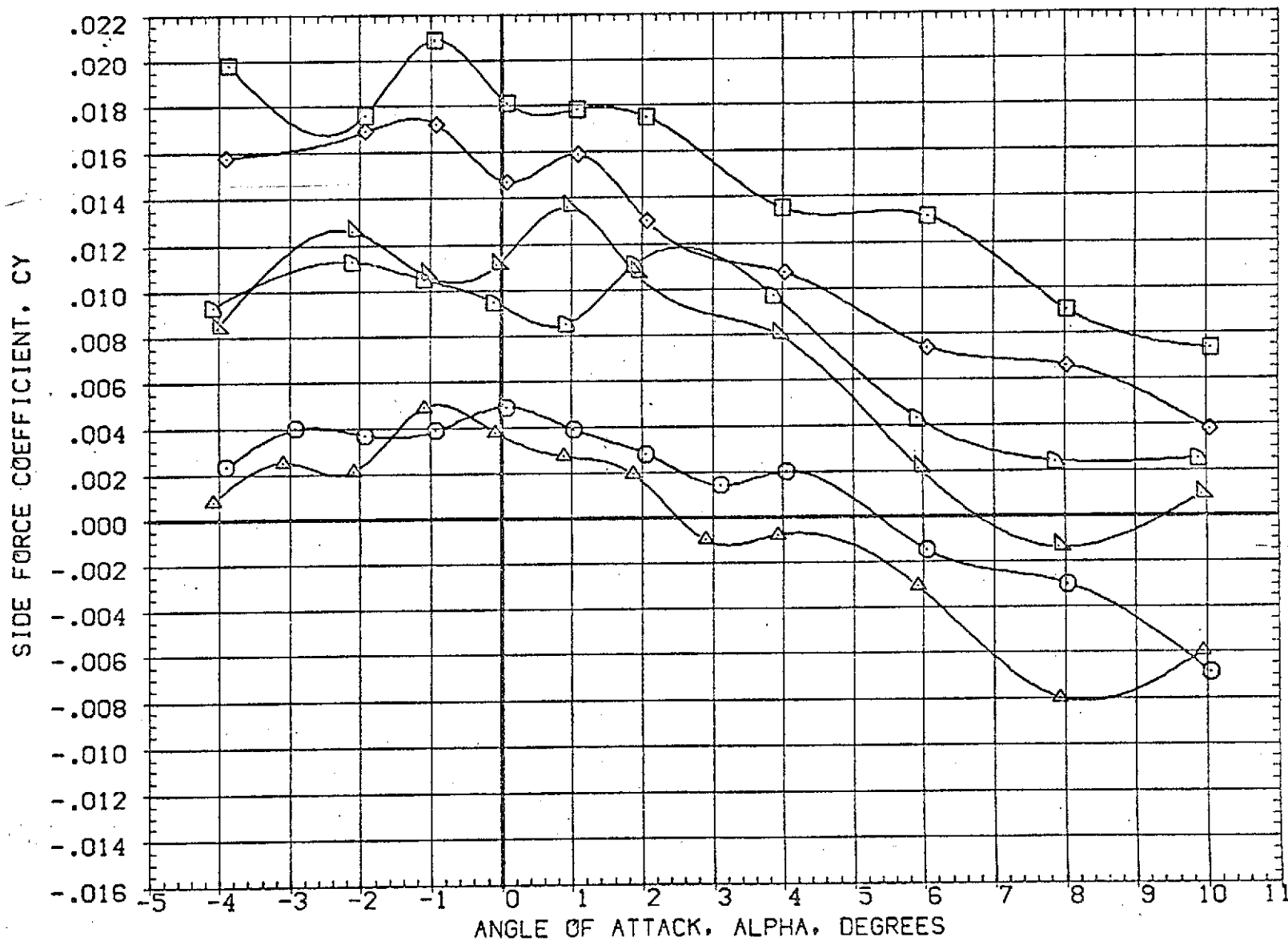

FIG 17 EFFECT OF PLUMES ON ELEVON AND RUDDER POWER, BETA=0.0

(A)MACH = 1.60

Page intentionally left blank

DATA SET SYMBOL	CONFIGURATION DESCRIPTION	ELEVON	AILERON	RUDDER	PLUMES	REFERENCE INFORMATION
(R0501)	AMES 97-616 IA2 01 TO S1 NO PLUMES	.000	.000	.000	.000	SREF 3155.0000 SO.FT.
(R0511)	AMES 97-616 IA2 01 TO S1 NO PLUMES	10.000	.000	10.000	.000	LREF 50.8000 FT.
(R0521)	DATA NOT AVAILABLE	-10.000	.000	10.000	.000	BREF 73.5000 FT.
(R0001)	AMES 97-616 IA2 01 TO S1 PC/PT NOM. SRM A/A=8	.000	.000	.000	5.000	XMRP 66.4167 FT.
(R0011)	AMES 97-616 IA2 01 TO S1 PC/PT-NOM. SRM A/A=8	10.000	.000	10.000	5.000	YMRP .0000 FT.
(R0021)	DATA NOT AVAILABLE	-10.000	.000	10.000	5.000	ZMRP 4.0000 FT.
						SCALE .0150

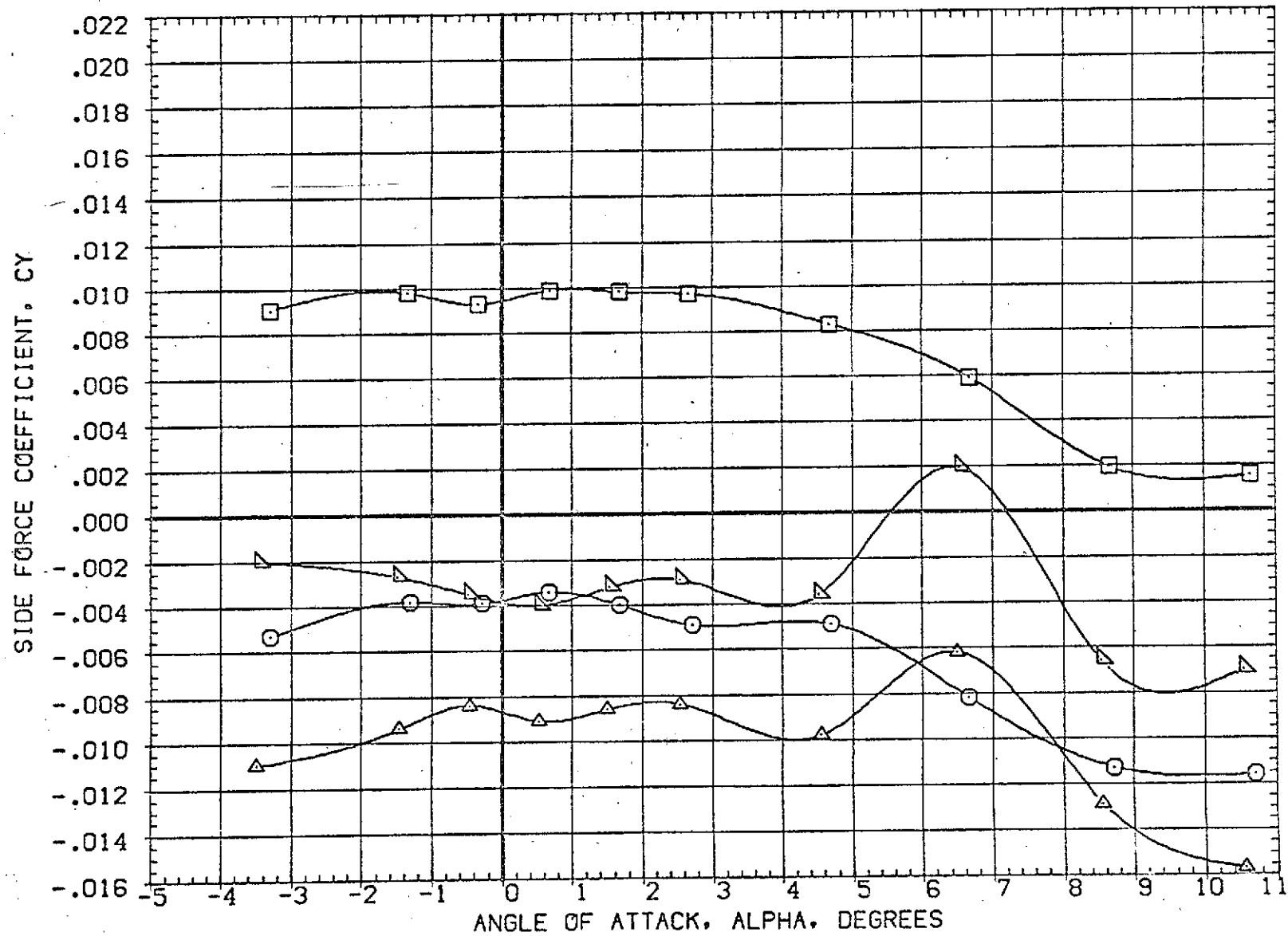

FIG 17 EFFECT OF PLUMES ON ELEVON AND RUDDER POWER, BETA=0.0

(C)MACH = 2.17

DATA SET SYMBOL	CONFIGURATION DESCRIPTION	ELEVON	AILRON	RUDDER	PLUMES	REFERENCE INFORMATION
(RBJ501)	AMES 97-616 1A2 01 TO S1 NO PLUMES	.000	.000	.000	.000	SREF 3155.0000 SQ.FT.
(RBJ511)	AMES 97-616 1A2 01 TO S1 NO PLUMES	10.000	.000	10.000	.000	LREF 50.8000 FT.
(RBJ521)	AMES 97-616 1A2 01 TO S1 NO PLUMES	-10.000	.000	10.000	.000	BREF 73.5000 FT.
(RBJ001)	AMES 97-616 1A2 01 TO S1 PC/PT NCM, SRM A/A=8	.000	.000	.000	5.000	XMRP 86.4167 FT.
(RBJ011)	AMES 97-616 1A2 01 TO S1 PC/PT=NCM, SRM A/A=8	10.000	.000	10.000	5.000	YMRP .0000 FT.
(RBJ021)	AMES 97-616 1A2 01 TO S1 PC/PT=NCM SRM A/A=8	-10.000	.000	10.000	5.000	ZMRP 4.0000 FT.
						SCALE .0190

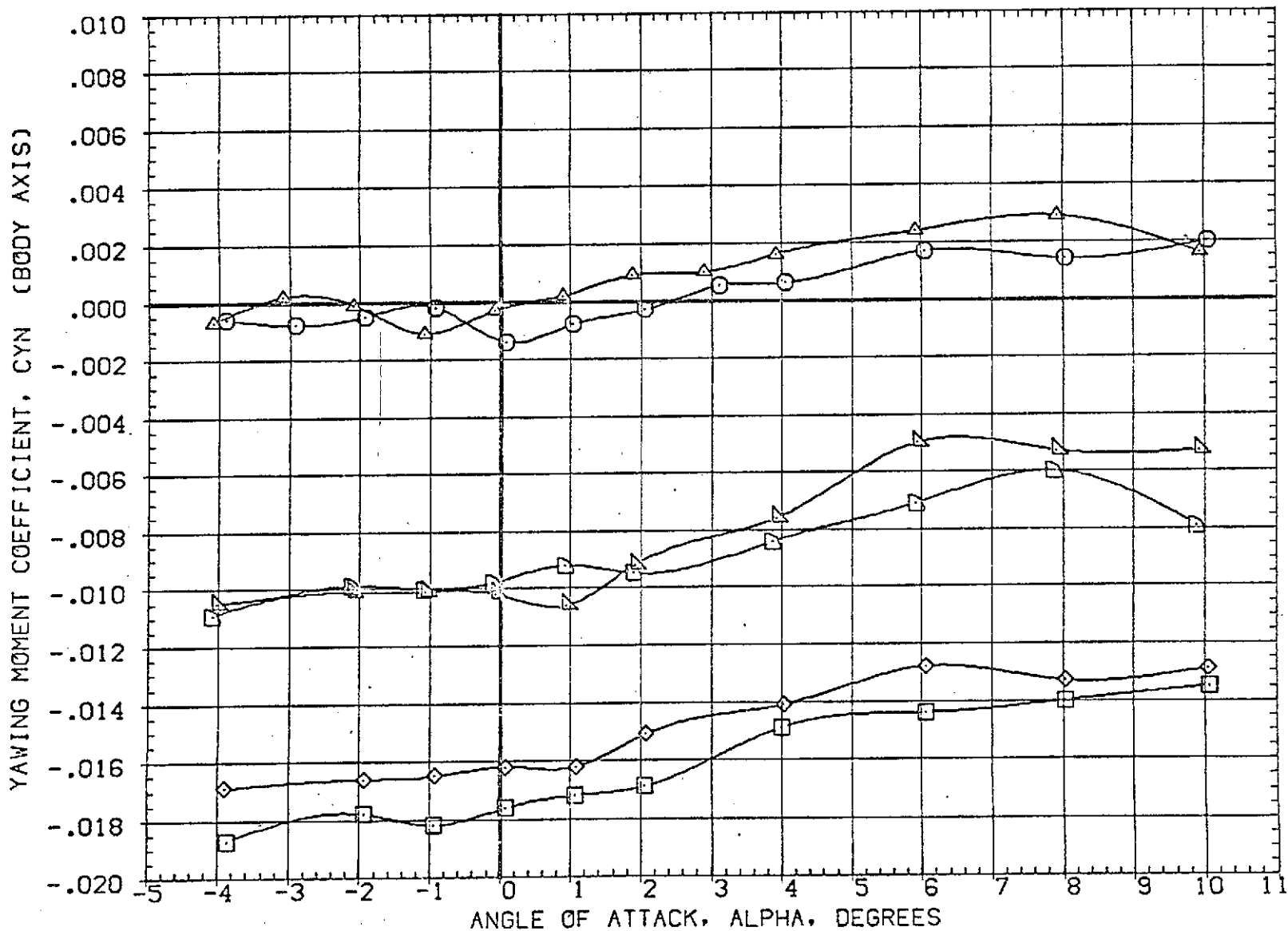

FIG 17 EFFECT OF PLUMES ON ELEVON AND RUDDER POWER, BETA=0.0

(A)MACH = 1.60

DATA SET SYMBOL	CONFIGURATION DESCRIPTION	ELEVON	AILRON	RUDDER	PLUMES	REFERENCE INFORMATION		
(RBJ501)	AMES 97-616 1A2 01 TO S1 NO PLUMES	.000	.000	.000	.000	SREF	3155.0000	50.FT.
(RBJ511)	AMES 97-616 1A2 01 TO S1 NO PLUMES	-10.000	.000	10.000	.000	LREF	50.8000	FT.
(RBJ521)	AMES 97-616 1A2 01 TO S1 NO PLUMES	-10.000	.000	10.000	.000	BREF	73.5000	FT.
(RBJ001)	AMES 97-616 1A2 01 TO S1 PC/PT=NOM,SRM A/A=8	.000	.000	.000	5.000	XMRP	86.4167	FT.
(RBJ011)	AMES 97-616 1A2 01 TO S1 PC/PT=NOM,SRM A/A=8	-10.000	.000	10.000	5.000	YMRP	.0000	FT.
(RBJ021)	AMES 97-616 1A2 01 TO S1 PC/PT=NOM,SRM A/A=8	-10.000	.000	10.000	5.000	ZMRP	4.0000	FT.
						SCALE	.0190	

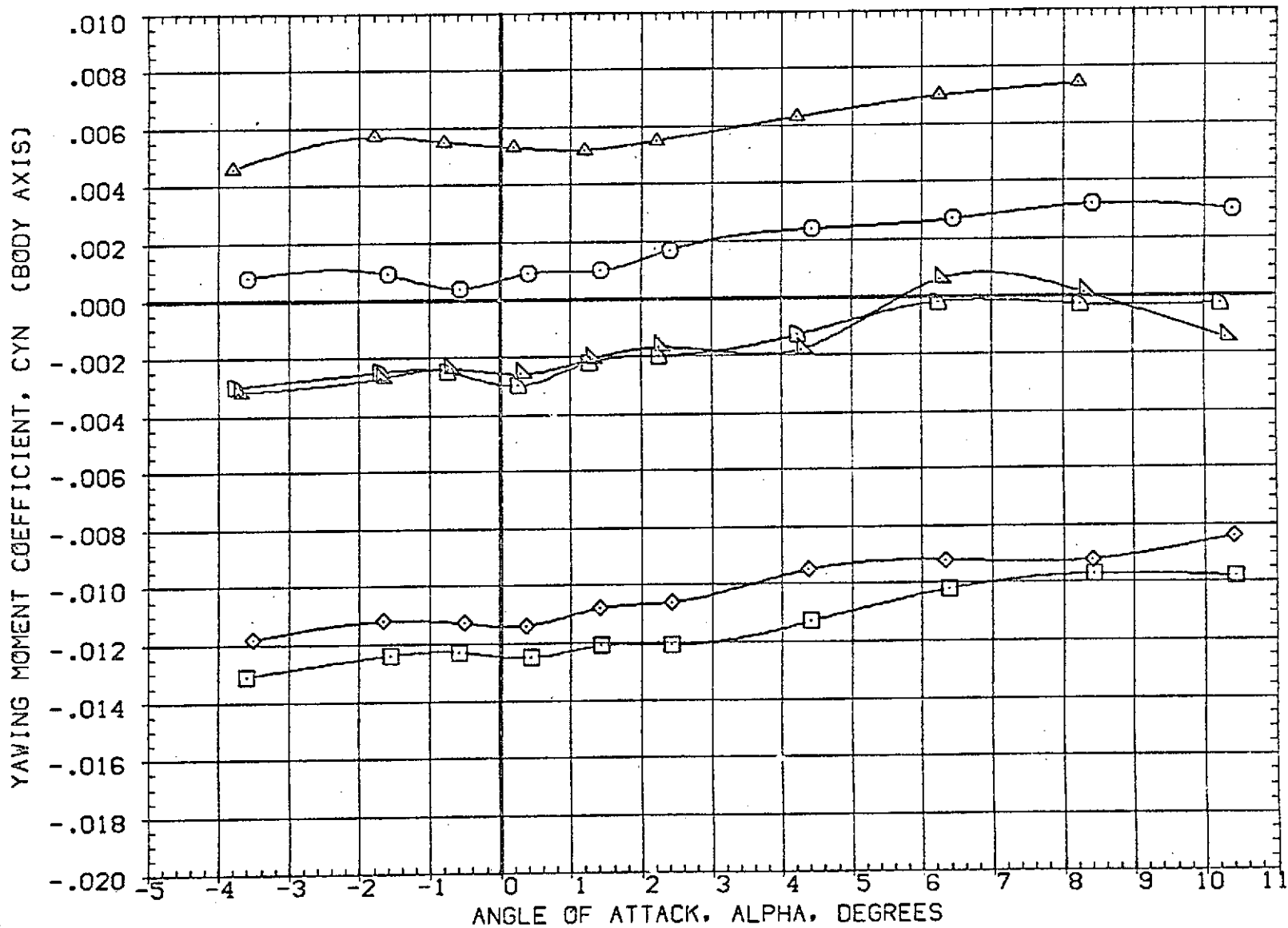

FIG 17 EFFECT OF PLUMES ON ELEVON AND RUDDER POWER, BETA=0.0

(B)MACH = 1.98

DATA SET SYMBOL	CONFIGURATION DESCRIPTION	ELEVON	AILERON	RUDDER	PLUMES	REFERENCE INFORMATION	
(RBJ501)	AMES 97-616 1A2 01 TO S1 NO PLUMES	.000	.000	.000	.000	SREF	3155.0000 50.FT.
(RBJ511)	AMES 97-616 1A2 01 TO S1 NO PLUMES	10.000	.000	10.000	.000	LREF	50.8000 FT.
(RBJ521)	DATA NOT AVAILABLE	-10.000	.000	10.000	.000	BREF	73.5000 FT.
(RBJ001)	AMES 97-616 1A2 01 TO S1 PC/PT-NOM.SRM A/A=8	.000	.000	.000	5.000	XMRP	86.4167 FT.
(RBJ011)	AMES 97-616 1A2 01 TO S1 PC/PT-NOM.SRM A/A=8	10.000	.000	10.000	5.000	YMRP	.0000 FT.
(RBJ021)	DATA NOT AVAILABLE	-10.000	.000	10.000	5.000	ZMRP	4.0000 FT.
						SCALE	.0190

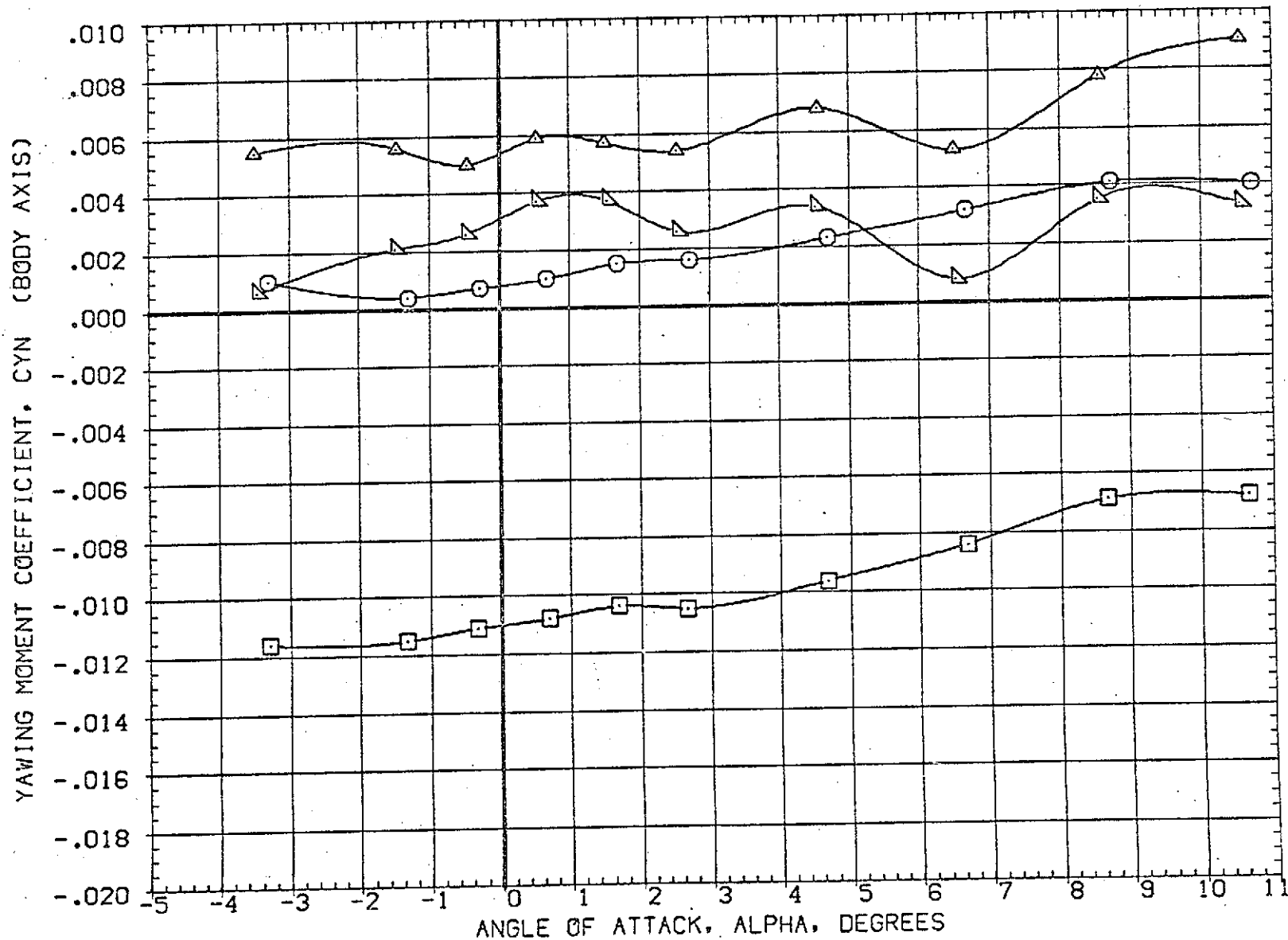

FIG 17 EFFECT OF PLUMES ON ELEVON AND RUDDER POWER, BETA=0.0

(C)MACH = 2.17

DATA SET SYMBOL	CONFIGURATION DESCRIPTION	ELEVON	AILRON	RUDDER	PLUMES	REFERENCE INFORMATION
(R2J501)	AMES 97-616 1A2 01 TO S1 NO PLUMES	.000	.000	.000	.000	SREF 3155.0000 SQ.FT.
(R2J511)	AMES 97-616 1A2 01 TO S1 NO PLUMES	10.000	.000	10.000	.000	LREF 50.8000 FT.
(R3J521)	AMES 97-616 1A2 01 TO S1 NO PLUMES	-10.000	.000	10.000	.000	SREF 73.5000 FT.
(R3J001)	AMES 97-616 1A2 01 TO S1 PC/PT-NOM, SRM A/A=8	.000	.000	.000	5.000	XMRP 86.4167 FT.
(R3J011)	AMES 97-616 1A2 01 TO S1 PC/PT-NOM, SRM A/A=8	10.000	.000	10.000	5.000	YMRP .0000 FT.
(R3J021)	AMES 97-616 1A2 01 TO S1 PC/PT-NOM, SRM A/A=8	-10.000	.000	10.000	5.000	ZMRP 4.0000 FT.
						SCALE .0190

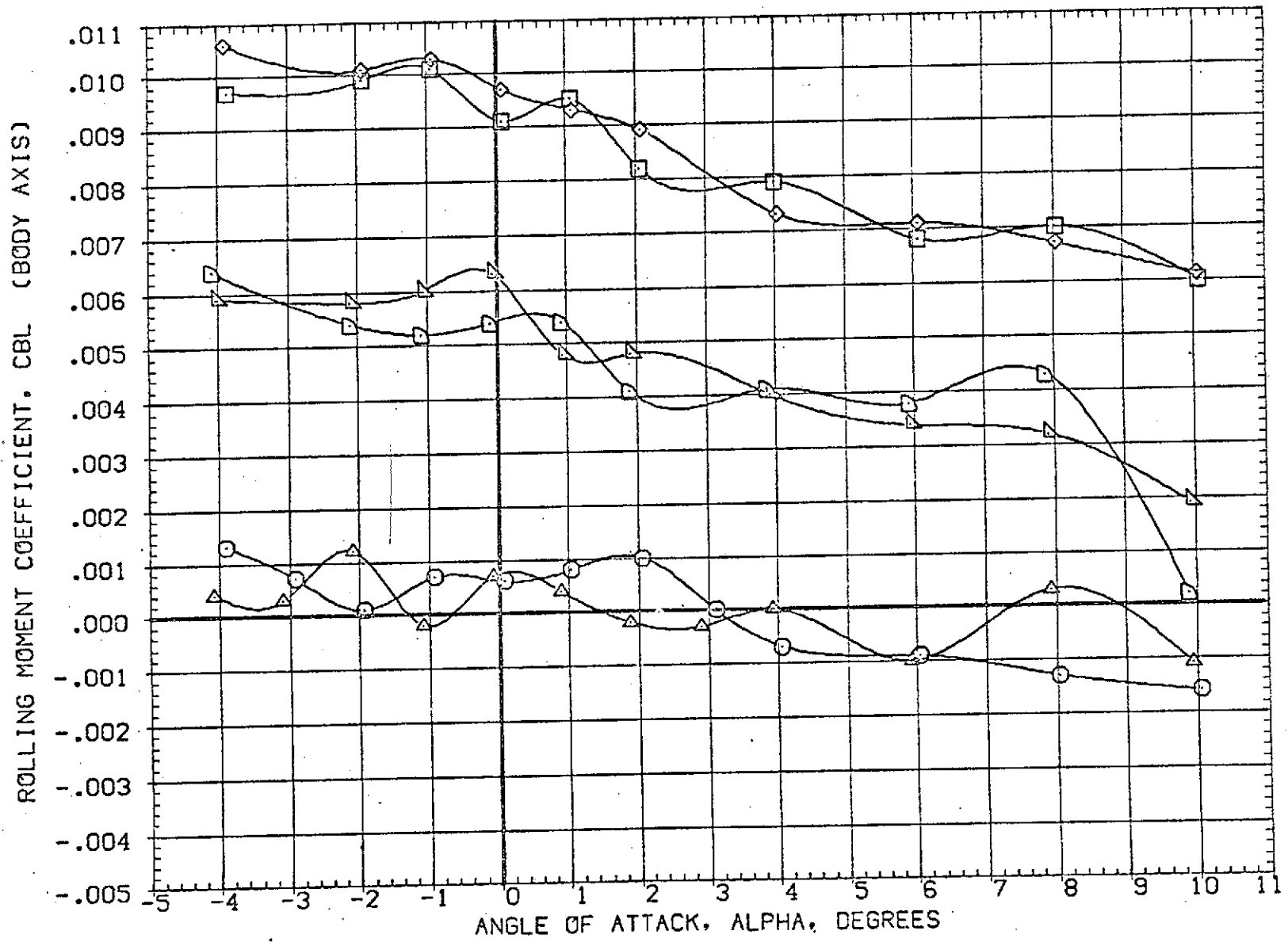

FIG 17 EFFECT OF PLUMES ON ELEVON AND RUDDER POWER, BETA=0.0

(A)MACH = 1.60

DATA SET SYMBOL	CONFIGURATION DESCRIPTION	ELEVON	AILRON	RUDDER	PLUMES	REFERENCE INFORMATION
(RBJ501)	AMES 97-616 IA2 01 TO S1 NO PLUMES	.000	.000	.000	.000	SREF 3155.0000 SQ.FT.
(RBJ511)	AMES 97-616 IA2 01 TO S1 NO PLUMES	10.000	.000	10.000	.000	LREF 50.8000 FT.
(RBJ521)	AMES 97-616 IA2 01 TO S1 NO PLUMES	-10.000	.000	10.000	.000	BREF 73.5000 FT.
(RBJ001)	AMES 97-616 IA2 01 TO S1 PC/PT=NGM SRM A/A=8	.000	.000	.000	5.000	XMRP 86.4167 FT.
(RBJ011)	AMES 97-616 IA2 01 TO S1 PC/PT=NGM SRM A/A=8	10.000	.000	10.000	5.000	YMRP .0000 FT.
(RBJ021)	AMES 97-616 IA2 01 TO S1 PC/PT=NGM SRM A/A=8	-10.000	.000	10.000	5.000	ZMRP 4.0000 FT.
						SCALE .0190

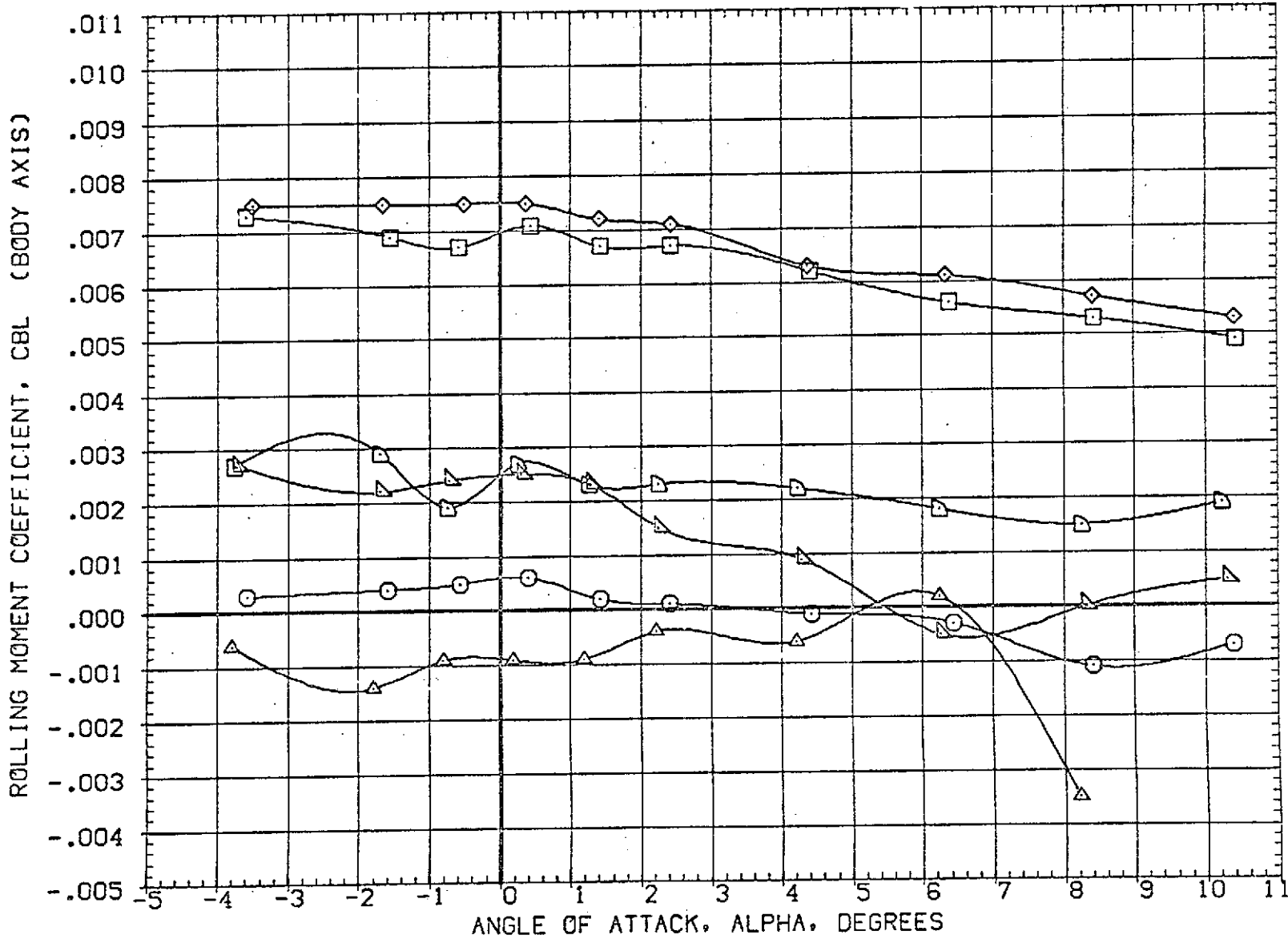

FIG 17 EFFECT OF PLUMES ON ELEVON AND RUDDER POWER, BETA=0.0

(B)MACH = 1.98

DATA SET SYMBOL	CONFIGURATION DESCRIPTION	ELEVON	AILRON	RUDDER	PLUMES	REFERENCE INFORMATION
(RBJ501)	AMES 97-616 IA2 01 TO S1 NO PLUMES	-.000	.000	.000	.000	SREF 3155.0000 SQ.FT.
(RBJ511)	AMES 97-616 IA2 01 TO S1 NO PLUMES	10.000	.000	10.000	.000	LREF 50.8000 FT.
(RBJ521)	DATA NOT AVAILABLE	-10.000	.000	10.000	.000	BREF 73.5000 FT.
(RBJ001)	AMES 97-616 IA2 01 TO S1 PC/PT-NOM.SRM A/A=8	.000	.000	.000	5.000	XMRP 86.4167 FT.
(RBJ011)	AMES 97-616 IA2 01 TO S1 PC/PT-NOM.SRM A/A=8	10.000	.000	10.000	5.000	YMRP .0000 FT.
(RBJ021)	DATA NOT AVAILABLE	-10.000	.000	10.000	5.000	ZMRP 4.0000 FT.
						SCALE .0190

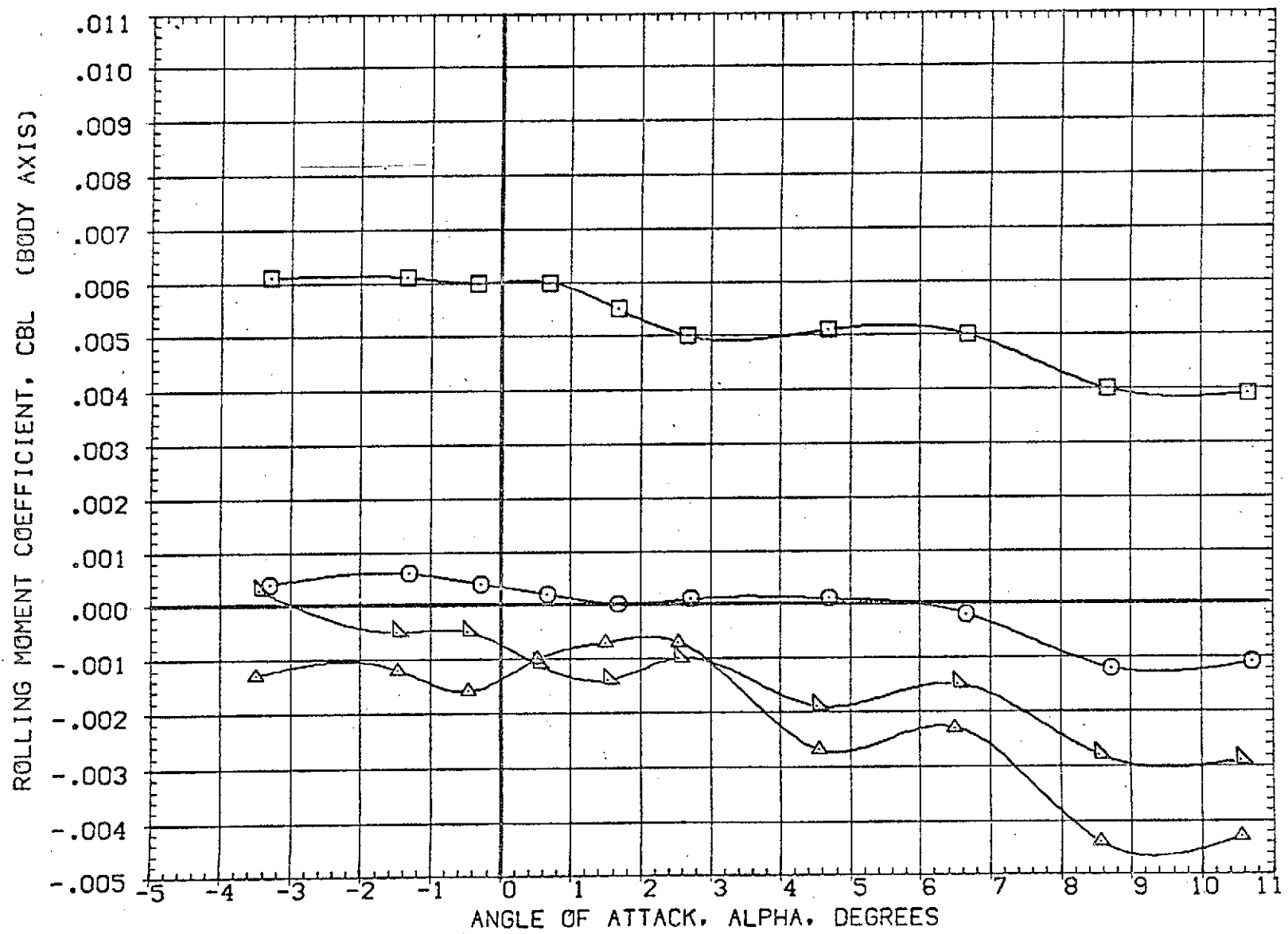

FIG 17 EFFECT OF PLUMES ON ELEVON AND RUDDER POWER, BETA=0.0

(C)MACH = 2.17

DATA SET SYMBOL	CONFIGURATION DESCRIPTION	ELEVON	AILERON	RUDDER	PLUMES	REFERENCE INFORMATION
(BBJ501)	AMES 97-616 1A2 01 TO S1 NO PLUMES	.000	.000	.000	.000	SREF 3155.0000 SO.FT.
(BBJ511)	AMES 97-616 1A2 01 TO S1 NO PLUMES	10.000	.000	10.000	.000	LREF 50.8000 FT.
(BBJ521)	AMES 97-616 1A2 01 TO S1 NO PLUMES	-10.000	.000	10.000	.000	BREF 73.5000 FT.
(BBJ001)	AMES 97-616 1A2 01 TO S1 PC/PT NOM. SRM A/A=8	.000	.000	.000	5.000	XMRP 86.4167 FT.
(BBJ011)	AMES 97-616 1A2 01 TO S1 PC/PT=NOM. SRM A/A=8	10.000	.000	10.000	5.000	YMRP .0000 FT.
(BBJ021)	AMES 97-616 1A2 01 TO S1 PC/PT=NOM. SRM A/A=8	-10.000	.000	10.000	5.000	ZMRP 4.0000 FT.
						SCALE .0190

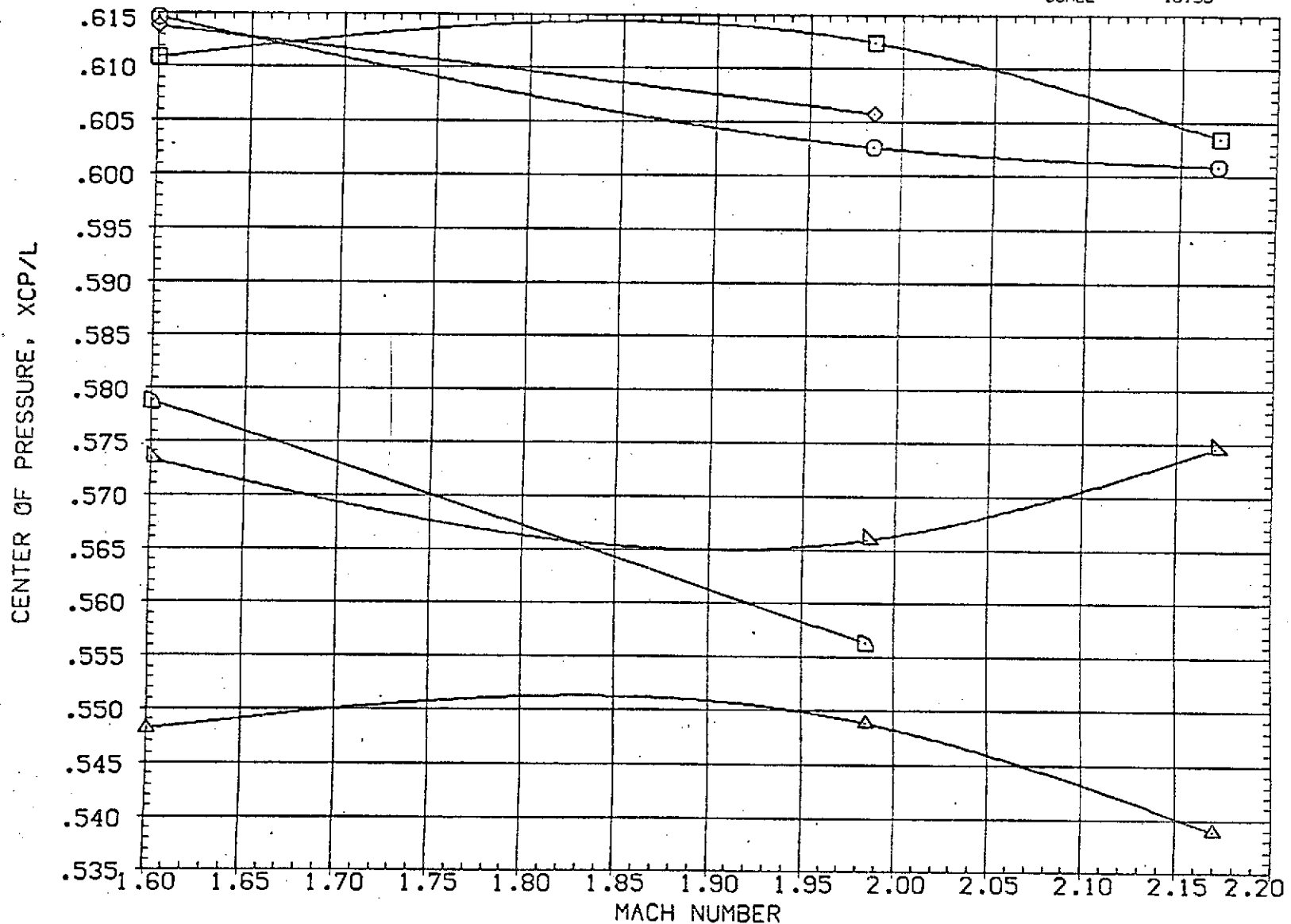

FIG 17 EFFECT OF PLUMES ON ELEVON AND RUDDER POWER, BETA=0.0

DESCRIPTION	ELEVON	AILRON	RUDDER	PLUMES	REFERENCE INFORMATION
(CBJS01) AMES 97-616 IA2 01 TO S1 NO PLUMES	.000	.000	.000	.000	SREF 3155.0000 SQ.FT.
(CBJS11) AMES 97-616 IA2 01 TO S1 NO PLUMES	10.000	.000	10.000	.000	LREF 50.8000 FT.
(CBJS21) AMES 97-616 IA2 01 TO S1 NO PLUMES	-10.000	.000	10.000	.000	BREF 73.5000 FT.
(CBJ001) AMES 97-616 IA2 01 TO S1 PC/PT-NOM.SRM A/A=8	.000	.000	.000	5.000	XMRP 86.4167 FT.
(CBJ011) AMES 97-616 IA2 01 TO S1 PC/PT-NOM.SRM A/A=8	-10.000	.000	10.000	5.000	YMRP .0000 FT.
(CBJ021) AMES 97-616 IA2 01 TO S1 PC/PT-NOM.SRM A/A=8	-10.000	.000	10.000	5.000	ZMRP 4.0000 FT.
					SCALE .0190

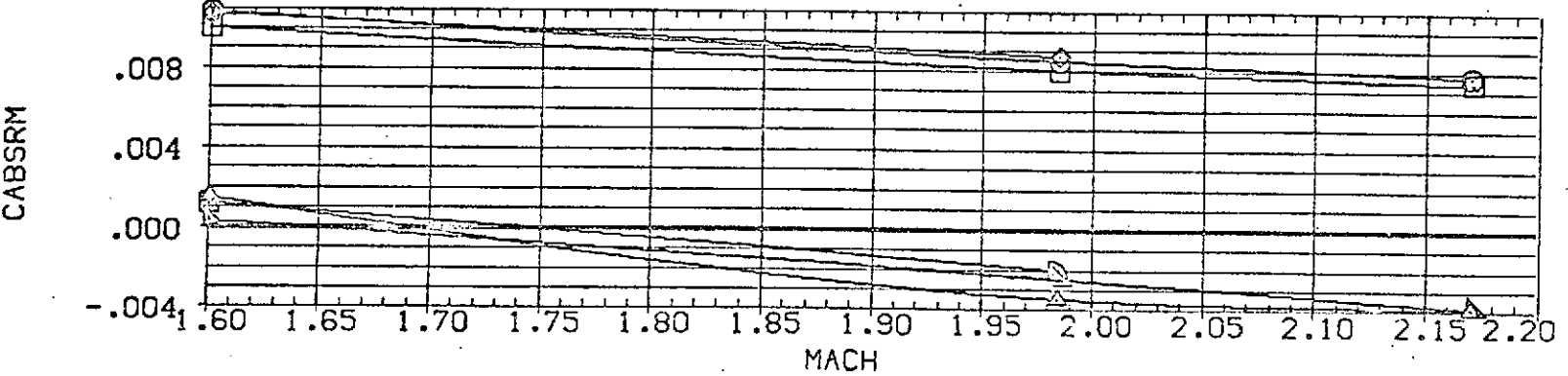
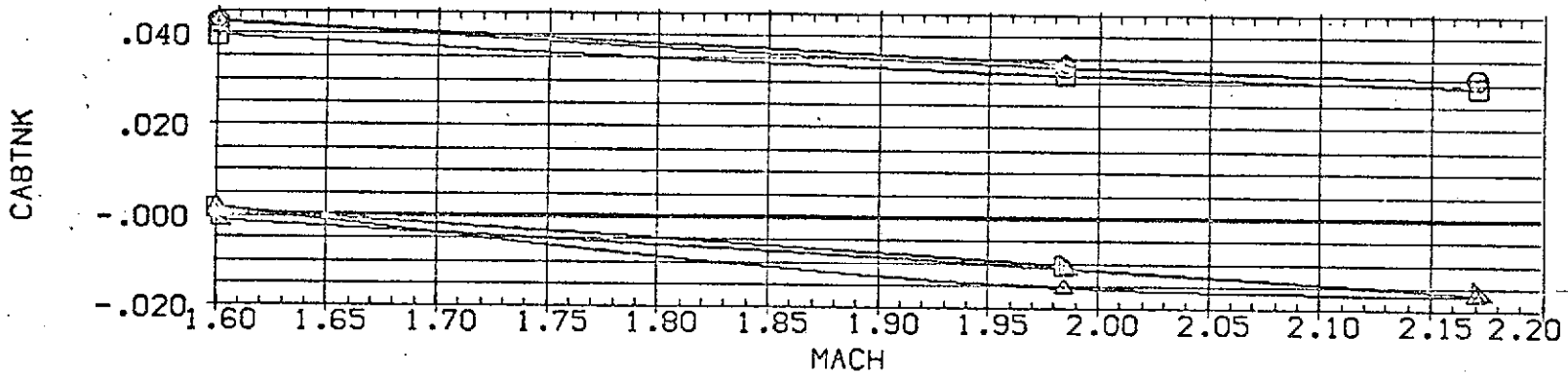
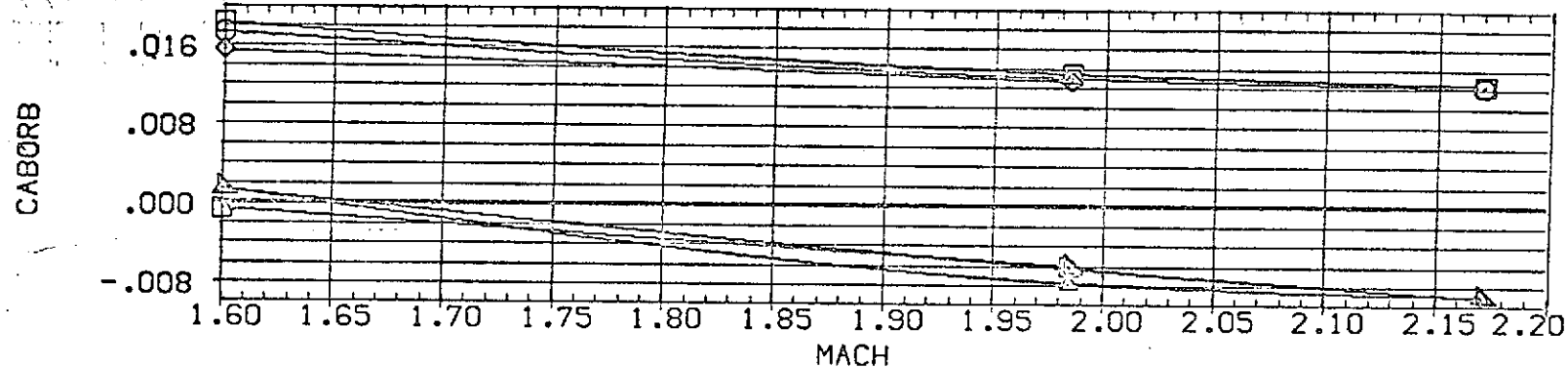

FIG 17 EFFECT OF PLUMES ON ELEVON AND RUDDER POWER, BETA=0.0

DATA SET SYMBOL	CONFIGURATION DESCRIPTION	ELEVON	AILRON	RUDDER	PLUMES	REFERENCE INFORMATION
(RBJ502)	AMES 97-616 IA2 01 TO S1 NO PLUMES	.000	.000	.000	.000	SREF 3155.0000 SQ.FT.
(RBJ512)	AMES 97-616 IA2 01 TO S1 NO PLUMES	10.000	.000	10.000	.000	LREF 50.8000 FT.
(SBJ002)	AMES 97-616 IA2 01 TO S1 PC/PT-NOM.SRM A/A=8	.000	.000	.000	5.000	BREF 73.5000 FT.
(RBJ012)	AMES 97-616 IA2 01 TO S1 PC/PT-NOM.SRM A/A=8	10.000	.000	10.000	5.000	XMRP 86.4167 FT.
						YMRP .0000 FT.
						ZMRP 4.0000 FT.
						SCALE .0190

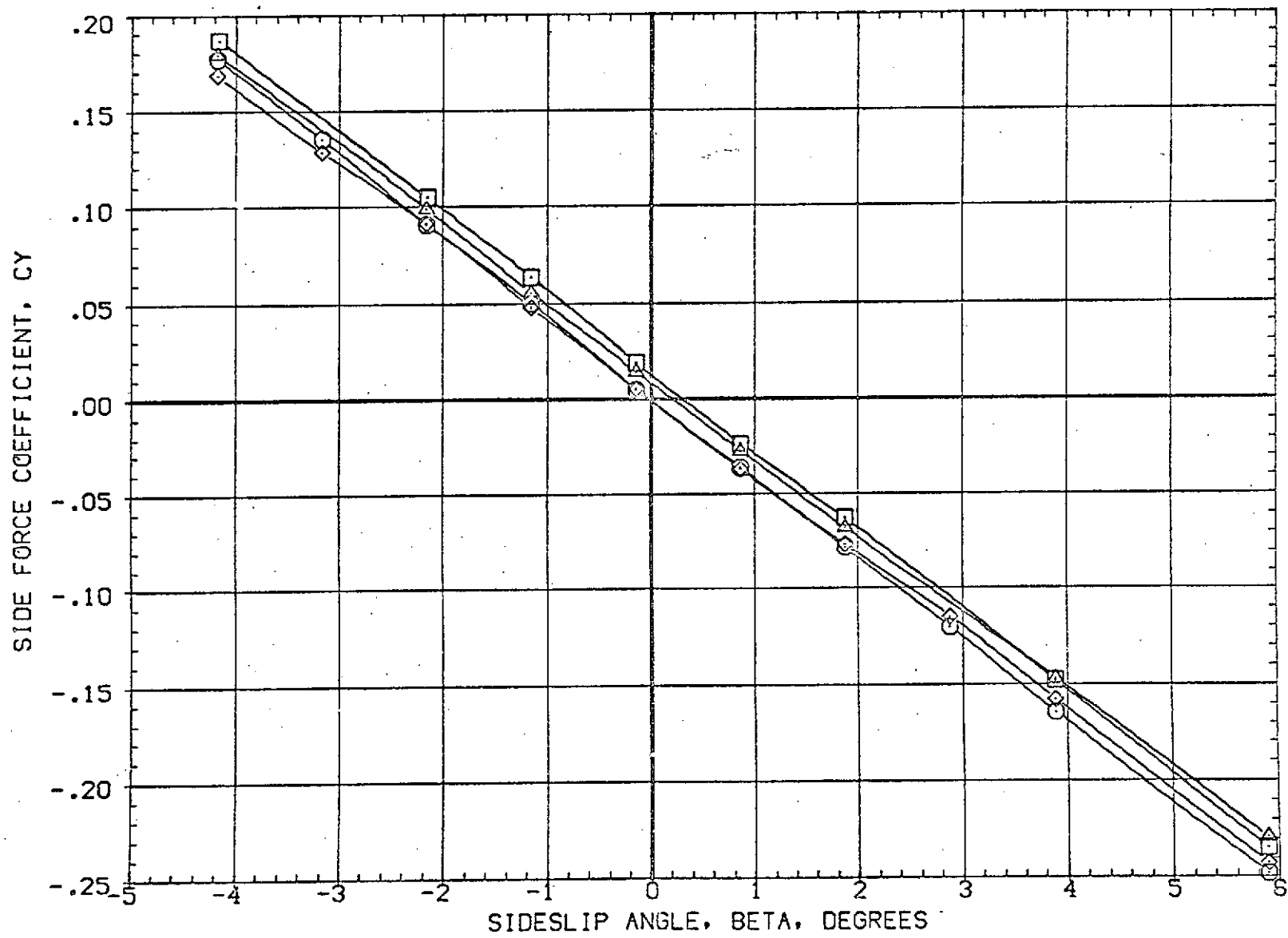

FIG 18 EFFECT OF PLUMES ON ELEVON AND RUDDER POWER, ALPHA=0.0

(A)MACH = 1.60

DATA SET SYMBOL	CONFIGURATION DESCRIPTION	ELEVON	AILERON	RUDDER	PLUMES	REFERENCE INFORMATION	SO. FT.
(RB)502)	AMES 97-616 1A2 01 TO S1 NO PLUMES	.000	.000	.000	.000	SREF	3155.0000
(RB)512)	AMES 97-616 1A2 01 TO S1 NO PLUMES	10.000	.000	10.000	.000	LREF	50.8000
(SB)002)	AMES 97-616 1A2 01 TO S1 PC/PT NOM. SRM A/A=8	.000	.000	.000	5.000	BREF	73.5000
(RB)012)	AMES 97-616 1A2 01 TO S1 PC/PT-NOM. SRM A/A=8	10.000	.000	10.000	5.000	XMRP	86.4167
						YMRP	.0000
						ZMRP	4.0000
						SCALE	.0190

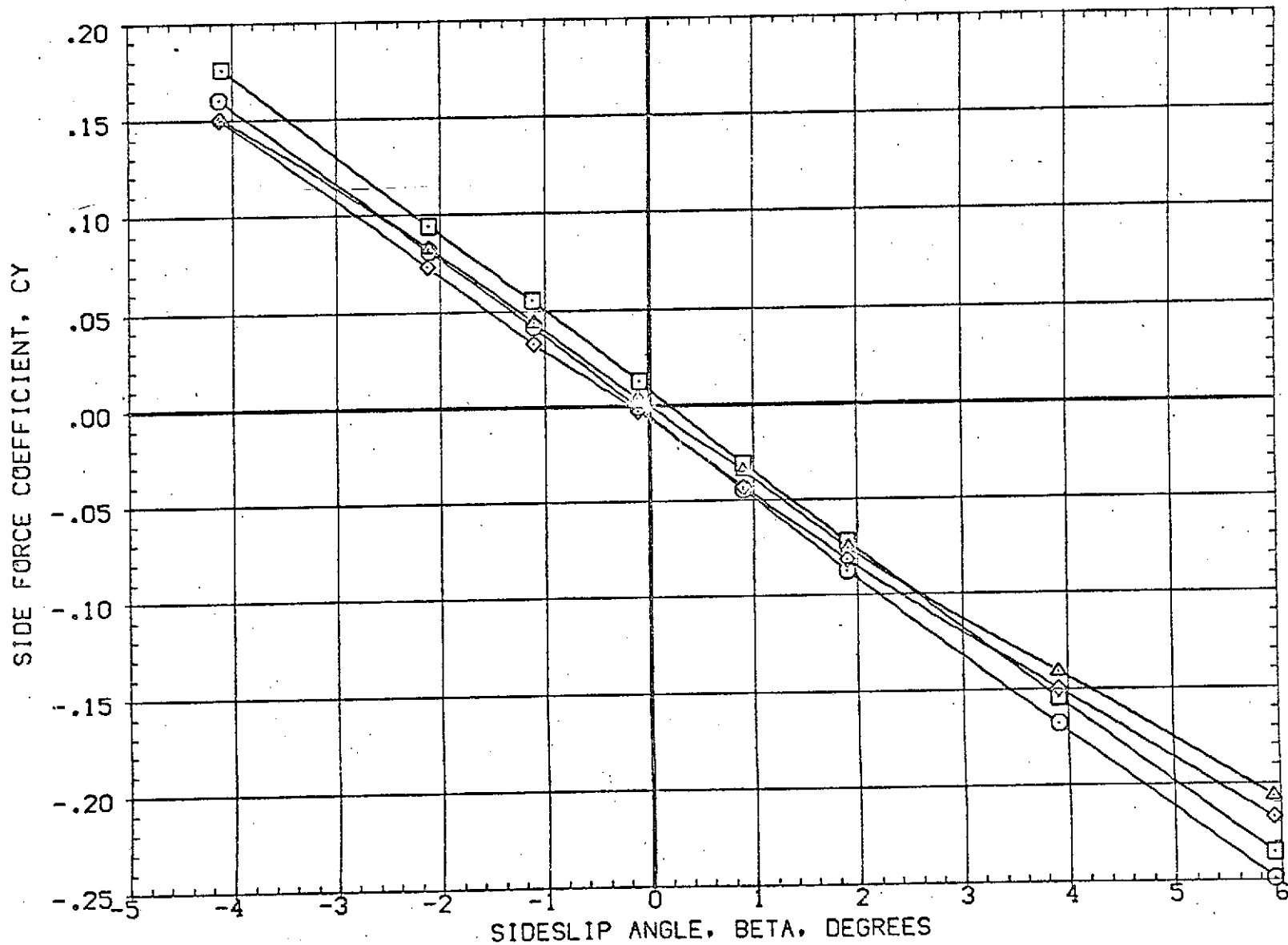

FIG 18 EFFECT OF PLUMES ON ELEVON AND RUDDER POWER, ALPHA=0.0

(B)MACH = 1.98

DATA SET SYMBOL	CONFIGURATION DESCRIPTION	ELEVON	AILERON	RUDDER	PLUMES	REFERENCE INFORMATION
(RBJ502)	AMES 97-616 1A2 01 TO S1 NO PLUMES	.000	.000	.000	.000	SREF 3155.0000 SQ.FT.
(RBJ512)	AMES 97-616 1A2 01 TO S1 NO PLUMES	10.000	.000	10.000	.000	LREF 50.8000 FT.
(RBJ002)	AMES 97-616 1A2 01 TO S1 PC/PT-NOM.SRM A/A=8	.000	.000	.000	5.000	BREF 73.5000 FT.
(RBJ012)	AMES 97-616 1A2 01 TO S1 PC/PT-NOM.SRM A/A=8	10.000	.000	10.000	5.000	XMRP 86.4167 FT. YMRP .0000 FT. ZMRP 4.0000 FT. SCALE .0190

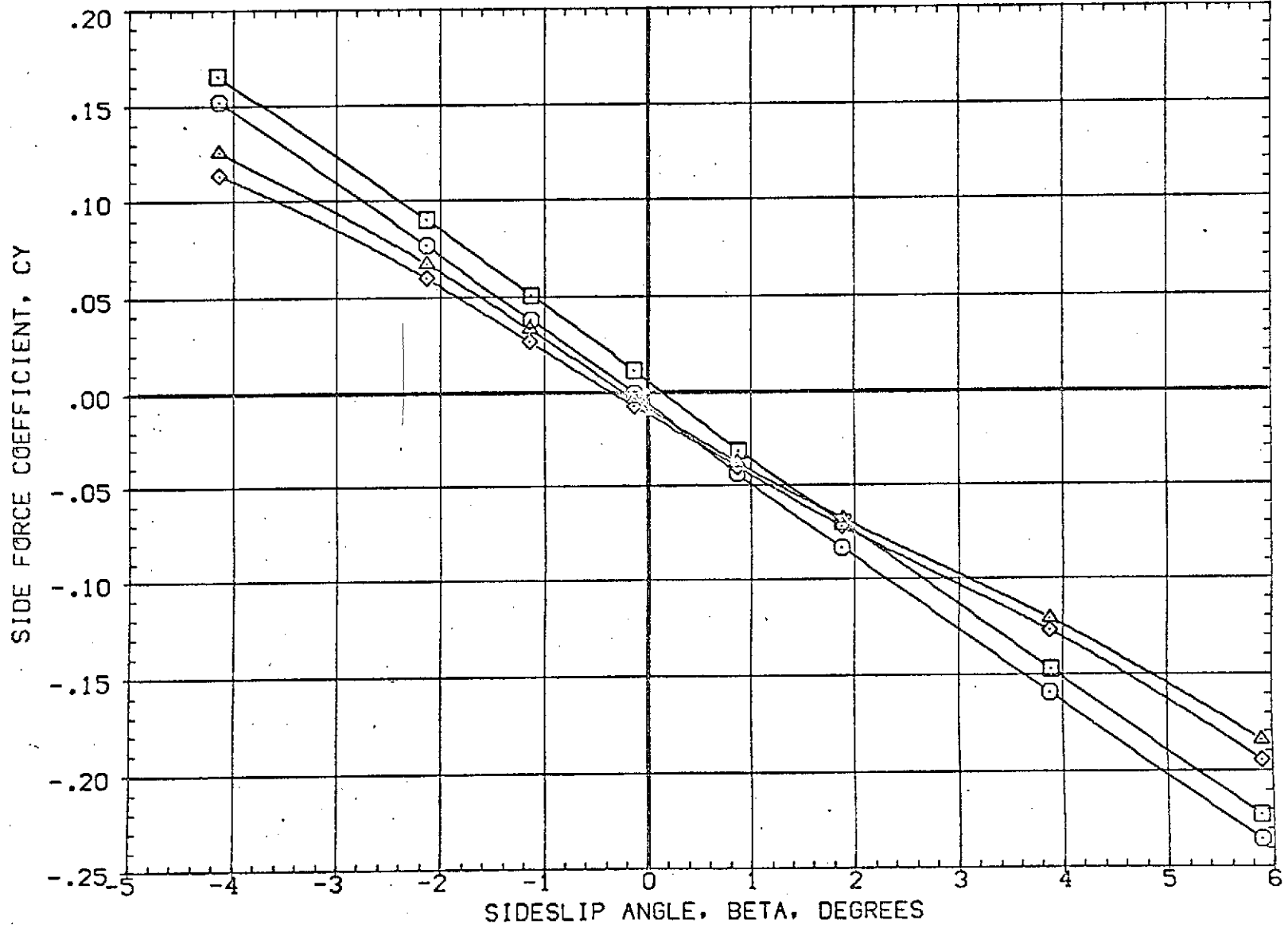

FIG 18 EFFECT OF PLUMES ON ELEVON AND RUDDER POWER, ALPHA=0.0

DATA SET SYMBOL	CONFIGURATION DESCRIPTION	ELEVON	AILERON	RUDDER	PLUMES	REFERENCE INFORMATION		
{RBJS02}	AMES 97-616 1A2 01 TO S1 NO PLUMES	.000	.000	.000	.000	SREF	3155.0000	SQ.FT.
{RBJS12}	AMES 97-616 1A2 01 TO S1 NO PLUMES	10.000	.000	10.000	.000	LREF	50.8000	FT.
{SBJS02}	AMES 97-616 1A2 01 TO S1 PC/PT-NOM,SRM A/A=8	.000	.000	.000	5.000	BREF	73.5000	FT.
{RBJS12}	AMES 97-616 1A2 01 TO S1 PC/PT-NOM,SRM A/A=8	10.000	.000	10.000	5.000	XMRP	86.4167	FT.
						YMRP	.0000	FT.
						ZMRP	4.0000	FT.
						SCALE	.0190	

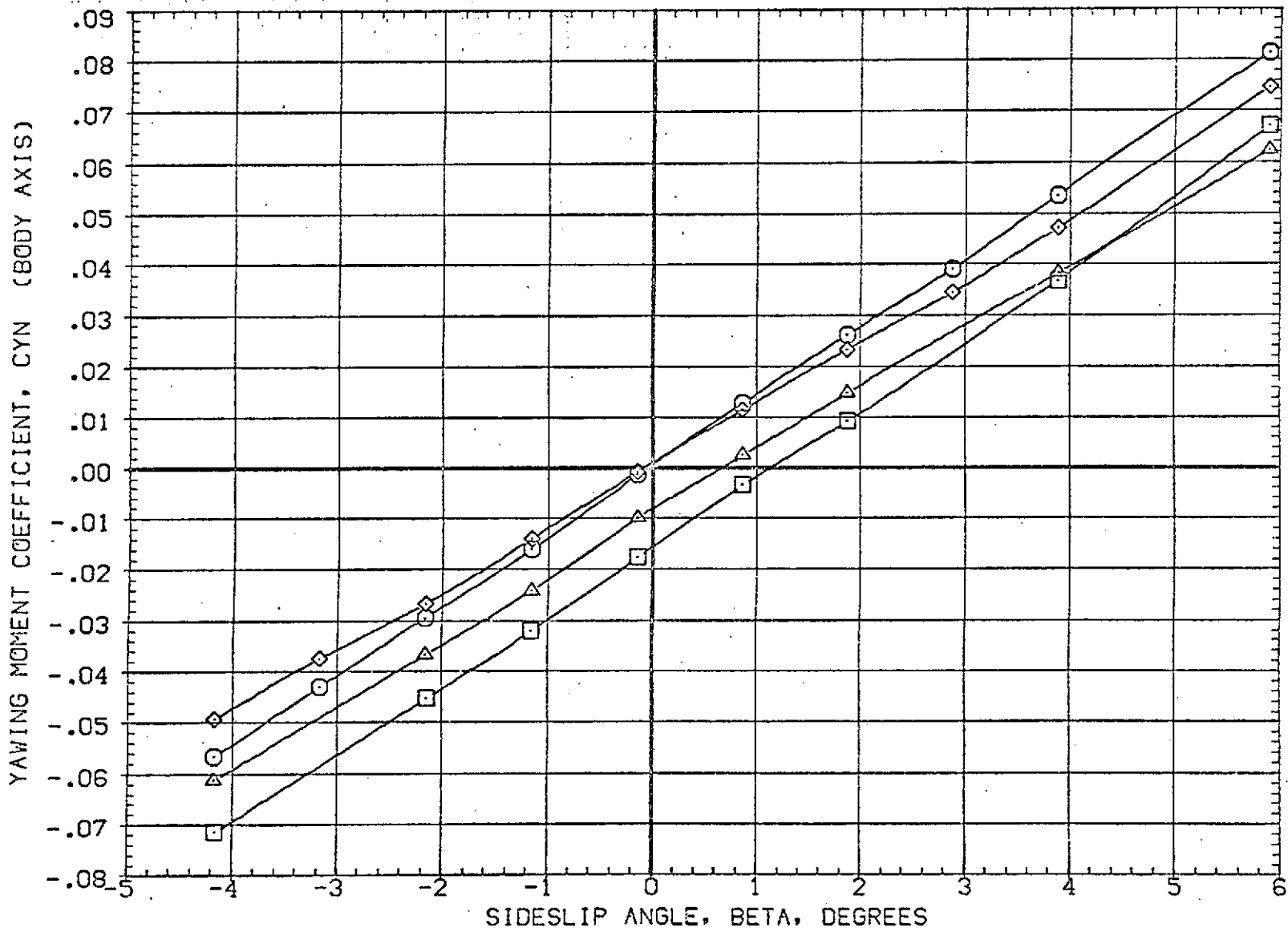

FIG 18 EFFECT OF PLUMES ON ELEVON AND RUDDER POWER, ALPHA=0.0

(A)MACH = 1.60

DATA SET SYMBOL	CONFIGURATION DESCRIPTION	ELEVON	AILRON	RUDDER	PLUMES	REFERENCE INFORMATION
(RBJ502)	AMES 97-616 1A2 01 TO S1 NO PLUMES	.000	.000	.000	.000	SREF 3155.0000 SQ.FT.
(RBJ512)	AMES 97-616 1A2 01 TO S1 NO PLUMES	10.000	.000	10.000	.000	LREF 50.8000 FT.
(SBJ002)	AMES 97-616 1A2 01 TO S1 PC/PT NCM.SRM A/A=8	.000	.000	.000	5.000	BREF 73.5000 FT.
(RBJ012)	AMES 97-616 1A2 01 TO S1 PC/PT=NCM.SRM A/A=8	10.000	.000	10.000	5.000	XMRP 86.4167 FT.
						YMRP .0000 FT.
						ZMRP 4.0000 FT.
						SCALE .0190

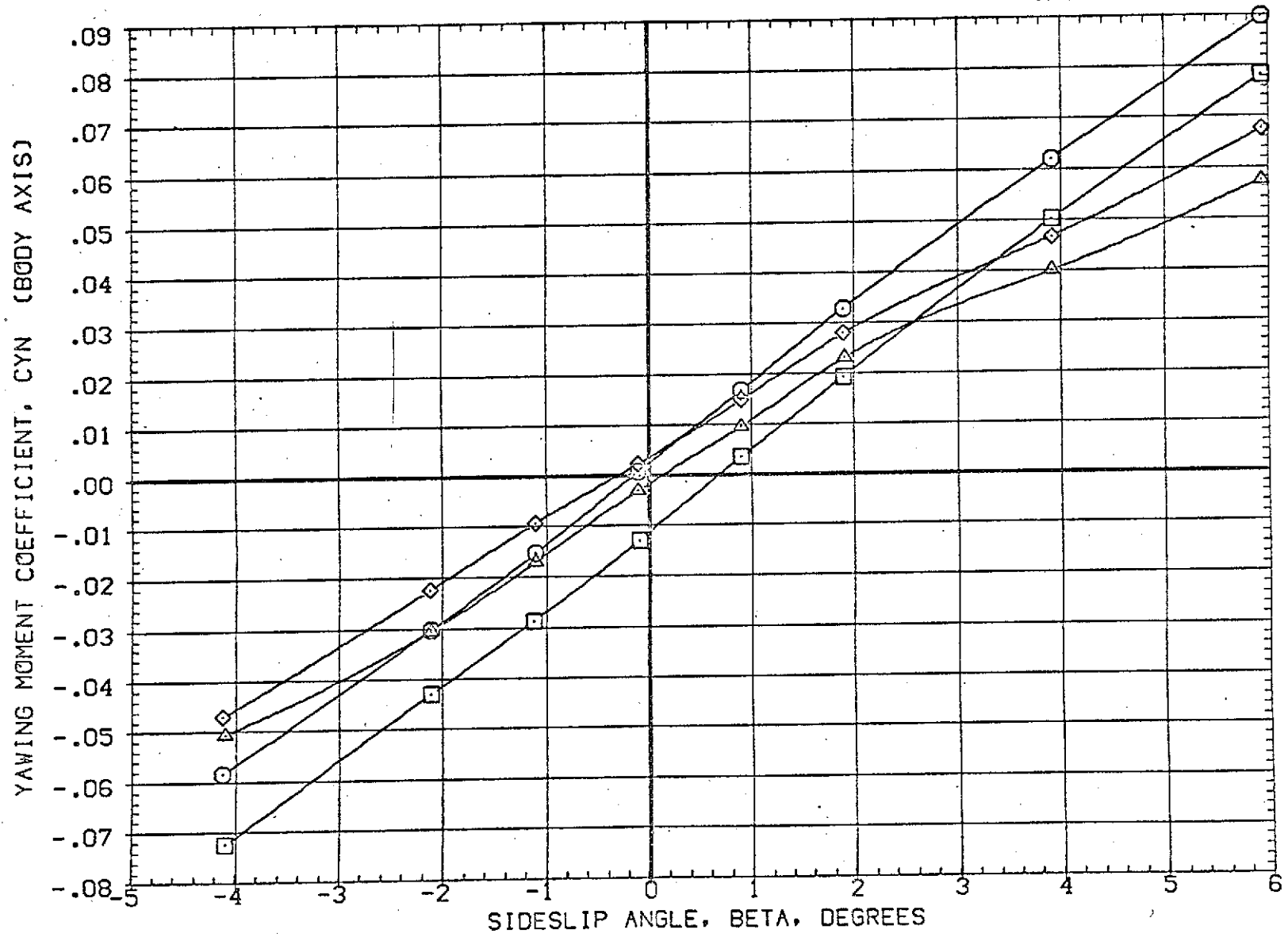

FIG 18 EFFECT OF PLUMES ON ELEVON AND RUDDER POWER, ALPHA=0.0

DATA SET SYMBOL	CONFIGURATION DESCRIPTION	ELEVON	AILERON	RUDDER	PLUMES	REFERENCE INFORMATION
(RBJS02)	AMES 97-616 1A2 01 T3 S1 NO PLUMES	.000	.000	.000	.000	SREF 3155.0000 SQ.FT.
(RBJS12)	AMES 97-616 1A2 01 T0 S1 NO PLUMES	10.000	.000	10.000	.000	LREF 50.8000 FT.
(S9J002)	AMES 97-616 1A2 01 T0 S1 PC/PT NCM, SRM A/A=8	.000	.000	.000	5.000	BREF 73.5000 FT.
(RBJO12)	AMES 97-616 1A2 01 T0 S1 PC/PT=NCM, SRM A/A=8	10.000	.000	10.000	5.000	XMRP 86.4167 FT.
						YMRP .0000 FT.
						ZMRP 4.0000 FT.
						SCALE .0190

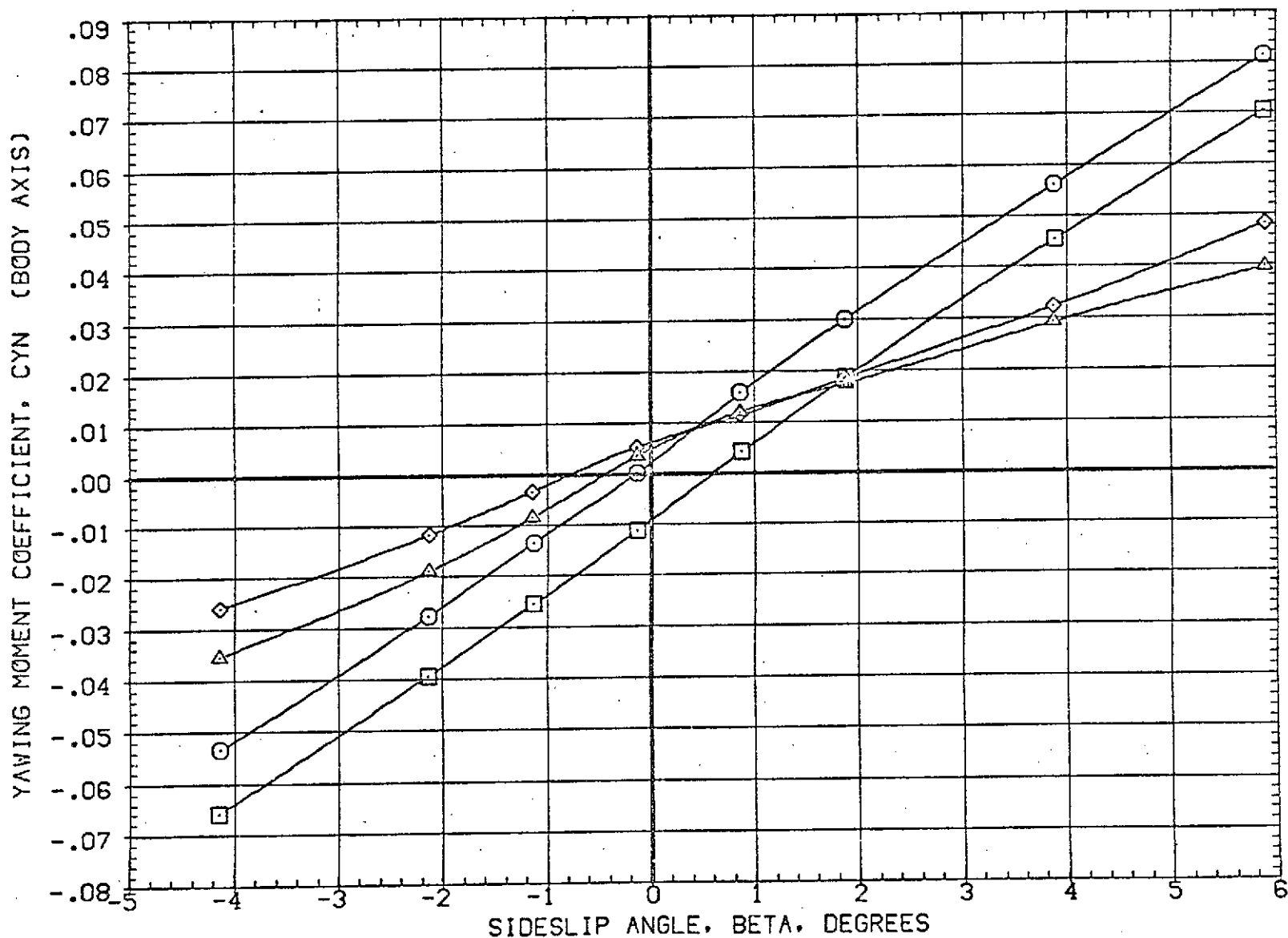

FIG 18 EFFECT OF PLUMES ON ELEVON AND RUDDER POWER, ALPHA=0.0

(C)MACH = 2.17

DATA SET SYMBOL	CONFIGURATION DESCRIPTION	ELEVON	AILRON	RUDDER	PLUMES	REFERENCE INFORMATION
(RBJ502)	AMES 97-616 IA2 01 TO S1 NO PLUMES	.000	.000	.000	.000	SREF 3155.0000 SQ.FT.
(RBJ512)	AMES 97-616 IA2 01 TO S1 NO PLUMES	10.000	.000	10.000	.000	LREF 50.8000 FT.
(SBJ002)	AMES 97-616 IA2 01 TO S1 PC/PT NOM. SRM A/A=8	.000	.000	.000	5.000	BREF 73.5000 FT.
(RBJ012)	AMES 97-616 IA2 01 TO S1 PC/PT=NOM. SRM A/A=8	10.000	.000	10.000	5.000	XMRP 66.4167 FT. YMRP .0000 FT. ZMRP 4.0000 FT. SCALE .0190

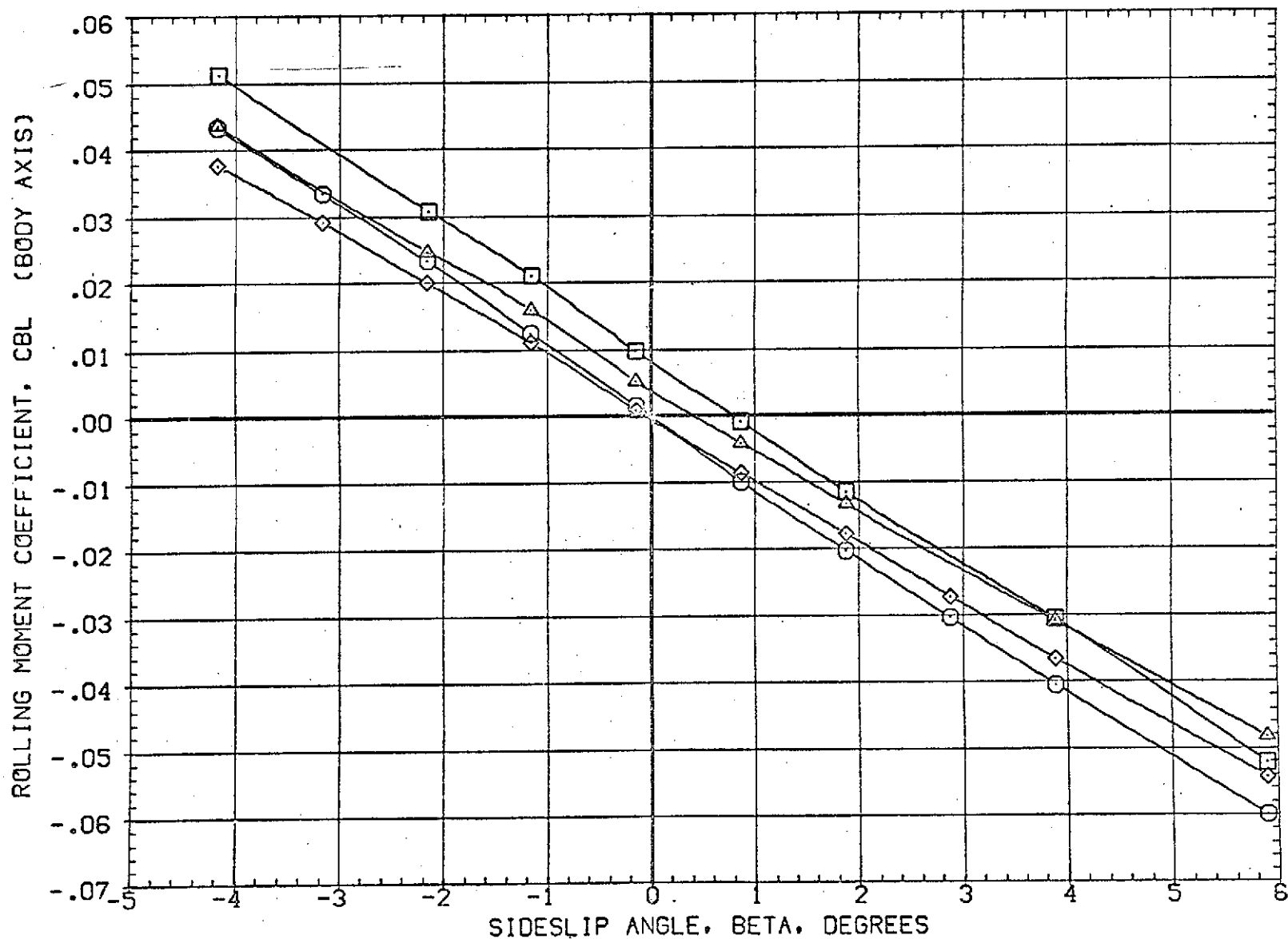

FIG 18 EFFECT OF PLUMES ON ELEVON AND RUDDER POWER, ALPHA=0.0

(A)MACH = 1.60

DATA SET SYMBOL	CONFIGURATION DESCRIPTION	ELEVON	AILRON	RUDDER	PLUMES	REFERENCE INFORMATION	
(RBJ502)	AMES 97-616 1A2 01 TO S1 NO PLUMES	.000	.000	.000	.000	SREF	3155.0000 SQ.FT.
(RBJ512)	AMES 97-616 1A2 01 TO S1 NO PLUMES	10.000	.000	10.000	.000	LREF	50.8000 FT.
(SBJ002)	AMES 97-616 1A2 01 TO S1 PC/PT-NOM,SRM A/A=8	.000	.000	.000	5.000	BREF	73.5000 FT.
(RBJ012)	AMES 97-616 1A2 01 TO S1 PC/PT-NOM,SRM A/A=8	10.000	.000	10.000	5.000	XM RP	86.4167 FT.
						YM RP	.0000 FT.
						ZM RP	4.0000 FT.
						SCALE	.0190

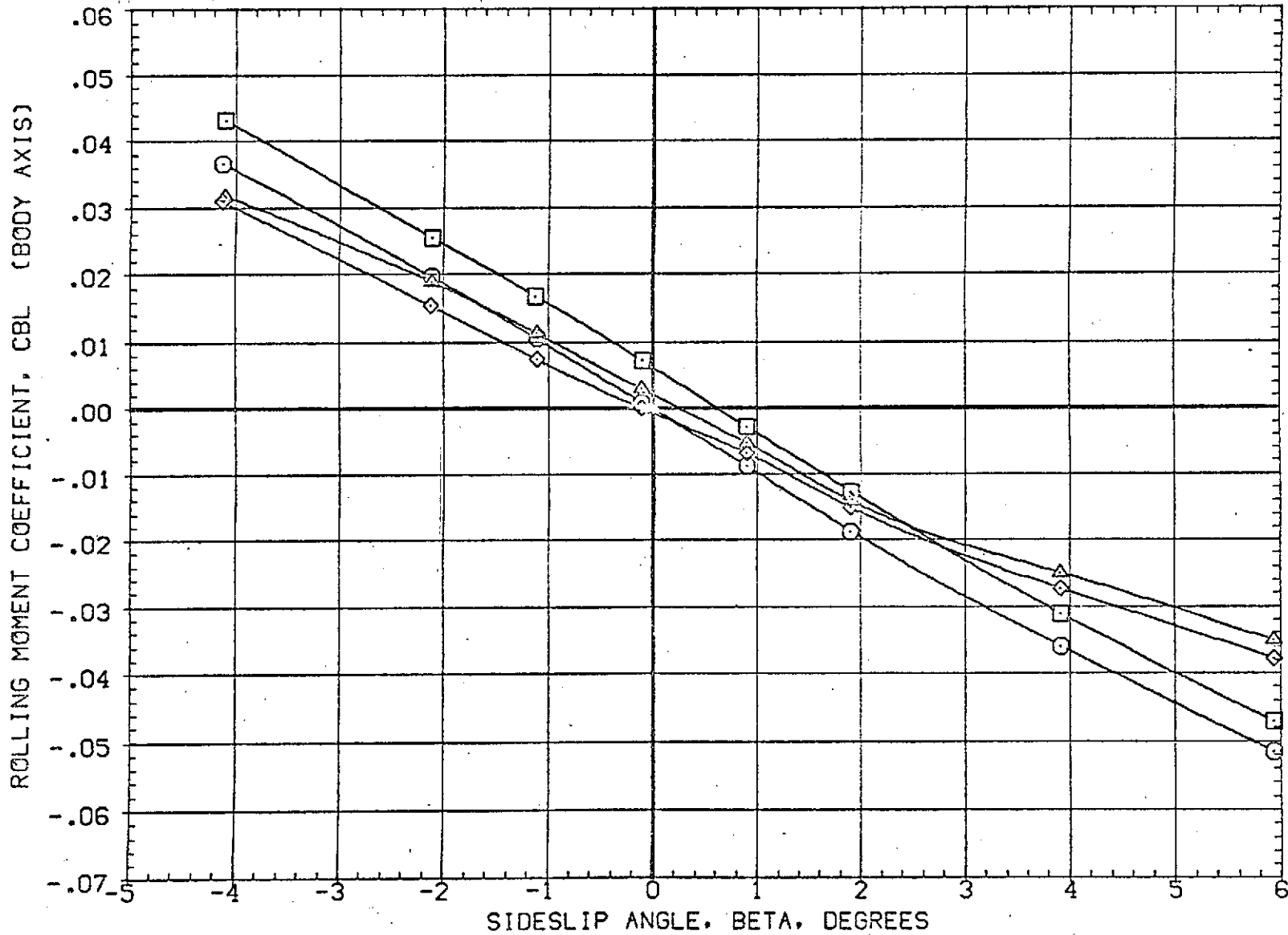

FIG 18 EFFECT OF PLUMES ON ELEVON AND RUDDER POWER, ALPHA=0.0

(B)MACH = 1.98

DATA SET SYMBOL	CONFIGURATION DESCRIPTION	ELEVON	AILRON	RUDDER	PLUMES	REFERENCE INFORMATION	
(RBJ502)	AMES 97-616 1A2 01 TO S1 NO PLUMES	.000	.000	.000	.000	SREF	3155.0000 SO.FT.
(RBJ512)	AMES 97-616 1A2 01 TO S1 NO PLUMES	10.000	.000	10.000	.000	LREF	50.8000 FT.
(RBJ002)	AMES 97-616 1A2 01 TO S1 PC/PT-NOM,SRM A/A=8	.000	.000	.000	5.000	BREF	73.5000 FT.
(RBJ012)	AMES 97-616 1A2 01 TO S1 PC/PT-NOM,SRM A/A=8	10.000	.000	10.000	5.000	XMRP	86.4167 FT.
						YMRP	.0000 FT.
						ZMRP	4.0000 FT.
						SCALE	.0190

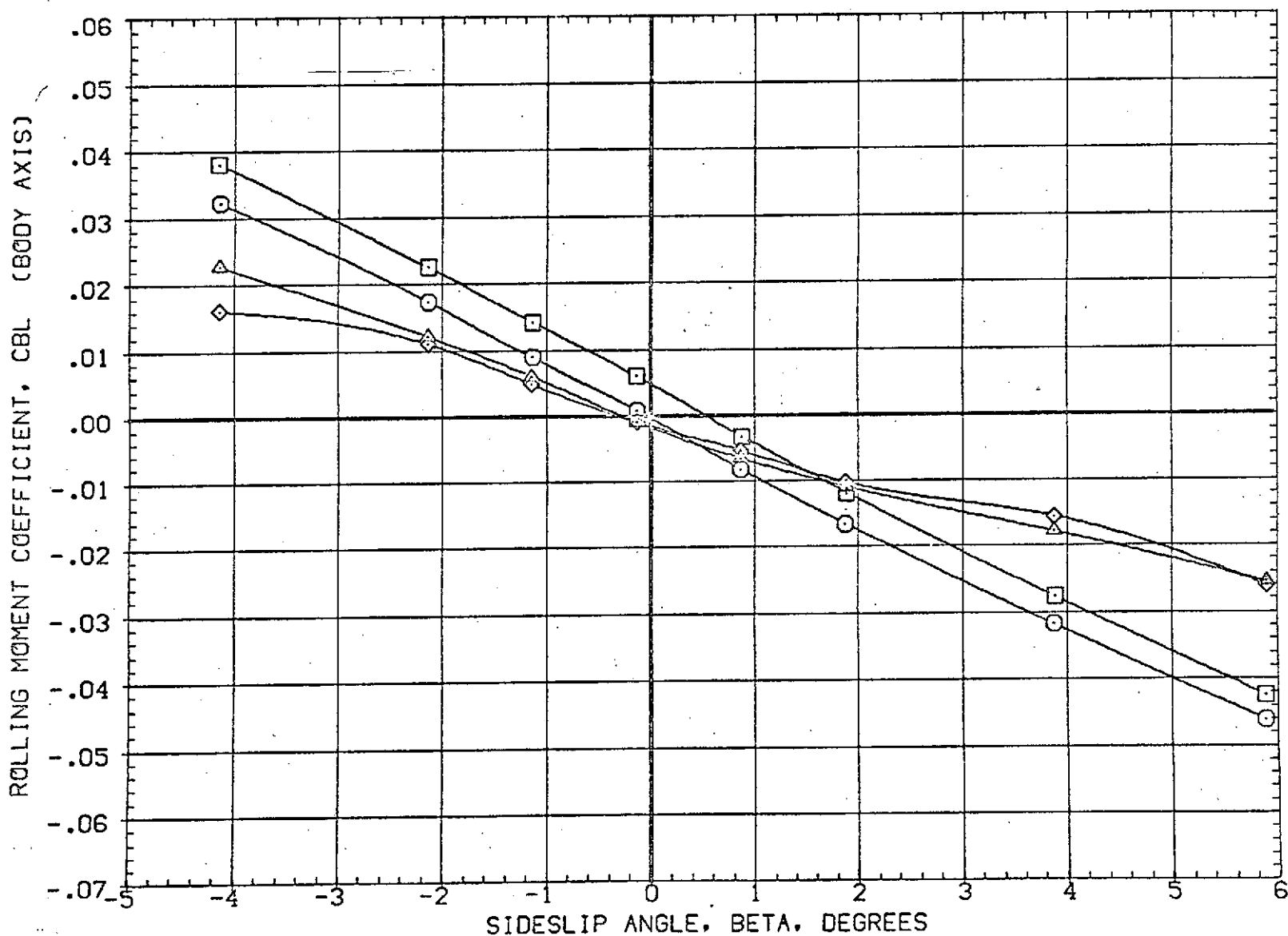

FIG 18 EFFECT OF PLUMES ON ELEVON AND RUDDER POWER, ALPHA=0.0

(C)MACH = 2.17

DATA SET SYMBOL	CONFIGURATION DESCRIPTION	ELEVON	AILERON	RUDDER	PLUMES	REFERENCE INFORMATION	
(RBJS02)	AMES 97-616 1A2 01 TO S1 NO PLUMES	.000	.000	.000	.000	SREF	3155.0000 SQ.FT.
(RBJS12)	AMES 97-616 1A2 01 TO S1 NO PLUMES	10.000	.000	10.000	.000	LREF	50.8000 FT.
(SBJS02)	AMES 97-616 1A2 01 TO S1 PC/PT-NOM.SRM A/A-8	.000	.000	.000	5.000	BREF	73.5000 FT.
(SBJS12)	AMES 97-616 1A2 01 TO S1 PC/PT-NOM.SRM A/A-8	10.000	.000	10.000	5.000	XMRP	86.4167 FT.
						YMRP	.0000 FT.
						ZMRP	4.0000 FT.
						SCALE	.0190

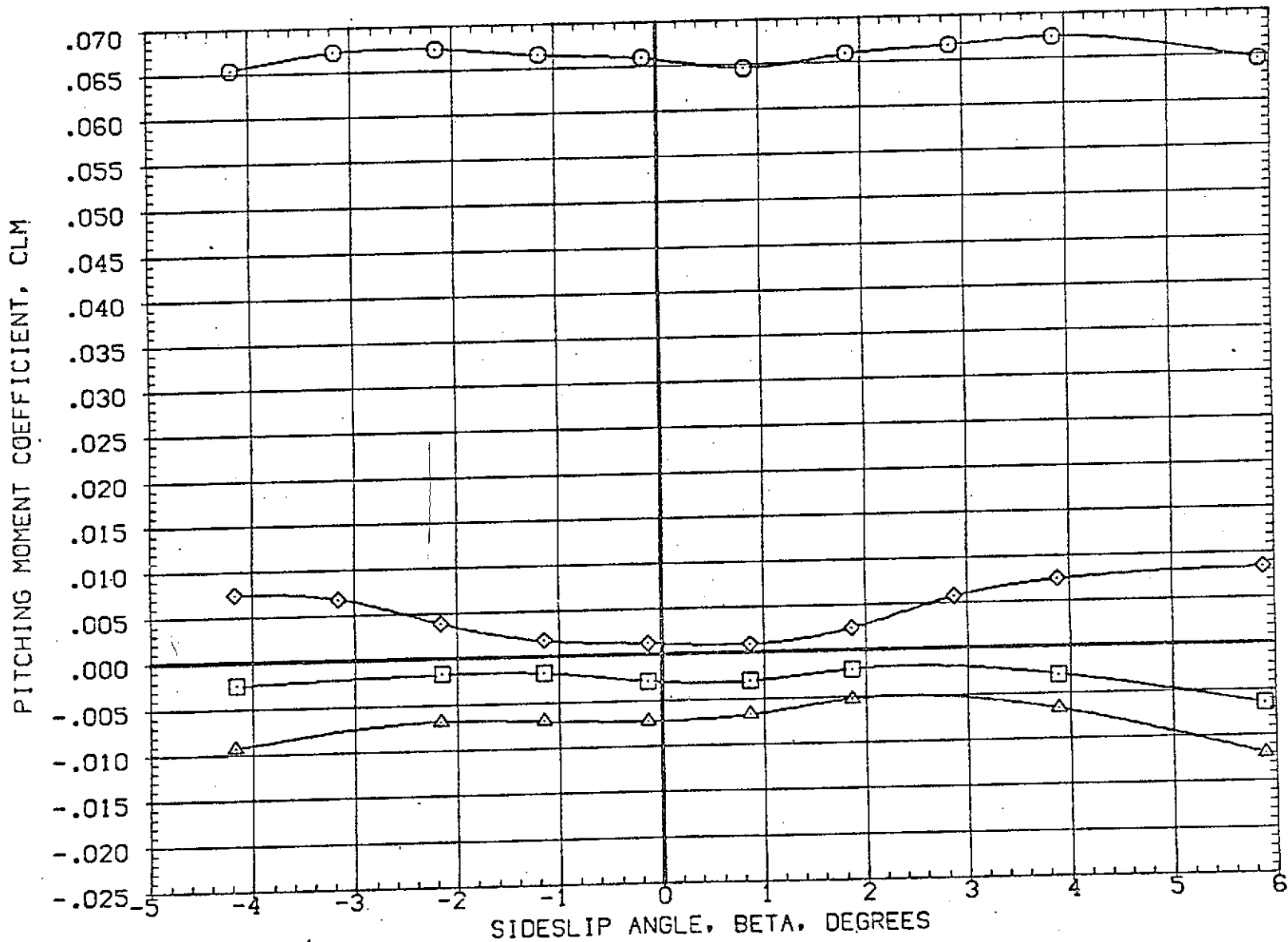

FIG 18 EFFECT OF PLUMES ON ELEVON AND RUDDER POWER, ALPHA=0.0

(A)MACH = 1.60

DATA SET SYMBOL	CONFIGURATION DESCRIPTION	ELEVON	AILRON	RUDDER	PLUMES	REFERENCE INFORMATION	
(RBJS02)	AMES 97-616 1A2 01 TO S1 NO PLUMES	.000	.000	.000	.000	SREF	3155.0000 SQ.FT.
(RBJS12)	AMES 97-616 1A2 01 TO S1 NO PLUMES	10.000	.000	10.000	.000	LREF	50.8000 FT.
(SBJ002)	AMES 97-616 1A2 01 TO S1 PC/PT-NOM.SRM A/A=8	.000	.000	.000	5.000	BREF	73.5000 FT.
(RBJS12)	AMES 97-616 1A2 01 TO S1 PC/PT-NOM.SRM A/A=8	10.000	.000	10.000	5.000	XMRP	86.4167 FT.
						YMRP	.0000 FT.
						ZMRP	4.0000 FT.
						SCALE	.0190

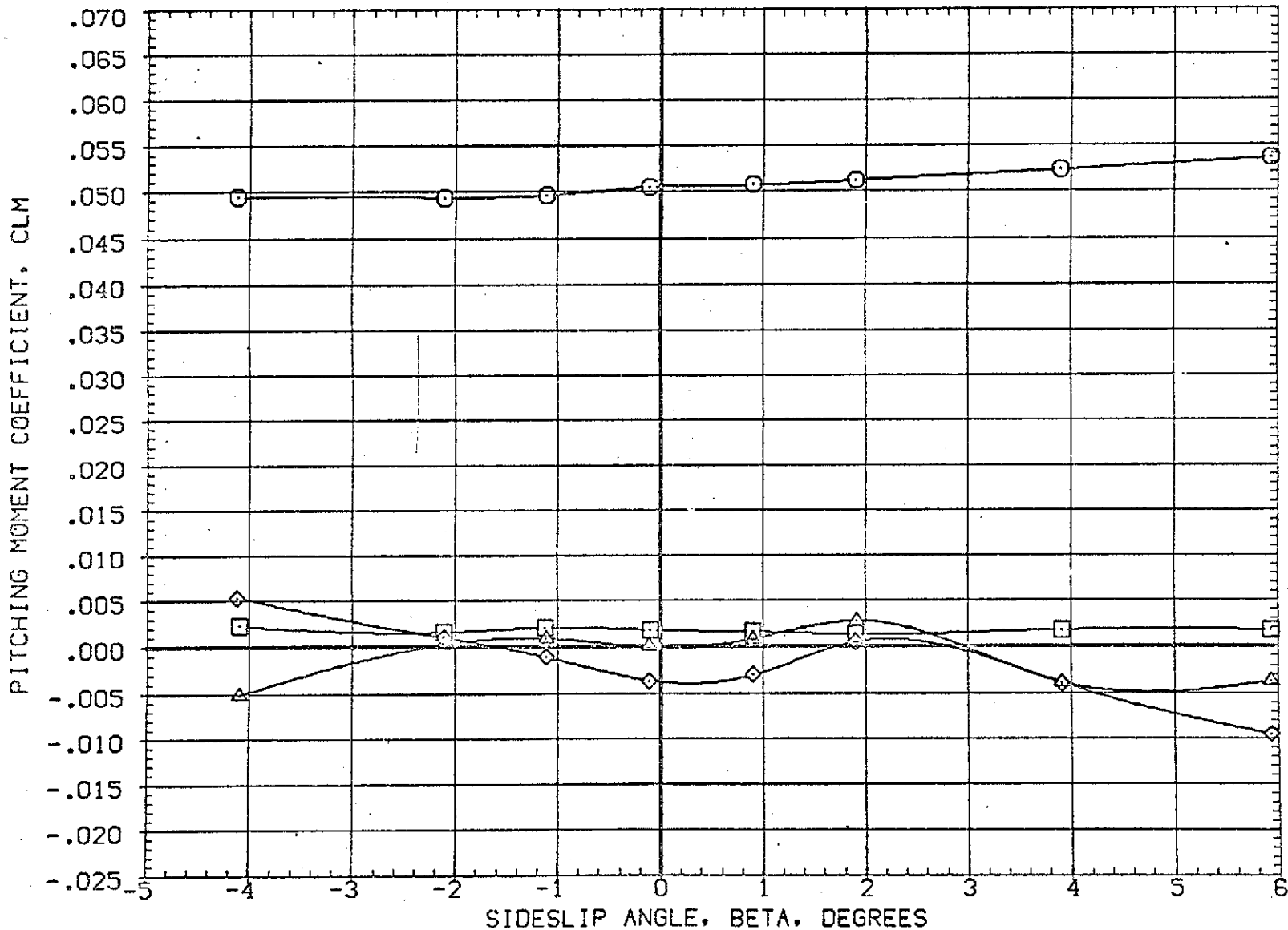

FIG 18 EFFECT OF PLUMES ON ELEVON AND RUDDER POWER, ALPHA=0.0

(B)MACH = 1.98

DATA SET SYMBOL	CONFIGURATION DESCRIPTION	ELEVON	AILRON	RUDDER	PLUMES	REFERENCE INFORMATION		
(RBJ502)	AMES 97-616 1A2 01 TO S1 NO PLUMES	.000	.000	.000	.000	SREF	3155.0000	50.000 FT.
(RBJ512)	AMES 97-616 1A2 01 TO S1 NO PLUMES	10.000	.000	10.000	.000	LREF	50.8000	50.8000 FT.
(SBJ002)	AMES 97-616 1A2 01 TO S1 PC/PT NOM, SRM A/A=8	.000	.000	.000	5.000	BREF	73.5000	73.5000 FT.
(RBJ012)	AMES 97-616 1A2 01 TO S1 PC/PT=NOM, SRM A/A=8	10.000	.000	10.000	5.000	XMRF	86.4167	86.4167 FT.
						YMRF	.0000	.0000 FT.
						ZMRF	4.0000	4.0000 FT.
						SCALE	.0190	

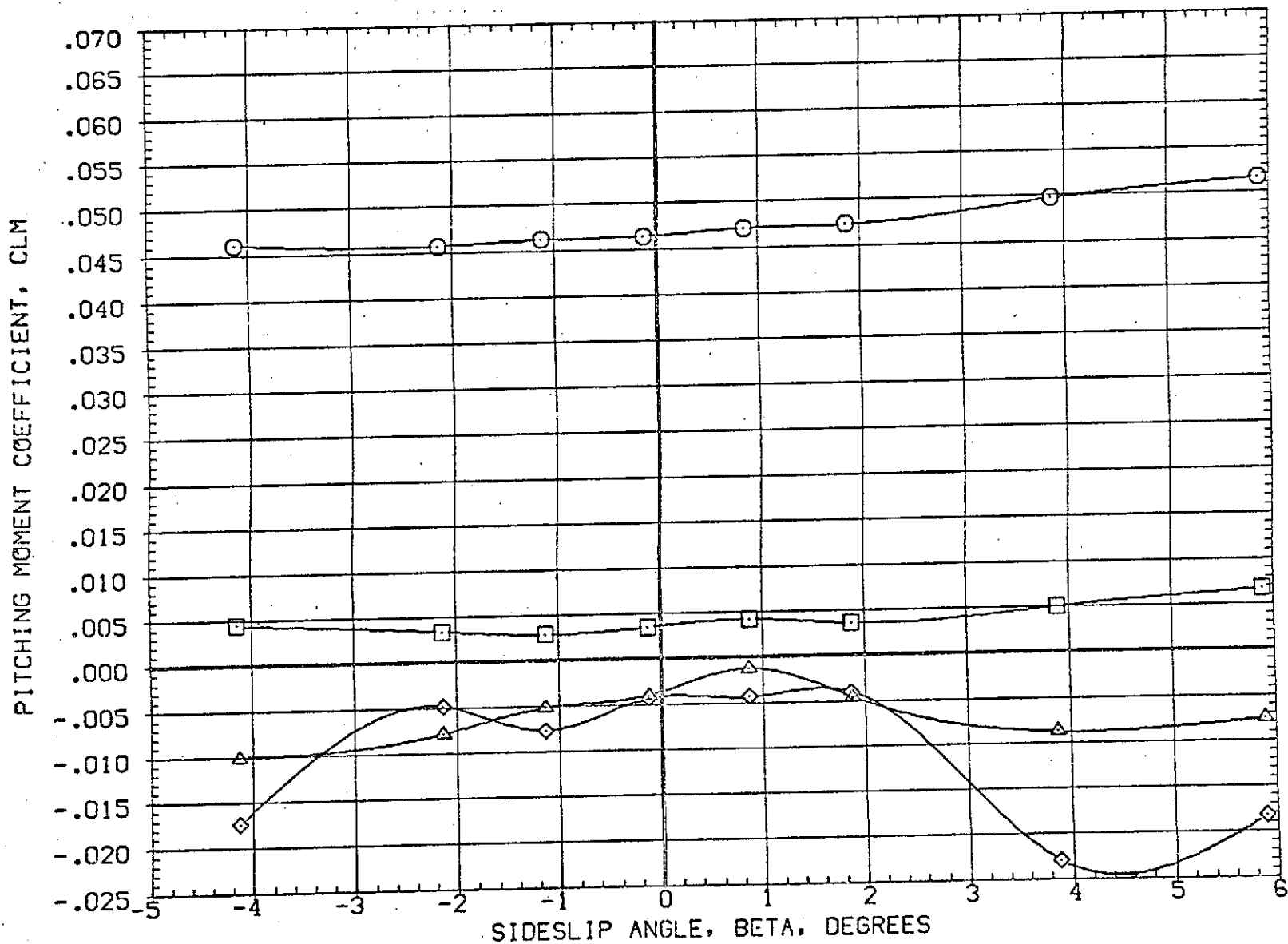

FIG 18 EFFECT OF PLUMES ON ELEVON AND RUDDER POWER, ALPHA=0.0

(C)MACH = 2.17

DATA SET SYMBOL	CONFIGURATION DESCRIPTION	ELEVON	AILRON	RUDDER	PLUMES	REFERENCE INFORMATION	
(RBJ502)	AMES 97-616 1A2 01 TO S1 NO PLUMES	.000	.000	.000	.000	SREF	3155.0000 SQ.FT.
(RBJ512)	AMES 97-616 1A2 01 TO S1 NO PLUMES	10.000	.000	10.000	.000	LREF	50.8000 FT.
(SBJ002)	AMES 97-616 1A2 01 TO S1 PC/PT-NOM.SRM A/A=8	.000	.000	.000	5.000	BREF	73.5000 FT.
(RBJ012)	AMES 97-616 1A2 01 TO S1 PC/PT-NOM.SRM A/A=8	10.000	.000	10.000	5.000	XMRP	86.4167 FT.
						YMRP	.0000 FT.
						ZMRP	4.0000 FT.
						SCALE	.0190

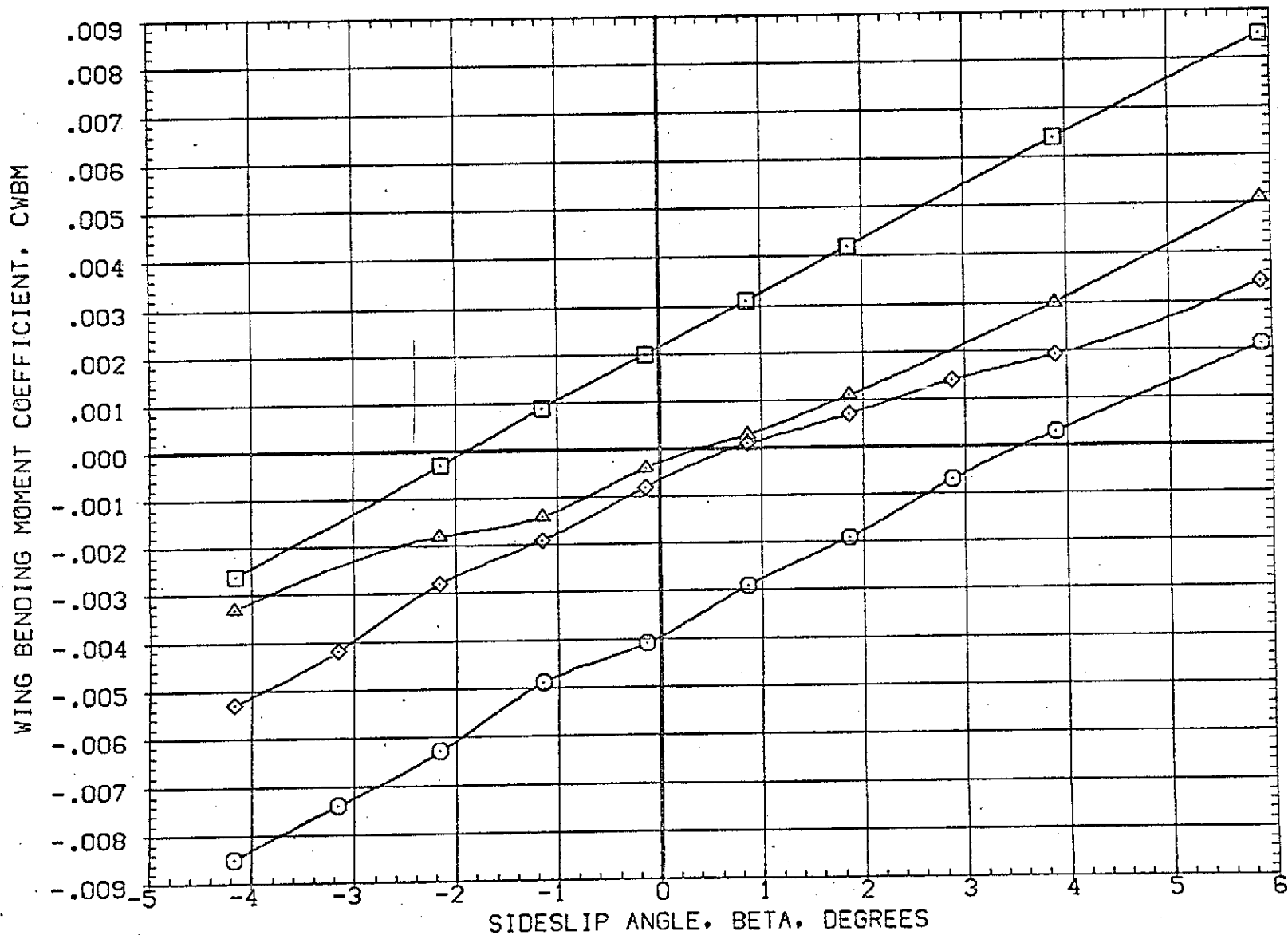

FIG 18 EFFECT OF PLUMES ON ELEVON AND RUDDER POWER, ALPHA=0.0

(A)MACH = 1.60

DATA SET SYMBOL	CONFIGURATION DESCRIPTION	ELEVON	AILERON	RUDDER	PLUMES	REFERENCE INFORMATION		
(RBJ502)	AMES 97-616 1A2 01 TO S1 NO PLUMES	.000	.000	.000	.000	SREF	3155.0000	50. FT.
(RBJ512)	AMES 97-616 1A2 01 TO S1 NO PLUMES	10.000	.000	10.000	.000	LREF	50.8000	FT.
(SBJ002)	AMES 97-616 1A2 01 TO S1 PC/PT-NOM.SRM A/A=8	.000	.000	.000	5.000	BREF	73.5000	FT.
(RBJ012)	AMES 97-616 1A2 01 TO S1 PC/PT-NOM.SRM A/A=8	10.000	.000	10.000	5.000	XMRP	86.4167	FT.
						YMRP	.0000	FT.
						ZMRP	4.0000	FT.
						SCALE	.0190	

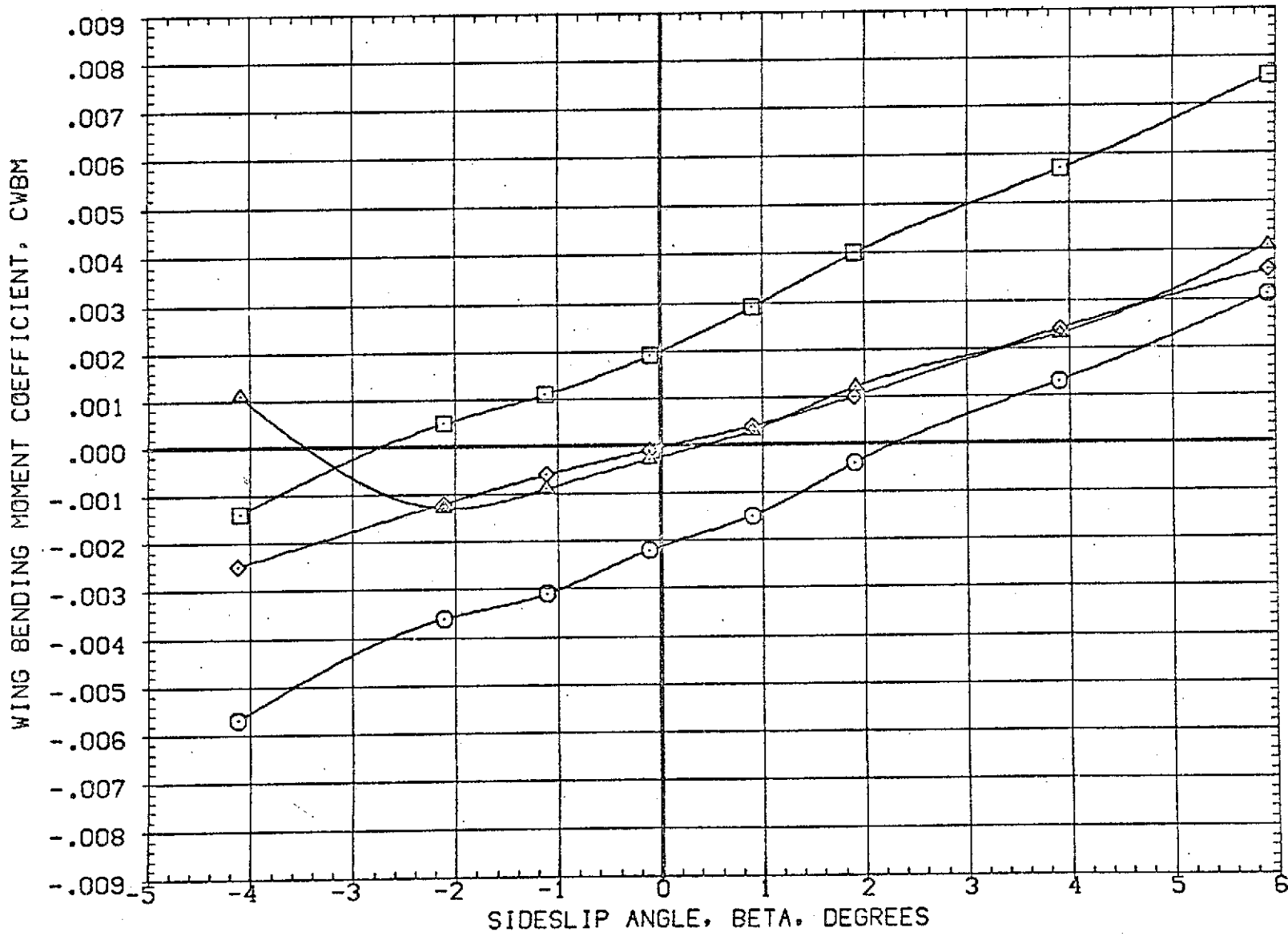

FIG 18 EFFECT OF PLUMES ON ELEVON AND RUDDER POWER, ALPHA=0.0

(B)MACH = 1.98

DATA SET SYMBOL	CONFIGURATION DESCRIPTION	ELEVON	AILRON	RUDDER	PLUMES	REFERENCE INFORMATION	
(RBJS02)	AMES 97-616 1A2 01 TO S1 NO PLUMES	.000	.000	.000	.000	SREF	3155.0000 SQ.FT.
(RBJS12)	AMES 97-616 1A2 01 TO S1 NO PLUMES	10.000	.000	10.000	.000	LREF	50.8000 FT.
(SBJ002)	AMES 97-616 1A2 01 TO S1 PC/PT NOM.SRM A/A=8	.000	.000	.000	5.000	BREF	73.5000 FT.
(RBJO12)	AMES 97-616 1A2 01 TO S1 PC/PT=NOM.SRM A/A=8	10.000	.000	10.000	5.000	XMRP	86.4167 FT.
						YMRP	.0000 FT.
						ZMRP	4.0000 FT.
						SCALE	.0190

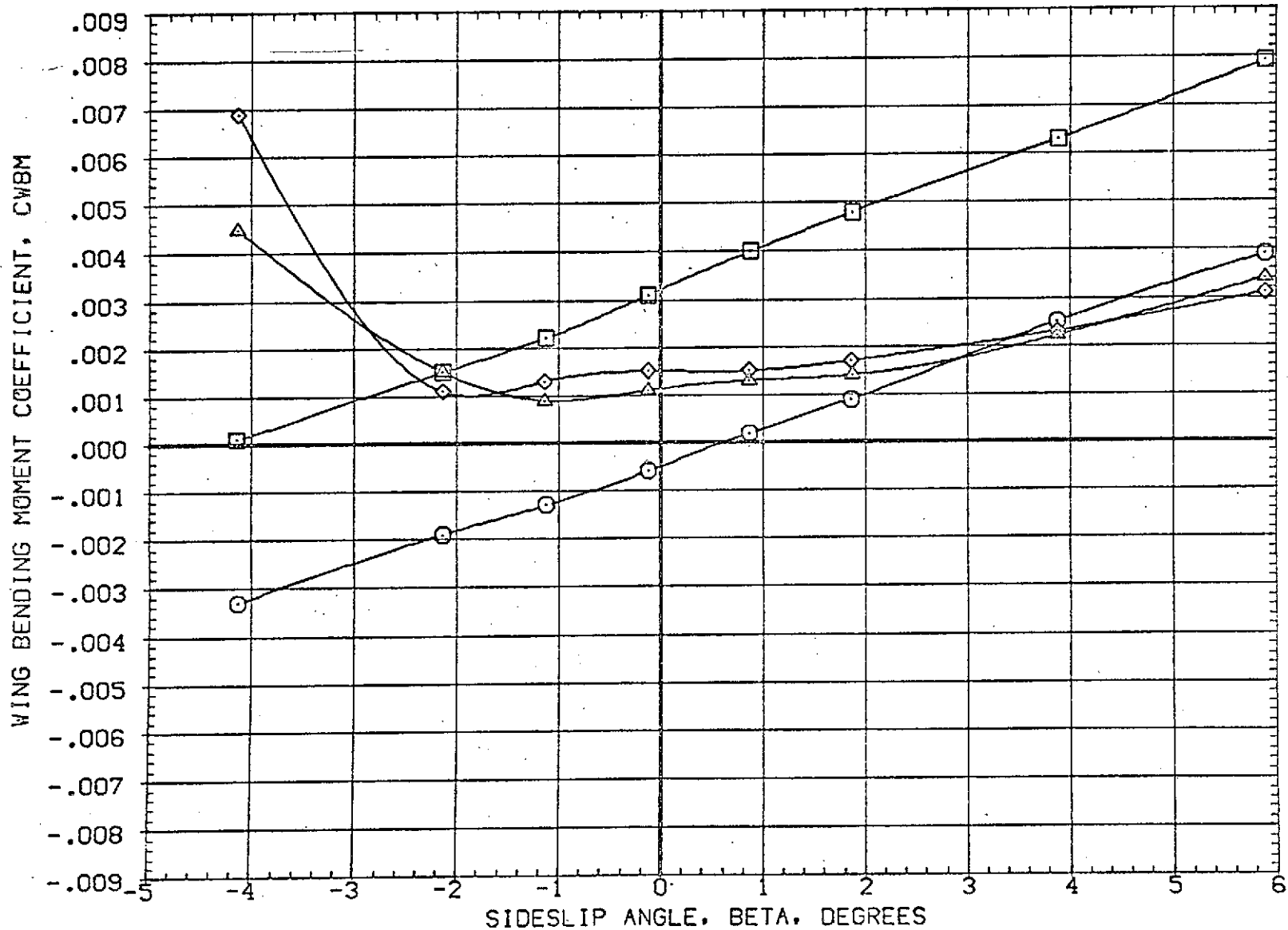

FIG 18 EFFECT OF PLUMES ON ELEVON AND RUDDER POWER, ALPHA=0.0

DATA SET SYMBOL	CONFIGURATION DESCRIPTION	ELEVON	AILRON	RUDDER	PLUMES	REFERENCE INFORMATION	
(RBJS02)	AMES 97-616 1A2 01 TO S1 NO PLUMES	.000	.000	.000	.000	SREF	3155.0000 SQ.FT.
(RBJS12)	AMES 97-616 1A2 01 TO S1 NO PLUMES	10.000	.000	10.000	.000	LREF	50.8000 FT.
(SBJ002)	AMES 97-616 1A2 01 TO S1 PC/PT-NOM.SRM A/A-8	.000	.000	.000	5.000	BREF	73.5000 FT.
(SBJ012)	AMES 97-616 1A2 01 TO S1 PC/PT-NOM.SRM A/A-8	10.000	.000	10.000	5.000	XMRP	86.4167 FT.
						YMRP	.0000 FT.
						ZMRP	4.0000 FT.
						SCALE	.0190

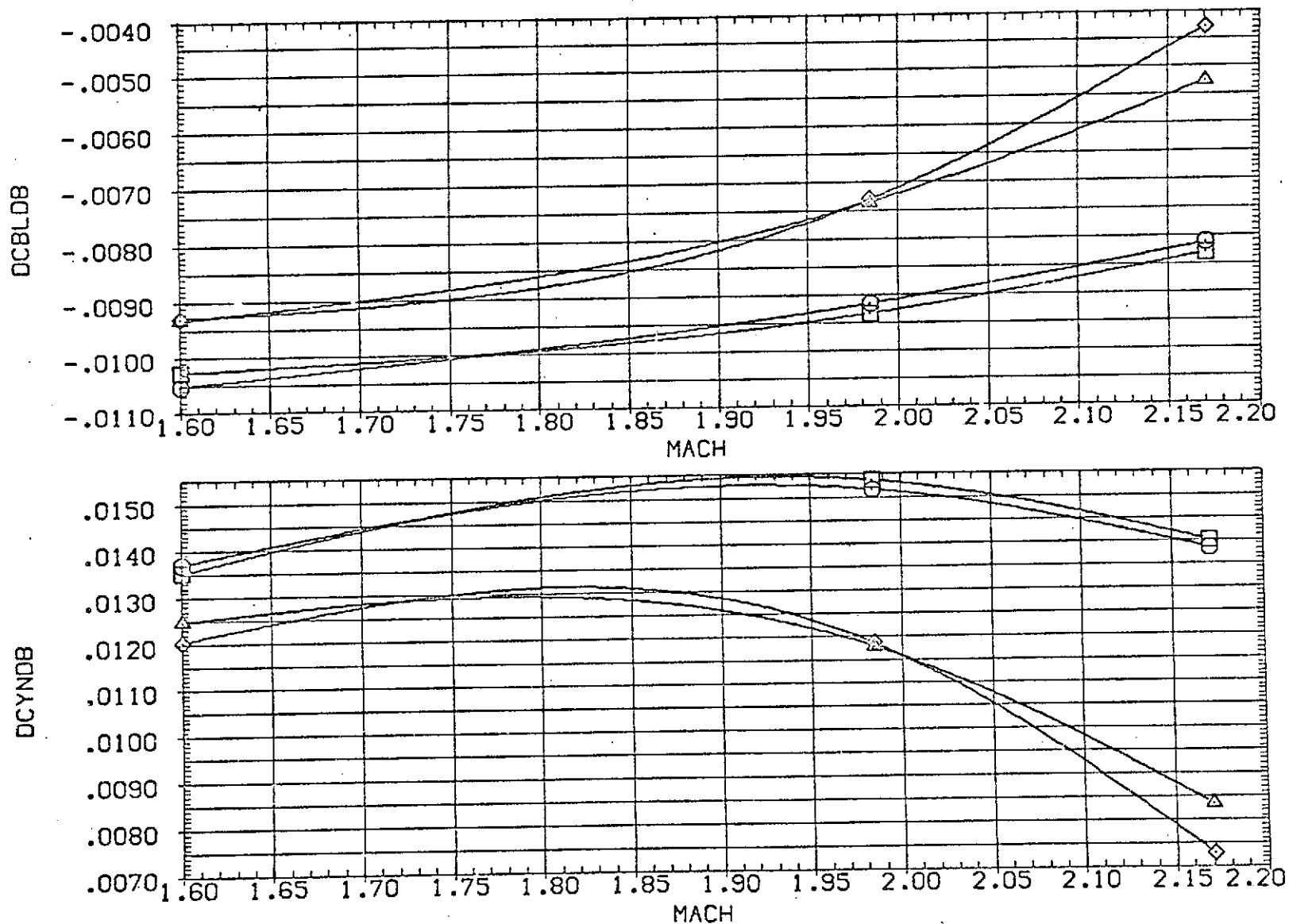

FIG 18 EFFECT OF PLUMES ON ELEVON AND RUDDER POWER, ALPHA=0.0

DATA SET SYMBOL	CONFIGURATION DESCRIPTION	ELEVON	AILRON	RUDDER	PLUMES	REFERENCE INFORMATION	
(RBJ522)	AMES 97-616 1A2 01 TO S1 NO PLUMES	.000	10.000	.000	.000	SREF	3155.0000 SQ.FT.
(RBJ022)	AMES 97-616 1A2 01 TO S1 PC/PT=NDM SRM A/A-8	.000	10.000	.000	5.000	LREF	50.8000 FT.
(RBJ024)	AMES 97-616 1A2 01 TO S1 SRM A/A-12,ORB NDM	.000	10.000	.000	5.000	BREF	73.5000 FT.
						XMRP	86.4167 FT.
						YMRP	.0000 FT.
						ZMRP	4.0000 FT.
						SCALE	.0190

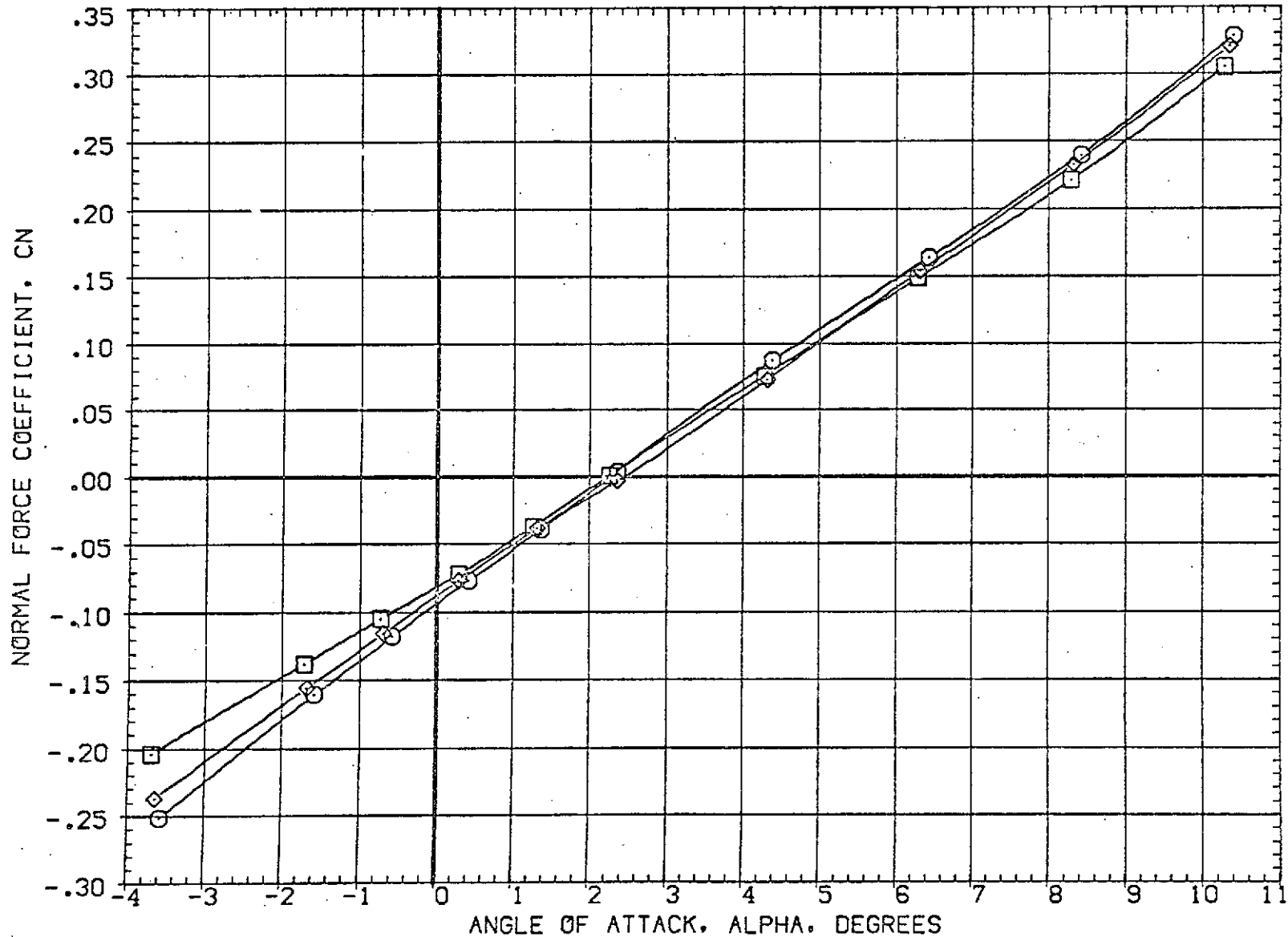

FIG 19 EFFECT OF PLUMES ON AILERON POWER, BETA=0.0

(A)MACH = 1.98

DATA SET SYMBOL	CONFIGURATION DESCRIPTION	ELEVON	AILERON	RUDDER	PLUMES	REFERENCE INFORMATION
(RBJ522)	AMES 97-616 IA2 01 TO S1 NO PLUMES	.000	10.000	.000	.000	SREF 3155.0000 SQ.FT.
(RBJ022)	AMES 97-616 IA2 01 TO S1 PC/PT=NOM SRM A/A=8	.000	10.000	.000	5.000	LREF 50.8000 FT.
(RBJ024)	AMES 97-616 IA2 01 TO S1 SRM A/A=12.0RB NOM	.000	10.000	.000	5.000	BREF 73.5000 FT.
						XMRP 86.4167 FT.
						YMRP .0000 FT.
						ZMRP 4.0000 FT.
						SCALE .0190

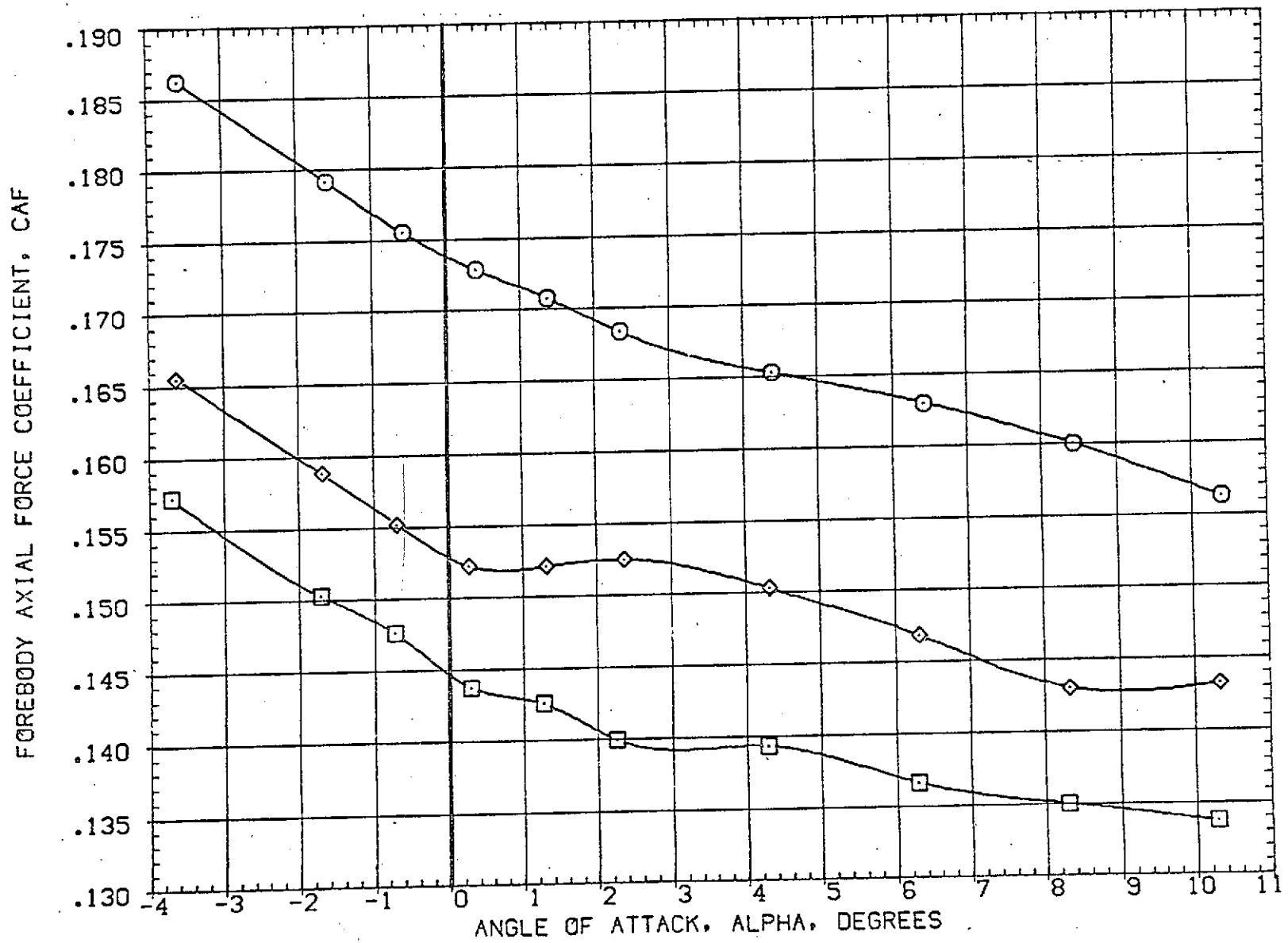

FIG 19 EFFECT OF PLUMES ON AILERON POWER, BETA=0.0

(A)MACH = 1.98

DATA SET SYMBOL	CONFIGURATION DESCRIPTION	ELEVON	AILERON	RUDDER	PLUMES	REFERENCE INFORMATION
(RBJ522)	○ AMES 97-616 1A2 01 TO S1 NO PLUMES	.000	10.000	.000	.000	SREF 3155.0000 SQ.FT.
(RBJ022)	□ AMES 97-616 1A2 01 TO S1 PC/PT=NOM SRM A/A=8	.000	10.000	.000	5.000	LREF 50.8000 FT.
(RBJ024)	◇ AMES 97-616 1A2 01 TO S1 SRM A/A=12.0RB NOM	.000	10.000	.000	5.000	BREF 73.5000 FT. XMRP 86.4167 FT. YMRP .0000 FT. ZMRP 4.0000 FT. SCALE .0190

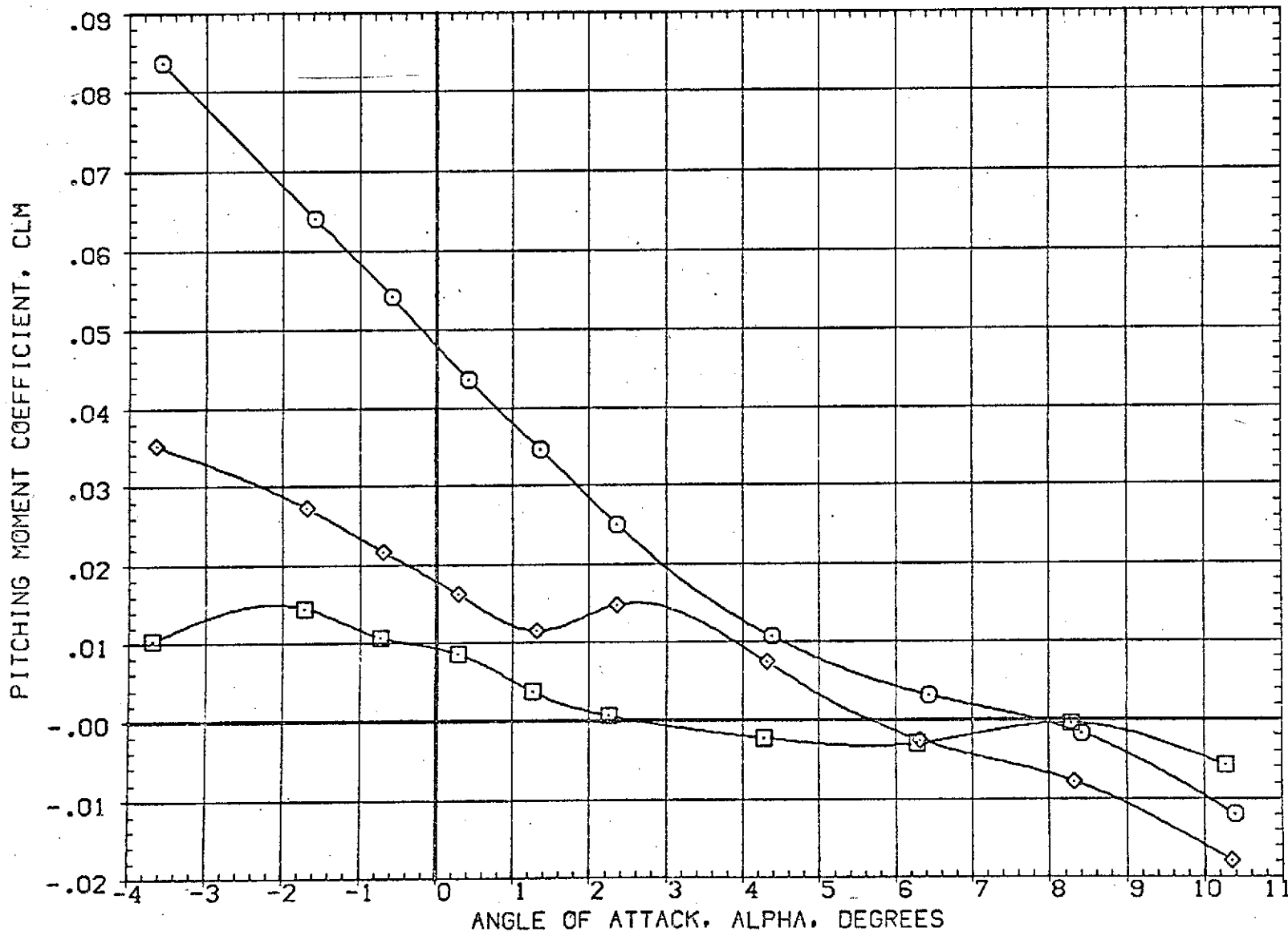

FIG 19 EFFECT OF PLUMES ON AILERON POWER, BETA=0.0

(A)MACH. = 1.98

DATA SET SYMBOL	CONFIGURATION DESCRIPTION	ELEVON	AILRON	RUDDER	PLUMES	REFERENCE INFORMATION		
(RBJ522)	○ AMES 97-616 IA2 01 TO S1 NO PLUMES	.000	10.000	.000	.000	SREF	3155.0000	SG.FT.
(RBJ022)	□ AMES 97-616 IA2 01 TO S1 PC/PT-NOM SRM A/A=8	.000	10.000	.000	5.000	LREF	50.8000	FT.
(RBJ024)	◇ AMES 97-616 IA2 01 TO S1 SRM A/A=12.0RB NOM	.000	10.000	.000	5.000	BREF	73.5000	FT.
						XMRP	86.4167	FT.
						YMRP	.0000	FT.
						ZMRP	4.0000	FT.
						SCALE	.0190	

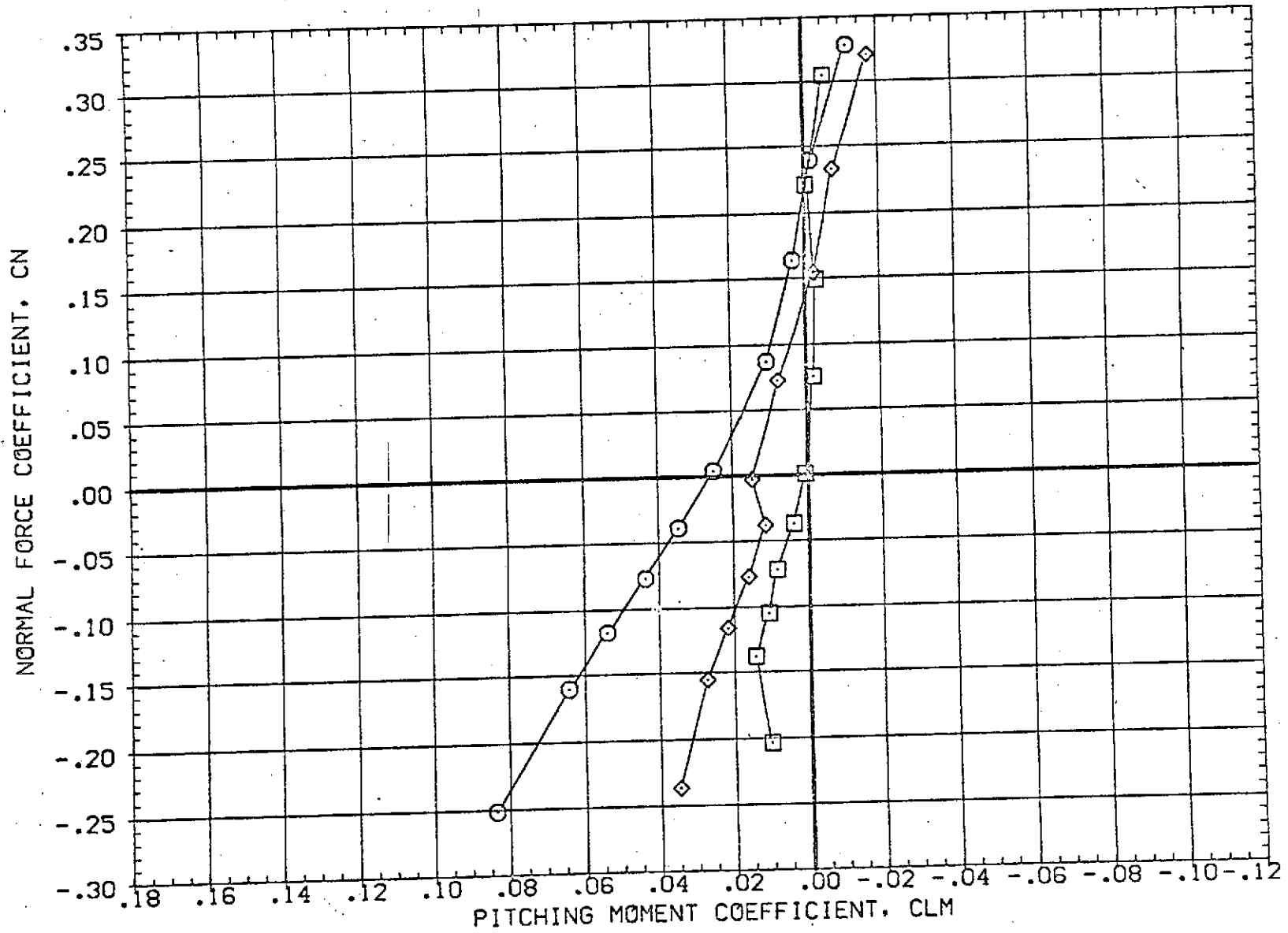

FIG 19 EFFECT OF PLUMES ON AILERON POWER, BETA=0.0

(A)MACH = 1.98

DATA SET SYMBOL	CONFIGURATION DESCRIPTION	ELEVON	AILRON	RUDDER	PLUMES	REFERENCE INFORMATION
(RBJ522)	AMES 97-616 IA2 01 TO S1 NO PLUMES	.000	10.000	.000	.000	SREF 3155.0000 SQ.FT.
(RBJ022)	AMES 97-616 IA2 01 TO S1 PC/PT=NOM SRM A/A=8	.000	10.000	.000	5.000	LREF 50.8000 FT.
(RBJ024)	AMES 97-616 IA2 01 TO S1 SRM A/A=12,CRB NOM	.000	10.000	.000	5.000	BREF 73.5000 FT.
						XMRP 86.4167 FT.
						YMRP .0000 FT.
						ZMRP 4.0000 FT.
						SCALE .0190

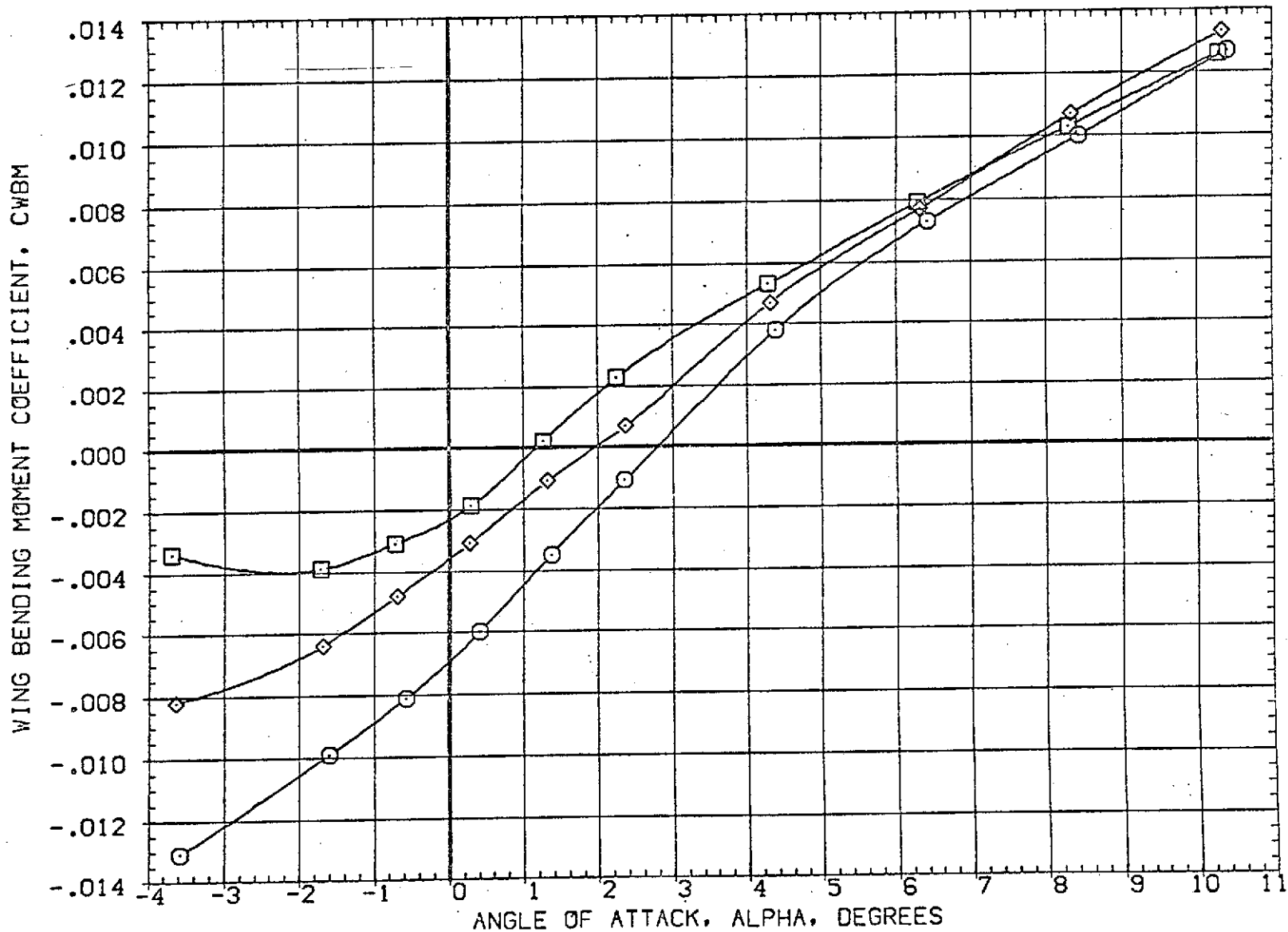

FIG 19 EFFECT OF PLUMES ON AILERON POWER, BETA=0.0

(A)MACH = 1.98

DATA SET SYMBOL	CONFIGURATION DESCRIPTION	ELEVON	AILRON	RUDDER	PLUMES	REFERENCE INFORMATION
(RBJ522)	AMES 97-616 1A2 01 TO S1 NO PLUMES	.000	10.000	.000	.000	SREF 3155.0000 SQ.FT.
(RBJ022)	AMES 97-616 1A2 01 TO S1 PC/PT=NDM SRM A/A=8	.000	10.000	.000	5.000	LREF 50.8000 FT.
(RBJ024)	AMES 97-616 1A2 01 TO S1 SRM A/A=12.0RB NDM	.000	10.000	.000	5.000	BREF 73.5000 FT.
						XMRP 86.4167 FT.
						YMRP .0000 FT.
						ZMRP 4.0000 FT.
						SCALE .0190

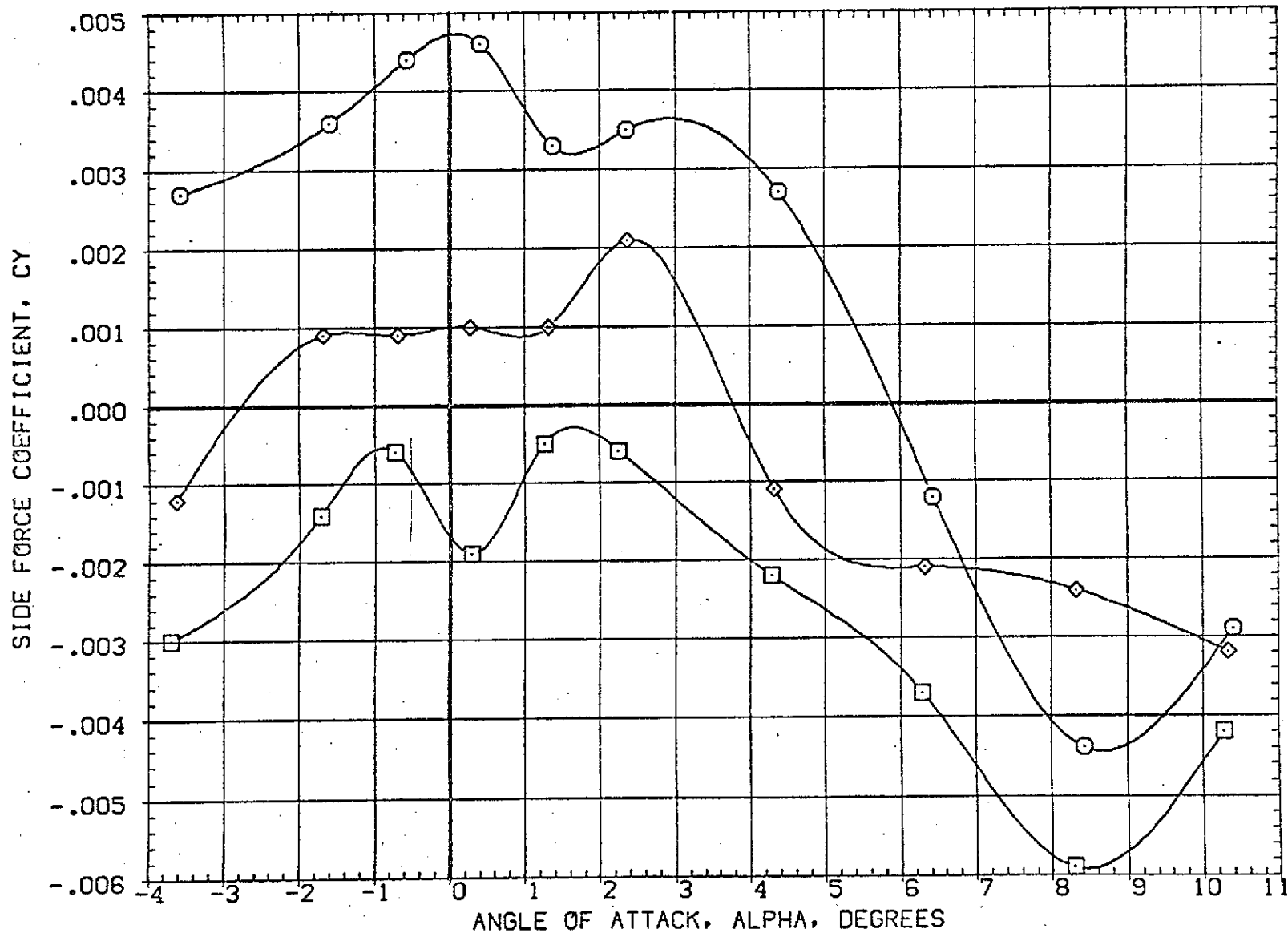

FIG 19 EFFECT OF PLUMES ON AILERON POWER, BETA=0.0

(A)MACH = 1.98

DATA SET SYMBOL	CONFIGURATION DESCRIPTION	ELEVON	AILRON	RUDDER	PLUMES	REFERENCE INFORMATION
(RBJ522)	AMES 97-616 1A2 01 TO S1 NO PLUMES	.000	10.000	.000	.000	SREF 3155.0000 SQ.FT.
(RBJ022)	AMES 97-616 1A2 01 TO S1 PC/PT=NDM SRM A/A=8	.000	10.000	.000	5.000	LREF 50.8000 FT.
(RBJ024)	AMES 97-616 1A2 01 TO S1 SRM A/A=12.0RB NDM	.000	10.000	.000	5.000	BREF 73.5000 FT. XMRP 66.4167 FT. YMRP .0000 FT. ZMRP 4.0000 FT. SCALE .0190

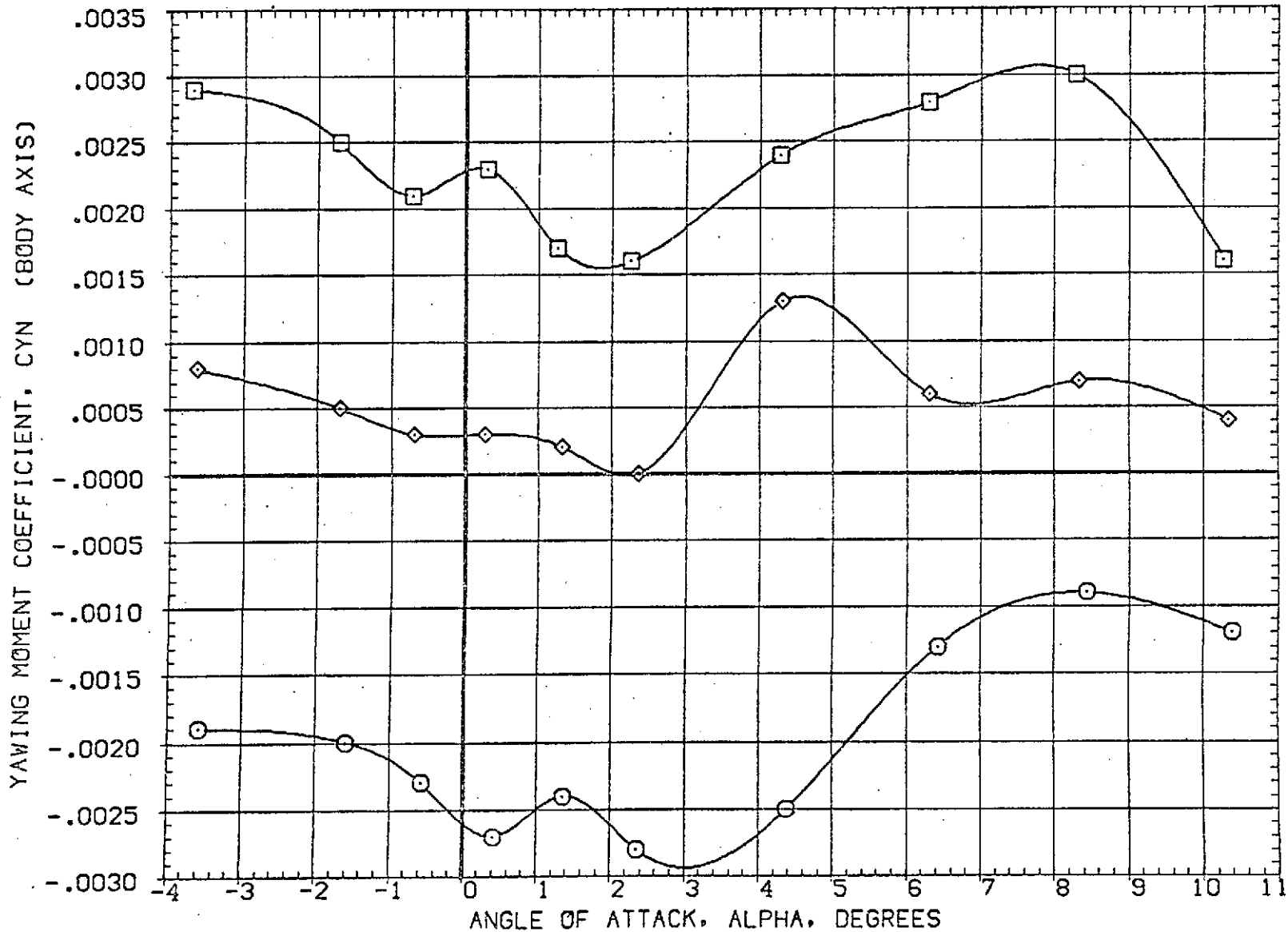

FIG 19 EFFECT OF PLUMES ON AILERON POWER, $\beta = 0.0$

(A)MACH = 1.98

DATA SET SYMBOL	CONFIGURATION DESCRIPTION	ELEVON	AILRON	RUDDER	PLUMES	REFERENCE INFORMATION	
(RBJ522)	AMES 97-616 IA2 01 TO S1 NO PLUMES	.000	10.000	.000	.000	SREF	3155.0000 SQ.FT.
(RBJ022)	AMES 97-616 IA2 01 TO S1 PC/PT=NOM SRM A/A=8	.000	10.000	.000	5.000	LREF	50.8000 FT.
(RBJ024)	AMES 97-616 IA2 01 TO S1 SRM A/A=12.0RB NOM	.000	10.000	.000	5.000	BREF	73.5000 FT.
						XMRP	86.4167 FT.
						YMRP	.0000 FT.
						ZMRP	4.0000 FT.
						SCALE	.0190

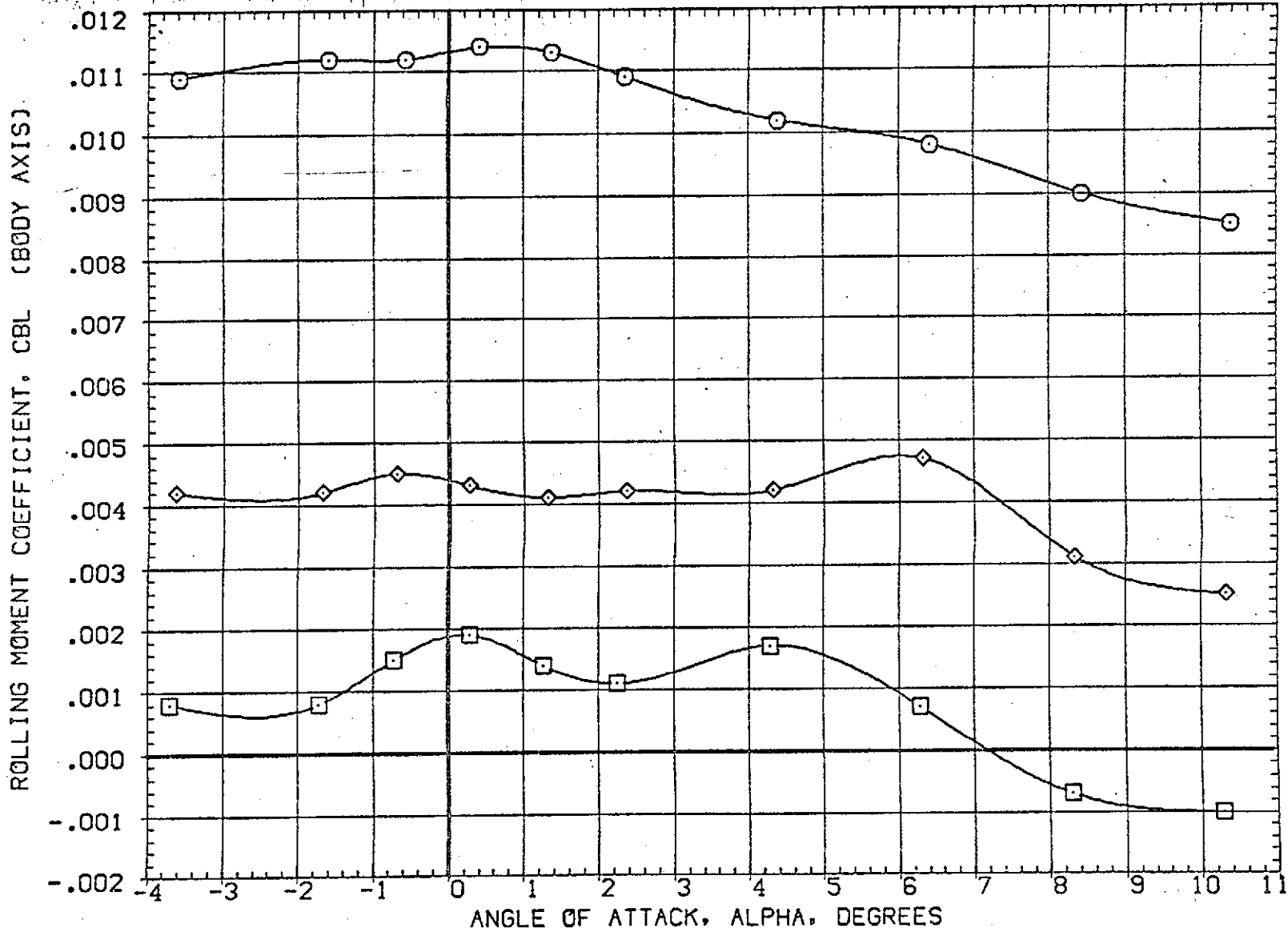

FIG 19 EFFECT OF PLUMES ON AILERON POWER, BETA=0.0

(A)MACH = 1.98

DATA SET SYMBOL	CONFIGURATION DESCRIPTION	ELEVON	AILRON	RUDDER	PLUMES	REFERENCE INFORMATION	
(DBJ502)	AMES 97-616 1A2 01 TO S1 NO PLUMES	.000	.000	.000	.000	SREF	3155.0000 SQ.FT.
(RBJ523)	AMES 97-616 1A2 01 TO S1 NO PLUMES	.000	10.000	.000	.000	LREF	50.8000 FT.
(HBJ002)	AMES 97-616 1A2 01 TO S1 PC/PT NOM SRM A/A-8	.000	.000	.000	5.000	BREF	73.5000 FT.
(RBJ023)	AMES 97-616 1A2 01 TO S1 PC/PT NOM SRM A/A-8	.000	10.000	.000	5.000	XMRP	86.4167 FT.
						YMRP	.0000 FT.
						ZMRP	4.0000 FT.
						SCALE	.0190

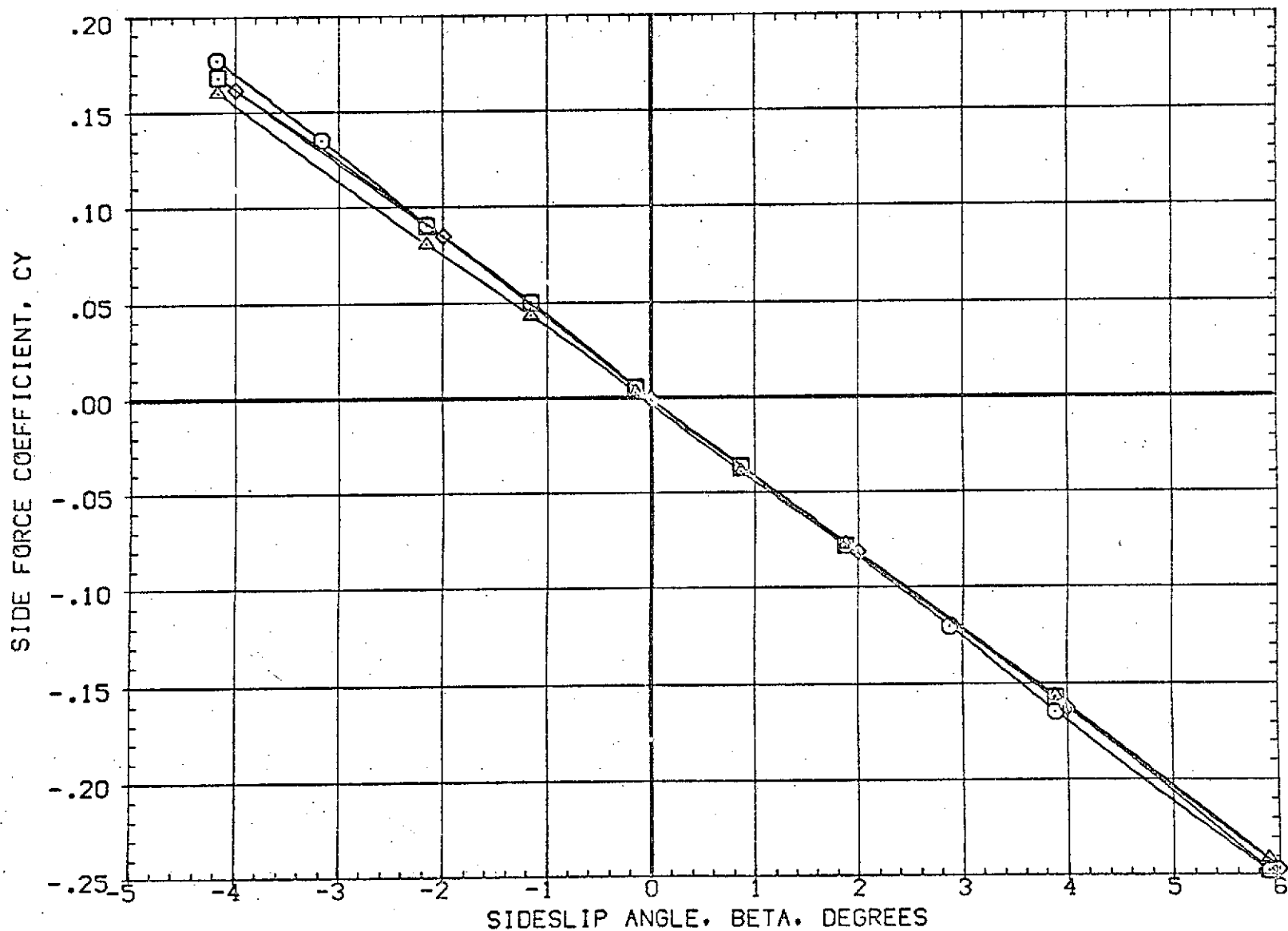

FIG 20 EFFECT OF PLUMES ON AILERON POWER, ALPHA=0.0

(A)MACH = 1.60

DATA SET SYMBOL	CONFIGURATION DESCRIPTION	ELEVON	AILRON	RUDDER	PLUMES
(DBJ502)	AMES 97-616 IA2 01 TO S1 NO PLUMES	.000	.000	.000	.000
(DBJ523)	AMES 97-616 IA2 01 TO S1 NO PLUMES	.000	10.000	.000	.000
(FBJ002)	AMES 97-616 IA2 01 TO S1 PC/PT NOM SRM A/A=8	.000	.000	.000	5.000
(FBJ023)	AMES 97-616 IA2 01 TO S1 PC/PT NOM SRM A/A=8	.000	10.000	.000	5.000

REFERENCE INFORMATION		
SREF	3155.0000	SQ.FT.
LREF	50.8000	FT.
BREF	73.5000	FT.
XM RP	86.4167	FT.
YM RP	.0000	FT.
ZM RP	4.0000	FT.
SCALE	.0190	

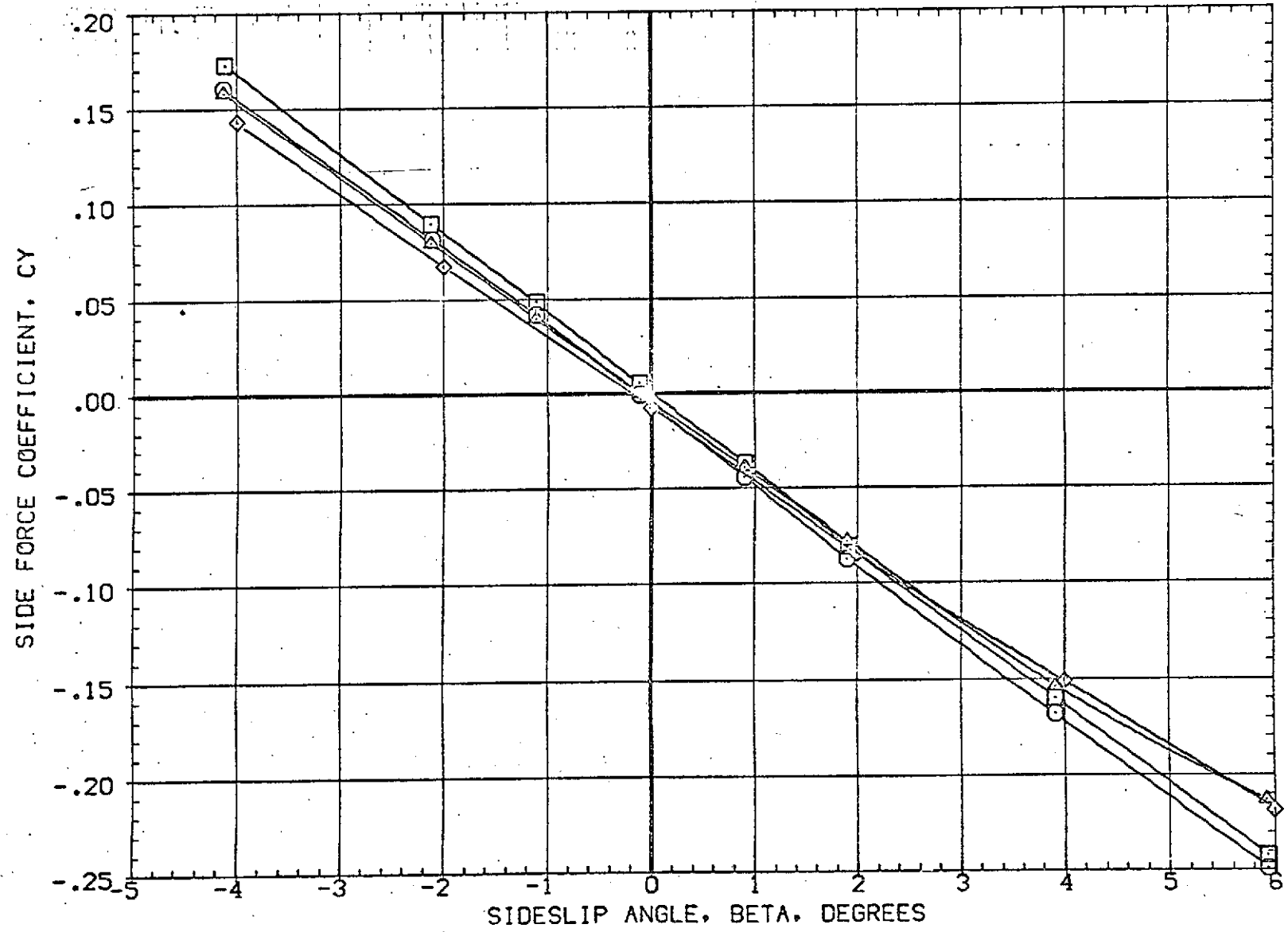

FIG 20 EFFECT OF PLUMES ON AILERON POWER, ALPHA=0.0

(B)MACH = 1.98

DATA SET SYMBOL	CONFIGURATION DESCRIPTION	ELEVON	AILRON	RUDDER	PLUMES	REFERENCE INFORMATION
(RBJ502)	AMES 97-616 [A2 01 TO S1 NO PLUMES	.000	.000	.000	.000	SREF 3155.0000 SQ.FT.
(RBJ523)	AMES 97-616 [A2 01 TO S1 NO PLUMES	.000	10.000	.000	.000	LREF 50.8000 FT.
(RBJ002)	AMES 97-616 [A2 01 TO S1 PC/PT NOM. SRM A/A=8	.000	.000	.000	5.000	BREF 73.5000 FT.
(RBJ023)	AMES 97-616 [A2 01 TO S1 PC/PT=NOM SRM A/A=8	.000	10.000	.000	5.000	XMRP 86.4167 FT.
						YMRP .0000 FT.
						ZMRP 4.0000 FT.
						SCALE .0190

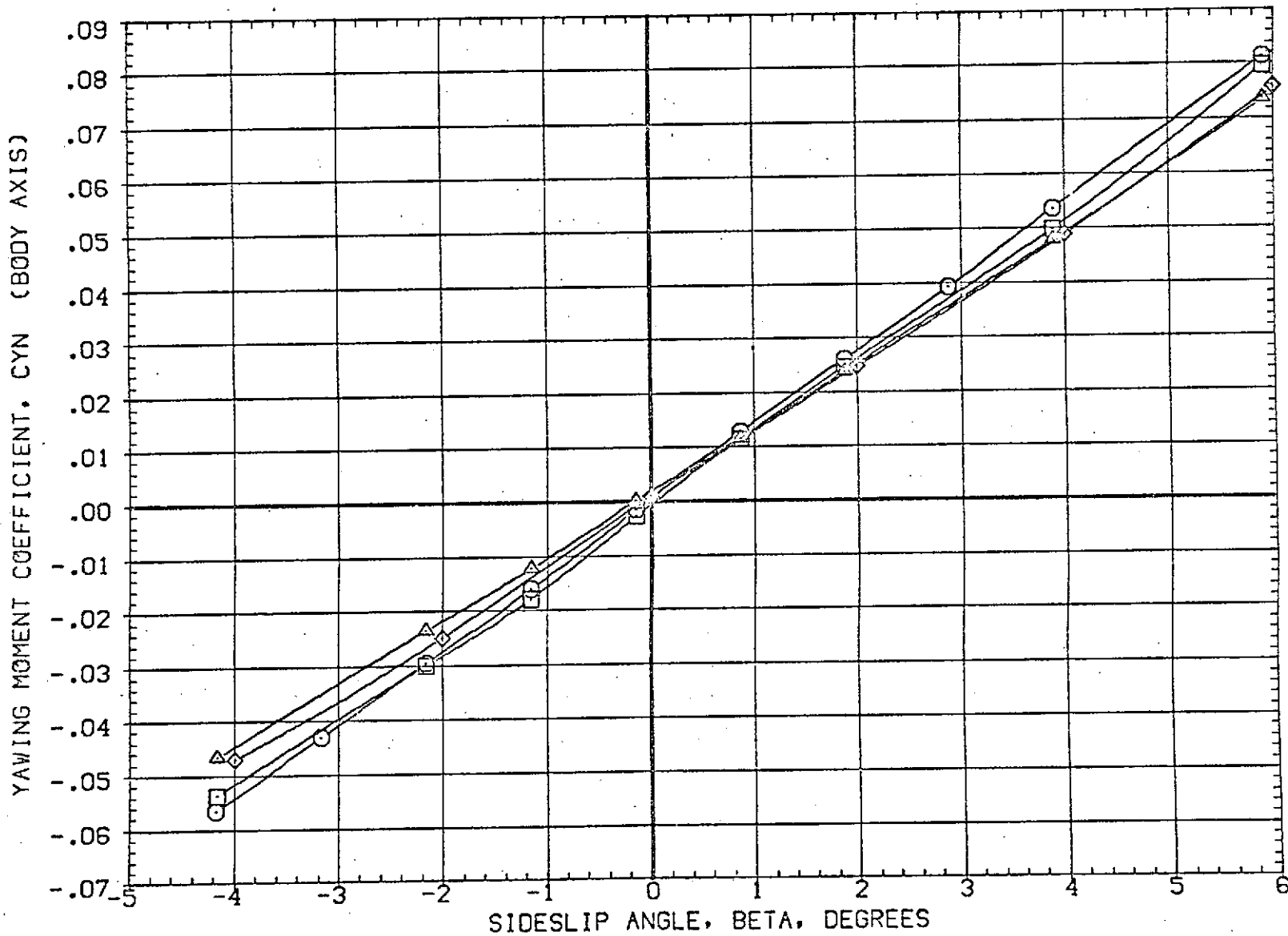

FIG 20 EFFECT OF PLUMES ON AILERON POWER, ALPHA=0.0

(A)MACH = 1.60

DATA SET SYMBOL	CONFIGURATION DESCRIPTION	ELEVON	AILERON	RUDDER	PLUMES
(OB)502)	AMES 97-616 IA2 01 TO S1 NO PLUMES	.000	.000	.000	.000
(RB)523)	AMES 97-616 IA2 01 TO S1 NO PLUMES	.000	10.000	.000	.000
(H)002)	AMES 97-616 IA2 01 TO S1 PC/PT-NOM SRM A/A-8	.000	.000	.000	5.000
(RB)023)	AMES 97-616 IA2 01 TO S1 PC/PT-NOM SRM A/A-8	.000	10.000	.000	5.000

REFERENCE INFORMATION		
SREF	3155.0000	50.FT.
LREF	50.8000	FT.
BREF	73.5000	FT.
XMRP	86.4167	FT.
YMRP	.0000	FT.
ZMRP	4.0000	FT.
SCALE	.0190	

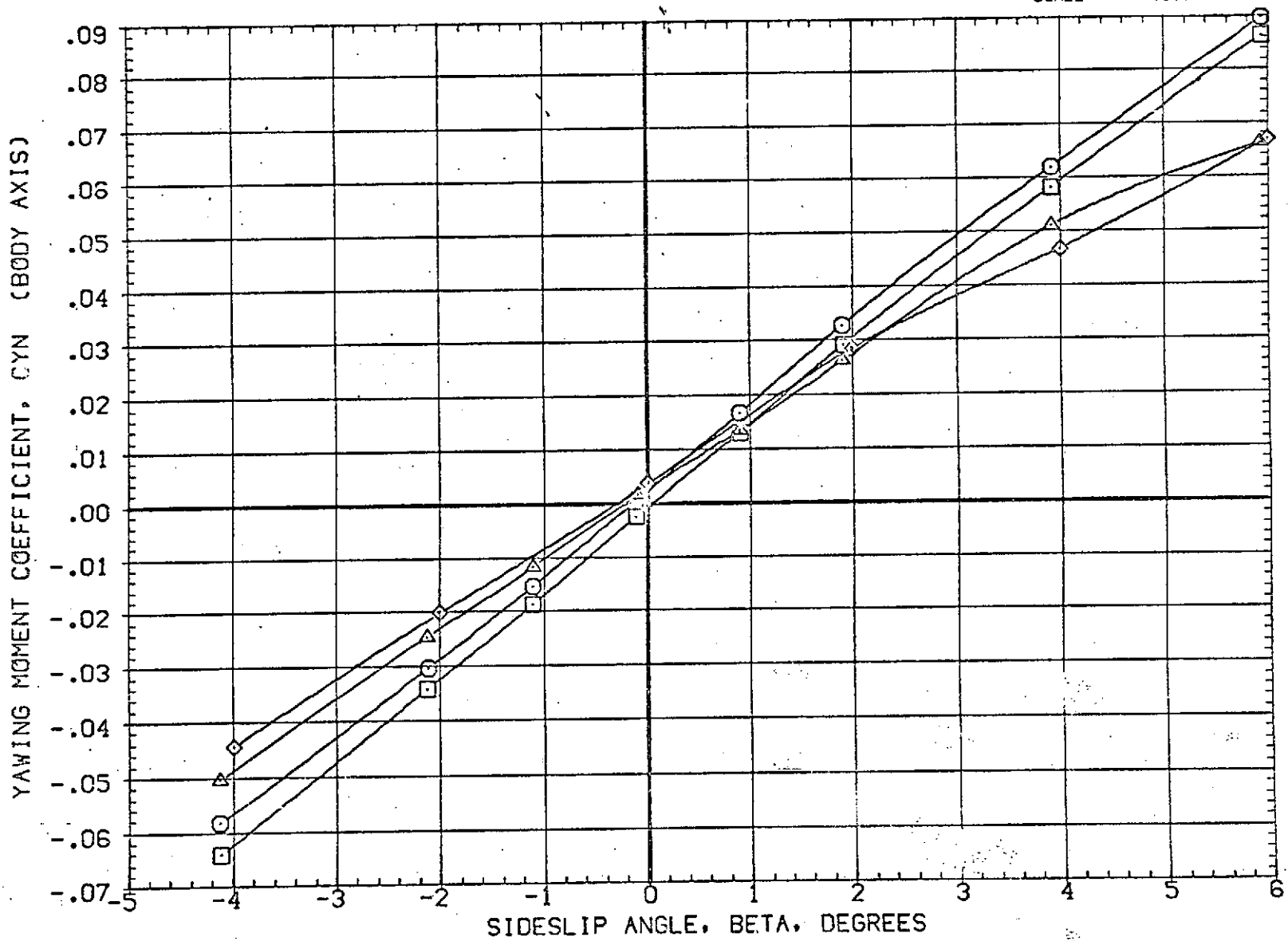

FIG 20 EFFECT OF PLUMES ON AILERON POWER, ALPHA=0.0

(B)MACH = 1.98

DATA SET SYMBOL	CONFIGURATION DESCRIPTION	ELEVON	AILRON	RUDDER	PLUMES	REFERENCE INFORMATION
(DBJ502)	AMES 97-616 1A2 01 TO S1 NO PLUMES	.000	.000	.000	.000	SREF 3155.0000 SQ.FT.
(RBJ523)	AMES 97-616 1A2 01 TO S1 NO PLUMES	.000	10.000	.000	.000	LREF 50.8000 FT.
(HBJ002)	AMES 97-616 1A2 01 TO S1 PC/PT-NOM.SRM A/A=8	.000	.000	.000	5.000	BREF 73.5000 FT.
(RBJ023)	AMES 97-616 1A2 01 TO S1 PC/PT-NOM SRM A/A=8	.000	10.000	.000	5.000	XMRP 86.4167 FT. YMRP .0000 FT. ZMRP 4.0000 FT. SCALE .0190

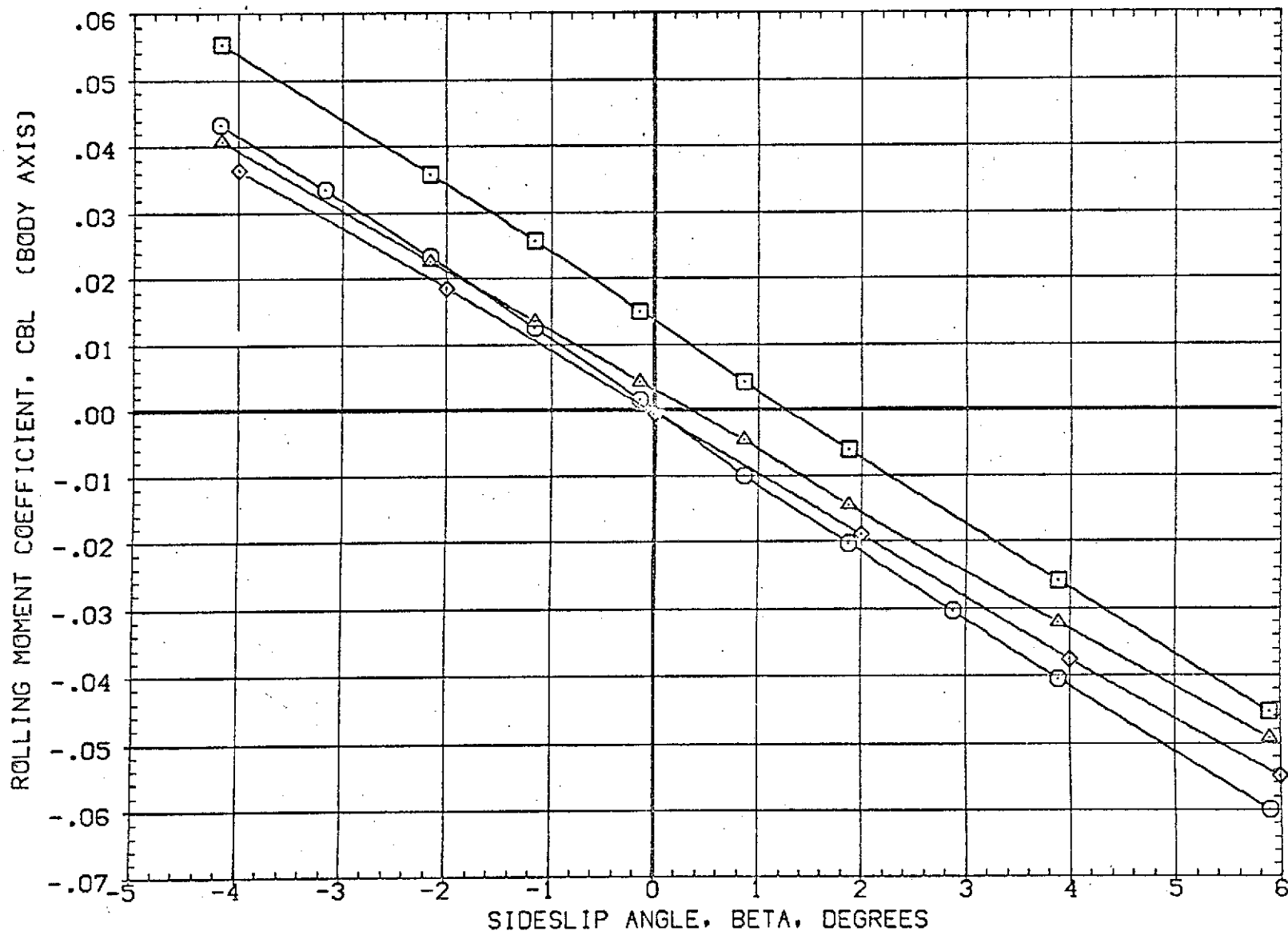

FIG 20 EFFECT OF PLUMES ON AILERON POWER, ALPHA=0.0

(A)MACH = 1.60

DATA SET	SYMBOL	CONFIGURATION DESCRIPTION
(RBJ502)	○	AMES 97-616 IA2 01 TO SI NO PLUMES
(RBJ523)	□	AMES 97-616 IA2 01 TO SI NO PLUMES
(HBJ002)	◇	AMES 97-616 IA2 01 TO SI PC/PT-NOM SRM A/A=8
(RBJ023)	△	AMES 97-616 IA2 01 TO SI PC/PT-NOM SRM A/A=8

ELEVON	AILRON	RUDDER	PLUMES	REFERENCE INFORMATION	
.000	.000	.000	.000	SREF	3155.0000 SQ.FT.
.000	10.000	.000	.000	LREF	50.8000 FT.
.000	.000	.000	5.000	BREF	73.5000 FT.
.000	10.000	.000	5.000	XMRP	86.4167 FT.
				YMRP	.0000 FT.
				ZMRP	4.0000 FT.
				SCALE	.0190

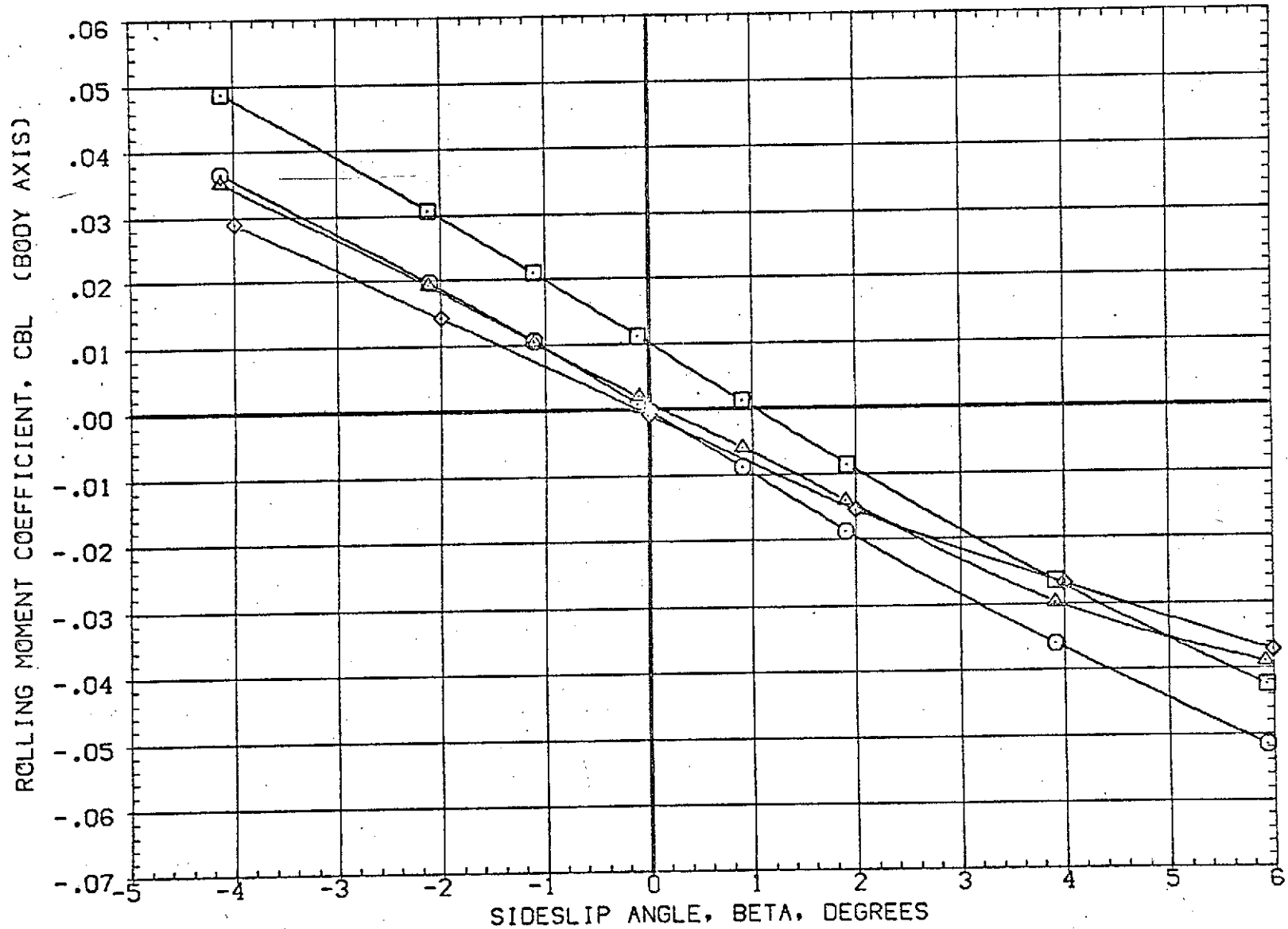

FIG 20 EFFECT OF PLUMES ON AILERON POWER, ALPHA=0.0

(B)MACH = 1.98

DATA SET SYMBOL	CONFIGURATION DESCRIPTION	ELEVON	AILRON	RUDDER	PLUMES	REFERENCE INFORMATION	
(RBJS02)	AMES 97-616 1A2 01 TO S1 NO PLUMES	.000	.000	.000	.000	SREF	3155.0000 SO.FT.
(RBJS23)	AMES 97-616 1A2 01 TO S1 NO PLUMES	.000	10.000	.000	.000	LREF	50.8000 FT.
(HBJS02)	AMES 97-616 1A2 01 TO S1 PC/PT NCM, SRM A/A=8	.000	.000	.000	5.000	BREF	73.5000 FT.
(RBJS023)	AMES 97-616 1A2 01 TO S1 PC/PT=NDM SRM A/A=8	.000	10.000	.000	5.000	XMRP	86.4167 FT.
						YMRP	.0000 FT.
						ZMRP	4.0000 FT.
						SCALE	.0190

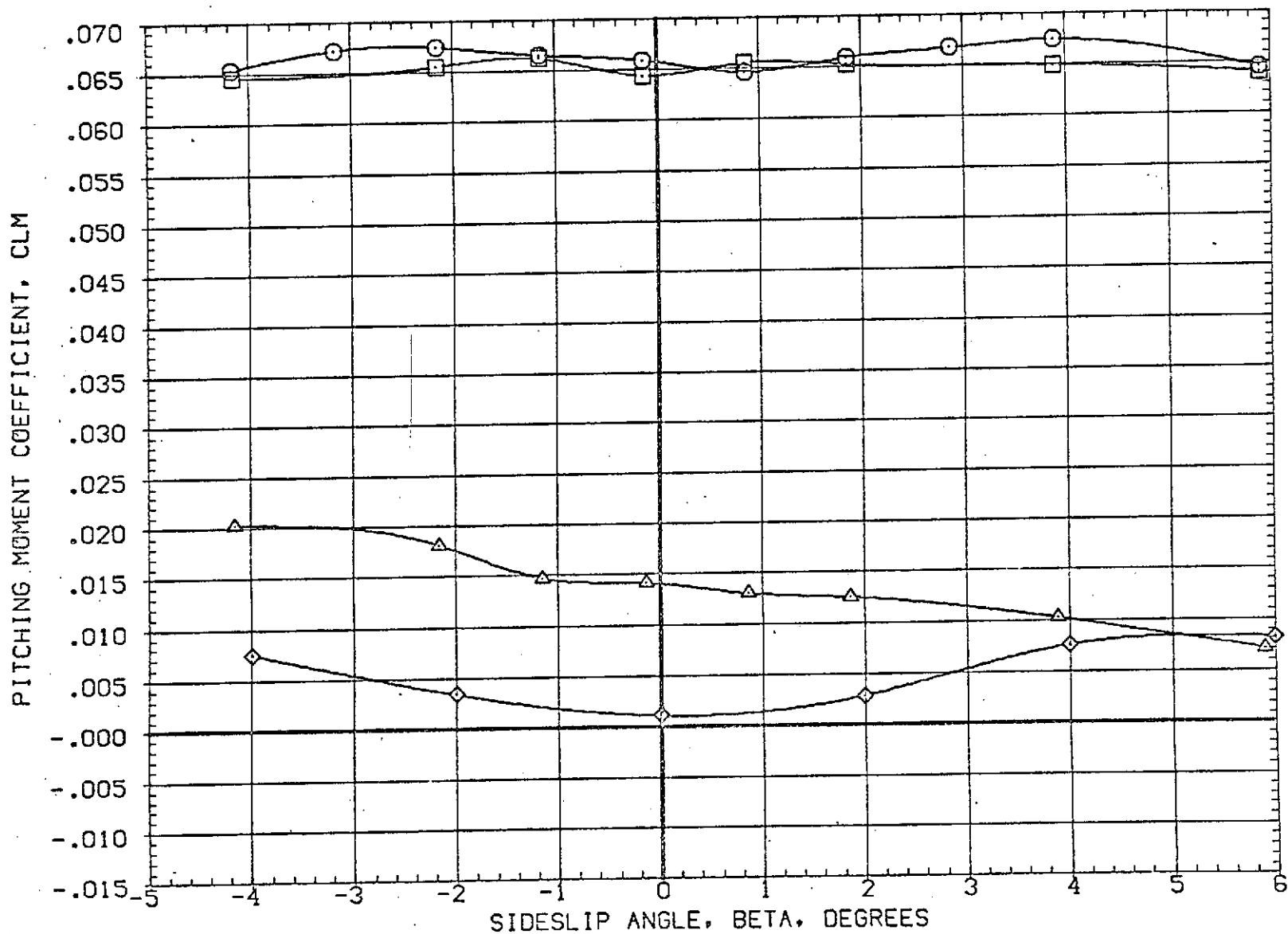

FIG 20 EFFECT OF PLUMES ON AILERON POWER, ALPHA=0.0

(A)MACH = 1.60

DATA SET SYMBOL	CONFIGURATION DESCRIPTION	ELEVON	AILRON	RUDDER	PLUMES	REFERENCE INFORMATION
(DBJ502)	AMES 97-616 1A2 01 TO S1 NO PLUMES	.000	.000	.000	.000	SREF 3155.0000 SQ.FT.
(RBJ523)	AMES 97-616 1A2 01 TO S1 NO PLUMES	.000	10.000	.000	.000	LREF 50.8000 FT.
(HBJ002)	AMES 97-616 1A2 01 TO S1 PC/PT-NOM. SRM A/A=8	.000	.000	.000	5.000	BREF 73.5000 FT.
(RBJ023)	AMES 97-616 1A2 01 TO S1 PC/PT-NOM. SRM A/A=8	.000	10.000	.000	5.000	XMRP 86.4167 FT.
						YMRP .0000 FT.
						ZMRP 4.0000 FT.
						SCALE .0190

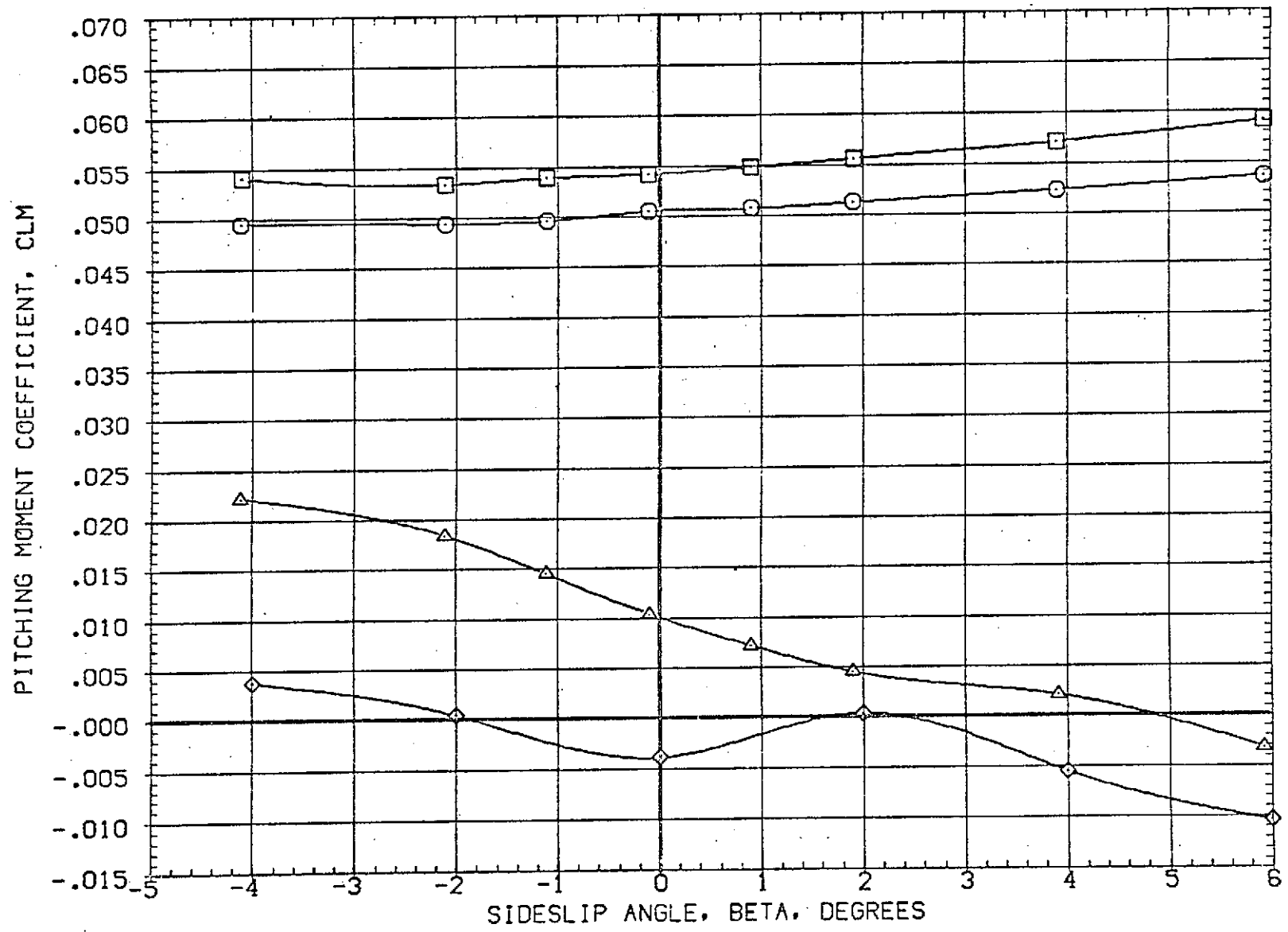

FIG 20 EFFECT OF PLUMES ON AILERON POWER, ALPHA=0.0

(B)MACH = 1.98

DATA SET SYMBOL	CONFIGURATION DESCRIPTION	ELEVON	AILRON	RUDDER	PLUMES	REFERENCE INFORMATION	
(OBJ502)	AMES 97-616 1A2 01 TO S1 NO PLUMES	.000	.000	.000	.000	SREF	3155.0000 SQ.FT.
(RBJ523)	AMES 97-616 1A2 01 TO S1 NO PLUMES	.000	10.000	.000	.000	LREF	50.8000 FT.
(HBJ002)	AMES 97-616 1A2 01 TO S1 PC/PT NOM. SRM A/A=8	.000	.000	.000	5.000	BREF	73.5000 FT.
(RBJ023)	AMES 97-616 1A2 01 TO S1 PC/PT-NOM SRM A/A=8	.000	10.000	.000	5.000	XMRP	86.4167 FT.
						YMRP	.0000 FT.
						ZMRP	4.0000 FT.
						SCALE	.0190

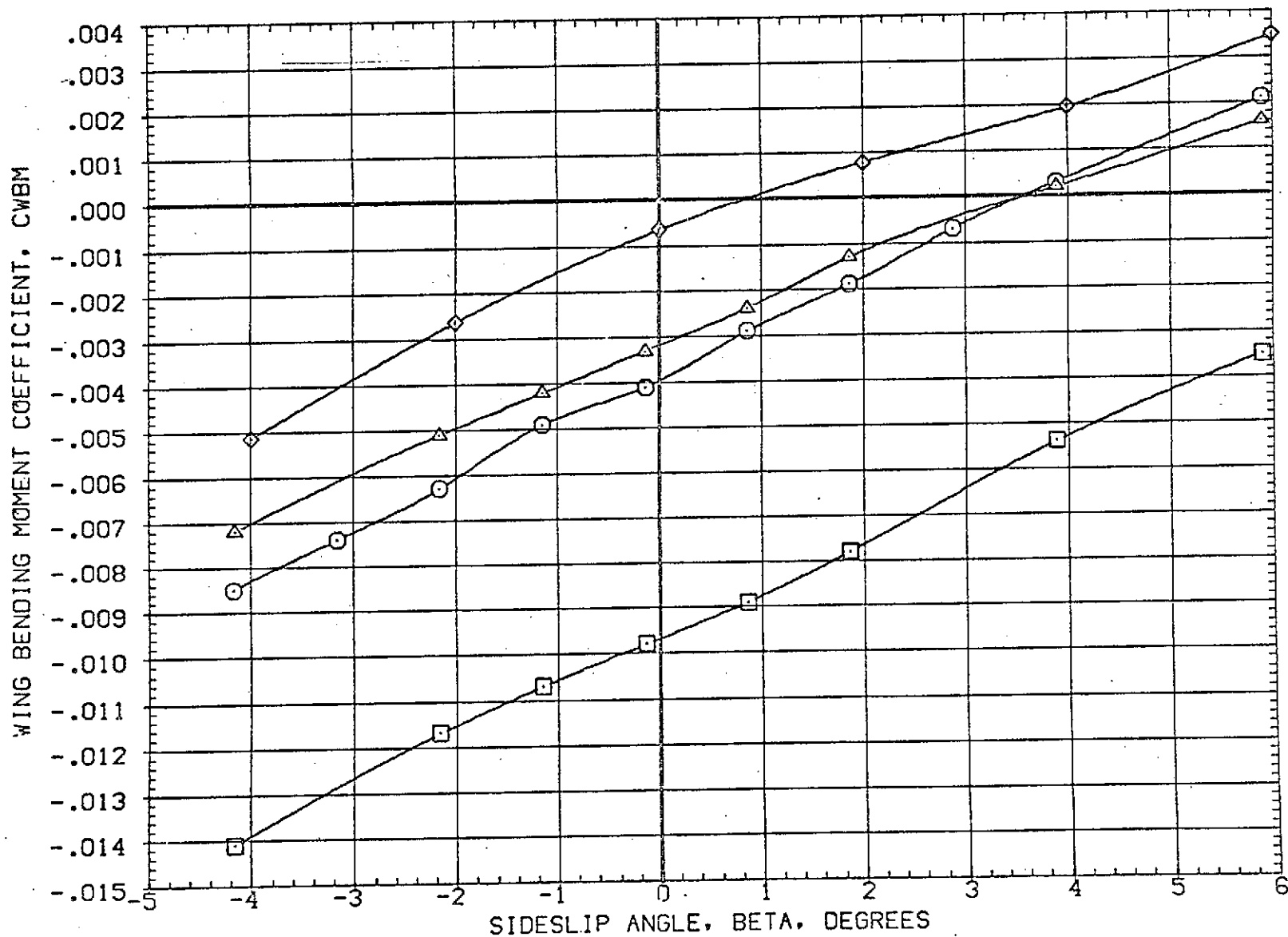

FIG 20 EFFECT OF PLUMES ON AILERON POWER, ALPHA=0.0

(A)MACH = 1.60

DATA SET SYMBOL	CONFIGURATION DESCRIPTION	ELEVON	AILRON	RUDDER	PLUMES	REFERENCE INFORMATION
(DBJ502)	AMES 97-616 1A2 01 TO S1 NO PLUMES	.000	.000	.000	.000	SREF 3155.0000 SQ.FT.
(RBJ523)	AMES 97-616 1A2 01 TO S1 NO PLUMES	.000	10.000	.000	.000	LREF 50.8000 FT.
(HBJ002)	AMES 97-616 1A2 01 TO S1 PC/PT-NOM SRM A/A-8	.000	.000	.000	5.000	BREF 73.5000 FT.
(RBJ023)	AMES 97-616 1A2 01 TO S1 PC/PT-NOM SRM A/A-8	.000	10.000	.000	5.000	XMRP 86.4167 FT. YMRP .0000 FT. ZMRP 4.0000 FT. SCALE .0190

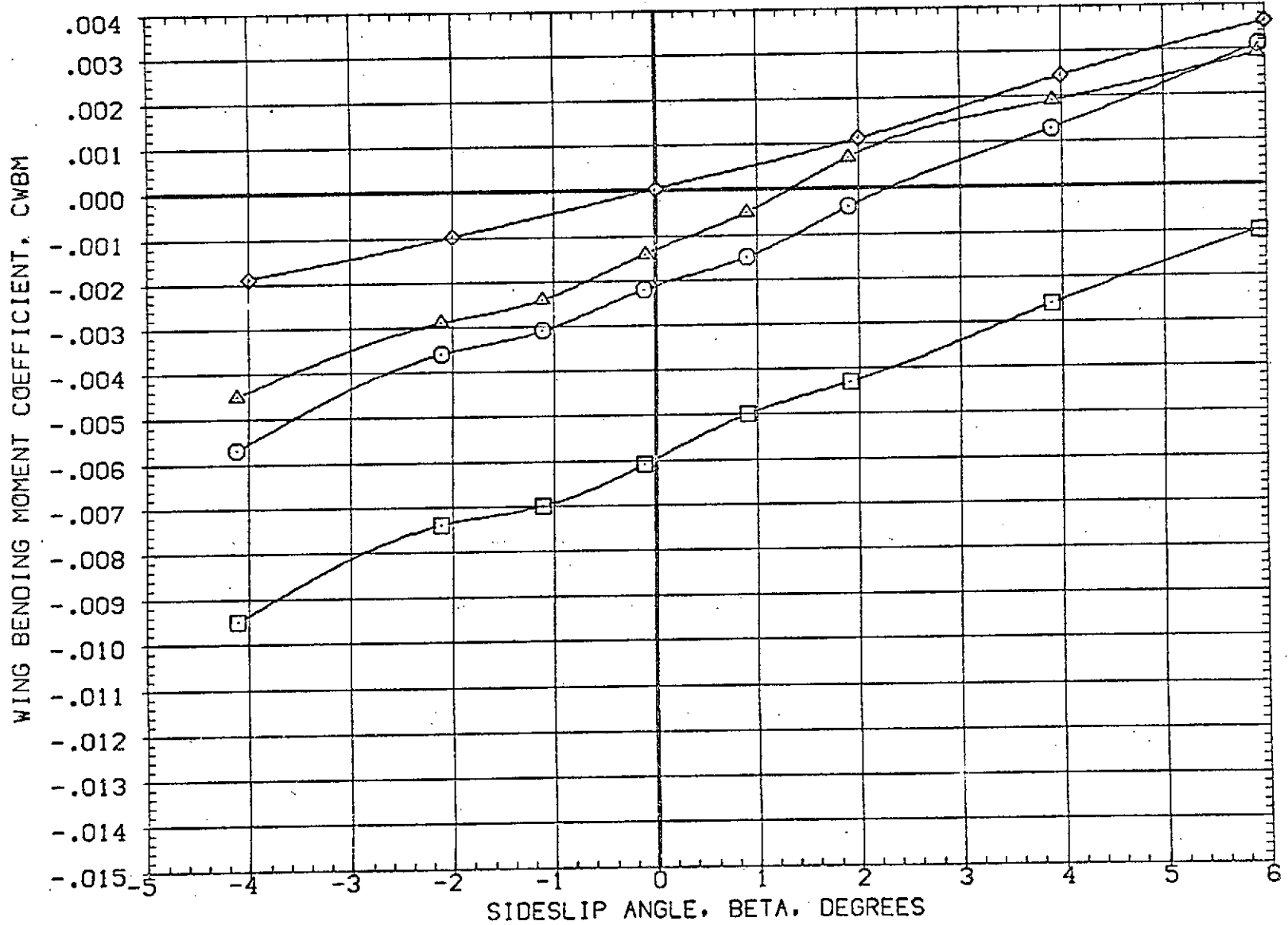

FIG 20 EFFECT OF PLUMES ON AILERON POWER, ALPHA=0.0

(RMACH = 1.98

DATA SET SYMBOL	CONFIGURATION DESCRIPTION	ELEVON	AILRON	RUDDER	PLUMES	REFERENCE INFORMATION
(DBJ001)	AMES 97-616 IA2 01 TO S1 PC/PT NOM. SRM A/A=8	.000	.000	.000	5.000	SREF 3155.0000 SQ. FT.
(DBJ011)	AMES 97-616 IA2 01 TO S1 PC/PT-NOM. SRM A/A=8	10.000	.000	10.000	5.000	LREF 50.8000 FT.
(RBJ007)	AMES 97-616 IA2 01 TO S1 SRM A/A=12. ORB NOM	.000	.000	.000	5.000	BREF 73.5000 FT.
(RBJ017)	AMES 97-616 IA2 01 TO S1 SRM A/A=12. ORB NOM	10.000	.000	10.000	5.000	XMRP 86.4167 FT.
(RBJ009)	AMES 97-616 IA2 01 TO S1 PC/PT=1.3 NOMINAL	.000	.000	.000	5.000	YMRP .0000 FT.
(RBJ019)	AMES 97-616 IA2 01 TO S1 PC/PT=1.3 NOMINAL	10.000	.000	10.000	5.000	ZMRP 4.0000 FT. SCALE .0190

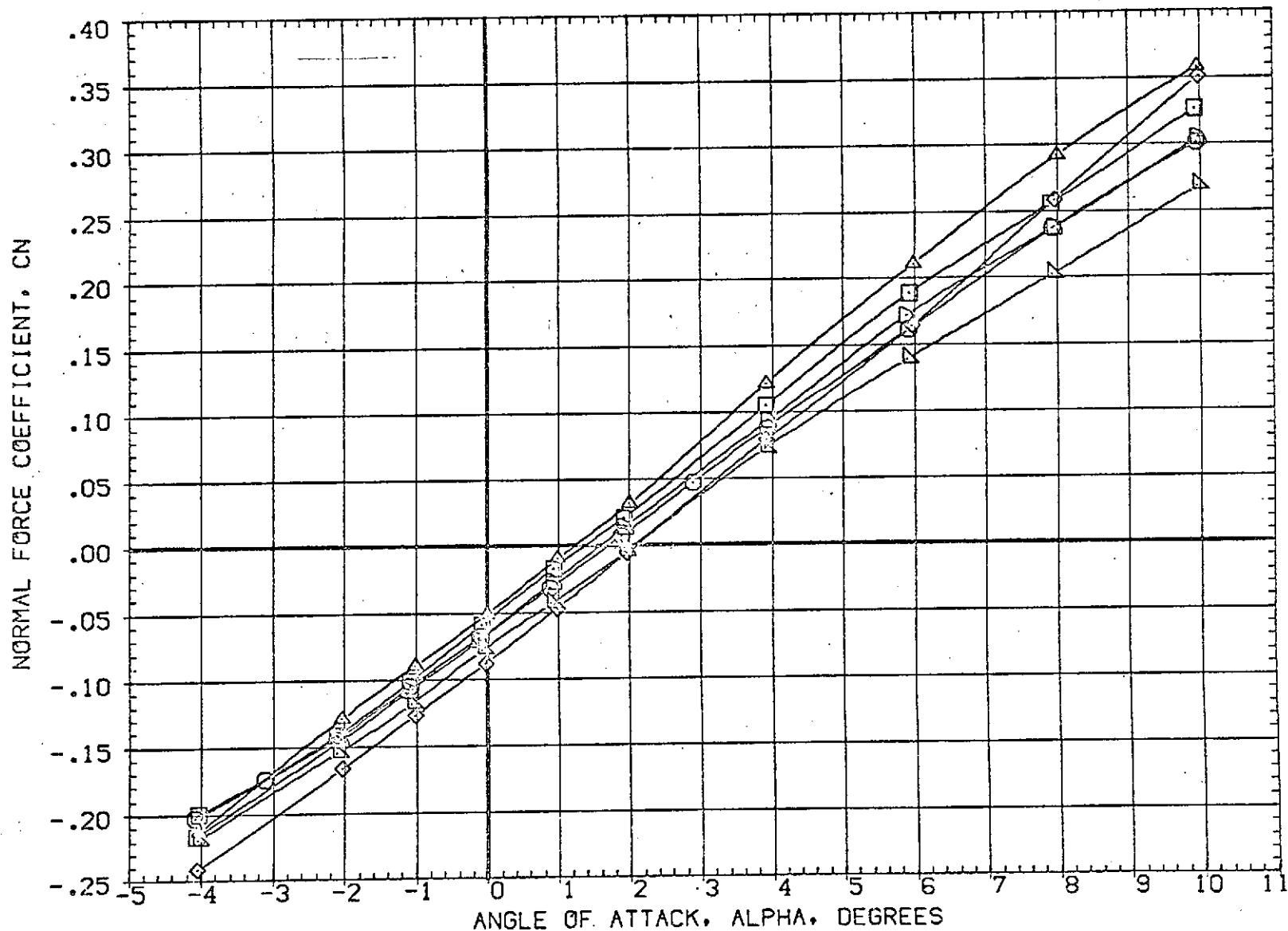

FIG 21. EFFECT OF PLUME SIZE ON ELEVON AND RUDDER POWER, BETA=0.0

(A)MACH = 1.60

DATA SET SYMBOL	CONFIGURATION DESCRIPTION	ELEVON	AILRON	RUDDER	PLUMES	REFERENCE INFORMATION	
(RBJ001)	AMES 97-616 1A2 01 TO S1 PC/PT NOM. SRM A/A=8	.000	.000	.000	5.000	SREF	3155.0000 SQ.FT.
(RBJ011)	AMES 97-616 1A2 01 TO S1 PC/PT=NOM. SRM A/A=8	10.000	.000	10.000	5.000	LREF	50.8000 FT.
(RBJ007)	AMES 97-616 1A2 01 TO S1 SRM A/A=12. ORB NOM	.000	.000	.000	5.000	BREF	73.5000 FT.
(RBJ017)	AMES 97-616 1A2 01 TO S1 SRM A/A=12. ORB NOM	10.000	.000	10.000	5.000	XMRP	86.4167 FT.
(RBJ009)	AMES 97-616 1A2 01 TO S1 PC/PT=1.3 NOMINAL	.000	.000	.000	5.000	YMRP	.0000 FT.
(RBJ019)	AMES 97-616 1A2 01 TO S1 PC/PT=1.3 NOMINAL	10.000	.000	10.000	5.000	ZMRP	4.0000 FT.
						SCALE	.0190

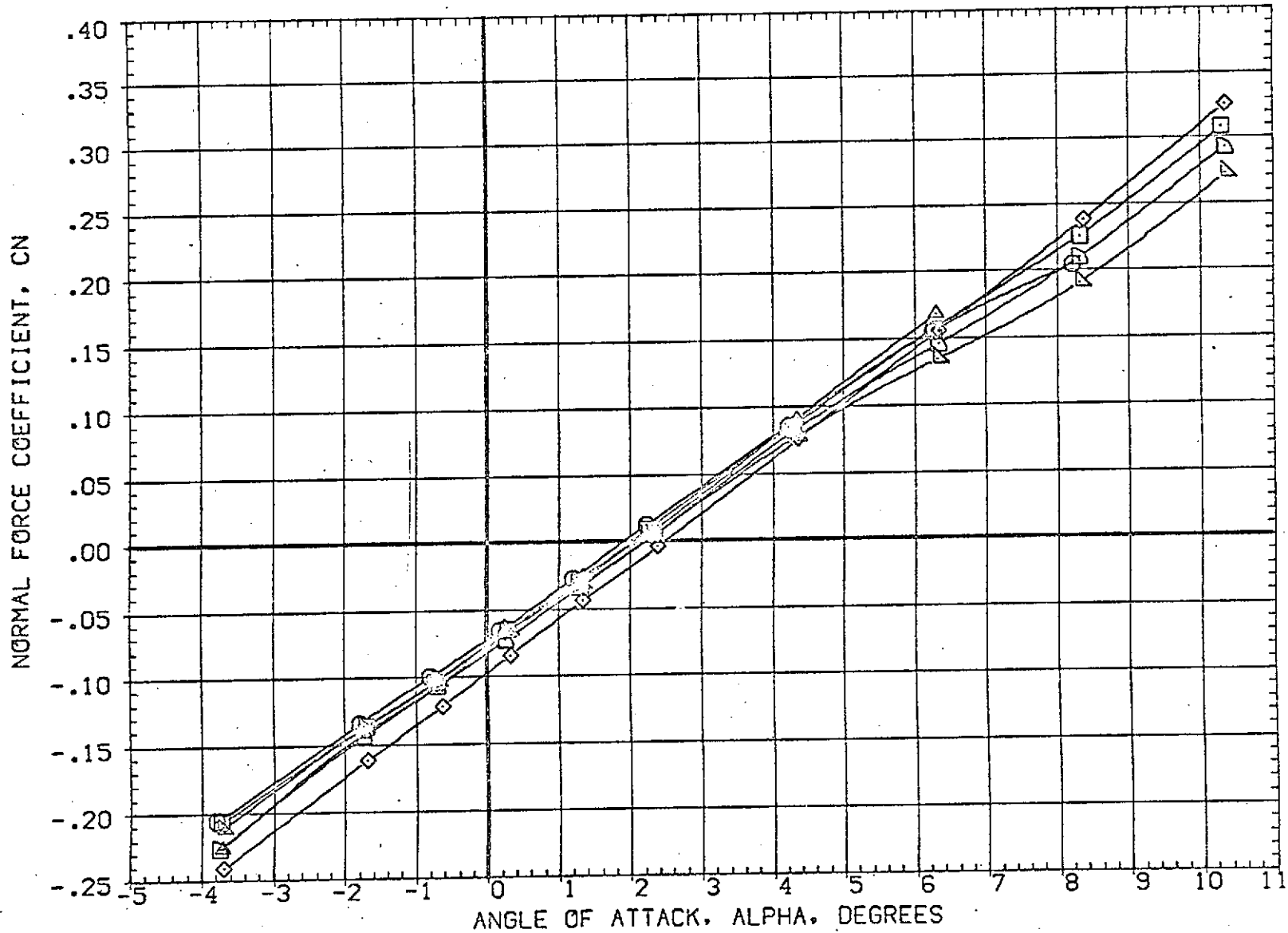

FIG 21 EFFECT OF PLUME SIZE ON ELEVON AND RUDDER POWER, BETA=0.0

(B)MACH = 1.98

DATA SET SYMBOL	CONFIGURATION DESCRIPTION	ELEVON	AILRON	RUDDER	PLUMES	REFERENCE INFORMATION
(DBJ001)	AMES 97-616 1A2 01 TO S1 PC/PT NOM. SRM A/A=8	.000	.000	.000	5.000	SREF 3155.0000 SQ.FT.
(DBJ011)	AMES 97-616 1A2 01 TO S1 PC/PT=NOM. SRM A/A=8	10.000	.000	10.000	5.000	LREF 50.8000 FT.
(RBJ007)	AMES 97-616 1A2 01 TO S1 SRM A/A=12. ORB NOM	.000	.000	.000	5.000	BREF 73.5000 FT.
(RBJ017)	AMES 97-616 1A2 01 TO S1 SRM A/A=12. ORB NOM	10.000	.000	10.000	5.000	XMRP 86.4167 FT.
(RBJ009)	AMES 97-616 1A2 01 TO S1 PC/PT=1.3 NOMINAL	.000	.000	.000	5.000	YMRP .0000 FT.
(RBJ019)	AMES 97-616 1A2 01 TO S1 PC/PT=1.3 NOMINAL	10.000	.000	10.000	5.000	ZMRP 4.0000 FT.
						SCALE .0190

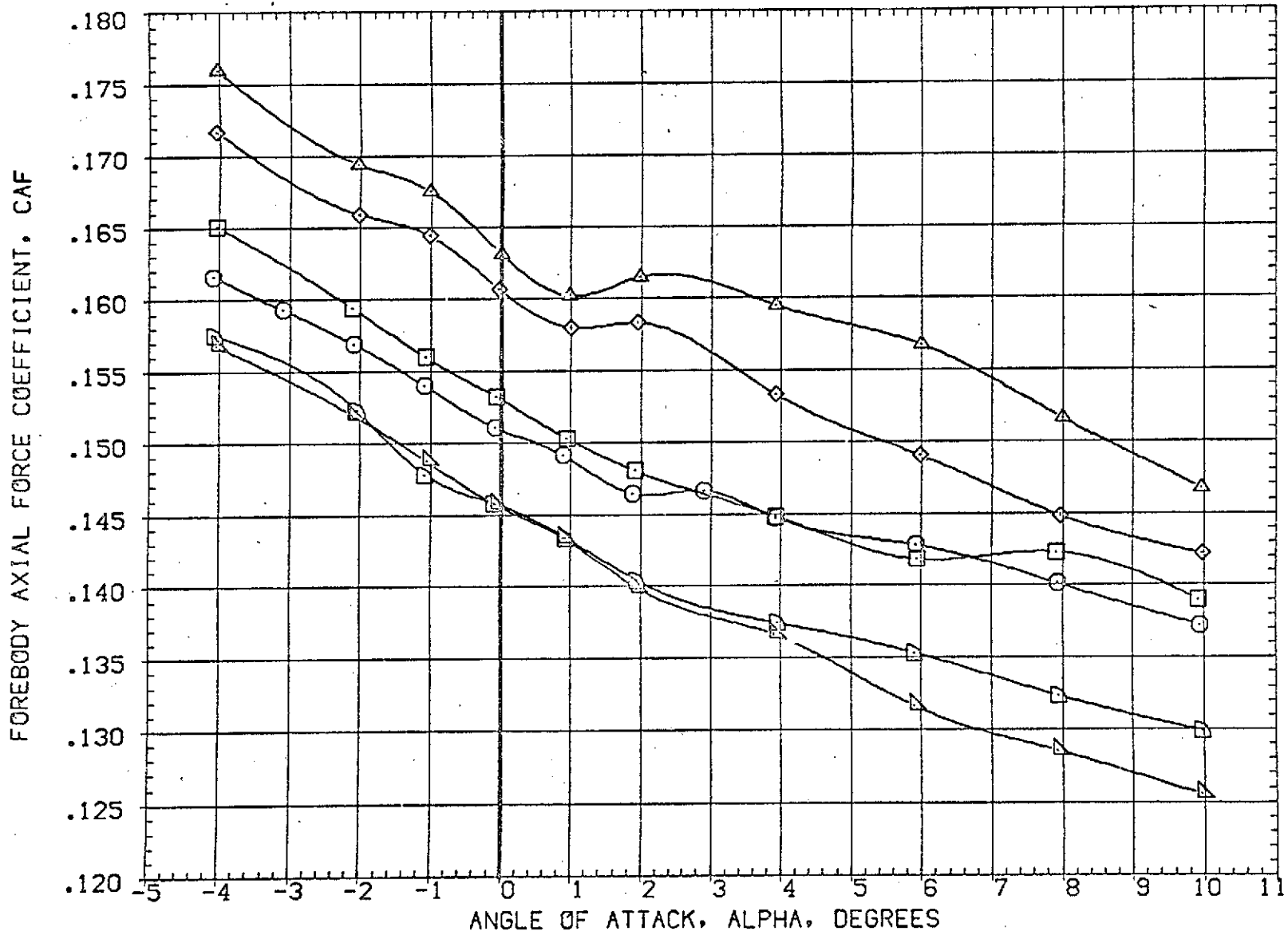

FIG 21 EFFECT OF PLUME SIZE ON ELEVON AND RUDDER POWER, BETA=0.0

(A) MACH = 1.60

DATA SET SYMBOL	CONFIGURATION DESCRIPTION	ELEVON	AILRON	RUDDER	PLUMES	REFERENCE INFORMATION
(DBJ001)	AMES 97-616 1A2 01 T0 S1 PC/PT NOM, SRM A/A=8	.000	.000	.000	5.000	SREF 3155.0000 SQ.FT.
(DBJ011)	AMES 97-616 1A2 01 T0 S1 PC/PT=NOM, SRM A/A=8	10.000	.000	10.000	5.000	LREF 50.9000 FT.
(RBJ007)	AMES 97-616 1A2 01 T0 S1 SRM A/A=12, CRB NOM	.000	.000	.000	5.000	BREF 73.5000 FT.
(RBJ017)	AMES 97-616 1A2 01 T0 S1 SRM A/A=12, CRB NOM	10.000	.000	10.000	5.000	XMRP 86.4167 FT.
(RBJ009)	AMES 97-616 1A2 01 T0 S1 PC/PT=1.3 NOMINAL	.000	.000	.000	5.000	YMRP .0000 FT.
(RBJ019)	AMES 97-616 1A2 01 T0 S1 PC/PT=1.3 NOMINAL	10.000	.000	10.000	5.000	ZMRP 4.0000 FT.
						SCALE .0190

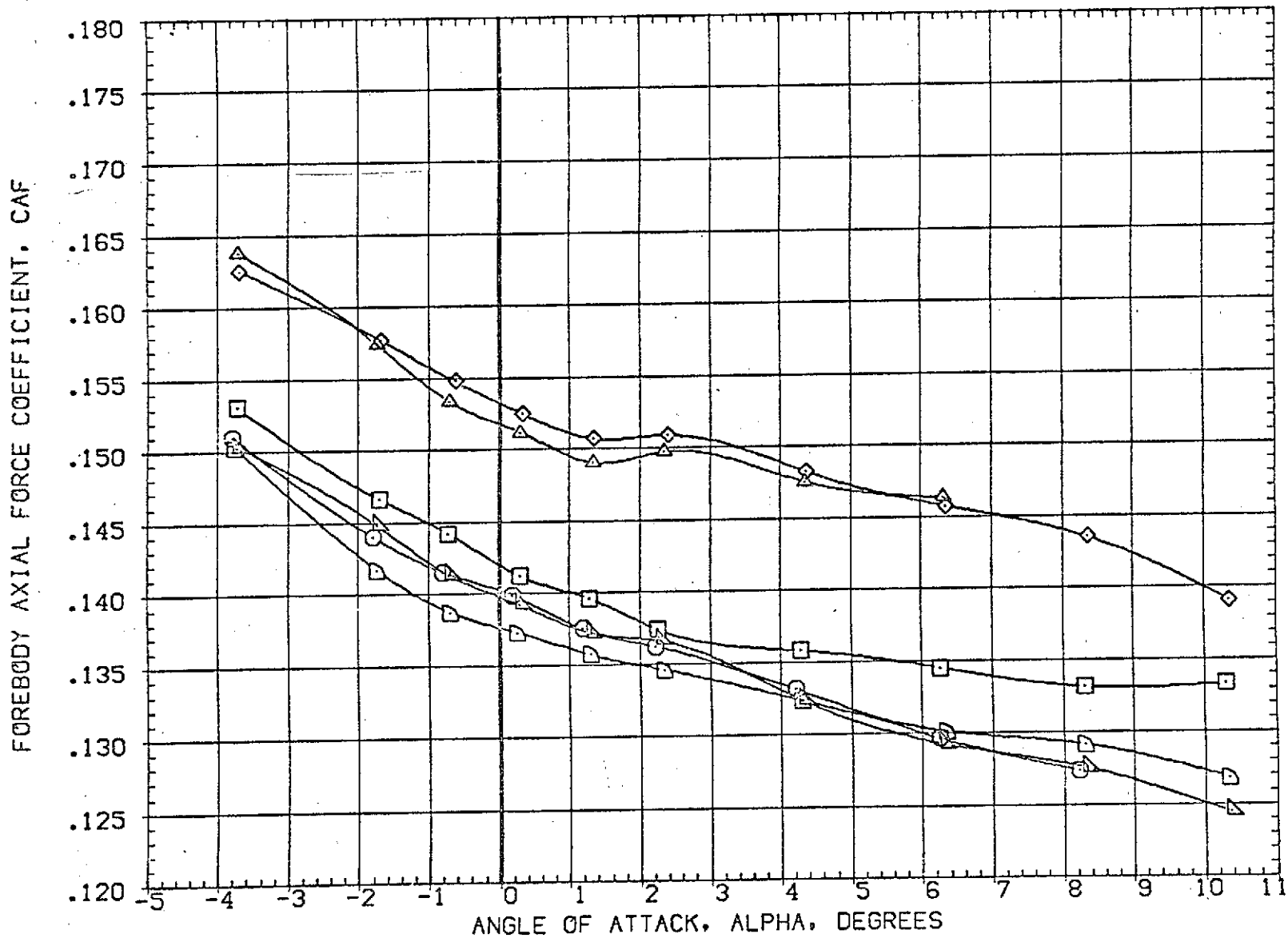

FIG 21 EFFECT OF PLUME SIZE ON ELEVON AND RUDDER POWER, BETA=0.0

(B)MACH = 1.98

DATA SET SYMBOL	CONFIGURATION DESCRIPTION	ELEVON	AILRON	RUDDER	PLUMES	REFERENCE INFORMATION
(09J001)	AMES 97-616 1A2 01 TO S1 PC/PT NOM. SRM A/A=8	.000	.000	.000	5.000	SREF 3155.0000 SQ.FT.
(09J011)	AMES 97-616 1A2 01 TO S1 PC/PT=NOM. SRM A/A=8	10.000	.000	10.000	5.000	LREF 50.8000 FT.
(R3J007)	AMES 97-616 1A2 01 TO S1 SRM A/A=12.0R8 NOM	.000	.000	.000	5.000	BREF 73.5000 FT.
(R3J017)	AMES 97-616 1A2 01 TO S1 SRM A/A=12.0R8 NOM	10.000	.000	10.000	5.000	XMRP 86.4167 FT.
(R3J009)	AMES 97-616 1A2 01 TO S1 PC/PT=1.3 NOMINAL	.000	.000	.000	5.000	YMRP .0000 FT.
(R3J019)	AMES 97-616 1A2 01 TO S1 PC/PT=1.3 NOMINAL	10.000	.000	10.000	5.000	ZMRP 4.0000 FT. SCALE .0190

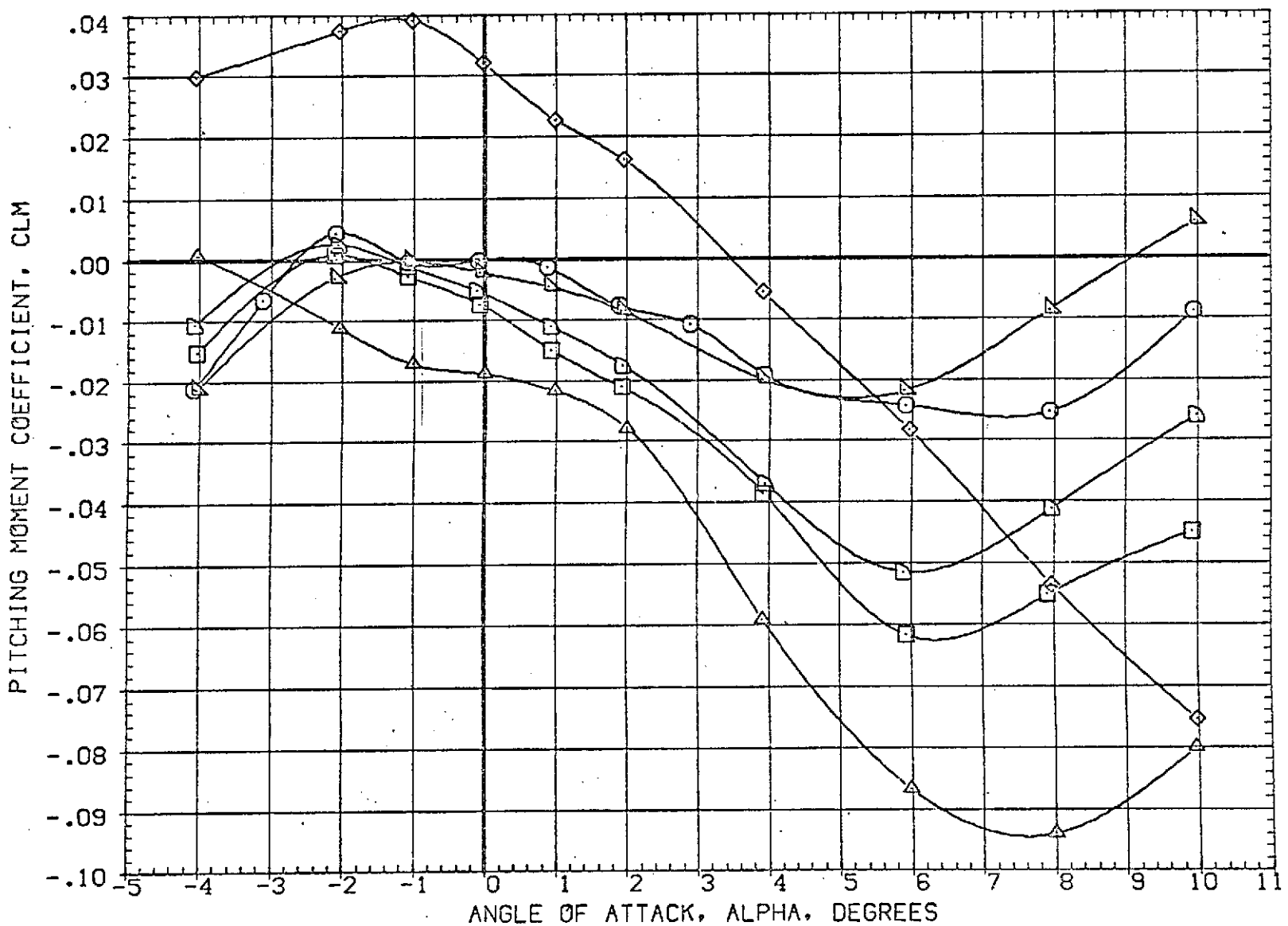

FIG 21 EFFECT OF PLUME SIZE ON ELEVON AND RUDDER POWER, BETA=0.0

(A)MACH = 1.60

DATA SET SYMBOL	CONFIGURATION DESCRIPTION	ELEVON	AILRON	RUDDER	PLUMES	REFERENCE INFORMATION
(DBJ001)	AMES 97-616 IA2 01 TO S1 PC/PT-NOM,SRM A/A=8	10.000	.000	.000	5.000	SREF 3155.0000 SQ.FT.
(DBJ011)	AMES 97-616 IA2 01 TO S1 PC/PT-NOM,SRM A/A=8	10.000	.000	10.000	5.000	LREF 50.8000 FT.
(RBJ007)	AMES 97-616 IA2 01 TO S1 SRM A/A=12.0RB NOM	.000	.000	.000	5.000	BREF 73.5000 FT.
(RBJ017)	AMES 97-616 IA2 01 TO S1 SRM A/A=12.0RB NOM	10.000	.000	10.000	5.000	XMRP 85.4167 FT.
(RBJ009)	AMES 97-616 IA2 01 TO S1 PC/PT=1.3 NOMINAL	.000	.000	.000	5.000	YMRP .0000 FT.
(RBJ019)	AMES 97-616 IA2 01 TO S1 PC/PT=1.3 NOMINAL	10.000	.000	10.000	5.000	ZMRP 4.0000 FT.
						SCALE .0190

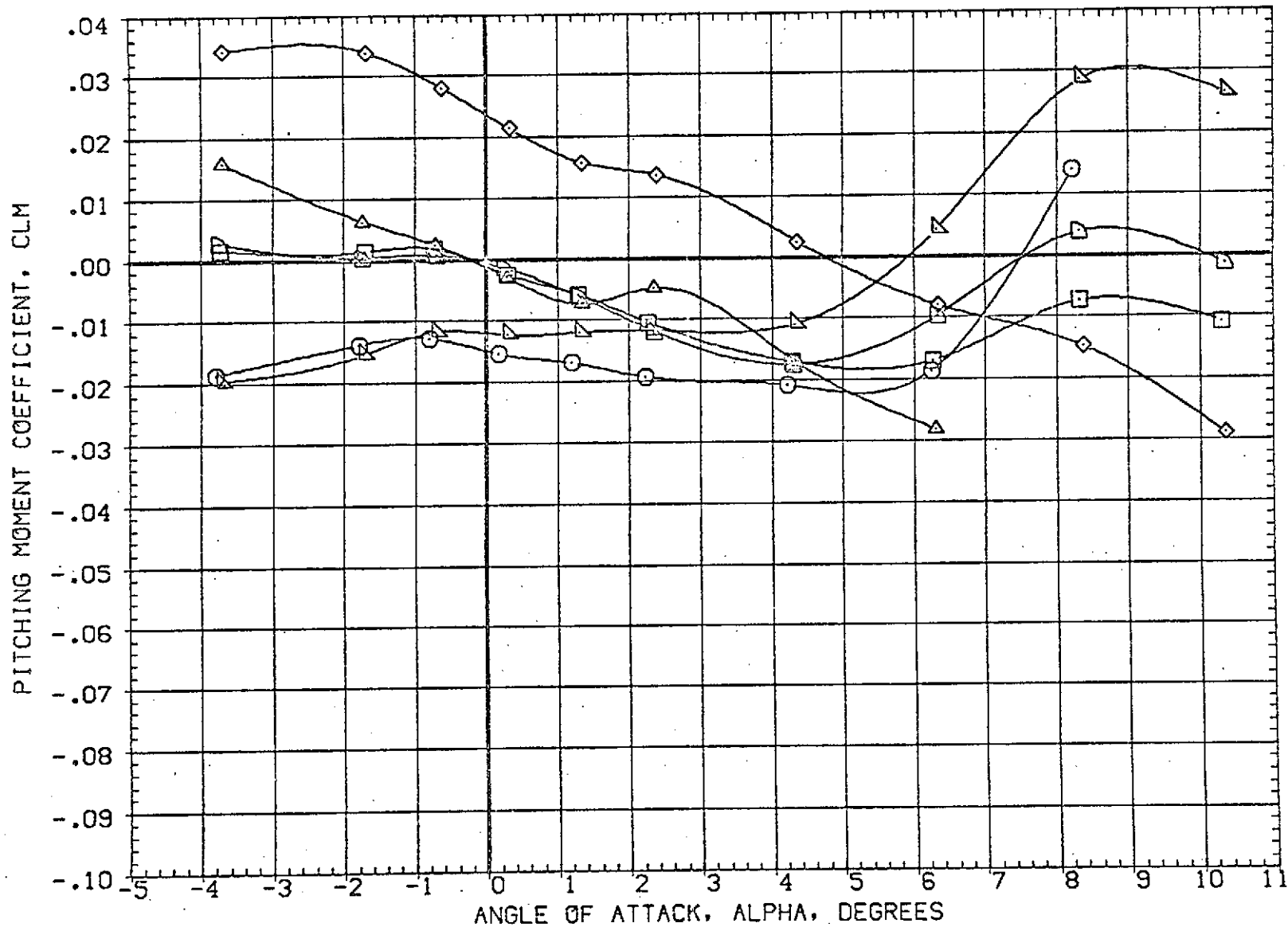

FIG 21 EFFECT OF PLUME SIZE ON ELEVON AND RUDDER POWER, BETA=0.0

(B)MACH = 1.98

DATA SET SYMBOL	CONFIGURATION DESCRIPTION	ELEVON	AILRON	RUDDER	PLUMES	REFERENCE INFORMATION
(OBJ001)	AMES 97-616 1A2 01 TO S1 PC/PT NOM. SRM A/A=8	.000	.000	.000	5.000	SREF 3155.0000 SQ.FT.
(OBJ011)	AMES 97-616 1A2 01 TO S1 PC/PT=NOM. SRM A/A=8	10.000	.000	10.000	5.000	LREF 50.8000 FT.
(RBJ007)	AMES 97-616 1A2 01 TO S1 SRM A/A=12. ORB NOM	.000	.000	.000	5.000	BREF 73.5000 FT.
(RBJ017)	AMES 97-616 1A2 01 TO S1 SRM A/A=12. ORB NOM	10.000	.000	10.000	5.000	XMRP 85.4167 FT.
(RBJ009)	AMES 97-616 1A2 01 TO S1 PC/PT=1.3 NOMINAL	.000	.000	.000	5.000	YMRP .0000 FT.
(RBJ019)	AMES 97-616 1A2 01 TO S1 PC/PT=1.3 NOMINAL	10.000	.000	10.000	5.000	ZMRP 4.0000 FT.
						SCALE .0190

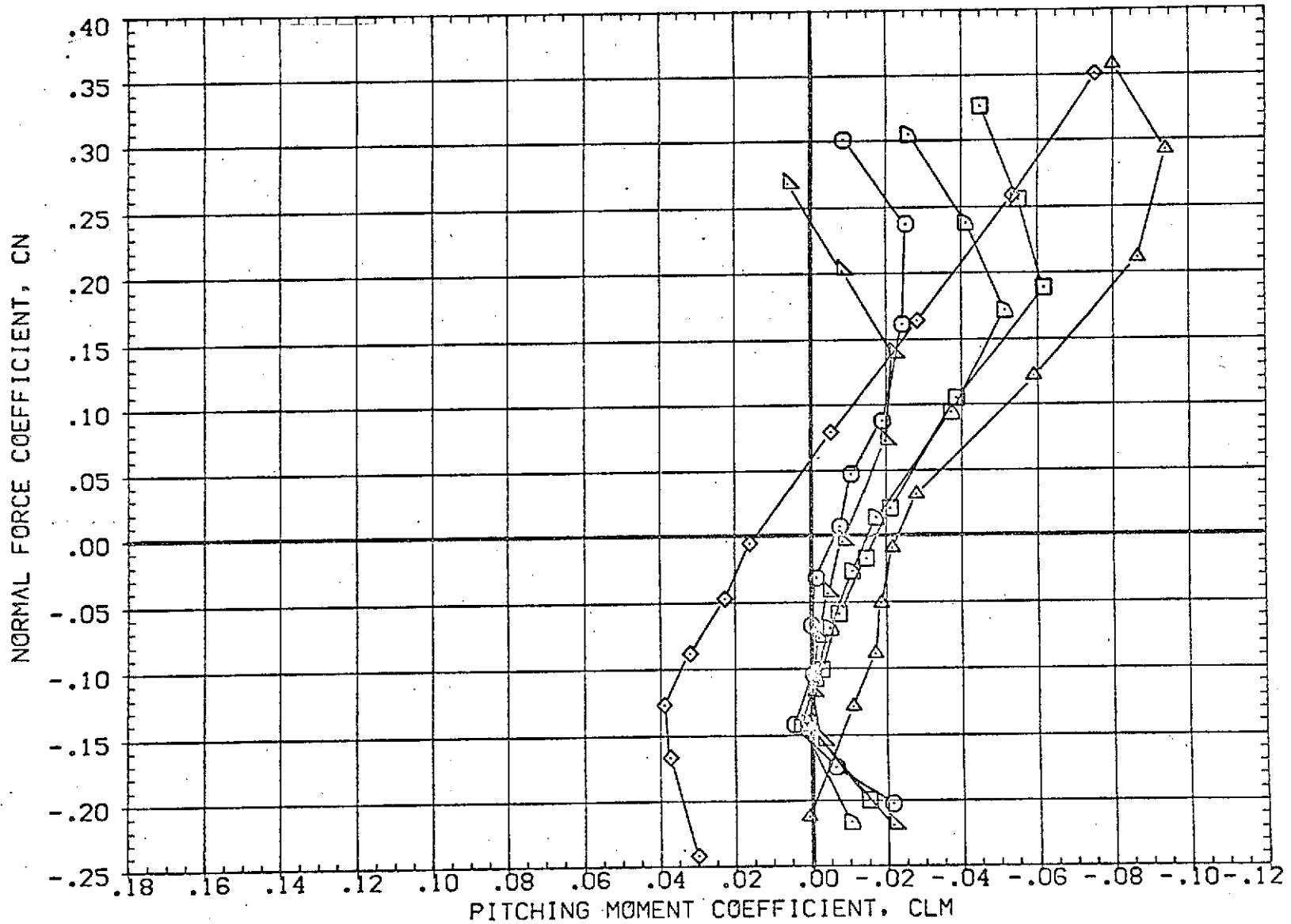

FIG 21 EFFECT OF PLUME SIZE ON ELEVON AND RUDDER POWER, BETA=0.0

DATA SET SYMBOL	CONFIGURATION DESCRIPTION	ELEVON	AILERON	RUDDER	PLUMES	REFERENCE INFORMATION
(DBJ001)	AMES 97-616 1A2 01 TO S1 PC/PT NOM. SRM A/A=8	.000	.000	.000	5.000	SREF 3155.0000 SQ. FT.
(DBJ011)	AMES 97-616 1A2 01 TO S1 PC/PT=NOM. SRM A/A=8	10.000	.000	10.000	5.000	LREF 50.8000 FT.
(RBJ007)	AMES 97-616 1A2 01 TO S1 SRM A/A=12.0RB NOM	.000	.000	.000	5.000	BREF 73.5000 FT.
(RBJ017)	AMES 97-616 1A2 01 TO S1 SRM A/A=12.0RB NOM	10.000	.000	10.000	5.000	XMRP 86.4167 FT.
(RBJ009)	AMES 97-616 1A2 01 TO S1 PC/PT=1.3 NOMINAL	.000	.000	.000	5.000	YMRP .0000 FT.
(RBJ019)	AMES 97-616 1A2 01 TO S1 PC/PT=1.3 NOMINAL	10.000	.000	10.000	5.000	ZMRP 4.0000 FT. SCALE .0190

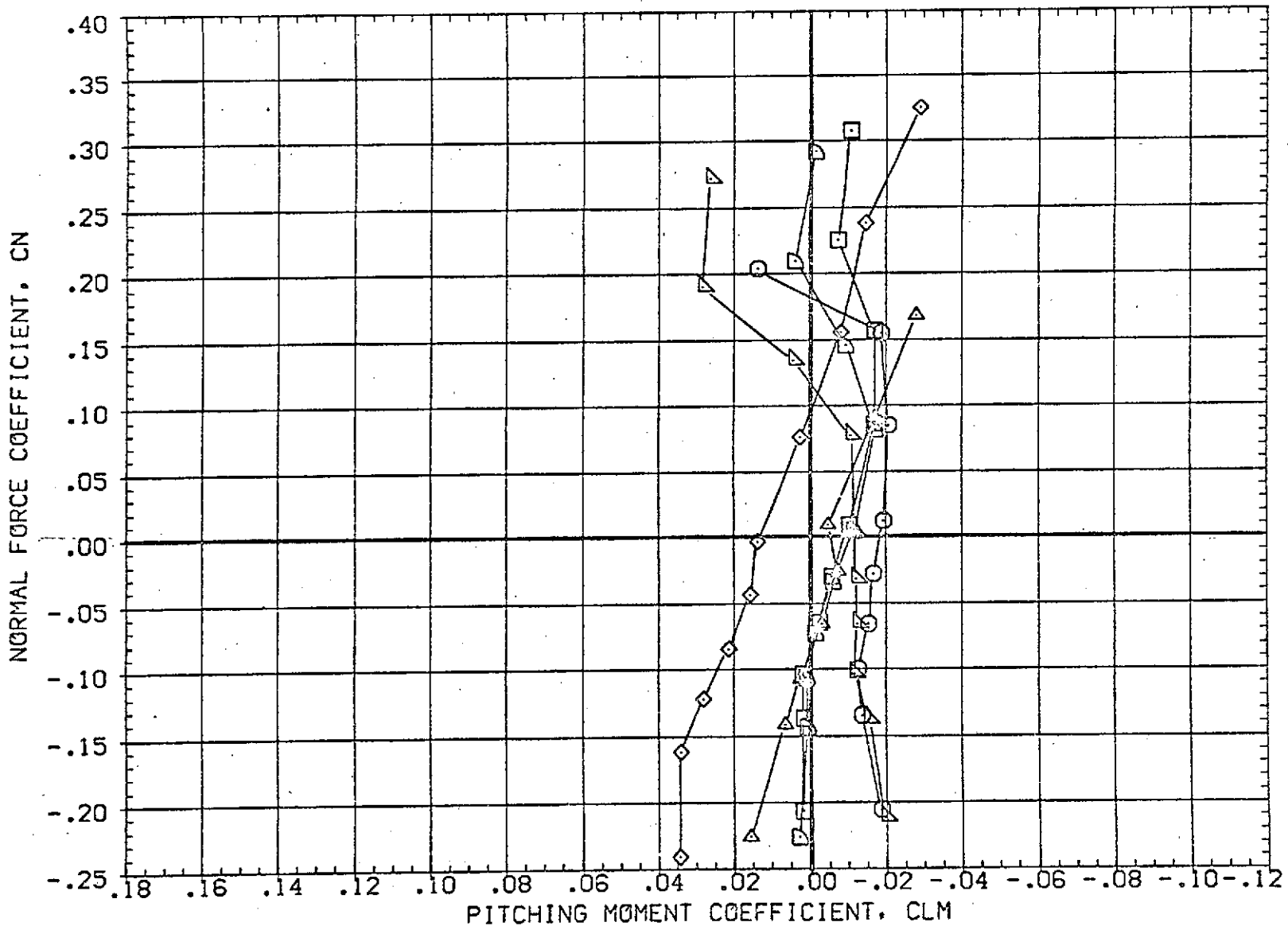

FIG 21 EFFECT OF PLUME SIZE ON ELEVON AND RUDDER POWER, BETA=0.40

(B)MACH = 1.98

DATA SET SYMBOL	CONFIGURATION DESCRIPTION	ELEVON	AILRON	RUDDER	PLUMES	REFERENCE INFORMATION
(DBJ001)	AMES 97-616 IA2 01 TO S1 PC/PT NOM. SRM A/A=8	.000	.000	.000	5.000	SREF 3155.0000 SQ.FT.
(DBJ011)	AMES 97-616 IA2 01 TO S1 PC/PT=NOM. SRM A/A=8	10.000	.000	10.000	5.000	LREF 50.8000 FT.
(RBJ007)	AMES 97-616 IA2 01 TO S1 SRM A/A=12.0RB NOM	.000	.000	.000	5.000	BREF 73.5000 FT.
(RBJ017)	AMES 97-616 IA2 01 TO S1 SRM A/A=12.0RB NOM	10.000	.000	10.000	5.000	XMRP 86.4167 FT.
(RBJ009)	AMES 97-616 IA2 01 TO S1 PC/PT=1.3 NOMINAL	.000	.000	.000	5.000	YMRP .0000 FT.
(RBJ019)	AMES 97-616 IA2 01 TO S1 PC/PT=1.3 NOMINAL	10.000	.000	10.000	5.000	ZMRP 4.0000 FT. SCALE .0190

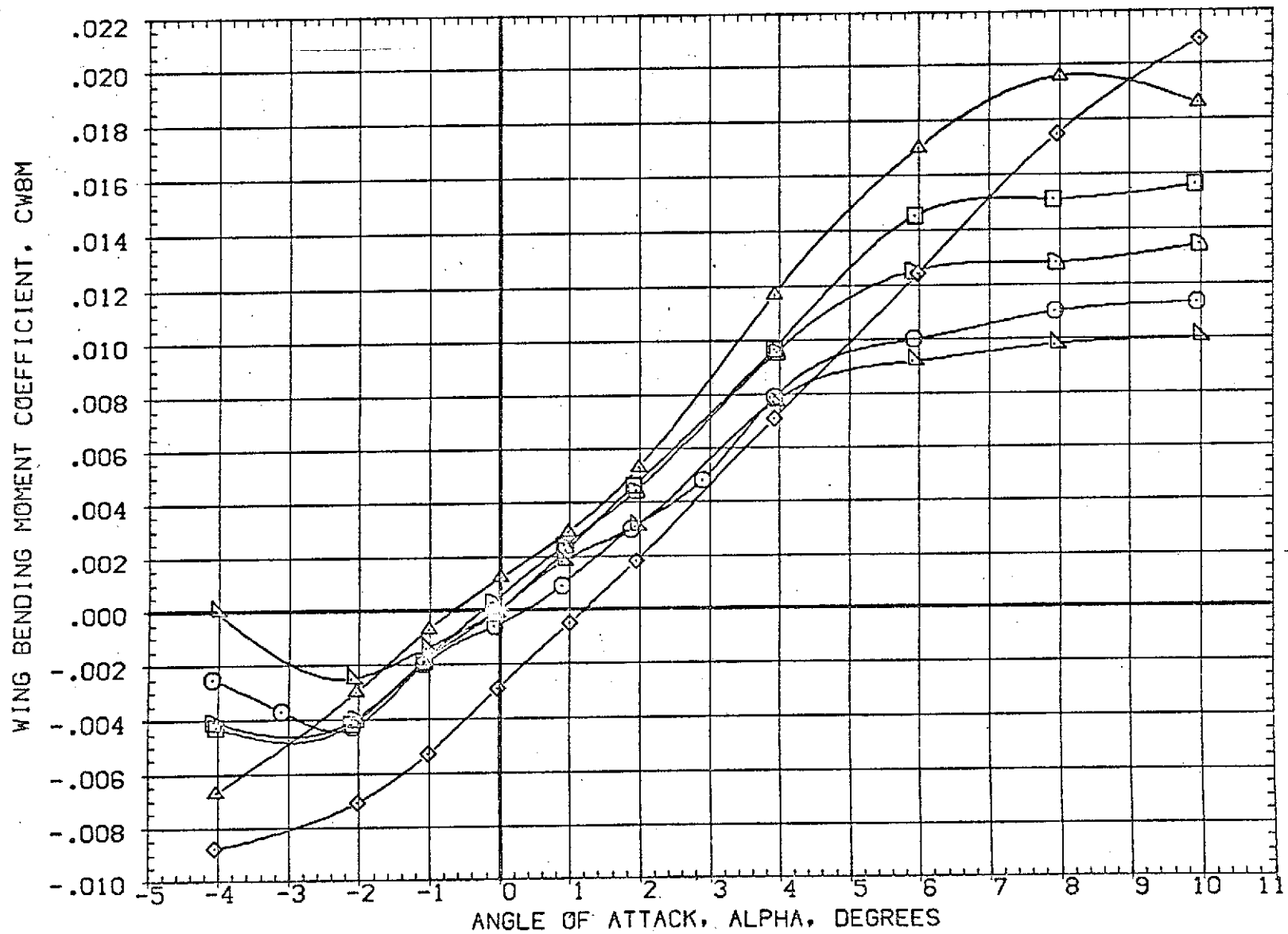

FIG 21 EFFECT OF PLUME SIZE ON ELEVON AND RUDDER POWER, BETA=0.0

(A)MACH = 1.60

DATA SET SYMBOL	CONFIGURATION DESCRIPTION	ELEVON	AILERON	RUDDER	PLUMES	REFERENCE INFORMATION
(DBJ001)	AMES 97-616 1A2 01 TO S1 PC/PT NOM, SRM A/A=8	.000	.000	.000	5.000	SREF 3155.0000 SQ.FT
(DBJ011)	AMES 97-616 1A2 01 TO S1 PC/PT=NOM, SRM A/A=8	10.000	.000	10.000	5.000	LREF 50.8000 FT.
(RBJ007)	AMES 97-616 1A2 01 TO S1 SRM A/A=12, ORB NOM	.000	.000	.000	5.000	BREF 73.5000 FT.
(RBJ017)	AMES 97-616 1A2 01 TO S1 SRM A/A=12, ORB NOM	10.000	.000	10.000	5.000	XMRP 86.4167 FT.
(RBJ009)	AMES 97-616 1A2 01 TO S1 PC/PT=1.3 NOMINAL	.000	.000	.000	5.000	YMRP .0000 FT.
(RBJ019)	AMES 97-616 1A2 01 TO S1 PC/PT=1.3 NOMINAL	10.000	.000	10.000	5.000	ZMRP 4.0000 FT.
						SCALE .0190

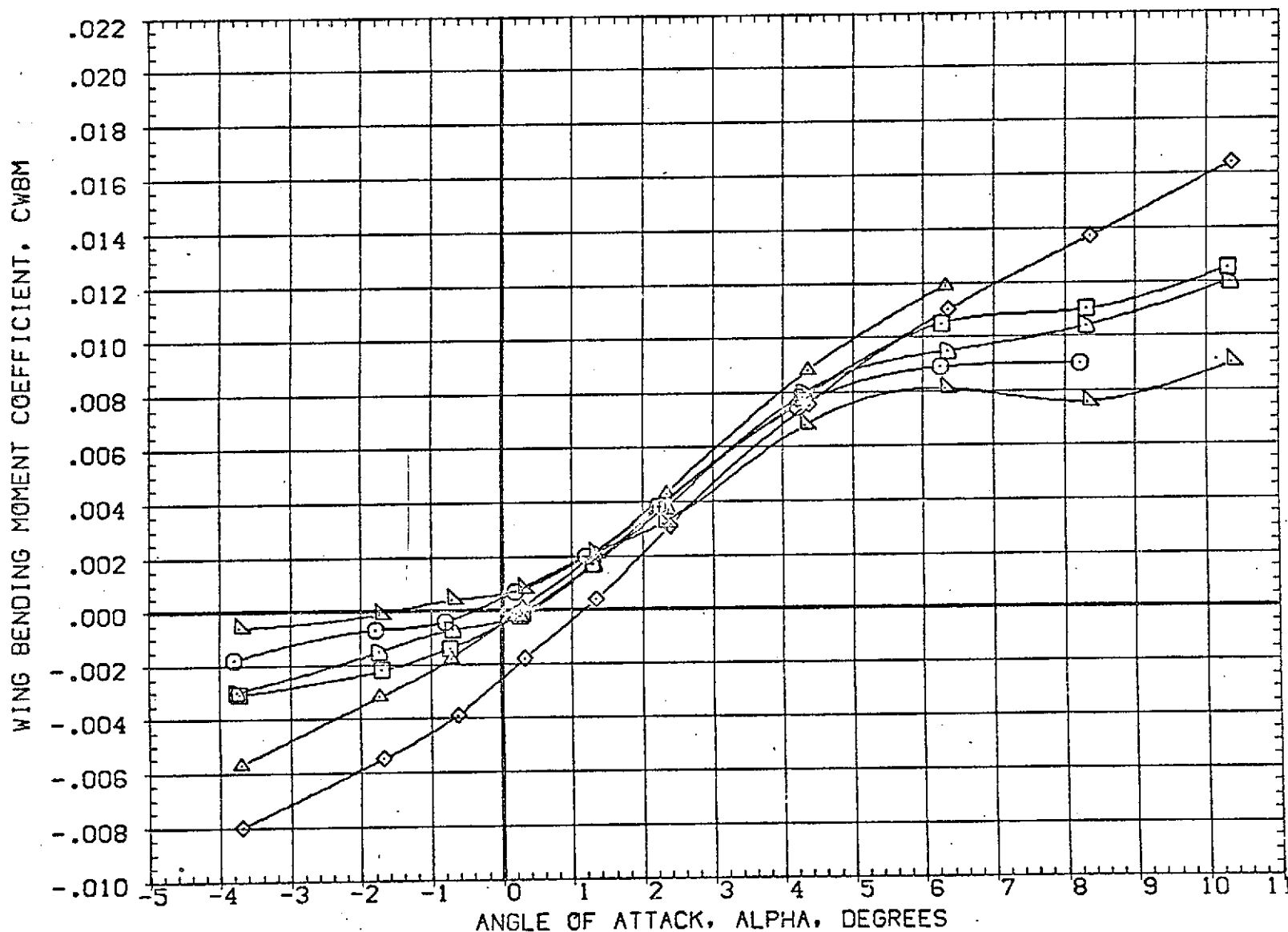

FIG 21 EFFECT OF PLUME SIZE ON ELEVON AND RUDDER POWER, BETA=0.0

(B)MACH = 1.98

DATA SET SYMBOL	CONFIGURATION DESCRIPTION	ELEVON	AILERON	RUDDER	PLUMES	REFERENCE INFORMATION
(RBJ001)	AMES 97-616 IA2 01 TO S1 PC/PT NOM, SRM A/A=8	.000	.000	.000	5.000	SREF 3155.0000 SQ.FT.
(RBJ011)	AMES 97-616 IA2 01 TO S1 PC/PT=NOM, SRM A/A=8	10.000	.000	10.000	5.000	LREF 50.8000 FT.
(RBJ007)	AMES 97-616 IA2 01 TO S1 SRM A/A=12, CRB NOM	.000	.000	.000	5.000	BREF 73.5000 FT.
(RBJ017)	AMES 97-616 IA2 01 TO S1 SRM A/A=12, CRB NOM	10.000	.000	10.000	5.000	XMRP 86.4167 FT.
(RBJ009)	AMES 97-616 IA2 01 TO S1 PC/PT=1.3 NOMINAL	.000	.000	.000	5.000	YMRP .0000 FT.
(RBJ019)	AMES 97-616 IA2 01 TO S1 PC/PT=1.3 NOMINAL	10.000	.000	10.000	5.000	ZMRP 4.0000 FT.
						SCALE .0190

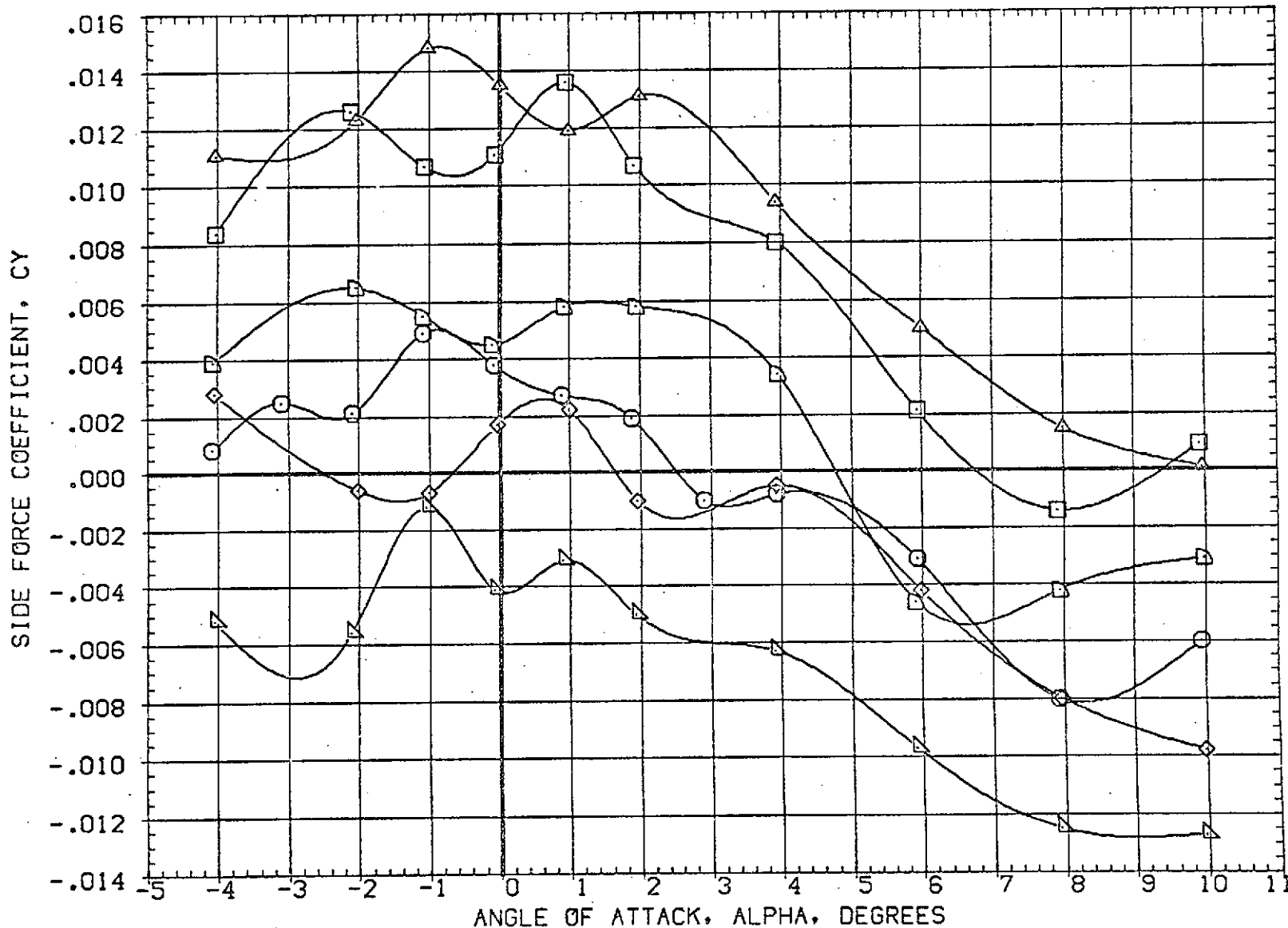

FIG 21 EFFECT OF PLUME SIZE ON ELEVON AND RUDDER POWER, BETA=0.0

(A)MACH = 1.60

DATA SET SYMBOL	CONFIGURATION DESCRIPTION	ELEVON	AILERON	RUDDER	PLUMES	REFERENCE INCH	ATTACH
(DBJ001)	AMES 97-616 1A2 01 TO S1 PC/PT NOM SRM A/A=8	.000	.000	.000	\$5.000	SREF	3155.0000 SQ.FT.
(DBJ011)	AMES 97-616 1A2 01 TO S1 PC/PT=NOM SRM A/A=8	10.000	.000	10.000	\$5.000	LREF	50.8000 FT.
(RBJ007)	AMES 97-616 1A2 01 TO S1 SRM A/A=12.0RB NOM	.000	.000	.000	\$5.000	BREF	73.5000 FT.
(RBJ017)	AMES 97-616 1A2 01 TO S1 SRM A/A=12.0RB NOM	10.000	.000	10.000	\$5.000	XMRP	86.4167 FT.
(RBJ009)	AMES 97-616 1A2 01 TO S1 PC/PT=1.3 NOMINAL	.000	.000	.000	\$5.000	YMRP	.0000 FT.
(RBJ019)	AMES 97-616 1A2 01 TO S1 PC/PT=1.3 NOMINAL	10.000	.000	10.000	\$5.000	ZMRP	4.0000 FT.
						SCALE	.0190

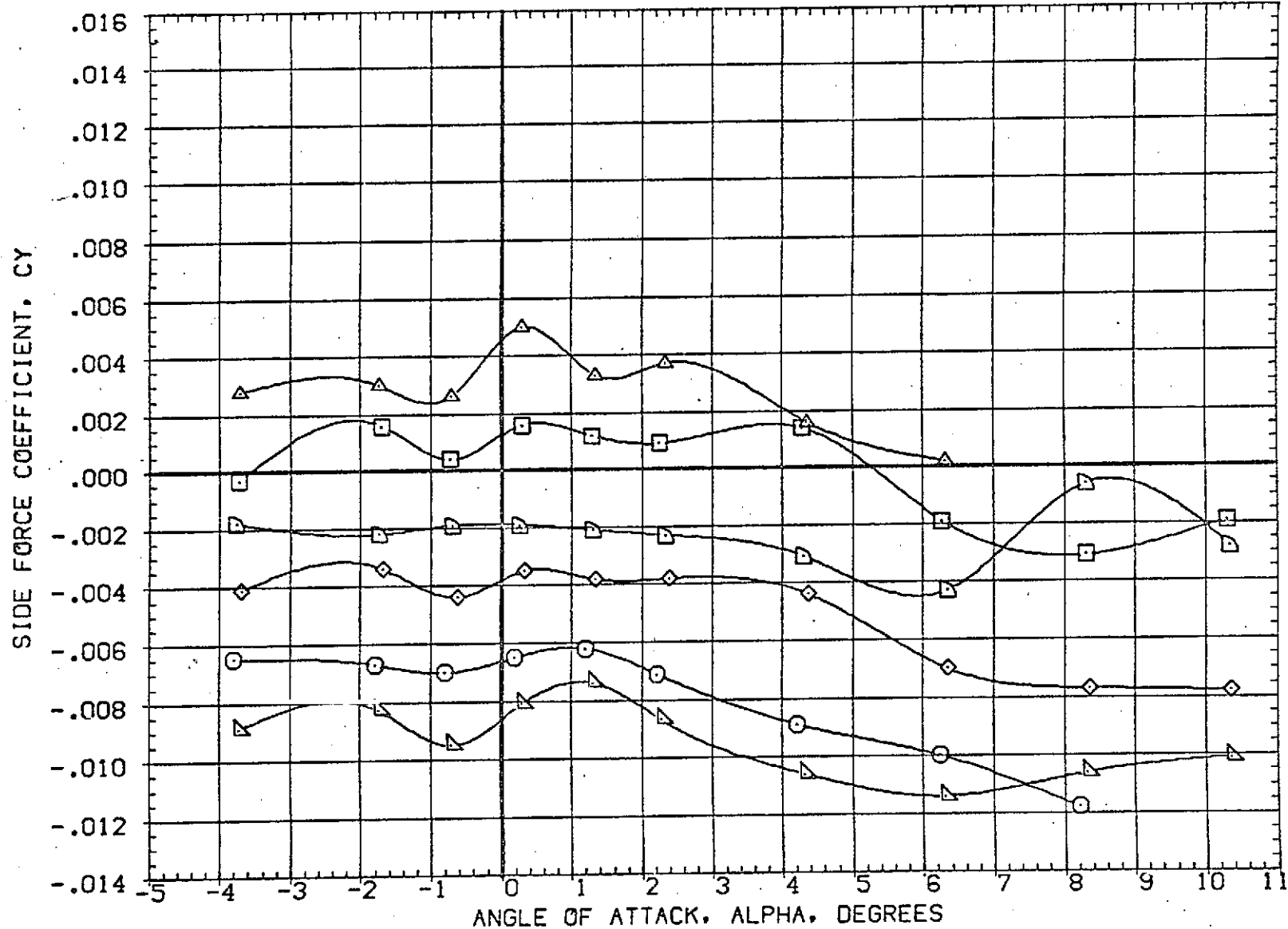

FIG 21 EFFECT OF PLUME SIZE ON ELEVON AND RUDDER POWER, BETA=0.0

(B)MACH = 1.98

DATA SET SYMBOL	CONFIGURATION DESCRIPTION	ELEVON	AILRON	RUDDER	PLUMES	REFERENCE INFORMATION
(DBJ001)	AMES 97-616 1A2 01 T8 S1 PC/PT NOM. SRM A/A=8	.000	.000	.000	5.000	SREF 3155.0000 SQ.FT.
(DBJ011)	AMES 97-616 1A2 01 T8 S1 PC/PT=NOM. SRM A/A=8	10.000	.000	10.000	5.000	LREF 50.8000 FT.
(RBJ007)	AMES 97-616 1A2 01 T8 S1 SRM A/A=12.0RB NOM	.000	.000	.000	5.000	BREF 73.5000 FT.
(RBJ017)	AMES 97-616 1A2 01 T8 S1 SRM A/A=12.0RB NOM	10.000	.000	10.000	5.000	XMRP 86.4167 FT.
(RBJ009)	AMES 97-616 1A2 01 T8 S1 PC/PT=1.3 NOMINAL	.000	.000	.000	5.000	YMRP .0000 FT.
(RBJ019)	AMES 97-616 1A2 01 T8 S1 PC/PT=1.3 NOMINAL	10.000	.000	10.000	5.000	ZMRP 4.0000 FT.
						SCALE .0190

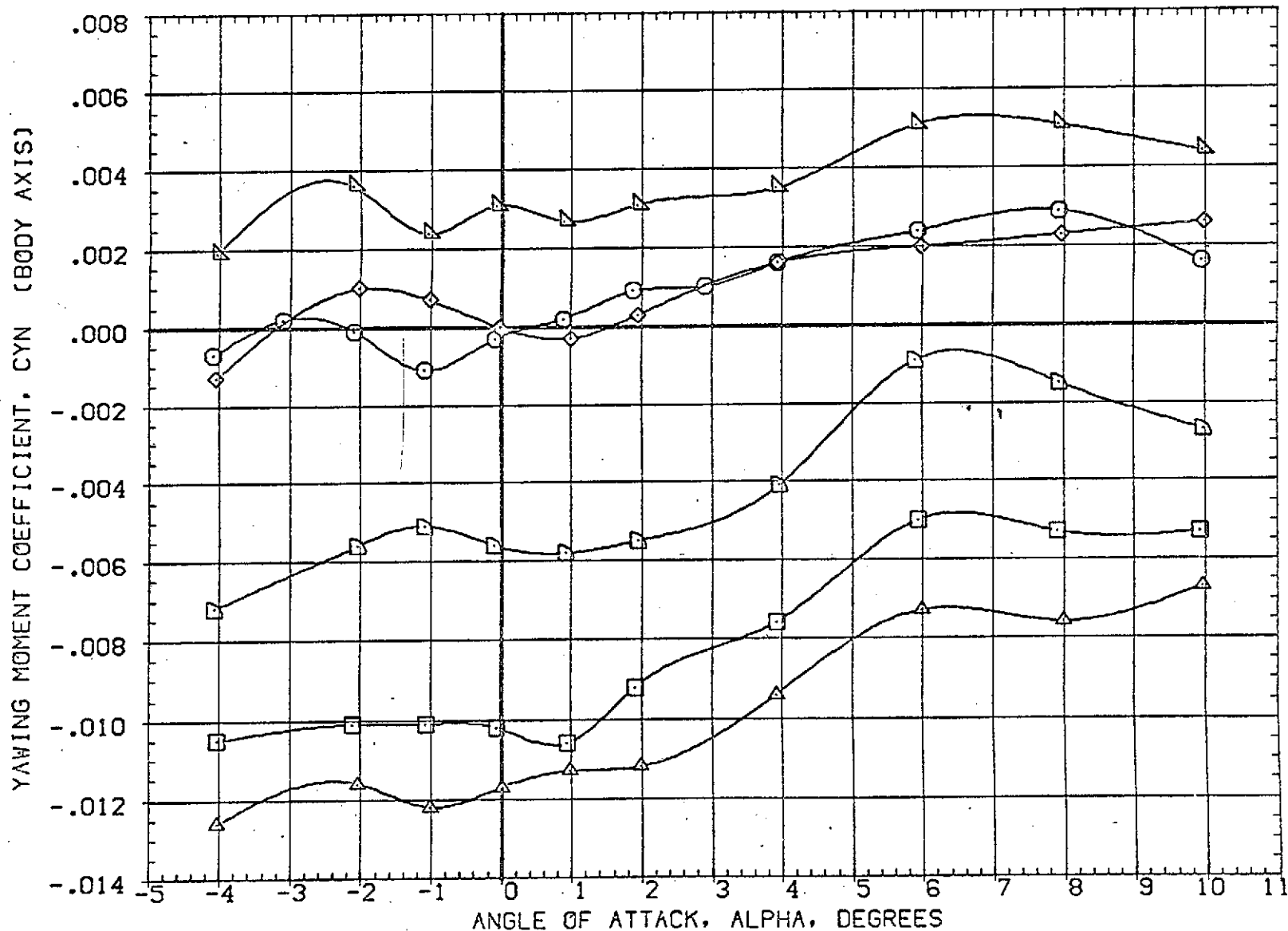

FIG 21 EFFECT OF PLUME SIZE ON ELEVON AND RUDDER POWER, BETA=0.0

(A) MACH = 1.60

DATA SET SYMBOL	CONFIGURATION DESCRIPTION	ELEVON	AILERON	RUDDER	PLUMES	REFERENCE INFORMATION
(OBJ001)	AMES 97-616 IA2 01 TO S1 PC/PT NOM, SRM A/A=8	.000	.000	.000	5.000	SREF 3155.0000 SQ.F.
(OBJ011)	AMES 97-616 IA2 01 TO S1 PC/PT=NOM, SRM A/A=8	10.000	.000	10.000	5.000	LREF 50.8000 FT.
(RBJ007)	AMES 97-616 IA2 01 TO S1 SRM A/A=12, GRB NOM	.000	.000	.000	5.000	BREF 73.5000 FT.
(RBJ017)	AMES 97-616 IA2 01 TO S1 SRM A/A=12, GRB NOM	10.000	.000	10.000	5.000	XMRP 86.4167 FT.
(RBJ009)	AMES 97-616 IA2 01 TO S1 PC/PT=1.3 NOMINAL	.000	.000	.000	5.000	YMRP .0000 FT.
(RBJ019)	AMES 97-616 IA2 01 TO S1 PC/PT=1.3 NOMINAL	10.000	.000	10.000	5.000	ZMRP 4.0000 FT.
						SCALE .0190

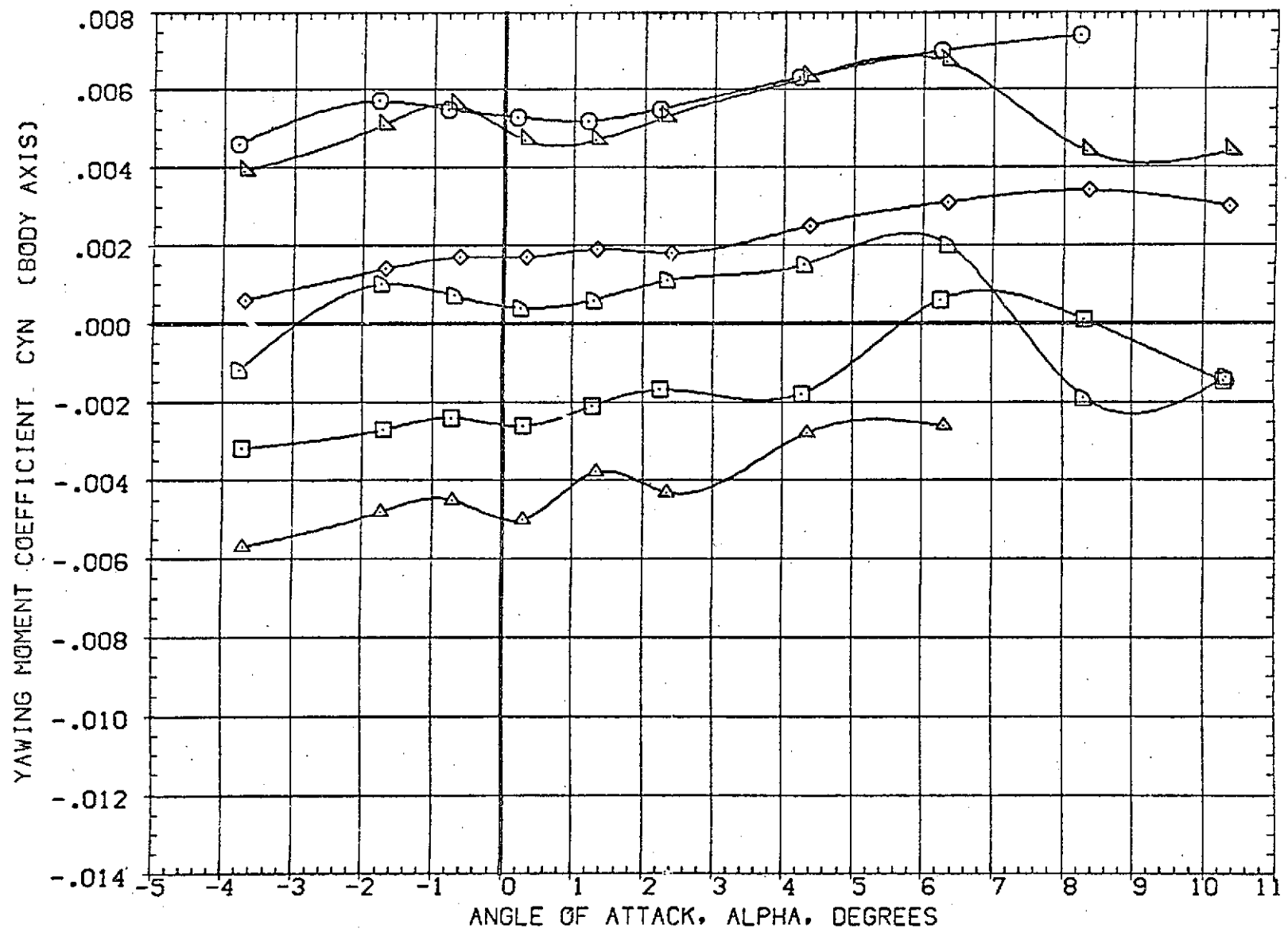

FIG 21 EFFECT OF PLUME SIZE ON ELEVON AND RUDDER POWER, BETA=0.0

(B)MACH = 1.98

DATA SET SYMBOL	CONFIGURATION DESCRIPTION	ELEVON	AILRON	RUDDER	PLUMES	REFERENCE INFORMATION
(DBJ001)	AMES 97-616 1A2 01 TO S1 PC/PT-NOM.SRM A/A=8	.000	.000	.000	5.000	SREF 3155.0000 SQ.FT.
(DBJ011)	AMES 97-616 1A2 01 TO S1 PC/PT-NOM.SRM A/A=8	10.000	.000	10.000	5.000	LREF 50.8000 FT.
(RBJ007)	AMES 97-616 1A2 01 TO S1 SRM A/A=12.0RB NOM	.000	.000	.000	5.000	BREF 73.5000 FT.
(RBJ017)	AMES 97-616 1A2 01 TO S1 SRM A/A=12.0RB NOM	10.000	.000	10.000	5.000	XMRP 86.4167 FT.
(RBJ009)	AMES 97-616 1A2 01 TO S1 PC/PT=1.3 NOMINAL	.000	.000	.000	5.000	YMRP .0000 FT.
(RBJ019)	AMES 97-616 1A2 01 TO S1 PC/PT=1.3 NOMINAL	10.000	.000	10.000	5.000	ZMRP 4.0000 FT.
						SCALE .0190

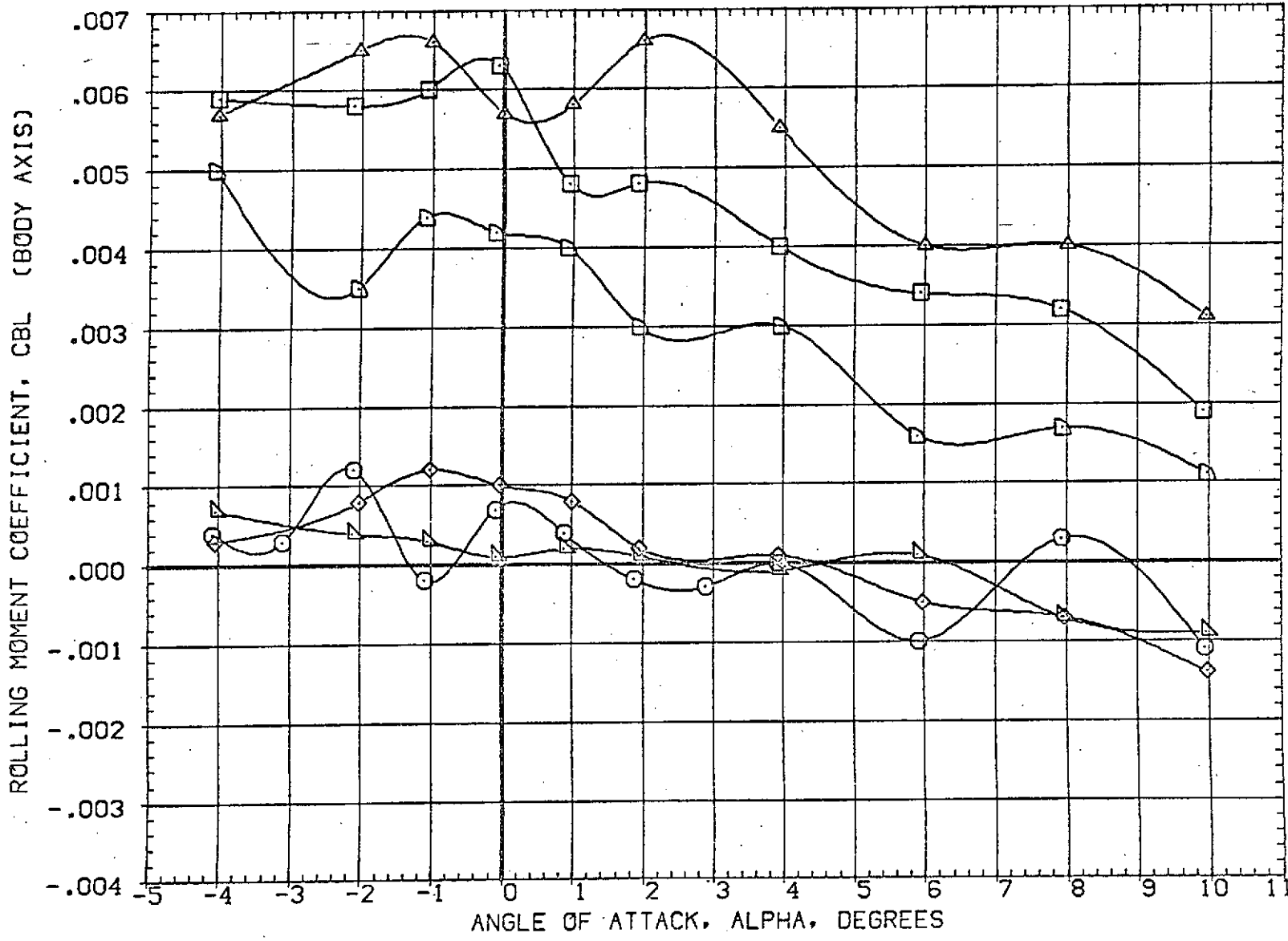

FIG 21 EFFECT OF PLUME SIZE ON ELEVON AND RUDDER POWER, BETA=0.0

(A)MACH = 1.60

DATA SET SYMBOL	CONFIGURATION DESCRIPTION	ELEVON	AILERON	RUDDER	PLUMES	REFERENCE INFORMATION
(DBJ001)	AMES 97-616 1A2 01 TO S1 PC/PT-NOM, SRM A/A=8	.000	.000	.000	5.000	SREF 3155.0000 SQ.FT.
(DBJ011)	AMES 97-616 1A2 01 TO S1 PC/PT-NOM, SRM A/A=8	10.000	.000	10.000	5.000	LREF 50.8000 FT.
(RBJ007)	AMES 97-616 1A2 01 TO S1 SRM A/A=12, CRB NOM	.000	.000	.000	5.000	BREF 73.5000 FT.
(RBJ017)	AMES 97-616 1A2 01 TO S1 SRM A/A=12, CRB NOM	10.000	.000	10.000	5.000	XMRP 86.4167 FT.
(RBJ009)	AMES 97-616 1A2 01 TO S1 PC/PT=1.3 NOMINAL	.000	.000	.000	5.000	YMRP .0000 FT.
(RBJ019)	AMES 97-616 1A2 01 TO S1 PC/PT=1.3 NOMINAL	10.000	.000	10.000	5.000	ZMRP 4.0000 FT.
						SCALE .0190

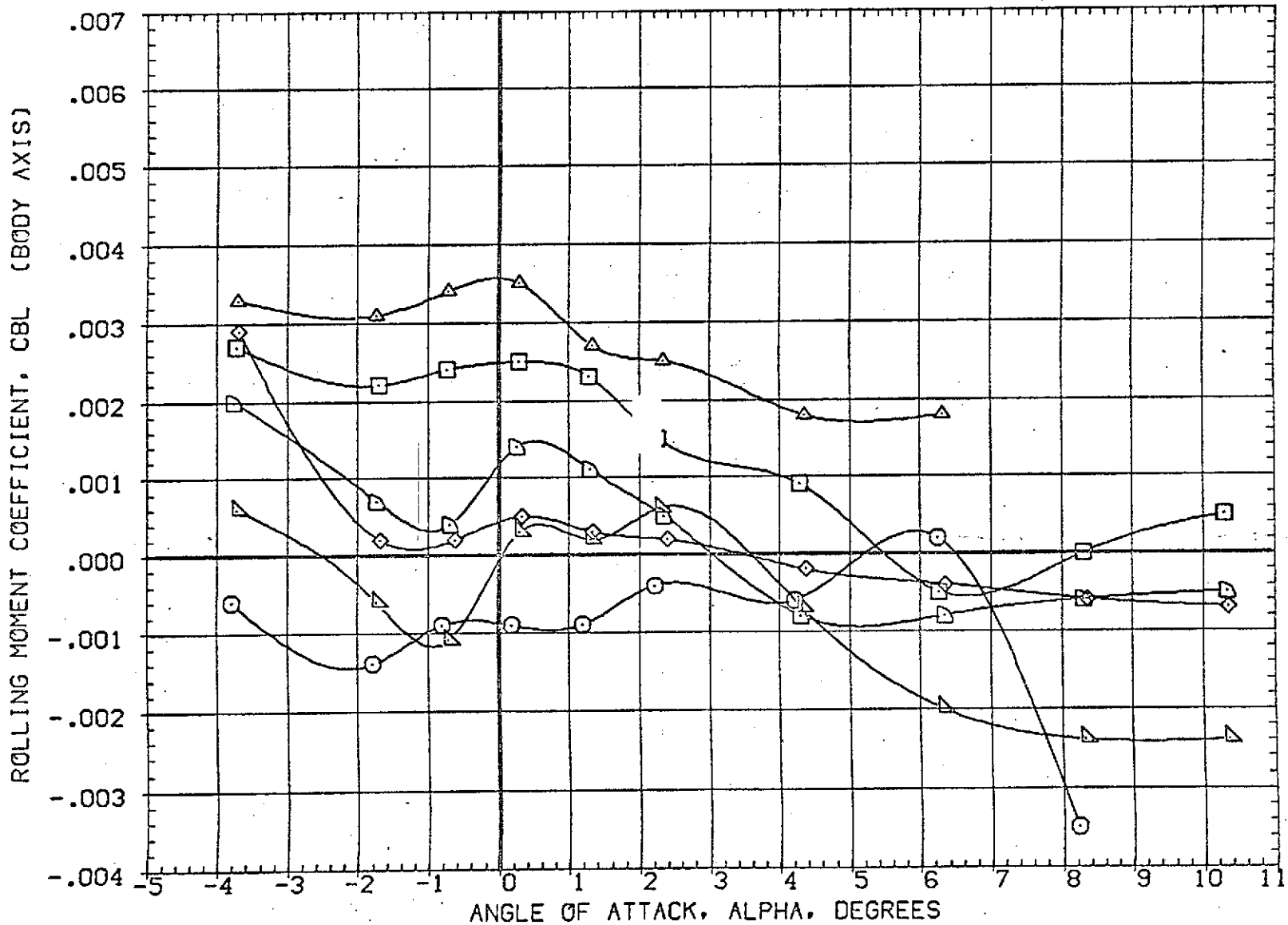

FIG 21 EFFECT OF PLUME SIZE ON ELEVON AND RUDDER POWER, BETA=0.0

(B)MACH = 1.98

DATA SET SYMBOL	CONFIGURATION DESCRIPTION	ELEVON	AILRON	RUDDER	PLUMES	REFERENCE INFORMATION
(HBJ002)	AMES 97-616 IA2 01 TO S1 PC/PT NOM. SRM A/A=8	.000	.000	.000	5.000	SREF 3155.0000 SQ.FT.
(DBJ012)	AMES 97-616 IA2 01 TO S1 PC/PT=NOM. SRM A/A=8	10.000	.000	10.000	5.000	LREF 50.8000 FT.
(RBJ008)	AMES 97-616 IA2 01 TO S1 SRM A/A=12.0RB NOM	.000	.000	.000	5.000	BREF 73.5000 FT.
(RBJ018)	AMES 97-616 IA2 01 TO S1 SRM A/A=12.0RB NOM	10.000	.000	10.000	5.000	XMRP 86.4167 FT.
(RBJ010)	AMES 97-616 IA2 01 TO S1 PC/PT=1.3 NOMINAL	.000	.000	.000	5.000	YMRP .0000 FT.
(RBJ020)	AMES 97-616 IA2 01 TO S1 PC/PT=1.3 NOMINAL	10.000	.000	10.000	5.000	ZMRP 4.0000 FT.
						SCALE .0190

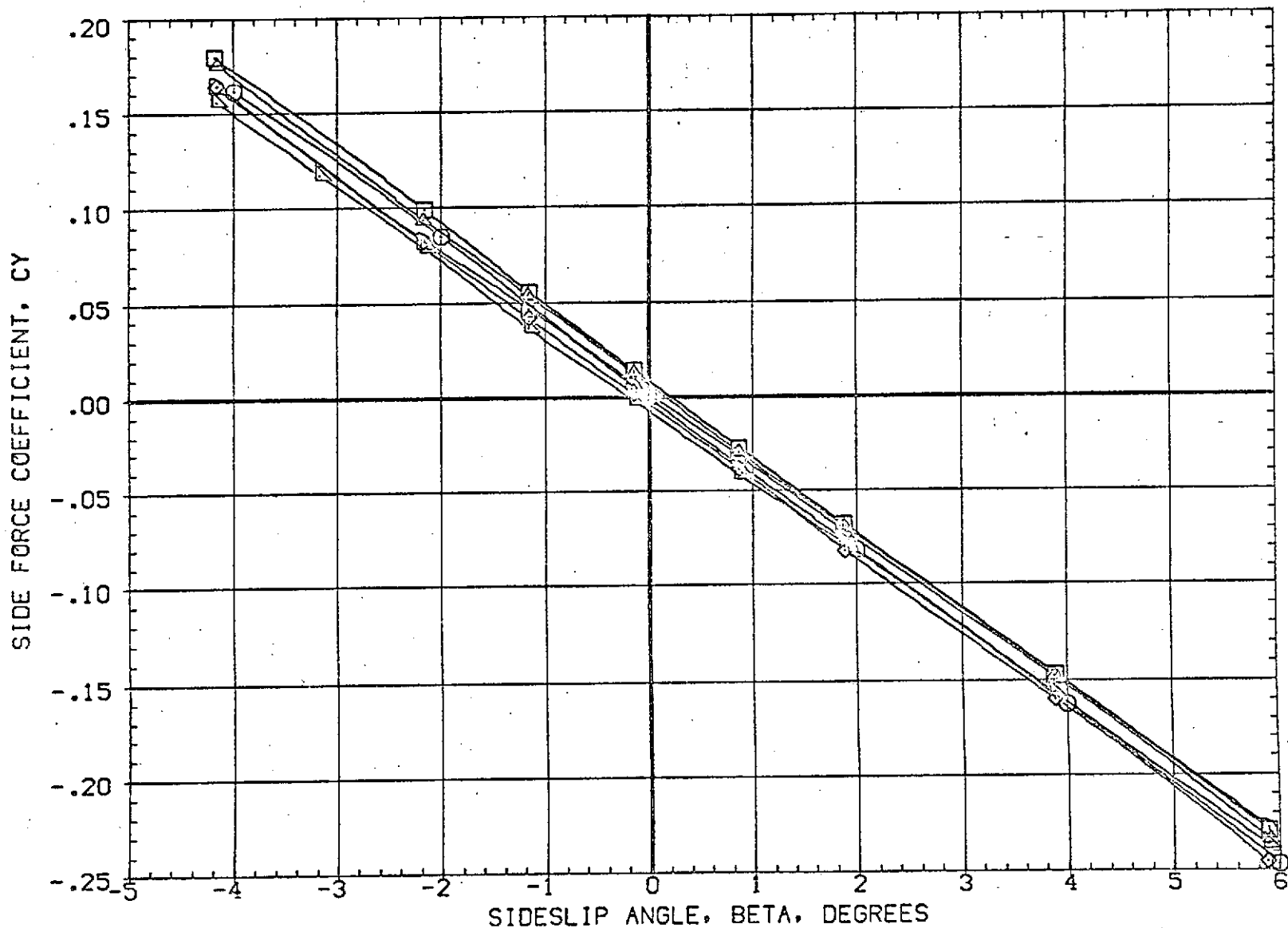

FIG 22 EFFECT OF PLUME SIZE ON ELEVON AND RUDDER POWER, ALPHA=0.0

(A)MACH = 1.60

DATA SET SYMBOL	CONFIGURATION DESCRIPTION	ELEVON	AILERON	RUDDER	PLUMES	REFERENCE INFORMATION
(HBJ002)	AMES 97-616 1A2 01 TO S1 PC/PT NOM, SRM A/A=8	.000	.000	.000	5.000	SREF 3155.0000 SQ.FT.
(RBJ012)	AMES 97-616 1A2 01 TO S1 PC/PT=NOM, SRM A/A=8	10.000	.000	10.000	5.000	LREF 50.8000 FT.
(RBJ008)	AMES 97-616 1A2 01 TO S1 SRM A/A=12.0RB NOM	.000	.000	.000	5.000	BREF 73.5000 FT.
(RBJ018)	AMES 97-616 1A2 01 TO S1 SRM A/A=12.0RB NOM	10.000	.000	10.000	5.000	XMRF 86.4167 FT.
(RBJ010)	AMES 97-616 1A2 01 TO S1 PC/PT=1.3 NOMINAL	.000	.000	.000	5.000	YMRF .0000 FT.
(RBJ020)	AMES 97-616 1A2 01 TO S1 PC/PT=1.3 NOMINAL	10.000	.000	10.000	5.000	ZMRF 4.0000 FT.
						SCALE .0190

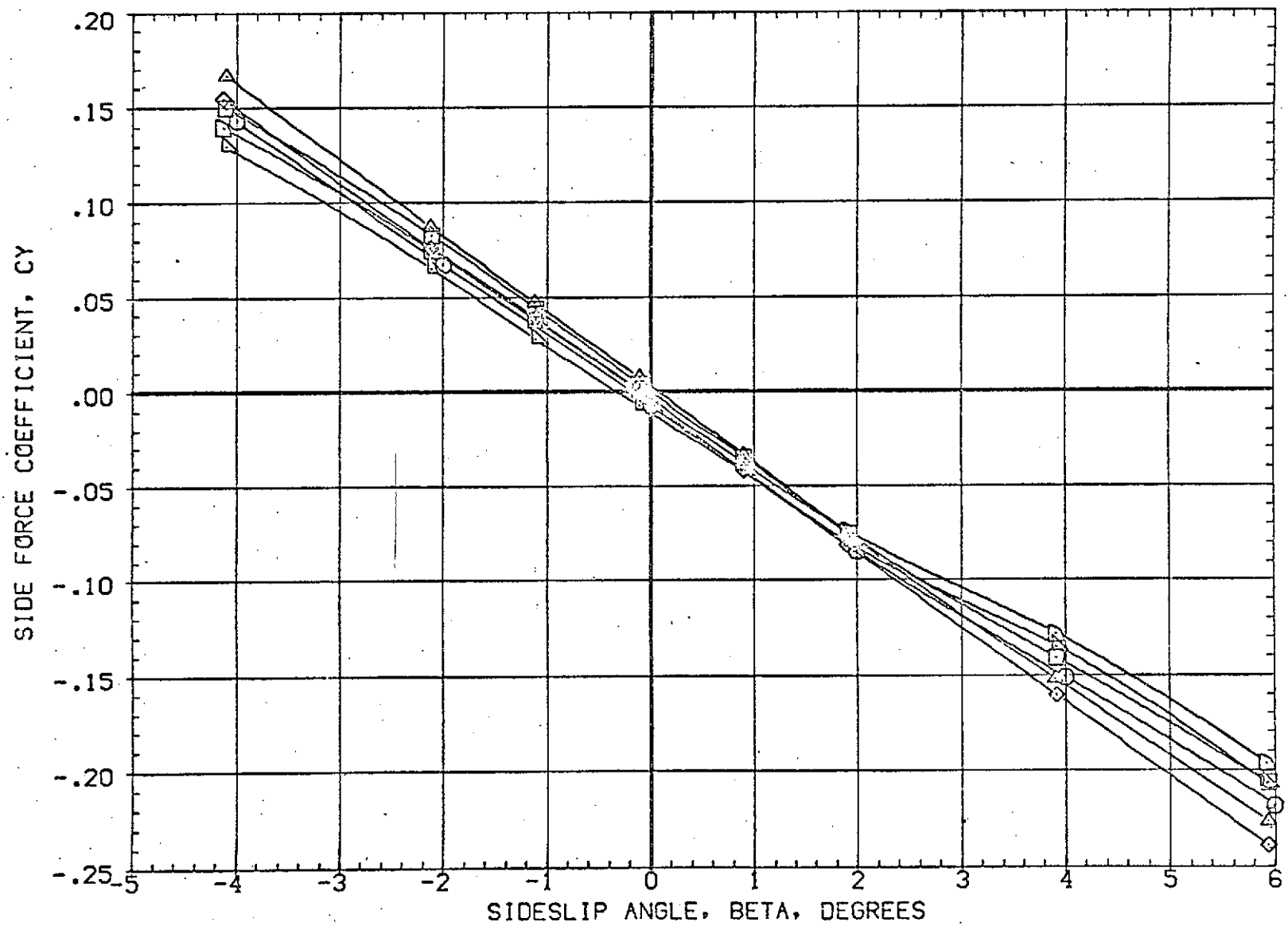

FIG 22 EFFECT OF PLUME SIZE ON ELEVON AND RUDDER POWER, ALPHA=0.0
 (B)MACH = 2.00

DATA SET SYMBOL	CONFIGURATION DESCRIPTION	ELEVON	AILRON	RUDDER	PLUMES	REFERENCE INFORMATION		
(HBJ002)	AMES 97-616 IA2 01 TO S1 PC/PT NOM. SRM A/A=8	.000	.000	.000	5.000	SREF	3155.0000	50.FT.
(CBJ012)	AMES 97-616 IA2 01 TO S1 PC/PT=NOM. SRM A/A=8	10.000	.000	10.000	5.000	LREF	50.8000	FT.
(RBJ008)	AMES 97-616 IA2 01 TO S1 SRM A/A=12. ORB NOM	.000	.000	.000	5.000	BREF	73.5000	FT.
(RBJ018)	AMES 97-616 IA2 01 TO S1 SRM A/A=12. ORB NOM	10.000	.000	10.000	5.000	XMRP	86.4167	FT.
(RBJ010)	AMES 97-616 IA2 01 TO S1 PC/PT=1.3 NOMINAL	.000	.000	.000	5.000	YMRP	.0000	FT.
(RBJ020)	AMES 97-616 IA2 01 TO S1 PC/PT=1.3 NOMINAL	10.000	.000	10.000	5.000	ZMRP	4.0000	FT.
						SCALE	.0190	

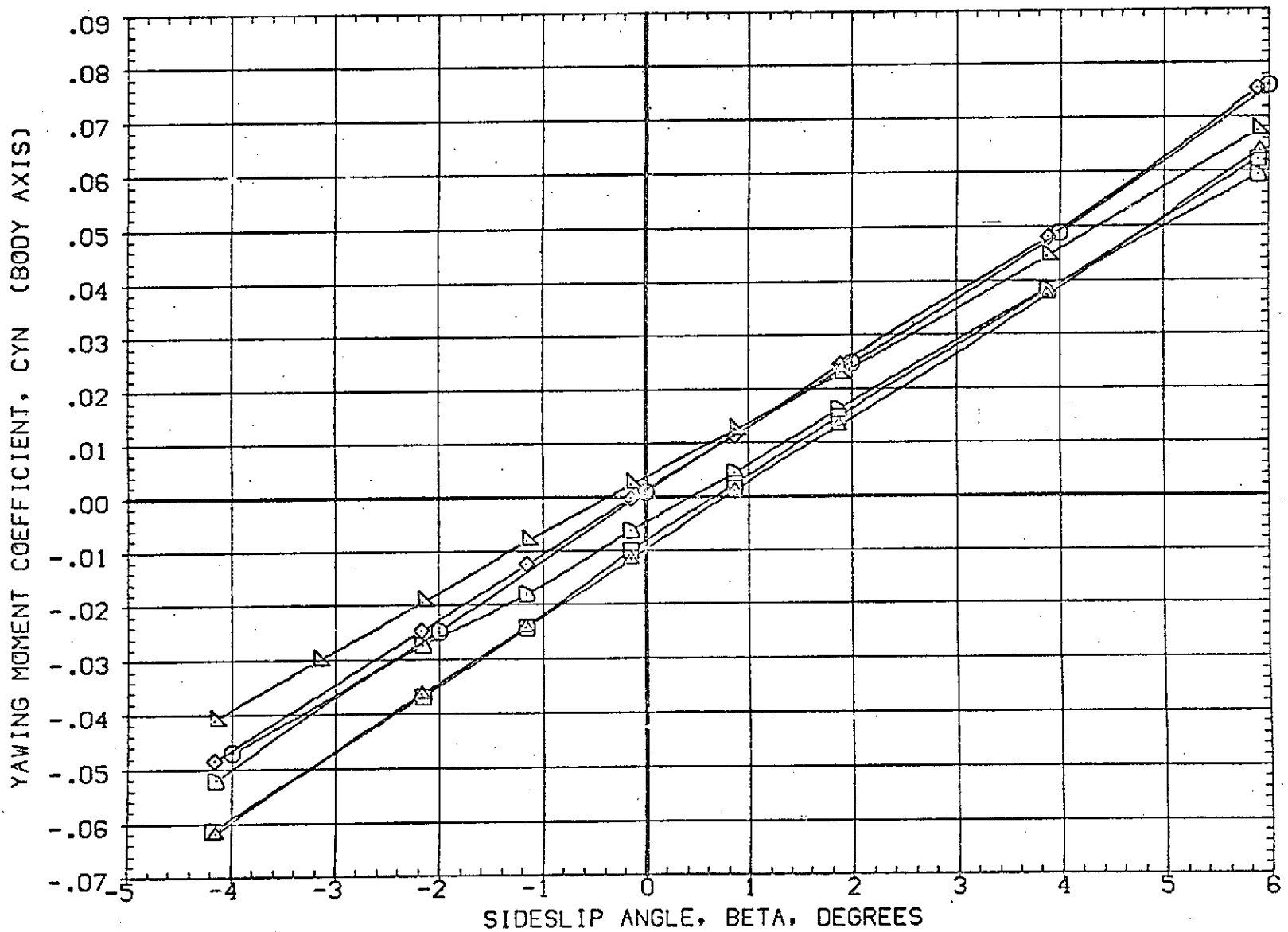

FIG 22 EFFECT OF PLUME SIZE ON ELEVON AND RUDDER POWER, ALPHA=0.0

DATA SET SYMBOL	CONFIGURATION DESCRIPTION	ELEVON	AILRON	RUDDER	PLUMES	REFERENCE INFORMATION
(RBJ002)	AMES 97-616 IA2 01 TO S1 PC/PT NOM. SRM A/A=8	.000	.000	.000	5.000	SREF 3155.0000 SQ.FT.
(DBJ012)	AMES 97-616 IA2 01 TO S1 PC/PT=NOM. SRM A/A=8	10.000	.000	10.000	5.000	LREF 50.8000 FT.
(RBJ008)	AMES 97-616 IA2 01 TO S1 SRM A/A=12.0RB NOM	.000	.000	.000	5.000	BREF 73.5000 FT.
(RBJ018)	AMES 97-616 IA2 01 TO S1 SRM A/A=12.0RB NOM	10.000	.000	10.000	5.000	XMRP 86.4167 FT.
(RBJ010)	AMES 97-616 IA2 01 TO S1 PC/PT=1.3 NOMINAL	.000	.000	.000	5.000	YMRP .0000 FT.
(RBJ020)	AMES 97-616 IA2 01 TO S1 PC/PT=1.3 NOMINAL	10.000	.000	10.000	5.000	ZMRP 4.0000 FT.
						SCALE .0190

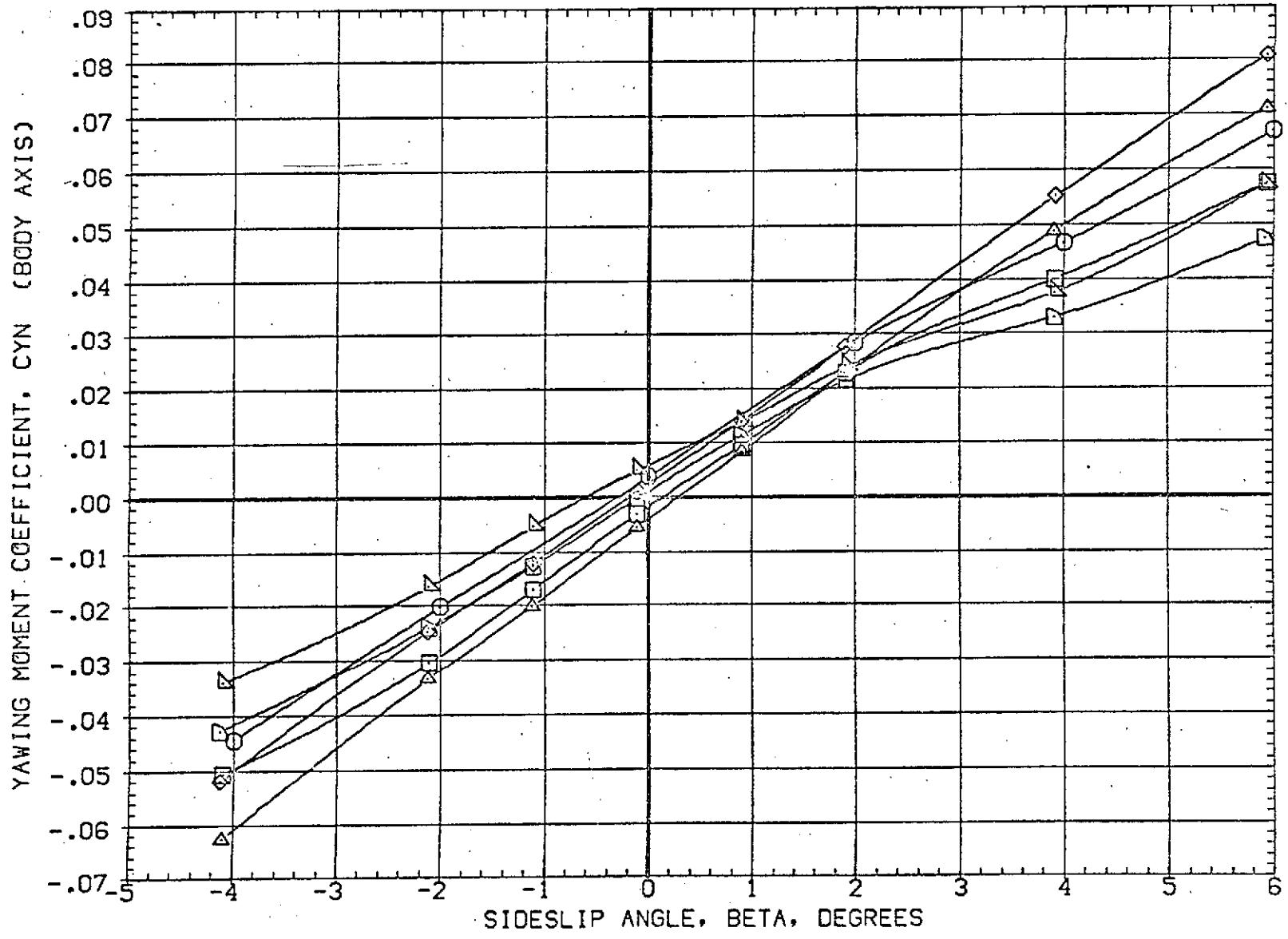

FIG 22 EFFECT OF PLUME SIZE ON ELEVON AND RUDDER POWER, ALPHA=0.0

(B)MACH = 2.00

DATA SET SYMBOL	CONFIGURATION DESCRIPTION	ELEVON	AILRON	RUDDER	PLUMES	REFERENCE INFORMATION		
(HBJ002)	AMES 97-616 IA2 01 TO S1 PC/PT-NOM,SRM A/A=8	.000	.000	.000	5.000	SREF	3155.0000	SQ.FT.
(DBJ012)	AMES 97-616 IA2 01 TO S1 PC/PT-NOM,SRM A/A=8	10.000	.000	10.000	5.000	LREF	50.8000	FT.
(RBJ008)	AMES 97-616 IA2 01 TO S1 SRM A/A=12,CRB NOM	.000	.000	.000	5.000	BREF	73.5000	FT.
(RBJ018)	AMES 97-616 IA2 01 TO S1 SRM A/A=12,CRB NOM	10.000	.000	10.000	5.000	XMRP	86.4167	FT.
(RBJ010)	AMES 97-616 IA2 01 TO S1 PC/PT=1.3 NOMINAL	.050	.000	.000	5.000	YMRP	.0000	FT.
(RBJ020)	AMES 97-616 IA2 01 TO S1 PC/PT=1.3 NOMINAL	10.000	.000	10.000	5.000	ZMRP	4.0000	FT.
						SCALE	.0190	

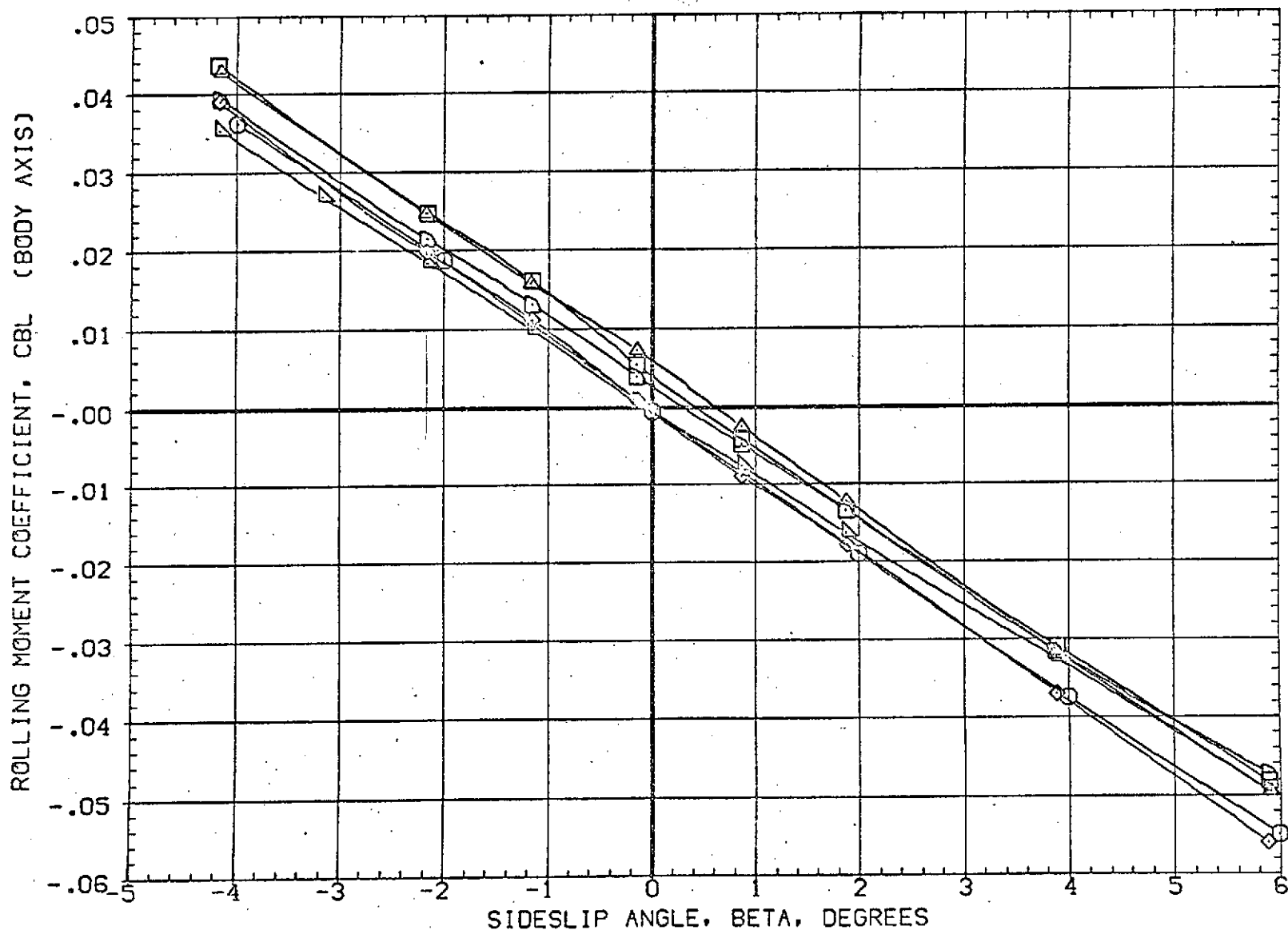

FIG 22 EFFECT OF PLUME SIZE ON ELEVON AND RUDDER POWER, ALPHA=0.0

(A)MACH = 1.60

DATA SET SYMBOL	CONFIGURATION DESCRIPTION	ELEVON	AILERON	RUDDER	PLUMES	REFERENCE INFORMATION
(HBJ002)	AMES 97-616 1A2 01 TO S1 PC/PT-NOM.SRM A/A=8	.000	.000	.000	5.000	SREF 3155.0000 SQ.FT.
(RBJ012)	AMES 97-616 1A2 01 TO S1 PC/PT-NOM.SRM A/A=8	10.000	.000	10.000	5.000	LREF 50.8000 FT.
(RBJ008)	AMES 97-616 1A2 01 TO S1 SRM A/A=12,CRB NOM	.000	.000	.000	5.000	BREF 73.5000 FT.
(RBJ018)	AMES 97-616 1A2 01 TO S1 SRM A/A=12,CRB NOM	10.000	.000	10.000	5.000	XMRP 86.4167 FT.
(RBJ010)	AMES 97-616 1A2 01 TO S1 PC/PT=1.3 NOMINAL	.000	.000	.000	5.000	YMRP .0000 FT.
(RBJ020)	AMES 97-616 1A2 01 TO S1 PC/PT=1.3 NOMINAL	10.000	.000	10.000	5.000	ZMRP 4.0000 FT.
						SCALE .0190

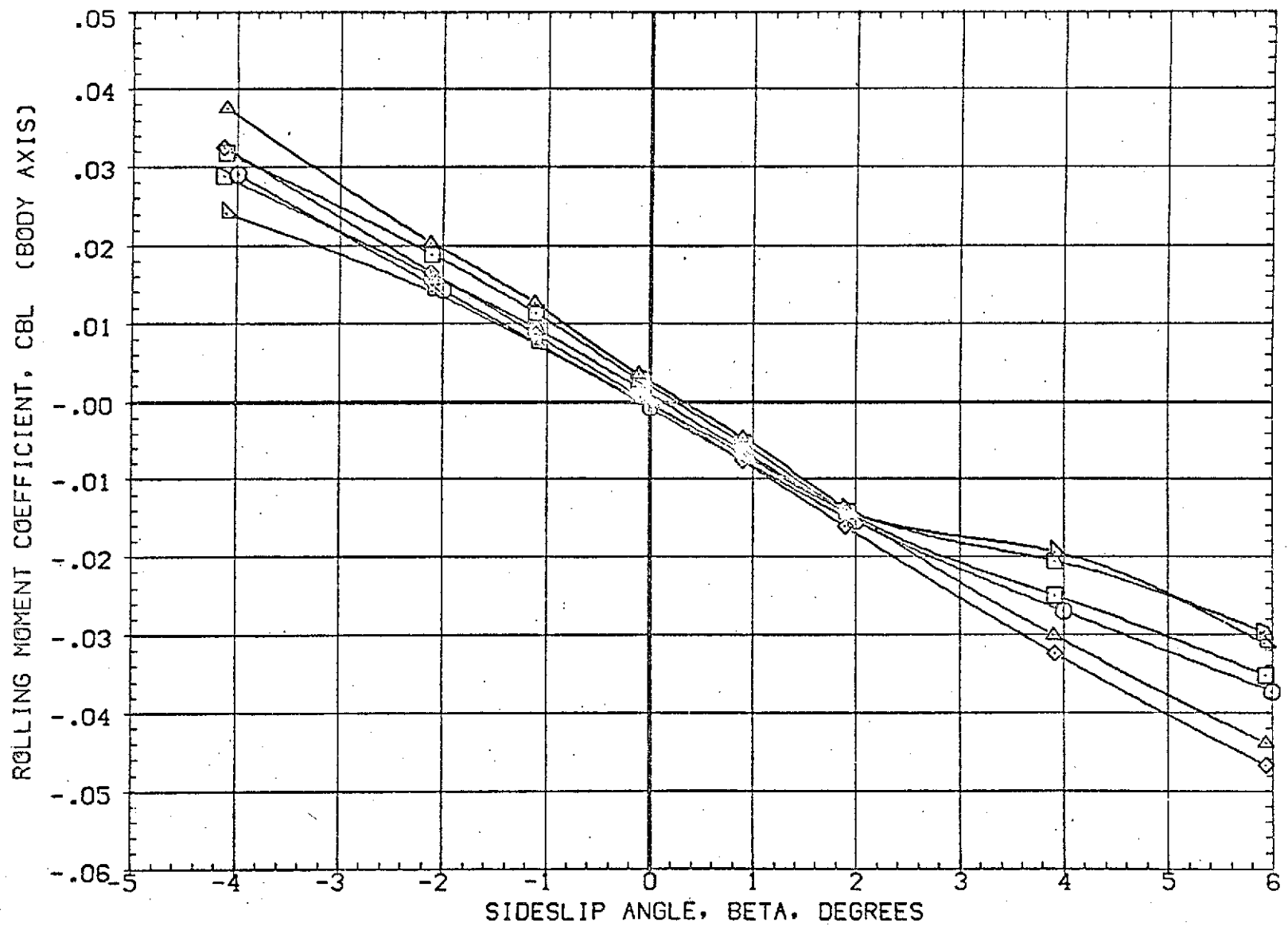

FIG 22 EFFECT OF PLUME SIZE ON ELEVON AND RUDDER POWER, ALPHA=0.0

(B)MACH = 2.00

DATA SET SYMBOL	CONFIGURATION DESCRIPTION	ELEVON	AILRON	RUDDER	PLUMES	REFERENCE INFORMATION
(HBJ002)	AMES 97-616 1A2 01 TO S1 PC/PT NOM. SRM A/A=8	.000	.000	.000	5.000	SREF 3155.0000 SQ.FT.
(DBJ012)	AMES 97-616 1A2 01 TO S1 PC/PT=NOM. SRM A/A=8	10.000	.000	10.000	5.000	LREF 50.8000 FT.
(RBJ008)	AMES 97-616 1A2 01 TO S1 SRM A/A=12. CRB NOM	.000	.000	.000	5.000	BREF 73.5000 FT.
(RBJ018)	AMES 97-616 1A2 01 TO S1 SRM A/A=12. CRB NOM	10.000	.000	10.000	5.000	XMRP 86.4167 FT.
(RBJ010)	AMES 97-616 1A2 01 TO S1 PC/PT=1.3 NOMINAL	.000	.000	.000	5.000	YMRP 1.0000 FT.
(RBJ020)	AMES 97-616 1A2 01 TO S1 PC/PT=1.3 NOMINAL	10.000	.000	10.000	5.000	ZMRP 4.0000 FT.
						SCALE .0190

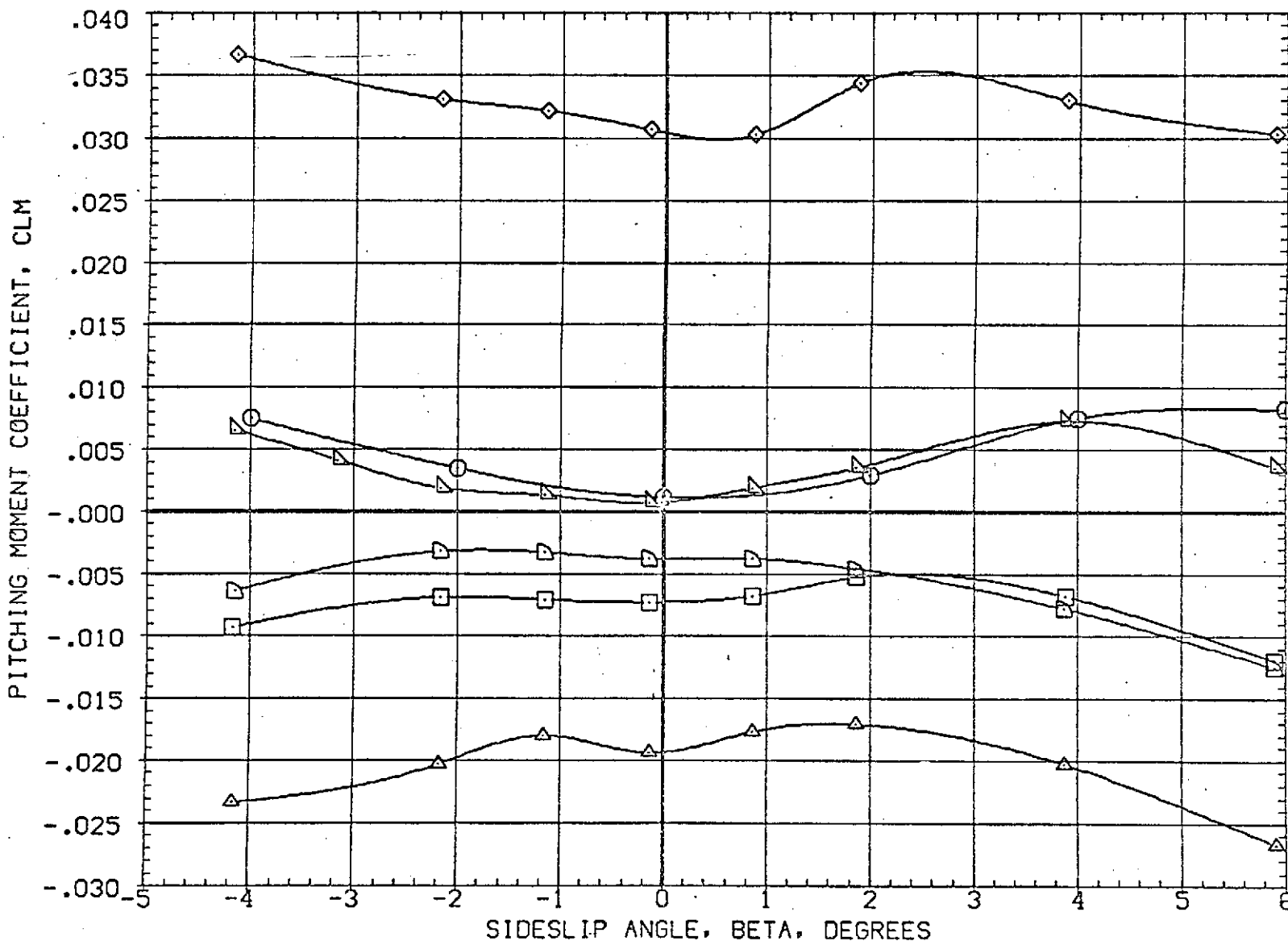

FIG 22 EFFECT OF PLUME SIZE ON ELEVON AND RUDDER POWER, ALPHA=0.0

(A)MACH = 1.60

DATA SET SYMBOL	CONFIGURATION DESCRIPTION	ELEVON	AILRON	RUDDER	PLUMES	REFERENCE INFORMATION
(HBJ002)	AMES 97-616 IA2 01 TO S1 PC/PT NOM. SRM A/A=8	.000	.000	.000	5.000	SREF 3155.0000 SQ. FT.
(DBJ012)	AMES 97-616 IA2 01 TO S1 PC/PT=NOM. SRM A/A=8	10.000	.000	10.000	5.000	LREF 50.8000 FT.
(R9J008)	AMES 97-616 IA2 01 TO S1 SRM A/A=12.0RB NOM	.000	.000	.000	5.000	BREF 73.5000 FT.
(RBJ018)	AMES 97-616 IA2 01 TO S1 SRM A/A=12.0RB NOM	10.000	.000	10.000	5.000	XMRP 86.4167 FT.
(RBJ010)	AMES 97-616 IA2 01 TO S1 PC/PT=1.3 NOMINAL	.000	.000	.000	5.000	YMRP .0000 FT.
(RBJ020)	AMES 97-616 IA2 01 TO S1 PC/PT=1.3 NOMINAL	10.000	.000	10.000	5.000	ZMRP 4.0000 FT.
						SCALE .0190

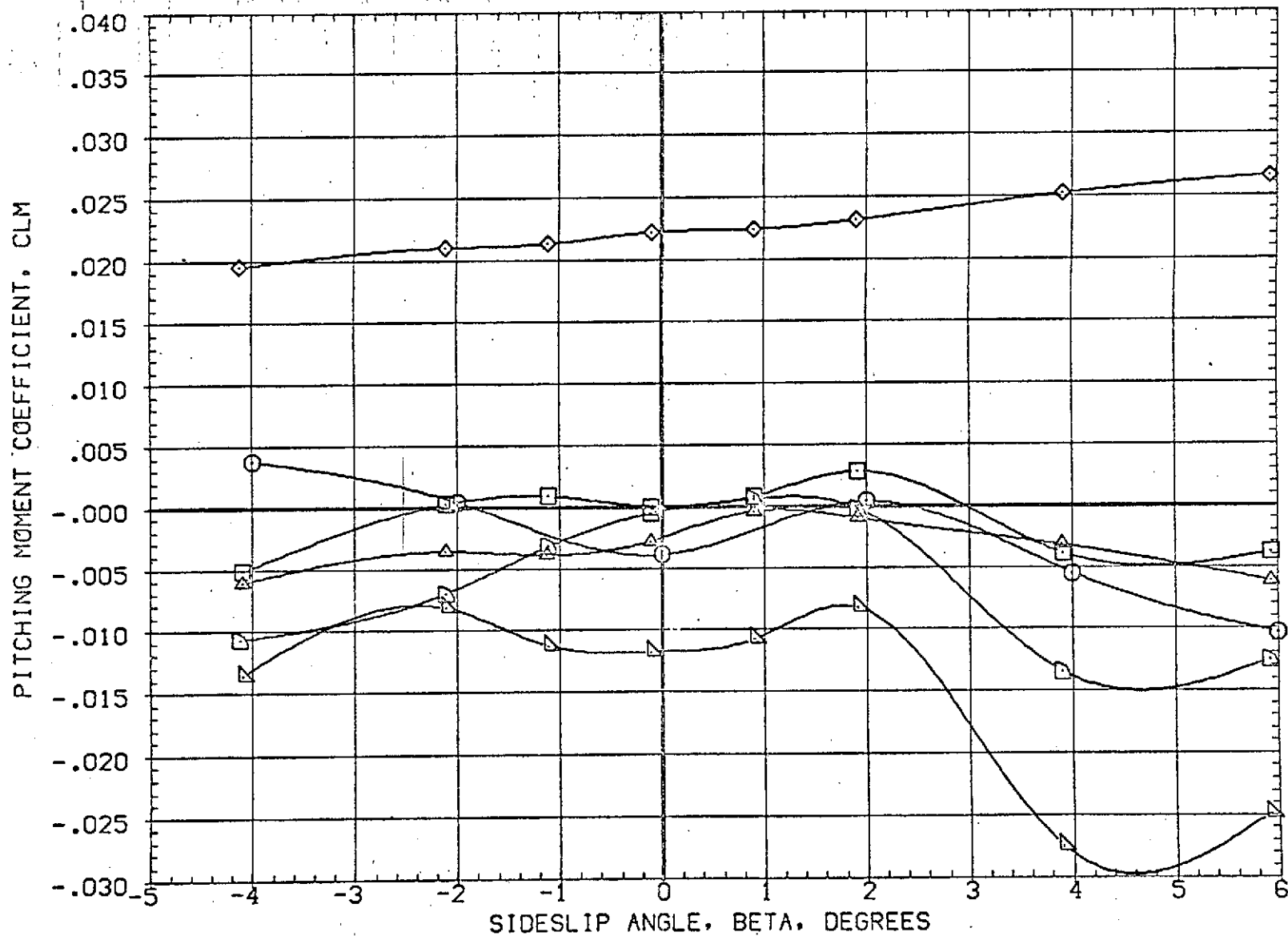

FIG 22 EFFECT OF PLUME SIZE ON ELEVON AND RUDDER POWER, ALPHA=0.0

(B)MACH = 2.00

DATA SET SYMBOL	CONFIGURATION DESCRIPTION	ELEVON	AILRON	RUDDER	PLUMES	REFERENCE INFORMATION
(RBJ002)	AMES 97-616 1A2 01 TO S1 PC/PT NOM, SRM A/A=8	.000	.000	.000	5.000	SREF 3155.0000 SQ.FT.
(RBJ012)	AMES 97-616 1A2 01 TO S1 PC/PT=NOM, SRM A/A=8	10.000	.000	10.000	5.000	LREF 50.8000 FT.
(RBJ008)	AMES 97-616 1A2 01 TO S1 SRM A/A=12, ORB NOM	.000	.000	.000	5.000	BREF 73.5000 FT.
(RBJ018)	AMES 97-616 1A2 01 TO S1 SRM A/A=12, ORB NOM	10.000	.000	10.000	5.000	XMRP 86.4167 FT.
(RBJ010)	AMES 97-616 1A2 01 TO S1 PC/PT=1.3 NOMINAL	.000	.000	.000	5.000	YMRP .0000 FT.
(RBJ020)	AMES 97-616 1A2 01 TO S1 PC/PT=1.3 NOMINAL	10.000	.000	10.000	5.000	ZMRP 4.0000 FT.
						SCALE .0190

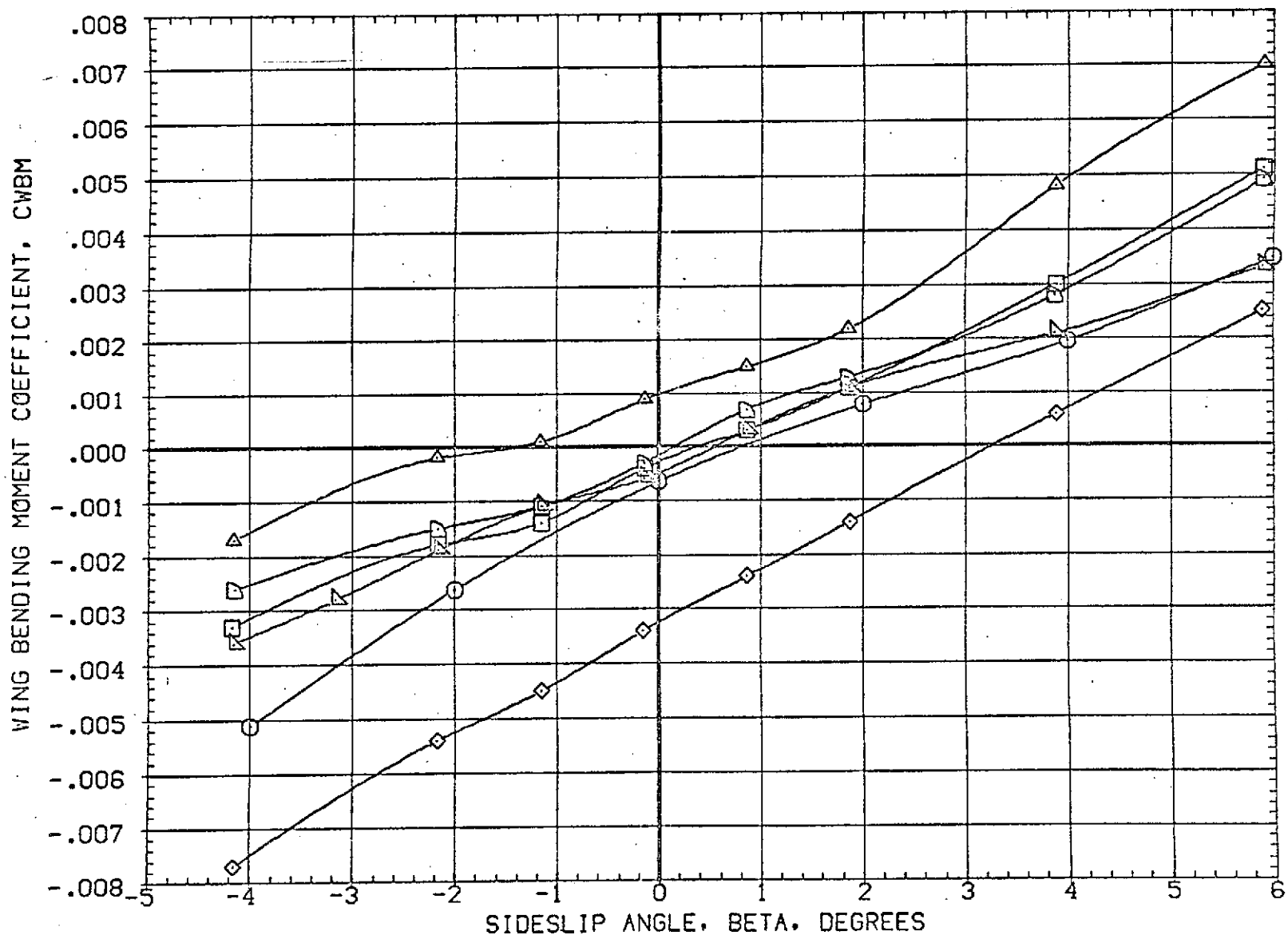

FIG 22 EFFECT OF PLUME SIZE ON ELEVON AND RUDDER POWER, ALPHA=0.0

(A)MACH = 1.60

DATA SET SYMBOL	CONFIGURATION DESCRIPTION	ELEVON	AILRON	RUDDER	PLUMES	REFERENCE INFORMATION
(HBW002)	AMES 97-616 IA2 01 TO S1 PC/PT NOM. SRM A/A=8	.000	.000	.000	5.000	SREF 3155.0000 SQ.FT.
(DBJ012)	AMES 97-616 IA2 01 TO S1 PC/PT=NOM. SRM A/A=8	10.000	.000	10.000	5.000	LREF 50.8000 FT.
(RBW008)	AMES 97-616 IA2 01 TO S1 SRM A/A=12. CRB NOM	.000	.000	.000	5.000	BREF 73.5000 FT.
(RBW018)	AMES 97-616 IA2 01 TO S1 SRM A/A=12. CRB NOM	10.000	.000	10.000	5.000	XMRP 86.4167 FT.
(RBW010)	AMES 97-616 IA2 01 TO S1 PC/PT=1.3 NOMINAL	.000	.000	.000	5.000	YMRP .0000 FT.
(RBW020)	AMES 97-616 IA2 01 TO S1 PC/PT=1.3 NOMINAL	10.000	.000	10.000	5.000	ZMRP 4.0000 FT.
						SCALE .0190

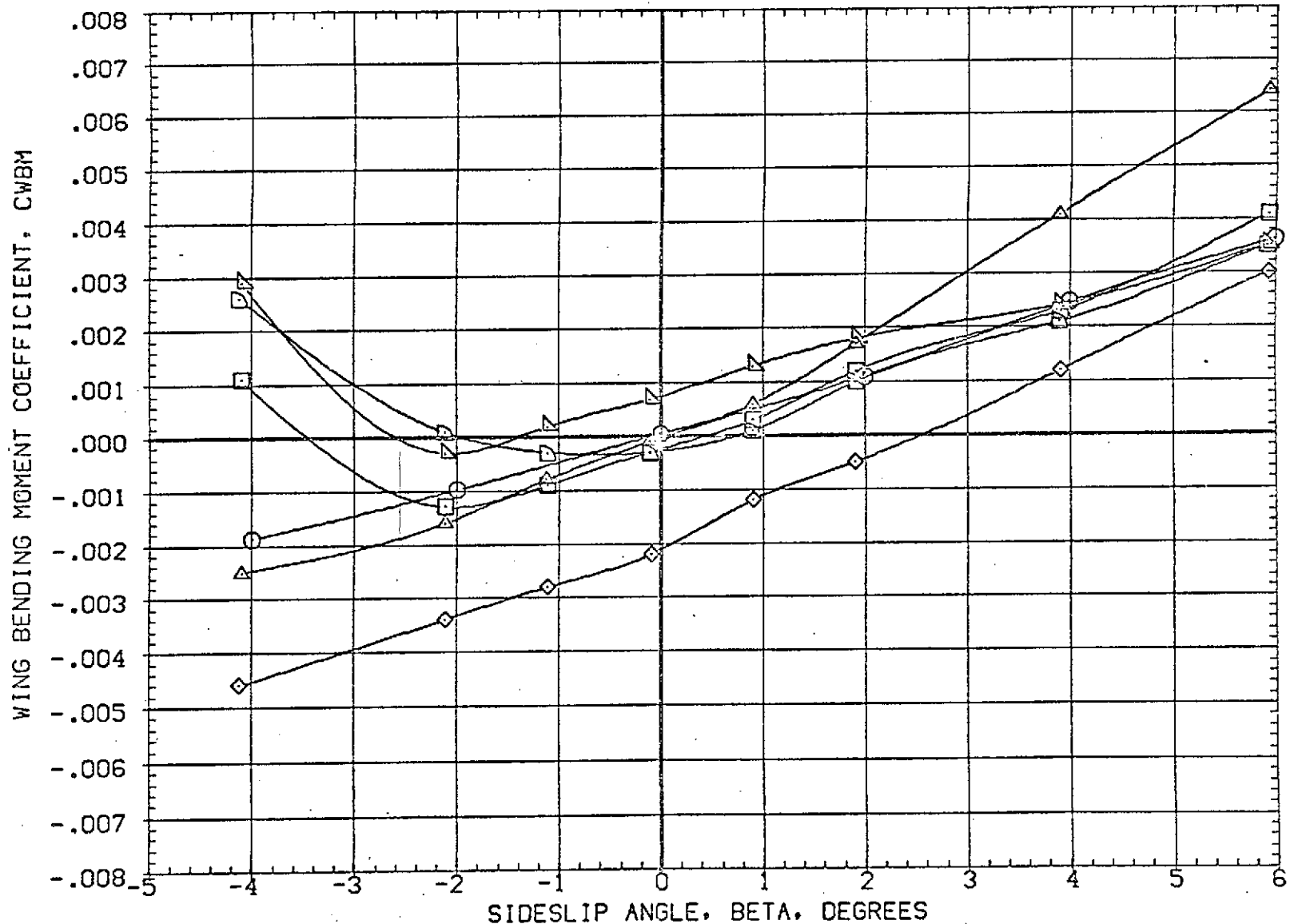

FIG 22 EFFECT OF PLUME SIZE ON ELEVON AND RUDDER POWER, ALPHA=0.0

(B)MACH = 2.00

DATA SET SYMBOL	CONFIGURATION DESCRIPTION	ELEVON	AILERON	RUDDER	PLUMES	REFERENCE INFORMATION
(DBJ501)	AMES 97-616 1A2 01 TO S1 NO PLUMES	.000	.000	.000	.000	SREF 3155.0000 SQ.FT.
(DBJ511)	AMES 97-616 1A2 01 TO S1 NO PLUMES	10.000	.000	10.000	.000	LREF 50.8000 FT.
(RBJ003)	AMES 97-616 1A2 01 TO S1 PC/PT NOM, SRM A/A=8	.000	.000	.000	2.000	BREF 73.5000 FT.
(RBJ013)	AMES 97-616 1A2 01 TO S1 PC/PT=NOM, SRM A/A=8	10.000	.000	10.000	2.000	XMRP 86.4167 FT.
(DBJ005)	AMES 97-616 1A2 01 TO S1 PC/PT NOM	.000	.000	.000	3.000	YMRP .0000 FT.
(DBJ015)	AMES 97-616 1A2 01 TO S1 PC/PT NOM	10.000	.000	10.000	3.000	ZMRP 4.0000 FT.
						SCALE .0190

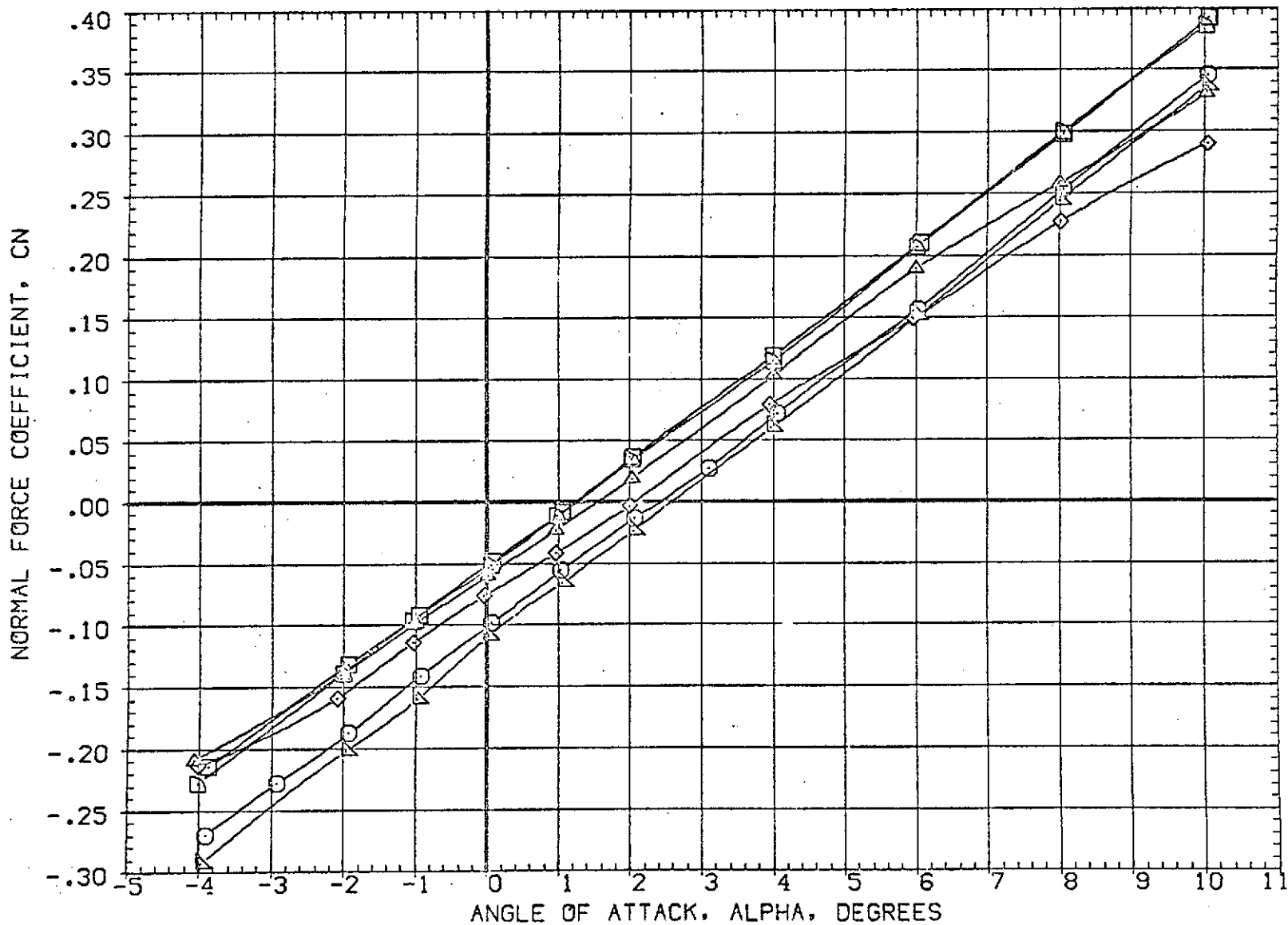

FIG 23 EFFECT OF ORBITER AND SRM PLUMES ON ELEVON AND RUDDER POWER, BETA=0.0
 (A)MACH = 1.60

DATA SET SYMBOL	CONFIGURATION DESCRIPTION	ELEVON	AILRON	RUDDER	PLUMES	REFERENCE INFORMATION		
(OBJ501)	AMES 97-616 IA2 01 TO S1 NO PLUMES	.000	.000	.000	.000	SREF	3155.0000	SQ.FT.
(OBJ511)	AMES 97-616 IA2 01 TO S1 NO PLUMES	10.000	.000	10.000	.000	LREF	50.8000	FT.
(RBJ003)	AMES 97-616 IA2 01 TO S1 PC/PT NOM. SRM A/A-8	.000	.000	.000	2.000	BREF	73.5000	FT.
(RBJ013)	AMES 97-616 IA2 01 TO S1 PC/PT NOM. SRM A/A-8	10.000	.000	10.000	2.000	XMRP	86.4167	FT.
(OBJ005)	AMES 97-616 IA2 01 TO S1 PC/PT NOM	.000	.000	.000	3.000	YMRP	.0000	FT.
(OBJ015)	AMES 97-616 IA2 01 TO S1 PC/PT NOM	10.000	.000	10.000	3.000	ZMRP	4.0000	FT.
						SCALE	.0190	

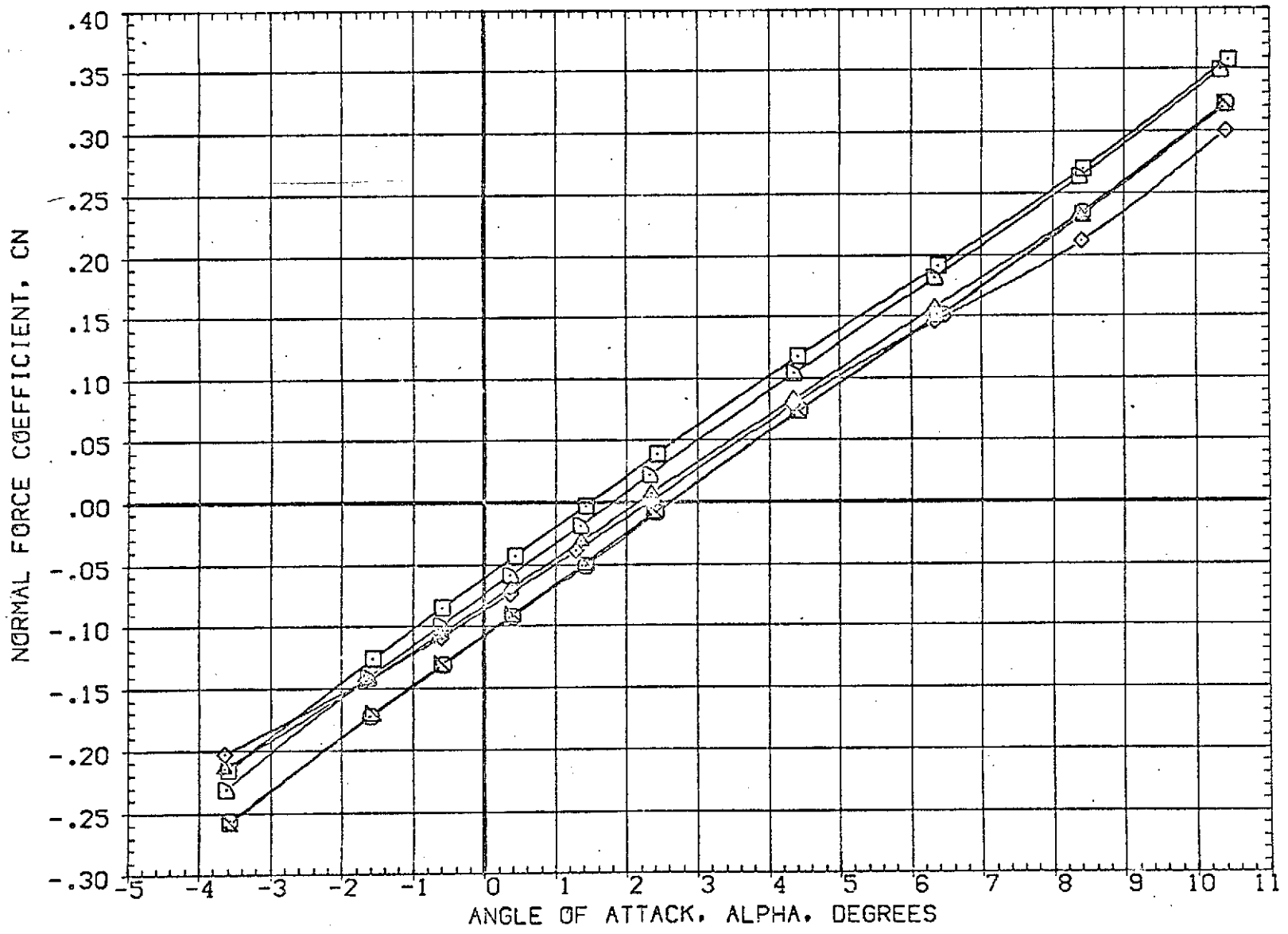

FIG 23 EFFECT OF ORBITER AND SRM PLUMES ON ELEVON AND RUDDER POWER, BETA=0.0

(B)MACH = 1.98

DATA SET SYMBOL	CONFIGURATION DESCRIPTION	ELEVON	AILRON	RUDDER	PLUMES	REFERENCE INFORMATION
(DBJ501)	AMES 97-616 1A2 01 TO S1 NO PLUMES	.000	.000	.000	.000	SREF 3155.0000 SQ.FT.
(DBJ511)	AMES 97-616 1A2 01 TO S1 NO PLUMES	10.000	.000	10.000	.000	LREF 50.8000 FT.
(RBJ003)	AMES 97-616 1A2 01 TO S1 PC/PT NOM. SRM A/A=8	.000	.000	.000	2.000	BREF 73.5000 FT.
(RBJ013)	AMES 97-616 1A2 01 TO S1 PC/PT= NOM. SRM A/A=8	10.000	.000	10.000	2.000	XMRP 96.4167 FT.
(DBJ005)	AMES 97-616 1A2 01 TO S1 PC/PT NOM	.000	.000	.000	3.000	YMRP .0000 FT.
(DBJ015)	AMES 97-616 1A2 01 TO S1 PC/PT NOM	10.000	.000	10.000	3.000	ZMRP 4.0000 FT.
						SCALE .0190

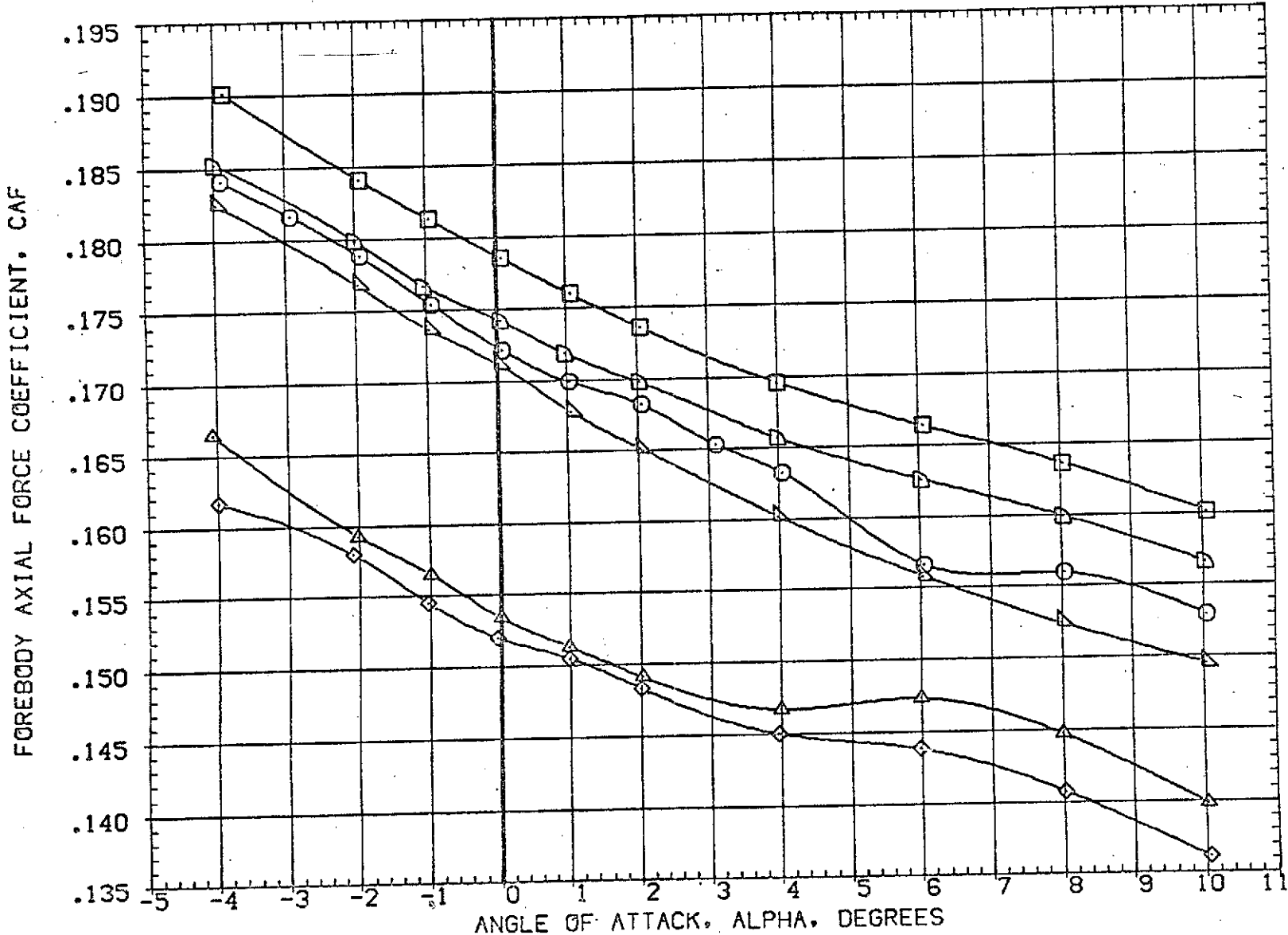

FIG 23 EFFECT OF ORBITER AND SRM PLUMES ON ELEVON AND RUDDER POWER, BETA=0.0

(A)MACH = 1.60

DATA SET SYMBOL	CONFIGURATION DESCRIPTION	ELEVON	AILRON	RUDDER	PLUMES	REFERENCE INFORMATION
(DBJ501)	AMES 97-616 1A2 01 T0 S1 NO PLUMES	.000	.000	.000	.000	SREF 3155.0000 SQ.FT.
(DBJ511)	AMES 97-616 1A2 01 T0 S1 NO PLUMES	10.000	.000	10.000	.000	LREF 50.8000 FT.
(RBJ003)	AMES 97-616 1A2 01 T0 S1 PC/PT NOM, SRM A/A=8	.000	.000	.000	2.000	BREF 73.5000 FT.
(RBJ013)	AMES 97-616 1A2 01 T0 S1 PC/PT NOM, SRM A/A=8	10.000	.000	10.000	2.000	XMRP 86.4167 FT.
(DBJ005)	AMES 97-616 1A2 01 T0 S1 PC/PT NOM	.000	.000	.000	3.000	YMRP .0000 FT.
(DBJ015)	AMES 97-616 1A2 01 T0 S1 PC/PT NOM	10.000	.000	10.000	3.000	ZMRP 4.0000 FT.
						SCALE .0190

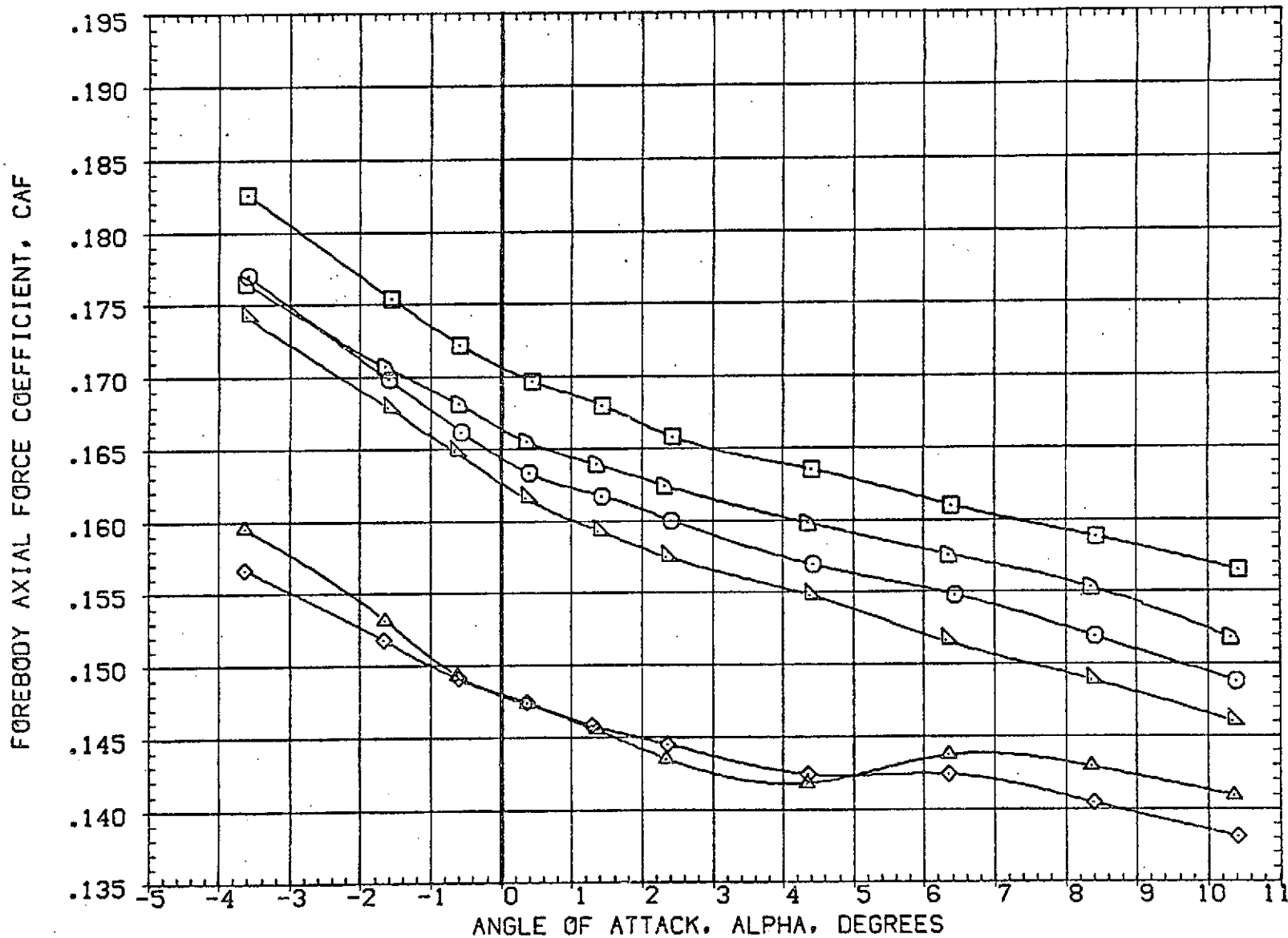

FIG 23 EFFECT OF ORBITER AND SRM PLUMES ON ELEVON AND RUDDER POWER, BETA=0.0

(B)MACH = 1.98

DATA SET SYMBOL	CONFIGURATION DESCRIPTION	ELEVON	AILERON	RUDDER	PLUMES	REFERENCE	AREA	UNIT
(DBJ501)	AMES 97-616 1A2 01 TO S1 NO PLUMES	.000	.000	.000	.000	SREF	3155.0000	SQ.FT.
(DBJ511)	AMES 97-616 1A2 01 TO S1 NO PLUMES	10.000	.000	10.000	.000	LREF	50.8000	FT.
(RBJ003)	AMES 97-616 1A2 01 TO S1 PC/PT NOM, SRM A/A=8	.000	.000	.000	2.000	BREF	73.5000	FT.
(RBJ013)	AMES 97-616 1A2 01 TO S1 PC/PT NOM, SRM A/A=8	10.000	.000	10.000	2.000	XMRP	86.4167	FT.
(DBJ005)	AMES 97-616 1A2 01 TO S1 PC/PT NOM	.000	.000	.000	3.000	YMRP	.0000	FT.
(DBJ015)	AMES 97-616 1A2 01 TO S1 PC/PT NOM	10.000	.000	10.000	3.000	ZMRP	4.0000	FT.
						SCALE	.0190	

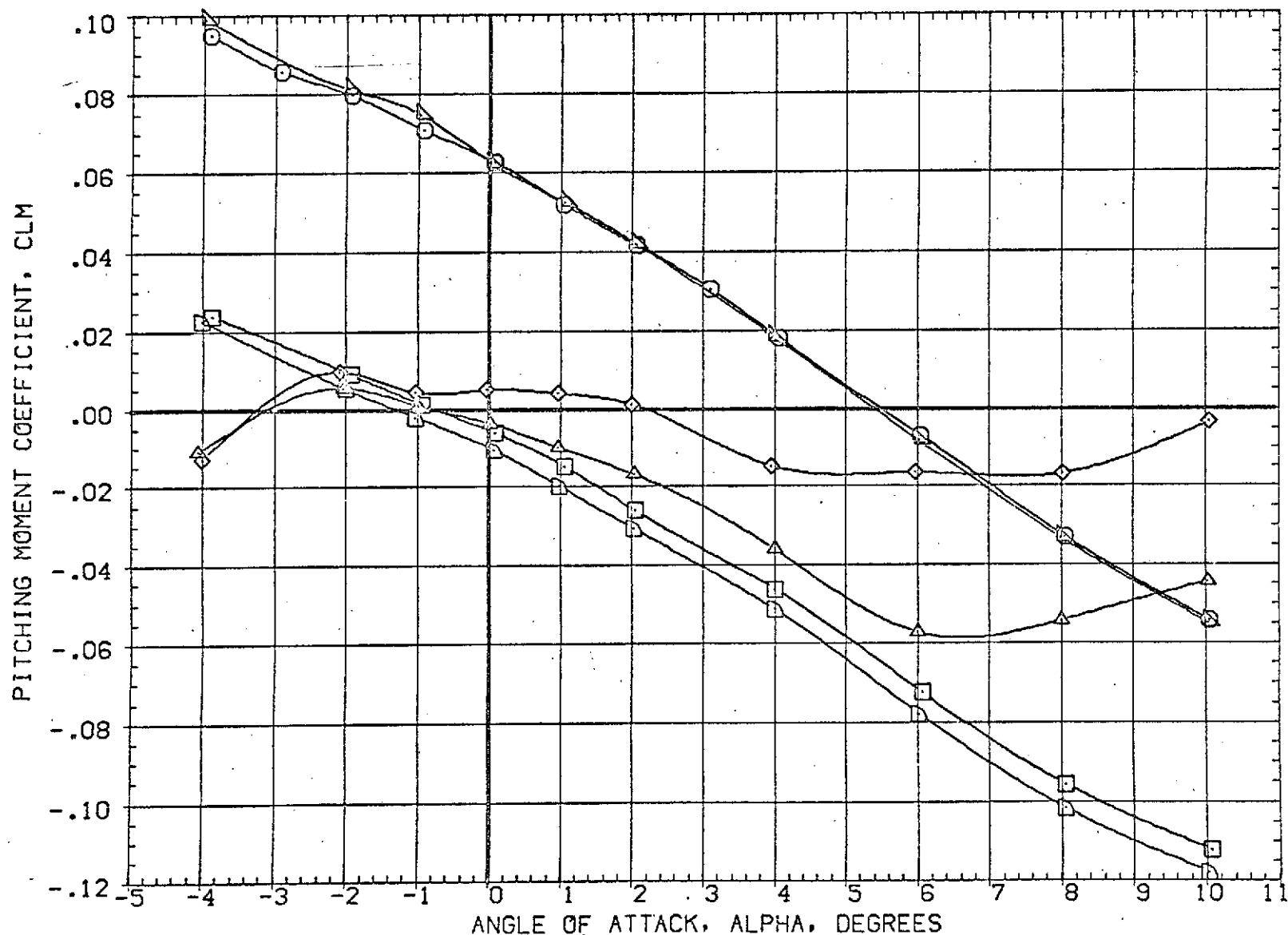

FIG 23 EFFECT OF ORBITER AND SRM PLUMES ON ELEVON AND RUDDER POWER, BETA=0.0

(A) MACH = 1.60

(CBJ001)	AMES 97-616	1A2 01	TO S1	NO PLUMES	.000	.000	.000	.000	SREF	3155.0000	50.000	FT.
(CBJ011)	AMES 97-616	1A2 01	TO S1	NO PLUMES	10.000	.000	10.000	.000	LREF	50.8000	73.5000	FT.
(RBJ003)	AMES 97-616	1A2 01	TO S1	PC/PT NOM, SRM A/A-8	.000	.000	.000	2.000	BREF	73.5000	86.4157	FT.
(RBJ013)	AMES 97-616	1A2 01	TO S1	PC/PT NOM, SRM A/A-8	10.000	.000	10.000	2.000	XMRP	86.4157	.0000	FT.
(CBJ005)	AMES 97-616	1A2 01	TO S1	PC/PT NOM	.000	.000	.000	3.000	YMRP	.0000	4.0000	FT.
(CBJ015)	AMES 97-616	1A2 01	TO S1	PC/PT NOM	10.000	.000	10.000	3.000	ZMRP	4.0000	.0190	FT.

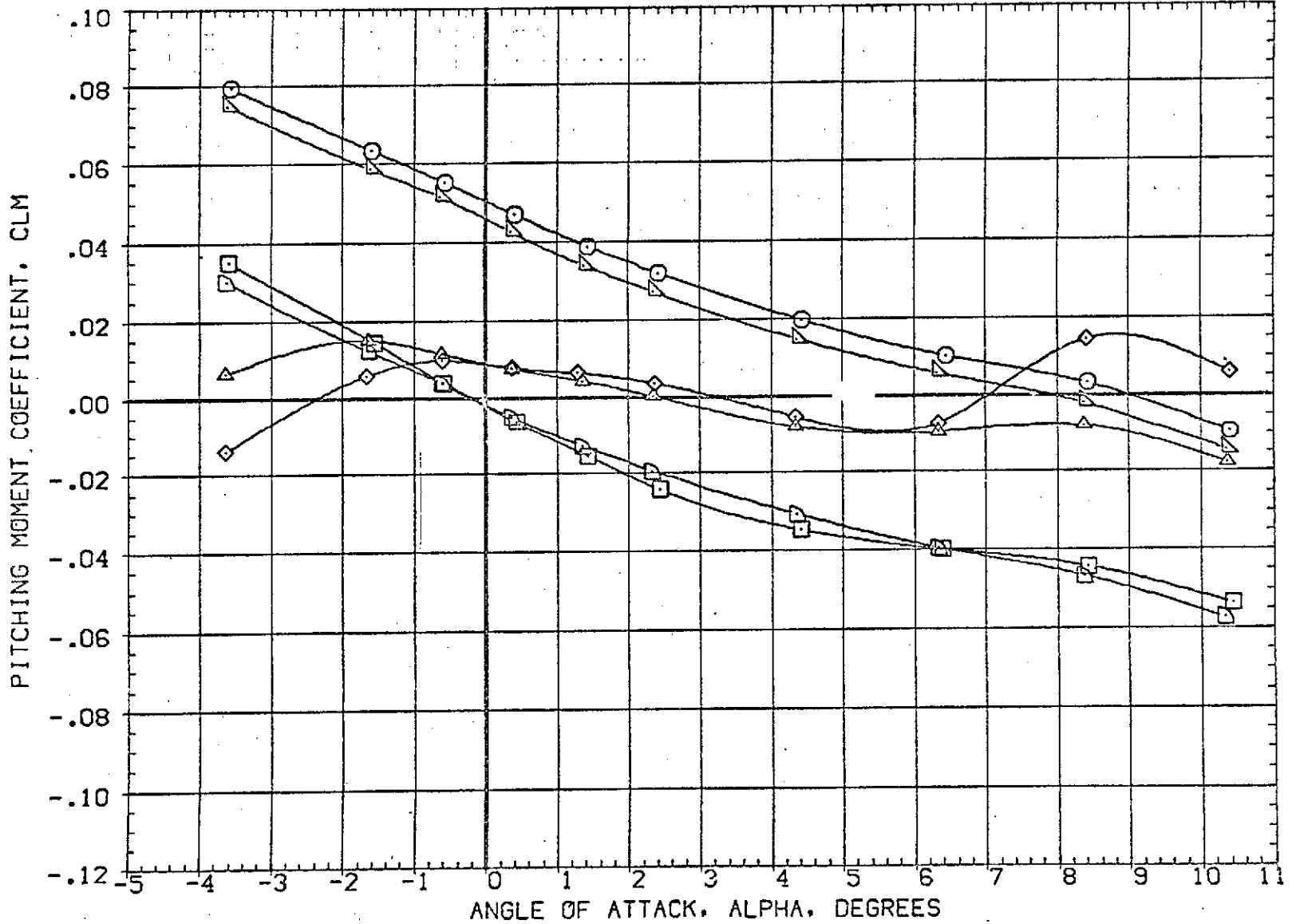

FIG 23 EFFECT OF ORBITER AND SRM PLUMES ON ELEVON AND RUDDER POWER, BETA=0.0

(B)MACH = 1.98

DATA SET SYMBOL	CONFIGURATION DESCRIPTION	ELEVON	AILRON	RUDDER	PLUMES	REFERENCE INFORMATION
(DBJ501)	AMES 97-616 1A2 01 TO S1 NO PLUMES	.000	.000	.000	.000	SREF 3155.0000 SQ.FT.
(DBJ511)	AMES 97-616 1A2 01 TO S1 NO PLUMES	10.000	.000	10.000	.000	LREF 50.8000 FT.
(R3J003)	AMES 97-616 1A2 01 TO S1 PC/PT NOM. SRM A/A-8	.000	.000	.000	2.000	BREF 73.5000 FT.
(R3J013)	AMES 97-616 1A2 01 TO S1 PC/PT NOM. SRM A/A-8	10.000	.000	10.000	2.000	XMRP 86.4167 FT.
(D9J005)	AMES 97-616 1A2 01 TO S1 PC/PT NOM	.000	.000	.000	3.000	YMRP .0000 FT.
(DBJ015)	AMES 97-616 1A2 01 TO S1 PC/PT NOM	10.000	.000	10.000	3.000	ZMRP 4.0000 FT.
						SCALE .0190

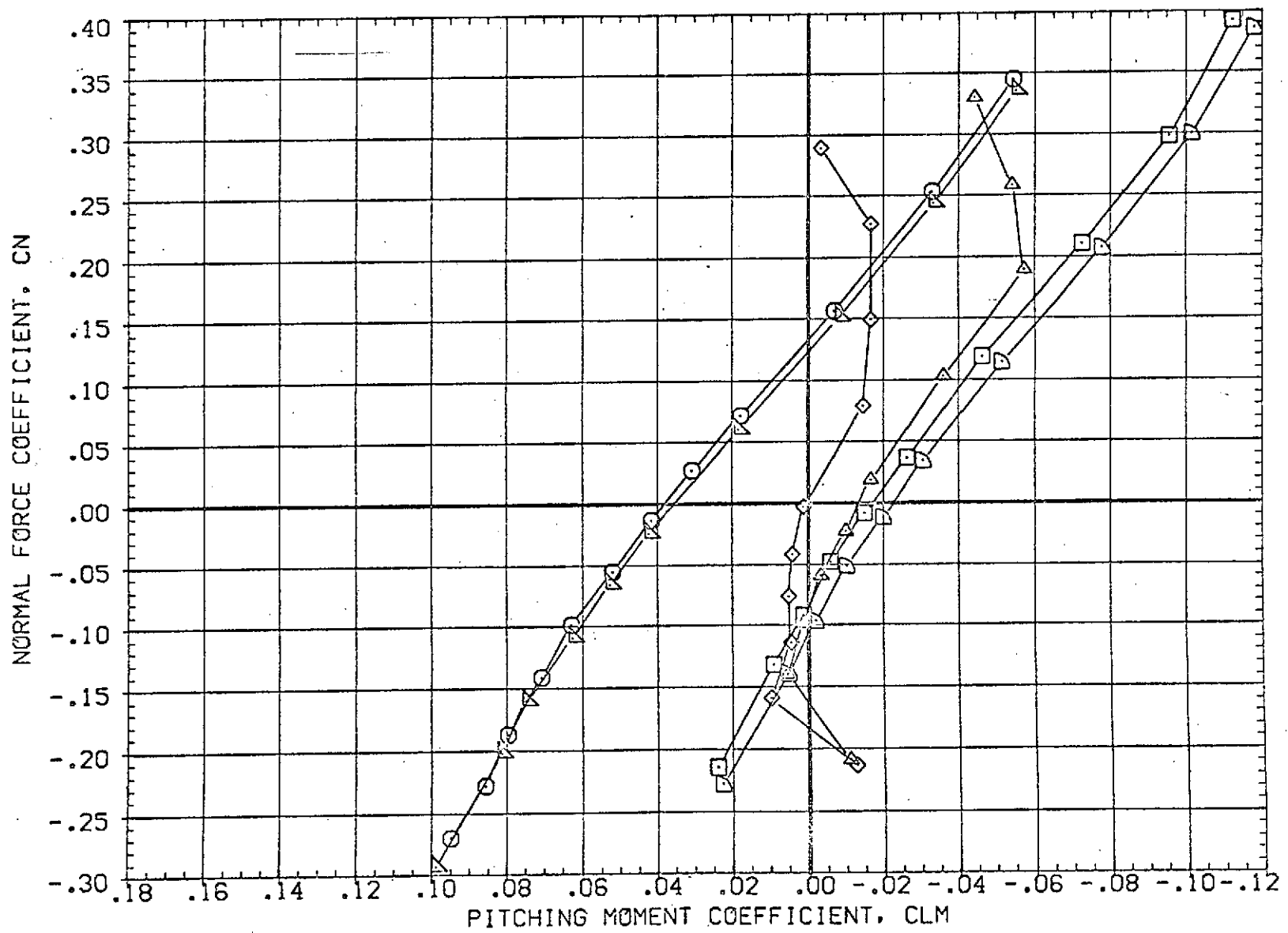

FIG 23 EFFECT OF ORBITER AND SRM PLUMES ON ELEVON AND RUDDER POWER, BETA=0.0

(A)MACH = 1.60

DATA SET SYMBOL	CONFIGURATION DESCRIPTION	ELEVON	AILEON	RUDDER	PLUMES	REFERENCE CONFIGURATION	SD.FT.
(CBJ501)	AMES 97-616 IA2 01 TO S1 NO PLUMES	.000	.000	.000	.000	SREF	3155.0000
(CBJ511)	AMES 97-616 IA2 01 TO S1 NO PLUMES	10.000	.000	10.000	.000	LREF	50.8000
(RBJ003)	AMES 97-616 IA2 01 TO S1 PC/PT NOM. SRM A/A=8	.000	.000	.000	2.000	BREF	73.5000
(RBJ013)	AMES 97-616 IA2 01 TO S1 PC/PT NOM. SRM A/A=8	10.000	.000	10.000	2.000	XMRP	86.4167
(CBJ005)	AMES 97-616 IA2 01 TO S1 PC/PT NOM	.000	.000	.000	3.000	YMRP	.0000
(CBJ015)	AMES 97-616 IA2 01 TO S1 PC/PT NOM	10.000	.000	10.000	3.000	ZMRP	4.0000
						SCALE	.0190

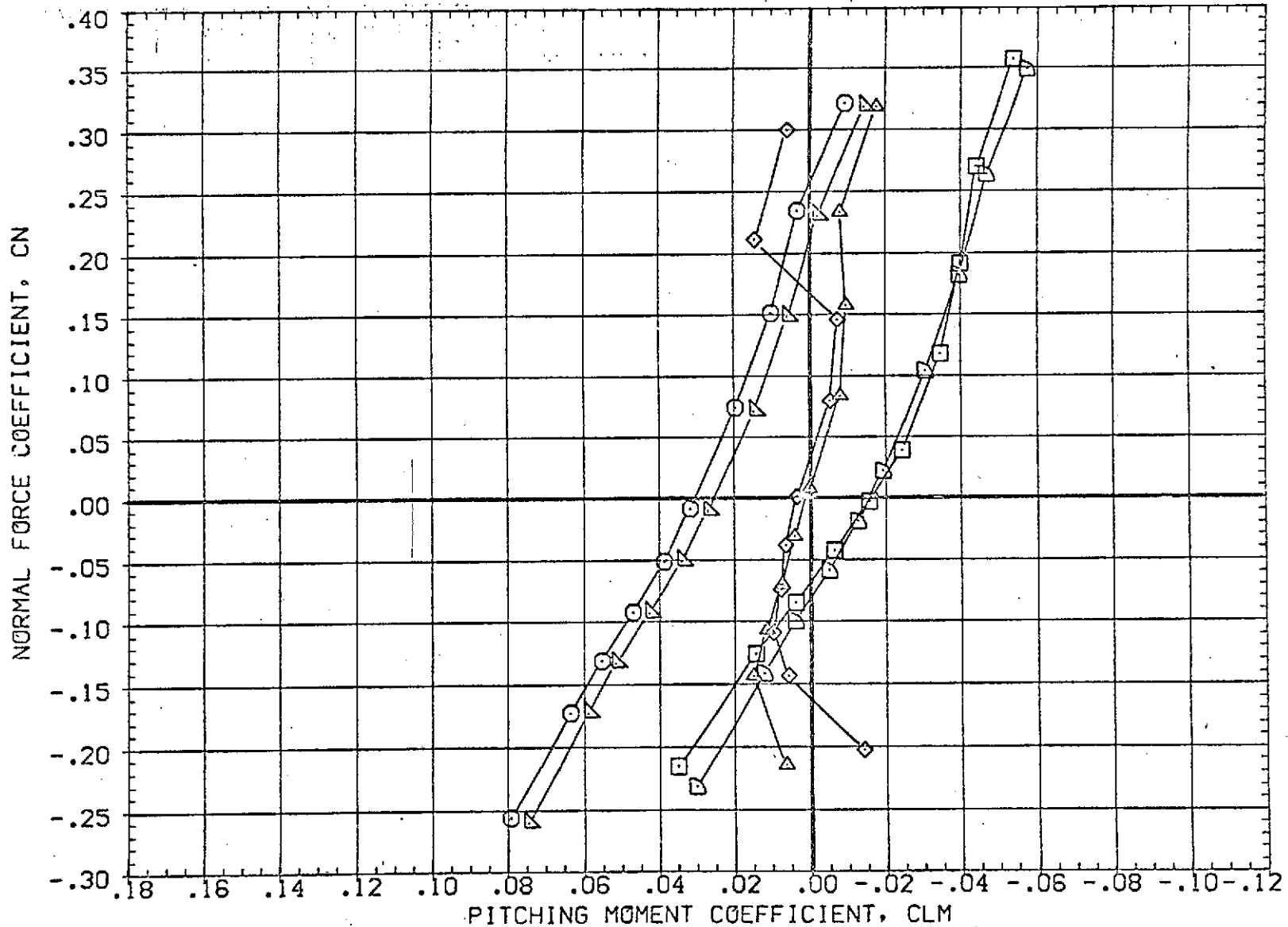

FIG 23 EFFECT OF ORBITER AND SRM PLUMES ON ELEVON AND RUDDER POWER, BETA=0.0

(8)MACH = 1.98

DATA SET SYMBOL	CONFIGURATION DESCRIPTION	ELEVON	AILRON	RUDDER	PLUMES	REFERENCE INFORMATION
(DBJ501)	AMES 97-616 1A2 01 TO S1 NO PLUMES	.000	.000	.000	.000	SREF 3155.0000 SQ.FT.
(DBJ511)	AMES 97-616 1A2 01 TO S1 NO PLUMES	10.000	.000	10.000	.000	LREF 50.8000 FT.
(RBJ003)	AMES 97-616 1A2 01 TO S1 PC/PT NOM. SRM A/A=8	.000	.000	.000	2.000	BREF 73.5000 FT.
(RBJ013)	AMES 97-616 1A2 01 TO S1 PC/PT NOM. SRM A/A=8	10.000	.000	10.000	2.000	XMRP 86.4167 FT.
(DBJ005)	AMES 97-616 1A2 01 TO S1 PC/PT NOM	.000	.000	.000	3.000	YMRP .0000 FT.
(DBJ015)	AMES 97-616 1A2 01 TO S1 PC/PT NOM	10.000	.000	10.000	3.000	ZMRP 4.0000 FT.
						SCALE .0190

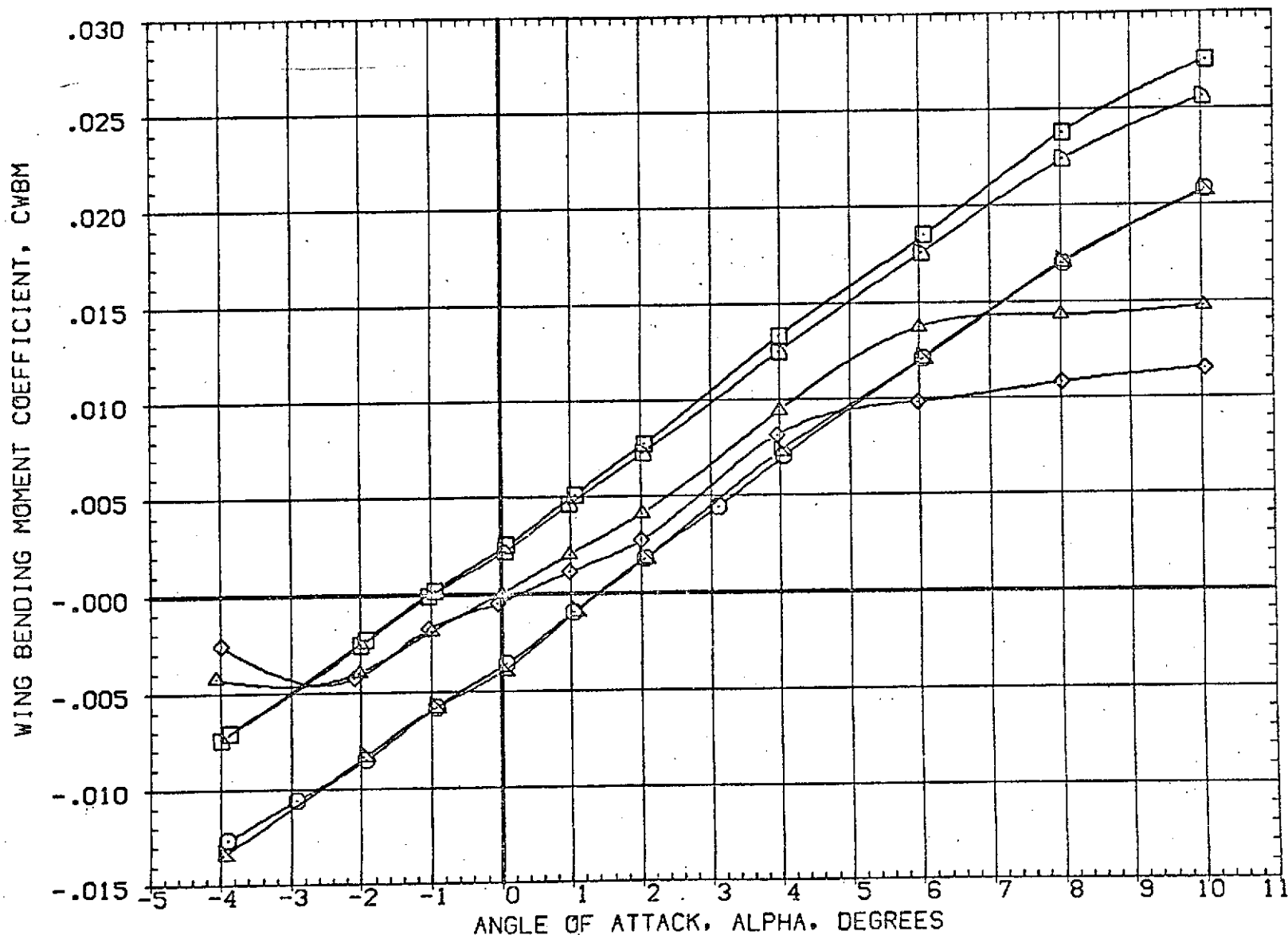

FIG 23 EFFECT OF ORBITER AND SRM PLUMES ON ELEVON AND RUDDER POWER, BETA=0.0

(A) MACH = 1.60

DATA SET SYMBOL	CONFIGURATION DESCRIPTION	ELEVON	AILERON	RUDDER	PLUMES	SCALE	ORBITER	SRM	PLUMES	SCALE	ORBITER	SRM	PLUMES
(DBJ501)	AMES 97-616 1A2 01 TO S1 NO PLUMES	.000	.000	.000	.000	SREF	3155.0000	SO.FT.					
(DBJ511)	AMES 97-616 1A2 01 TO S1 NO PLUMES	10.000	.000	10.000	.000	LREF	50.8000	FT.					
(RBJ003)	AMES 97-616 1A2 01 TO S1 PC/PT-NOM.SRM A/A-8	.000	.000	.000	2.000	BREF	73.5000	FT.					
(RBJ013)	AMES 97-616 1A2 01 TO S1 PC/PT-NOM.SRM A/A-8	10.000	.000	10.000	2.000	XMRP	86.4167	FT.					
(DBJ005)	AMES 97-616 1A2 01 TO S1 PC/PT-NOM	.000	.000	.000	3.000	YMRP	.0000	FT.					
(DBJ015)	AMES 97-616 1A2 01 TO S1 PC/PT-NOM	10.000	.000	10.000	3.000	ZMRP	4.0000	FT.					
						SCALE	.0190						

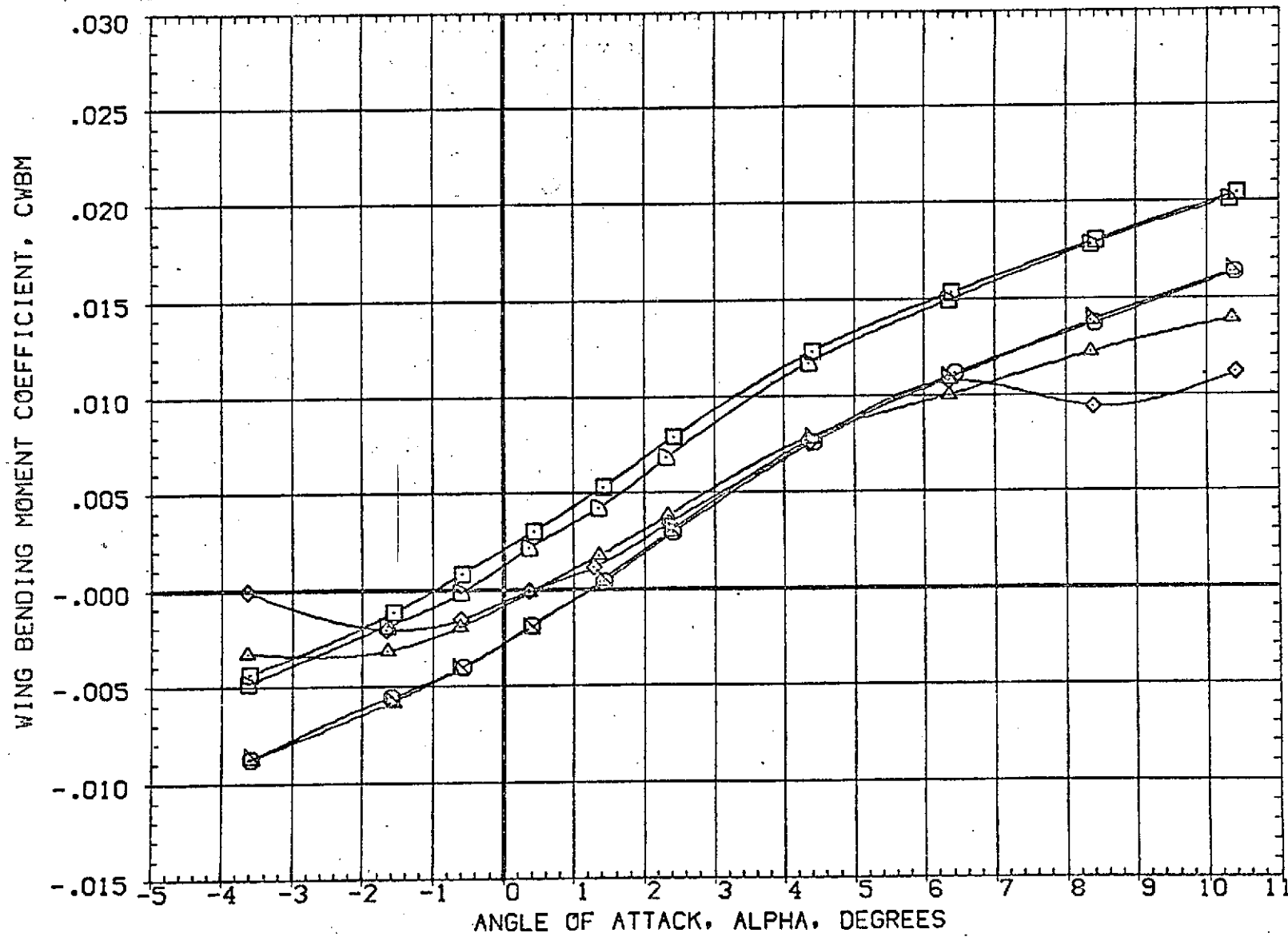

FIG 23 EFFECT OF ORBITER AND SRM PLUMES ON ELEVON AND RUDDER POWER, BETA=0.0

(B)MACH = 1.98

DATA SET SYMBOL	CONFIGURATION DESCRIPTION	ELEVON	AILERON	RUDDER	PLUMES	REFERENCE INFORMATION		
(DBJ501)	AMES 97-616 IA2 01 TO S1 NO PLUMES	.000	.000	.000	.000	SREF	3155.0000	SQ.FT.
(DBJ511)	AMES 97-616 IA2 01 TO S1 NO PLUMES	10.000	.000	10.000	.000	LREF	50.8000	FT.
(RBJ003)	AMES 97-616 IA2 01 TO S1 PC/PT NCM, SRM A/A=8	.000	.000	.000	2.000	BREF	73.5000	FT.
(RBJ013)	AMES 97-616 IA2 01 TO S1 PC/PT NCM, SRM A/A=8	10.000	.000	10.000	2.000	XMRP	86.4167	FT.
(DBJ005)	AMES 97-616 IA2 01 TO S1 PC/PT NCM	.000	.000	.000	3.000	YMRP	.0000	FT.
(DBJ015)	AMES 97-616 IA2 01 TO S1 PC/PT NCM	10.000	.000	10.000	3.000	ZMRP	4.0000	FT.
						SCALE	.0150	

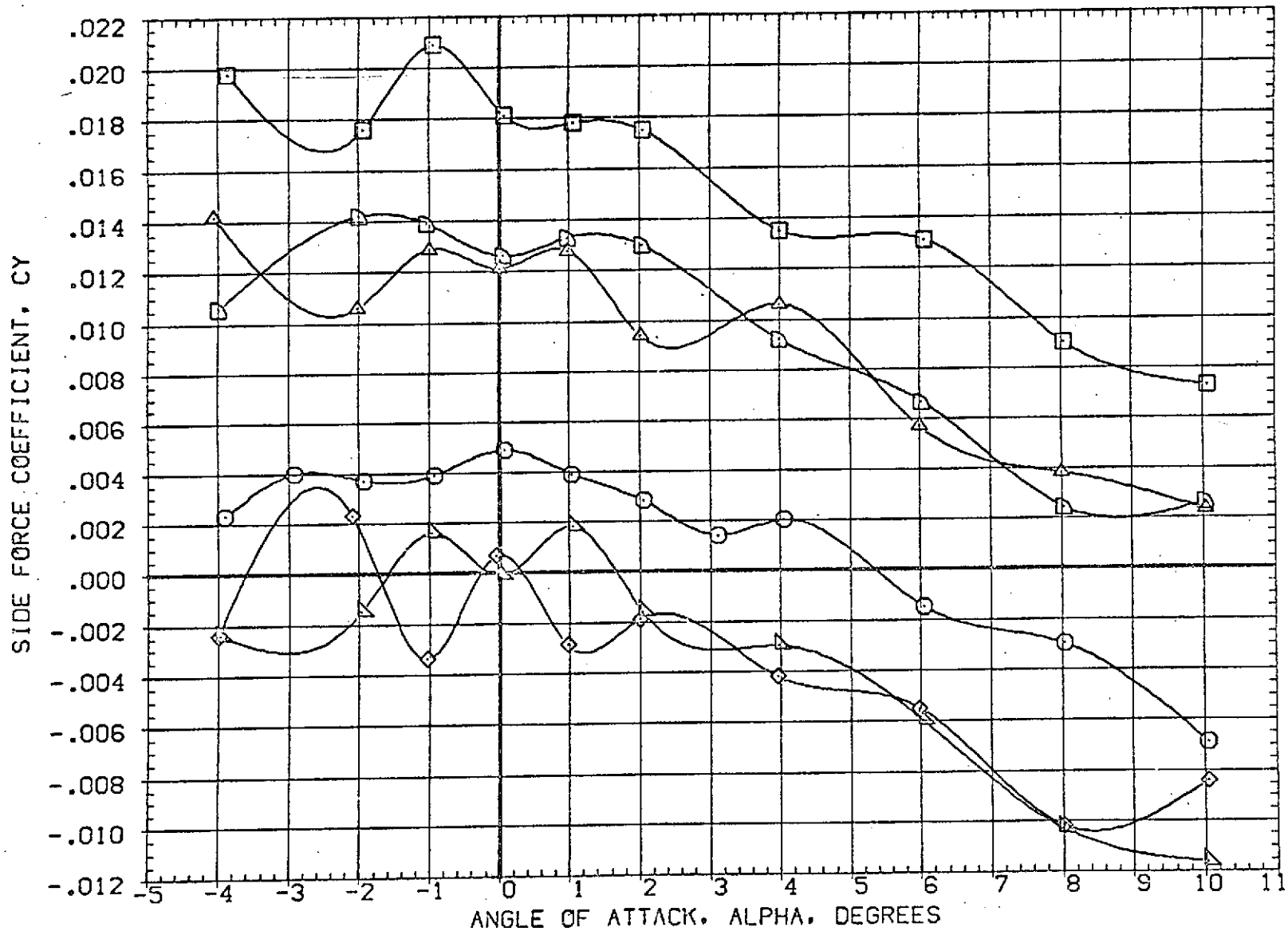

FIG 23 EFFECT OF ORBITER AND SRM PLUMES ON ELEVON AND RUDDER POWER, BETA=0.0

(A) MACH = 1.60

DATA SET SYMBOL	CONFIGURATION DESCRIPTION	ELEVON	AILRON	RUDDER	PLUMES	REFERENCE INFORMATION
(000501)	AM 97-016 IA2 01 TO S1 NO PLUMES	.000	.000	.000	.000	SREF 3155.0000 SQ.FT.
(000511)	AM 97-016 IA2 01 TO S1 NO PLUMES	10.000	.000	10.000	.000	LREF 50.8000 FT.
(000503)	AM 97-016 IA2 01 TO S1 PC/PT NOM SRM A/A-8	.000	.000	.000	2.000	BREF 73.5000 FT.
(000513)	AM 97-016 IA2 01 TO S1 PC/PT NOM SRM A/A-8	10.000	.000	10.000	2.000	XMRP 86.4167 FT.
(000505)	AM 97-016 IA2 01 TO S1 PC/PT NOM	.000	.000	.000	3.000	YMRP .0000 FT.
(000515)	AM 97-016 IA2 01 TO S1 PC/PT NOM	10.000	.000	10.000	3.000	ZMRP 4.0000 FT.
						SCALE .0190

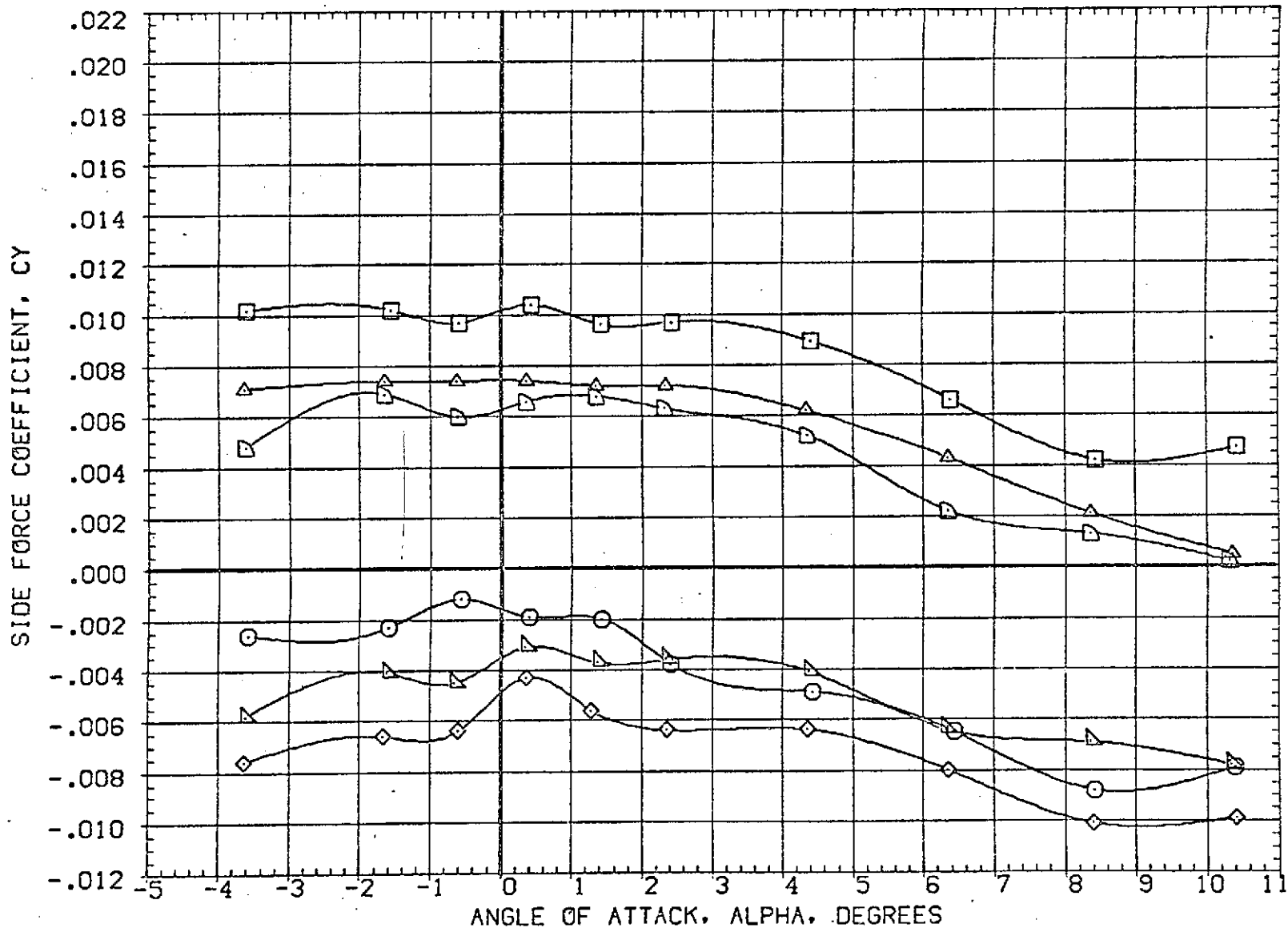

FIG 23 EFFECT OF ORBITER AND SRM PLUMES ON ELEVON AND RUDDER POWER, BETA=0.0

(B)MACH = 1.98

DATA SET SYMBOL	CONFIGURATION DESCRIPTION	ELEVON	AILERON	RUDDER	PLUMES	REFERENCE INFORMATION
(DBJ501)	AMES 97-616 1A2 01 TO S1 NO PLUMES	.000	.000	.000	.000	SREF 3155.0000 SQ.FT.
(DBJ511)	AMES 97-616 1A2 01 TO S1 NO PLUMES	10.000	.000	10.000	.000	LREF 50.8000 FT.
(RBJ003)	AMES 97-616 1A2 01 TO S1 PC/PT NOM. SRM A/A-8	.000	.000	.000	2.000	BREF 73.5000 FT.
(RBJ013)	AMES 97-616 1A2 01 TO S1 PC/PT NOM. SRM A/A-8	10.000	.000	10.000	2.000	XMRP 86.4167 FT.
(DBJ005)	AMES 97-616 1A2 01 TO S1 PC/PT NOM	.000	.000	.000	3.000	YMRP .0000 FT.
(DBJ015)	AMES 97-616 1A2 01 TO S1 PC/PT NOM	10.000	.000	10.000	3.000	ZMRP 4.0000 FT.
						SCALE .0190

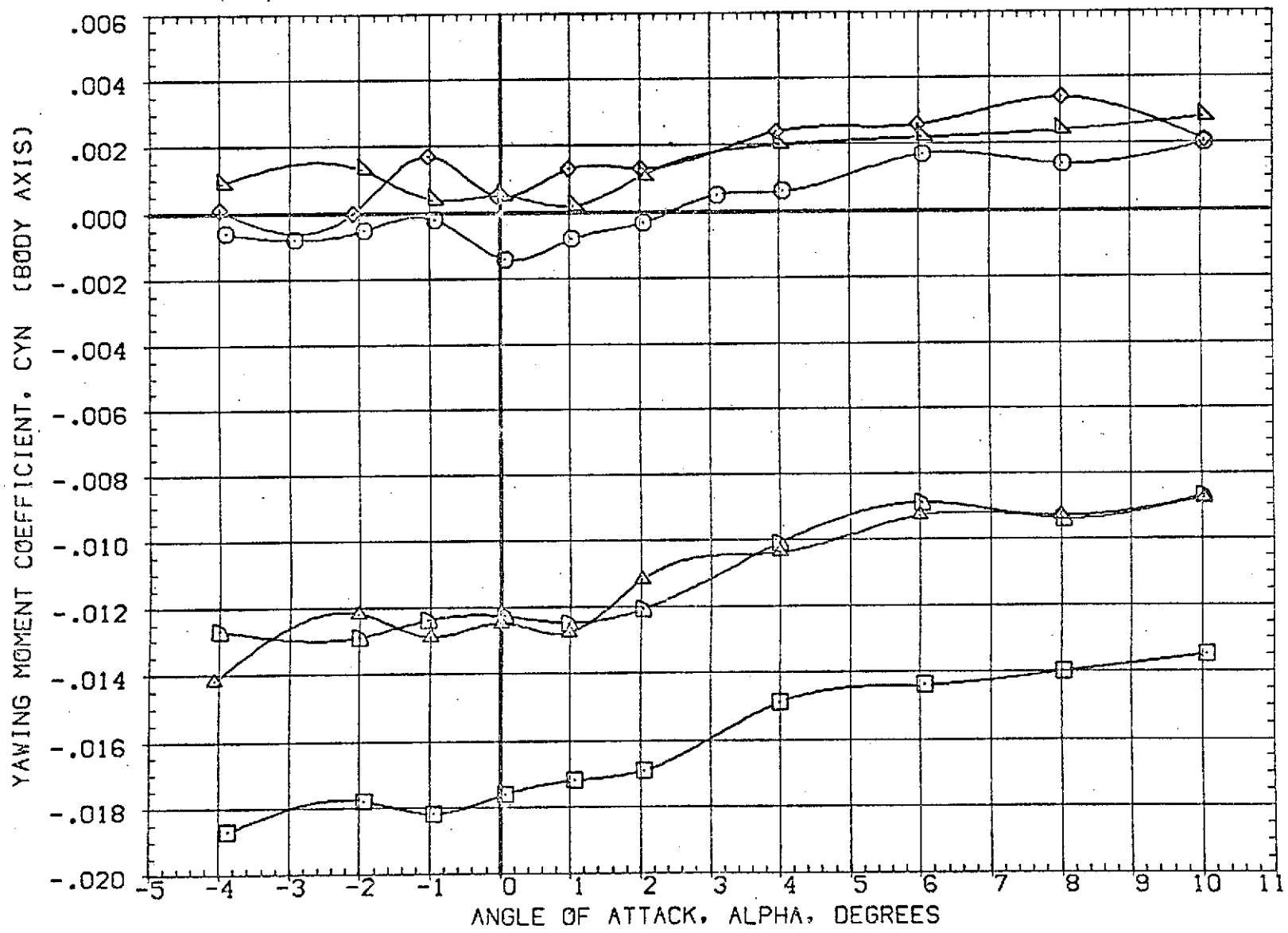

FIG 23 EFFECT OF ORBITER AND SRM PLUMES ON ELEVON AND RUDDER POWER, BETA=0.0
 (A)MACH = 1.60 PAGE 189

DATA SET SYMBOL	CONFIGURATION DESCRIPTION	ELEVON	AIRLON	RUDDER	PLUMES	REFERENCE INFORMATION	
(DBJ501)	AMES 97-616 1A2 01 TO S1 NO PLUMES	.000	.000	.000	.000	SREF	3155.0000 SQ.FT.
(DBJ511)	AMES 97-616 1A2 01 TO S1 NO PLUMES	10.000	.000	10.000	.000	LREF	50.8000 FT.
(RBJ003)	AMES 97-616 1A2 01 TO S1 PC/PT NOM. SRM A/A=8	.000	.000	.000	2.000	BREF	73.5000 FT.
(RBJ013)	AMES 97-616 1A2 01 TO S1 PC/PT NOM. SRM A/A=8	10.000	.000	10.000	2.000	XMRP	86.4167 FT.
(DBJ005)	AMES 97-616 1A2 01 TO S1 PC/PT NOM	.000	.000	.000	3.000	YMRP	.0000 FT.
(DBJ015)	AMES 97-616 1A2 01 TO S1 PC/PT NOM	10.000	.000	10.000	3.000	ZMRP	4.0000 FT.
						SCALE	.0190

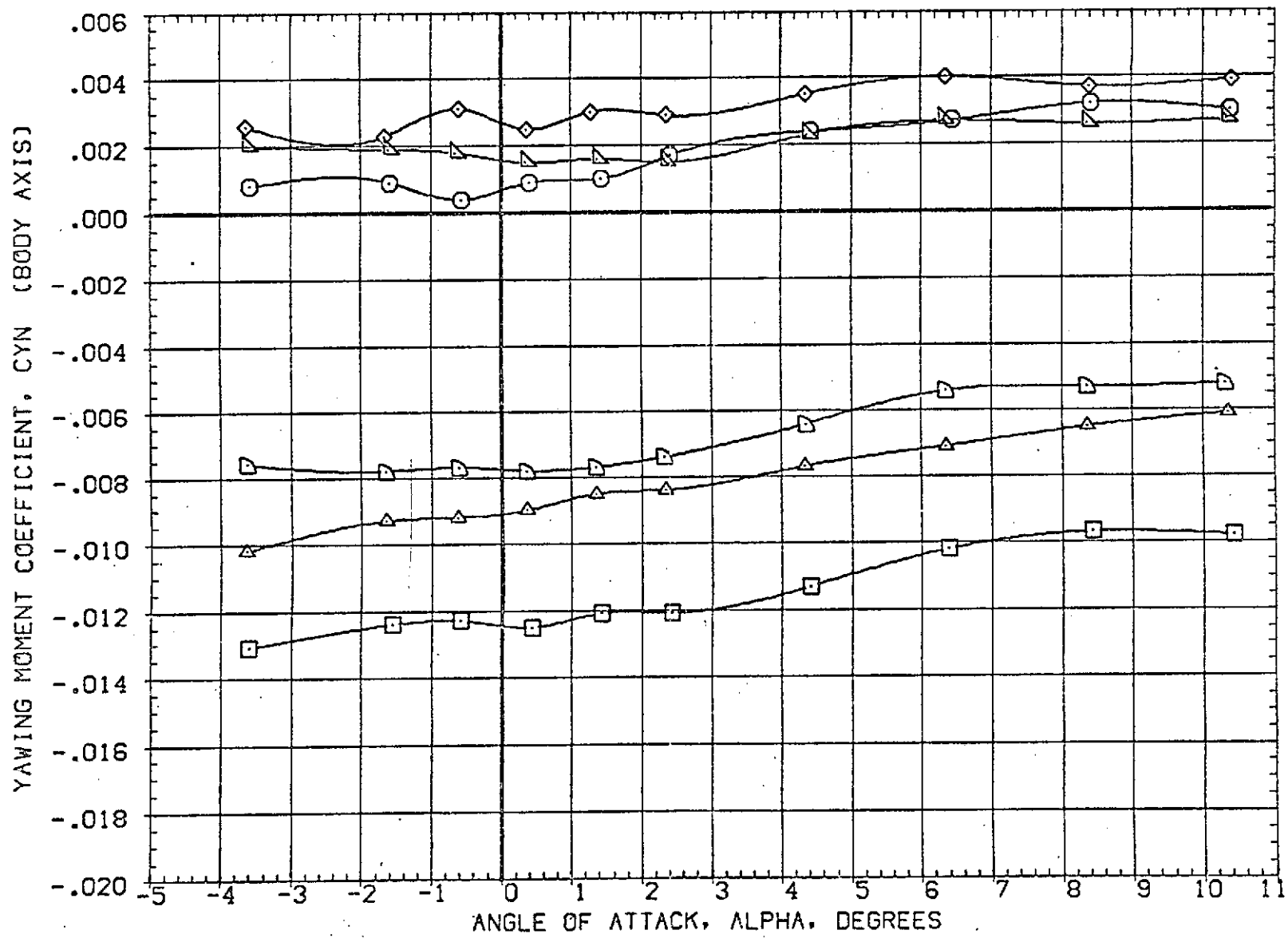

FIG 23 EFFECT OF ORBITER AND SRM PLUMES ON ELEVON AND RUDDER POWER, BETA=0.0

(B)MACH = 1.98

DATA SET SYMBOL	CONFIGURATION DESCRIPTION	ELEVON	AILRON	RUDDER	PLUMES	REFERENCE INFORMATION
(DBJ501)	AMES 97-616 IA2 01 TO S1 NO PLUMES	.000	.000	.000	.000	SREF 3155.0000 SQ.FT.
(DBJ511)	AMES 97-616 IA2 01 TO S1 NO PLUMES	10.000	.000	10.000	.000	LREF 50.8000 FT.
(RBJ003)	AMES 97-616 IA2 01 TO S1 PC/PT NOM, SRM A/A-8	.000	.000	.000	2.000	BREF 73.5000 FT.
(RBJ013)	AMES 97-616 IA2 01 TO S1 PC/PT NOM, SRM A/A-8	10.000	.000	10.000	2.000	XMRP 86.4167 FT.
(DBJ005)	AMES 97-616 IA2 01 TO S1 PC/PT NOM	.000	.000	.000	3.000	YMRP .0000 FT.
(DBJ015)	AMES 97-616 IA2 01 TO S1 PC/PT NOM	10.000	.000	10.000	3.000	ZMRP 4.0000 FT.
						SCALE .0190

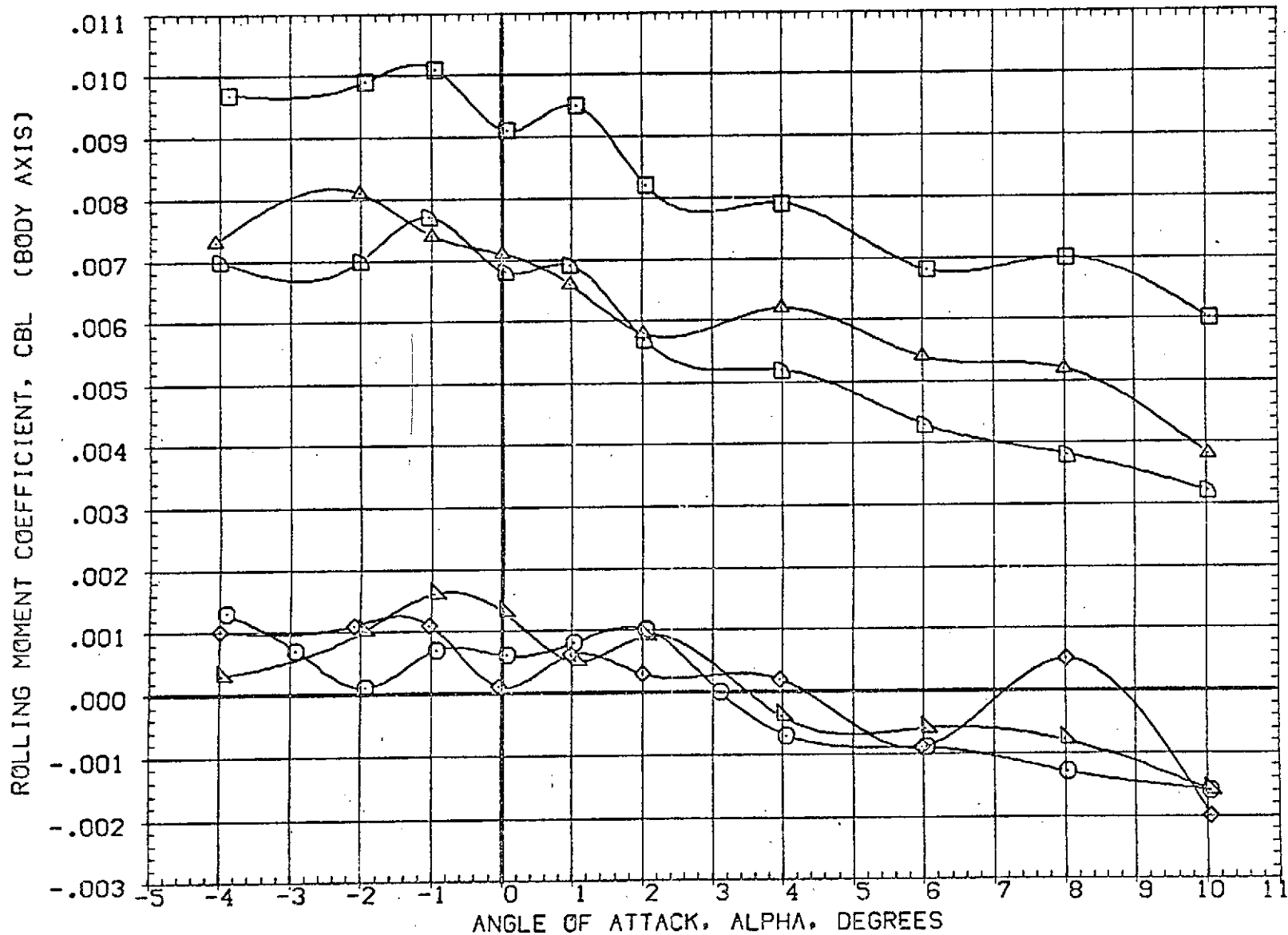

FIG 23 EFFECT OF ORBITER AND SRM PLUMES ON ELEVON AND RUDDER POWER, BETA=0.0

(A)MACH = 1.60

DATA SET SYMBOL	CONFIGURATION DESCRIPTION	ELEVON	AILRON	RUDDER	PLUMES	REFERENCE INFORMATION
(DBJ501)	AMES 97-616 1A2 01 TO S1 NO PLUMES	.000	.000	.000	.000	SREF 3155.0000 SQ.FT.
(DBJ511)	AMES 97-616 1A2 01 TO S1 NO PLUMES	10.000	.000	10.000	.000	LREF 50.8000 FT.
(RBJ003)	AMES 97-616 1A2 01 TO S1 PC/PT NOM, SRM A/A=8	.000	.000	.000	2.000	BREF 73.5000 FT.
(RBJ013)	AMES 97-616 1A2 01 TO S1 PC/PT NOM, SRM A/A=8	10.000	.000	10.000	2.000	XMRP 86.4167 FT.
(DBJ005)	AMES 97-616 1A2 01 TO S1 PC/PT NOM	.000	.000	.000	3.000	YMRP .0000 FT.
(DBJ015)	AMES 97-616 1A2 01 TO S1 PC/PT NOM	10.000	.000	10.000	3.000	ZMRP 4.0000 FT.
						SCALE .0190

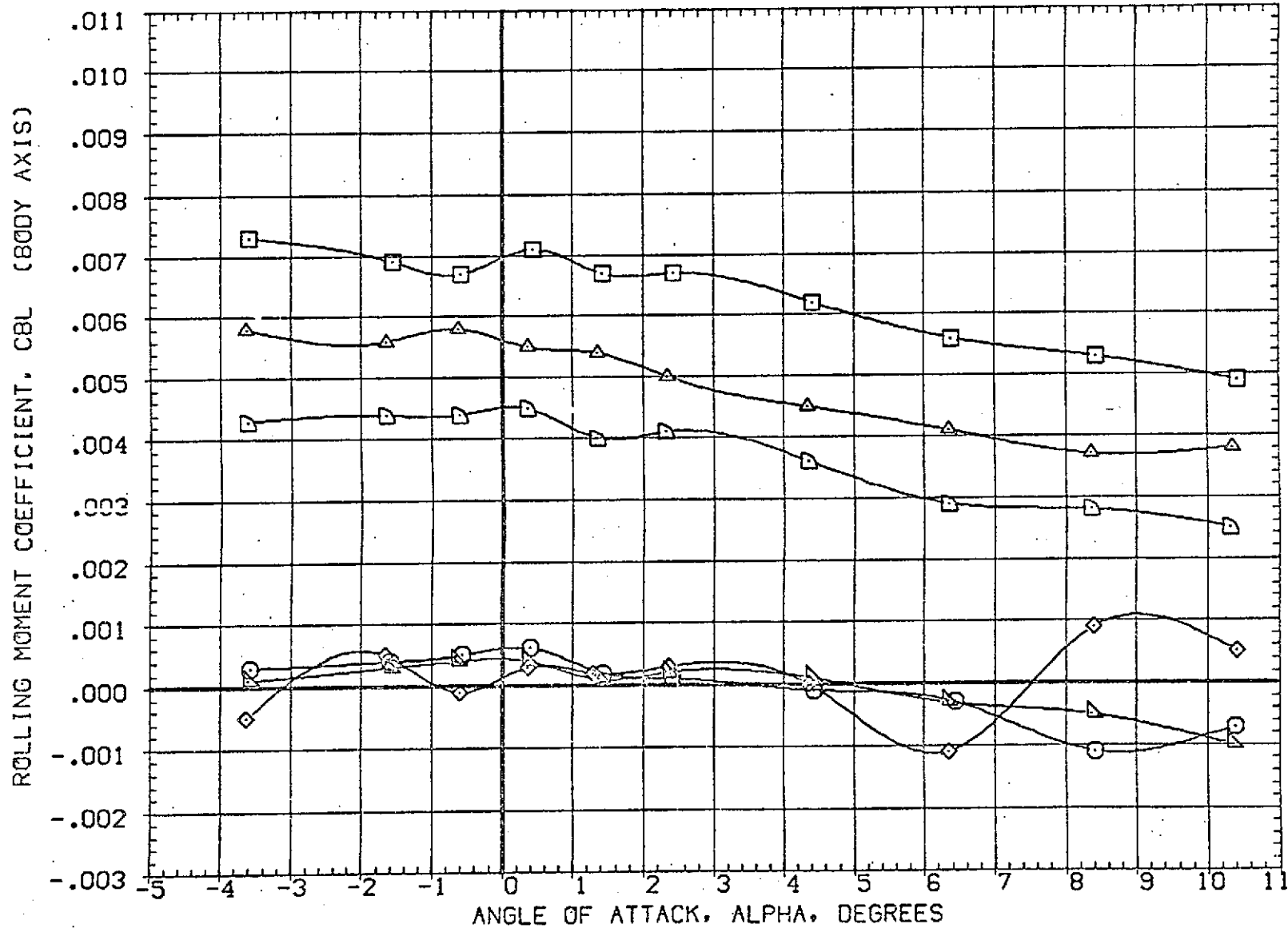

FIG 23 EFFECT OF ORBITER AND SRM PLUMES ON ELEVON AND RUDDER POWER, BETA=0.0

(B)MACH = 1.98

DATA SET SYMBOL	CONFIGURATION DESCRIPTION	ELEVON	AILRON	RUDDER	PLUMES	REFERENCE INFORMATION
(DBJ502)	AMES 97-616 1A2 01 TO S1 NO PLUMES	.000	.000	.000	.000	SREF 3155.0000 SQ.FT.
(DBJ512)	AMES 97-616 1A2 01 TO S1 NO PLUMES	10.000	.000	10.000	.000	LREF 50.9000 FT.
(DBJ004)	AMES 97-616 1A2 01 TO S1 PC/PT NOM. SRM A/A-8	.000	.000	.000	2.000	BREF 73.5000 FT.
(DBJ014)	AMES 97-616 1A2 01 TO S1 PC/PT-NOM. SRM A/A-8	10.000	.000	10.000	2.000	XMRP 86.4167 FT.
(DBJ006)	AMES 97-616 1A2 01 TO S1 PC/PT NOM	.000	.000	.000	3.000	YMRP .0000 FT.
(DBJ016)	AMES 97-616 1A2 01 TO S1 PC/PT NOM	10.000	.000	10.000	3.000	ZMRP 4.0000 FT.
						SCALE .0190

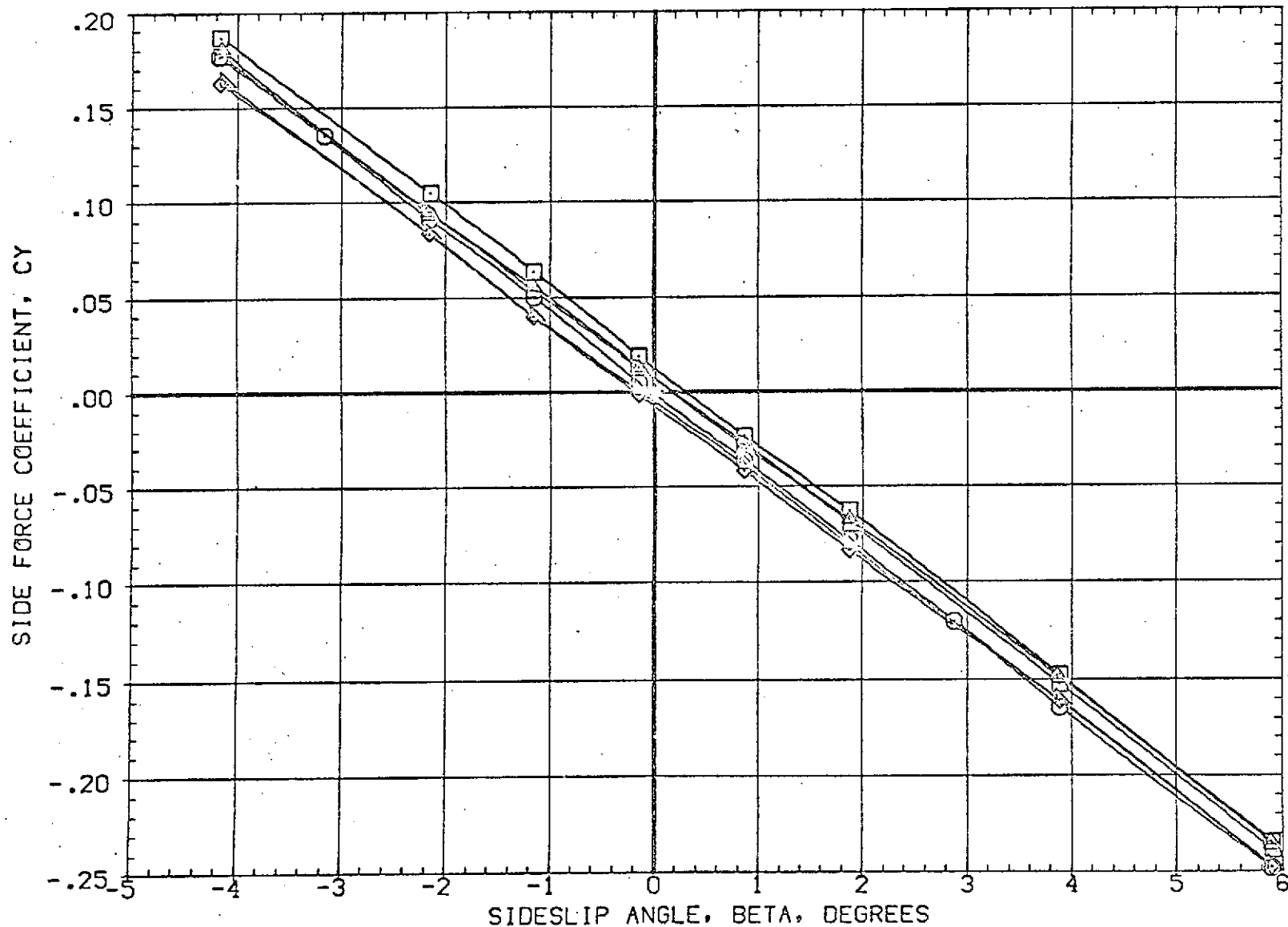

FIG 24 EFFECT OF ORBITER AND SRM PLUMES ON ELEVON AND RUDDER POWER, ALPHA=0.0
 (A)MACH = 1.60

DATA SET SYMBOL	CONFIGURATION DESCRIPTION	ELEVON	AIRLON	RUDDER	PLUMES	REFERENCE INFORMATION
(DBJ502)	AMES 97-616 1A2 01 TO S1 NO PLUMES	.000	.000	.000	.000	SREF 3155.0000 SQ.FT.
(DBJ512)	AMES 97-616 1A2 01 TO S1 NO PLUMES	10.000	.000	10.000	.000	LREF 50.8000 FT.
(RBJ004)	AMES 97-616 1A2 01 TO S1 PC/PT NGM, SRM A/A=8	.000	.000	.000	2.000	BREF 73.5000 FT.
(RBJ014)	AMES 97-616 1A2 01 TO S1 PC/PT=NGM, SRM A/A=8	10.000	.000	10.000	2.000	XM RP 86.4167 FT.
(DBJ006)	AMES 97-616 1A2 01 TO S1 PC/PT NGM	.000	.000	.000	3.000	YM RP .0000 FT.
(DBJ016)	AMES 97-616 1A2 01 TO S1 PC/PT NGM	10.000	.000	10.000	3.000	ZM RP 4.0000 FT.
						SCALE .0190

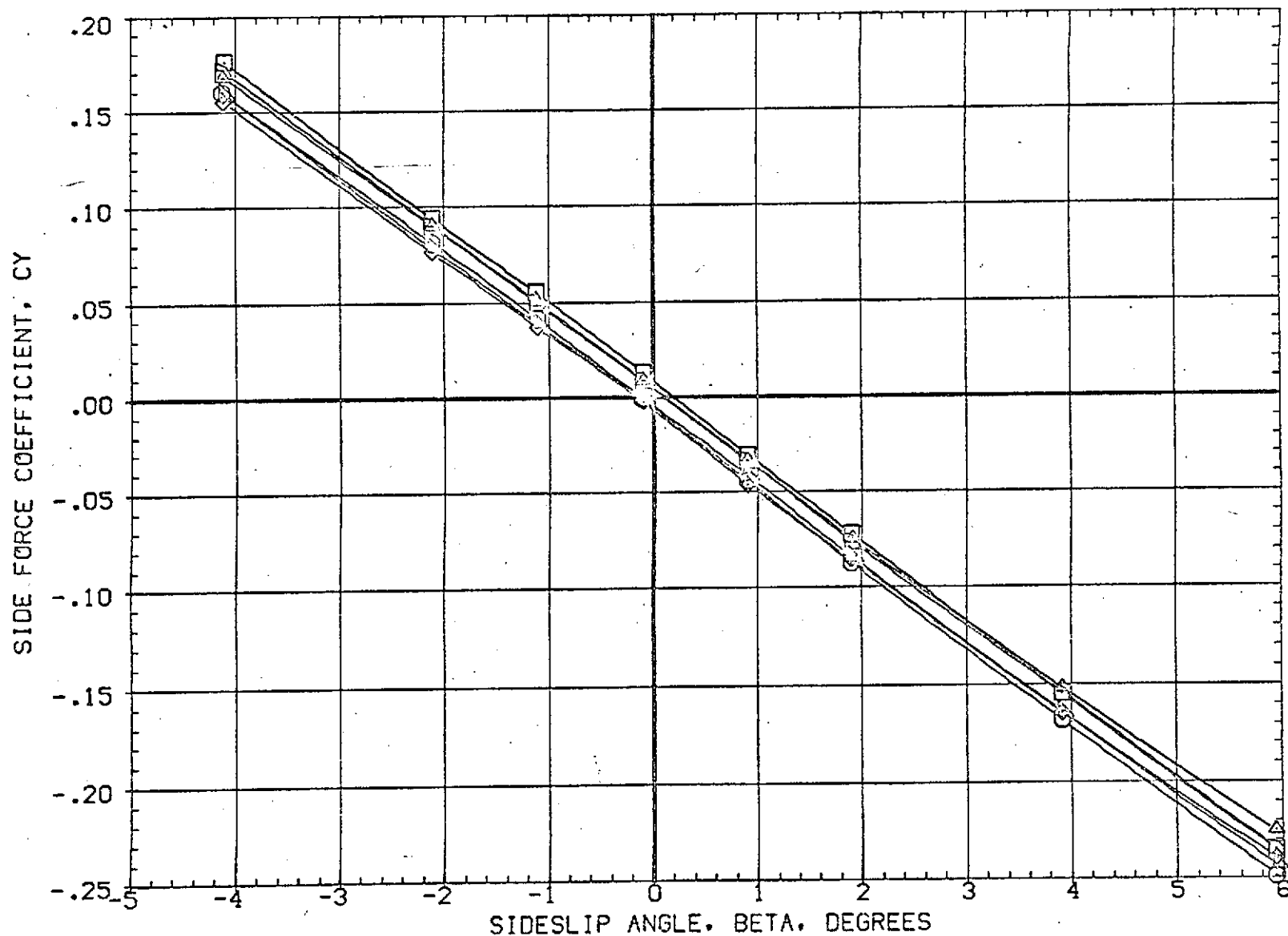

FIG 24 EFFECT OF ORBITER AND SRM PLUMES ON ELEVON AND RUDDER POWER, ALPHA=0.0

(B)MACH = 1.98

DATA SET	SYMBOL	CONFIGURATION DESCRIPTION	ELEVON	AILRON	RUDDER	PLUMES	REFERENCE INFORMATION
(OBJ502)	○	AMES 97-616 IA2 01 TO SI NO PLUMES	.000	.000	.000	.000	SREF 3155.0000 SQ.FT.
(OBJ512)	◇	AMES 97-616 IA2 01 TO SI NO PLUMES	10.000	.000	10.000	.000	LREF 50.8000 FT.
(OBJ004)	◇	AMES 97-616 IA2 01 TO SI PC/PT NOM SRM A/A=8	.000	.000	.000	2.000	BREF 73.5000 FT.
(OBJ014)	△	AMES 97-616 IA2 01 TO SI PC/PT NOM SRM A/A=8	10.000	.000	10.000	2.000	XMRP 86.4167 FT.
(OBJ003)	△	AMES 97-616 IA2 01 TO SI PC/PT NOM	.000	.000	.000	3.000	YMRP .0000 FT.
(OBJ016)	△	AMES 97-616 IA2 01 TO SI PC/PT NOM	10.000	.000	10.000	3.000	ZMRP 4.0000 FT.
							SCALE .0190

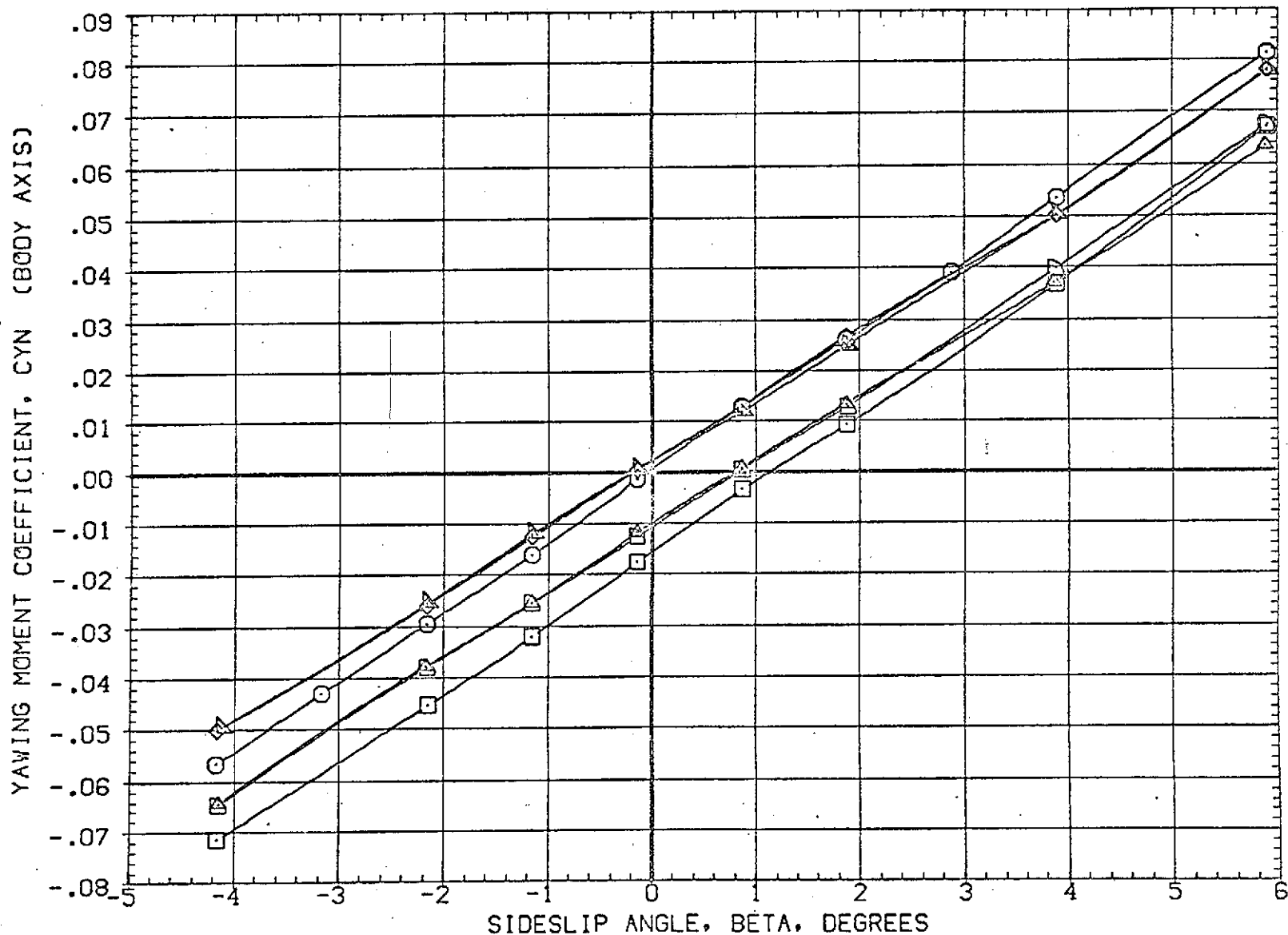

FIG 24 EFFECT OF ORBITER AND SRM PLUMES ON ELEVON AND RUDDER POWER, ALPHA=0.0
 (A)MACH = 1.60

DATA SET SYMBOL	CONFIGURATION DESCRIPTION	ELEVON	AILRON	RUDDER	PLUMES	REFERENCE INFORMATION
(DBJ502)	AMES 97-616 1A2 01 TO S1 NO PLUMES	.000	.000	.000	.000	SREF 3155.0000 SQ.FT.
(DBJ512)	AMES 97-616 1A2 01 TO S1 NO PLUMES	10.000	.000	10.000	.000	LREF 50.8000 FT.
(RBJ004)	AMES 97-616 1A2 01 TO S1 PC/PT NOM. SRM A/A-8	.000	.000	.000	2.000	BREF 73.5000 FT.
(RBJ014)	AMES 97-616 1A2 01 TO S1 PC/PT=NOM. SRM A/A-8	10.000	.000	10.000	2.000	XMRP 86.4167 FT.
(DBJ006)	AMES 97-616 1A2 01 TO S1 PC/PT NOM	.000	.000	.000	3.000	YMRP .0000 FT.
(DBJ016)	AMES 97-616 1A2 01 TO S1 PC/PT NOM	10.000	.000	10.000	3.000	ZMRP 4.0000 FT.
						SCALE .0190

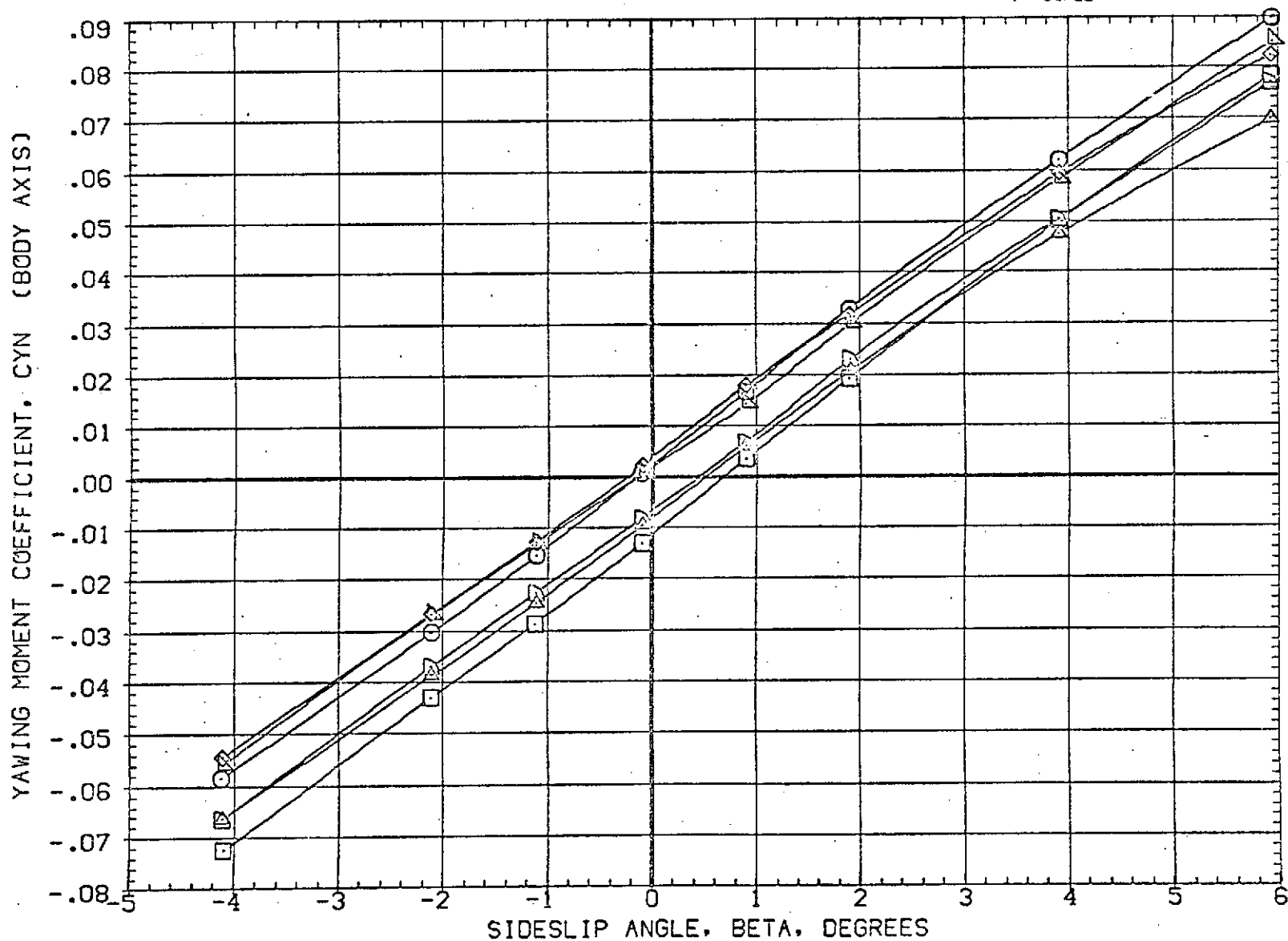

FIG 24 EFFECT OF ORBITER AND SRM PLUMES ON ELEVON AND RUDDER POWER, ALPHA=0.0

(B)MACH = 1.98

DATA SET SYMBOL	CONFIGURATION DESCRIPTION	ELEVON	AILRON	RUDDER	PLUMES	REFERENCE INFORMATION
(DBJ502)	AMES 97-616 1A2 01 TO S1 NO PLUMES	.000	.000	.000	.000	SREF 3155.0000 SQ.FT.
(DBJ512)	AMES 97-616 1A2 01 TO S1 NO PLUMES	10.000	.000	10.000	.000	LREF 50.8000 FT.
(RBJ004)	AMES 97-616 1A2 01 TO S1 PC/PT NOM. SRM A/A=8	.000	.000	.000	2.000	BREF 73.5000 FT.
(RBJ014)	AMES 97-616 1A2 01 TO S1 PC/PT NOM. SRM A/A=8	10.000	.000	10.000	2.000	XMRP 86.4167 FT.
(DBJ006)	AMES 97-616 1A2 01 TO S1 PC/PT NOM	.000	.000	.000	3.000	YMRP .0000 FT.
(DBJ016)	AMES 97-616 1A2 01 TO S1 PC/PT NOM	10.000	.000	10.000	3.000	ZMRP 4.0000 FT.
						SCALE .0190

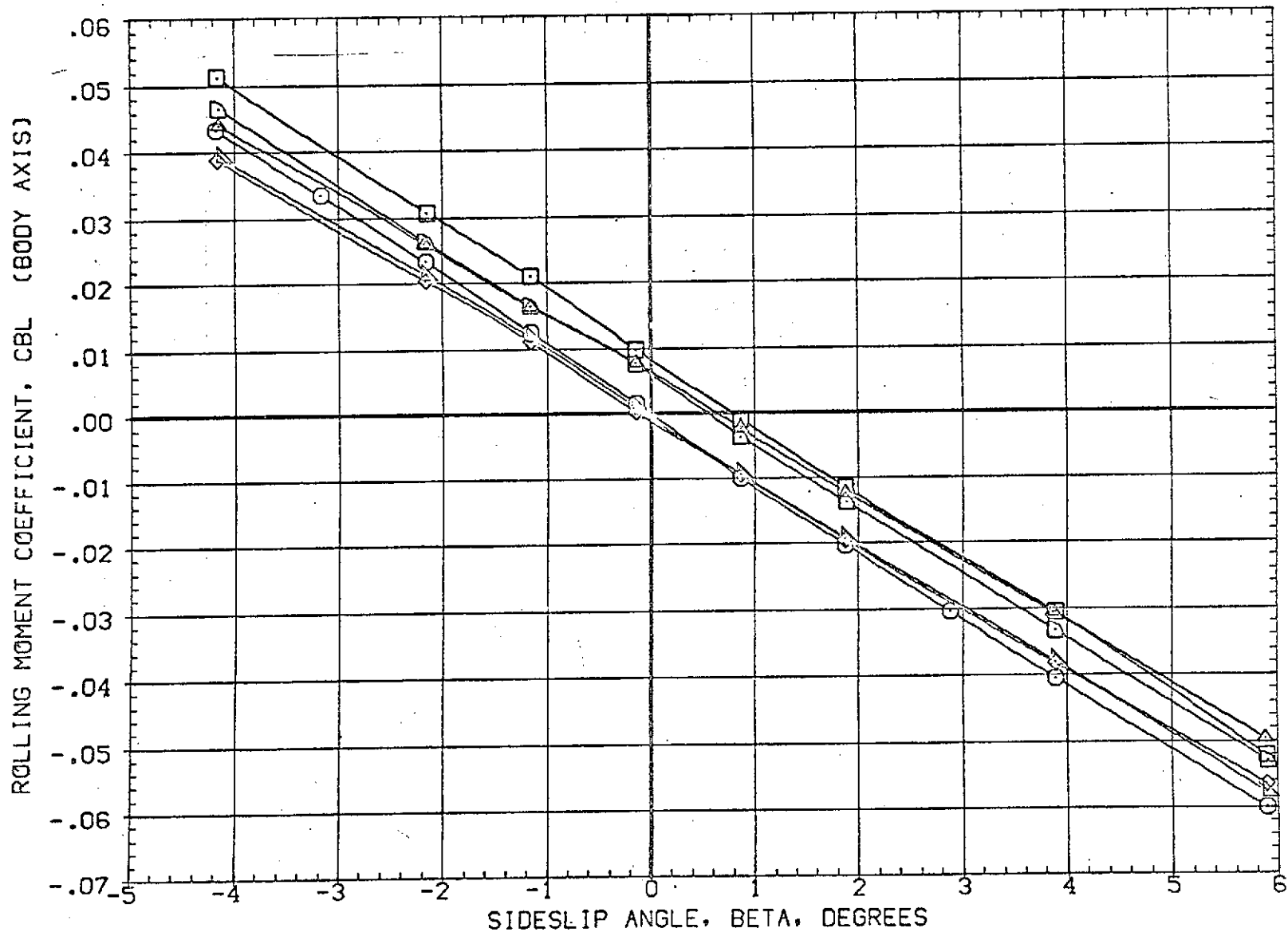

FIG 24 EFFECT OF ORBITER AND SRM PLUMES ON ELEVON AND RUDDER POWER, ALPHA=0.0
 (A)MACH = 1.60

DATA SET SYMBOL	CONFIGURATION DESCRIPTION	ELEVON	AILRON	RUDDER	PLUMES	REFERENCE INFORMATION
(03J502)	AMES 97-616 1A2 01 TO S1 NO PLUMES	.000	.000	.000	.000	SREF 3155.0000 SQ.FT.
(03J512)	AMES 97-616 1A2 01 TO S1 NO PLUMES	10.000	.000	10.000	.000	LREF 50.8000 FT.
(03J004)	AMES 97-616 1A2 01 TO S1 PC/PT NOM, SRM A/A-8	.000	.000	.000	2.000	BREF 73.5000 FT.
(03J014)	AMES 97-616 1A2 01 TO S1 PC/PT NOM, SRM A/A-8	10.000	.000	10.000	2.000	XMRP 86.4167 FT.
(03J006)	AMES 97-616 1A2 01 TO S1 PC/PT NOM	.000	.000	.000	3.000	YMRP .0000 FT.
(03J016)	AMES 97-616 1A2 01 TO S1 PC/PT NOM	10.000	.000	10.000	3.000	ZMRP 4.0000 FT.
						SCALE .0190

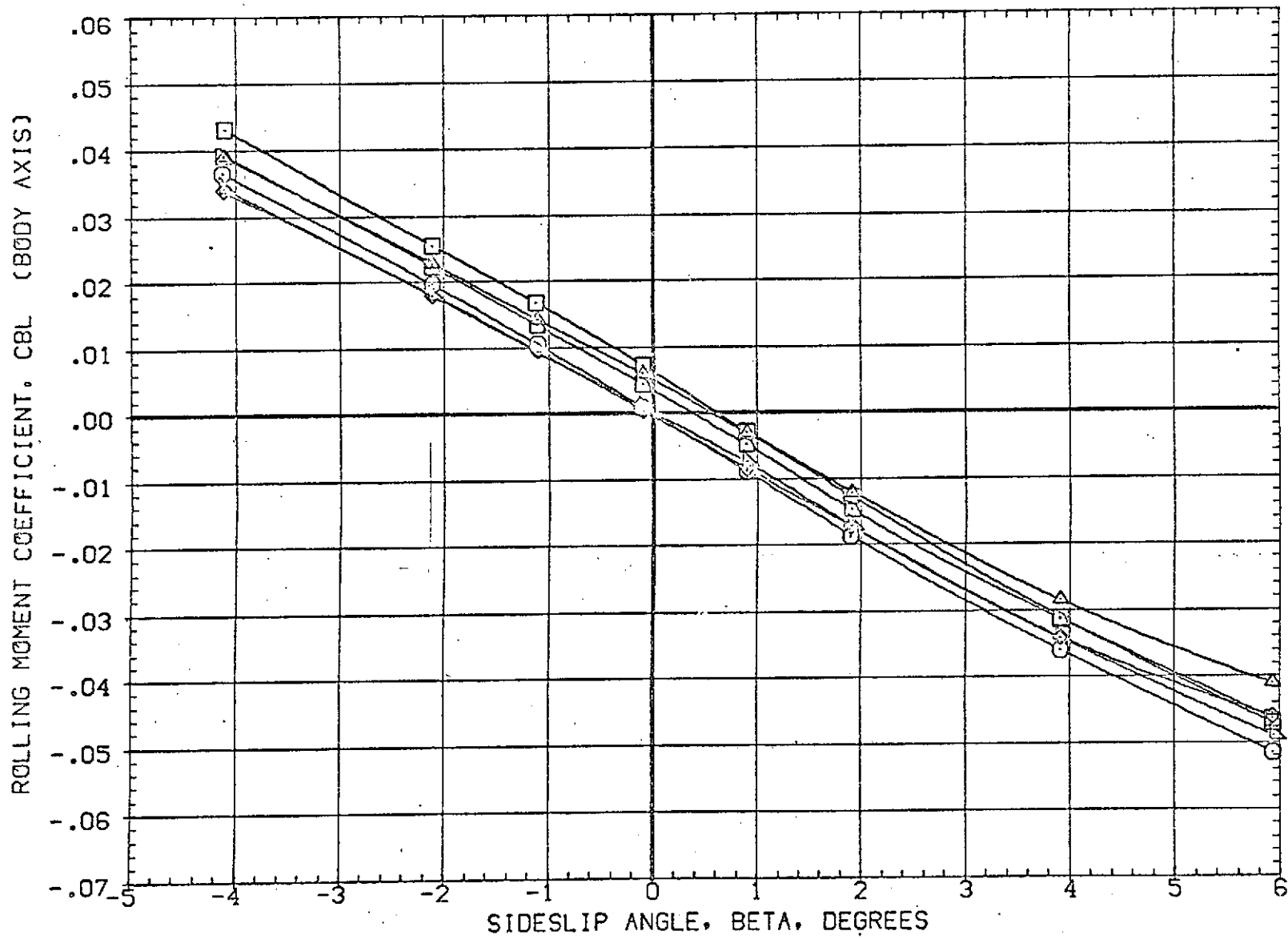

FIG 24 EFFECT OF ORBITER AND SRM PLUMES ON ELEVON AND RUDDER POWER, ALPHA=0.0

(B)MACH = 1.98

DATA SET SYMBOL	CONFIGURATION DESCRIPTION	ELEVON	AILRON	RUDDER	PLUMES	REFERENCE INFORMATION
(DBJ502)	AMES 97-616 IA2 01 TO S1 NO PLUMES	.000	.000	.000	.000	SREF 3155.0000 SQ.FT.
(DBJ512)	AMES 97-616 IA2 01 TO S1 NO PLUMES	10.000	.000	10.000	.000	LREF 50.8000 FT.
(RBJ004)	AMES 97-616 IA2 01 TO S1 PC/PT NOM, SRM A/A-8	.000	.000	.000	2.000	BREF 73.5000 FT.
(RBJ014)	AMES 97-616 IA2 01 TO S1 PC/PT NOM, SRM A/A-8	10.000	.000	10.000	2.000	XMRP 86.4167 FT.
(DBJ006)	AMES 97-616 IA2 01 TO S1 PC/PT NOM	.000	.000	.000	3.000	YMRP .0000 FT.
(DBJ016)	AMES 97-616 IA2 01 TO S1 PC/PT NOM	10.000	.000	10.000	3.000	ZMRP 4.0000 FT.
						SCALE .0190

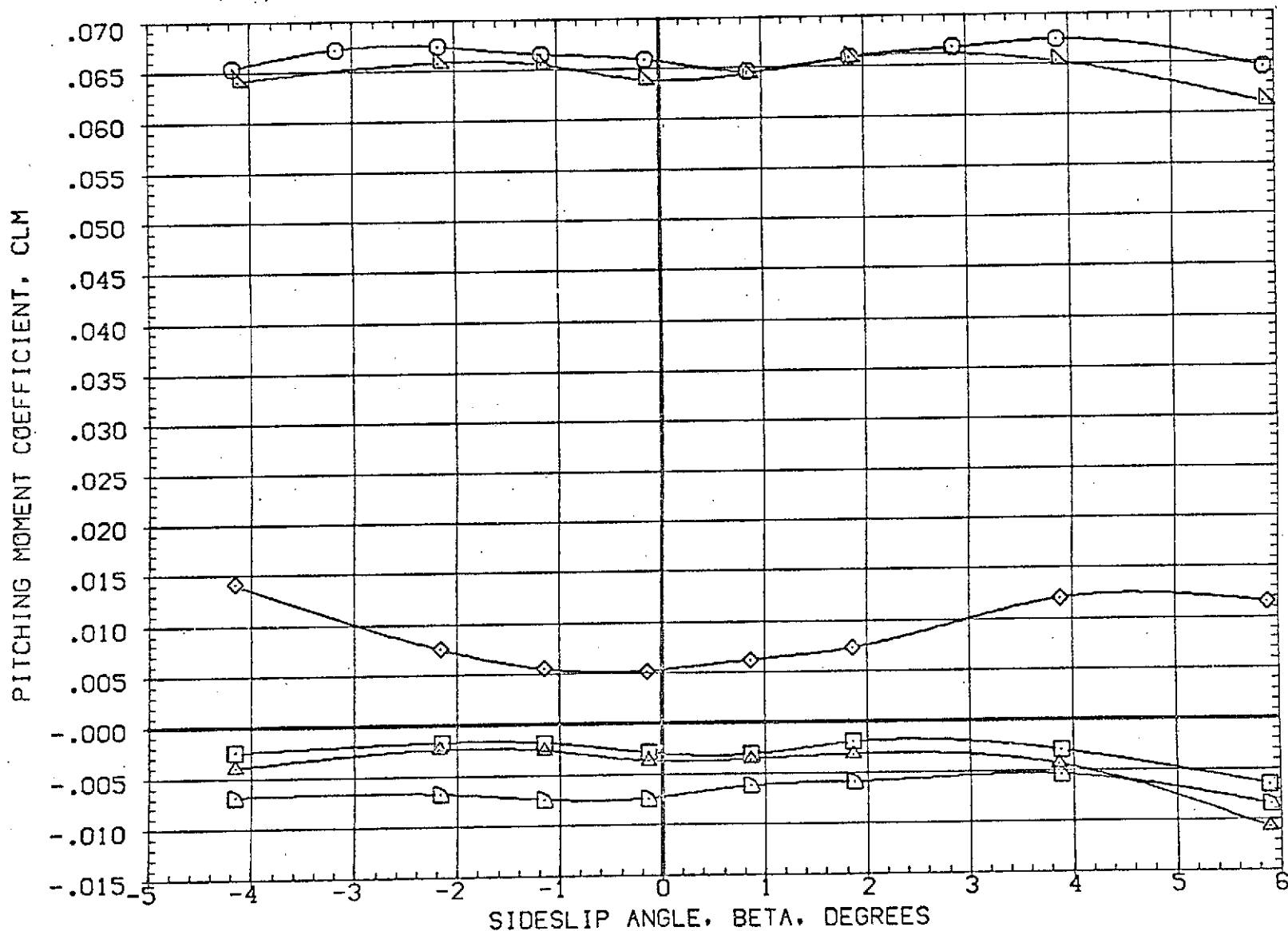

FIG 24 EFFECT OF ORBITER AND SRM PLUMES ON ELEVON AND RUDDER POWER, ALPHA=0.0

(A)MACH = 1.60

(C9J502)	AMES 97-616 IA2 01 TO SI NO PLUMES	.000	.000	.000	.000	SREF	3155.0000	sq. FT.
(C9J512)	AMES 97-616 IA2 01 TO SI NO PLUMES	10.000	.000	10.000	.000	LREF	50.8000	FT.
(R9J004)	AMES 97-616 IA2 01 TO SI PC/PT NOM, SRM A/A-8	.000	.000	.000	2.000	BREF	73.5000	FT.
(R9J014)	AMES 97-616 IA2 01 TO SI PC/PT=NOY, SRM A/A-8	10.000	.000	10.000	2.000	XM RP	86.4167	FT.
(C9J003)	AMES 97-616 IA2 01 TO SI PC/PT NOM	.000	.000	.000	3.000	YM RP	.0000	FT.
(C9J016)	AMES 97-616 IA2 01 TO SI PC/PT NOM	10.000	.000	10.000	3.000	ZM RP	4.0000	FT.
						SCALE	.0190	

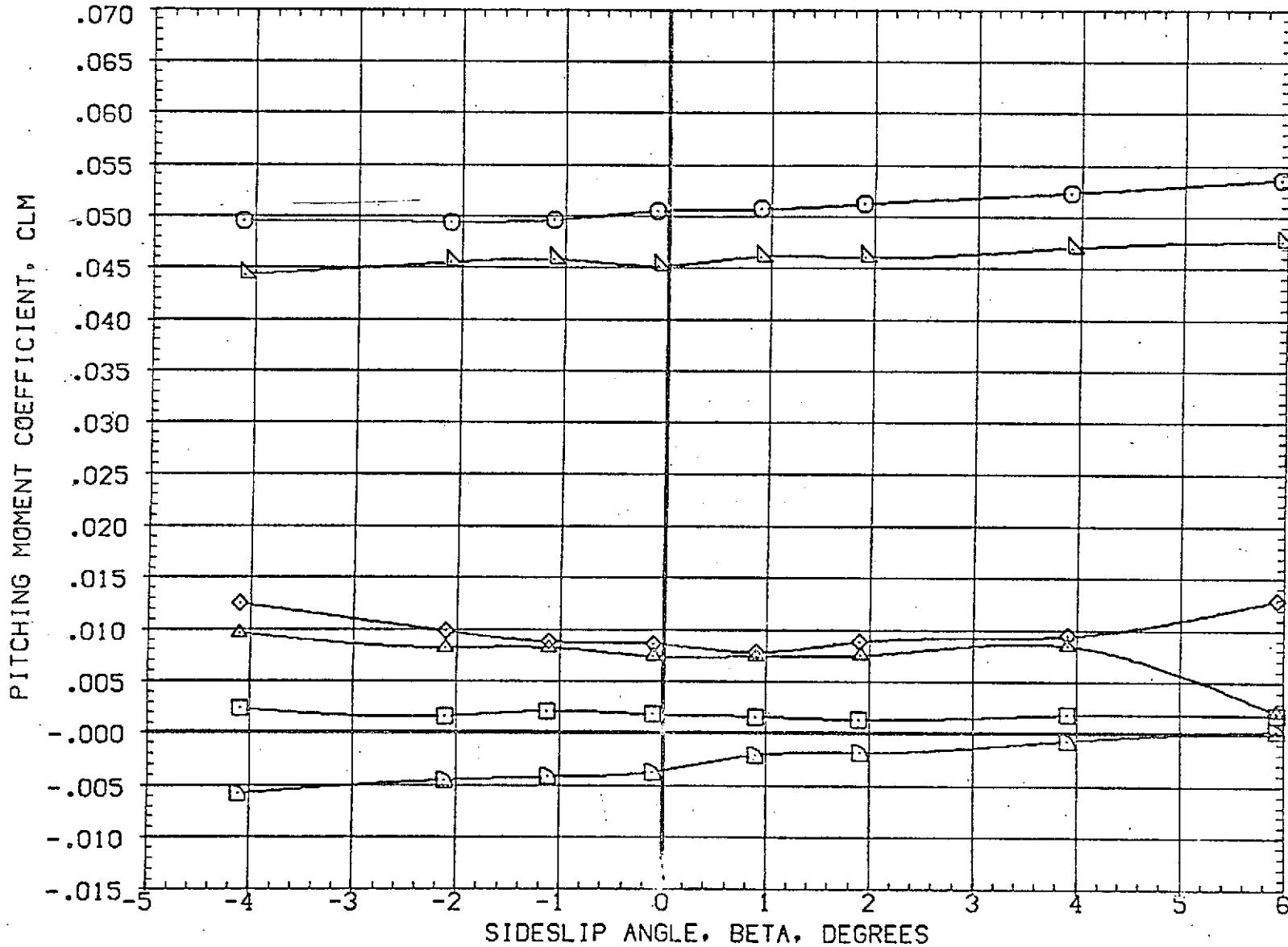

FIG 24 EFFECT OF ORBITER AND SRM PLUMES ON ELEVON AND RUDDER POWER, ALPHA=0.0

(B)MACH = 1.98

DATA SET SYMBOL	CONFIGURATION DESCRIPTION	ELEVON	AILRON	RUDDER	PLUMES	REFERENCE INFORMATION
(DBJ502)	AMES 97-616 IA2 01 TO S1 NO PLUMES	.000	.000	.000	.000	SREF 3155.0000 SQ.FT.
(DBJ512)	AMES 97-616 IA2 01 TO S1 NO PLUMES	10.000	.000	10.000	.000	LREF 50.8000 FT.
(RBJ004)	AMES 97-616 IA2 01 TO S1 PC/PT NOM. SRM A/A=8	.000	.000	.000	2.000	BREF 73.5000 FT.
(RBJ014)	AMES 97-616 IA2 01 TO S1 PC/PT-NOM. SRM A/A=8	10.000	.000	10.000	2.000	XMRP 86.4167 FT.
(DBJ006)	AMES 97-616 IA2 01 TO S1 PC/PT NOM	.000	.000	.000	3.000	YMRP .0000 FT.
(DBJ016)	AMES 97-616 IA2 01 TO S1 PC/PT NOM	10.000	.000	10.000	3.000	ZMRP 4.0000 FT.
						SCALE .0190

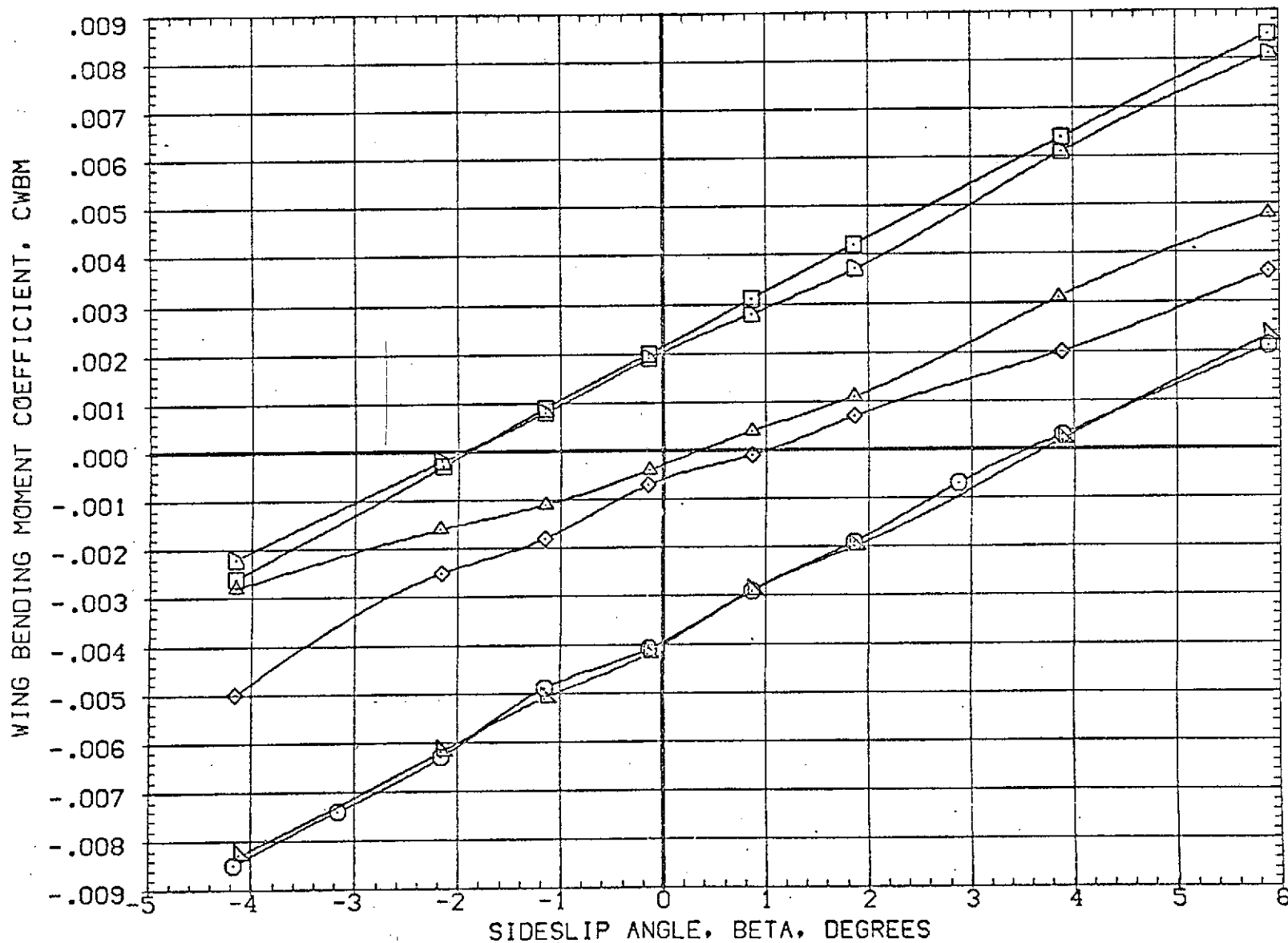

FIG 24 EFFECT OF ORBITER AND SRM PLUMES ON ELEVON AND RUDDER POWER, ALPHA=0.0

(A)MACH = 1.60

DATA SET SYMBOL	SYMBOL	CONFIGURATION DESCRIPTION	ELEVON	AILRON	RUDDER	PLUMES	REFERENCE INFORMATION		
(DBJ502)	□	AMES 97-616 1A2 01 TO S1 NO PLUMES	.000	.000	.000	.000	SREF	3155.0000	SQ.FT.
(DBJ512)	□	AMES 97-616 1A2 01 TO S1 NO PLUMES	10.000	.000	10.000	.000	LREF	50.8000	FT.
(RBJ004)	◇	AMES 97-616 1A2 01 TO S1 PC/PT-NGM,SRM A/A-8	.000	.000	.000	2.000	SREF	73.5000	FT.
(RBJ014)	◇	AMES 97-616 1A2 01 TO S1 PC/PT-NGM,SRM A/A-8	10.000	.000	10.000	2.000	XMRP	86.4167	FT.
(DBJ036)	△	AMES 97-616 1A2 01 TO S1 PC/PT NOM	.000	.000	.000	3.000	YMRP	.0000	FT.
(DBJ016)	△	AMES 97-616 1A2 01 TO S1 PC/PT NOM	10.000	.000	10.000	3.000	ZMRP	4.0000	FT.
							SCALE	.0190	

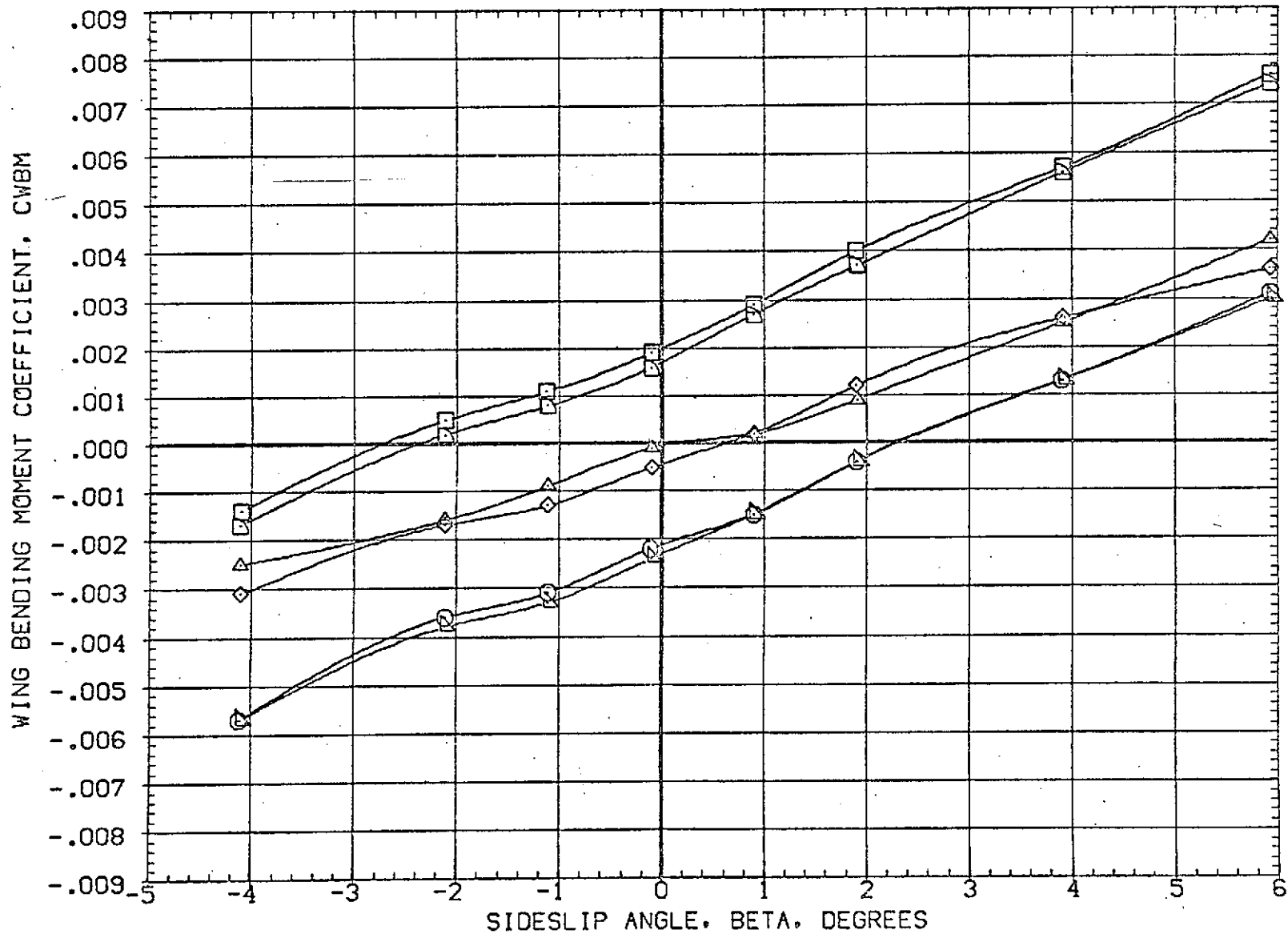

FIG 24 EFFECT OF ORBITER AND SRM PLUMES ON ELEVON AND RUDDER POWER, ALPHA=0.0
 (B)MACH = 1.98

SYMBOL	MACH	BETA	PARAMETRIC VALUES
○	1.600		.000
□	2.000		
◇	2.200		

REFERENCE INFORMATION		
SREF	3155.0000	SQ.FT.
LREF	50.8000	FT.
BREF	73.5000	FT.
XMRP	86.4167	FT.
YMRP	.0000	FT.
ZMRP	4.0000	FT.
SCALE	.0190	

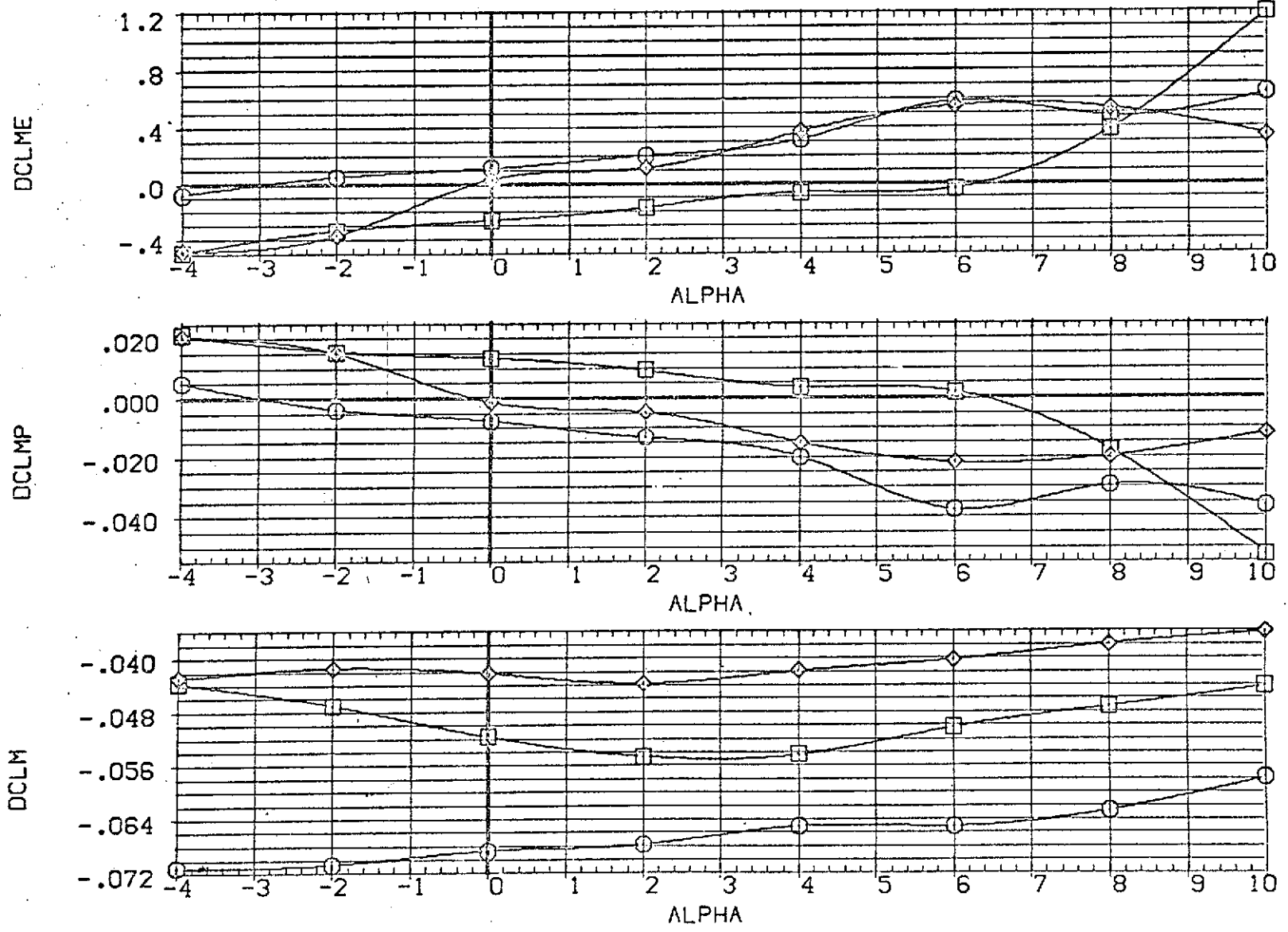

FIG 25 EFFECT OF PLOMES ON ELEVON EFFECTIVENESS

SYMBOL MACH BETA PARAMETRIC VALUES
 ○ 1.600 .000
 □ 2.000

REFERENCE INFORMATION
 SREF 3155.0000 SQ.FT.
 LREF 50.8000 FT.
 BREF 73.5000 FT.
 XMRP 86.4167 FT.
 YMRP .0000 FT.
 ZMRP 4.0000 FT.
 SCALE .0190

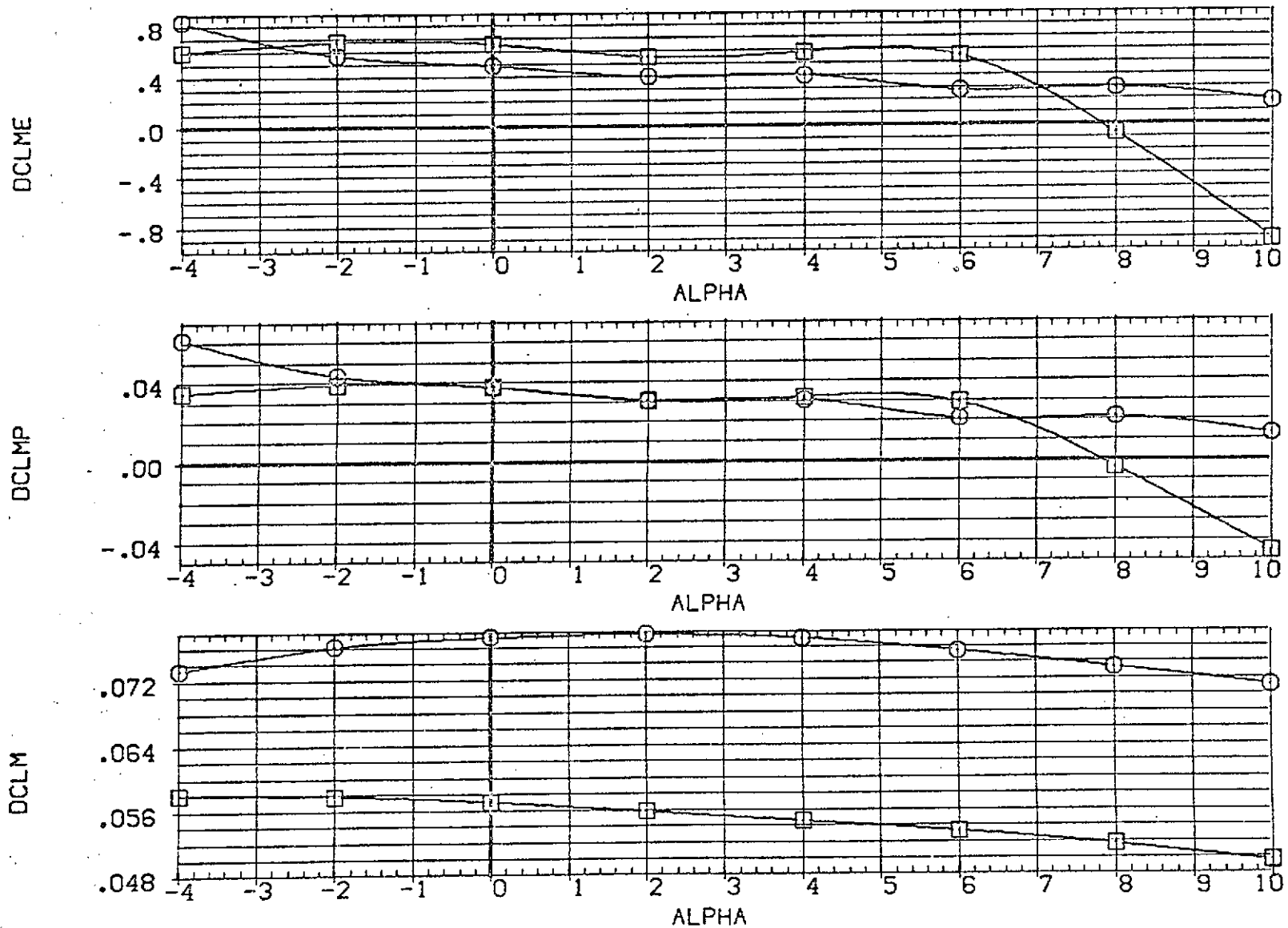

FIG 25 EFFECT OF PLOMES ON ELEVON EFFECTIVENESS

SYMBOL MACH BETA PARAMETRIC VALUES
 ○ 1.600 .000
 □ 2.000

REFERENCE INFORMATION
 SREF 3155.0000 SQ.FT.
 LREF 50.8000 FT.
 BREF 73.5000 FT.
 XMRP 86.4167 FT.
 YMRP .0000 FT.
 ZMRP 4.0000 FT.
 SCALE .0190

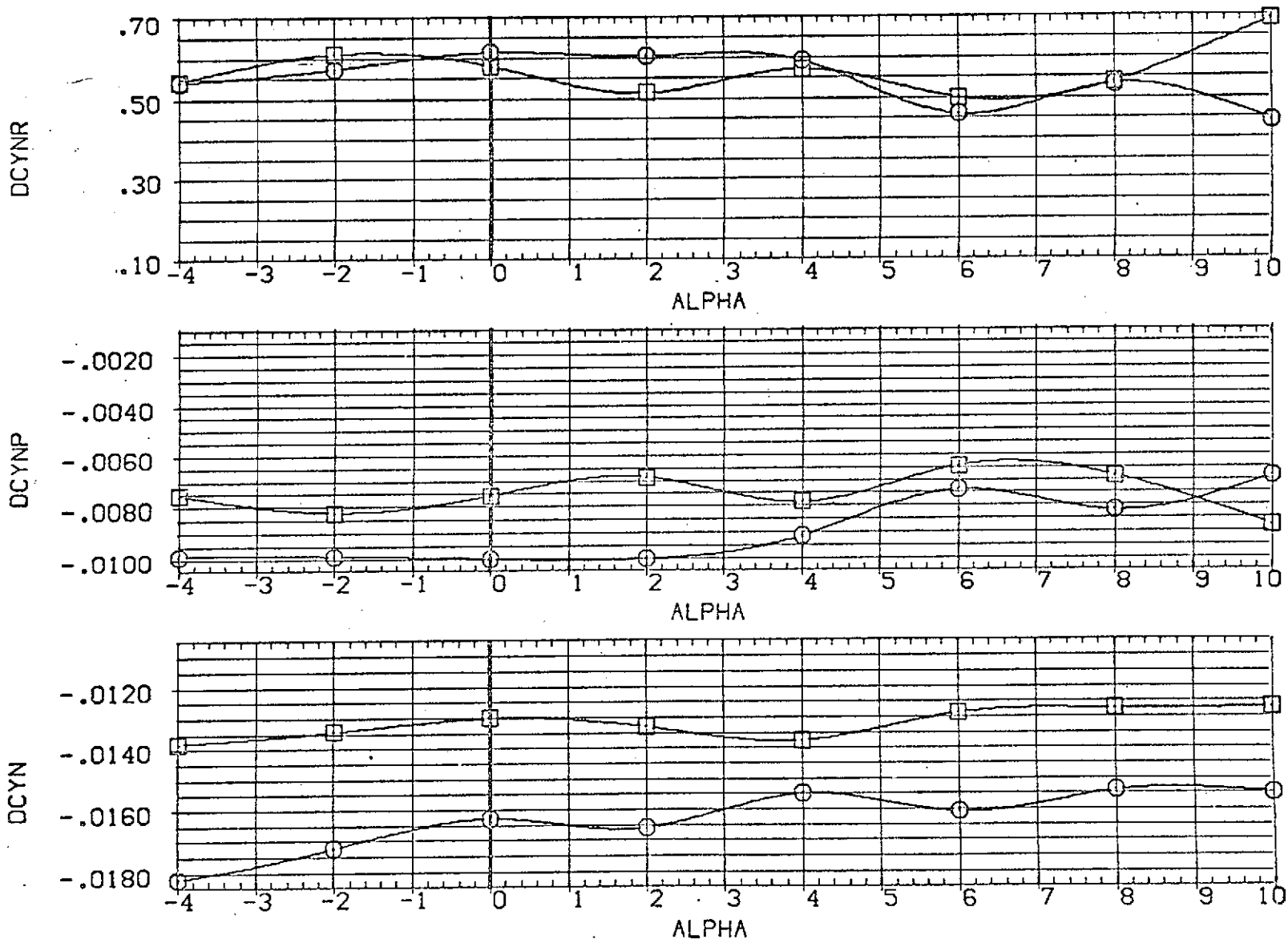

FIG 26 EFFECT OF PLOMES ON RUDDER EFFECTIVENESS

SYMBOL MACH PARAMETRIC VALUES
 ○ 2.200 BETA .000

REFERENCE INFORMATION
 SREF 3155.0000 SQ.FT.
 LREF 50.8000 FT.
 BREF 73.5000 FT.
 XMRP 86.4167 FT.
 YMRP .0000 FT.
 ZMRP 4.0000 FT.
 SCALE .0190

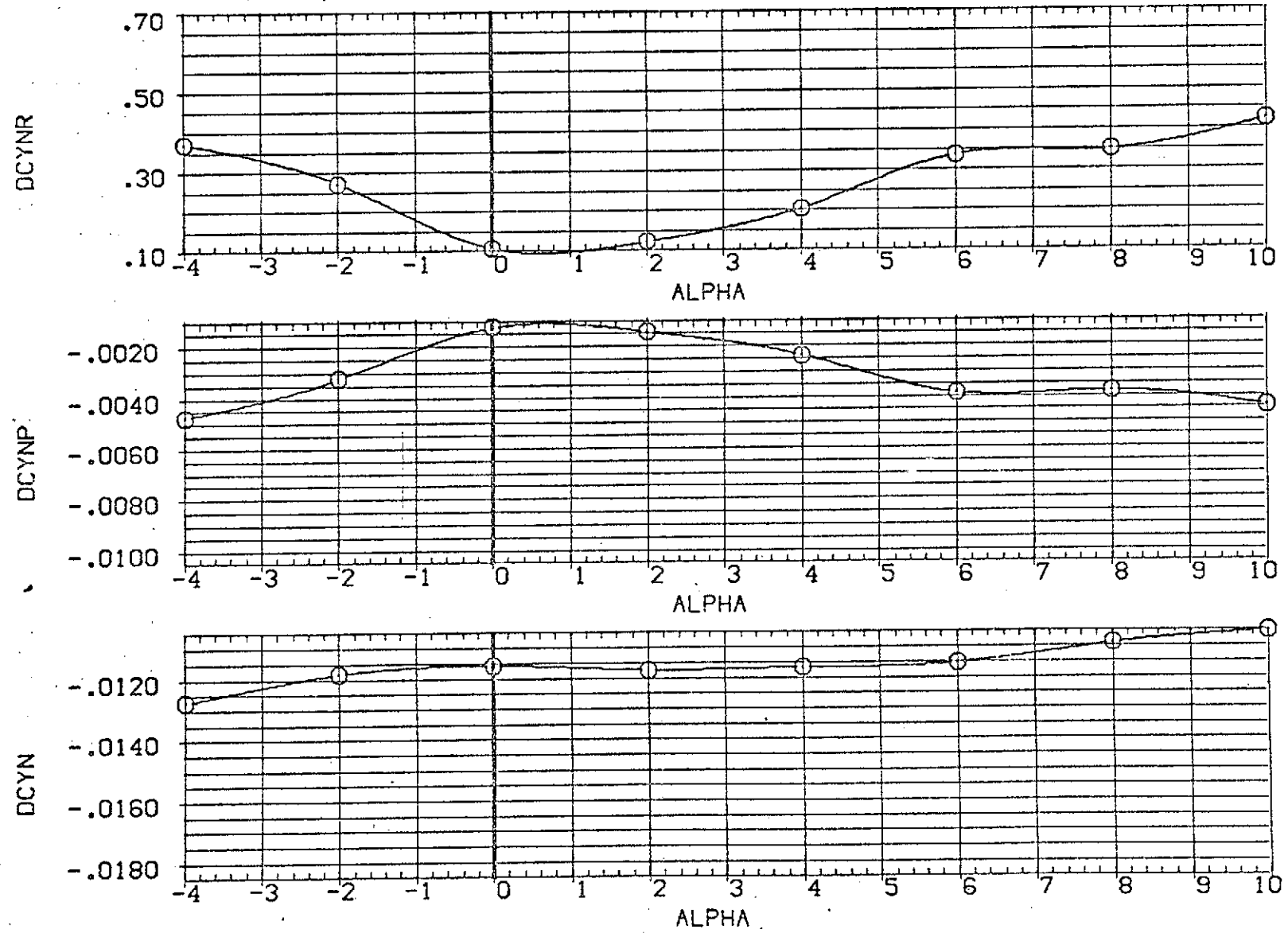

FIG 26 EFFECT OF PLUMES ON RUDDER EFFECTIVENESS

SYMBOL MACH BETA PARAMETRIC VALUES
 ○ 1.600 .000
 □ 2.000

REFERENCE INFORMATION
 SREF 3155.0000 SQ.FT.
 LREF 50.8000 FT.
 BREF 73.5000 FT.
 XMRP 86.4167 FT.
 YMRP .0000 FT.
 ZMRP 4.0000 FT.
 SCALE .0190

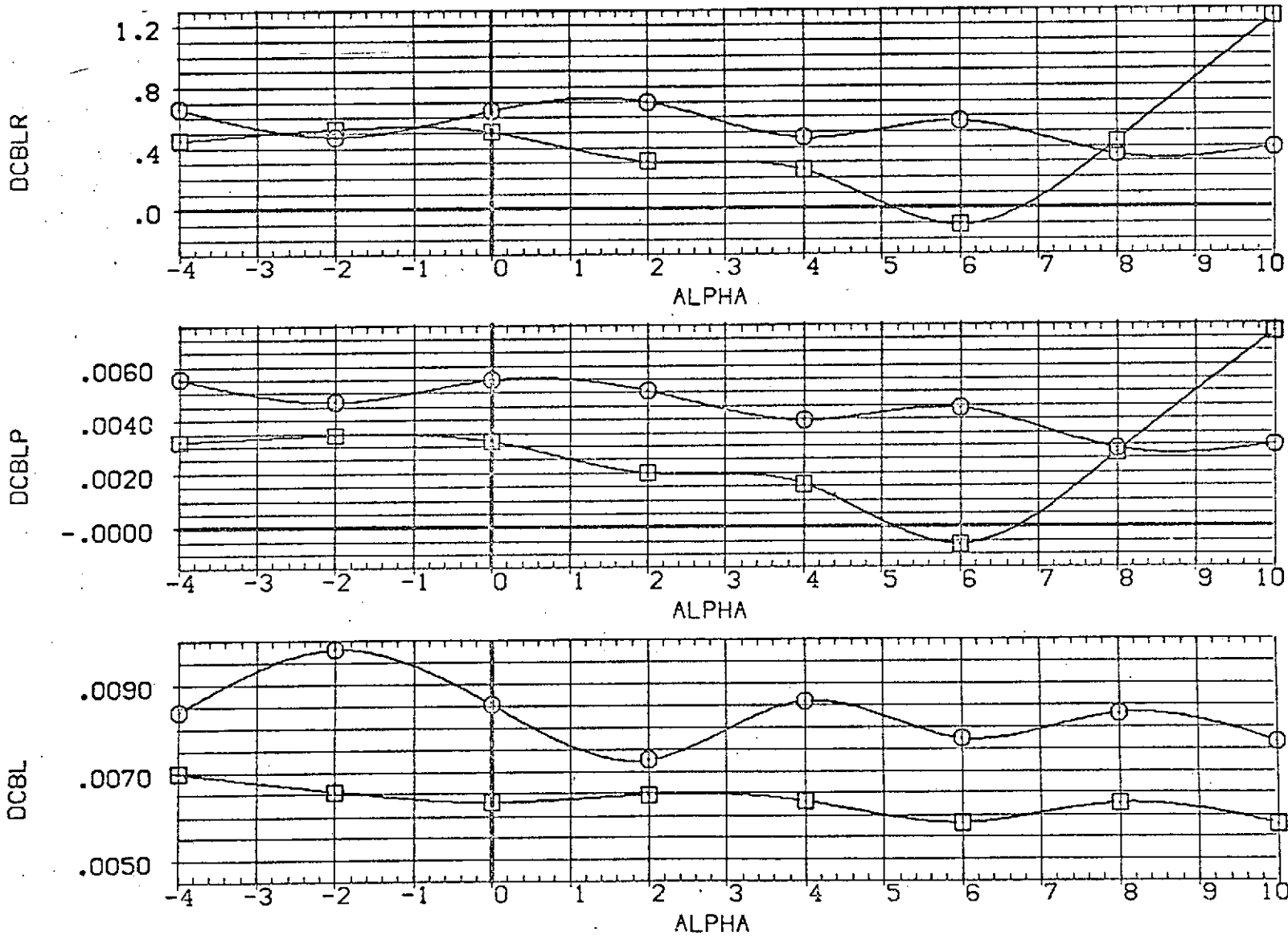

FIG 26 EFFECT OF PLUMES ON RUDDER EFFECTIVENESS

SYMBOL MACH PARAMETRIC VALUES
 O 2.200 BETA .000

REFERENCE INFORMATION
 SREF 3155.0000 SQ.FT.
 LREF 50.8000 FT.
 BREF 73.5000 FT.
 XMRP 86.4167 FT.
 YMRP .0000 FT.
 ZMRP 4.0000 FT.
 SCALE .0190

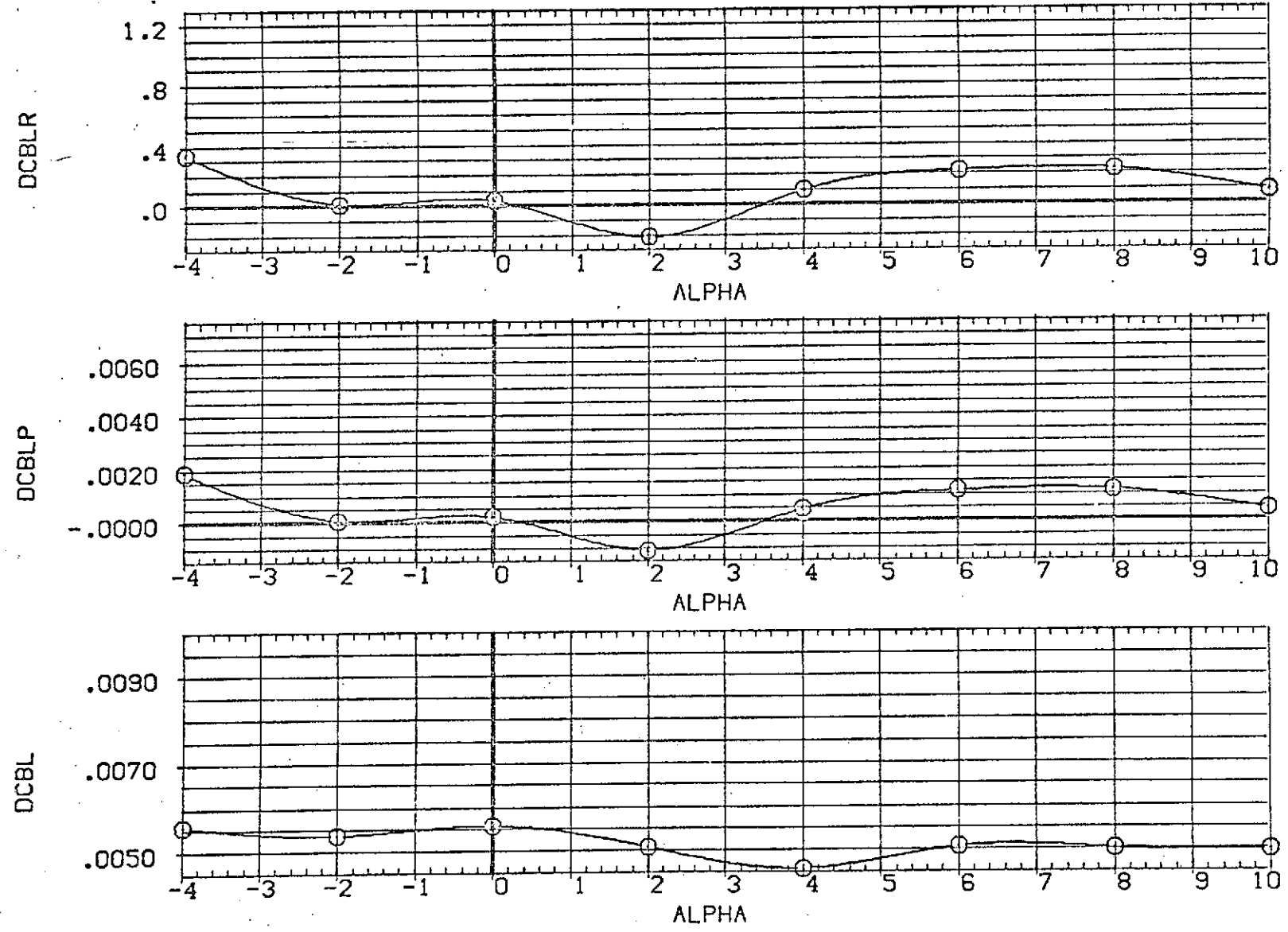

FIG 26 EFFECT OF PLOMES ON RUDDER EFFECTIVENESS

SYMBOL MACH ALPHA PARAMETRIC VALUES
 ○ 1.600
 □ 2.000

REFERENCE INFORMATION
 SREF 3155.0000 SQ.FT.
 LREF 50.8000 FT.
 BREF 73.5000 FT.
 XMRP 86.4167 FT.
 YMRP .0000 FT.
 ZMRP 4.0000 FT.
 SCALE .0190

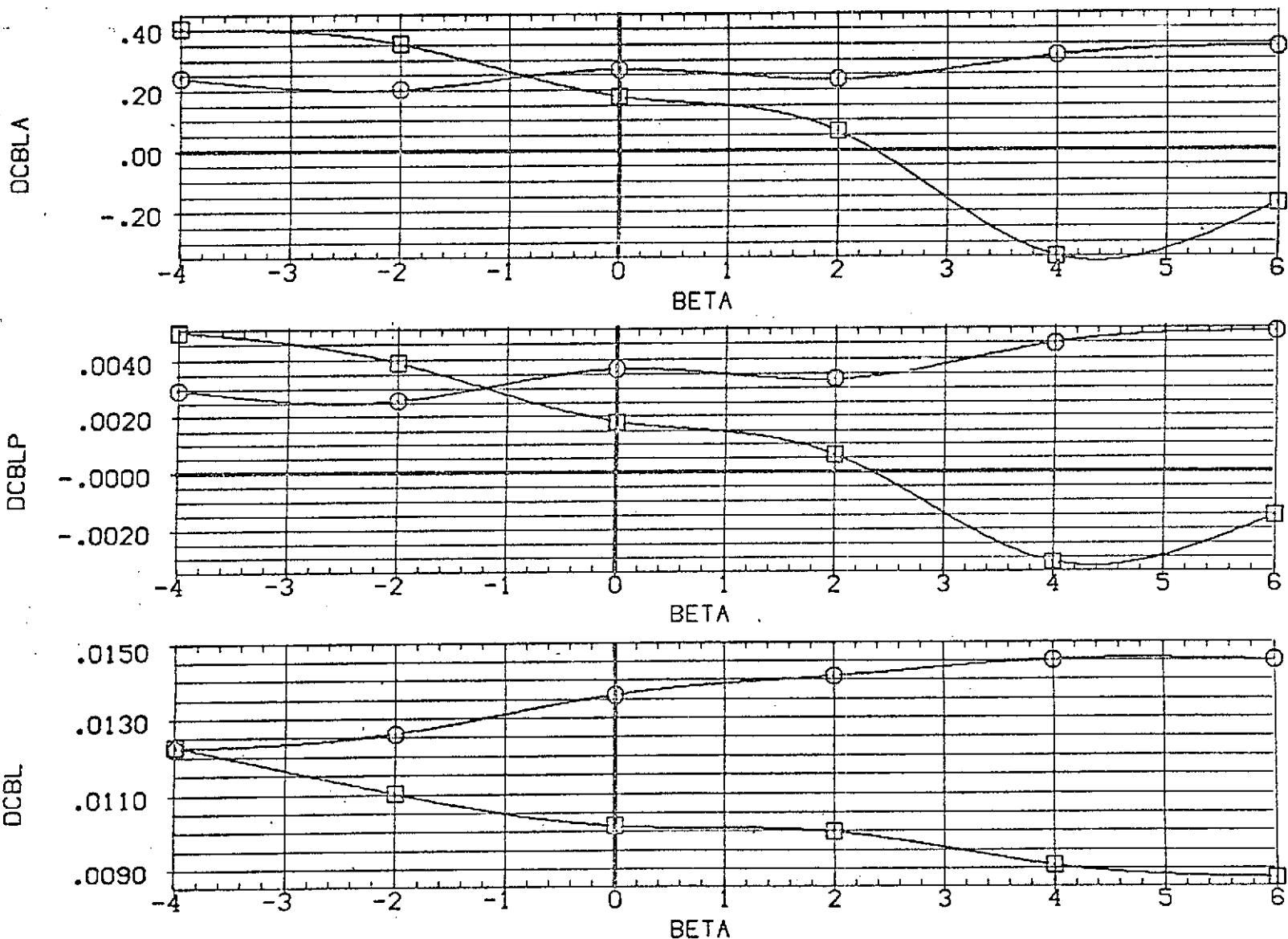

FIG 27 EFFECT OF PLUMES ON AILERON EFFECTIVENESS

SYMBOL MACH ALPHA PARAMETRIC VALUES
 ○ 1.600
 □ 2.000

REFERENCE INFORMATION
 SREF 3155.0000 SQ.FT.
 LREF 50.8000 FT.
 BREF 73.5000 FT.
 XMRP 86.4167 FT.
 YMRP .0000 FT.
 ZMRP 4.0000 FT.
 SCALE .0190

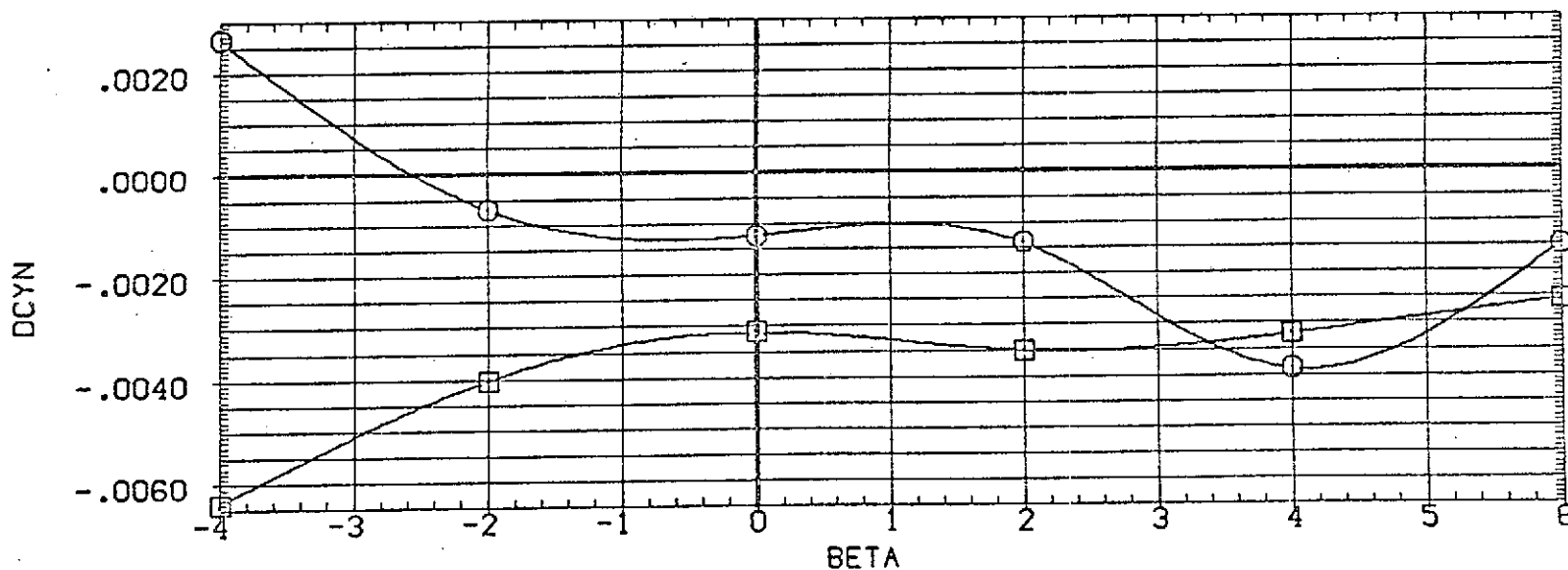
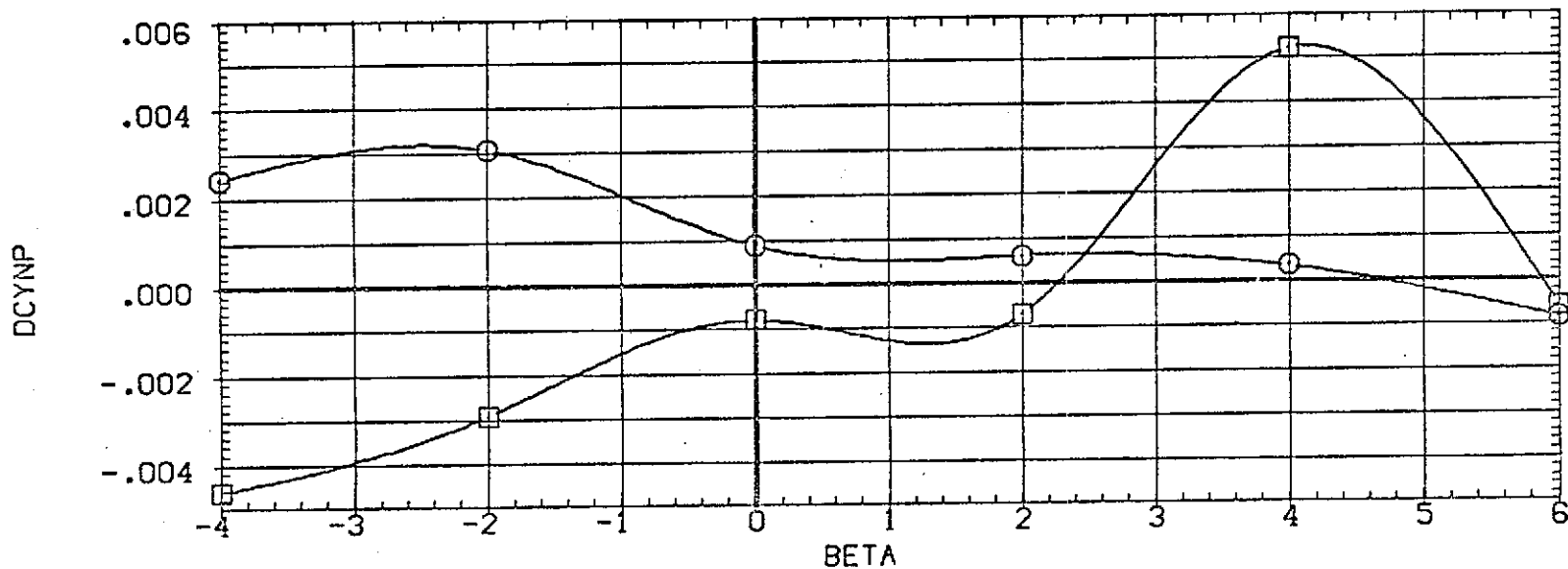

FIG 27 EFFECT OF PLUMES ON AILERON EFFECTIVENESS

APPENDIX

TABULATED DATA LISTING

Tabulation of plotted data are available on request from
Data Management Services

AMES 97-616 IAZ 01 TO S1 FC/PT NOM,SRM A/A=8

(RBJ001) (23 JAN 73)

REFERENCE DATA

SREF = 3155.0000 SQ.FT. XMRP = 86.4167 FT.
 LREF = 50.8000 FT. YMRP = .0000 FT.
 BREF = 73.5000 FT. ZMRP = 4.0000 FT.
 SCALE = .0190

PARAMETRIC DATA

BETA = .000 ELEVON = .000
 AILRON = .000 RUDDER = .000
 PLUMES = 5.000

RUN NO. 2/ 0 RN/L = 2.54 GRADIENT INTERVAL = -5.00/ 5.00

MACH	ALPHA	CN	CAF	CLM	CWBM	CY	CYN	CBL	CABORB	CABTNK	CABSRM
1.600	-4.090	-.20300	.16160	-.02130	-.00250	.00080	-.00070	.00040	.00010	.00460	.00160
1.600	-3.110	-.17500	.15930	-.00650	-.00370	.00250	.00020	.00030	.00190	.00240	.00070
1.600	-2.090	-.14300	.15690	.00440	-.00430	.00210	-.00010	.00120	.00180	.00210	.00120
1.600	-1.090	-.10500	.15400	-.00040	-.00200	.00490	-.00110	-.00020	.00150	.00330	.00180
1.600	-.090	-.06800	.15110	-.00020	-.00060	.00380	-.00030	.00070	.00140	.00190	.00150
1.600	.880	-.03200	.14910	-.00140	.00090	.00270	.00020	.00040	.00090	.00100	.00120
1.600	1.880	.00700	.14640	-.00770	.00300	.00190	.00090	-.00020	.00000	.00090	.00080
1.600	2.900	.04700	.14660	-.01080	.00480	-.00100	.00100	-.00030	.00240	.00130	.00130
1.600	3.930	.08800	.14470	-.01910	.00790	-.00030	.00160	.00000	.00290	.00150	.00130
1.600	5.920	.16100	.14280	-.02430	.01000	-.00310	.00240	-.00100	.00350	-.00020	.00080
1.600	7.930	.23700	.14010	-.02540	.01100	-.00800	.00290	.00030	.00170	-.00230	.00020
1.600	9.950	.30100	.13720	-.00890	.01130	-.00600	.00160	-.00110	.00040	-.00240	.00030
GRADIENT		.03671	-.00219	-.00049	.00141	-.00033	.00025	-.00009	.00014	-.00034	-.00001

RUN NO. 31/ 0 RN/L = 2.07 GRADIENT INTERVAL = -5.00/ 5.00

MACH	ALPHA	CN	CAF	CLM	CWBM	CY	CYN	CBL	CABORB	CABTNK	CABSRM
1.985	-3.810	-.20600	.15100	-.01860	-.00180	-.00650	.00460	-.00060	-.00770	-.01210	-.00280
1.985	-1.800	-.13500	.14400	-.01380	-.00070	-.00670	.00570	-.00140	-.00780	-.01390	-.00320
1.985	-.800	-.10000	.14150	-.01280	-.00040	-.00700	.00550	-.00090	-.00760	-.01440	-.00320
1.985	.180	-.06600	.13990	-.01540	.00070	-.00690	.00530	-.00090	-.00780	-.01540	-.00350
1.985	1.190	-.02800	.13750	-.01690	.00200	-.00620	.00520	-.00090	-.00790	-.01550	-.00340
1.985	2.220	.01200	.13620	-.01930	.00380	-.00710	.00550	-.00040	-.00830	-.01670	-.00360
1.985	4.220	.08500	.13310	-.02080	.00750	-.00890	.00630	-.00060	-.00860	-.01730	-.00380
1.985	6.250	.15500	.12960	-.01860	.00890	-.01000	.00700	.00020	-.00930	-.01910	-.00460
1.985	8.220	.20400	.12730	.01390	.00900	-.01180	.00740	-.00350	-.01030	-.01850	-.00410
GRADIENT		.03630	-.00216	-.00057	.00115	-.00023	.00014	.00005	-.00012	-.00065	-.00012

RUN NO. 44/ 0 RN/L = 1.73 GRADIENT INTERVAL = -5.00/ 5.00

MACH	ALPHA	CN	CAF	CLM	CWBM	CY	CYN	CBL	CABORB	CABTNK	CABSRM
2.170	-3.500	-.19700	.15030	-.01350	.00030	-.01100	.00550	-.00130	-.00840	-.01370	-.00330
2.170	-1.460	-.12000	.14460	-.01040	.00070	-.00940	.00560	-.00120	-.00900	-.01690	-.00390
2.170	-.460	-.08400	.14160	-.00460	.00080	-.00840	.00500	-.00160	-.00890	-.01680	-.00380
2.170	.530	-.04600	.13810	-.00420	.00160	-.00910	.00590	-.00100	-.00900	-.01790	-.00400
2.170	1.500	-.00800	.13590	-.00790	.00240	-.00860	.00570	-.00070	-.00900	-.01820	-.00410
2.170	2.540	.02900	.13270	-.01170	.00360	-.00840	.00540	-.00070	-.00900	-.01890	-.00410
2.170	4.560	.09500	.12740	-.00610	.00590	-.00980	.00680	-.00270	-.01000	-.02090	-.00480
2.170	6.500	.14700	.12360	.00900	.00640	-.00620	.00530	-.00230	-.01080	-.02050	-.00480
2.170	8.570	.20600	.12070	.02150	.00760	-.01290	.00780	-.00440	-.01090	-.02020	-.00460
2.170	10.560	.28500	.12140	.01870	.00910	-.01570	.00900	-.00430	-.01100	-.02160	-.00510
GRADIENT		.03634	-.00287	.00056	.00071	.00016	.00013	-.00009	-.00015	-.00081	-.00016

AMES 97-616 IAZ 01 TO S1 PC/PT NOM,SRM A/A=8

(RBJ002) (23 JAN 73)

REFERENCE DATA

SREF = 3155.0000 SQ.FT. XMRP = 88.4167 FT.
 LREF = 50.8000 FT. YMRP = .0000 FT.
 DREF = 73.5000 FT. ZMRP = 4.0000 FT.
 SCALE = .0190

PARAMETRIC DATA

ALPHA = .000 ELEVON = .000
 AILRON = .000 RUDDER = .000
 PLUMES = 5.000

RUN NO. 3/ 0 RN/L = 2.52 GRADIENT INTERVAL = -5.00/ 5.00

MACH	BETA	CN	CAF	CLM	CWBM	CY	CYN	CBL	CABORB	CABTNK	CABSRM
1.600	-4.180	-.07700	.15400	.00750	-.00530	.16860	-.04940	.03790	.00140	.00220	.00170
1.600	-3.170	-.08400	.15380	.00680	-.00420	.12840	-.03750	.02920	.00130	.00130	.00140
1.600	-2.160	-.08000	.15280	.00390	-.00280	.09120	-.02670	.02000	.00130	.00190	.00150
1.600	-1.150	-.07600	.15330	.00170	-.00190	.04770	-.01400	.01110	.00130	.00190	.00140
1.600	-.140	-.07600	.15200	.00120	-.00080	.00500	-.00080	.00090	.00100	.00050	.00120
1.600	.860	-.08500	.15260	.00090	.00010	-.03700	.01150	-.00870	.00120	.00160	.00120
1.600	1.870	-.07800	.15310	.00250	.00070	-.07680	.02330	-.01780	.00120	.00140	.00110
1.600	2.880	-.08200	.15370	.00570	.00140	-.11490	.03440	-.02730	.00110	.00110	.00120
1.600	3.890	-.08500	.15350	.00740	.00190	-.15800	.04720	-.03660	.00150	.00210	.00150
1.600	4.900	-.08400	.15330	.00840	.00340	-.24290	.07450	-.05430	.00180	.00400	.00170
1.600	5.920	-.08900	.15190	.00950	.00480	-.31430	.09420	-.06580	.00390	.00850	.00230
1.600	7.920	-.08900	.15190	.00950	.00480	-.31430	.09420	-.06580	.00390	.00850	.00230
GRADIENT		-.00051	-.00004	-.00012	.00090	-.04061	.01203	-.00930	-.00001	-.00004	-.00004

RUN NO. 34/ 0 RN/L = 2.07 GRADIENT INTERVAL = -5.00/ 5.00

MACH	BETA	CN	CAF	CLM	CWBM	CY	CYN	CBL	CABORB	CABTNK	CABSRM
1.985	-4.130	-.08300	.14520	.00530	-.00230	.14990	-.04720	.03090	-.00460	-.00820	-.00160
1.985	-2.120	-.07900	.14430	.00100	-.00120	.07300	-.02240	.01540	-.00460	-.00900	-.00170
1.985	-1.110	-.07700	.14420	.00110	-.00060	.03300	-.00950	.00740	-.00480	-.00970	-.00170
1.985	-.110	-.07500	.14360	-.00370	-.00010	-.00270	.00220	.00000	-.00460	-.00970	-.00170
1.985	.900	-.07600	.14420	-.00310	.00040	-.04300	.01480	-.00700	-.00450	-.00860	-.00180
1.985	1.900	-.07800	.14450	.00050	.00100	-.08170	.02780	-.01510	-.00450	-.00820	-.00170
1.985	2.900	-.07600	.14650	-.00400	.00240	-.15010	.04680	-.02740	-.00410	-.00690	-.00140
1.985	3.920	-.07600	.14720	-.00960	.00360	-.21760	.06740	-.03780	-.00290	-.00570	-.00110
1.985	4.930	-.07600	.14720	-.00960	.00360	-.21760	.06740	-.03780	-.00290	-.00570	-.00110
GRADIENT		.00073	.00013	-.00095	.00059	-.03752	.01185	-.00730	.00006	.00019	.00002

RUN NO. 47/ 0 RN/L = 1.74 GRADIENT INTERVAL = -5.00/ 5.00

MACH	BETA	CN	CAF	CLM	CWBM	CY	CYN	CBL	CABORB	CABTNK	CABSRM
2.171	-4.140	-.04700	.14070	-.01740	.00690	.11390	-.02590	.01620	-.00860	-.01600	-.00350
2.171	-2.140	-.05300	.13940	-.00490	.00110	.05950	-.01180	.01110	-.00940	-.01670	-.00390
2.171	-1.140	-.05100	.13850	-.00770	.00130	.02600	-.00330	.00490	-.00900	-.01760	-.00410
2.171	-.130	-.05200	.13750	-.00440	.00150	-.00720	.00530	-.00090	-.00910	-.01740	-.00400
2.171	.870	-.05200	.13750	-.00440	.00150	-.04020	.01150	-.00540	-.00870	-.01620	-.00380
2.171	1.870	-.05300	.13790	-.00400	.00170	-.07200	.01840	-.01030	-.00910	-.01440	-.00380
2.171	2.880	-.04500	.14000	-.02290	.00230	-.12740	.03210	-.01560	-.00800	-.01650	-.00380
2.171	3.890	-.04700	.14050	-.01830	.00310	-.19420	.04830	-.02620	-.00730	-.01440	-.00350
2.171	4.900	-.04700	.14050	-.01830	.00310	-.19420	.04830	-.02620	-.00730	-.01440	-.00350
GRADIENT		.00017	-.00016	-.00040	-.00040	-.03074	.00730	-.00428	.00008	.00009	-.00002

AMES 97-616 IA2 01 TO S1 PC/PT NOM,SRM A/A=0

(RBJ003) (23 JAN 73)

REFERENCE DATA

SREF = 3155.0000 SQ.FT. XMRP = 66.4167 FT.
 LREF = 50.8000 FT. YMRP = .0000 FT.
 BREF = 73.5000 FT. ZMRP = 4.0000 FT.
 SCALE = .0190

PARAMETRIC DATA

BETA = .000 ELEVON = .000
 AILRON = .000 RUDDER = .000
 PLUMES = 2.000

RUN NO. 13/ 0 RN/L = 2.58 GRADIENT INTERVAL = -5.00/ 5.00

MACH	ALPHA	CN	CAF	CLM	CWM	CY	CYN	CBL	CABORB	CABTNK	CABSRM
1.600	-4.010	-.21400	.16170	-.01290	-.00260	-.00240	.00010	.00100	.00190	.00580	.00190
1.600	-2.100	-.11900	.15800	.00970	-.00430	.00230	.00000	.00110	.00180	.00250	.00140
1.600	-1.030	-.11400	.15450	.00440	-.00180	-.00340	.00170	.00110	.00200	.00170	.00140
1.600	-.040	-.07700	.15200	.00500	-.00050	.00070	.00050	.00010	.00190	.00130	.00140
1.600	.970	-.04200	.15050	.00410	.00110	-.00290	.00130	.00060	.00130	.00120	.00140
1.600	2.000	-.00300	.14830	.00120	.00270	-.00190	.00130	.00030	.00170	.00170	.00150
1.600	3.960	.07900	.14500	-.01490	.00810	.00420	.00240	.00020	.00140	.00140	.00140
1.600	5.970	.14900	.14380	-.01660	.00980	-.00550	.00260	-.00090	.00270	.00080	.00120
1.600	8.020	.22700	.14070	-.01690	.01080	-.01020	.00340	.00050	.00280	.00090	.00100
1.600	10.050	.29000	.13610	-.00350	.01150	-.00840	.00210	-.00200	.00150	-.00100	.00070
	GRADIENT	.03699	-.00214	-.00062	.00142	-.00037	.00027	-.00013	-.00007	-.00047	-.00004

RUN NO. 45/ 0 RN/L = 2.10 GRADIENT INTERVAL = -5.00/ 5.00

MACH	ALPHA	CN	CAF	CLM	CWM	CY	CYN	CBL	CABORB	CABTNK	CABSRM
1.985	-3.650	-.20300	.15670	-.01410	-.00010	-.00760	.00260	-.00050	-.00130	-.00270	-.00040
1.985	-1.870	-.14400	.15180	.00580	-.00210	-.00660	.00230	.00050	-.00160	-.00500	-.00050
1.985	-.610	-.10900	.14910	.00970	-.00160	-.00640	.00310	-.00010	-.00170	-.00550	-.00050
1.985	.360	-.07400	.14740	.00770	-.00010	-.00430	.00250	.00030	-.00190	-.00600	-.00060
1.985	1.290	-.03900	.14580	.00630	.00110	-.00560	.00300	.00020	-.00210	-.00520	-.00040
1.985	2.360	.00100	.14450	.00350	.00340	-.00640	.00290	.00030	-.00220	-.00600	-.00070
1.985	4.350	.07900	.14240	-.00550	.00750	-.00640	.00350	.00000	-.00270	-.00670	-.00070
1.985	6.350	.14600	.14240	-.00730	.01070	-.00800	.00400	-.00110	-.00230	-.00790	-.00110
1.985	8.410	.21100	.14040	.01430	.00940	-.01010	.00370	.00090	-.00100	-.00830	-.00110
1.985	10.410	.30000	.13810	.00580	.01110	-.00990	.00390	.00050	-.00080	-.00780	-.00090
	GRADIENT	.03546	-.00179	.00063	.00105	.00014	.00011	.00004	-.00017	-.00042	-.00004

AMES 97-616 IAS 01 TO S1 FC/PT NOM,SRM A/A=8

(RBJ004) (23 JAN 73)

REFERENCE DATA

SREF = 3155.0000 SQ.FT. XMRP = 86.4167 FT.
 LREF = 30.8000 FT. YMRP = .0000 FT.
 BREF = 73.5000 FT. ZMRP = 4.0000 FT.
 SCALE = .0190

PARAMETRIC DATA

ALPHA = .000 ELEVON = .000
 AILRON = .000 RUDDER = .000
 PLUMES = 2.000

RUN NO. 11/ 0 RN/L = 2.53 GRADIENT INTERVAL = -5.00/ 5.00

MACH	BETA	CN	CAF	CLM	CWM	CY	CYN	CBL	CACORB	CABTNK	CABSRM
1.600	-4.170	-.08800	.15400	.01410	-.00500	.16250	-.05020	.03890	.00240	.00330	.00200
1.600	-2.160	-.08300	.15350	.00750	-.00250	.08310	-.02590	.02040	.00210	.00250	.00170
1.600	-1.150	-.08300	.15290	.00350	-.00180	.03940	-.01260	.01110	.00200	.00250	.00170
1.600	-.150	-.07800	.15270	.00320	-.00070	-.00140	.00040	.00030	.00210	.00190	.00160
1.600	.860	-.08300	.15350	.00620	-.00010	-.04180	.01300	-.00940	.00170	.00270	.00160
1.600	1.870	-.08400	.15360	.00730	.00070	-.08340	.02670	-.01950	.00180	.00270	.00160
1.600	3.890	-.09000	.15370	.01200	.00200	-.16130	.05020	-.03830	.00210	.00300	.00170
1.600	5.900	-.09300	.15350	.01150	.00360	-.24770	.07790	-.05650	.00220	.00480	.00200
	GRADIENT	-.00024	-.00001	-.00019	.00085	-.04040	.01258	-.00967	-.00005	-.00001	-.00004

RUN NO. 46/ 0 RN/L = 2.09 GRADIENT INTERVAL = -5.00/ 5.00

MACH	BETA	CN	CAF	CLM	CWM	CY	CYN	CBL	CACORB	CABTNK	CABSRM
1.985	-4.120	-.08100	.15000	.01250	-.00310	.15520	-.05440	.03400	-.00130	-.00310	.00010
1.985	-2.110	-.08000	.14840	.00980	-.00170	.07630	-.02680	.01800	-.00120	-.00460	-.00020
1.985	-1.110	-.07900	.14830	.00880	-.00130	.03710	-.01270	.00950	-.00140	-.00470	-.00030
1.985	-.100	-.08000	.14700	.00860	-.00050	-.00240	.00220	.00040	-.00150	-.00500	-.00040
1.985	.900	-.08000	.14810	.00780	.00020	-.04620	.01800	-.00850	-.00200	-.00550	-.00050
1.985	1.900	-.08200	.14840	.00880	.00120	-.08580	.03180	-.01730	-.00200	-.00500	-.00040
1.985	3.920	-.08200	.14940	.00940	.00260	-.16490	.05940	-.03420	-.00200	-.00450	-.00040
1.985	5.930	-.08700	.15140	.01290	.00360	-.23960	.08220	-.04610	-.00050	-.00220	.00010
	GRADIENT	-.00021	-.00006	-.00036	.00071	-.04001	.01429	-.00857	-.00012	-.00017	-.00006

AMES 97-616 1A2 01 TO S1 PC/PT NOM

(DBJ005) (23 OCT 73)

REFERENCE DATA

SREF = 3155.0000 SQ.FT. XMRP = 86.4167 FT.
 LREF = 50.8000 FT. YMRP = .0000 FT.
 BREF = 73.5000 FT. ZMRP = 4.0000 FT.
 SCALE = .0190

PARAMETRIC DATA

BETA = .000 ELEVON = .000
 AILRON = .000 RUDDER = .000
 PLUMES = 3.000

RUN NO. 12/ 0 RN/L = 2.54 GRADIENT INTERVAL = -5.00/ 5.00

MACH	ALPHA	CN	CAF	CLM	CWM	CY	CYN	CBL	CABORB	CABTNK	CABSRM
1.600	-3.980	-.29300	.18250	.09900	-.01350	-.00240	.00090	.00030	.01210	.04250	.01100
1.600	-1.970	-.20200	.17680	.08130	-.00840	-.00150	.00130	.00100	.01250	.04260	.01090
1.600	-.970	-.16000	.17370	.07490	-.00590	-.00160	.00040	.00160	.01270	.04260	.01080
1.600	.020	-.10900	.17120	.06230	-.00400	-.00010	.00050	.00130	.01250	.04200	.01060
1.600	1.050	-.06600	.16780	.05240	-.00100	-.00160	.00020	.00050	.01270	.04140	.01050
1.600	2.040	-.02400	.16510	.04210	.00170	-.00160	.00110	.00090	.01220	.04030	.01020
1.600	3.980	.06000	.16020	.01840	.00720	-.00300	.00200	-.00040	.01210	.03870	.01000
1.600	6.030	.15100	.15580	-.00850	.01200	-.00600	.00220	-.00060	.01200	.03860	.00990
1.600	8.010	.24400	.15240	-.03340	.01700	-.01030	.00240	-.00080	.01230	.03830	.00980
1.600	10.040	.33600	.14950	-.05510	.02070	-.01160	.00280	-.00160	.01150	.03780	.00960
	GRADIENT	.04446	-.00283	-.01010	.00258	-.00005	.00009	-.00010	-.00001	-.00003	-.00014

RUN NO. 42/ 0 RN/L = 2.26 GRADIENT INTERVAL = -5.00/ 5.00

MACH	ALPHA	CN	CAF	CLM	CWM	CY	CYN	CBL	CABORB	CABTNK	CABSRM
1.985	-3.630	-.26100	.17420	.07490	-.00880	-.00580	.00200	.00010	.00690	.03450	.00860
1.985	-1.620	-.17300	.16790	.05870	-.00590	-.00410	.00190	.00030	.00730	.03260	.00830
1.985	-.650	-.13300	.16480	.05150	-.00420	-.00450	.00180	.00040	.00750	.03220	.00820
1.985	.340	-.09300	.16160	.04260	-.00210	-.00310	.00150	.00040	.00760	.03150	.00810
1.985	1.370	-.05100	.15930	.03390	.00040	-.00370	.00160	.00010	.00760	.03090	.00790
1.985	2.350	-.01100	.15750	.02700	.00290	-.00360	.00150	.00020	.00730	.02980	.00760
1.985	4.370	.07100	.15480	.01470	.00770	-.00410	.00230	.00010	.00690	.02770	.00710
1.985	6.320	.14800	.15160	.00570	.01080	-.00640	.00270	-.00030	.00670	.02750	.00700
1.985	8.370	.23000	.14890	-.00220	.01380	-.00690	.00260	-.00050	.00660	.02790	.00710
1.985	10.350	.31900	.14600	-.01450	.01630	-.00780	.00270	-.00100	.00720	.02780	.00710
	GRADIENT	.04132	-.00247	-.00767	.00210	.00020	.00001	-.00001	.00000	-.00081	-.00002

AMES 97-816 IA2 01 TO 51 PC/PT NOM

(DBJ006) (25 OCT 73)

REFERENCE DATA

SREF = 3155.0000 SQ.FT. XMRP = 86.4167 FT.
 LREF = 50.8000 FT. YMRP = .0000 FT.
 BREF = 73.5000 FT. ZMRP = 4.0000 FT.
 SCALE = .9190

PARAMETRIC DATA

ALPHA = .000 ELEVON = .000
 AILRON = .000 RUDDER = .000
 PLUMES = 3.000

RUN NO. 10/ 0 RN/L = 2.55 GRADIENT INTERVAL = -5.00/ 5.00

MACH	BETA	CN	CAF	CLM	CMBM	CY	CYN	CBL	CABORB	CABTNK	CABSRM
1.600	-4.130	-.12100	.17110	.06410	-.00830	.16320	-.04970	.03930	.01210	.04150	.01080
1.600	-2.160	-.11900	.17190	.06580	-.00620	.08280	-.02560	.02130	.01240	.04190	.01070
1.600	-1.150	-.11900	.17180	.06550	-.00510	.03980	-.01210	.01170	.01220	.04190	.01060
1.600	-.150	-.11800	.17130	.06390	-.00420	.00060	.00050	.00100	.01200	.04170	.01050
1.600	.860	-.11700	.17230	.06440	-.00290	-.03870	.01190	-.00950	.01210	.04120	.01050
1.600	1.870	-.11800	.17220	.06580	-.00200	-.08070	.02490	-.01930	.01250	.04140	.01060
1.600	3.890	-.12100	.17150	.06520	.00020	-.16170	.05020	-.03800	.01310	.04190	.01080
1.600	5.900	-.12200	.17030	.06100	.00230	-.24740	.07780	-.05780	.01320	.04150	.01060
	GRADIENT	.00009	.00006	.00008	.00106	-.04045	.01245	-.00977	.00010	-.00000	-.00001

RUN NO. 41/ 0 RN/L = 2.25 GRADIENT INTERVAL = -5.00/ 5.00

MACH	BETA	CN	CAF	CLM	CMBM	CY	CYN	CBL	CABORB	CABTNK	CABSRM
1.985	-4.120	-.10200	.16310	.04430	-.00570	.15960	-.05600	.03440	.00740	.03130	.00790
1.985	-2.110	-.10200	.16320	.04550	-.00380	.07840	-.02690	.01790	.00730	.03070	.00790
1.985	-1.110	-.10200	.16230	.04580	-.00330	.03870	-.01320	.00940	.00740	.03160	.00810
1.985	-.100	-.10100	.16190	.04520	-.00240	-.00060	.00060	.00090	.00770	.03190	.00810
1.985	.900	-.10200	.16160	.04610	-.00150	-.04180	.01430	-.00760	.00790	.03210	.00820
1.985	1.910	-.10200	.16230	.04600	-.00040	-.08460	.02990	-.01730	.00810	.03200	.00820
1.985	3.920	-.10400	.16270	.04700	.00130	-.16470	.05820	-.03430	.00860	.03180	.00810
1.985	5.940	-.10600	.16330	.04760	.00300	-.24360	.08500	-.04920	.00870	.03070	.00780
	GRADIENT	-.00019	-.00010	.00029	.00087	-.04036	.01416	-.00858	.00016	.00012	.00004

AMES 97-616 IAS 01 TO S1 SRM A/A=12, ORB NOM

(RBJ007) (23 JAN 73)

REFERENCE DATA

SREF = 3155.0000 SQ.FT. XMRP = 86.4167 FT.
 LREF = 50.8000 FT. YMRP = .0000 FT.
 BREF = 73.5000 FT. ZMRP = 4.0000 FT.
 SCALE = .0190

PARAMETRIC DATA

BETA = .000 ELEVON = .000
 AILRON = .000 RUDDER = .000
 PLUMES = 5.000

RUN NO. 8/ 0 RN/L = 2.55 GRADIENT INTERVAL = -5.00/ 5.00

MACH	ALPHA	CN	CAF	CLM	CWBM	CY	CYN	CBL	CABCRB	CABTNK	CABSRM
1.600	-4.060	-.24200	.17170	.02990	-.00880	.00280	-.00130	.00030	.00500	.02090	.00540
1.600	-2.030	-.16700	.16590	.03740	-.00710	-.00060	.00100	.00080	.00490	.01970	.00520
1.600	-1.020	-.12700	.16440	.03910	-.00530	-.00070	.00070	.00120	.00580	.02260	.00580
1.600	-.030	-.08800	.16070	.03210	-.00290	.00170	.00000	.00100	.00550	.02020	.00530
1.600	.990	-.04700	.15800	.02280	-.00050	.00220	-.00030	.00080	.00550	.01930	.00510
1.600	1.990	-.00600	.15830	.01620	.00180	-.00100	.00030	.00020	.00650	.01940	.00500
1.600	3.920	.07900	.15330	-.00550	.00710	-.00050	.00160	.00010	.00580	.01680	.00440
1.600	5.970	.16400	.14900	-.02840	.01240	-.00420	.00200	-.00050	.00620	.01600	.00410
1.600	7.970	.25900	.14480	-.05360	.01750	-.00800	.00230	-.00070	.00660	.01410	.00360
1.600	9.980	.35100	.14220	-.07550	.02090	-.00980	.00260	-.00140	.00590	.01230	.00310
	GRADIENT	.04024	-.00227	-.00475	.00205	-.00026	.00022	-.00006	.00015	-.00048	-.00012

RUN NO. 37/ 0 RN/L = 2.08 GRADIENT INTERVAL = -5.00/ 5.00

MACH	ALPHA	CN	CAF	CLM	CWBM	CY	CYN	CBL	CABCRB	CABTNK	CABSRM
1.985	-3.700	-.24100	.16260	.03420	-.00800	-.00410	.00060	.00290	.00050	.01020	.00280
1.985	-1.680	-.16200	.15770	.03390	-.00550	-.00340	.00140	.00020	-.00010	.01010	.00260
1.985	-.630	-.12200	.15480	.02800	-.00390	-.00440	.00170	.00020	-.00040	.00950	.00250
1.985	.330	-.08400	.15250	.02140	-.00180	-.00350	.00170	.00050	-.00060	.00840	.00230
1.985	1.340	-.04400	.15070	.01570	.00040	-.00380	.00190	.00030	-.00090	.00780	.00200
1.985	2.390	-.00400	.15090	.01360	.00310	-.00380	.00180	.00020	-.00010	.00800	.00200
1.985	4.370	.07600	.14820	.00250	.00760	-.00440	.00250	-.00020	-.00020	.00610	.00170
1.985	6.350	.15600	.14570	-.00810	.01100	-.00700	.00310	-.00040	-.00010	.00270	.00090
1.985	8.370	.23800	.14350	-.01480	.01370	-.00770	.00340	-.00060	.00050	.00120	.00050
1.985	10.360	.32600	.13910	-.02900	.01640	-.00780	.00300	-.00070	.00090	-.00060	.00000
	GRADIENT	.03921	-.00178	-.00424	.00198	-.00003	.00020	-.00029	-.00008	-.00053	-.00014

AMES 97-616 IA2 01 TO S1 SRM A/A=12,CR3 NOM

(RBJ008) (23 JAN 73)

REFERENCE DATA

SREF = 3155.0000 SQ.FT. XMRP = 86.4167 FT.
 LREF = 30.8000 FT. YMRP = .0000 FT.
 BREF = 73.5000 FT. ZMRP = 4.0000 FT.
 SCALE = .0190

PARAMETRIC DATA

ALPHA = .000 ELEVON = .000
 AILRON = .000 RUDDER = .000
 PLUMES = 5.000

RUN NO. 9/ 0 RN/L = 2.53 GRADIENT INTERVAL = -5.00/ 5.00

MACH	BETA	CN	CAF	CLM	CWM	CY	CYN	CBL	CABCRB	CABTNK	CABSRM
1.600	-4.170	-.09800	.16120	.03670	-.00770	.16390	-.04860	.03900	.00500	.02110	.00560
1.600	-2.170	-.09700	.16160	.03310	-.00540	.08210	-.02470	.01980	.00450	.01890	.00510
1.600	-1.150	-.09700	.16070	.03220	-.00450	.04130	-.01260	.01110	.00460	.01910	.00510
1.600	-.150	-.09600	.16070	.03070	-.00340	.00170	-.00030	.00090	.00430	.01820	.00490
1.600	.870	-.09400	.16050	.03030	-.00240	-.03820	.01140	-.00890	.00420	.01780	.00480
1.600	1.880	-.10200	.16140	.03440	-.00140	-.08210	.02460	-.01780	.00470	.01890	.00510
1.600	3.890	-.10000	.16030	.03300	.00060	-.16030	.04800	-.03700	.00450	.01750	.00480
1.600	5.890	-.10200	.15900	.03030	.00250	-.24590	.07520	-.05600	.00470	.01820	.00490
	GRADIENT	-.00035	-.00010	-.00033	.00102	-.04024	.01202	-.00942	-.00005	-.00037	-.00008

RUN NO. 36/ 0 RN/L = 2.05 GRADIENT INTERVAL = -5.00/ 5.00

MACH	BETA	CN	CAF	CLM	CWM	CY	CYN	CBL	CABCRB	CABTNK	CABSRM
1.985	-4.130	-.08700	.15320	.01950	-.00460	.15480	-.05190	.03250	-.00080	.00700	.00170
1.985	-2.120	-.08900	.15310	.02100	-.00340	.07610	-.02470	.01660	-.00110	.00760	.00190
1.985	-1.110	-.08900	.15280	.02130	-.00280	.03870	-.01220	.00860	-.00080	.00800	.00220
1.985	-.100	-.08800	.15310	.02220	-.00220	-.00150	.00110	.00060	-.00060	.00860	.00230
1.985	.900	-.09000	.15280	.02240	-.00120	-.04200	.01400	-.00770	-.00060	.00820	.00230
1.985	1.900	-.09000	.15350	.02310	-.00050	-.08170	.02770	-.01620	-.00060	.00810	.00230
1.985	3.920	-.09300	.15420	.02520	.00120	-.16100	.05510	-.03230	.00020	.00960	.00250
1.985	5.930	-.09500	.15550	.02660	.00300	-.23900	.08080	-.04680	.00070	.00980	.00250
	GRADIENT	-.00064	.00011	.00067	.00072	-.03928	.01323	-.00809	.00012	.00027	.00010

AMES 97-616 IAZ 01 TO S1 PC/PT=1.3 NOMINAL

(RBJ009) (23 JAN 73)

REFERENCE DATA

SREF = 3155.0000 SQ.FT. XMRP = 86.4167 FT.
 LREF = 50.8000 FT. YMRP = .0000 FT.
 BREF = 73.3000 FT. ZMRP = 4.0000 FT.
 SCALE = .0190

PARAMETRIC DATA

BETA = .000 ELEVON = .000
 AILRON = .000 RUDDER = .000
 PLUMES = 5.000

RUN NO. 14/ 0 RN/L = 1.98 GRADIENT INTERVAL = -5.00/ 5.00

MACH	ALPHA	CN	CAF	CLM	CWB	CY	CYN	CBL	CABORB	CABTNK	CABSRM
1.600	-4.060	-.21900	.15680	-.02130	.00000	-.00520	.00190	.00070	-.00120	-.00330	.00000
1.600	-2.110	-.15500	.15200	-.00290	-.00250	-.00560	.00360	.00040	-.00220	-.00700	-.00110
1.600	-1.060	-.11800	.14870	-.00030	-.00140	-.00120	.00240	.00030	-.00200	-.00780	-.00130
1.600	-.080	-.07800	.14570	-.00210	-.00010	-.00410	.00310	.00010	-.00270	-.01030	-.00180
1.600	.890	-.04400	.14340	-.00450	.00180	-.00310	.00270	.00020	-.00270	-.01060	-.00180
1.600	1.930	-.00500	.13990	-.00850	.00310	-.00500	.00310	.00010	-.00330	-.01140	-.00210
1.600	3.900	.07200	.13660	-.01980	.00770	-.00630	.00350	-.00010	-.00310	-.01020	-.00190
1.600	5.900	.13900	.13160	-.02190	.00920	-.00970	.00510	.00010	-.00370	-.01190	-.00220
1.600	7.930	.20200	.12850	-.00860	.00980	-.01250	.00510	-.00070	-.00370	-.01290	-.00210
1.600	9.960	.26800	.12550	.00570	.01000	-.01270	.00440	-.00090	-.00560	-.01250	-.00200
GRADIENT		.03873	-.00264	-.00023	.00108	-.00012	.00014	-.00009	-.00025	-.00094	-.00024

RUN NO. 38/ 0 RN/L = 1.65 GRADIENT INTERVAL = -5.00/ 5.00

MACH	ALPHA	CN	CAF	CLM	CWB	CY	CYN	CBL	CABORB	CABTNK	CABSRM
1.985	-3.730	-.21200	.15030	-.01970	-.00060	-.00890	.00390	.00060	-.00730	-.01240	-.00270
1.985	-1.740	-.13800	.14480	-.01540	-.00010	-.00830	.00510	-.00060	-.00820	-.01550	-.00350
1.985	-.710	-.10400	.14130	-.01180	.00040	-.00950	.00560	-.00110	-.00820	-.01750	-.00380
1.985	.300	-.06600	.13920	-.01230	.00080	-.00810	.00470	.00030	-.00790	-.01740	-.00370
1.985	1.310	-.03200	.13720	-.01200	.00210	-.00740	.00470	.00020	-.00790	-.01750	-.00370
1.985	2.290	.00300	.13660	-.01180	.00320	-.00870	.00530	.00060	-.00830	-.01930	-.00410
1.985	4.320	.07700	.13230	-.01090	.00680	-.01060	.00630	-.00070	-.00880	-.02010	-.00430
1.985	6.320	.13400	.12920	.00440	.00810	-.01140	.00670	-.00200	-.00980	-.02130	-.00480
1.985	8.330	.19100	.12750	.02850	.00760	-.01060	.00440	-.00240	-.01060	-.02160	-.00460
1.985	10.360	.27200	.12440	.02630	.00900	-.01010	.00440	-.00240	-.01060	-.02150	-.00470
GRADIENT		.03571	-.00219	.00100	.00090	-.00013	.00021	-.00004	-.00014	-.00091	-.00018

REFERENCE DATA

SREF = 3155.0000 SQ.FT. XMRP = 86.4167 FT.
 LREF = 50.8000 FT. YMRP = .0000 FT.
 BREF = 73.5000 FT. ZMRP = 4.0000 FT.
 SCALE = .0190

PARAMETRIC DATA

ALPHA = .000 ELEVON = .000
 AILRON = .000 RUDDER = .000
 PLUMES = 5.000

RUN NO. 15/ 0 RN/L = 1.99 GRADIENT INTERVAL = -5.00/ 5.00

MACH	BETA	CN	CAF	CLM	CWBM	CY	CYN	CBL	CABORB	CABTNK	CABSRM
1.600	-4.170	-.09800	.14650	.00680	-.00360	.15590	-.04110	.03550	-.00270	-.00800	-.00080
1.600	-3.170	-.09000	.14660	.00410	-.00280	.11720	-.03010	.02690	-.00280	-.00950	-.00140
1.600	-2.160	-.09400	.14680	.00190	-.00190	.07840	-.01950	.01840	-.00240	-.00840	-.00150
1.600	-1.150	-.08800	.14650	.00130	-.00110	.03620	-.00820	.00980	-.00210	-.00800	-.00140
1.600	-.140	-.09400	.14730	.00070	-.00060	-.00230	.00230	.00050	-.00180	-.00830	-.00130
1.600	.870	-.09400	.14710	.00190	.00030	-.04170	.01250	-.00770	-.00180	-.00680	-.00120
1.600	1.870	-.09200	.14830	.00350	.00110	-.07830	.02270	-.01640	-.00150	-.00710	-.00130
1.600	3.880	-.09700	.14780	.00730	.00210	-.15710	.04440	-.03250	-.00200	-.00780	-.00130
1.600	5.890	-.09900	.14670	.00350	.00330	-.23720	.06740	-.04950	-.00210	-.00660	-.00120
	GRADIENT	-.00016	.00021	.00009	.00072	-.03891	.01057	-.00850	.00014	.00018	-.00002

RUN NO. 39/ 0 RN/L = 1.65 GRADIENT INTERVAL = -5.00/ 5.00

MACH	BETA	CN	CAF	CLM	CWBM	CY	CYN	CBL	CABORB	CABTNK	CABSRM
1.985	-4.110	-.07200	.14310	-.01360	.00290	.12940	-.03400	.02410	-.00790	-.01500	-.00350
1.985	-2.110	-.07400	.13950	-.00820	-.00030	.06500	-.01640	.01400	-.00830	-.01680	-.00390
1.985	-1.110	-.07200	.13950	-.01130	.00020	.02740	-.00540	.00740	-.00830	-.01830	-.00400
1.985	-.110	-.07200	.13910	-.01180	.00070	-.00780	.00490	.00040	-.00830	-.01830	-.00390
1.985	.900	-.07500	.13950	-.01080	.00130	-.04270	.01390	-.00680	-.00800	-.01660	-.00390
1.985	1.910	-.07600	.13940	-.00830	.00180	-.08010	.02400	-.01410	-.00810	-.01650	-.00400
1.985	3.910	-.06600	.14260	-.02750	.00240	-.13500	.03750	-.01940	-.00670	-.01570	-.00350
1.985	5.920	-.06900	.14390	-.02490	.00350	-.20710	.05720	-.03120	-.00630	-.01470	-.00330
	GRADIENT	.00040	-.00003	-.00131	.00008	-.03366	.00916	-.00580	.00013	-.00001	-.00000

AMES 97-616 IA2 01 TO S1 PC/PT=NOM,SRM A/A=8

(RBJ011) (23 JAN 73)

REFERENCE DATA

SREF = 3155.0000 SQ.FT. XMRP = 86.4167 FT.
 LREF = 50.8000 FT. YMRP = .0000 FT.
 BREF = 73.5000 FT. ZMRP = 4.0000 FT.
 SCALE = .0190

PARAMETRIC DATA

BETA = .000 ELEVON = 10.000
 AILRON = .000 RUDDER = 10.000
 PLUMES = 5.000

RUN NO. 16/ 0 RN/L = 2.60 GRADIENT INTERVAL = -5.00/ 5.00

MACH	ALPHA	CN	CAF	CLM	CWBM	CY	CYN	CBL	CABORB	CABTNK	CABSRM
1.600	-4.040	-.20000	.16310	-.01520	-.00430	.00840	-.01050	.00390	.00020	.00270	.00130
1.600	-2.110	-.14200	.15940	.00080	-.00420	.01260	-.01010	.00580	.00140	.00160	.00070
1.600	-1.080	-.10100	.15600	-.00280	-.00190	.01070	-.01010	.00600	.00130	.00000	.00040
1.600	-.070	-.05900	.15320	-.00730	-.00010	.01110	-.01020	.00630	.00130	-.00120	.00030
1.600	.940	-.01700	.15030	-.01490	.00220	.01360	-.01060	.00480	.00160	-.00170	.00020
1.600	1.920	.02100	.14800	-.02110	.00460	.01070	-.00920	.00480	.00170	-.00150	.00020
1.600	3.920	.10500	.14480	-.03670	.00970	.00800	-.00760	.00400	.00250	-.00130	.00030
1.600	5.940	.18900	.14180	-.06170	.01450	.00210	-.00500	.00340	.00190	-.00330	-.00030
1.600	7.920	.25600	.14230	-.05520	.01510	-.00140	-.00530	.00320	.00140	-.00550	-.00090
1.600	9.930	.32700	.13900	-.04500	.01560	.00090	-.00530	.00190	.00050	-.00560	-.00080
GRADIENT		.03890	-.00262	-.00359	.00186	-.00006	.00031	-.00026	.00024	-.00057	-.00012

RUN NO. 48/ 0 RN/L = 2.08 GRADIENT INTERVAL = -5.00/ 5.00

MACH	ALPHA	CN	CAF	CLM	CWBM	CY	CYN	CBL	CABORB	CABTNK	CABSRM
1.985	-3.730	-.20700	.15310	.00170	-.00310	-.00030	-.00320	.00270	-.00610	-.01030	-.00240
1.985	-1.710	-.13700	.14660	.00140	-.00220	.00160	-.00270	.00220	-.00610	-.01010	-.00220
1.985	-.730	-.10400	.14420	.00190	-.00140	.00040	-.00240	.00240	-.00630	-.01100	-.00240
1.985	.300	-.06500	.14120	-.00250	-.00010	.00160	-.00260	.00250	-.00630	-.01120	-.00250
1.985	1.290	-.03000	.13960	-.00590	.00170	.00120	-.00210	.00230	-.00660	-.01220	-.00260
1.985	2.260	.00900	.13740	-.01050	.00380	.00090	-.00170	.00150	-.00670	-.01370	-.00300
1.985	4.290	.08600	.13580	-.01700	.00780	.00140	-.00180	.00090	-.00680	-.01470	-.00330
1.985	6.270	.15700	.13450	-.01700	.01050	-.00190	.00060	-.00050	-.00730	-.01660	-.00380
1.985	8.320	.22600	.13310	-.00750	.01100	-.00310	.00010	.00000	-.00720	-.01680	-.00370
1.985	10.310	.30800	.13330	-.01090	.01250	-.00190	-.00150	.00050	-.00640	-.01690	-.00370
GRADIENT		.03658	-.00219	-.00253	.00140	.00015	.00019	-.00021	-.00010	-.00062	-.00013

RUN NO. 58/ 0 RN/L = 1.72 GRADIENT INTERVAL = -5.00/ 5.00

MACH	ALPHA	CN	CAF	CLM	CWBM	CY	CYN	CBL	CABORB	CABTNK	CABSRM
2.171	-3.470	-.20400	.14940	.00610	-.00230	-.00200	.00060	.00030	-.00850	-.01380	-.00350
2.171	-1.490	-.12500	.14230	.00180	-.00100	-.00270	.00210	-.00050	-.00900	-.01620	-.00380
2.171	-.470	-.08400	.13920	-.00050	.00000	-.00350	.00260	-.00050	-.00910	-.01660	-.00390
2.171	.530	-.04600	.13520	-.00490	.00130	-.00400	.00370	-.00110	-.00920	-.01640	-.00390
2.171	1.540	-.01000	.13280	-.00960	.00260	-.00320	.00370	-.00140	-.00930	-.01740	-.00420
2.171	2.540	.02800	.13140	-.01590	.00390	-.00290	.00260	-.00100	-.00960	-.01830	-.00450
2.171	4.520	.09700	.12810	-.02080	.00690	-.00360	.00340	-.00190	-.01020	-.02060	-.00510
2.171	6.540	.15500	.12500	-.00880	.00830	.00190	.00080	-.00150	-.01070	-.02020	-.00500
2.171	8.540	.21700	.12300	.00170	.00970	-.00660	.00350	-.00280	-.01070	-.02130	-.00500
2.171	10.560	.30100	.12370	.00040	.01110	-.00700	.00330	-.00290	-.01090	-.02210	-.00510
GRADIENT		.03769	-.00270	-.00362	.00117	-.00015	.00032	-.00025	-.00019	-.00077	-.00019

AMES 97-816 IA2 01 TO S1 PC/PT=NOM,SRM A/A=8

(RBJ012) (23 JAN 73)

REFERENCE DATA

SREF = 3155.0000 SQ.FT. XMRP = 86.4167 FT.
 LREF = 50.8000 FT. YMRP = .0000 FT.
 BRFP = 73.5000 FT. ZMRP = 4.0000 FT.
 SCALE = .0190

PARAMETRIC DATA

ALPHA = .000 ELEVON = 10.000
 AILRON = .000 RUDDER = 10.000
 PLUMES = 5.000

RUN NO. 17/ 0 RN/L = 2.55 GRADIENT INTERVAL = -5.00/ 5.00

MACH	BETA	CN	CAF	CLM	CWBM	CY	CYN	CBL	CABORB	CABTNK	CABSRM
1.600	-4.180	-.06500	.15480	-.00930	-.00330	.17920	-.06140	.04370	.00150	.00110	.00130
1.600	-2.160	-.06800	.15370	-.00690	-.00180	.09880	-.03680	.02480	.00130	.00090	.00090
1.600	-1.150	-.07000	.15350	-.00710	-.00140	.05530	-.02410	.01600	.00110	.00060	.00070
1.600	-.140	-.06900	.15300	-.00730	-.00040	.01400	-.01000	.00530	.00080	-.00040	.00040
1.600	.870	-.06900	.15410	-.00680	.00030	-.02740	.00240	-.00420	.00100	.00050	.00040
1.600	1.870	-.06900	.15520	-.00530	.00110	-.06810	.01480	-.01340	.00120	.00010	.00040
1.600	3.890	-.07200	.15580	-.00680	.00300	-.14710	.03820	-.03100	.00160	.00080	.00080
1.600	5.900	-.06900	.15540	-.01200	.00510	-.22960	.06220	-.04830	.00100	.00210	.00090
	GRADIENT	-.00068	.00018	.00032	.00077	-.04064	.01247	-.00933	.00000	-.00007	-.00008

RUN NO. 49/ 0 RN/L = 2.08 GRADIENT INTERVAL = -5.00/ 5.00

MACH	BETA	CN	CAF	CLM	CWBM	CY	CYN	CBL	CABORB	CABTNK	CABSRM
1.985	-4.110	-.07200	.14430	-.00520	.00110	.15020	-.05070	.03180	-.00570	-.01060	-.00230
1.985	-2.110	-.07600	.14190	.00030	-.00130	.08260	-.03050	.01890	-.00610	-.01130	-.00250
1.985	-1.110	-.07600	.14240	.00090	-.00090	.04390	-.01710	.01130	-.00600	-.01120	-.00250
1.985	-.110	-.07500	.14200	.00000	-.00030	.00390	-.00320	.00290	-.00580	-.01040	-.00230
1.985	.900	-.07600	.14240	.00080	.00030	-.03490	.00960	-.00540	-.00530	-.00950	-.00220
1.985	1.910	-.07800	.14320	.00280	.00120	-.07540	.02300	-.01420	-.00490	-.00940	-.00220
1.985	3.920	-.07400	.14580	-.00390	.00230	-.14110	.04000	-.02500	-.00440	-.00790	-.00170
1.985	5.930	-.07700	.14730	-.00380	.00410	-.20640	.05740	-.03520	-.00340	-.00630	-.00130
	GRADIENT	-.00028	.00020	.00024	.00026	-.03699	.01177	-.00735	.00020	.00039	.00008

RUN NO. 59/ 0 RN/L = 1.73 GRADIENT INTERVAL = -5.00/ 5.00

MACH	BETA	CN	CAF	CLM	CWBM	CY	CYN	CBL	CABORB	CABTNK	CABSRM
2.171	-4.140	-.05100	.13890	-.01010	.00450	.12540	-.03540	.02270	-.00870	-.01480	-.00330
2.171	-2.140	-.05200	.13660	-.00790	.00150	.06710	-.01900	.01220	-.00970	-.01610	-.00400
2.171	-1.140	-.05500	.13550	-.00520	.00090	.03260	-.00850	.00610	-.00930	-.01680	-.00410
2.171	-.130	-.05500	.13590	-.00400	.00110	-.00370	.00350	-.00090	-.00940	-.01660	-.00410
2.171	.870	-.05700	.13740	-.00120	.00130	-.03800	.01220	-.00660	-.00920	-.01550	-.00400
2.171	1.880	-.05600	.13760	-.00460	.00140	-.06800	.01750	-.01100	-.00940	-.01430	-.00390
2.171	3.880	-.05400	.14010	-.00880	.00220	-.12100	.02910	-.01790	-.00830	-.01470	-.00360
2.171	5.900	-.05500	.14120	-.00760	.00340	-.18420	.03950	-.02560	-.00770	-.01330	-.00330
	GRADIENT	-.00052	.00021	.00037	-.00021	-.03148	.00835	-.00526	.00005	.00013	-.00002

AMES 97-616 IA2 01 TO S1 PC/PT=NOM,SRM A/A=8

(RBJ013) (23 JAN 73)

REFERENCE DATA

SREF = 3155.0000 SQ.FT. XMRP = 86.4167 FT.
 LREF = 50.8000 FT. YMRP = .0000 FT.
 DREF = 73.5000 FT. ZMRP = 4.0000 FT.
 SCALE = .0190

PARAMETRIC DATA

BETA = .000 ELEVON = 10.000
 AILRON = .000 RUDDER = 10.000
 PLUMES = 2.000

RUN NO. 21/ 0 RN/L = 2.55 GRADIENT INTERVAL = -5.00/ 5.00

MACH	ALPHA	CN	CAF	CLM	CWBM	CY	CYN	CBL	CABORB	CABTNK	CABSRM
1.600	-4.070	-.20900	.16650	-.01110	-.00430	.01420	-.01420	.00730	.00200	.00340	.00150
1.600	-2.030	-.14000	.15930	.00360	-.00400	.01060	-.01220	.00810	.00190	.00230	.00100
1.600	-1.000	-.09900	.15650	.00100	-.00190	.01290	-.01290	.00740	.00170	.00160	.00080
1.600	.010	-.06000	.15340	-.00360	.00000	.01210	-.01250	.00710	.00150	.00000	.00070
1.600	.970	-.02300	.15130	-.01000	.00200	.01280	-.01280	.00660	.00160	-.00030	.00080
1.600	2.020	.01900	.14910	-.01690	.00410	.00940	-.01120	.00580	.00160	.00000	.00090
1.600	4.000	.10300	.14670	-.03610	.00940	.01060	-.01040	.00620	.00190	.00050	.00100
1.600	6.000	.18900	.14730	-.05740	.01370	.00570	-.00930	.00540	.00290	-.00180	.00040
1.600	8.010	.25800	.14470	-.05430	.01430	.00380	-.00930	.00520	.00330	-.00270	.00000
1.600	10.040	.33000	.13980	-.04440	.01470	.00230	-.00880	.00380	.00160	-.00490	-.00050
1.600	GRADIENT	.03876	-.00248	-.00366	.00177	-.00040	.00041	-.00023	-.00003	-.00043	-.00005

RUN NO. 57/ 0 RN/L = 2.07 GRADIENT INTERVAL = -5.00/ 5.00

MACH	ALPHA	CN	CAF	CLM	CWBM	CY	CYN	CBL	CABORB	CABTNK	CABSRM
1.985	-3.640	-.21500	.15950	.00640	-.00330	.00710	-.01020	.00580	-.00120	-.00320	-.00070
1.985	-1.650	-.14400	.15320	.01500	-.00320	.00740	-.00930	.00560	-.00180	-.00380	-.00060
1.985	-.630	-.10700	.14930	.01150	-.00200	.00740	-.00920	.00580	-.00180	-.00480	-.00070
1.985	.360	-.07000	.14730	.00740	-.00020	.00740	-.00900	.00550	-.00210	-.00540	-.00070
1.985	1.350	-.03200	.14550	.00420	.00170	.00720	-.00850	.00540	-.00230	-.00590	-.00070
1.985	2.350	.00700	.14350	.00010	.00380	.00720	-.00840	.00500	-.00240	-.00790	-.00120
1.985	4.340	.08300	.14180	-.00810	.00780	.00620	-.00770	.00450	-.00250	-.00790	-.00100
1.985	6.350	.15800	.14370	-.00970	.01000	.00430	-.00710	.00410	-.00190	-.00880	-.00150
1.985	8.370	.23300	.14290	-.00810	.01220	.00210	-.00650	.00370	-.00060	-.01050	-.00170
1.985	10.370	.31900	.14090	-.01790	.01390	.00050	-.00610	.00380	-.00030	-.01040	-.00180
1.985	GRADIENT	.03745	-.00224	-.00227	.00148	-.00010	.00030	-.00016	-.00016	-.00067	-.00006

AMES 97-616 IAZ 01 TO 31 PC/PT=NOM,SRM A/A=8

(RBJ014) (23 JAN 73)

REFERENCE DATA

SREF = 3155.0000 SQ.FT. XMRP = 86.4167 FT.
 LREF = 50.8000 FT. YMRP = .0000 FT.
 BREF = 73.5000 FT. ZMRP = 4.0000 FT.
 SCALE = .0190

PARAMETRIC DATA

ALPHA = .000 ELEVON = 10.000
 AILRON = .000 RUDDER = 10.000
 PLUMES = 2.000

RUN NO. 20/ 0 RN/L = 2.54 GRADIENT INTERVAL = -5.00/ 5.00

MACH	BETA	CN	CAF	CLM	CWM	CY	CYN	CBL	CABORB	CABTNK	CABSRM
1.600	-4.160	-.07000	.15410	-.00400	-.00280	.18090	-.06440	.04410	.00170	-.00040	.00100
1.600	-2.170	-.07100	.15350	-.00240	-.00160	.09460	-.03770	.02610	.00210	-.00030	.00070
1.600	-1.150	-.06600	.15310	-.00260	-.00110	.05530	-.02560	.01630	.00220	.00000	.00070
1.600	-.140	-.06500	.15350	-.00370	-.00040	.01290	-.01180	.00780	.00200	-.00040	.00050
1.600	.060	-.06800	.15370	-.00360	.00040	-.02850	.00080	-.00230	.00190	.00020	.00040
1.600	1.870	-.07200	.15480	-.00320	.00110	-.06770	.01350	-.01230	.00180	-.00080	.00020
1.600	3.870	-.07000	.15160	-.00440	.00310	-.14840	.03690	-.03070	.00190	.00000	.00050
1.600	5.890	-.07000	.15440	-.01080	.00480	-.23400	.06350	-.04970	.00140	.00180	.00080
	GRADIENT	-.00009	.00012	-.00010	.00072	-.04088	.01265	-.00935	-.00000	.00002	-.00008

RUN NO. 54/ 0 RN/L = 2.09 GRADIENT INTERVAL = -5.00/ 5.00

MACH	BETA	CN	CAF	CLM	CWM	CY	CYN	CBL	CABORB	CABTNK	CABSRM
1.985	-4.120	-.08100	.14980	.00960	-.00250	.16810	-.06630	.03910	-.00170	-.00390	-.00030
1.985	-2.110	-.07900	.14790	.00820	-.00160	.08980	-.03880	.02280	-.00130	-.00440	-.00050
1.985	-1.110	-.07800	.14820	.00820	-.00090	.05030	-.02470	.01430	-.00150	-.00510	-.00050
1.985	-.100	-.07600	.14800	.00740	-.00010	.00850	-.00960	.00590	-.00160	-.00510	-.00070
1.985	.900	-.07800	.14850	.00740	.00020	-.03390	.00590	-.00310	-.00150	-.00510	-.00080
1.985	1.910	-.07900	.14930	.00750	.00090	-.07500	.02070	-.01210	-.00180	-.00470	-.00080
1.985	3.920	-.08100	.15000	.00840	.00250	-.15220	.04750	-.02860	-.00210	-.00350	-.00050
1.985	5.930	-.07700	.15180	.00210	.00420	-.22570	.06970	-.04120	-.00090	-.00080	.00000
	GRADIENT	-.00000	.00009	-.00017	.00062	-.04016	.01433	-.00848	-.00006	.00002	-.00004

AMES 97-616 IA2 O1 TO S1 PC/PT NOM

(DBJ015) (23 OCT 73)

REFERENCE DATA

SREF = 3155.0000 SQ.FT. XMRP = 86.4167 FT.
 LREF = 50.8000 FT. YMRP = .0000 FT.
 BREF = 73.5000 FT. ZMRP = 4.0000 FT.
 SCALE = .0190

PARAMETRIC DATA

BETA = .000 ELEVON = 10.000
 AILRON = .000 RUDDER = 10.000
 PLUMES = 3.000

RUN NO. 22/ 0 RN/L = 2.57 GRADIENT INTERVAL = -5.00/ 5.00

MACH	ALPHA	CN	CAF	CLM	CMBM	CY	CYN	CBL	CABORB	CABTNK	CABSRM
1.600	-4.010	-.22800	.18530	.02270	-.00740	.01060	-.01270	.00700	.01270	.03940	.01030
1.600	-2.010	-.13900	.17990	.00530	-.00260	.01420	-.01290	.00700	.01280	.03810	.00990
1.600	-1.030	-.09600	.17670	-.00200	-.00010	.01390	-.01240	.00770	.01260	.03730	.00960
1.600	.060	-.05200	.17420	-.01050	.00220	.01260	-.01230	.00680	.01280	.03670	.00930
1.600	.980	-.01200	.17190	-.01990	.00460	.01330	-.01250	.00690	.01290	.03580	.00910
1.600	2.030	.03400	.16980	-.03080	.00720	.01300	-.01210	.00570	.01300	.03440	.00880
1.600	4.000	.11500	.16570	-.05150	.01250	.00920	-.01010	.00520	.01320	.03350	.00850
1.600	6.030	.20700	.16260	-.07800	.01760	.00670	-.00890	.00430	.01360	.03370	.00840
1.600	8.050	.30000	.15990	-.10170	.02240	.00240	-.00940	.00380	.01350	.03250	.00810
1.600	10.040	.38600	.15660	-.11770	.02560	.00260	-.00870	.00320	.01300	.03160	.00790
GRADIENT		.04277	-.00245	-.00918	.00247	-.00020	.00028	-.00025	.00006	-.00077	-.00024

RUN NO. 56/ 0 RN/L = 2.08 GRADIENT INTERVAL = -5.00/ 5.00

MACH	ALPHA	CN	CAF	CLM	CMBM	CY	CYN	CBL	CABORB	CABTNK	CABSRM
1.985	-3.630	-.23100	.17650	.03000	-.00490	.00480	-.00760	.00430	.00760	.03310	.00850
1.985	-1.640	-.14200	.17070	.01220	-.00190	.00690	-.00780	.00440	.00740	.03090	.00790
1.985	-.610	-.10000	.16810	.00380	-.00020	.00600	-.00770	.00440	.00750	.02990	.00760
1.985	.360	-.05900	.16550	-.00510	.00210	.00660	-.00780	.00450	.00750	.02920	.00740
1.985	1.350	-.01900	.16390	-.01280	.00420	.00680	-.00770	.00400	.00750	.02830	.00710
1.985	2.330	.02200	.16240	-.01940	.00680	.00630	-.00740	.00410	.00730	.02700	.00670
1.985	4.360	.10400	.15980	-.03070	.01170	.00520	-.00640	.00360	.00680	.02430	.00620
1.985	6.350	.18200	.15760	-.03960	.01490	.00220	-.00540	.00290	.00670	.02360	.00600
1.985	8.370	.26300	.15530	-.04680	.01780	.00130	-.00530	.00280	.00690	.02380	.00600
1.985	10.330	.34900	.15180	-.05750	.02010	.00020	-.00520	.00250	.00740	.02380	.00580
GRADIENT		.04178	-.00209	-.00771	.00211	.00003	.00013	-.00009	-.00008	-.00107	-.00029

AMES 97-616 IAS 01 TO 51 PC/PT NOM

(CBJ016) (23 OCT 73)

REFERENCE DATA

SREF = 3155.0000 SQ.FT. XMRP = 86.4167 FT.
 LREF = 59.8000 FT. YMRP = .0000 FT.
 BREF = 73.5000 FT. ZMRP = 4.0000 FT.
 SCALE = .0190

PARAMETRIC DATA

ALPHA = .000 ELEVON = 10.000
 AILRON = .000 RUDDER = 10.000
 PLUMES = 3.000

RUN NO. 28/ 0 RN/L = 2.55 GRADIENT INTERVAL = -5.00/ 5.00

MACH	BETA	CN	CAF	CLM	CWB	CY	CYN	CBL	CASORB	CABTNK	CABSRM
1.600	-4.160	-.06400	.17550	-.00690	-.00220	.17760	-.06460	.04660	.01310	.03760	.00980
1.600	-2.160	-.06600	.17510	-.00680	-.00020	.09470	-.03790	.02640	.01280	.03720	.00950
1.600	-1.150	-.06200	.17530	-.00740	.00080	.05350	-.02560	.01650	.01300	.03710	.00950
1.600	-.140	-.06200	.17520	-.00740	.00190	.01240	-.01260	.00760	.01300	.03720	.00950
1.600	.870	-.06300	.17540	-.00620	.00280	-.02770	.00050	-.00370	.01270	.03670	.00950
1.600	1.880	-.06500	.17520	-.00590	.00370	-.06950	.01300	-.01380	.01280	.03700	.00970
1.600	3.890	-.06700	.17600	-.00540	.00610	-.15270	.03990	-.03340	.01340	.03700	.00960
1.600	5.910	-.06600	.17480	-.00850	.00810	-.23890	.06750	-.05300	.01410	.03740	.00970
	GRADIENT	-.00026	.00005	.00021	.00102	-.04092	.01291	-.00994	.00002	-.00008	-.00001

RUN NO. 55/ 0 RN/L = 2.08 GRADIENT INTERVAL = -5.00/ 5.00

MACH	BETA	CN	CAF	CLM	CWB	CY	CYN	CBL	CASORB	CABTNK	CABSRM
1.985	-4.120	-.06600	.16750	-.00580	-.00170	.17120	-.06650	.03930	.00700	.02880	.00700
1.985	-2.110	-.06800	.16620	-.00450	.00020	.09020	-.03700	.02240	.00710	.02880	.00720
1.985	-1.110	-.06700	.16610	-.00420	.00080	.04940	-.02280	.01340	.00750	.02890	.00740
1.985	-.100	-.06600	.16570	-.00370	.00160	.00850	-.00810	.00430	.00760	.02910	.00740
1.985	.900	-.06900	.16590	-.00210	.00270	-.03350	.00690	-.00490	.00750	.02920	.00740
1.985	1.910	-.06900	.16580	-.00190	.00370	-.07640	.02300	-.01480	.00760	.02920	.00750
1.985	3.920	-.07000	.16710	-.00070	.00560	-.15490	.05050	-.03140	.00800	.02920	.00740
1.985	5.930	-.07400	.16740	-.00030	.00740	-.23490	.07690	-.04650	.00830	.02920	.00720
	GRADIENT	-.00047	-.00006	.00066	.00090	-.04076	.01463	-.00890	.00012	.00006	.00005

AMES 97-616 I22 01 TO S1 SRM A/A=12,ORB NOM

(RBJ017) (23 JAN 73)

REFERENCE DATA

SREF = 3155.0000 SQ.FT. XMRP = 86.4167 FT.
 LREF = 50.8000 FT. YMRP = .0000 FT.
 BREF = 73.5000 FT. ZMRP = 4.0000 FT.
 SCALE = .0190

PARAMETRIC DATA

BETA = .000 ELEVON = 10.000
 AILRON = .000 RUDDER = 10.000
 PLUMES = 5.000

RUN NO. 16/ 0 RN/L = 2.56 GRADIENT INTERVAL = -5.00/ 5.00

MACH	ALPHA	CN	CAF	CLM	CWM	CY	CYN	CBL	CABORB	CABTNK	CABSRM
1.600	-4.030	-.21300	.17600	.00080	-.00670	.01110	-.01260	.00570	.00510	.01900	.00510
1.600	-2.040	-.12900	.16940	-.01110	-.00300	.01230	-.01160	.00650	.00500	.01720	.00470
1.600	-1.020	-.08900	.16750	-.01710	-.00070	.01480	-.01220	.00660	.00490	.01580	.00440
1.600	.000	-.05100	.16310	-.01880	.00120	.01350	-.01170	.00570	.00500	.01520	.00430
1.600	.980	-.01000	.16020	-.02170	.00290	.01190	-.01130	.00580	.00520	.01490	.00420
1.600	1.990	.03100	.16150	-.02790	.00530	.01310	-.01120	.00560	.00650	.01570	.00430
1.600	3.920	.12200	.15950	-.05910	.01170	.00940	-.00940	.00550	.00700	-.01500	.00410
1.600	5.990	.21100	.15670	-.08680	.01700	.00500	-.00730	.00400	.00720	.01450	.00370
1.600	8.000	.29300	.15160	-.09410	.01960	.00150	-.00760	.00400	.00730	.01040	.00280
1.600	9.970	.35800	.14670	-.08010	.01860	.00010	-.00670	.00310	.00600	.00990	.00270
	GRADIENT	.04153	-.00213	-.00662	.00224	-.00019	.00034	-.00003	.00026	-.00048	-.00012

RUN NO. 51/ 0 RN/L = 2.05 GRADIENT INTERVAL = -5.00/ 5.00

MACH	ALPHA	CN	CAF	CLM	CWM	CY	CYN	CBL	CABORB	CABTNK	CABSRM
1.985	-3.710	-.22600	.16380	.01580	-.00570	.00280	-.00570	.00330	-.00060	.00770	.00200
1.985	-1.730	-.14200	.15740	.00630	-.00320	.00300	-.00480	.00310	-.00090	.00770	.00200
1.985	-.720	-.10800	.15340	.00240	-.00180	.00260	-.00450	.00340	-.00110	.00670	.00180
1.985	.290	-.06600	.15120	-.00300	.00010	.00500	-.00500	.00350	-.00110	.00560	.00160
1.985	1.340	-.02600	.14900	-.00740	.00210	.00330	-.00380	.00270	-.00130	.00460	.00140
1.985	2.340	.00900	.14970	-.00490	.00430	.00370	-.00430	.00260	-.00070	.00320	.00120
1.985	4.350	.09100	.14750	-.01710	.00880	.00160	-.00280	.00180	-.00100	.00200	.00090
1.985	6.310	.16800	.14630	-.02810	.01190	.00020	-.00260	.00180	-.00080	-.00080	.00020
	GRADIENT	.03892	-.00200	-.00386	.00181	-.00006	.00031	-.00019	-.00003	-.00080	-.00015

AMES 97-616 IAZ 01 TO S1 SRM A/A=12,ORB NOM

(RBJ018) (23 JAN 73)

REFERENCE DATA

SREF = 3155.0000 SQ.FT. XMRP = 86.4167 FT.
 LREF = 50.8000 FT. YMRP = .0000 FT.
 BREF = 73.5000 FT. ZMRP = 4.0000 FT.
 SCALE = .0190

PARAMETRIC DATA

ALPHA = .000 ELEVON = 10.000
 AILRON = .000 RUDDER = 10.000
 PLUMES = 5.000

RUN NO. 19/ 0 RN/L = 2.54 GRADIENT INTERVAL = -5.00/ 5.00

MACH	BETA	CN	CAF	CLM	CWBM	CY	CYN	CBL	CABORB	CABTNK	CABSRM
1.600	-4.160	-.05600	-.16520	-.02340	-.00170	.17550	-.06200	.04280	.00510	.01650	.00460
1.600	-2.170	-.05600	.16470	-.02030	-.00020	.09360	-.03640	.02480	.00530	.01610	.00450
1.600	-1.160	-.05900	.16460	-.01800	.00010	.05370	-.02420	.01570	.00510	.01570	.00440
1.600	-.140	-.05400	.16450	-.01940	.00090	.01250	-.01170	.00720	.00510	.01560	.00440
1.600	.860	-.05700	.16470	-.01770	.00150	-.02940	.00110	-.00250	.00500	.01540	.00440
1.600	1.870	-.05800	.16410	-.01710	.00220	-.06910	.01310	-.01220	.00480	.01470	.00430
1.600	3.880	-.05700	.16540	-.02030	.00480	-.14800	.03720	-.03160	.00480	.01490	.00440
1.600	5.910	-.05500	.16540	-.02670	.00700	-.23440	.06380	-.04960	.00510	.01600	.00460
	GRADIENT	-.00014	-.00001	.00045	.00076	-.04029	.01233	-.00922	-.00005	-.00022	-.00003

RUN NO. 50/ 0 RN/L = 2.08 GRADIENT INTERVAL = -5.00/ 5.00

MACH	BETA	CN	CAF	CLM	CWBM	CY	CYN	CBL	CABORB	CABTNK	CABSRM
1.985	-4.110	-.06900	.15340	-.00610	-.00250	.16670	-.06260	.03760	-.00110	.00570	.00150
1.985	-2.120	-.07100	.15150	-.00360	-.00160	.08700	-.03340	.02040	-.00130	.00550	.00150
1.985	-1.120	-.07100	.15320	-.00390	-.00080	.04680	-.02010	.01260	-.00100	.00630	.00180
1.985	-.110	-.06900	.15260	-.00280	-.00010	.00700	-.00560	.00350	-.00080	.00680	.00190
1.985	.900	-.07300	.15170	-.00040	.00060	-.03360	.00830	-.00460	-.00120	.00470	.00160
1.985	1.910	-.07300	.15260	-.00100	.00170	-.07560	.02300	-.01400	-.00090	.00600	.00180
1.985	3.900	-.07300	.15440	-.00320	.00410	-.15200	.04880	-.03010	-.00050	.00690	.00170
1.985	5.930	-.07200	.15620	-.00620	.00640	-.22670	.07110	-.04400	-.00030	.00740	.00180
	GRADIENT	-.00052	.00011	.00048	.00082	-.03990	.01393	-.00847	.00007	.00010	.00003

AMES 97-616 IAZ 01 TO S1 PC/PT=1.3 NOMINAL

(RBJ019) (23 JAN 73)

REFERENCE DATA

SREF = 3155.0000 SQ.FT. XMRP = 86.4167 FT.
 LREF = 90.0000 FT. YMRP = .0000 FT.
 BREF = 73.5000 FT. ZMRP = 4.0000 FT.
 SCALE = .0190

PARAMETRIC DATA

BETA = .000 ELEVON = 10.000
 AILRON = .000 RUDDER = 10.000
 PLUMES = 5.000

RUN NO. 26/ 0 RN/L = 1.99 GRADIENT INTERVAL = -5.00/ 5.00

MACH	ALPHA	CN	CAF	CLM	CWM	CY	CYN	CBL	CABORB	CABTNK	CABSRM
1.600	-4.080	-.21600	.15750	-.01050	-.00410	.00390	-.00720	.00500	-.00320	-.00610	-.00090
1.600	-2.050	-.14500	.15230	.00250	-.00400	.00650	-.00560	.00350	-.00310	-.00760	-.00120
1.600	-1.090	-.10800	.14780	-.00110	-.00190	.00550	-.00510	.00440	-.00300	-.00850	-.00130
1.600	-.110	-.07000	.14580	-.00520	.00030	.00450	-.00560	.00420	-.00330	-.00990	-.00160
1.600	.930	-.02700	.14340	-.01100	.00240	.00580	-.00580	.00400	-.00330	-.01080	-.00200
1.600	1.940	.01400	.14040	-.01740	.00440	.00580	-.00550	.00300	-.00310	-.01100	-.00240
1.600	3.960	.09400	.13740	-.03720	.00960	.00340	-.00410	.00300	-.00330	-.01140	-.00240
1.600	5.900	.17200	.13530	-.05150	.01250	-.00460	-.00090	.00160	-.00330	-.01210	-.00240
1.600	7.960	.23800	.13230	-.04130	.01280	-.00420	-.00150	.00170	-.00390	-.01230	-.00280
1.600	9.990	.30500	.12990	-.02600	.01340	-.00310	-.00270	.00110	-.00420	-.01360	-.00280
GRADIENT		.03888	-.00257	-.00372	.00180	-.00007	.00028	-.00022	-.00002	-.00072	-.00022

RUN NO. 52/ 0 RN/L = 1.64 GRADIENT INTERVAL = -5.00/ 5.00

MACH	ALPHA	CN	CAF	CLM	CWM	CY	CYN	CBL	CABORB	CABTNK	CABSRM
1.985	-3.760	-.22600	.15030	.00280	-.00300	-.00180	-.00120	.00200	-.00850	-.01420	-.00340
1.985	-1.730	-.14400	.14170	.00040	-.00150	-.00220	.00100	.00070	-.00960	-.01710	-.00400
1.985	-.690	-.10700	.13870	.00080	-.00070	-.00190	.00070	.00040	-.00960	-.01790	-.00410
1.985	.260	-.07300	.13730	-.00140	-.00020	-.00190	.00040	.00140	-.00940	-.01820	-.00410
1.985	1.300	-.03400	.13570	-.00620	.00170	-.00210	.00060	.00110	-.00960	-.01880	-.00420
1.985	2.340	.00500	.13460	-.01190	.00380	-.00230	.00110	.00050	-.00980	-.02030	-.00470
1.985	4.310	.08200	.13230	-.01740	.00800	-.00310	.00150	-.00080	-.01010	-.02150	-.00510
1.985	6.350	.14600	.13010	-.00960	.00950	-.00430	.00200	-.00080	-.01090	-.02260	-.00530
1.985	8.320	.21000	.12910	.00380	.01040	-.00060	-.00190	-.00060	-.01110	-.02370	-.00550
1.985	10.350	.29300	.12680	-.00140	.01200	-.00280	-.00140	-.00030	-.01070	-.02300	-.00500
GRADIENT		.03780	-.00211	-.00265	.00134	-.00013	.00026	-.00026	-.00016	-.00086	-.00020

AMES 97-616 IA2 01 TO S1 PC/PT=1.3 NOMINAL

(RBJ020) (23 JAN 73)

REFERENCE DATA

SREF = 3155.0000 SQ.FT. XMRP = 86.4167 FT.
 LREF = 50.8000 FT. YMRP = .0000 FT.
 BREF = 73.5500 FT. ZMRP = 4.0000 FT.
 SCALE = .0190

PARAMETRIC DATA

ALPHA = .000 ELEVON = 10.000
 AILRON = .000 RUDDER = 10.000
 PLUMES = 5.000

RUN NO. 27/ 0 RN/L = 2.03 GRADIENT INTERVAL = -5.00/ 5.00

MACH	BETA	CN	CAF	CLM	CWBM	CY	CYN	CBL	CABORB	CABTNK	CABSRM
1.600	-4.150	-.07300	.14750	-.00640	-.00260	.16460	-.05230	.03940	-.00300	-.00980	-.00180
1.600	-2.160	-.07600	.14590	-.00320	-.00150	.08240	-.02740	.02140	-.00330	-.00910	-.00180
1.600	-1.150	-.07800	.14600	-.00330	-.00110	.04640	-.01800	.01310	-.00320	-.00810	-.00150
1.600	-.140	-.07500	.14590	-.00380	-.00030	.00600	-.00630	.00380	-.00320	-.00920	-.00140
1.600	.860	-.07600	.14630	-.00380	.00070	-.03140	.00440	-.00480	-.00350	-.00820	-.00150
1.600	1.870	-.07500	.14730	-.00460	.00130	-.07160	.01620	-.01350	-.00350	-.00860	-.00160
1.600	3.880	-.07300	.14710	-.00780	.00280	-.14810	.03830	-.03160	-.00270	-.00900	-.00140
1.600	5.900	-.07400	.14700	-.01250	.00490	-.22800	.05920	-.04730	-.00250	-.00720	-.00120
	GRADIENT	.00010	.00004	-.00021	.00069	-.03879	.01119	-.00881	.00001	.00010	.00005

RUN NO. 53/ 0 RN/L = 1.63 GRADIENT INTERVAL = -5.00/ 5.00

MACH	BETA	CN	CAF	CLM	CWBM	CY	CYN	CBL	CABORB	CABTNK	CABSRM
1.985	-4.130	-.07300	.14080	-.01070	.00260	.14000	-.04280	.02880	-.00880	-.01710	-.00400
1.985	-2.110	-.07600	.13720	-.00700	.00010	.07470	-.02390	.01810	-.00940	-.01770	-.00440
1.985	-1.110	-.07900	.13770	-.00320	-.00030	.03760	-.01270	.00940	-.00950	-.01870	-.00430
1.985	-.110	-.08100	.13760	-.00050	-.00030	.00040	-.00030	.00180	-.00920	-.01800	-.00400
1.985	.900	-.08200	.13930	.00060	.00010	-.03810	.01140	-.00640	-.00910	-.01670	-.00400
1.985	1.910	-.08100	.13910	-.00020	.00100	-.07400	.02160	-.01400	-.00850	-.01570	-.00390
1.985	3.910	-.07700	.14260	-.01350	.00210	-.12830	.03300	-.02060	-.00750	-.01560	-.00370
1.985	5.920	-.07800	.14420	-.01260	.00350	-.19650	.04720	-.02970	-.00690	-.01480	-.00360
	GRADIENT	-.00069	.00030	.00015	.00000	-.03427	.00991	-.00648	.00018	.00028	.00006

AMES 97-616 IA2 01 TO S1 PC/PT=NOM SRM A/A=8

(RBJ021) (23 JAN 73)

REFERENCE DATA

SREF = 3155.0000 SQ.FT. XMRP = 86.4167 FT.
 LREF = 50.8000 FT. YMRP = .0000 FT.
 BREF = 73.5000 FT. ZMRP = 4.0000 FT.
 SCALE = .0190

PARAMETRIC DATA

BETA = .000 ELEVON = -10.000
 AILRON = .000 RUDDER = 10.000
 PLUMES = 5.000

RUN NO. 29/ 0 RN/L = 2.61 GRADIENT INTERVAL = -5.00/ 5.00

MACH	ALPHA	CN	CAF	CLM	CWM	CY	CYN	CBL	CABORB	CABTNK	CABSRM
1.600	-4.100	-.23800	.16590	.04090	-.00700	.00930	-.01090	.00640	-.00110	.00450	.00150
1.600	-2.120	-.17300	.16030	.04820	-.00700	.01130	-.00990	.00540	-.00140	.00150	.00060
1.600	-1.090	-.13200	.15460	.04260	-.00500	.01050	-.01000	.00520	-.00090	.00130	.00090
1.600	-.100	-.08700	.15260	.03820	-.00310	.00950	-.00980	.00540	-.00060	.00130	.00120
1.600	.920	-.04900	.14950	.02930	-.00080	.00850	-.00920	.00540	-.00090	.00040	.00100
1.600	1.890	-.01100	.14710	.02290	.00130	.01110	-.00950	.00410	-.00030	.00070	.00120
1.600	3.880	.06800	.14420	.01210	.00570	.00970	-.00840	.00410	.00090	.00180	.00140
1.600	5.920	.14900	.14310	-.00340	.00990	.00430	-.00710	.00380	.00150	-.00030	.00080
1.600	7.880	.22500	.14020	-.00420	.01070	.00240	-.00600	.00430	.00080	-.00200	.00030
1.600	9.900	.29400	.13770	.00380	.01250	.00250	-.00790	.00020	-.00090	-.00220	.00030
	GRADIENT	.03888	-.00282	-.00427	.00171	-.00002	.00028	-.00028	.00024	-.00032	.00002

RUN NO. 64/ 0 RN/L = 2.11 GRADIENT INTERVAL = -5.00/ 5.00

MACH	ALPHA	CN	CAF	CLM	CWM	CY	CYN	CBL	CABORB	CABTNK	CABSRM
1.985	-3.770	-.23300	.15330	.01840	-.00250	-.00070	-.00300	.00270	-.00660	-.00680	-.00150
1.985	-1.700	-.16000	.14770	.02580	-.00400	-.00060	-.00250	.00290	-.00630	-.00900	-.00200
1.985	-.740	-.12500	.14580	.02450	-.00290	.00070	-.00250	.00190	-.00620	-.00990	-.00210
1.985	.260	-.08900	.14260	.02280	-.00190	.00180	-.00300	.00270	-.00600	-.01030	-.00200
1.985	1.260	-.04900	.14010	.01640	.00020	-.00020	-.00220	.00230	-.00580	-.00980	-.00180
1.985	2.260	-.01000	.13850	.01190	.00250	.00040	-.00290	.00230	-.00590	-.01050	-.00200
1.985	4.230	.06300	.13680	.01200	.00540	-.00150	-.00130	.00220	-.00620	-.01120	-.00210
1.985	6.240	.13700	.13420	.00920	.00770	-.00380	-.00020	.00180	-.00630	-.01280	-.00260
1.985	8.250	.21400	.13220	.00550	.01040	-.00380	-.00030	.00150	-.00570	-.01380	-.00280
1.985	10.230	.30000	.13200	-.00270	.01260	-.00430	-.00030	.00190	-.00540	-.01440	-.00290
	GRADIENT	.03721	-.00215	-.00146	.00113	-.00005	.00019	-.00007	.00007	-.00049	-.00005

AMES 97-816 1A2 01 TO S1 PC/PT=NOM SRM A/A=8

(RBJ022) (23 JAN 73)

REFERENCE DATA

SREF = 3155.0000 SQ.FT. XMRP = 89.4167 FT.
 LREF = 50.8000 FT. YMRP = .0000 FT.
 BREF = 73.5000 FT. ZMRP = 4.0000 FT.
 SCALE = .0190

PARAMETRIC DATA

BETA = .000 ELEVON = .000
 AILRON = 10.000 RUDDER = .000
 PLUMES = 5.000

RUN NO. 61/ D RN/L = 2.09 GRADIENT INTERVAL = -5.00/ 5.00

MACH	ALPHA	CN	CAF	CLM	CWB	CY	CYN	CBL	CABRB	CABTK	CABSRM
1.984	-3.700	-.20400	.15720	.01030	-.00340	-.00300	.00290	.00080	-.00530	-.00780	-.00180
1.984	-1.720	-.13800	.15030	.01450	-.00390	-.00140	.00250	.00080	-.00580	-.00990	-.00220
1.984	-.720	-.10500	.14760	.01070	-.00310	-.00060	.00210	.00150	-.00600	-.01040	-.00240
1.984	.290	-.07200	.14370	.00850	-.00190	-.00190	.00230	.00190	-.00570	-.01100	-.00240
1.984	1.260	-.03700	.14250	.00370	.00020	-.00050	.00170	.00140	-.00600	-.01110	-.00230
1.984	2.250	.00100	.13990	.00060	.00230	-.00060	.00160	.00110	-.00570	-.01090	-.00230
1.984	4.280	.07600	.13930	-.00230	.00530	-.00220	.00240	.00170	-.00610	-.01290	-.00260
1.984	6.290	.14900	.13660	-.00300	.00790	-.00370	.00280	.00070	-.00650	-.01410	-.00320
1.984	8.290	.22100	.13500	-.00050	.01030	-.00590	.00300	-.00070	-.00640	-.01510	-.00320
1.984	10.280	.30500	.13370	-.00580	.01260	-.00420	.00160	-.00100	-.00590	-.01530	-.00340
	GRADIENT	.03504	-.00233	-.00204	.00121	.00012	-.00010	.00010	-.00007	-.00056	-.00008

AMES 97-616 IA2 01 TO S1 PC/PT=NOM SRM A/A=8

(RBJ023) (23 JAN 73)

REFERENCE DATA

SREF = 3155.0000 SQ.FT. XMRP = 86.4167 FT.
 LREF = 50.8000 FT. YMRP = .0000 FT.
 BREF = 73.5000 FT. ZMRP = 4.0000 FT.
 SCALE = .0190

PARAMETRIC DATA

ALPHA = .000 ELEVON = .000
 AILRON = 10.000 RUDDER = .000
 PLUMES = 5.000

RUN NO. 30/ 0 RN/L = 2.58 GRADIENT INTERVAL = -5.00/ 5.00

MACH	BETA	CN	CAF	CLM	CWBM	CY	CYN	CBL	CABORB	CABTNK	CABSRM
1.600	-4.170	-.08500	.15370	.02020	-.00720	.16010	-.04680	.04080	.00000	-.00060	.00090
1.600	-2.160	-.00100	.15270	.01810	-.00510	.08050	-.02350	.02260	.00010	.00030	.00080
1.600	-1.150	-.07700	.15270	.01470	-.00420	.04290	-.01230	.01350	.00010	.00050	.00070
1.600	-.140	-.07900	.15290	.01410	-.00330	.00250	.00020	.00440	.00040	.00030	.00070
1.600	.860	-.08000	.15310	.01300	-.00240	-.00380	.01170	-.00470	.00020	.00060	.00050
1.600	1.870	-.08100	.15350	.01250	-.00130	-.07770	.02380	-.01450	.00010	-.00020	.00050
1.600	3.890	-.07900	.15390	.01020	.00020	-.15690	.04770	-.03220	.00080	.00080	.00070
1.600	5.900	-.08200	.15350	.00710	.00160	-.24160	.07350	-.04930	.00070	.00220	.00090
	GRADIENT	.00050	.00007	-.00125	.00092	-.03938	.01174	-.00909	.00008	.00011	-.00004

RUN NO. 60/ 0 RN/L = 2.11 GRADIENT INTERVAL = -5.00/ 5.00

MACH	BETA	CN	CAF	CLM	CWBM	CY	CYN	CBL	CABORB	CABTNK	CABSRM
1.984	-4.130	-.07600	.14980	.02220	-.00450	.15790	-.05060	.03520	-.00590	-.01020	-.00190
1.984	-2.120	-.07200	.14860	.01840	-.00290	.07940	-.02460	.01920	-.00620	-.01030	-.00220
1.984	-1.110	-.06600	.14600	.01450	-.00240	.03960	-.01180	.01040	-.00560	-.00970	-.00190
1.984	-.100	-.06200	.14700	.01040	-.00140	-.00010	.00160	.00190	-.00600	-.01090	-.00230
1.984	.900	-.06200	.14670	.00720	-.00050	-.00340	.01350	-.00590	-.00600	-.01070	-.00250
1.984	1.900	-.06300	.14590	.00450	.00070	-.07000	.02630	-.01410	-.00590	-.01100	-.00250
1.984	3.920	-.06500	.14680	.00210	.00190	-.15390	.05100	-.02980	-.00550	-.01040	-.00210
1.984	5.920	-.06800	.14630	-.00320	.00290	-.21340	.06620	-.03900	-.00390	-.00660	-.00150
	GRADIENT	.00156	-.00040	-.00273	.00082	-.03884	.01263	-.00812	.00004	-.00008	-.00005

AMES 97-616 IA2 01 TO S1 SRM A/A=12,CRB NOM

(RBJ024) (23 JAN 73)

REFERENCE DATA

SREF = 3155.0000 SQ.FT. XMRP = 86.4167 FT.
 LREF = 50.8000 FT. YMRP = .0000 FT.
 BREF = 73.5000 FT. ZMRP = 4.0000 FT.
 SCALE = .0190

PARAMETRIC DATA

BETA = .000 ELEVON = .000
 AILRON = 10.000 RUDDER = .000
 PLUMES = 5.000

RUN NO. 62/ 0 RN/L = 2.06 GRADIENT INTERVAL = -5.00/ 5.00

MACH	ALPHA	CN	CAF	CLM	CwBM	CY	CYN	CBL	CABORB	CABTNK	CABSRM
1.984	-3.640	-.23700	.16560	.03510	-.00820	-.00120	.00080	.00420	.00000	.00880	.00220
1.984	-1.690	-.15600	.15880	.02720	-.00640	.00090	.00050	.00420	-.00100	.00800	.00200
1.984	-.690	-.11600	.15520	.02170	-.00480	.00090	.00030	.00450	-.00130	.00660	.00170
1.984	.200	-.07700	.15220	.01620	-.00310	.00100	.00030	.00430	-.00130	.00620	.00170
1.984	1.320	-.03800	.15210	.01150	-.00110	.00100	.00020	.00410	-.00180	.00460	.00140
1.984	2.360	-.00300	.15250	.01480	.00070	.00210	.00000	.00420	-.00120	.00500	.00140
1.984	4.310	.07300	.15030	.00730	.00470	-.00110	.00130	.00420	-.00100	.00430	.00130
1.984	6.320	.15400	.14680	-.00260	.00770	-.00210	.00060	.00470	.00010	.00320	.00110
1.984	8.330	.23300	.14300	-.00790	.01070	-.00240	.00070	.00310	.00050	.00100	.00060
1.984	10.340	.32000	.14320	-.01790	.01330	-.00320	.00040	.00250	.00030	-.00150	-.00030
	GRADIENT	.03874	-.00183	-.00348	.00166	.00007	.00002	-.00001	-.00012	-.00062	-.00012

AMES 97-616 IA2 01 TO S1 PC/PT=NOM,SRM A/A=8

(RBJ025) (23 JAN 73)

REFERENCE DATA

SREF = 3155.0000 SQ.FT. XMRP = 86.4167 FT.
 LREF = 50.8000 FT. YMRP = .0000 FT.
 BREF = 73.5000 FT. ZMRP = 4.0000 FT.
 SCALE = .0190

PARAMETRIC DATA

ALPHA = -5.000 ELEVON = .000
 AILRON = .000 RUDDER = .000
 PLUMES = 5.000

RUN NO. 33/ 0 RN/L = 2.07 GRADIENT INTERVAL = -5.00/ 5.00

MACH	BETA	CN	CAF	CLM	CwBM	CY	CYN	CBL	CABORB	CABTNK	CABSRM
1.985	-4.120	-.25900	.15990	.00050	-.00180	.14730	-.04340	.02530	-.00450	-.00370	-.00130
1.985	-2.110	-.25300	.15760	-.00720	-.00090	.07020	-.01920	.01330	-.00470	-.00410	-.00090
1.985	-1.120	-.25600	.15760	-.00790	-.00080	.03400	-.00850	.00690	-.00460	-.00420	-.00090
1.985	-.110	-.25300	.15710	-.00810	-.00070	-.00540	.00240	.00010	-.00420	-.00360	-.00070
1.985	.890	-.25300	.15620	-.00840	-.00030	-.04110	.01200	-.00660	-.00420	-.00390	-.00070
1.985	1.900	-.25600	.15700	-.00790	-.00050	-.07930	.02350	-.01360	-.00420	-.00350	-.00060
1.985	3.910	-.26300	.15890	-.00440	-.00130	-.15360	.04510	-.02530	-.00420	-.00220	-.00030
1.985	5.910	-.27800	.16050	.01350	-.00310	-.23450	.07120	-.03680	-.00330	-.00230	-.00040
	GRADIENT	-.00045	-.00016	-.00051	.00008	-.03743	.01091	-.00640	.00006	.00018	.00011

AMES 97-616 IA2 01 TO S1 PC/PT=NOM,SRM A/A=8

(RBJD26) (23 JAN 73)

REFERENCE DATA

SREF = 3155.0000 SQ.FT. XMRP = 86.4167 FT.
 LREF = 50.8000 FT. YMRP = .0000 FT.
 BREF = 73.5000 FT. ZMRP = 4.0000 FT.
 SCALE = .0190

PARAMETRIC DATA

ALPHA = 5.000 ELEVON = .000
 AILRON = .000 RUDDER = .000
 PLUMES = 5.000

RUN NO. 35/ 0 RN/L = 2.08 GRADIENT INTERVAL = -5.00/ 5.00

MACH	BETA	CN	CAF	CLM	CMBM	CY	CYN	CBL	CABORB	CABTNK	CABSRM
1.985	-4.110	.11700	.13680	-.00990	.00730	.14040	-.04210	.02820	-.00520	-.01220	-.00250
1.985	-2.110	.11700	.13630	-.01100	.00800	.06880	-.01900	.01340	-.00580	-.01330	-.00260
1.985	-1.110	.11700	.13590	-.01390	.00830	.03030	-.00730	.00630	-.00570	-.01270	-.00260
1.985	-.110	.11700	.13630	-.01410	.00860	-.00690	.00400	-.00020	-.00550	-.01240	-.00250
1.985	.890	.12400	.13680	-.01610	.00900	-.04290	.01470	-.00560	-.00510	-.01210	-.00250
1.985	1.890	.12100	.13740	-.01900	.01070	-.07970	.02620	-.01380	-.00500	-.01190	-.00240
1.985	3.890	.11600	.13730	-.01440	.01170	-.15480	.05190	-.03010	-.00420	-.01090	-.00210
1.985	5.890	.11600	.13750	-.01590	.01280	-.22890	.07340	-.04290	-.00330	-.00970	-.00200
	GRADIENT	.00026	.00011	-.00086	.00056	-.03693	.01163	-.00713	.00015	.00020	.00005

AMES 97-616 IA2 01 TO S1 CMS,PC/PT=NOM,SRM A/A=8

(RBJD27) (23 JAN 73)

REFERENCE DATA

SREF = 3155.0000 SQ.FT. XMRP = 86.4167 FT.
 LREF = 50.8000 FT. YMRP = .0000 FT.
 BREF = 73.5000 FT. ZMRP = 4.0000 FT.
 SCALE = .0190

PARAMETRIC DATA

BETA = .000 ELEVON = .000
 AILRON = .000 RUDDER = .000
 PLUMES = 5.000

RUN NO. 4/ 0 RN/L = 2.60 GRADIENT INTERVAL = -5.00/ 5.00

MACH	ALPHA	CN	CAF	CLM	CMBM	CY	CYN	CBL	CABORB	CABTNK	CABSRM
1.600	-4.120	-.24700	.17530	.05100	-.00430	.00120	-.00050	.00040	.00230	.00740	.00220
1.600	-3.120	-.21600	.17250	.05820	-.00510	.00550	-.00060	.00050	.00240	.00560	.00150
1.600	-2.090	-.18400	.16900	.06730	-.00570	.00510	-.00220	.00060	.00170	.00430	.00180
1.600	-1.080	-.14400	.16590	.06320	-.00350	.00700	-.00240	.00020	.00180	.00300	.00170
1.600	-.100	-.11200	.16540	.06910	-.00290	.00380	-.00140	.00020	.00240	.00460	.00220
1.600	.900	-.07100	.16150	.06100	-.00080	.00540	-.00170	-.00020	.00210	.00230	.00160
1.600	1.940	-.03000	.15980	.05530	.00140	.00250	-.00100	.00040	.00220	.00180	.00150
1.600	2.920	.01100	.15700	.04770	.00340	.00240	-.00100	.00010	.00240	.00230	.00160
1.600	3.940	.05100	.15790	.03910	.00600	.00060	-.00020	.00010	.00330	.00130	.00140
1.600	5.940	.12700	.15440	.03380	.00790	.00120	-.00010	-.00120	.00460	.00070	.00090
1.600	7.950	.20900	.14940	.02810	.00990	-.00590	.00140	-.00020	.00410	-.00090	.00050
1.600	9.970	.28000	.14650	.02800	.01100	-.00180	-.00100	-.00060	.00330	-.00140	.00040
	GRADIENT	.03732	-.00230	-.00174	.00140	-.00031	.00005	-.00005	.00009	-.00066	-.00006

AMES 97-616 IAZ 01 TO S1 CMS,PC/PT=NOM,SRM A/A=8

(RBJ026) (23 JAN 73)

REFERENCE DATA

SREF = 3155.0000 SQ.FT. XMRP = 86.4167 FT.
 LREF = 50.8000 FT. YMRP = .0000 FT.
 BREF = 73.5000 FT. ZMRP = 4.0000 FT.
 SCALE = .0190

PARAMETRIC DATA

ALPHA = -5.000 ELEVON = .000
 AILRON = .000 RUDDER = .000
 PLUMES = 5.000

RUN NO. 5/ 0 RN/L = 2.54 GRADIENT INTERVAL = -5.00/ 5.00

MACH	BETA	CN	CAF	CLM	CWM	CY	CYN	CBL	CABORB	CABTNK	CABSRM
1.600	-4.170	-.30800	.18010	.07210	-.00930	.16910	-.05520	.04010	.00400	.01120	.00270
1.600	-3.170	-.30800	.18000	.07020	-.00860	.13090	-.04270	.03140	.00340	.01120	.00270
1.600	-2.160	-.30400	.18000	.06830	-.00800	.08920	-.02920	.02220	.00280	.01100	.00260
1.600	-1.150	-.30200	.17970	.06550	-.00690	.04660	-.01540	.01110	.00250	.01030	.00260
1.600	-.150	-.29900	.17960	.06430	-.00600	.00360	-.00130	.00030	.00250	.01000	.00280
1.600	.860	-.30000	.17850	.06400	-.00520	-.04110	.01190	-.01020	.00240	.01010	.00290
1.600	1.860	-.30100	.17890	.06500	-.00510	-.07900	.02510	-.02070	.00250	.01020	.00280
1.600	2.870	-.30600	.17890	.06890	-.00510	-.12070	.03810	-.02970	.00350	.01090	.00280
1.600	3.880	-.30700	.17820	.06800	-.00490	-.16910	.05210	-.03770	.00390	.01100	.00280
1.600	5.880	-.30900	.17730	.06850	-.00450	-.24660	.07890	-.05530	.00510	.01220	.00310
1.600	7.900	-.30900	.17580	.06160	-.00430	-.32900	.09900	-.06450	.00530	.01030	.00270
GRADIENT		.00030	-.00022	-.00048	.00059	-.04194	.01338	-.00997	-.00001	-.00006	.00002

AMES 97-616 IAZ 01 TO S1 CMS,PC/PT=NOM,SRM A/A=8

(RBJ029) (23 JAN 73)

REFERENCE DATA

SREF = 3155.0000 SQ.FT. XMRP = 86.4167 FT.
 LREF = 50.8000 FT. YMRP = .0000 FT.
 BREF = 73.5000 FT. ZMRP = 4.0000 FT.
 SCALE = .0190

PARAMETRIC DATA

ALPHA = .000 ELEVON = .000
 AILRON = .000 RUDDER = .000
 PLUMES = 5.000

RUN NO. 6/ 0 RN/L = 2.54 GRADIENT INTERVAL = -5.00/ 5.00

MACH	BETA	CN	CAF	CLM	CWM	CY	CYN	CBL	CABORB	CABTNK	CABSRM
1.600	-4.160	-.12100	.16620	.07600	-.00760	.16880	-.05390	.04080	.00260	.00350	.00210
1.600	-3.170	-.12200	.16520	.07290	-.00630	.12870	-.04100	.03100	.00260	.00290	.00180
1.600	-2.160	-.12000	.16450	.07100	-.00470	.08970	-.02930	.02040	.00250	.00320	.00180
1.600	-1.150	-.11900	.16580	.06950	-.00350	.05050	-.01740	.01130	.00260	.00310	.00180
1.600	-.150	-.11700	.16450	.06710	-.00260	.00330	-.00140	-.00040	.00250	.00300	.00180
1.600	.860	-.11600	.16160	.06110	-.00150	-.03800	.01260	-.01110	.00110	.00220	.00140
1.600	1.870	-.11700	.16490	.06800	-.00120	-.07950	.02640	-.02050	.00250	.00240	.00160
1.600	2.880	-.12100	.16440	.06960	-.00040	-.11990	.03810	-.03000	.00260	.00220	.00160
1.600	3.880	-.12300	.16300	.06890	.00040	-.15940	.04960	-.03860	.00150	.00170	.00140
1.600	5.900	-.12500	.16300	.06790	.00190	-.24210	.07550	-.05730	.00220	.00340	.00160
1.600	7.920	-.12300	.16320	.05990	.00350	-.31740	.09640	-.06810	.00330	.00790	.00220
GRADIENT		.00007	-.00031	-.00100	.00097	-.04116	.01313	-.01000	-.00010	-.00020	-.00007

AMES 97-616 IA2 01 TO S1 OMS,PC/PT=NOM,SRM A/A=0

(RBJ030) (23 JAN 73)

REFERENCE DATA

SREF = 3155.0000 SQ.FT. XMRP = 86.4167 FT.
 LREF = 50.8000 FT. YMRP = .0000 FT.
 BREF = 73.5000 FT. ZMRP = 4.0000 FT.
 SCALE = .0190

PARAMETRIC DATA

ALPHA = 5.000 ELEVON = .000
 AILRON = .000 RUDDER = .000
 PLUMES = 5.000

RUN NO. 7/ 0 RN/L = 2.54 GRADIENT INTERVAL = -5.00/ 5.00

MACH	BETA	CN	CAF	CLM	CWM	CY	CYN	CBL	CABORB	CABTNK	CABSRM
1.600	-4.140	.08000	.15100	.03450	.00320	.15950	-.04830	.03510	.00280	-.00110	.00090
1.600	-3.150	.08600	.15230	.03610	.00440	.12040	-.03650	.02680	.00270	.00000	.00090
1.600	-2.150	.08500	.15300	.03610	.00590	.07740	-.02260	.01670	.00280	.00030	.00110
1.600	-1.150	.09200	.15510	.03470	.00700	.03960	-.01180	.00800	.00360	.00010	.00090
1.600	-.150	.09000	.15460	.03550	.00710	.00050	.00040	-.00070	.00360	.00060	.00100
1.600	.850	.08900	.15290	.03880	.00780	-.04070	.01290	-.00920	.00360	.00160	.00140
1.600	1.860	.09200	.15160	.03240	.00870	-.07660	.02380	-.01730	.00180	-.00020	.00090
1.600	2.850	.08800	.15100	.03260	.00960	-.11840	.03640	-.02730	.00210	.00020	.00090
1.600	3.860	.09300	.15080	.03180	.01030	-.15760	.04880	-.03690	.00270	.00090	.00100
1.600	5.860	.09200	.15120	.03010	.01180	-.24160	.07320	-.05340	.00350	.00280	.00130
1.600	7.870	.09400	.15110	.02630	.01250	-.32110	.09270	-.06610	.00420	.00360	.00150
	GRADIENT	.00062	-.00016	-.00041	.00084	-.03954	.01207	-.00892	-.00008	.00015	.00001

AMES 97-616 IA2 01 TO S1 M=.9 NOZ,PC/PT=.82 NOM

(RBJ031) (23 JAN 73)

REFERENCE DATA

SREF = 3155.0000 SQ.FT. XMRP = 86.4167 FT.
 LREF = 50.8000 FT. YMRP = .0000 FT.
 BREF = 73.5000 FT. ZMRP = 4.0000 FT.
 SCALE = .0190

PARAMETRIC DATA

BETA = .000 ELEVON = .000
 AILRON = .000 RUDDER = .000
 PLUMES = 2.000

RUN NO. 74/ 0 RN/L = 3.43 GRADIENT INTERVAL = -5.00/ 5.00

MACH	ALPHA	CN	CAF	CLM	CWM	CY	CYN	CBL	CABORB	CABTNK	CABSRM
1.600	-4.080	-.23200	.16750	.00880	-.00610	-.00020	-.00060	.00100	.00570	.01600	.00400
1.600	-2.070	-.16500	.16420	.03010	-.00680	.00360	-.00020	.00070	.00580	.01560	.00410
1.600	-1.050	-.12200	.16130	.02710	-.00460	.00280	-.00030	.00070	.00570	.01510	.00410
1.600	-.070	-.08400	.15910	.02440	-.00290	.00220	-.00050	.00090	.00550	.01440	.00400
1.600	.930	-.04300	.15680	.01760	-.00060	.00290	-.00040	.00080	.00540	.01410	.00400
1.600	1.960	-.00400	.15640	.01520	.00190	.00260	-.00010	.00030	.00620	.01730	.00450
1.600	3.990	.08300	.15430	-.00360	.00750	.00060	.00060	.00000	.00680	.01750	.00440
1.600	5.950	.16700	.14990	-.02620	.01250	-.00280	.00160	-.00070	.00700	.01680	.00430
1.600	7.960	.24700	.14560	-.02940	.01400	-.00580	.00170	-.00090	.00710	.01490	.00380
1.600	9.940	.32800	.14210	-.03310	.01650	-.00610	.00170	-.00310	.00560	.01230	.00310
	GRADIENT	.03925	-.00163	-.00211	.00179	.00003	.00012	-.00011	.00010	.00020	.00005

AMES 97-616 IA2 01 TO S1 M=.9 NOZ,PC/PT=1.1 NOM

(RBJ032) (23 JAN 73)

REFERENCE DATA

SREF = 3155.0000 SQ.FT. XMRP = 86.4167 FT.
 LREF = 50.8000 FT. YMRP = .0000 FT.
 BREF = 73.5000 FT. ZMRP = 4.0000 FT.
 SCALE = .0190

PARAMETRIC DATA

BETA = .000 ELEVON = .000
 AILRON = .000 RUDDER = .000
 PLUMES = 2.000

RUN NO. 75/ 0 RN/L = 2.71 GRADIENT INTERVAL = -5.00/ 5.00

MACH	ALPHA	CN	CAF	CLM	CWM	CY	CYN	CBL	CABORB	CABTNK	CABSRM
1.600	-4.100	-.22100	.16380	-.01000	-.00390	.00210	-.00090	.00100	.00350	.00890	.00250
1.600	-2.110	-.15700	.16000	.01440	-.00560	.00240	.00020	.00120	.00370	.00680	.00240
1.600	-1.030	-.11600	.15670	.01350	-.00350	.00260	-.00010	.00090	.00400	.00640	.00240
1.600	-.040	-.07900	.15510	.01170	-.00170	.00330	-.00050	.00110	.00410	.00660	.00240
1.600	.960	-.04000	.15210	.00740	.00040	.00230	-.00020	.00050	.00410	.00630	.00230
1.600	1.930	.00000	.15090	.00260	.00250	.00110	.00060	-.00020	.00390	.00570	.00220
1.600	3.970	.08400	.15170	-.01420	.00750	-.00120	.00140	.00000	.00490	.00650	.00220
1.600	5.940	.16300	.14790	-.03360	.01210	-.00340	.00230	-.00050	.00510	.00610	.00200
1.600	7.990	.24100	.14310	-.02710	.01300	-.00630	.00210	-.00100	.00510	.00530	.00170
1.600	9.990	.30500	.13920	-.01200	.01240	-.00710	.00190	-.00160	.00300	.00350	.00140
	GRADIENT	.03801	-.00168	-.00109	.00155	-.00038	.00023	-.00017	.00014	-.00028	-.00004

AMES 97-616 IA2 01 TO S1 M=3.0 NOZ,PC/PT=NOM

(RBJ033) (23 JAN 73)

REFERENCE DATA

SREF = 3155.0000 SQ.FT. XMRP = 86.4167 FT.
 LREF = 50.8000 FT. YMRP = .0000 FT.
 BREF = 73.5000 FT. ZMRP = 4.0000 FT.
 SCALE = .0190

PARAMETRIC DATA

BETA = .000 ELEVON = .000
 AILRON = .000 RUDDER = .000
 PLUMES = 2.000

RUN NO. 76/ 0 RN/L = 1.82 GRADIENT INTERVAL = -5.00/ 5.00

MACH	ALPHA	CN	CAF	CLM	CWM	CY	CYN	CBL	CABORB	CABTNK	CABSRM
1.600	-3.990	-.19100	.15130	-.03840	.00330	-.00870	.00510	-.00070	-.00490	-.01470	-.00250
1.600	-2.030	-.13600	.14520	-.01350	.00000	-.00870	.00560	-.00100	-.00590	-.01690	-.00320
1.600	-.960	-.10300	.14270	-.00610	.00000	-.00820	.00520	-.00010	-.00570	-.01800	-.00330
1.600	-.040	-.07000	.14030	-.00010	.00040	-.00800	.00500	-.00020	-.00570	-.01900	-.00330
1.600	.990	-.03700	.13820	.00050	.00180	-.00970	.00520	-.00010	-.00560	-.01940	-.00350
1.600	2.040	-.00100	.13550	-.00060	.00350	-.00950	.00530	-.00050	-.00520	-.01850	-.00350
1.600	3.960	.07800	.13200	-.01450	.00740	-.01190	.00620	-.00060	-.00530	-.02040	-.00360
1.600	6.000	.14500	.12690	-.01310	.00810	-.01360	.00690	-.00010	-.00550	-.01950	-.00360
1.600	8.040	.21100	.11390	-.01120	.00880	-.01490	.00440	-.00060	-.00580	-.02110	-.00370
1.600	10.010	.27500	.10540	-.00600	.00940	-.01620	.00550	-.00120	-.00780	-.02190	-.00390
	GRADIENT	.03370	-.00241	.00306	.00060	-.00038	.00009	.00003	-.00000	-.00065	-.00012

AMES 97-616 IA2 01 TO S1 M=3.0 NOZ,PC/PT=1.2 NOM

(RBJ034) (23 JAN 73)

REFERENCE DATA

SREF = 3155.0000 SQ.FT. XMRP = 86.4167 FT.
 LREF = 50.8000 FT. YMRP = .0000 FT.
 BREF = 73.5000 FT. ZMRP = 4.0000 FT.
 SCALE = .0190

PARAMETRIC DATA

BETA = .000 ELEVON = .000
 AILRON = .000 RUDDER = .000
 PLUMES = 2.000

RUN NO. 79/ 0 RN/L = 1.78 GRADIENT INTERVAL = -5.00/ 5.00

MACH	ALPHA	CN	CAF	CLM	CWB	CY	CYN	CBL	CABOR	CABTNK	CABSRM
1.600	-4.060	-.18600	.14740	-.05110	.00450	-.01160	.00610	-.00030	-.00880	-.02100	-.00410
1.600	-2.070	-.12900	.14010	-.02600	.00130	-.01090	.00720	-.00110	-.00940	-.02260	-.00500
1.600	-1.010	-.09500	.13670	-.02050	.00060	-.01020	.00600	-.00010	-.00930	-.02290	-.00500
1.600	-.030	-.06100	.13490	-.01400	.00130	-.00940	.00570	.00020	-.00900	-.02500	-.00500
1.600	.980	-.03200	.13250	-.00780	.00250	-.00900	.00590	-.00010	-.00890	-.02700	-.00520
1.600	1.990	.00300	.13010	-.00830	.00420	-.01110	.00640	-.00040	-.00860	-.02660	-.00540
1.600	3.970	.07900	.12650	-.02050	.00810	-.01200	.00660	-.00060	-.00840	-.02860	-.00560
1.600	6.000	.13900	.12330	-.00970	.00870	-.01390	.00740	-.00020	-.00860	-.02740	-.00530
1.600	8.000	.19600	.11540	.00060	.00820	-.01370	.00450	-.00030	-.00940	-.02950	-.00580
1.600	10.000	.25900	.09920	.00740	.00870	-.01490	.00430	-.00090	-.01070	-.02980	-.00570
	GRADIENT	.03284	-.00255	.00405	.00052	-.00002	.00001	.00001	.00009	-.00101	-.00017

AMES 97-616 IA2 01 TO S1 M=3.0 NOZ,PC/PT=0.8 NOM

(RBJ035) (23 JAN 73)

REFERENCE DATA

SREF = 3155.0000 SQ.FT. XMRP = 86.4167 FT.
 LREF = 50.8000 FT. YMRP = .0000 FT.
 BREF = 73.5000 FT. ZMRP = 4.0000 FT.
 SCALE = .0190

PARAMETRIC DATA

BETA = .000 ELEVON = .000
 AILRON = .000 RUDDER = .000
 PLUMES = 2.000

RUN NO. 80/ 0 RN/L = 1.74 GRADIENT INTERVAL = -5.00/ 5.00

MACH	ALPHA	CN	CAF	CLM	CWB	CY	CYN	CBL	CABOR	CABTNK	CABSRM
1.600	-3.990	-.20500	.15660	-.01720	.00050	-.00730	.00360	.00030	-.00150	-.00490	-.00020
1.600	-1.990	-.14600	.15080	.00140	-.00160	-.00920	.00520	-.00040	-.00290	-.00980	-.00150
1.600	-1.000	-.11000	.14810	.00780	-.00120	-.00770	.00440	.00010	-.00240	-.00960	-.00150
1.600	-.010	-.07600	.14580	.00770	.00010	-.00720	.00450	-.00010	-.00250	-.01100	-.00160
1.600	1.000	-.03700	.14300	.00730	.00150	-.00830	.00450	-.00060	-.00260	-.01090	-.00150
1.600	2.000	-.00400	.14090	.00440	.00320	-.00920	.00320	-.00050	-.00260	-.01050	-.00150
1.600	4.020	.07400	.13670	-.00720	.00730	-.01050	.00600	-.00110	-.00250	-.01170	-.00160
1.600	6.000	.14400	.13320	-.00940	.00920	-.01360	.00690	-.00120	-.00270	-.01200	-.00190
1.600	8.020	.21200	.12690	-.00670	.00940	-.01670	.00600	-.00030	-.00320	-.01270	-.00180
1.600	10.020	.26300	.10970	-.00910	.00990	-.01650	.00560	-.00080	-.00320	-.01330	-.00210
	GRADIENT	.03506	-.00249	.00107	.00094	-.00032	.00023	-.00015	-.00009	-.00071	-.00013

AMES 97-616 IAS 01 TO S1 NO PLUMES

(RBJ501) (25 JAN 73)

REFERENCE DATA

SREF = 3135.0000 SQ.FT. XMRP = 86.4167 FT.
 LREF = 50.8000 FT. YMRP = .0000 FT.
 BREF = 73.5000 FT. ZMRP = 4.0000 FT.
 SCALE = .0190

PARAMETRIC DATA

BETA = .000 ELEVON = .000
 AILRON = .000 RUDDER = .000
 PLUMES = .000

RUN NO. 502/ 0 RN/L = 2.54 GRADIENT INTERVAL = -5.00/ 5.00

MACH	ALPHA	CN	CAF	CLM	CWBM	CY	CYN	CBL	CABORB	CABTNK	CABSRM
1.600	-3.910	-.27000	.18410	.09500	-.01270	.00230	-.00060	.00130	.01640	.04190	.01090
1.600	-2.920	-.22800	.18160	.08560	-.01060	.00400	-.00080	.00070	.01640	.04190	.01090
1.600	-1.930	-.18800	.17860	.07980	-.00850	.00370	-.00050	.00010	.01670	.04210	.01080
1.600	-.930	-.14100	.17540	.07080	-.00580	.00390	-.00020	.00070	.01700	.04240	.01080
1.600	.070	-.09900	.17220	.06270	-.00360	.00490	-.00140	.00060	.01740	.04250	.01080
1.600	1.040	-.05600	.16990	.05190	-.00100	.00390	-.00080	.00080	.01740	.04130	.01050
1.600	2.060	-.01400	.16820	.04160	.00180	.00280	-.00030	.00100	.01750	.04030	.01030
1.600	3.110	.02700	.16530	.03050	.00440	.00140	.00050	.00000	.01770	.03970	.01020
1.600	4.060	.07200	.16320	.01790	.00700	.00200	.00060	-.00070	.01780	.03970	.01020
1.600	6.040	.15700	.15660	-.00710	.01210	-.00150	.00170	-.00090	.01850	.04130	.01060
1.600	8.050	.25300	.15590	-.03300	.01700	-.00300	.00140	-.00130	.01810	.04050	.01030
1.600	10.060	.34500	.15290	-.05440	.02080	-.00690	.00200	-.00160	.01710	.03990	.01010
	GRADIENT	.04282	-.00266	-.00950	.00249	-.00018	.00014	-.00014	.00019	-.00034	-.00010

RUN NO. 531/ 0 RN/L = 2.07 GRADIENT INTERVAL = -5.00/ 5.00

MACH	ALPHA	CN	CAF	CLM	CWBM	CY	CYN	CBL	CABORB	CABTNK	CABSRM
1.985	-3.580	-.25700	.17700	.07940	-.00880	-.00260	.00080	.00030	.01340	.03530	.00910
1.985	-1.600	-.17300	.16980	.06340	-.00560	-.00230	.00090	.00040	.01310	.03430	.00870
1.985	-.570	-.13100	.16620	.05510	-.00410	-.00120	.00040	.00050	.01310	.03340	.00860
1.985	.400	-.09200	.16330	.04680	-.00190	-.00190	.00090	.00060	.01300	.03310	.00840
1.985	1.430	-.05100	.16170	.03870	.00040	-.00200	.00100	.00020	.01300	.03230	.00820
1.985	2.420	-.00900	.16000	.03180	.00290	-.00380	.00170	.00010	.01300	.03160	.00800
1.985	4.430	.07400	.15690	.01960	.00760	-.00490	.00240	-.00010	.01310	.02980	.00760
1.985	6.430	.15200	.15480	.01010	.01110	-.00650	.00270	-.00030	.01330	.02940	.00760
1.985	8.420	.23400	.15190	.00300	.01370	-.00880	.00320	-.00110	.01400	.03000	.00770
1.985	10.400	.32200	.14880	-.00960	.01630	-.00790	.00300	-.00070	.01450	.03030	.00770
	GRADIENT	.04116	-.00248	-.00758	.00207	-.00031	.00020	-.00006	-.00004	-.00068	-.00019

AMES 97-616 IA2 O1 TO S1 NO FLUMES

(RBJ501) (23 JAN 73)

REFERENCE DATA

SREF = 3155.0000 SQ.FT. XMRP = 86.4167 FT.
 LREF = 30.8000 FT. YMRP = .0000 FT.
 BREF = 73.5000 FT. ZMRP = 4.0000 FT.
 SCALE = .0190

PARAMETRIC DATA

BETA = .000 ELEVON = .000
 AILRON = .000 RUDDER = .000
 PLUMES = .000

RUN NO. 344/ D RN/L = 1.73 GRADIENT INTERVAL = -5.00/ 5.00

MACH	ALPHA	CN	CAF	CLM	CWM	CY	CYN	CBL	CABORB	CABTNK	CABSRM
2.170	-3.310	-.24800	.17480	.07490	-.00680	-.00530	.00100	.00040	.01230	.03330	.00940
2.170	-1.310	-.15900	.16900	.06080	-.00400	-.00380	.00040	.00060	.01200	.03120	.00790
2.170	-.280	-.11500	.16470	.05410	-.00200	-.00390	.00070	.00040	.01220	.03090	.00780
2.170	.680	-.07100	.16140	.04640	-.00020	-.00340	.00100	.00020	.01210	.03030	.00760
2.170	1.680	-.03100	.15830	.03920	.00160	-.00400	.00150	.00000	.01210	.02950	.00750
2.170	2.720	.01200	.15530	.03030	.00350	-.00490	.00160	.00010	.01200	.02820	.00720
2.170	4.700	.09400	.15110	.01380	.00720	-.00490	.00230	.00010	.01180	.02670	.00680
2.170	6.660	.16900	.14790	.00400	.01000	-.00820	.00320	-.00020	.01210	.02690	.00690
2.170	8.730	.24100	.14670	.00340	.01180	-.01130	.00410	-.00120	.01180	.02570	.00660
2.170	10.720	.32300	.14520	-.00310	.01380	-.01160	.00400	-.00110	.01210	.02610	.00660
	GRADIENT	.04265	-.00306	-.00762	.00177	-.00002	.00020	-.00006	-.00005	-.00080	-.00019

AMES 97-618 IA2 01 TO S1 NO PLUMES

(RBJ502) (23 JAN 73)

REFERENCE DATA

SREF = 3155.0000 SQ.FT. XMRP = 86.4167 FT.
 LREF = 50.8000 FT. YMRP = .0000 FT.
 BREF = 73.5000 FT. ZMRP = 4.0000 FT.
 SCALE = .0190

PARAMETRIC DATA

ALPHA = .000 ELEVON = .000
 AILRON = .000 RUDDER = .000
 PLUMES = .000

RUN NO. 503/ 0 RN/L = 2.52 GRADIENT INTERVAL = -5.00/ 5.00

MACH	BETA	CN	CAF	CLM	CWM	CY	CYN	CBL	CABCRB	CABTNK	CABSRM
1.600	-4.180	-.11100	.17280	.06540	-.00850	.17690	-.05680	.04330	.01810	.04070	.01060
1.600	-3.170	-.11200	.17440	.06720	-.00740	.13510	-.04310	.03340	.01740	.04030	.01040
1.600	-2.160	-.11300	.17370	.06740	-.00630	.09100	-.02950	.02330	.01710	.04130	.01050
1.600	-1.150	-.11100	.17390	.06650	-.00490	.04990	-.01610	.01250	.01700	.04140	.01050
1.600	-.140	-.11100	.17310	.06590	-.00410	.00470	-.00140	.00160	.01700	.04190	.01060
1.600	.860	-.11100	.17330	.06460	-.00290	-.03620	.01280	-.01000	.01700	.04120	.01060
1.600	1.870	-.11300	.17370	.06590	-.00190	-.07840	.02610	-.02030	.01730	.04120	.01070
1.600	2.880	-.11200	.17440	.06670	-.00070	-.12040	.03910	-.03050	.01760	.04110	.01070
1.600	3.890	-.11600	.17420	.06740	.00030	-.16470	.05360	-.04050	.01850	.04120	.01070
1.600	5.900	-.11400	.17370	.06450	.00210	-.24810	.08120	-.06000	.01930	.04130	.01070
	GRADIENT	-.00033	.00008	.00003	.00109	-.04228	.01369	-.01052	.00004	.00007	.00003

RUN NO. 534/ 0 RN/L = 2.07 GRADIENT INTERVAL = -5.00/ 5.00

MACH	BETA	CN	CAF	CLM	CWM	CY	CYN	CBL	CABCRB	CABTNK	CABSRM
1.985	-4.130	-.10200	.16540	.04950	-.00570	.15980	-.05850	.03660	.01410	.03370	.00850
1.985	-2.110	-.10100	.16510	.04940	-.00360	.08120	-.03030	.01960	.01350	.03330	.00850
1.985	-1.110	-.10100	.16470	.04960	-.00310	.04130	-.01540	.01050	.01330	.03320	.00850
1.985	-.110	-.10300	.16380	.05050	-.00220	-.00090	.00060	.00090	.01330	.03370	.00860
1.985	.900	-.10300	.16420	.05070	-.00150	-.04440	.01670	-.00890	.01340	.03390	.00860
1.985	1.900	-.10400	.16460	.05120	-.00040	-.08730	.03280	-.01870	.01360	.03350	.00870
1.985	3.910	-.10500	.16580	.05230	.00130	-.16840	.06190	-.03600	.01410	.03400	.00880
1.985	5.930	-.10700	.16630	.05360	.00310	-.24870	.08960	-.05160	.01450	.03450	.00880
	GRADIENT	-.00047	.00000	.00038	.00085	-.04113	.01517	-.00916	.00001	.00005	.00004

RUN NO. 547/ 0 RN/L = 1.74 GRADIENT INTERVAL = -5.00/ 5.00

MACH	BETA	CN	CAF	CLM	CWM	CY	CYN	CBL	CABCRB	CABTNK	CABSRM
2.171	-4.140	-.07700	.16350	.04610	-.00330	.15170	-.05350	.03230	.01260	.03100	.00780
2.171	-2.140	-.07700	.16240	.04570	-.00190	.07640	-.02770	.01740	.01230	.03020	.00760
2.171	-1.130	-.07700	.16210	.04620	-.00130	.03730	-.01350	.00890	.01220	.03000	.00760
2.171	-.130	-.07700	.16190	.04640	-.00060	-.00050	.00020	.00080	.01210	.02980	.00760
2.171	.870	-.07800	.16270	.04710	.00020	-.04410	.01580	-.00630	.01210	.03000	.00760
2.171	1.870	-.07800	.16290	.04730	.00090	-.08360	.02990	-.01660	.01220	.03020	.00770
2.171	3.880	-.08100	.16400	.04970	.00250	-.15970	.05600	-.03190	.01240	.03090	.00790
2.171	5.890	-.08100	.16550	.05160	.00390	-.23570	.08120	-.04620	.01280	.03110	.00790
	GRADIENT	-.00045	.00009	.00044	.00072	-.03912	.01384	-.00812	-.00003	-.00001	.00001

AMES 97-616 IA2 01 TO S1 NO PLUMES

(RBJ524) (23 JAN 73)

REFERENCE DATA

SREF = 3155.0000 SQ.FT. XMRP = 86.4167 FT.
 LREF = 50.8000 FT. YMRP = .0000 FT.
 BREF = 73.5000 FT. ZMRP = 4.0000 FT.
 SCALE = .0190

PARAMETRIC DATA

ALPHA = -5.000 ELEVON = .000
 AILRON = .000 RUDDER = .000
 PLUMES = .000

RUN NO. 533/ 0 RN/L = 2.07 GRADIENT INTERVAL = -5.00/ 5.00

MACH	BETA	CN	CAF	CLM	CMBM	CY	CYN	CBL	CABORB	CABTNK	CABSRM
1.985	-4.110	-.31300	.18220	.09330	-.01360	.16410	-.05920	.03390	.01390	.03610	.00910
1.985	-2.110	-.31600	.18180	.09460	-.01230	.08550	-.03140	.01810	.01370	.03670	.00930
1.985	-1.120	-.31700	.18100	.09520	-.01160	.04120	-.01560	.00930	.01370	.03680	.00940
1.985	-.110	-.31600	.18020	.09450	-.01090	-.00160	.00030	.00050	.01370	.03700	.00940
1.985	.890	-.31900	.18040	.09560	-.01000	-.04500	.01630	-.00830	.01380	.03710	.00950
1.985	1.900	-.31800	.18040	.09620	-.00920	-.08690	.03130	-.01680	.01400	.03730	.00960
1.985	3.900	-.32100	.18100	.09680	-.00810	-.16910	.06000	-.03260	.01440	.03820	.00970
1.985	5.910	-.32500	.18190	.09780	-.00670	-.25050	.08690	-.04670	.01450	.03800	.00960
	GRADIENT	-.00090	-.00019	.00042	.00071	-.04193	.01507	-.00840	.00006	.00024	.00007

AMES 97-616 IA2 01 TO S1 NO PLUMES

(RBJ525) (23 JAN 73)

REFERENCE DATA

SREF = 3155.0000 SQ.FT. XMRP = 86.4167 FT.
 LREF = 50.8000 FT. YMRP = .0000 FT.
 BREF = 73.5000 FT. ZMRP = 4.0000 FT.
 SCALE = .0190

PARAMETRIC DATA

ALPHA = 5.000 ELEVON = .000
 AILRON = .000 RUDDER = .000
 PLUMES = .000

RUN NO. 535/ 0 RN/L = 2.08 GRADIENT INTERVAL = -5.00/ 5.00

MACH	BETA	CN	CAF	CLM	CMBM	CY	CYN	CBL	CABORB	CABTNK	CABSRM
1.985	-4.100	.11000	.15630	.01740	.00590	.15670	-.05630	.03580	.01380	.03090	.00790
1.985	-2.100	.11000	.15650	.01640	.00800	.07580	-.02680	.01780	.01350	.03030	.00770
1.985	-1.110	.11000	.15660	.01580	.00890	.03460	-.01240	.00920	.01340	.03010	.00770
1.985	-.110	.10900	.15610	.01610	.00930	-.00570	.00260	-.00040	.01330	.03000	.00760
1.985	.890	.10900	.15580	.01630	.01030	-.04490	.01690	-.00940	.01340	.03020	.00760
1.985	1.890	.11000	.15600	.01670	.01140	-.08460	.03140	-.01840	.01380	.03060	.00780
1.985	3.890	.10600	.15640	.01920	.01270	-.16590	.06130	-.03700	.01420	.03060	.00790
1.985	5.880	.10500	.15630	.01990	.01350	-.24880	.09070	-.05360	.01450	.03170	.00810
	GRADIENT	-.00041	-.00003	.00020	.00084	-.04031	.01469	-.00911	.00005	-.00001	.00000

AMES 97-616 IA2 01 TO 51 NO PLUMES

(RBJ511) (23 JAN 73)

REFERENCE DATA

SREF = 3155.0000 SQ.FT. XMRP = 86.4167 FT.
 LREF = 50.8000 FT. YMRP = .0000 FT.
 BREF = 73.5000 FT. ZMRP = 4.0000 FT.
 SCALE = .0190

PARAMETRIC DATA

BETA = .000 ELEVON = 10.000
 AILRON = .000 RUDDER = 10.000
 PLUMES = .000

RUN NO. 516/ 0 RN/L = 2.60 GRADIENT INTERVAL = -5.00/ 5.00

MACH	ALPHA	CN	CAF	CLM	CWM	CY	CYN	CBL	CABORB	CABTNK	CABSRM
1.600	-3.870	-.21500	.19020	.02390	-.00710	.01980	-.01870	.00970	.01700	.04010	.01050
1.600	-1.940	-.13200	.16410	.00910	-.00230	.01760	-.01780	.00990	.01760	.04020	.01040
1.600	-.950	-.09200	.18130	.00130	.00020	.02090	-.01820	.01010	.01810	.03990	.01020
1.600	.080	-.04800	.17850	-.00600	.00250	.01810	-.01760	.00910	.01830	.03930	.01000
1.600	1.060	-.00900	.17600	-.01500	.00510	.01780	-.01720	.00950	.01890	.03840	.00980
1.600	2.050	.03600	.17360	-.02620	.00770	.01750	-.01690	.00820	.01930	.03760	.00960
1.600	4.000	.11900	.16960	-.04640	.01330	.01350	-.01490	.00790	.01990	.03640	.00930
1.600	6.070	.21000	.16640	-.07260	.01850	.01310	-.01440	.00680	.01950	.03630	.00920
1.600	8.050	.29800	.16360	-.09570	.02380	.00900	-.01400	.00700	.02020	.03560	.00900
1.600	10.070	.39200	.16010	-.11220	.02750	.00730	-.01350	.00600	.01890	.03440	.00870
	GRADIENT	.04232	-.00262	-.00888	.00257	-.00069	.00043	-.00027	.00037	-.00052	-.00016

RUN NO. 548/ 0 RN/L = 2.08 GRADIENT INTERVAL = -5.00/ 5.00

MACH	ALPHA	CN	CAF	CLM	CWM	CY	CYN	CBL	CABORB	CABTNK	CABSRM
1.985	-3.600	-.21600	.18260	.03490	-.00440	.01020	-.01310	.00730	.01380	.03470	.00890
1.985	-1.560	-.12600	.17540	.01430	-.00120	.01020	-.01240	.00690	.01370	.03280	.00840
1.985	-.590	-.08500	.17220	.00380	.00080	.00970	-.01230	.00670	.01350	.03200	.00820
1.985	.430	-.04300	.16970	-.00640	.00300	.01040	-.01250	.00710	.01350	.03110	.00790
1.985	1.420	-.00300	.16800	-.01560	.00530	.00960	-.01210	.00670	.01350	.03000	.00770
1.985	2.430	.03900	.16580	-.02430	.00790	.00970	-.01210	.00670	.01360	.02890	.00730
1.985	4.420	.11800	.16350	-.03480	.01230	.00890	-.01130	.00620	.01350	.02670	.00680
1.985	6.390	.19100	.16100	-.04000	.01530	.00660	-.01020	.00560	.01370	.02600	.00660
1.985	8.430	.27000	.15880	-.04440	.01800	.00420	-.00970	.00530	.01420	.02580	.00660
1.985	10.440	.35800	.15650	-.05390	.02040	.00470	-.00980	.00490	.01440	.02500	.00630
	GRADIENT	.04155	-.00237	-.00893	.00213	-.00015	.00019	-.00011	-.00003	-.00099	-.00026

RUN NO. 558/ 0 RN/L = 1.72 GRADIENT INTERVAL = -5.00/ 5.00

MACH	ALPHA	CN	CAF	CLM	CWM	CY	CYN	CBL	CABORB	CABTNK	CABSRM
2.171	-3.310	-.21300	.17810	.03240	-.00330	.00910	-.01160	.00610	.01250	.03220	.00800
2.171	-1.340	-.12500	.17140	.01850	-.00050	.00980	-.01150	.00610	.01280	.03040	.00770
2.171	-.330	-.08100	.16880	.01090	.00140	.00930	-.01110	.00600	.01250	.02950	.00750
2.171	.690	-.03800	.16600	.00250	.00340	.00990	-.01080	.00600	.01240	.02850	.00720
2.171	1.670	.00900	.16270	-.00620	.00520	.00980	-.01040	.00550	.01240	.02770	.00700
2.171	2.660	.04200	.15970	-.01370	.00700	.00970	-.01050	.00500	.01220	.02680	.00670
2.171	4.680	.12400	.15560	-.02970	.01060	.00830	-.00960	.00510	.01200	.02480	.00620
2.171	6.680	.19900	.15320	-.03680	.01360	.00590	-.00840	.00500	.01210	.02390	.00600
2.171	8.680	.26900	.15190	-.03530	.01520	.00190	-.00690	.00400	.01200	.02300	.00580
2.171	10.660	.35000	.15140	-.03930	.01690	.00150	-.00680	.00390	.01200	.02230	.00550
	GRADIENT	.04213	-.00285	-.00786	.00177	-.00007	.00026	-.00016	-.00008	-.00092	-.00023

AMES 97-616 IAZ 01 TO S1 NO PLUMES

(RBJ512) (23 JAN 73)

REFERENCE DATA

SREF = 3155.0000 SQ.FT. XMRP = 86.4167 FT.
 LREF = 50.8000 FT. YMRP = .0000 FT.
 BREF = 73.5000 FT. ZMRP = 4.0000 FT.
 SCALE = .0190

PARAMETRIC DATA

ALPHA = .000 ELEVON = 10.000
 AILRON = .000 RUDDER = 10.000
 PLUMES = .000

RUN NO. 517/ 0 RN/L = 2.55 GRADIENT INTERVAL = -5.00/ 5.00

MACH	BETA	CN	CAF	CLM	CWM	CY	CYN	CBL	CABORB	CABTNK	CABSRM
1.600	-4.170	-.06000	.17950	-.00250	-.00260	.18710	-.07160	.05130	.01940	.03980	.01030
1.600	-2.150	-.06200	.17900	-.00170	-.00030	.10460	-.04540	.03080	.01910	.03940	.01020
1.600	-1.150	-.06300	.17900	-.00180	.00090	.06340	-.03220	.02100	.01900	.03960	.01010
1.600	-.140	-.06000	.17870	-.00290	.00200	.01880	-.01770	.00980	.01880	.04000	.01020
1.600	.870	-.06100	.17870	-.00310	.00310	-.02370	-.00350	-.00090	.01840	.03930	.01020
1.600	1.870	-.06300	.17900	-.00200	.00420	-.06290	.00920	-.01160	.01840	.03930	.01030
1.600	3.890	-.06200	.17910	-.00300	.00640	-.14830	.03680	-.03070	.01890	.03990	.01040
1.600	5.900	-.06300	.17780	-.00650	.00850	-.23310	.06690	-.05230	.02060	.04040	.01050
	GRADIENT	-.00019	-.00004	-.00009	.00112	-.04170	.01351	-.01028	-.00009	-.00000	.00002

RUN NO. 549/ 0 RN/L = 2.08 GRADIENT INTERVAL = -5.00/ 5.00

MACH	BETA	CN	CAF	CLM	CWM	CY	CYN	CBL	CABORB	CABTNK	CABSRM
1.985	-4.110	-.06400	.17060	.00230	-.00140	.17620	-.07260	.04320	.01470	.03260	.00830
1.985	-2.110	-.06400	.16950	.00160	.00050	.09390	-.04300	.02550	.01420	.03230	.00820
1.985	-1.120	-.06400	.16890	.00210	.00110	.05490	-.02870	.01680	.01410	.03220	.00820
1.985	-.100	-.06300	.16920	.00180	.00190	.01260	-.01300	.00720	.01370	.03190	.00820
1.985	.900	-.06500	.16900	.00160	.00290	-.03080	.00340	-.00290	.01380	.03210	.00820
1.985	1.900	-.06500	.16890	.00130	.00400	-.07220	.01930	-.01270	.01390	.03210	.00820
1.985	3.920	-.06600	.16920	.00180	.00570	-.15510	.05020	-.03120	.01440	.03260	.00840
1.985	5.930	-.06800	.16940	.00180	.00760	-.23540	.07810	-.04720	.01480	.03280	.00830
	GRADIENT	-.00026	-.00016	-.00007	.00088	-.04135	.01537	-.00934	-.00005	-.00001	.00001

RUN NO. 559/ 0 RN/L = 1.73 GRADIENT INTERVAL = -5.00/ 5.00

MACH	BETA	CN	CAF	CLM	CWM	CY	CYN	CBL	CABORB	CABTNK	CABSRM
2.171	-4.150	-.04500	.16750	.00440	.00010	.16550	-.06590	.03820	.01280	.02940	.00740
2.171	-2.140	-.04500	.16590	.00340	.00150	.09000	-.03940	.02250	.01280	.02930	.00730
2.171	-1.130	-.04400	.16570	.00290	.00220	.05050	-.02560	.01430	.01280	.02910	.00730
2.171	-.130	-.04400	.16520	.00350	.00310	.01110	-.01120	.00600	.01270	.02910	.00730
2.171	.880	-.04500	.16610	.00420	.00400	-.03150	.00420	-.00320	.01250	.02870	.00730
2.171	1.880	-.04300	.16620	.00360	.00480	-.07040	.01860	-.01190	.01260	.02870	.00730
2.171	3.890	-.04500	.16730	.00500	.00630	-.14760	.04540	-.02780	.01270	.02900	.00730
2.171	5.890	-.04600	.16840	.00670	.00790	-.22290	.07030	-.04250	.01290	.02910	.00730
	GRADIENT	.00007	.00000	.00010	.00079	-.03921	.01400	-.00830	-.00003	-.00008	-.00001

REFERENCE DATA

SREF = 3155.0000 SQ.FT. XMRP = 86.4167 FT.
 LREF = 50.0000 FT. YMRP = .0000 FT.
 BREF = 73.5000 FT. ZMRP = 4.0000 FT.
 SCALE = .0190

PARAMETRIC DATA

BETA = .000 ELEVON = -10.000
 AIRLON = .000 RUDDER = 10.000
 PLUMES = .000

RUN NO. 529/ 0 RN/L = 2.61 GRADIENT INTERVAL = -5.00/ 5.00

MACH	ALPHA	CN	CAF	CLM	CWCM	CY	CYN	CBL	CABORB	CABTNK	CABSRM
1.600	-3.920	-.31200	.19500	.16870	-.01870	.01580	-.01690	.01060	.01690	.04480	.01150
1.600	-1.940	-.22900	.19440	.15600	-.01380	.01690	-.01660	.01010	.01510	.04180	.01060
1.600	-.920	-.18800	.18900	.14930	-.01170	.01720	-.01650	.01030	.01560	.04300	.01080
1.600	.080	-.14400	.18510	.13970	-.00940	.01470	-.01620	.00970	.01550	.04240	.01070
1.600	1.090	-.10100	.18110	.12790	-.00670	.01590	-.01620	.00930	.01560	.04200	.01070
1.600	2.070	-.06300	.17870	.11910	-.00420	.01300	-.01510	.00890	.01550	.04170	.01060
1.600	4.040	.02700	.17370	.09520	.00140	.01070	-.01410	.00730	.01580	.04050	.01040
1.600	6.070	.11500	.16830	.06780	.00680	.00740	-.01280	.00710	.01590	.04170	.01070
1.600	8.040	.20900	.16370	.04040	.01160	.00660	-.01330	.00670	.01620	.04250	.01090
1.600	10.050	.30200	.15960	.01670	.01540	.00380	-.01290	.00610	.01460	.04210	.01070
GRADIENT		.04239	-.00298	-.00029	.000250	-.000070	.000035	-.000040	-.000009	-.000044	-.000011

RUN NO. 564/ 0 RN/L = 2.11 GRADIENT INTERVAL = -5.00/ 5.00

MACH	ALPHA	CN	CAF	CLM	CWCM	CY	CYN	CBL	CABORB	CABTNK	CABSRM
1.985	-3.510	-.29800	.18630	.13760	-.01320	.00760	-.01180	.00750	.01280	.03700	.00940
1.985	-1.660	-.21600	.17900	.12280	-.01030	.00820	-.01120	.00750	.01300	.03600	.00920
1.985	-.520	-.17000	.17500	.11380	-.00820	.00860	-.01130	.00750	.01290	.03470	.00890
1.985	.360	-.13000	.17250	.10470	-.00640	.00870	-.01140	.00750	.01260	.03370	.00860
1.985	1.400	-.08900	.16940	.09630	-.00410	.00780	-.01080	.00720	.01230	.03330	.00850
1.985	2.440	-.04700	.16730	.08800	-.00160	.00670	-.01060	.00710	.01190	.03240	.00830
1.985	4.380	.03400	.16400	.07470	.00330	.00600	-.00950	.00630	.01170	.03100	.00790
1.985	6.340	.11500	.16020	.06340	.00670	.00340	-.00920	.00610	.01200	.03080	.00790
1.985	8.420	.19800	.15690	.05390	.00980	.00330	-.00920	.00570	.01260	.03130	.00800
1.985	10.410	.28900	.15340	.03930	.01250	.00110	-.00840	.00530	.01330	.03180	.00810
GRADIENT		.04190	-.00283	-.000813	.000210	-.000025	.000026	-.000014	-.000017	-.000078	-.000020

DATE 25 OCT 73

TABULATED SOURCE DATA, ARC 97-616

PAGE 37

AMES 97-616 1A2 01 TO S1 NO PLUMES

(RBJ522) (23 JAN 73)

REFERENCE DATA

SREF = 3155.0000 SQ.FT. XMRP = 86.4167 FT.
 LREF = 50.8000 FT. YMRP = .0000 FT.
 BREF = 73.5000 FT. ZMRP = 4.0000 FT.
 SCALE = .0190

PARAMETRIC DATA

BETA = .000 ELEVON = .000
 AILRON = 10.000 RUDDER = .000
 PLUMES = .000

RUN NO. 561/ 0 RN/L = 2.09 GRADIENT INTERVAL = -5.00/ 5.00

MACH	ALPHA	CN	CAF	CLM	CWM	CY	CYN	CBL	CABORB	CABTNK	CABSRM
1.984	-3.580	-.25200	.18630	.08370	-.01310	.00270	-.00190	.01090	.01270	.03410	.00870
1.984	-1.590	-.16100	.17910	.06410	-.00990	.00360	-.00200	.01120	.01260	.03260	.00830
1.984	-.570	-.11800	.17550	.05400	-.00810	.00440	-.00230	.01120	.01250	.03170	.00800
1.984	.410	-.07700	.17280	.04350	-.00600	.00460	-.00270	.01140	.01210	.03060	.00770
1.984	1.360	-.03900	.17080	.03450	-.00350	.00330	-.00240	.01130	.01210	.02980	.00750
1.984	2.350	.00400	.16830	.02500	-.00110	.00350	-.00280	.01090	.01210	.02900	.00720
1.984	4.380	.08700	.16530	.01060	.00380	.00270	-.00250	.01020	.01200	.02740	.00680
1.984	6.430	.16400	.16300	.00310	.00730	-.00120	-.00130	.00980	.01220	.02650	.00660
1.984	8.430	.24000	.16000	-.00180	.01000	-.00440	-.00090	.00900	.01270	.02660	.00670
1.984	10.400	.32800	.15620	-.01210	.01270	-.00290	-.00120	.00850	.01340	.02740	.00670
	GRADIENT	.04238	-.00265	-.00936	.00216	-.00003	-.00010	-.00008	-.00010	-.00086	-.00025

AMES 97-616 IAZ 01 TO S1 NO PLUMES

(RBJ523) (23 JAN 73)

REFERENCE DATA

SREF = 3155.0000 SQ.FT. XMRP = 86.4167 FT.
 LREF = 50.0000 FT. YMRP = .0000 FT.
 BREF = 73.5000 FT. ZMRP = 4.0000 FT.
 SCALE = .0190

PARAMETRIC DATA

ALPHA = .000 ELEVON = .000
 AILRON = 10.000 RUDDER = .000
 PLUMES = .000

RUN NO. 530/ 0 RN/L = 2.58 GRADIENT INTERVAL = -5.00/ 5.00

MACH	BETA	CN	CAF	CLM	CWBM	CY	CYN	CEL	CABCRB	CABTNK	CABSRM
1.600	-4.170	-.10300	.18130	.06460	-.01410	.16810	-.05380	.05540	.01780	.04050	.01050
1.600	-2.160	-.10400	.18120	.06550	-.01170	.09010	-.02990	.03580	.01670	.04080	.01050
1.600	-1.150	-.10500	.18130	.06620	-.01070	.04990	-.01790	.02570	.01660	.04080	.01040
1.600	-.140	-.10200	.18080	.06440	-.00980	.00530	-.00270	.01510	.01650	.04120	.01050
1.600	.860	-.10600	.18020	.06550	-.00890	-.03660	.01150	.00430	.01660	.04040	.01050
1.600	1.870	-.10700	.18070	.06520	-.00780	-.07800	.02470	-.00620	.01680	.04020	.01060
1.600	3.890	-.10600	.18010	.06490	-.00540	-.15740	.04980	-.02600	.01730	.04140	.01080
1.600	5.900	-.10700	.17870	.06400	-.00350	-.24770	.07950	-.04550	.01870	.04210	.01100
	GRADIENT	-.00045	-.00016	-.00000	.00105	-.04076	.01307	-.01019	-.00004	.00005	.00004

RUN NO. 560/ 0 RN/L = 2.11 GRADIENT INTERVAL = -5.00/ 5.00

MACH	BETA	CN	CAF	CLM	CWBM	CY	CYN	CEL	CABCRB	CABTNK	CABSRM
1.984	-4.120	-.09000	.17500	.05400	-.00950	.17300	-.06420	.04880	.01350	.03300	.00830
1.984	-2.120	-.08800	.17450	.05330	-.00740	.08940	-.03420	.03080	.01300	.03250	.00820
1.984	-1.110	-.08800	.17520	.05390	-.00700	.04800	-.01880	.02100	.01260	.03190	.00810
1.984	-.110	-.08800	.17530	.05420	-.00610	.00500	-.00250	.01120	.01230	.03150	.00800
1.984	.900	-.09100	.17490	.05480	-.00500	-.03690	.01320	.00120	.01250	.03200	.00810
1.984	1.910	-.09200	.17560	.05560	-.00430	-.08070	.02920	-.00860	.01240	.03180	.00800
1.984	3.910	-.09400	.17560	.05710	-.00260	-.16000	.05810	-.02660	.01300	.03260	.00820
1.984	5.930	-.09600	.17660	.05910	-.00100	-.24210	.08640	-.04260	.01320	.03260	.00820
	GRADIENT	-.00064	.00010	.00042	.00085	-.04165	.01536	-.00949	-.00008	-.00007	-.00002

AMES 97-616 IA2 01 TO S1 OMS NO PLUMES

(RBJ527) (23 JAN 73)

REFERENCE DATA

SREF = 3155.0000 SQ.FT. XMRP = 86.4167 FT.
 LREF = 50.8000 FT. YMRP = .0000 FT.
 BREF = 73.5000 FT. ZMRP = 4.0000 FT.
 SCALE = .0190

PARAMETRIC DATA

BETA = .000 ELEVON = .000
 AILRON = .000 RUDDER = .000
 PLUMES = .000

RUN NO. 504/ 0 RN/L = 2.60 GRADIENT INTERVAL = -5.00/ 5.00

MACH	ALPHA	CN	CAF	CLM	CMBM	CY	CYN	CBL	CABORB	CABTNK	CABSRM
1.600	-3.950	-.32400	.20260	.17650	-.01570	.00230	-.00110	.00210	.01860	.04360	.01130
1.600	-2.960	-.27700	.19790	.16460	-.01320	.00380	-.00130	.00070	.01890	.04390	.01140
1.600	-1.940	-.23400	.19520	.15530	-.01080	.00270	-.00100	.00120	.01900	.04340	.01120
1.600	-.930	-.18800	.19200	.14520	-.00770	.00370	-.00190	.00080	.01900	.04290	.01100
1.600	.050	-.14400	.18930	.13560	-.00530	.00160	-.00120	.00120	.01930	.04270	.01090
1.600	1.050	-.09600	.18580	.12460	-.00270	.00260	-.00130	.00030	.01970	.04220	.01080
1.600	2.070	-.05700	.18410	.11400	-.00020	.00130	-.00070	.00130	.01990	.04140	.01060
1.600	3.050	-.01300	.18130	.10070	.00260	.00340	-.00140	.00040	.02010	.04040	.01040
1.600	4.060	.03300	.17880	.08730	.00530	.00180	-.00080	-.00010	.02020	.04010	.01040
1.600	6.040	.12000	.17420	.05950	.01050	-.00230	.00120	-.00060	.02040	.04040	.01040
1.600	8.050	.21500	.17030	.03060	.01560	-.00230	.00050	-.00130	.02080	.04090	.01050
1.600	10.080	.31000	.16660	.00960	.01900	-.00680	.00110	-.00180	.01950	.04040	.01030
	GRADIENT	.04438	-.00289	-.01085	.00262	-.00012	.00003	-.00017	.00021	-.00049	-.00013

AMES 97-616 IA2 01 TO S1 OMS NO PLUMES

(RBJ528) (23 JAN 73)

REFERENCE DATA

SREF = 3155.0000 SQ.FT. XMRP = 86.4167 FT.
 LREF = 50.8000 FT. YMRP = .0000 FT.
 BREF = 73.5000 FT. ZMRP = 4.0000 FT.
 SCALE = .0190

PARAMETRIC DATA

ALPHA = -5.000 ELEVON = .000
 AILRON = .000 RUDDER = .000
 PLUMES = .000

RUN NO. 505/ 0 RN/L = 2.54 GRADIENT INTERVAL = -5.00/ 5.00

MACH	BETA	CN	CAF	CLM	CMBM	CY	CYN	CBL	CABORB	CABTNK	CABSRM
1.600	-4.170	-.38100	.20540	.19400	-.02340	.18240	-.06760	.04680	.01880	.04410	.01110
1.600	-3.160	-.38300	.20570	.19510	-.02240	.14150	-.05360	.03690	.01900	.04400	.01120
1.600	-2.160	-.38000	.20610	.19420	-.02120	.09350	-.03620	.02510	.01900	.04370	.01130
1.600	-1.150	-.37400	.20640	.19230	-.01980	.05030	-.01940	.01270	.01880	.04360	.01120
1.600	-.150	-.37700	.20560	.19240	-.01860	.00290	-.00210	.00140	.01870	.04440	.01140
1.600	.860	-.37600	.20590	.19400	-.01750	-.03960	.01470	-.01160	.01830	.04520	.01150
1.600	1.860	-.37800	.20510	.19340	-.01630	-.08270	.03100	-.02270	.01820	.04580	.01160
1.600	2.860	-.37800	.20500	.19450	-.01510	-.12900	.04790	-.03430	.01850	.04610	.01170
1.600	3.870	-.37900	.20450	.19410	-.01440	-.17960	.06440	-.04460	.01870	.04600	.01170
1.600	5.880	-.38100	.20340	.19120	-.01250	-.26700	.09510	-.06370	.01870	.04590	.01180
	GRADIENT	.00042	-.00014	-.00002	.00116	-.04483	.01661	-.01160	-.00007	.00033	.00008

AMES 97-616 IAZ 01 TO S1 OMS NO PLUMES

(RBJ529) (23 JAN 73)

REFERENCE DATA

SREF = 3155.0000 SQ.FT. XMRP = 86.4167 FT.
 LREF = 50.8000 FT. YMRP = .0000 FT.
 BREF = 73.5000 FT. ZMRP = 4.0000 FT.
 SCALE = .0190

PARAMETRIC DATA

ALPHA = .000 ELEVON = .000
 AIRCON = .000 RUDDER = .000
 PLUMES = .000

RUN NO. 506/ 0 RN/L = 2.54 GRADIENT INTERVAL = -5.00/ 5.00

MACH	BETA	CN	CAF	CLM	CWM	CY	CYN	CBL	CABORB	CABTNK	CABSRM
1.600	-4.160	-.15800	.18820	.13910	-.01110	.17080	-.05030	.04450	.01950	.04160	.01090
1.600	-3.170	-.15500	.19020	.14130	-.00970	.13360	-.04650	.03540	.01950	.04160	.01080
1.600	-2.160	-.15200	.19010	.14060	-.00850	.09750	-.03530	.02500	.01960	.04200	.01080
1.600	-1.150	-.15300	.18970	.13970	-.00720	.04680	-.01790	.01350	.01940	.04230	.01090
1.600	-.150	-.15100	.18950	.13890	-.00590	.00200	-.00190	.00120	.01920	.04240	.01080
1.600	.060	-.15700	.18950	.14040	-.00490	-.03850	.01490	-.01190	.01950	.04220	.01100
1.600	1.070	-.15400	.19040	.13950	-.00350	-.08110	.02950	-.02200	.01950	.04190	.01100
1.600	2.070	-.15400	.18990	.14000	-.00220	-.12470	.04390	-.03350	.01970	.04250	.01110
1.600	3.080	-.15500	.18980	.13970	-.00120	-.16530	.05730	-.04370	.01990	.04270	.01110
1.600	5.900	-.15500	.18920	.13610	.00070	-.24810	.08460	-.06440	.02010	.04300	.01120
	GRADIENT	.00012	.00010	-.00005	.00123	-.04245	.01485	-.01125	.00003	.00011	.00004

AMES 97-616 IAZ 01 TO S1 OMS NO PLUMES

(RBJ530) (23 JAN 73)

REFERENCE DATA

SREF = 3155.0000 SQ.FT. XMRP = 86.4167 FT.
 LREF = 50.8000 FT. YMRP = .0000 FT.
 BREF = 73.5000 FT. ZMRP = 4.0000 FT.
 SCALE = .0190

PARAMETRIC DATA

ALPHA = 5.000 ELEVON = .000
 AIRCON = .000 RUDDER = .000
 PLUMES = .000

RUN NO. 507/ 0 RN/L = 2.54 GRADIENT INTERVAL = -5.00/ 5.00

MACH	BETA	CN	CAF	CLM	CWM	CY	CYN	CBL	CABORB	CABTNK	CABSRM
1.600	-4.140	.07300	.17460	.07000	.00180	.16230	-.05370	.04250	.02060	.04110	.01080
1.600	-3.150	.07600	.17640	.07450	.00330	.12610	-.04300	.03290	.02040	.04090	.01060
1.600	-2.150	.07400	.17670	.07540	.00500	.08370	-.02800	.02180	.02030	.04040	.01040
1.600	-1.150	.07600	.17620	.07430	.00630	.04060	-.01380	.01050	.02040	.04030	.01040
1.600	-.150	.07600	.17640	.07430	.00780	.00010	.00070	-.00020	.02020	.04010	.01040
1.600	.850	.07600	.17590	.07360	.00970	-.04060	.01460	-.01170	.02050	.04090	.01050
1.600	1.860	.07600	.17620	.07370	.01100	-.08060	.02790	-.02350	.02030	.04130	.01040
1.600	2.850	.07600	.17590	.07470	.01200	-.12550	.04310	-.03380	.02040	.04180	.01050
1.600	3.860	.07800	.17600	.07240	.01340	-.16350	.05580	-.04440	.02050	.04180	.01050
1.600	5.860	.07800	.17580	.06930	.01530	-.24780	.08220	-.06360	.02080	.04310	.01080
	GRADIENT	.00027	.00005	.00010	.00146	-.04112	.01394	-.01100	-.00000	.00013	-.00002

AMES 97-616 IAZ 01 TO S1 M=1.4 SOLID SRM PLUME

(RBJ536) (23 JAN 73)

REFERENCE DATA

SREF = 3155.0000 SQ.FT. XMRP = 86.4167 FT.
 LREF = 50.8000 FT. YMRP = .0000 FT.
 DREF = 73.5000 FT. ZMRP = 4.0000 FT.
 SCALE = .0190

PARAMETRIC DATA

BETA = .000 ELEVON = .000
 AILRON = .000 RUDDER = .000
 FLUMES = .000

RUN NO. 586/ D RN/L = 2.54 GRADIENT INTERVAL = -5.00/ 5.00

MACH	ALPHA	CN	CAF	CLM	CWM	CY	CYN	CBL	CABORB	CABTNK	CABSRM
1.600	-3.920	-.19500	.16390	-.02250	-.00160	.00190	-.00180	.00080	.00000	-.00050	.00230
1.600	-1.930	-.13300	.15800	-.00510	-.00330	.00110	.00080	.00130	-.00030	.00030	.00110
1.600	-.950	-.09800	.15480	-.00310	-.00150	.00160	.00000	.00030	-.00010	.00010	.00150
1.600	.110	-.06100	.15220	-.00350	-.00010	.00220	-.00080	.00030	.00000	-.00010	.00170
1.600	1.070	-.02200	.15020	-.00530	.00150	.00380	-.00080	.00020	-.00020	-.00020	.00180
1.600	2.050	.01100	.14910	-.00400	.00310	.00100	-.00010	.00010	-.00020	-.00030	.00170
1.600	4.040	.08600	.14510	-.01510	.00780	-.00030	.00070	-.00060	-.00010	-.00060	.00130
1.600	6.080	.16400	.14420	-.02310	.01030	-.00300	.00180	-.00100	.00120	-.00040	.00180
1.600	8.050	.23300	.14050	-.02200	.01130	-.00530	.00180	-.00090	.00040	-.00080	.00150
1.600	10.090	.30900	.13620	-.01980	.01270	-.00720	.00120	-.00210	-.00200	-.00070	.00090
	GRADIENT	.03558	-.00234	.00071	.00128	-.00016	.00019	-.00019	-.00001	-.00005	-.00006

AMES 97-616 IAZ 01 TO S1 M=1.4 SOLID SRM PLUME

(RBJ536) (23 JAN 73)

REFERENCE DATA

SREF = 3155.0000 SQ.FT. XMRP = 86.4167 FT.
 LREF = 50.8000 FT. YMRP = .0000 FT.
 DREF = 73.5000 FT. ZMRP = 4.0000 FT.
 SCALE = .0190

PARAMETRIC DATA

ALPHA = .000 ELEVON = .000
 AILRON = .000 RUDDER = .000
 FLUMES = .000

RUN NO. 587/ D RN/L = 2.54 GRADIENT INTERVAL = -5.00/ 5.00

MACH	BETA	CN	CAF	CLM	CWM	CY	CYN	CBL	CABORB	CABTNK	CABSRM
1.600	-4.180	-.06800	.15610	.00170	-.00400	.16450	-.04980	.03800	.00070	-.00040	.00190
1.600	-2.160	-.06600	.15450	-.00090	-.00230	.08560	-.02680	.02020	.00060	-.00040	.00160
1.600	-1.150	-.06500	.15370	-.00280	-.00140	.04550	-.01430	.01080	.00040	-.00020	.00150
1.600	-.150	-.06400	.15260	-.00360	-.00020	.00340	-.00100	.00080	.00000	-.00050	.00160
1.600	.860	-.06600	.15250	-.00290	.00050	-.03700	.01180	-.00910	-.00050	-.00050	.00150
1.600	1.870	-.06500	.15310	-.00330	.00140	-.08010	.02530	-.01840	-.00020	-.00040	.00140
1.600	3.880	-.06700	.15330	-.00190	.00270	-.15580	.04710	-.03540	.00000	-.00050	.00180
1.600	5.900	-.07100	.15360	.00110	.00400	-.23970	.07260	-.05370	.00070	-.00030	.00230
	GRADIENT	.00012	-.00036	-.00046	.00085	-.04006	.01224	-.00923	-.00013	-.00002	-.00002

AMES 97-616 IA2 01 TO S1 M=1.4 SOLID SRM PLUME

(RBJ539) (23 JAN 73)

REFERENCE DATA

SREF = 3155.0000 SQ.FT. XMRP = 86.4167 FT.
 LREF = 50.8000 FT. YMRP = .0000 FT.
 BREF = 73.5000 FT. ZMRP = 4.0000 FT.
 SCALE = .0190

PARAMETRIC DATA

BETA = .000 ELEVON = 10.000
 AILRON = .000 RUDDER = 10.000
 PLUMES = .000

RUN NO. 588/ D RN/L = 2.54 GRADIENT INTERVAL = -5.00/ 5.00

MACH	ALPHA	CN	CAF	CLM	CMBM	CY	CYN	CBL	CABORB	CABTNK	CABSRM
1.600	-3.940	-.20800	.16730	-.01500	-.00400	.01370	-.01420	.00800	.00000	.00040	.00140
1.600	-1.900	-.14100	.15890	.00360	-.00400	.01120	-.01180	.00660	-.00060	.00020	.00080
1.600	-.970	-.10100	.15580	-.00130	-.00200	.01290	-.01220	.00680	-.00070	.00010	.00060
1.600	.020	-.06100	.15230	-.00680	-.00020	.01240	-.01210	.00600	-.00070	-.00030	.00070
1.600	1.080	-.02000	.14940	-.01280	.00230	.01230	-.01190	.00590	-.00070	-.00070	.00080
1.600	2.080	.02200	.14740	-.01980	.00450	.01100	-.01140	.00550	-.00070	-.00120	.00100
1.600	4.060	.10500	.14260	-.03860	.00960	.00900	-.00900	.00440	-.00060	-.00270	.00070
1.600	6.070	.19100	.14720	-.06060	.01420	.00670	-.00840	.00400	.00180	-.00270	.00110
1.600	8.080	.27200	.14290	-.06720	.01630	.00290	-.00790	.00360	.00150	-.00310	.00040
1.600	10.060	.35100	.13980	-.06890	.01770	.00160	-.00820	.00330	-.00030	-.00390	-.00060
	GRADIENT	.03949	-.00305	-.00364	.00180	-.00047	.00052	-.00042	-.00006	-.00036	-.00005

AMES 97-616 IA2 01 TO S1 M=1.4 SOLID SRM PLUME

(RBJ540) (23 JAN 73)

REFERENCE DATA

SREF = 3155.0000 SQ.FT. XMRP = 86.4167 FT.
 LREF = 50.8000 FT. YMRP = .0000 FT.
 BREF = 73.5000 FT. ZMRP = 4.0000 FT.
 SCALE = .0190

PARAMETRIC DATA

ALPHA = .000 ELEVON = 10.000
 AILRON = .000 RUDDER = 10.000
 PLUMES = .000

RUN NO. 589/ D RN/L = 2.53 GRADIENT INTERVAL = -5.00/ 5.00

MACH	BETA	CN	CAF	CLM	CMBM	CY	CYN	CBL	CABORB	CABTNK	CABSRM
1.600	-4.150	-.06200	.15600	-.00630	-.00280	.17740	-.06390	.04390	.00060	-.00250	.00150
1.600	-2.160	-.06400	.15470	-.00440	-.00160	.09800	-.04010	.02590	.00000	-.00200	.00110
1.600	-1.160	-.06300	.15350	-.00470	-.00090	.05710	-.02700	.01630	-.00020	-.00190	.00090
1.600	-.150	-.06200	.15350	-.00630	.00000	.01530	-.01290	.00660	-.00080	-.00210	.00050
1.600	.870	-.06200	.15300	-.00900	.00060	-.02770	.00070	-.00310	-.00110	-.00230	.00040
1.600	1.880	-.06400	.15450	-.00600	.00180	-.06920	.01340	-.01230	-.00060	-.00230	.00030
1.600	3.890	-.06100	.15420	-.00990	.00340	-.14890	.03730	-.03050	-.00040	-.00230	.00050
1.600	5.910	-.06000	.15490	-.01530	.00560	-.23150	.06310	-.04850	-.00020	.00200	.00110
	GRADIENT	.00012	-.00018	-.00045	.00077	-.04079	.01276	-.00931	-.00014	-.00001	-.00014

AMES 97-616 IA2 O1 TO S1 M=1.6 SOLID SRM PLUME

(RBJ541) (23 JAN 73)

REFERENCE DATA

SREF = 3155.0000 SQ.FT. XMRP = 86.4167 FT.
 LREF = 30.8000 FT. YMRP = .0000 FT.
 DREF = 73.5000 FT. ZMRP = 4.0000 FT.
 SCALE = .0190

PARAMETRIC DATA

BETA = .000 ELEVON = .000
 AILRON = .000 RUDDER = .000
 PLUMES = .000

RUN NO. 591/ 0 RN/L = 2.53 GRADIENT INTERVAL = -5.00/ 5.00

MACH	ALPHA	CN	CAF	CLM	CMBM	CY	CYN	CBL	CABORB	CABTNK	CABSRM
1.600	-3.940	-.18400	.15210	-.05820	.00340	-.00050	.00030	.00020	-.00720	-.01280	-.00210
1.600	-1.910	-.12300	.14640	-.03430	.00060	.00150	.00180	-.00040	-.00810	-.01690	-.00310
1.600	-.950	-.09600	.14380	-.02120	.00060	.00100	.00190	-.00080	-.00820	-.01820	-.00340
1.600	.030	-.06100	.14120	-.01310	.00080	.00060	.00150	-.00020	-.00800	-.01850	-.00330
1.600	1.080	-.02500	.13860	-.01160	.00210	.00160	.00110	.00000	-.00790	-.01870	-.00340
1.600	2.060	.01200	.13610	-.01370	.00370	.00060	.00150	-.00010	-.00790	-.01870	-.00340
1.600	4.060	.09300	.13140	-.02910	.00810	-.00140	.00180	-.00070	-.00770	-.01950	-.00350
1.600	6.110	.15700	.12880	-.02390	.00920	-.00480	.00370	.00020	-.00760	-.02000	-.00310
1.600	8.110	.22500	.12500	-.01450	.01010	-.00550	.00380	-.00070	-.00840	-.02050	-.00390
1.600	10.080	.29500	.12160	-.00500	.01070	-.00910	.00330	-.00070	-.00910	-.02090	-.00430
	GRADIENT	.03453	-.00259	.00398	.00062	-.00011	.00011	-.00005	-.00003	-.00074	-.00015

AMES 97-616 IA2 O1 TO S1 M=1.6 SOLID SRM PLUME

(RBJ542) (23 JAN 73)

REFERENCE DATA

SREF = 3155.0000 SQ.FT. XMRP = 86.4167 FT.
 LREF = 30.8000 FT. YMRP = .0000 FT.
 DREF = 73.5000 FT. ZMRP = 4.0000 FT.
 SCALE = .0190

PARAMETRIC DATA

ALPHA = .000 ELEVON = .000
 AILRON = .000 RUDDER = .000
 PLUMES = .000

RUN NO. 592/ 0 RN/L = 2.51 GRADIENT INTERVAL = -5.00/ 5.00

MACH	BETA	CN	CAF	CLM	CMBM	CY	CYN	CBL	CABORB	CABTNK	CABSRM
1.600	-4.180	-.07100	.14280	-.01000	-.00130	.15840	-.03860	.03400	-.00630	-.01560	-.00370
1.600	-2.180	-.07100	.14220	-.01130	-.00040	.08200	-.01930	.01710	-.00700	-.01620	-.00370
1.600	-1.140	-.06600	.14150	-.01620	.00040	.04250	-.00970	.00880	-.00730	-.01710	-.00380
1.600	-.150	-.06500	.14140	-.01490	.00070	.00350	.00060	.00050	-.00800	-.01790	-.00340
1.600	.860	-.06600	.14140	-.01440	.00110	-.03430	.01060	-.00730	-.00790	-.01730	-.00350
1.600	1.870	-.06600	.14120	-.01390	.00160	-.07220	.02030	-.01570	-.00730	-.01690	-.00390
1.600	3.880	-.06900	.14130	-.01200	.00280	-.14620	.03840	-.03120	-.00710	-.01610	-.00360
1.600	5.910	-.06600	.14050	-.02680	.00310	-.21070	.05360	-.03950	-.00600	-.00990	-.00270
	GRADIENT	.00043	-.00019	-.00035	.00052	-.03787	.00962	-.00806	-.00010	-.00009	.00001