

*Lewis*

NASA CR - 134533

R74AEG219

# THE IMPACT RESISTANCE OF CURRENT DESIGN COMPOSITE FAN BLADES TESTED UNDER SHORT-HAUL OPERATING CONDITIONS

## INTERIM REPORT

NASA-CR-134533)	IMPACT RESISTANCE OF	N74-18672
CURRENT DESIGN COMPOSITE FAN BLADES		
TESTED UNDER SHORT-HAUL OPERATING		
CONDITIONS Interim Report, Jul. (General		Unclass
Electric Co.) <del>60</del> p HC \$6.00	CSCI 01C	G3/02 29038

**66** July 1972 - June 1973

GENERAL ELECTRIC COMPANY  
Advanced Engineering and Technology  
Programs Department

PRICES SUBJECT TO CHANGE

prepared for

NATIONAL AERONAUTICS AND SPACE ADMINISTRATION

Reproduced by  
NATIONAL TECHNICAL  
INFORMATION SERVICE  
US Department of Commerce  
Springfield, VA. 22151



NASA Lewis Research Center  
Contract NAS3-16777

1. Report No. NASA CR-134533	2. Government Accession No.	3. Recipient's Catalog No.	
4. Title and Subtitle "Impact Resistance of Current Design Composite Fan Blades Tested Under Short-Haul Operating Conditions"		5. Report Date July 1973	6. Performing Organization Code
		8. Performing Organization Report No. R74AEG219	
7. Author(s) CA Steinhagen and CT Saleme		10. Work Unit No.	
9. Performing Organization Name and Address General Electric Company Evendale, Ohio 45215		11. Contract or Grant No. NAS3-16777	
		13. Type of Report and Period Covered Interim Contractor Report July 1972 - June 1973	
12. Sponsoring Agency Name and Address National Aeronautics and Space Administration Washington, D.C. 20546		14. Sponsoring Agency Code	
		15. Supplementary Notes Project Manager, R. Johns Materials and Structures Division NASA Lewis Research Center Cleveland, Ohio	
16. Abstract Boron/epoxy and graphite/epoxy composite blades were impacted in a rotating whirligig facility with conditions closely simulating those which might be experienced by a STOL engine impacted with various foreign objects. The tip speed of the rotating blades was 800 feet per second. The blades were impacted with simulated birds, real birds, ice balls, and gravel.  Strain gages, accelerometers, high speed movies, TTUCS (Through Transmission Ultrasonic C-Scan) measurements and sonic velocity measurements provided data on the extent and mode of impact damage.  The results of composite blade impact tests were compared with a titanium blade tested under similar conditions.  Delamination of the composite airfoil occurred when impacted with a 6 ounce bite from a 12 ounce bird. Both composite blades broke off at the root when impacted with a 12 ounce bite from a 28 ounce bird. Neither composite material indicated a clear superiority over the other. Blades made from both composite materials showed more damage than the titanium blades.  These data are the result of an eleven month testing effort extending from July 1972 to June 1973.			
17. Key Words (Suggested by Author(s)) Composites Impact Centrifugal Loading STOL Aircraft Foreign Object Damage (FOD)		18. Distribution Statement  Unclassified - Unlimited	
19. Security Classif. (of this report) UNCLASSIFIED	20. Security Classif. (of this page) UNCLASSIFIED	21. No. of Pages 60	22. Price* \$6.00

## FOREWORD

This interim technical report was prepared by the Aircraft Engine Group of the General Electric Company under NASA Contract NAS3-16777 and covers work performed during the period of July 1972 through June 1973 on a program to study impact resistance of composite fan blades.

This report covers the work completed under Tasks I, II and III. Single point foreign object damage (FOD) test data were obtained under simulated STOL engine take-off conditions on graphite/epoxy, boron/epoxy and titanium fan blades and the results evaluated.

The NASA Project Engineer was Mr. R. Johns of the Lewis Research Center. For the General Electric Company, Mr. C.A. Steinhagen was the Program Manager and Mr. C.T. Salemme was the Technical Manager. The portion of the program conducted at General Electric's Space Science Laboratory was under the direction of Mr. A.P. Coppa.

Other individuals who made significant Technical contributions to this program are:

Design -	Mr. M. Lawrence, Jr. and Mr. D. Dahlseid
Fabrication -	Mr. G. Murphy
NDI -	Mr. J. Zurbrick
Testing -	Mr. L. Kogan

**Preceding page blank**

## TABLE OF CONTENTS

<u>Section</u>		<u>Page</u>
1.0	SUMMARY	1
2.0	INTRODUCTION	3
3.0	TASK I - FABRICATION AND CERTIFICATION	4
3.1	Blade Description and Design	4
3.2	Blade Quality Assurance	4
3.2.1	Inspection Systems	4
3.2.2	Raw Material Control	4
3.2.3	Process Control	5
3.2.4	Inspection Tests	6
4.0	TASK II - IMPACT TESTING	7
4.1	Test Setup - Whirligig Impact Testing	7
4.1.1	Test Installation	7
4.1.2	Shrouding and Environment Chamber	7
4.1.3	High Speed Photography	8
4.1.4	Bird Injection System	8
4.1.5	Gravel and Ice Ball Injection	8
4.1.6	Foreign Objects	10
4.1.7	Instrumentation	13
4.1.8	Test Procedure	13
4.1.8.1	Blade Bench Check	13
4.1.8.2	Vehicle Balancing	13
4.1.8.3	Test Firing	15
4.2	Whirligig Impact Test Results	15
4.2.1	Bench Results	15
4.2.2	Impact Results	15
4.3	Inertial Head Impact Tests	33
4.3.1	Program Description	33
4.3.2	Description of Testing Facilities of Space Flight Center	39
4.3.3	Inertial Head Centrifugal Load Simulation Device (CLSD)	39
4.3.4	Test Results	39
5.0	TASK III - FOREIGN OBJECT DAMAGE EVALUATION	54
5.1	Nondestructive Evaluation of Impact Damage	54
6.0	CONCLUSIONS AND RECOMMENDATIONS	56
7.0	APPENDIX	57

**Preceding page blank**

## LIST OF FIGURES

<u>Number</u>		<u>Page</u>
1	Whirligig Impact Bird Injection Mechanism	9
2	Typical Foreign Objects	11
3	Photo Showing Containment of Simulated (RTV) Bird	12
4	Composite Blade Instrumentation	14
5	Titanium Blade Instrumentation	18
6	NG1 After Impact	22
7	NB2 After Impact	23
8	NG3 After Impact	24
9	NB4 After Impact	25
10	NG4 After Impact	26
11	NB3 After Impact	27
12	Titanium Blade After Impact	28
13	Typical Data Playback for Composite Blade	29
14	Blade Deflections from High Speed Movies	34
15	Typical RTV Recovered Projectile After Inertial Head Impacting of Composite Blades	36
16	Instrumentation Coordinate System Used for Inertial Head Impact Testing	40
17	Inertial Head Centrifugal Load Simulation Apparatus	41
18	Inertial Head Centrifugal Load Simulation Apparatus (Top)	42
19	NG5 Graphite/Epoxy Blade After Impact (Convex Surface) Test No. STOL 1	44
20	NG5 Graphite/Epoxy Blade After Impact (Concave Surface) Test No. 1 STOL 1	45
21	NB5 Boron/Epoxy Blade After Impact (Convex Surface) Test No. STOL 2	46
22	NB5 Boron/Epoxy Blade After Impact (Concave Surface) Test No. STOL 2	47
23	Titanium Blade After Impact (Convex Surface) Test No. STOL 3	48
24	Titanium Blade After Impact (Concave Surface) Test No. STOL 3	49
25	First Cycles of First Flexural Blade Vibration After Beginning of Impact (Boron-Epoxy)	51

## LIST OF TABLES

<u>Number</u>	<u>Title</u>	<u>Page</u>
I	TF39 Composite Blade Frequency Results	16
II	Relative Bench Strain Distribution and Strain Per Mil of Tip Deflection - 1st Flex	17
III	General Electric Whirligig Test Results	19 & 20
IV	Blade Deflections	30
V	Strain Gage Stress Summary of Whirligig Impact Test Results	31
VI	Blade Specimens	37
VII	Projectile Characteristics	37
VIII	Projectile Energy and Momentum	38
IX	Inertial Head Data	50
X	Blade and System Properties	52
XI	Kinetic Energy and Momentum Transferred to Blade	52

## 1.0 SUMMARY

The results of the effort to determine the impact resistance of composite fan blades are presented in this report.

### 1.1 Whirligig Results

For a 12 oz bird (simulated) with a 6 oz bite, both the graphite/epoxy and boron/epoxy blades were damaged yet remained intact. The graphite/epoxy experienced a crack in the dovetail and slight separation of the FOD protection from the leading edge on both sides of the airfoil. The boron/epoxy showed cracks at the tip at the leading and trailing edges with some delamination of the leading edge protection at the base of the airfoil.

A 12 oz bite off a 28 oz simulated bird caused blade failure, apparently resulting from high bending stresses, in both Gr/E and B/E blades at the airfoil root. The blades were contained easily and broke into relatively small pieces.

For the 11 oz bite off of the 16 oz real pigeon, both blades were damaged as revealed by NDE results. The extent of damage resulting from this impact suggests the upper limit on the bird size which can impinge upon the composite blades under the test conditions described without failure at the root.

There was no visible damage to the titanium blade when impacted with an 8 oz bite from a 16 oz pigeon. There was considerable deflection.

Results of this testing effort indicate no clear superiority of either the graphite/epoxy or the boron/epoxy composite blade material in resisting foreign object impact. Both blades showed some damage when impacted with a bite size of 11 oz from a real 16 oz pigeon. The titanium blade tested under this condition showed no visible damage but did show considerable deflection.

### 1.2 Inertial Head Facility Summary

Three blades, one graphite/epoxy, one boron/epoxy, and one titanium, were tested at the Space Science Center in the Inertial Head Facility.

Tensile loading, simulating centrifugal force, was applied to the composite blades but not to the titanium blade due to the higher loading required and the possibility of facility damage due to larger deflections expected.

Damage to both the graphite/epoxy and boron/epoxy blades were similar. There was a small amount of damage done to the titanium blade.

Initial inspection of the data obtained from the inertial head facility indicated results parallel to those obtained in the whirligig facility.



## 2.0 INTRODUCTION

The Advanced Engineering and Technology Programs Department of the General Electric Company, in accordance with NASA contract NAS3-16777, instituted an intensive testing program whose purpose was to determine if current fiber composite fan blades are sufficiently resistant to foreign object damage (FOD) to permit their adaptation to advanced STOL fan engines.

This report summarizes the work done during the period from July 1972 through June 1973 on the impact resistance of composite fan blades in accordance with NASA contract NAS3-16777.

Studies on the impact resistance of composite fan blades were divided into three tasks. In Task I, ten polymeric composite blades were manufactured following the basic TF39 Stage 1 fan blade geometry. Five blades each were made from boron/epoxy and graphite/epoxy materials.

Task II involved foreign object impact testing of eight of the blades manufactured in Task I and one titanium (Ti-6Al-4V) Stage 1 TF39 blade having identical airfoil geometry to provide a comparative reference point. These blades were impacted in the General Electric whirligig facility at conditions closely simulating engine operating conditions. The blades were impacted with RTV simulated birds, real birds, ice balls and gravel.

One additional blade of each design was impact tested statically in an inertial head facility at the General Electric Space Center to correlate impact conditions with strain energy absorbed during impact.

Evaluation of the impact damage resulting from impinging foreign objects on the blades was accomplished in Task III.

## 3.0 TASK I - FABRICATION AND CERTIFICATION

### 3.1 Blade Description and Design

Ten full-scale polymeric composite fan blades typical of those being proposed for use in large turbofan engines were fabricated. Two material combinations were manufactured for testing; 4.0 mil filament with a 5505 boron/epoxy resin system and Type A graphite fiber with a PR 288 epoxy resin system. These composite blades are of the design being developed by General Electric for the TF39 1st stage fan rotor. All blades had identical external airfoil geometry. Ply orientation for the graphite/epoxy blades were chosen to be  $0^{\circ}/+22^{\circ}/0^{\circ}/-22^{\circ}$  since this orientation provided an excellent balance between frequency and strength. The major criteria for specification of ply orientation for the boron/epoxy blades was blade frequency, i.e., having first and second bending and first torsional frequencies as close to the graphite/epoxy frequencies as possible. It is also necessary to cross excitation points such as the 2/rev stimulus within a certain fan speed range in order to avoid resonant frequency vibrations in the normal operating range.

The leading edge system consists of type 316 SS wire cloth (100 mesh) which is bonded to the leading edge of the blade. After autoclaving the surplus adhesive is carefully removed, the wire cloth lightly grit blasted and a precision plating of nickel is applied.

### 3.2 Blade Quality Assurance

#### 3.2.1 Inspection Systems

A timely and effective inspection system was established and maintained to ensure that defects or other unsatisfactory conditions were discovered and corrected at an early practical point. This system provides for determining material and product quality from the time raw materials are procured until test of completed articles. Quality Assurance is an integral part of blade fabrication.

#### 3.2.2 Raw Material Control

All materials used throughout this program were purchased to the contractor's specifications.

A quality control plan for inspecting incoming epoxy prepreg materials has been established at General Electric and used extensively over the past few years in the Polymeric Composite Blade Program. This plan established the requirements and methods for selecting satisfactory prepreg material for use in the General Electric molding activities. This plan includes the following operations.

- a) Checking inventory of incoming material and vendor's certifications for completeness and reported conformance to specification requirements.
- b) Logging in each lot and sheet received.
- c) Visual inspection of workmanship.
- d) Sampling of material and verification of compliance with specification requirements, including physical properties, reactivity and mechanical properties of a molded panel from each combination of fiber and resin batch.
- e) Handling and storage, and reinspection of out-of-date materials.
- f) Disposition of materials which fail to meet specification requirements.

Specific material properties which were measured and compared to vendor reported data on each prepreg lot are given below:

<u>Prepreg Data</u>	<u>Laminate Data</u>
Graphite, gms/ft <sup>2</sup>	Flexure str at RT, 250°F
Resin, gms/ft <sup>2</sup>	Flexure mod at RT, 250°F
Solvent content, % wt	Shear str at RT, 250°F
Gel time, mins at 230°F	Fiber content, % vol
Flow, % wt	Resin content, % vol
Visual discrepancies	Voids, % vol
	Density, gms/cc

Those individual test values, whether in the prepreg or laminate data, which failed to meet specification requirements were repeated using the same prepreg sheets. Failure to comply with specification requirements after retest was cause for rejection of those specific units of prepreg.

### 3.2.3 Process Control

Every operation involved in the manufacture of each polymeric composite blade was controlled by a separate planning and process control document. There was a separate file compiled for each blade into which is collated all the individual blade processing documents including all temperature, pressure, and closing speed recorder charts.

Precautions were adopted during the blade fabrication processes to avoid contamination of the prepregs, adhesives and bonding surfaces by contaminants such as dirt, moisture, etc.

- Clean Room - A clean room facility installed for critical blade processing is equipped with plastic topped tables for cleanliness. The area is air conditioned to maintain the prepreg and adhesives at a uniform temperature to provide constant "tack" (adhesive-like quality of the uncured material) conditions required to assist in layup of the blade laminate and adhesives.
- Material Control - All raw materials and preforms withdrawn from cold storage were allowed to warm up to ambient room temperature before extracting from the sealed bags to avoid moisture condensation on their critical surfaces. Care was also taken to expose the materials to room temperature for the shortest possible time to prevent uneven advancement of the resin systems prior to molding/bonding. The backing was maintained on the laminae up to the time they are installed in the preform die as a safeguard against possible contamination.

#### 3.2.4 Inspection Tests

All inspection records for each blade were filed by blade serial number in a separate file. This included all visual dimensional and NDT documents. A typical list of inspection documents in addition to inprocess checks carried out includes:

##### DOCUMENT

1. Blade Form - Ultrasonic inspection
  - a) Before nickel plate
  - b) After nickel plate
2. Holographic Photographs
  - a) Before nickel plate
  - b) After nickel plate
3. Root Dye Penetrant Inspection - Photographs
4. Root Area - Ultrasonic Inspection
5. Dimensional Inspection of Nickel Plate and Polyurethane
6. Final Inspection and Finishing

In addition to the above individual records of each blade, statistical data were tabulated for comparison and correlation of processing and NDT inspection. The final acceptance of the blade was based upon reviewing the visual inspection of the blades and their associated manufacturing and NDT data in conjunction with Engineering. Typical individual record samples of the acceptance of a blade by the Materials Review Board are provided in the Appendix.

## 4.0 TASK II - IMPACT TESTING

The purpose of this task was to perform foreign object impact tests on fiber composite and titanium blades designed for use in large turbofan engines.

Four graphite/epoxy blades, four boron/epoxy blades, and one titanium alloy blade were subjected to foreign object impact in a rotating whirligig facility. One graphite/epoxy, one boron/epoxy and one titanium alloy blade were impacted with foreign objects in an inertial head facility.

### 4.1 Test Setup - Whirligig Impact Testing

#### 4.1.1 Test Installation

The test installation is basically a standard TF39 fan package with additions and changes as required.

The structure consists of a TF39 fan frame with the number 1 and number 2 bearings and sump systems, the Stage 2 stator case, and slave Stage 1 shrouding. The entire installation was soft mounted and supported from rubber shock mounts and two spring-type hangers.

The rotor was made up from a TF39 fan stub shaft with a slave Stage 2 disc (ring) and Stage 1 spacer and Stage 1 disc for the composite blades. Only one blade was installed and tested at a time. The rotor was driven through a flex coupling and slave adapting shaft.

The disc for the test installation was provided with two opposing dovetail slots, one for the composite dovetail and one for the titanium dovetail. The slots were machined in the closed position relative to their standard setting angle to provide an impact incidence angle consistent with the TF39 blade takeoff conditions at a reduced fan operating speed of 800 ft/sec.

#### 4.1.2 Shrouding and Environment Chamber

The environment chamber provided the capability to operate in a helium atmosphere in order to reduce horsepower requirements and temperature buildup. The chamber also provided high speed photography capability and additional blade and bird containment.

#### 4.1.3 High Speed Photography

The environment chamber was made with three camera ports, located at the top, side and directly in front of the rotor, to permit high speed motion pictures to be taken from several angles simultaneously.

The camera equipment used to film the event was as follows:

- Front Camera: Hycam 400 ft, Model 41-0004.  
Speed setting -4500 frames/sec.  
Lens - 10 mm.
- Side Camera: Hycam 400 ft, Model 41-0004.  
Speed setting -4500 frames/sec.  
Lens -5.7 mm.
- Top Camera: Fastax, Model WF4.  
Speed setting -4500 frames/sec  
Lens -13 mm.

The lighting was provided by thirty-two 1000 watt (GE Par 64) spot lights mounted on the outside of the environment chamber and directed through individual glass ports. The blades and background were appropriately painted to reflect the light and provide contrast.

#### 4.1.4 Bird Injection System

In order to obtain a consistent and reproducible impact bite, the "fixed bird" technique was used. The bird was securely fixed to a mechanical injecting system which could insert (and retract) it a set depth into the path of the rotating blade. Basically the mechanism consisted of a cup (bird carrier) attached to the end of a spring loaded shaft which was supported and free to slide in two ball bushings. It was actuated by firing an explosive bolt which held the shaft (and spring) in the retarded (cocked) position. Figure 1 shows the injecting mechanism.

In order to obtain the required bite, the explosive bolt not only had to be fired when the rotor was at the required speed, but at an instant which would permit the blade to reach the impact point at the same time the bird reached the desired depth (full stroke). In addition, the camera and lights had to be activated to catch the event.

#### 4.1.5 Gravel and Ice Ball Injection

The gravel and ice balls were "injected" by allowing them to fall through a "j" shaped feeder tube and exit into the path of the

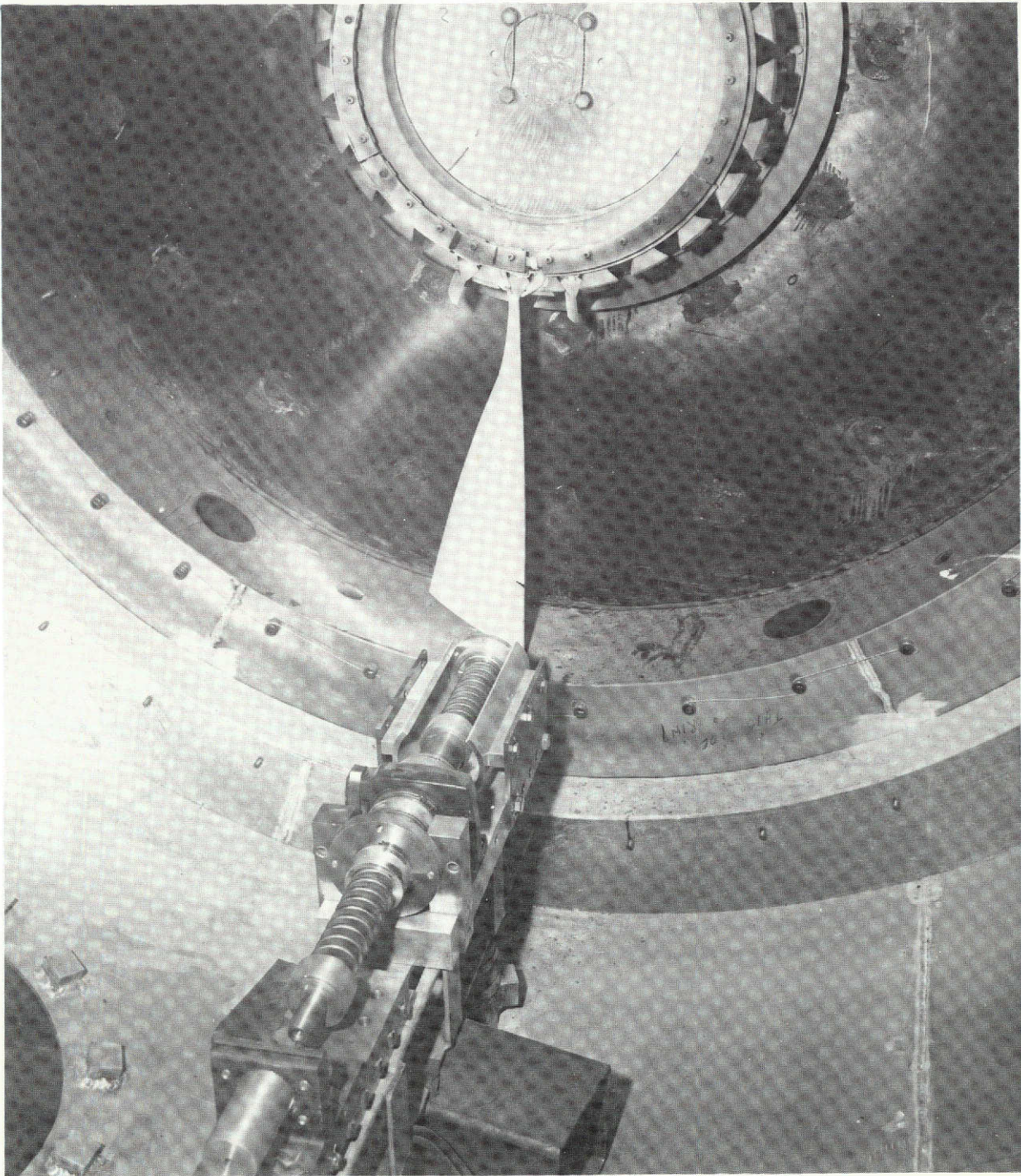

Figure 1. Whirligig Impact Bird Injection Mechanism.

This page is reproduced at the back of the report by a different reproduction method to provide better detail.

blade. The tube was secured to the environment chamber at approximately 12 o'clock but passed through it to permit the ice balls to be loaded from the outside just before the acceleration. The tube was equipped with a solenoid operated gate flap which was automatically actuated when the rotor reached triggering speed. It was determined that the timing was not particularly critical because the objects would not be falling fast enough to get through the blade path in less than a revolution.

#### 4.1.1 Foreign Objects

Each of the various typical foreign objects are shown in Figure 2.

- Simulated Birds - Silicone foam material (RTV) was used to makeup the simulated birds. They were made as either 3" or 4" diameter, hollow or solid cylinders such that the required weight bite could be obtained from a 2 1/2" slice. A typical simulated bird and cup after impact is shown in Figure 3.
- Real Birds: Common local variety pigeons weighing approximately 1 lb were used to obtain the real bird impact. These birds were epoxied into the injecting cup, feet first such that about 10 oz would be cut off in a 2 1/2" bite. The head, wings and feathers were maintained in a tucked in position by narrow fiberglass strips. This was done to help hold the bird and also prevent it from tearing apart due to turbulence from the passing blade. The birds were allowed to thaw to room temperature before firing.
- Gravel - Local "parking lot" type gravel was handpicked for 0.15 inch to 0.25 inch diameter size. Approximately 50 pieces were required to make 20 grams.
- Ice Balls - Three, 2-inch diameter ice balls weighing approximately 2.4 ozs each were used for each ice ball shot. They were made in rubber molds and frozen at 28° to -28°F. A small amount of washable black ink was added to color the ice balls so that they would show up in the film.



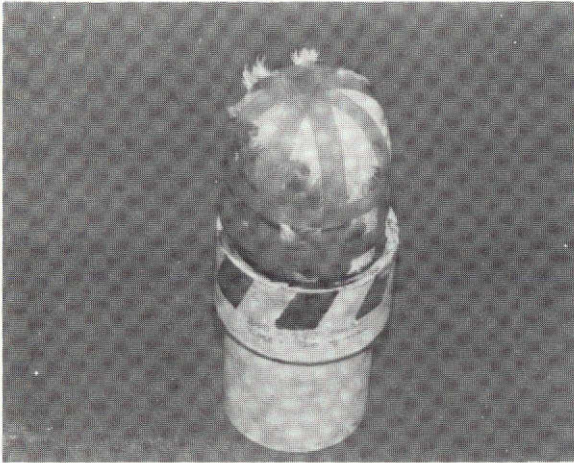

Typical Real Pigeon as Used in NASA-FOD Tests. Pigeon Weight 16 oz. Held in Carrier by Glass Straps and Cement.

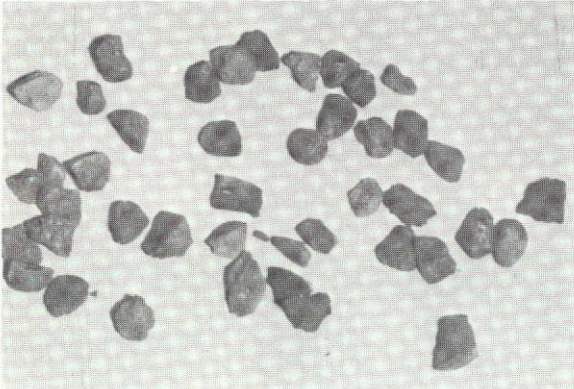

Stones and Gravel as Used in NASA-FOD Tests. Sized to 0.15" - 0.25" Dia. Total Weight: 20 Grams.

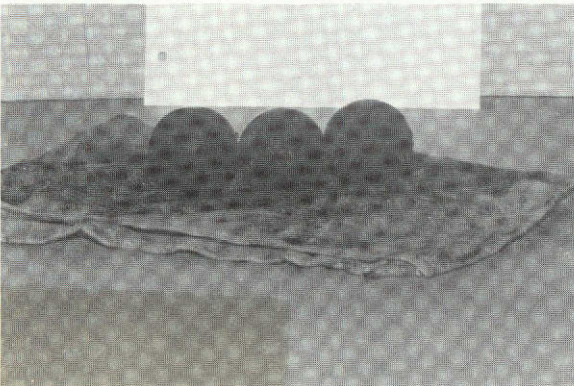

Tempered Hailstones as Used in NASA-FOD Tests. Made from Distilled H<sub>2</sub>O and Dyed Black. Total Weight of 3 Iceballs: 7.4 oz.

This page is reproduced at the back of the report by a different reproduction method to provide better detail.

Figure 2. Typical Foreign Objects.

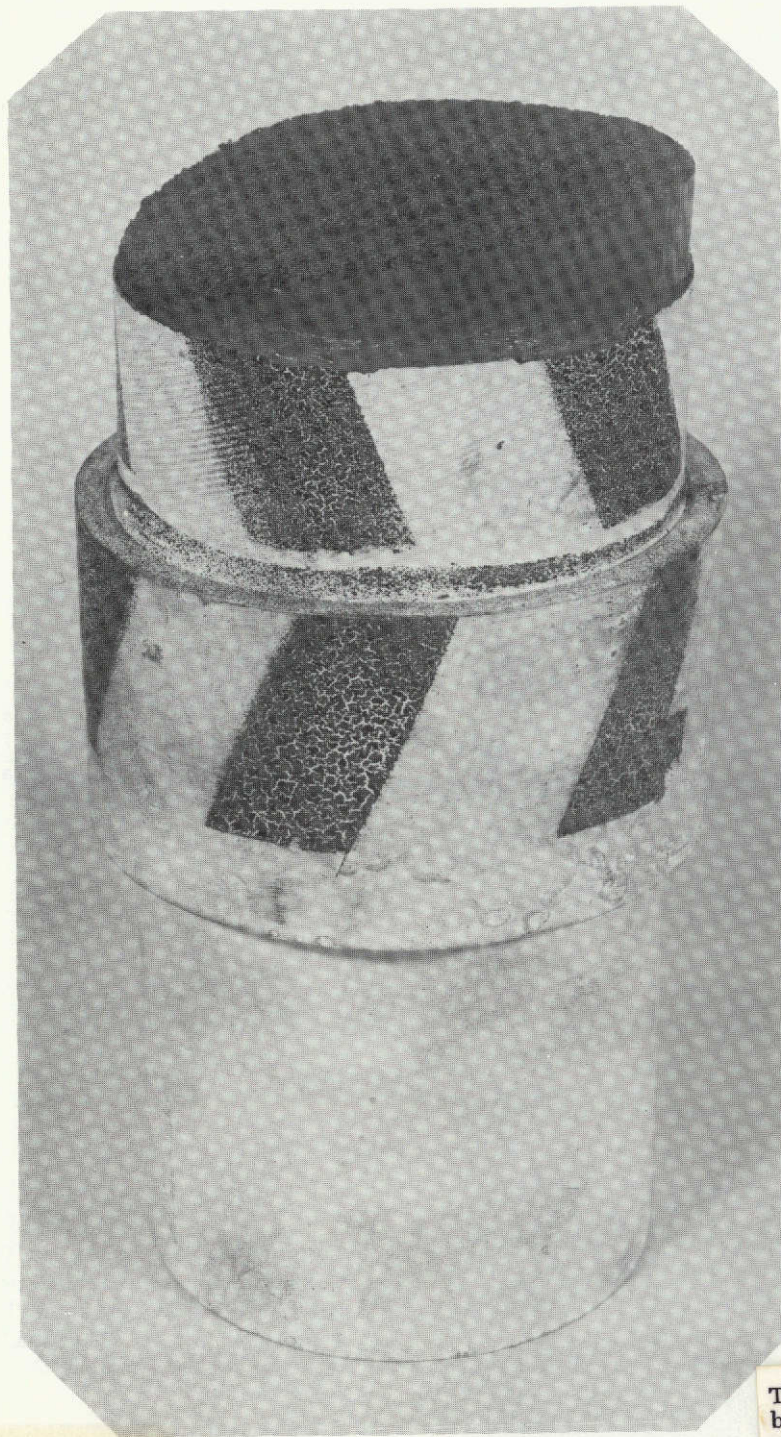

This page is reproduced at the back of the report by a different reproduction method to provide better detail.

Figure 3. Photograph Showing Containment of Simulated (RTV) Bird After Impact, 12 oz Slice Removed.

#### 4.1.7 Instrumentation

- Blade Instrumentation - All blades for bird impact testing were instrumented with seven dynamic gages (type EDDY-0.125 inch AD-350E) and one thermocouple. Gage locations, application system, and leadout path are shown in Figure 4.
- Test Installation Instrumentation - In order to monitor the condition of the test installation for operational safety purposes, suitable instrumentation was applied. This consisted of two thermocouples and two accelerometers for each bearing to observe bearing temperature and bearing housing vibration plus four standard CEC vibration pickups to monitor casing vibration.
- Data Acquisition - A 14 channel tape recorder was used to monitor and record all strain gages and accelerometers. To prevent strain gage burnout, due to the poorer heat dissipation of the composite blade material, the normal strain gage excitation voltage was reduced. The blade thermocouple along with some parallel strain gages and accelerometers were recorded using an 8 channel Sanborn Strip Chart recorder. Casing vibration and bearing temperatures were connected to standard meters for readout by the test operator.

#### 4.1.8 Test Procedure

##### 4.1.8.1 Blade Bench Check

Several of the early blades of each type plus the titanium blade were frequency checked and calibrated on the bench. This was done to establish the resonant frequencies of the first three modes and the tip deflection versus strain for each gage in the first flex mode.

The blade was clamped in a dovetail holding fixture which was mounted on a shake table. The driving frequency of the table was then scanned to obtain each resonant frequency. At the first flex frequency, the driving force was increased in increments to obtain increasing tip deflections up to 1/2 inch. Deflections were measured at the trailing edge.

##### 4.1.8.2 Vehicle Balance

Gross balancing to account for the weight variation of each of the types of blades was accomplished by installing a counterweight slave blade opposite the test blade. Titanium blades,

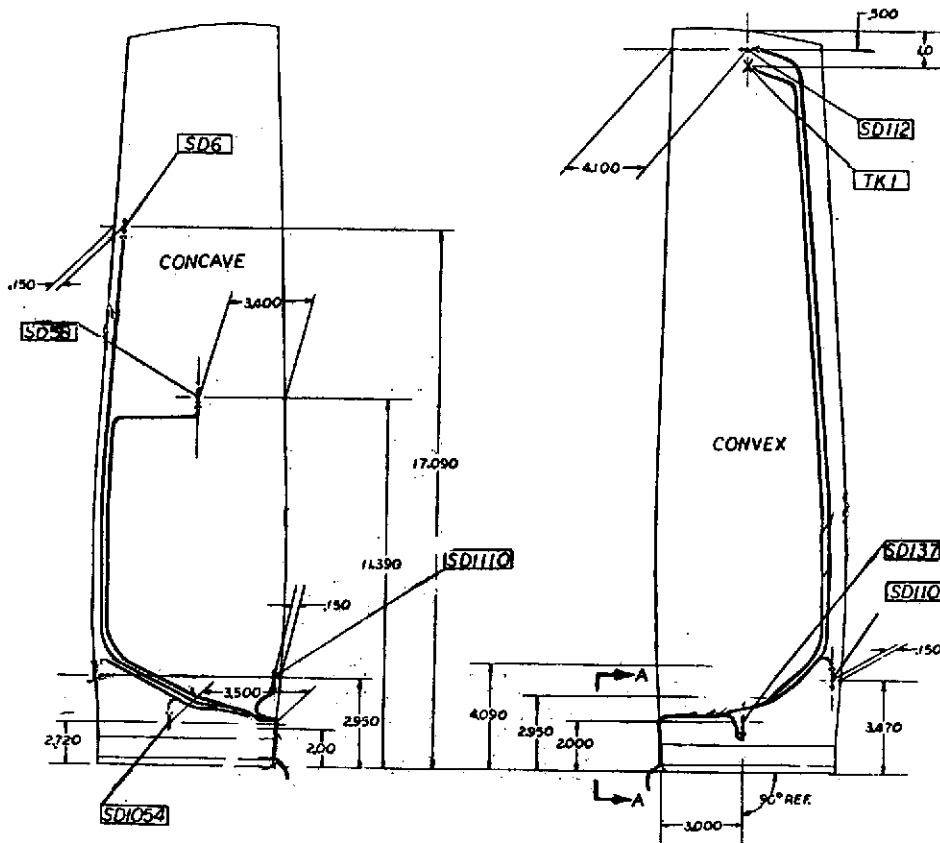

REVISIONS				
ZONE	LER	DESCRIPTION	DATE	APPROVED
A		ADDED TK 1	9/27/72	[Signature]
B		ADDED SD1110	10/17/72	[Signature]

- TK APPLICATION - SURFACE PRER PER NOTE 2 / RTC / 20112-L10 ENCAPSULATED TK.
  - CURE RTC FOR 1 HR AT 200°F CURE M/B 329 FOR 90 MIN AT 275°F DO NOT EXCEED TEMP.
  - LEADWIRE APPLICATION - SURFACE PRER PER NOTE 2 / LEADWIRE / M/B 329 / BEN-HAR TYPE 1151 (PROVIDE SNUG FIT ON LEADS) LOCATED IN DOVETAIL AREA / M/B 329 UNDER & OVER SLEEVING.
  - DYNAMIC S/G - EDDY-125 / AD-350E (2 WIRE HOOKUP)
  - S/G APPLICATION - SS WHITE VERY LIGHTLY TO AVOID DAMAGE TO FIBERS / ACETONE / MEUX / RTC / S/G / TT-50 T-STRIPS / USE CARE IN CLAMPING TO AVOID DAMAGE TO BLADE / 400°F SOLDER / 36 GA JUMPERS / 32 GA KAPTON TEFLON LEADWIRE / THIN COAT OF REWELD OVER GAGE TABS & T-STRIPS / M/B-329
1. MUST CONFORM TO:  
 ISOP D-15 M/B-329  
 ISOP E-9 RTC GAGE APPLICATION

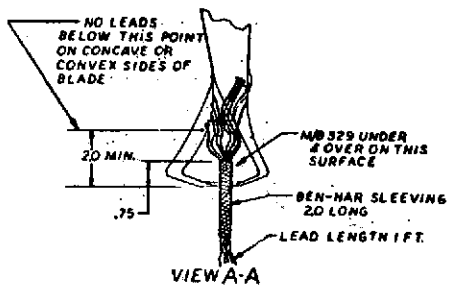

DUNS TYPE INSTRUMENTATION		TF-39	
UNLESS OTHERWISE SPECIFIED: DIMENSIONS ARE IN INCHES			
DESIGNED	SIGNATURES	MO-DA-YR	<b>GENERAL ELECTRIC</b> AIRCRAFT ENGINE GROUP CINCINNATI, OHIO, U.S.A.  <b>STG I FAN BLADE PHASE II B</b> <b>(COMPOSITE) CELL 63</b>  W/G
CHECKED	[Signature]	9-11-72	
ALL SURFACES	✓		
MATL.	[Signature]	9-11-72	
FOR Q & E USE ONLY	[Signature]	9-11-72	
SIMILAR TO			SIZE CODE IDENT NO. DUNE NO.
LAD			<b>C 07482 4098068-5582</b>
DR			SCALE: NONE   WT: 50%   SHEET: 2

Figure 4. Composite Blade Instrumentation.

cut off at the appropriate span, were used to balance the composite test blades while a specially-made dummy weight was used to balance the titanium test blade. Fine balancing was done by adding balance weights to the forward and aft flange of the Stage 1 disc.

#### 4.1.8.3 Test Firing

With the bird attached and the mechanism cocked, the drive was accelerated to approximately 2500 rpm. At this point, strictly to prevent pretest accidental or premature firings, the circuit breaker for the source of power for the lights and camera and the power switch to the firing box were turned on. The accel was then continued to actuate the automatic firing sequence at 2760 rpm. The rotor was decelerated immediately after impact to minimize possible secondary damage to the test rig. Still photographs were then taken of the results.

### 4.2 Whirligig Impact Test Results

#### 4.2.1 Bench Results

- Bench Frequency Check - The bench frequencies for the first three modes of all blades are shown in Table I. In addition, the after test frequencies for the first flex only are presented due to the extent of damage. These data show that for the most part, 1F frequencies remain the same. The biggest change in frequency occurred on graphite blade NG4 which was impacted with an 11 oz slice of a 16 oz pigeon.
- Bench Calibration - Table II shows the prior to test results of the calibration to obtain the strain versus tip deflection and the relative strain distribution for the first flex mode. For both graphite and boron composite blades gage SD 1110 (see Figure 4) shows the maximum response and is  $875 \mu$  in/in average at 1/2" tip deflection or  $1.75 \mu$  in/in per mil. Using  $\sigma = E\epsilon$  and the appropriate moduli this comes to 12100 psi (24.2 psi/mil) and 19700 psi (39.4 psi/mil) for the G/E and B/E blades, respectively. For the Ti blade the max shows on SD18 (see Figure 5) and is  $1000 \mu$  in/in (15800 psi) or  $2 \mu$  in/in (31.5 psi) per mil. Values for each gage are shown in the table.

#### 4.2.2 Impact Results

Table III summarizes the test results and gives the details and a brief description of the results for each

Table I. TF39 Composite Blade Frequency Results

S/N	Before 1F (cps)	After 1F (cps)	Before 2F (cps)	Before 1T (cps)
NG1	62	60	168	310
NG2	60	62	170	314
NG3	62	--	162	308
NG4	62	47	170	308
NG5	60	60	162	304
NB1	74	71	200	368
NB2	77	71	180	364
NB3	75	79	195	368
NB4	77	--	200	375
NB5	76	67	197	371

Table II. Relative Bench-Strain Distribution and Strain per Mil of Tip Deflection, 1st Flex Mode.

Blade S/N	SD 1110		SD 58		SD 1054		SD 137		SD 1108		SD 6		SD 112	
	%	Str/Mil	%	Str/Mil	%	Str/Mil	%	Str/Mil	%	Str/Mil	%	Str/Mil	%	Str/Mil
NG1	100	1.8	56	1.0	51	0.9	28	0.5	40.0	0.7	17	0.3	12	0.2
NG3	100	1.7	59	1.0	41	0.7	59	1.0	5.9	0.1	18	0.3	29	0.5
NB1	100	1.9	47	0.9	42	0.8	47	0.9	1.0	0.02	11	0.2	21	0.4
NB2	100	1.6	63	1.0	44	0.7	50	0.8	6.3	0.1	19	0.3	25	0.4
Ti Blade														
Ti THB02220	SD 18		SD 62		SD 79		SD 14		SD 77		SD 58		SD 1	
	100	2.0	60	1.2	55	1.1	50	1.0	50	1.0	35	0.7	10	0.2

NOTE: Although the results for S/G 1108 for Blades NG1 and NB1 show a larger variation than can be accepted without question, they are presented as they were obtained. No errors were found after the fact. It may be noted however, that this gage along with 6 and 112 are primarily torsion response gages rather than flex.

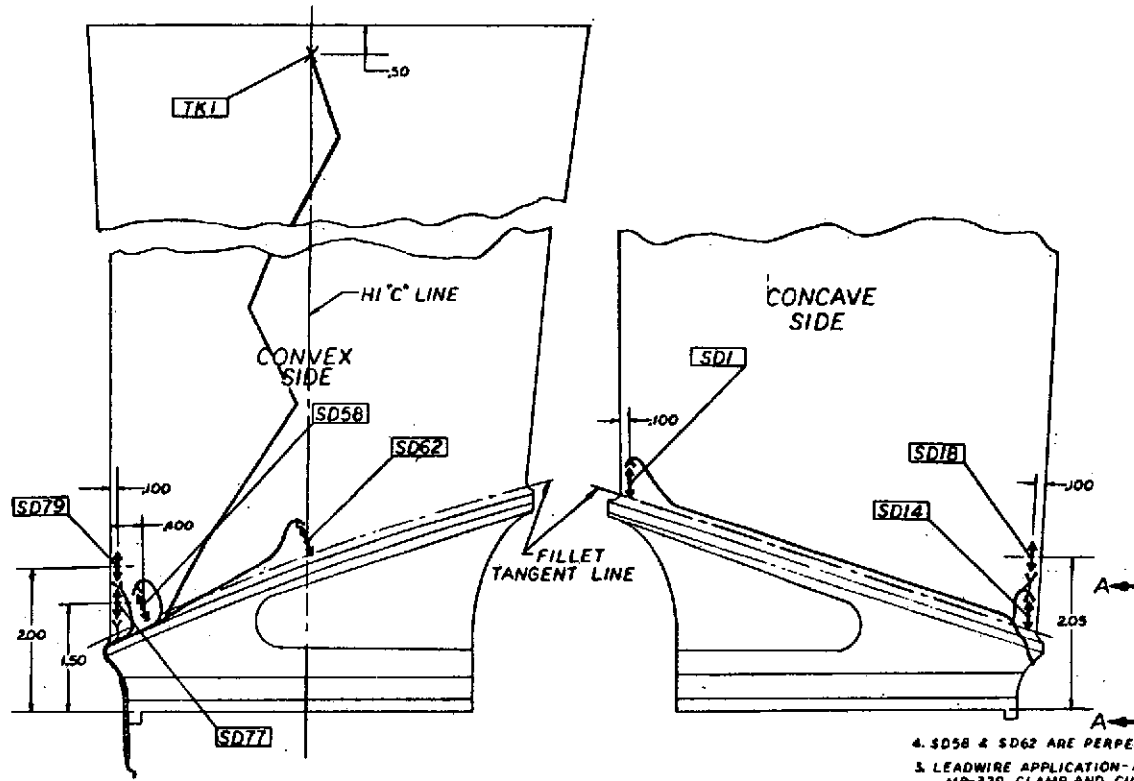

4. SD58 & SD62 ARE PERPENDICULAR TO THE FILLET TANGENT LINE.
5. LEADWIRE APPLICATION-ACETONE/120 GRIT BLAST/NEUT./LEADWIRE / MB-329 CLAMP AND CURE PER ISOP.
2. TK APPLICATION-SURFACE PRER PER NOTE 1/ BR-610/ 2012-L10 ENCAPSULATED T/C.
1. S6 APPLICATION-ACETONE/SILICON-CARBIDE WITH METAL COND./NEUT./ BR-610/EDDY-125AD-350-E/TT-50 T-STRIPS/450°F SOLDER/32 GA NAPTON-TEFLON LEADWIRE/THIN COAT OF REN WELD OVER GAGE TABS AND T-STRIPS.

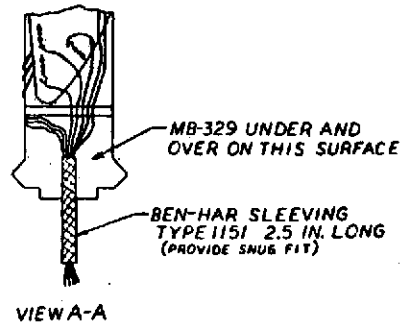

UNLESS OTHERWISE SPECIFIED: DIMENSIONS ARE IN INCHES		DWG TYPE INSTRUMENTATION		TF-39	
SIGNATURES		MO-DA-YR		GENERAL ELECTRIC	
DESIGN				AIRCRAFT ENGINE GROUP CINCINNATI, OHIO, U.S.A.	
CHECKED				TI STG I FAN BLADE	
DRAWN		1-17-73			
DATE		1-22-74			
REVIS		1-2-73			
FOR G E USE ONLY				SIZE CODE IDENT NO. DWG NO.	
SIMILAR TO				C 07482 4098068-5582	
L/D				SCALE NONE	
DR				SHEET 4	

Figure 5. Titanium Blade Instrumentation.



Table III. General Electric Whirligig Test Results

Blade Tip Speed - 800 ft/sec  
 Impact Incidence Angle - 22°  
 Impact Location - 4" From Tip

Blade S/N	Bird Size	Bite Size	Damage*
NG1	12 Oz Simulated Bird	6 Oz	Loss of sliver and delamination at trailing edge of blade tip. Crack in dovetail.
NB2	12 Oz Simulated Bird	6 Oz	Radial crack in tip. Very small crack in dovetail at leading edge.
NG3	28 Oz Simulated Bird	12 Oz	Blade broke off at root.
NB4	28 Oz Simulated Bird	12 Oz	Blade broke off at root.
NG4	16 Oz Real Pigeon	11 Oz	Crack in root, as indicated by dye penetrant. Delamination in tip area.
NB3	16 Oz Real Pigeon	10 Oz	Delamination at base of leading edge, piece out of tip at leading edge. Delamination across tip.
Ti	16 Oz Real Pigeon	8 Oz	No damage.

\*A more detailed description of impact damage is provided in the Non Destructive Evaluation Section.

Table III, (Continued) General Electric Whirligig Test Results

Blade Tip Speed - 800 ft/sec  
 Impact Incidence Angle - 22°  
 Impact Location - 4" From Tip

S/N	Condition	Damage *
NG2	Gravel 0.15" to 0.25" Diameter Total Weight - 20 gms	No visible damage.
NG2	Hailstones; Tempered Three, 2" Diameter	No visible damage.
NB1	Gravel 0.15" to 0.25" Diameter Total Weight - 20 gms	No visible damage
NB1	Hailstones; Tempered Three, 2" Diameter	Slight crack at trailing edge tip, large crack 6" long at leading edge metal plating.

\*A more detailed description of impact damage is provided in the  
 Non Destructive Evaluation Section.

test. Photographs of the blades after impact showing the extent of damage are presented in Figures 6 through 12. A typical taped data playback showing strains, frequencies, and time history of impact is presented in Figure 13. Blade deflections and events as observed from the high-speed movies are provided in Table IV.

- Stress Results - Table V shows the stresses for each gage as obtained from the taped data overall level and waveform playback.

The overall level ("O/L") values listed are the response amplitudes taken from the overall level playback. In this type playback the dynamic signal is converted to an equivalent DC voltage and the entire event (which occurs in a matter of milliseconds) shows as a very sharp spike. However, even with the short event time, the spike amplitude agrees reasonably well with the max peak-to-peak value shown by the waveform.

In the waveform type reduction, the tape is played back at a very slow speed which in effect stretches out the event time permitting the actual dynamic signal to be printed out. This then shows the time history of the event and allows for such things as frequencies, decay times, secondary impacts, etc. to be identified. The "W/F P-P" values listed in the table are the maximum peak-to-peak responses as obtained from waveform playbacks.

All recorded stresses were obtained by multiplying strain times modulus ( $\sigma = E\epsilon$ ) using the following values for the modulus (E):

Graphite/epoxy	-	13.8 x 10 <sup>6</sup>	psi
Boron/epoxy	-	22.5 x 10 <sup>6</sup>	psi
Titanium	-	15.8 x 10 <sup>6</sup>	psi

- Frequency and Time History - In general terms, the waveform playback seems to show the following:
  1. At the moment of impact and during the very short duration of blade/bird interaction, the response was forced and showed a mixture of frequencies.

This page is reproduced at the back of the report by a different reproduction method to provide better detail.

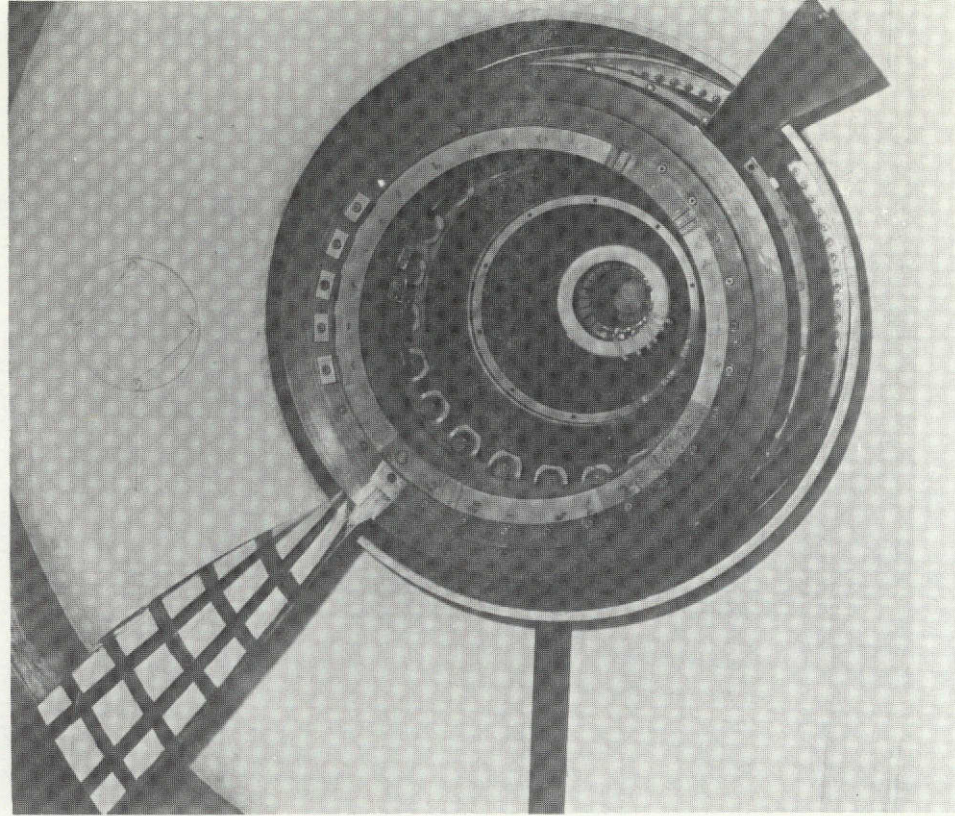
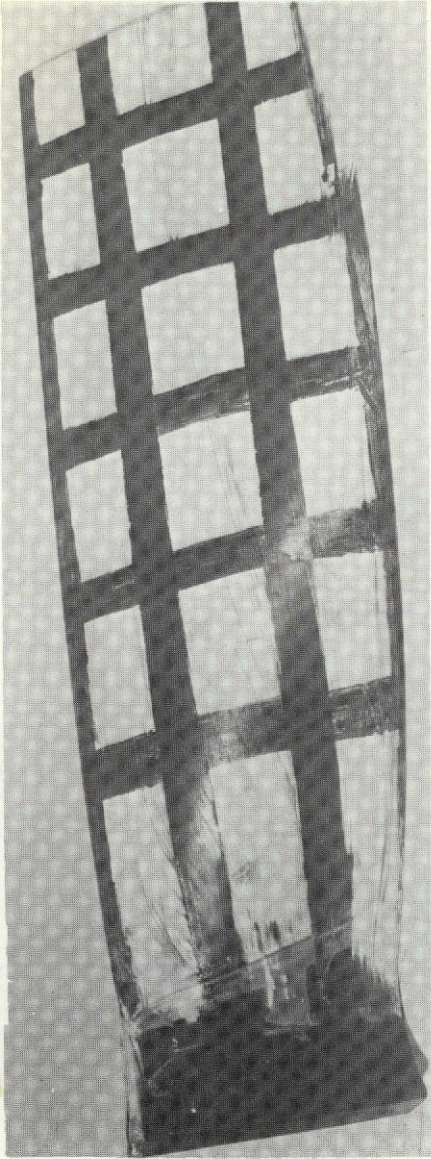

NASA-FOD Impact Resistance Test  
Blade S/N NG1  
Graphite/Epoxy  
Tip Speed: 800 ft/sec  
12 oz RTV Bird  
6 oz Slice  
22° Incidence Angle

Figure 6. Blade S/N-NG1 after Impact.

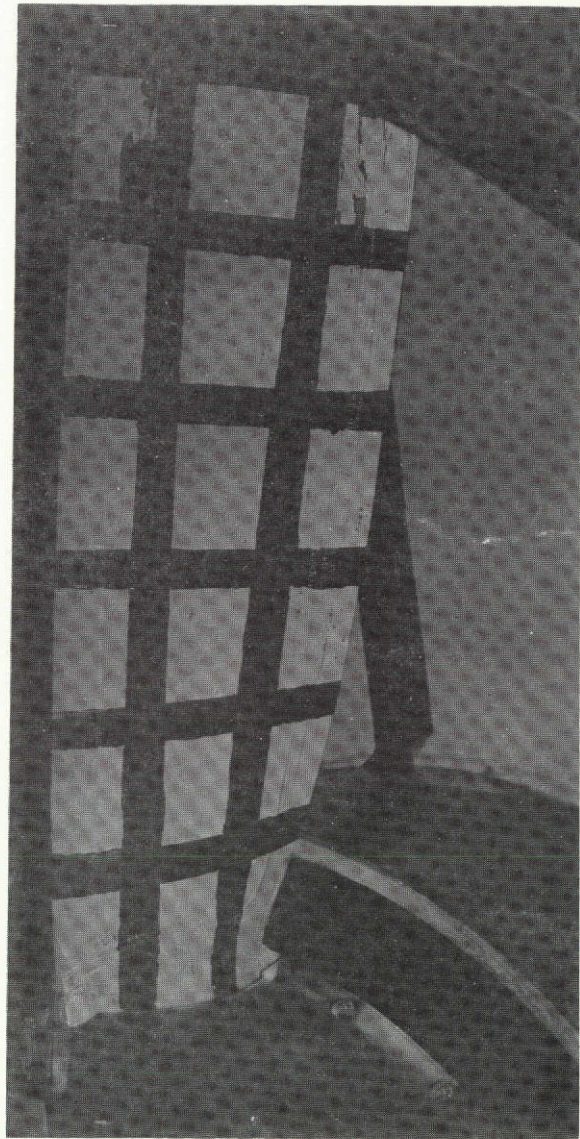
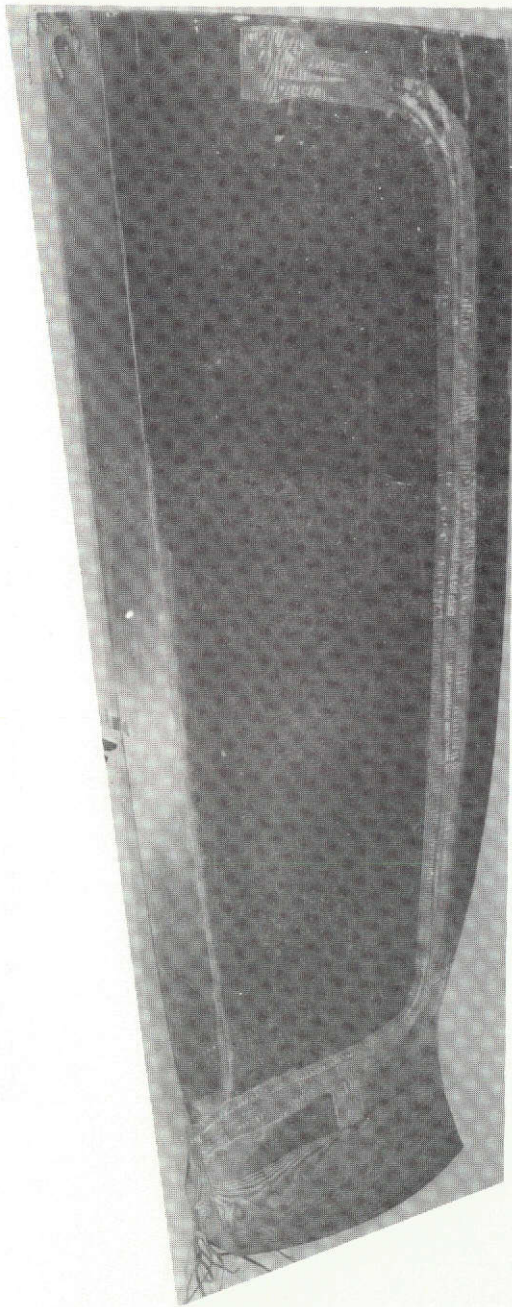

NASA-FOD Impact Resistance Test  
Blade S/N NB2  
Boron/Epoxy  
Tip Speed: 800 ft/sec  
12 oz RTV Bird  
6 oz Slice  
22° Incidence Angle

This page is reproduced at the back of the report by a different reproduction method to provide better detail.

Figure 7. Blade S/N-NB2 after Impact.

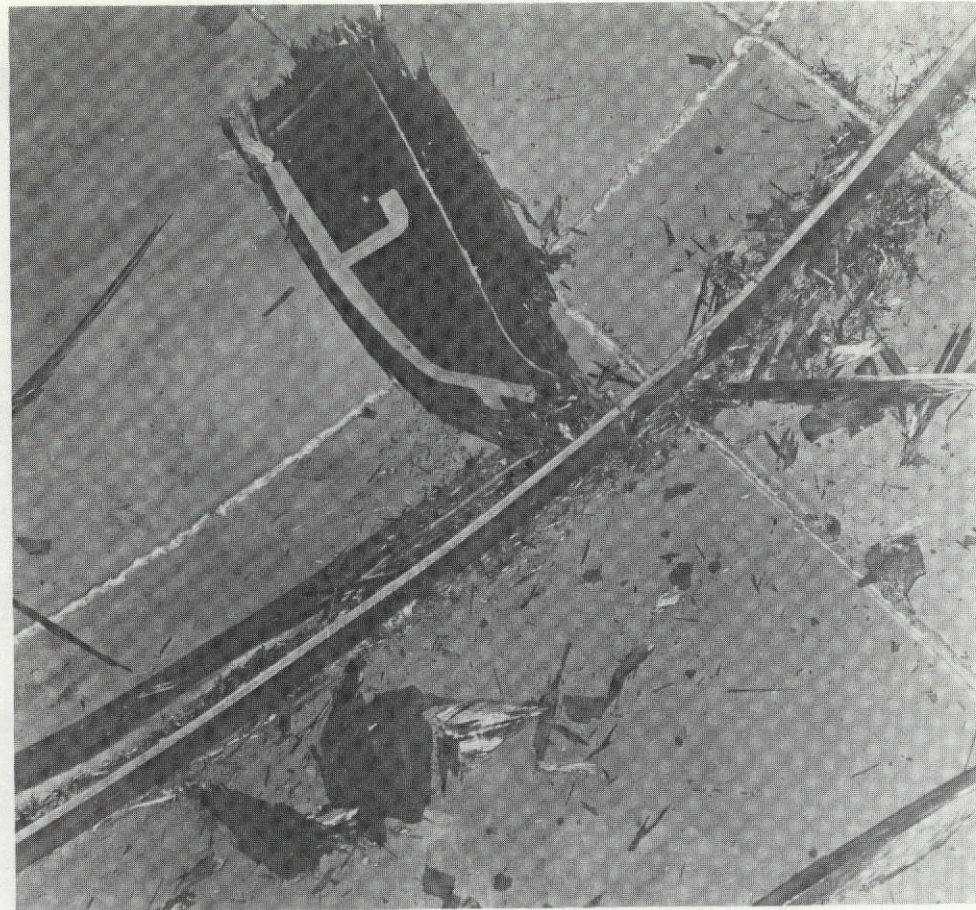
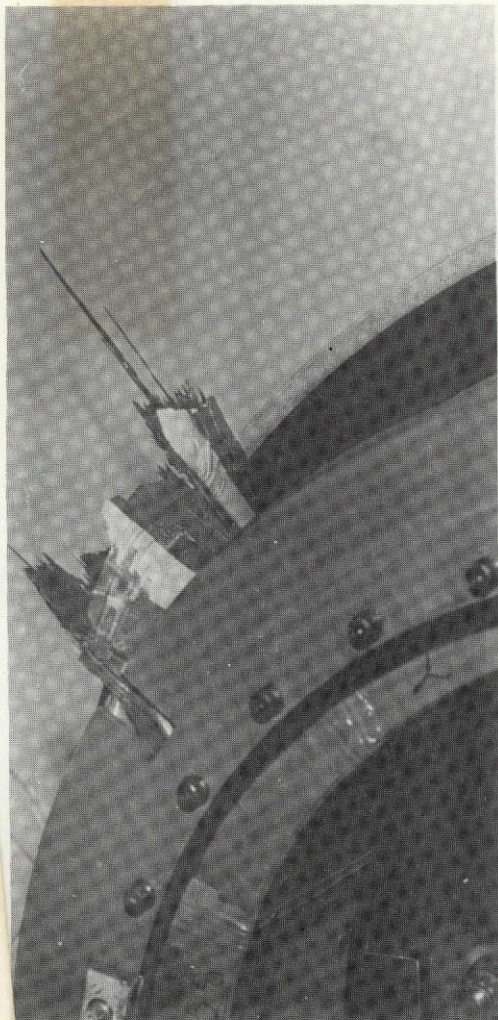

NASA-FOD Impact Resistance Test  
Blade S/N NG3  
Graphite/Epoxy  
Tip Speed: 800 ft/sec  
26 oz RTV Bird  
12 oz Slice  
22° Incidence Angle

Figure 8. Blade S/N-NG3 after Impact.

This page is reproduced at the back of the report by a different reproduction method to provide better detail.



This page is reproduced at the back of the report by a different reproduction method to provide better detail.

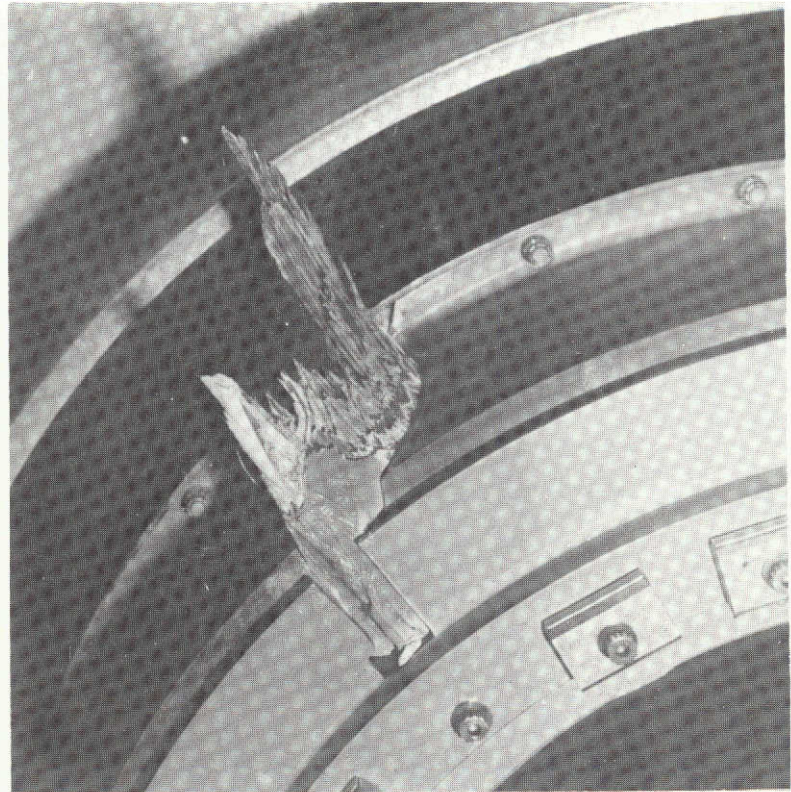

NASA-FOD Impact Resistance Test  
Blade S/N NB4  
Boron/Epoxy  
Tip Speed: 800 ft/sec  
26 oz RTV Bird  
12 oz Slice  
22° Incidence Angle

Figure 9. Blade S/N-NB4 after Impact.

NASA-FOD Impact Resistance Test  
Blade S/N NG4  
Graphite/Epoxy  
Tip Speed: 800 ft/sec  
16 oz Real Pigeon  
11 oz Slice  
22° Incidence Angle

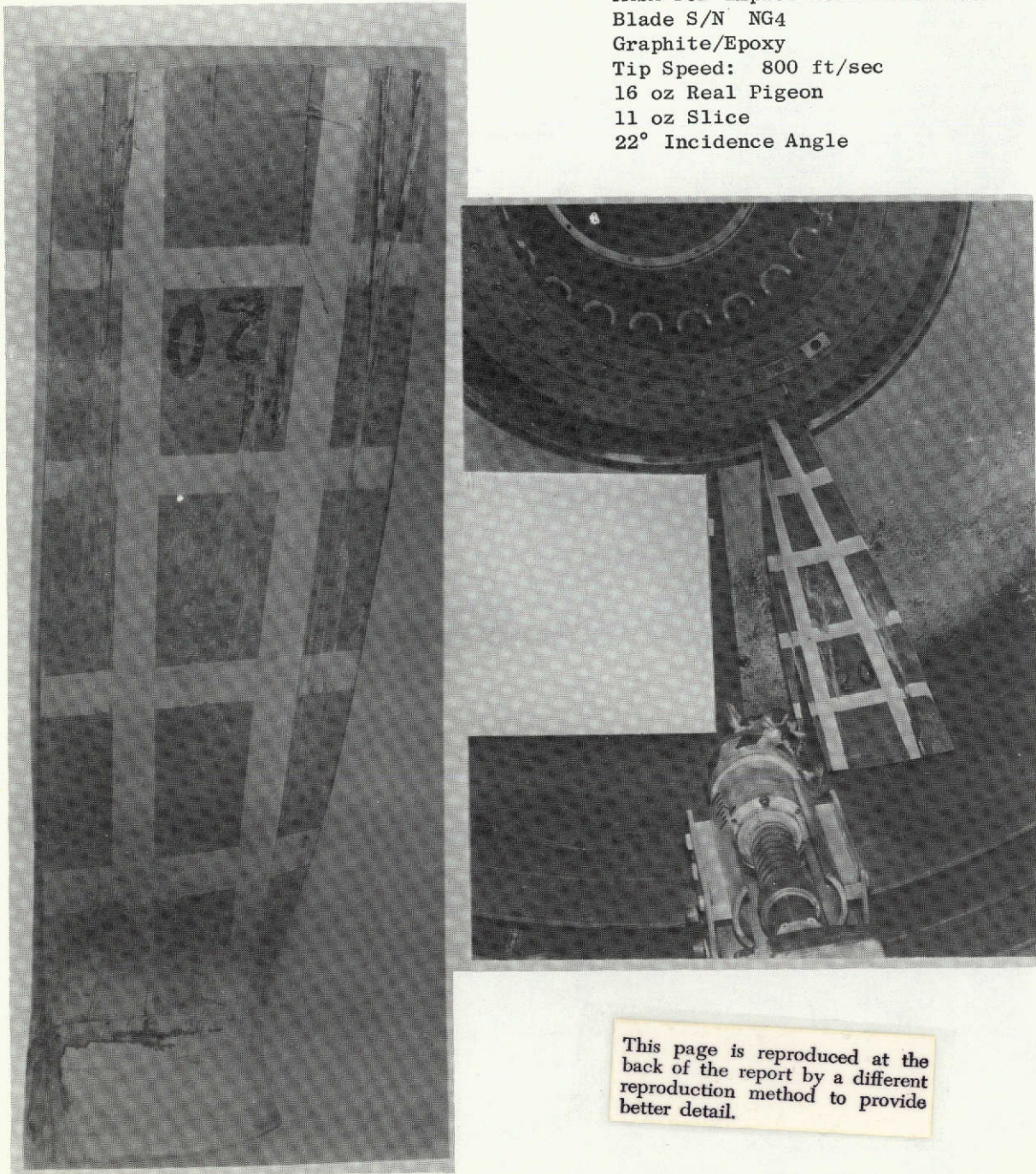
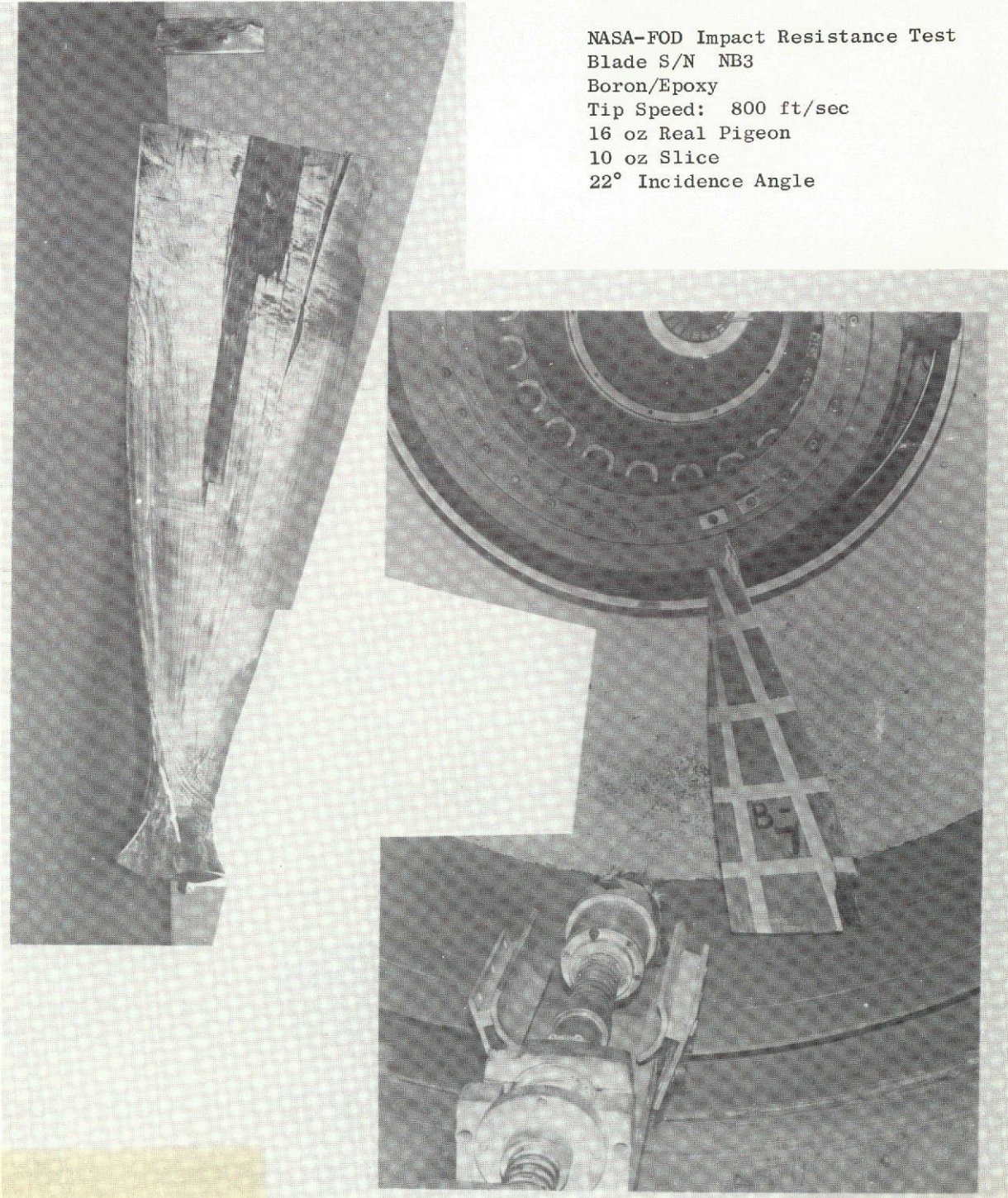

Figure 10. Blade S/N-NG4 after Impact.



NASA-FOD Impact Resistance Test  
Blade S/N NB3  
Boron/Epoxy  
Tip Speed: 800 ft/sec  
16 oz Real Pigeon  
10 oz Slice  
22° Incidence Angle



This page is reproduced at the back of the report by a different reproduction method to provide better detail.

Figure 11. Blade S/N-NB3 after Impact.

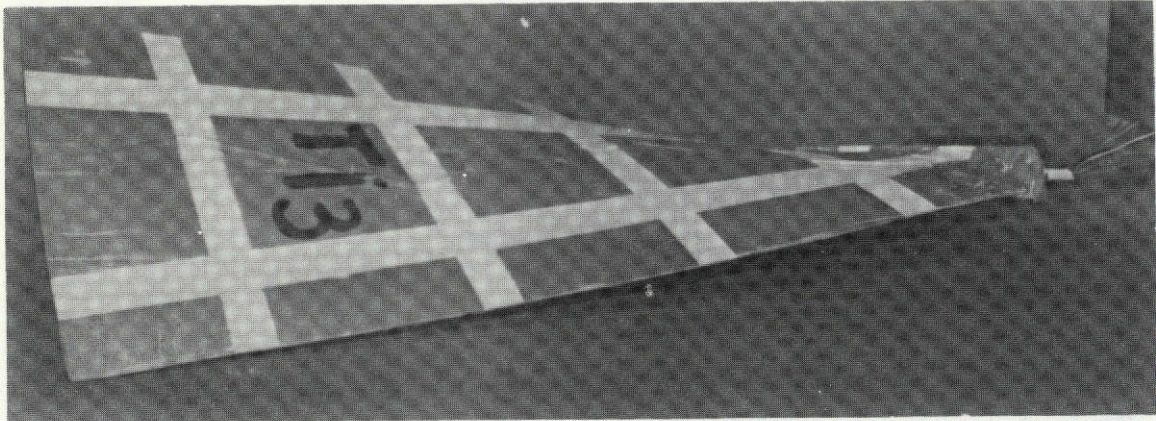

After Test

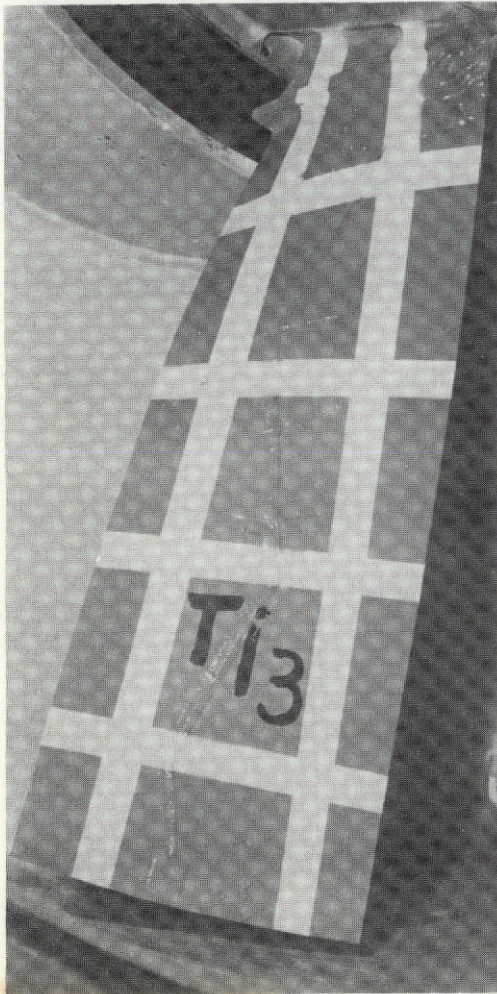

NASA-FOD Impact Resistance Test  
Blade S/N Ti3  
Titanium  
Tip Speed: 800 ft/sec  
16 oz Real Pigeon  
8 oz Slice  
22° Incidence Angle

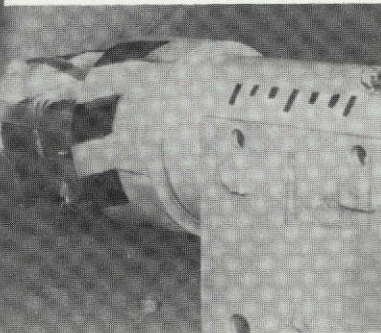

Before Test

This page is reproduced at the back of the report by a different reproduction method to provide better detail.

Figure 12. Titanium Blade after Impact.



Table IV. Blade Deflections.

Blade S/N	Bite Size	Blade Failure	Front View		Calculated Stress at 3 o'clock kpsi Single Amplitude Reference to Gage No. 1110	Side View	Top View		Notes
			Blade Deflection (Inches) 5 o'clock	3 o'clock		Deflection (Inches) 5 o'clock	5 o'clock L/E	T/E	
NG1	6 Oz RTV	No	0.31	1.25	30	1.1	1.7	1.7	Hit debris 3rd & 4th rev.
NB2	6 Oz RTV	No	0.47	1.25	49	1.4	2.1	2.1	Hit debris 3rd rev.
NG3	12 Oz RTV	Yes	1.88	5.0	121	3.2	No Film		Blade separated at 3 o'clock.
NB4	12 Oz RTV	Yes	0.94	4.4	173	No Film	No Film		Blade separated at 3 o'clock.
NG4	11 Oz Pigeon	No	1.56	4.2	100	3.5	4.0	Obscured	Hit debris 2nd, 3rd and 4th rev.
NB3	10 Oz Pigeon	No	---	---	---	2.2	2.6	Obscured	Hit debris 2nd - 6th rev.
Ti	8 Oz Pigeon	No	1.875	4.55		---	2.34	Obscured	Good impact. No visible damage.
Gravel and Ice Ball Impact									
Blade S/N	Bite Size	Blade Failure	Deflections At 12 o'clock		Calculated Stress @ 3 o'clock (kpsi - Single Amplitude)			Notes	
			None	0.78		--	19		
NG2	Gravel Ice Balls	No No	None	0.78	--	19		Hit gravel for 4 revs. Hit 2 ice balls on 1st rev, 1 on second rev.	
NB1	Gravel Ice Balls	No No	None	0.3	--	12		Hit gravel for 3 revs. Hit 1 ice ball on each of 3 revs.	

\*Objects injected at 6 o'clock position, blade rotating counterclockwise.

Table V. Strain Gage Stress Summary of Whirligig Impact Test Results.

Blade S/N	Bite Size	SD 6		SD 112		SD 1108		SD 58		SD 1110		SD 1054		SD 137		Blade Temperature (°F)	Results
		O/L DA	W/F P-P	O/L DA	W/F P-P	O/L DA	W/F P-P	O/L DA	W/F P-P	O/L DA	W/F P-P	O/L DA	W/F P-P	O/L DA	W/F P-P		
NG1	6 Oz RTV	OD	41	OD	17	53	60	44	33	53	58	47	57	66	60	175	Broken piece at tip D/T crack.
NB2	6 Oz RTV	103	110	OD	15	67	66	56	49	85	88	45	49	61	55	160	Tip crack Small crack D/T L/E
NG3	12 Oz RTV	OD	35	11*	10*	OD	66	OD	105	OD	61	OD	79	OD	96	180	Broke off at D/T.
NB4	12 Oz RTV	OD	80	OD	14	OD	87	OD	76	OD	68	OD	38	OD	46	180	Broke off at D/T.
NG4	11 Oz Pigeon	OD	71	OD	7	77	77	69	77	126	110	44	53	33	37		Tip cracks
NB3	10 Oz Pigeon	91	30	10	9	58	55	OD	53	61	76	56	50	76	290*		Broken tip piece and tip crack.
		SD 1		SD 14		SD 18		SD 58		SD 58		SD 62		SD 79			
T1 THB 02220	8 Oz Pigeon	110	140	137	60	175	180	80	90	OUT		110	130	125	150		No damage

NOTES:

1. Abbreviations: O/L = Overall level (playback)  
W/F = Waveform (playback)  
OD = Amplifier overdriven - no data  
DA = Double Amplitude  
P-P = Peak to peak
2. Values are kpsi
3. \*These values are questionable
  - For blade NG3 which broke off at the dovetail, thereby presumably severing the gage leads, the resulting signal should have overdriven the system. However, the tape chart shows what appears to be a good signal.
  - For blade NB3, this value is not typical of other values in the table and is inconsistent with its O/L. A scale or calibration error may be at fault.

2. In most cases this interaction period was very short and was over in less than  $30^\circ$  of rotation (1-2 milliseconds). The gages indicated that at this point (approximately 5 o'clock) the blade had fundamentally been bent over in a first flex attitude and torsionally had already untwisted and was on its way back.
  3. For the most part, after the initial interaction, the waveforms were clean showing first flex and first torsional decay. For both types of composite blades SD 58, 1110, 1054 and 137 showed primarily flex while SD 6, 112 and 1108 showed torsion. For the titanium blade only SD 1 showed torsion while the remaining gages showed flex (see Figures 4 & 5 for gage locations).
  4. For the blades which didn't break off or were intact enough to show this pattern, the flex response reached its peak around  $100^\circ$  after impact (between 2 and 3 o'clock).
  5. For the blades which did break off, amplifier saturation occurred less than  $90^\circ$  after impact resulting in no meaningful stress data from playback tapes.
  6. In cases where only a small piece of blade broke off, the gages indicated that the separation or crack didn't happen immediately, but after several revolutions and sometimes apparently as a result of secondary impact.
  7. Many of the torsional gages showed minor secondary impacts which correlated time wise to integral revolutions.
  8. Generally the response, without secondary impacts, decays to near zero anywhere from 3 to 10 revolutions after impact.
- Deflection Results - Table IV is a summary of the deflections and observations as seen from the high speed films. Since these deflections are a combination of bending and twisting and since each camera shows a different angle, the values from each view are necessarily different.

The measurements were made by marking the blade's position on the movie screen on the revolution prior to impact and then rechecking just after impact. Figure 14 shows the different views and identifies the measurements taken. In general, the films show that at impact the blades began to bend back in a flex attitude and reach a maximum between 5 and 3 o'clock. During this time the blade also shows twisting at the tip.

Table IV shows a calculated stress for the 3 o'clock position based on the tip deflection per mil for the max. gage obtained from the bench results. These calculated stresses assume that all of the deflection was first flex bending and are generally higher than the taped data playback. Nevertheless, except for the blades which broke off they agree reasonably well with playback data.

- Photographs - The after impact photos show the details and extent of damage for each blade. One of the consistent results is the crack which goes along the bottom of the dovetail and up both faces. This crack appears in each of the G/E blades (NG1, NG3, NG4) impacted with birds or simulated birds but only shows up for the one B/E (NB4) blade which broke off at the root. Otherwise for the blades which didn't break off, damage was fairly typical. Damage consisted of radial cracks and splinters at the blade tip with an occasional small crack at the dovetail root.

#### 4.3 Interior Head Impact Tests

##### 4.3.1 Program Description

Three impact tests on full scale TF39 composite fan blades were conducted by the GE Space Sciences Laboratory at the GE Morgantown Test Site. Blade specimens are described in Table VI.

Simulated bird-carcass projectiles were impacted against these blades while they were mounted on the inertial head apparatus to be described later. The projectiles were in the form of solid circular cylinder and made of RTV plastic foam according to a formulation originally developed in a previous program conducted at the GE Space Sciences Laboratory.

During impact, a portion of the projectile is sliced off and deflected by the blade and this portion travels along the concave surface of the blade, exerting force on it, due principally to

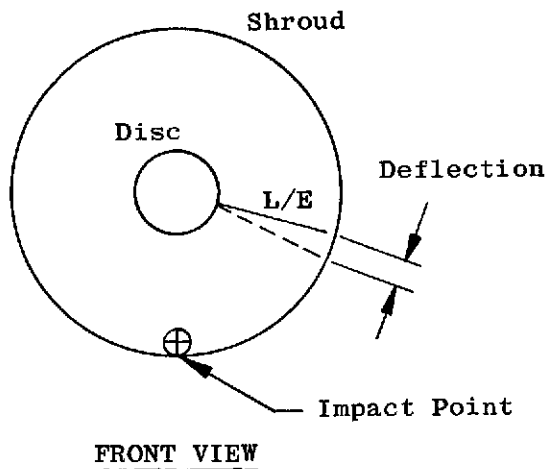

Front and side views show position of blade leading edge before and after impact typical for 5 and 3 o'clock positions.

—— Before Impact  
 - - - - After Impact

FRONT VIEW

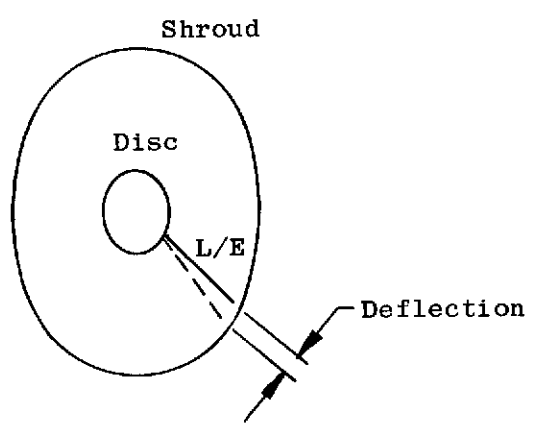

Deflections are a combination of bending and twisting.

SIDE VIEW

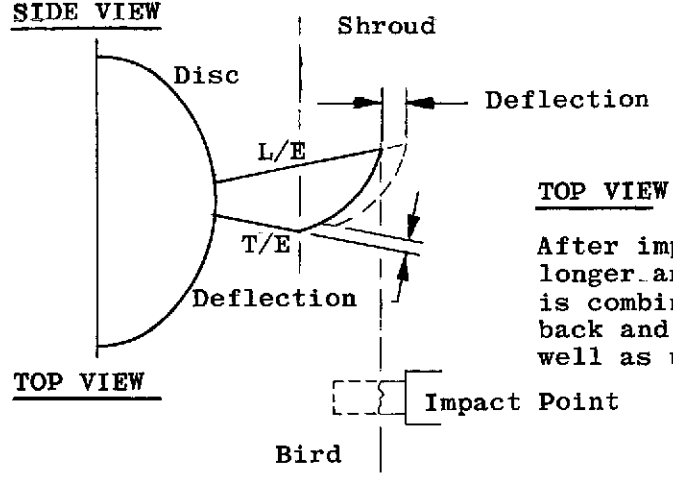

TOP VIEW

After impact blade appears longer and narrower. Deflection is combination of blade bending back and axially forward as well as untwisting.

TOP VIEW

Figure 14. Blade Deflections from High Speed Films.



its inertia. The sliced off portion is grossly broken apart as it engages the blade, but the remainder of the projectile remains remarkably intact and passes by the blade relatively undisturbed.

These facts have been greatly clarified during the present program by the recovery of projectiles after impact. A typical projectile recovered after testing is shown in Figure 15. The sliced plane is clearly shown as the dark region extending from the front of the projectiles, and tapering into the projectile toward the rear. The sharp intersection of the slice-plane with the front surface of the projectile shows the initial projectile "bite" that is set up as an initial test condition.

Projectile characteristics are given in Table VII. The projectile bite size and weight quoted for the composite blades were obtained from recovered projectiles. Values for projectile energies and momenta are presented in Table VIII.

The composite blades were placed under an axial tensile load in order to provide some simulation of the centrifugal force present under engine operating conditions. The apparatus used to effect this loading will be described later.

The values of axial loading were set approximately equal to centrifugal loading imposed on the blade section located four inches below the blade tip. This section lies along the central line of projectile impact. The loads imposed are as follows:

<u>Test No.</u>	<u>Blade Type</u>	<u>Axial Load, Lb.</u>
NG5	Graphite/Epoxy	5500
NB5	Boron/Epoxy	6850

The titanium blade was not tested under an axial load. The apparatus providing axial load was designed to test composite blades only, the motivation being the belief that such materials may be more affected by tensile loading than ductile materials. The apparatus was therefore not designed to accommodate the relatively large blade deflection response of the titanium blades to impact. It was obviously desirable to minimize blade interactions with the apparatus.

Measurement and analysis of triaxial inertial head acceleration histories as well as blade strains was carried out. High speed motion picture records of the tests were also studied and integrated with inertial head data. Program results are presented in a later section.

This page is reproduced at the back of the report by a different reproduction method to provide better detail.

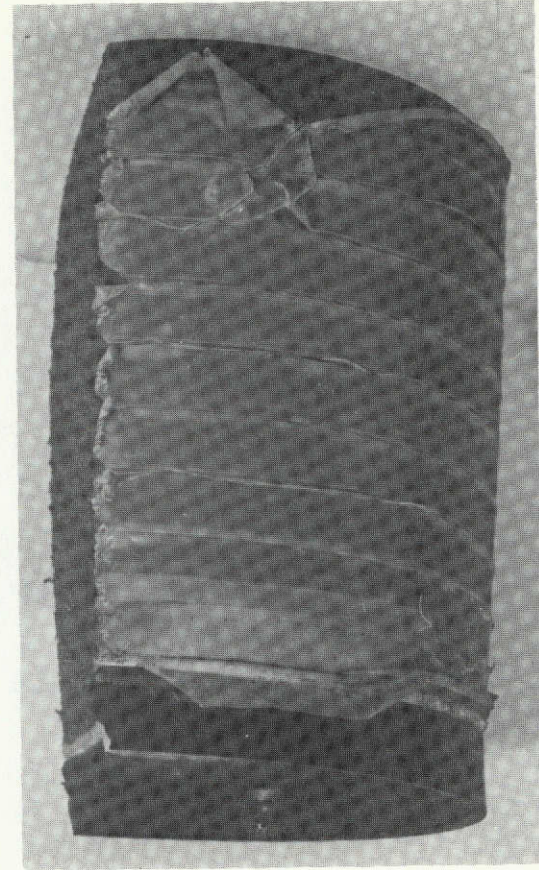
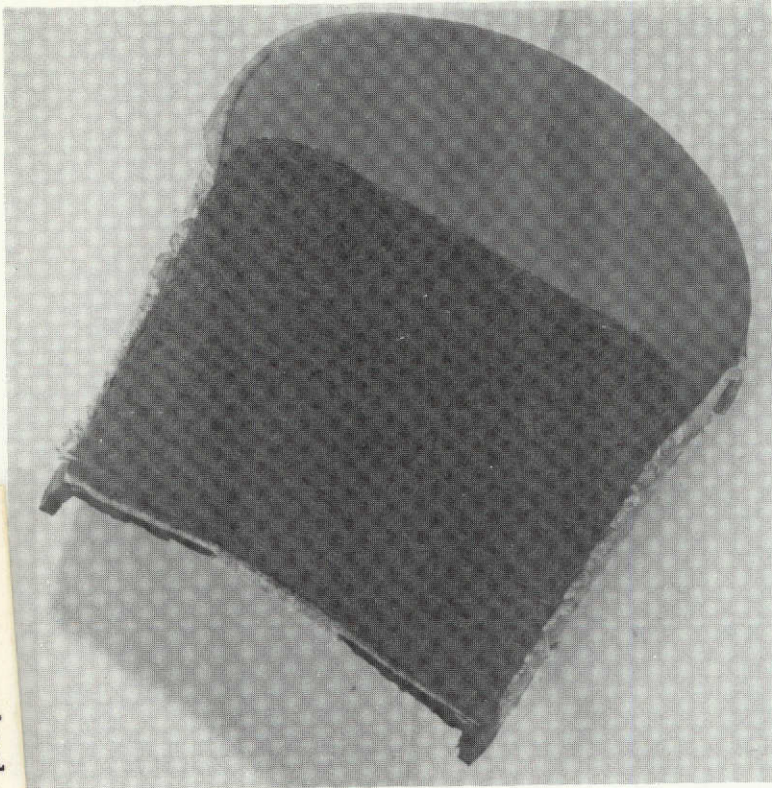

Figure 15. Typical RTV Recovered Projectile after Inertial Head Impacting of Composite Blades.

Table VI. Blade Specimens

Blade S/N	Blade Type	Dovetail Type	Total Wt., Pounds
NG5	Gr/Epoxy Clad LE	Curved	3.241
NB5	B/Epoxy Clad LE	Curved	4.026
Ti2	Titanium	Straight	7.041

Table VII. Projectile Characteristics

Blade S/N	$P_p$ lb/ft <sup>3</sup>	$W_p$ Oz	$L_p$ In.	D In.	$B_n$ In.	$B_a$ In.	$W_b$ Oz.
NG5	46	21.04	1.1	4.00	$1\frac{1}{8}$	1.14	5.12
NB5	46	21.18	1.1	4.00	$1\frac{1}{8}$	1.25	6.52
Ti2	46	21.87	1.1	4.00	$1\frac{1}{8}$	—	>5

$P_p$  - Projectile material density (RTV material)

$W_p$  - Total projectile weight

$L_p$  - Projectile length

D - Projectile diameter

$B_n$  - Nominal projectile bite

$B_a$  - Actual projectile bite

$W_b$  - Weight of projectile part that engages blade

Table VIII. Projectile Energy and Momentum

Test No.	$V_o$ ft/sec	$E_p$ lb ft	$I_p$ lb sec	$E_b$ lb ft	$I_b$ lb sec
STOL 1	790	12760	32.30	3100	7.85
STOL 2	815	13670	33.55	4210	10.3
STOL 3	804	13740	34.19	>3140	>7.82

$V_o$  - Initial impact velocity

$E_p$  - Total projectile kinetic energy

$I_p$  - Total projectile linear momentum

$E_b$  - Kinetic energy of sliced-off projectile portion

$I_b$  - Linear momentum of sliced-off projectile portion

#### 4.3.2 Description of Testing Facilities of Space Sciences Laboratory

The tests were performed in the simulated bird impact facility which features a four inch bore pneumatic gun used to accelerate simulated bird-carcass projectiles to the required velocity and the inertial head apparatus used to obtain quantitative measurements of blade response to impact.

The blades were mounted on an apparatus called the inertial head. The basic feature of this apparatus is that the blade is mounted to a rigid mass which is free to pivot omnidirectionally about a fixed point. The point is very close to the center of gravity of the mass. Upon impact the blade undergoes vibratory motions which cause rotational acceleration of the mass about the pivot point. These accelerations are sensed by a set of accelerometers positioned about three orthogonal axes whose origin is the pivot point (Figure 16). By this means the three components of angular momentum and hence the total angular momentum of the mass may be obtained. The momentum history was related to blade motions by analysis and as a result, the basic motion of the blade itself was inferred. It has been found that quantities such as total momentum, kinetic energy, average impact force, base bending moments, tip deflection, vibration frequencies, and damping constant can be determined by this method.

#### 4.3.3 Inertial Head Centrifugal Load Simulation Device (CLSD)

The Inertial Head Centrifugal Load Simulation Device was designed to produce an axial tension load on the blade so that the blade response to impact could be studied in the presence of axial tensile stresses. This apparatus is shown in Figures 17 and 18.

The axial load is measured by means of two sets of back-to-back strain gages mounted to the major load strap. After load application, these gages are then connected via potentiometer type circuits to monitor the changes in the axial load during the impact test.

#### 4.3.4 Test Results

1) Description of Impacted Blades - The most striking feature of these tests is the generally good appearance of the composite blades after impact. Photographs of the various blades are presented here according to the test number.

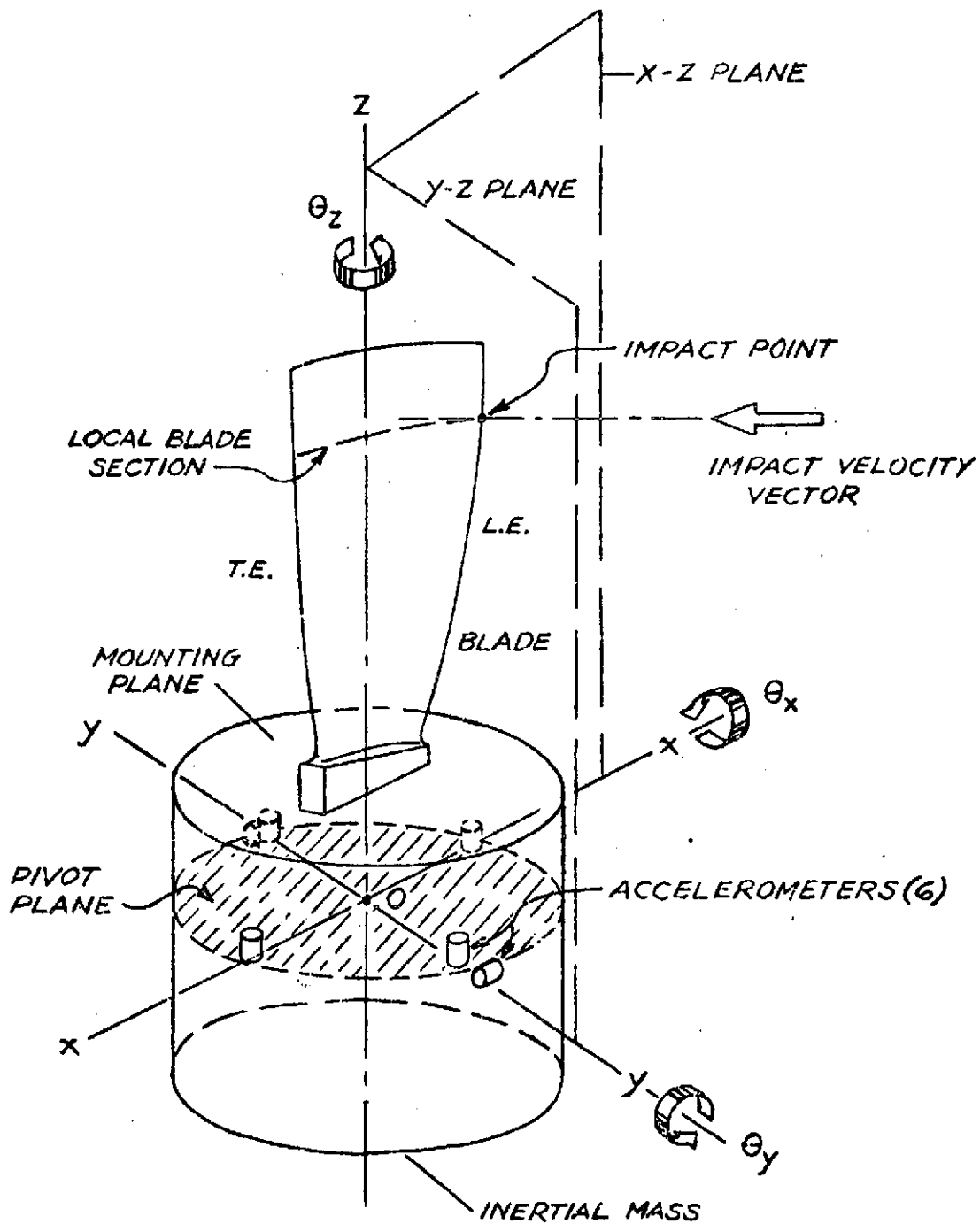

Figure 16. Instrumentation Coordinate system.

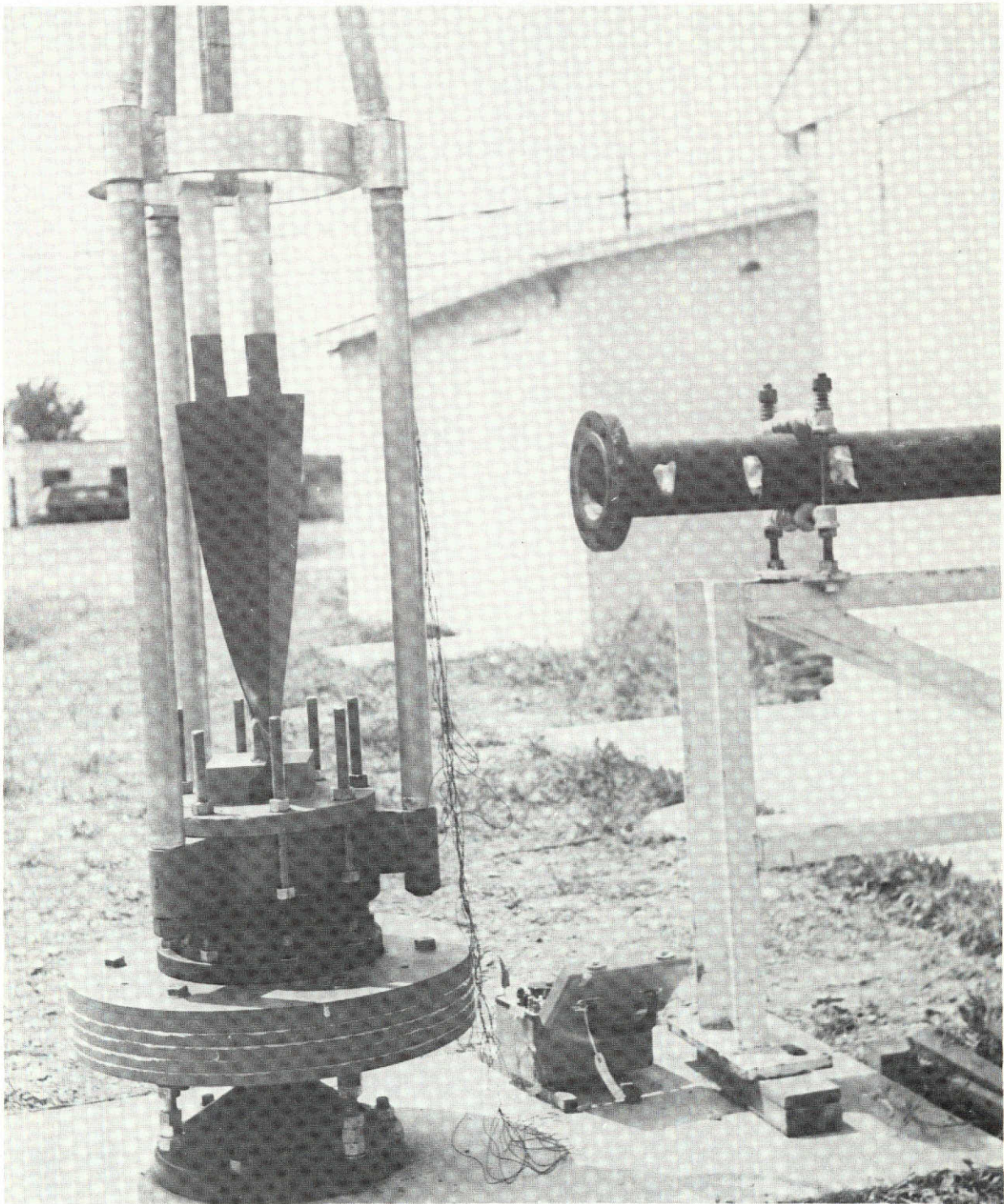

Figure 17. Inertial Head Centrifugal Load Simulation Apparatus.

This page is reproduced at the back of the report by a different reproduction method to provide better detail.

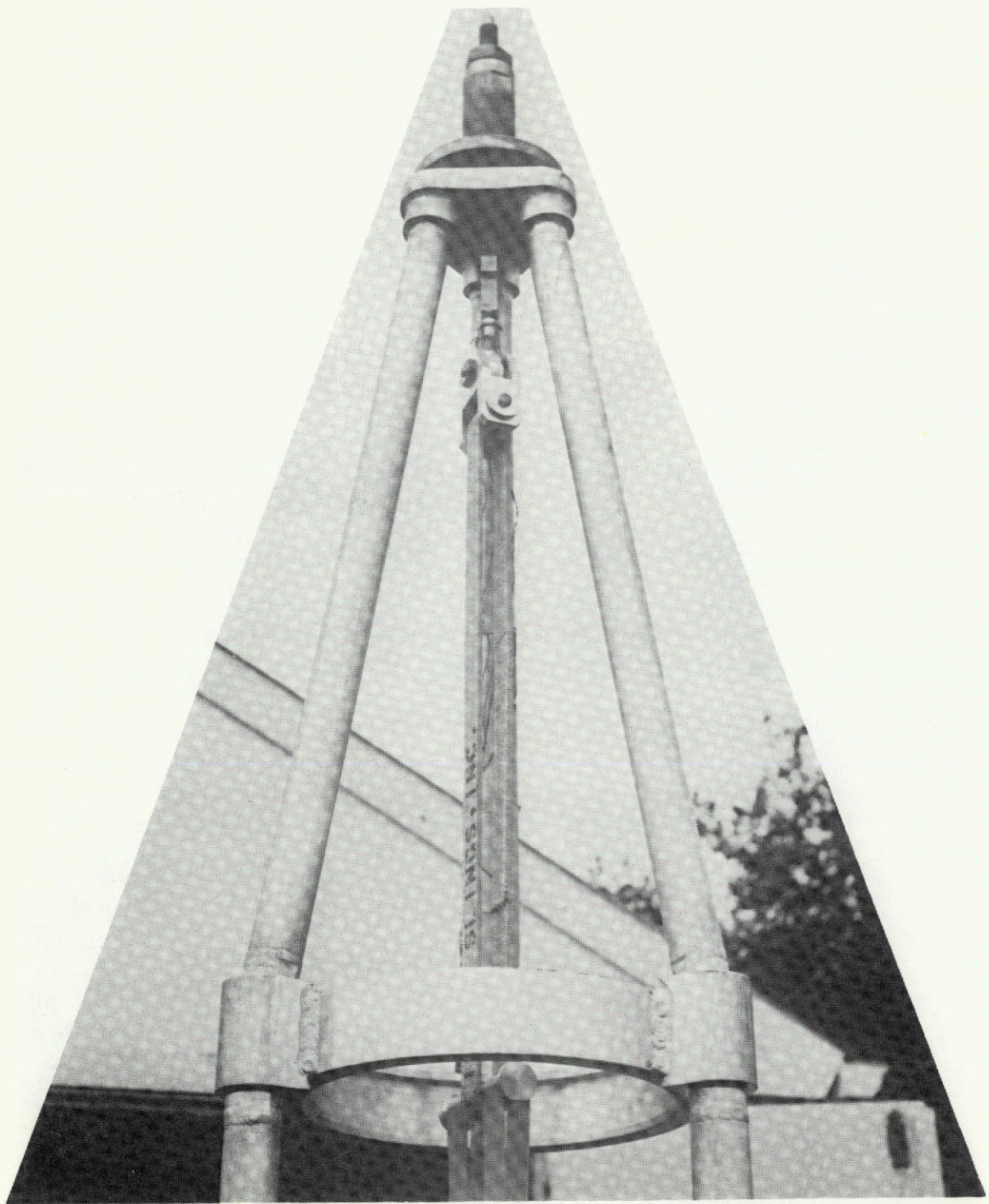

Figure 18. Inertial Head Centrifugal Load Simulation Apparatus.

This page is reproduced at the back of the report by a different reproduction method to provide better detail.



a) NG5 (Graphite/Epoxy)

The specimen is shown in Figure 19 (convex view) and 20 (concave view). The only visible damage to the blade was a rather clean crack extending down from the tip section a distance of less than three inches. The chalk coating can still be seen adjacent to the projectile path (Figure 19) which extended across the entire blade chord. The convex surface of the blade was marked only with short line segments extending back from the leading edge. The lines can be seen clear to the leading edge, demonstrating thereby that no projectile interaction has taken place on the convex surface. The axial load measured after the test showed the same level as before the test.

b) NB5 (Boron/Epoxy)

The boron/epoxy blade is shown after impact in Figures 21 (convex) and 22 (concave). This blade was damaged much more severely than the graphite blade. The principal damage consisted of cracks and multiple delaminations extending down from the tip section and situated again between the loading straps. The damage is especially clear in Figure 22. Similar indications of projectile interaction can be seen here as well.

The strap load after the test was measured as being 5,820 lbs representing a drop off of only 15 percent. Thus, the strap loads were essentially maintained during impact.

c) Ti 2 (Titanium)

The titanium blade impacted in the third test is shown in Figures 23 (convex) and 24 (concave). The blade was not fractured but was perceptively deformed at the leading and trailing edges along the projectile path.

2) Inertial Head Data - Data obtained by integration of inertial head acceleration records are shown in Table IX.

The angular velocity of the inertial head is obtained by direct integration of the accelerometer records. A typical example of these records is shown in Figure 25.

Once the angular velocity of the inertial head is obtained, the value of the initial velocity of the blade center of gravity can be found by analysis. For this, the inertial properties of the system, listed in Table X are needed. The value of  $V$  is found by equating the theoretical value of the inertial head angular velocity, expressed in terms of  $V$ , to the measured value. These values are shown respectively in columns 1 and 2 in Table XI. Once  $V$  is known, the kinetic energy and momentum of the blade produced by the impact are obtained.

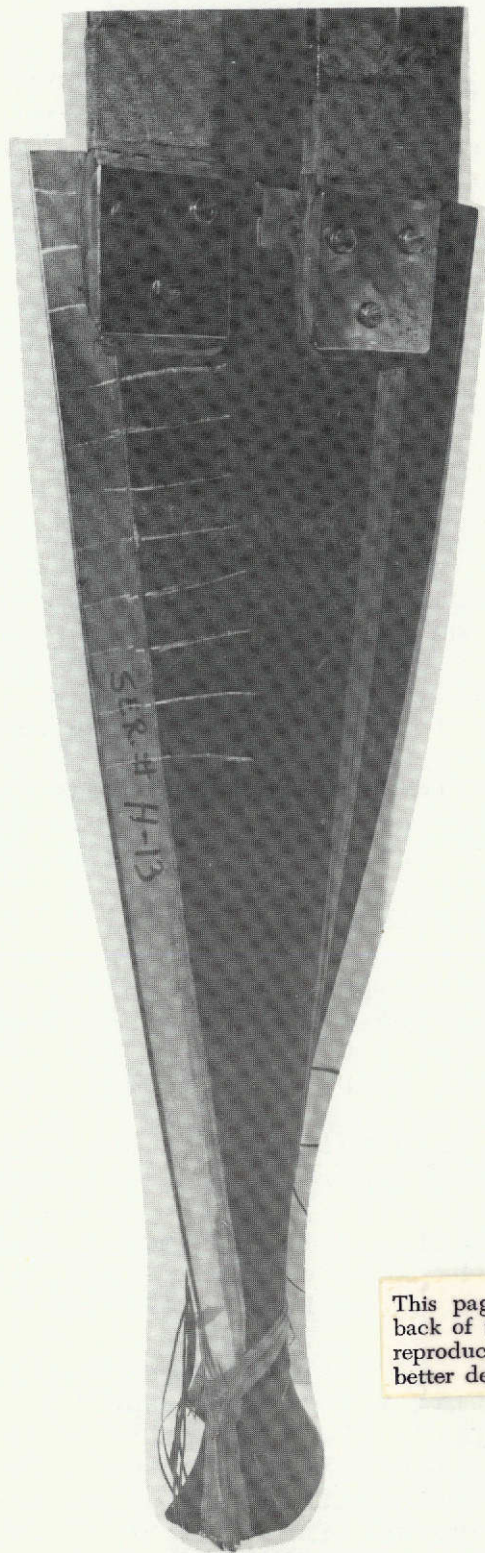

This page is reproduced at the back of the report by a different reproduction method to provide better detail.

Figure 19. NG5 Graphite/Epoxy Blade after Impact (Convex Surface), Test No. STOL 1.

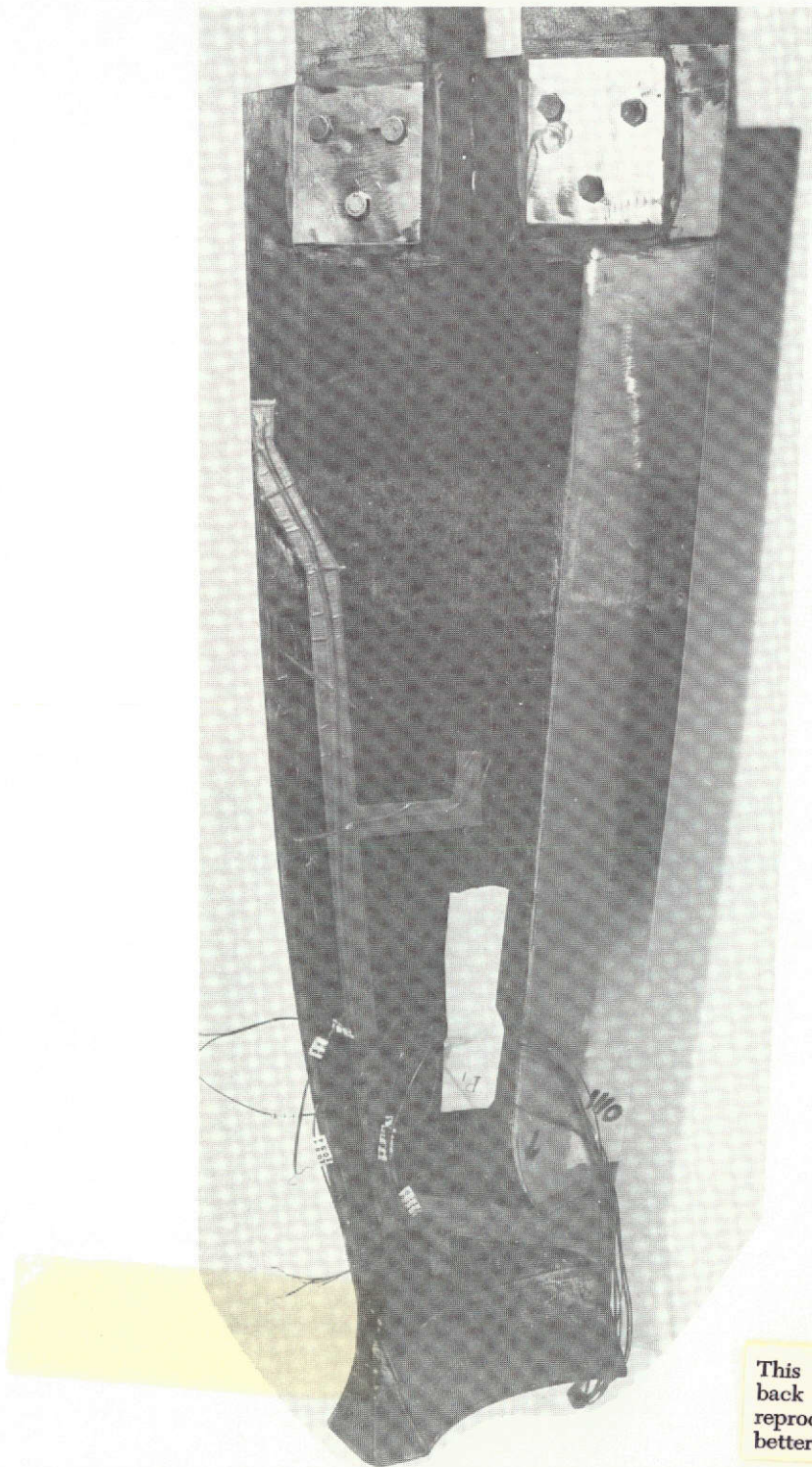

This page is reproduced at the back of the report by a different reproduction method to provide better detail.

Figure 20. NG5 Graphite/Epoxy Blade after Impact (Concave Surface), Test No. STOL 1.

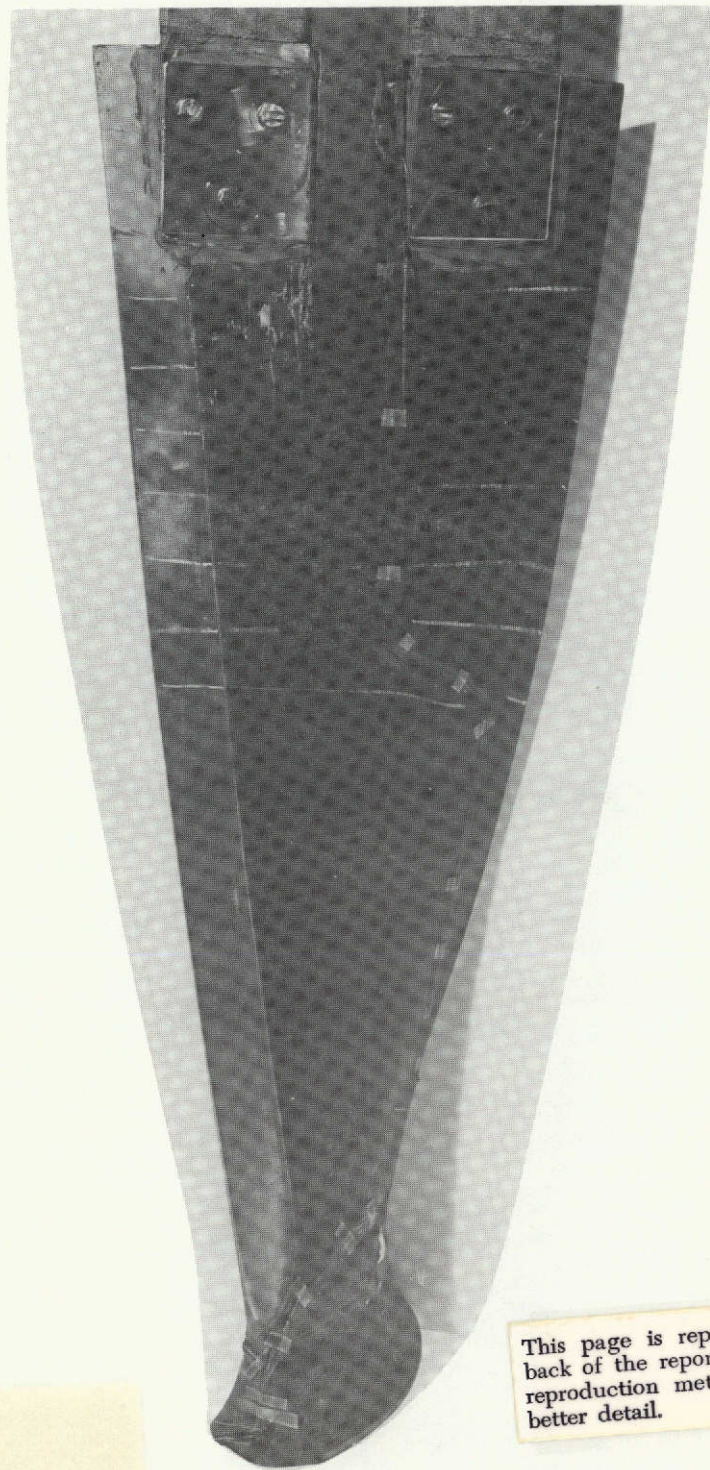

This page is reproduced at the back of the report by a different reproduction method to provide better detail.

Figure 21. NB5 Boron/Epoxy Blade after Impact (Convex Surface), Test No. STOL 2.

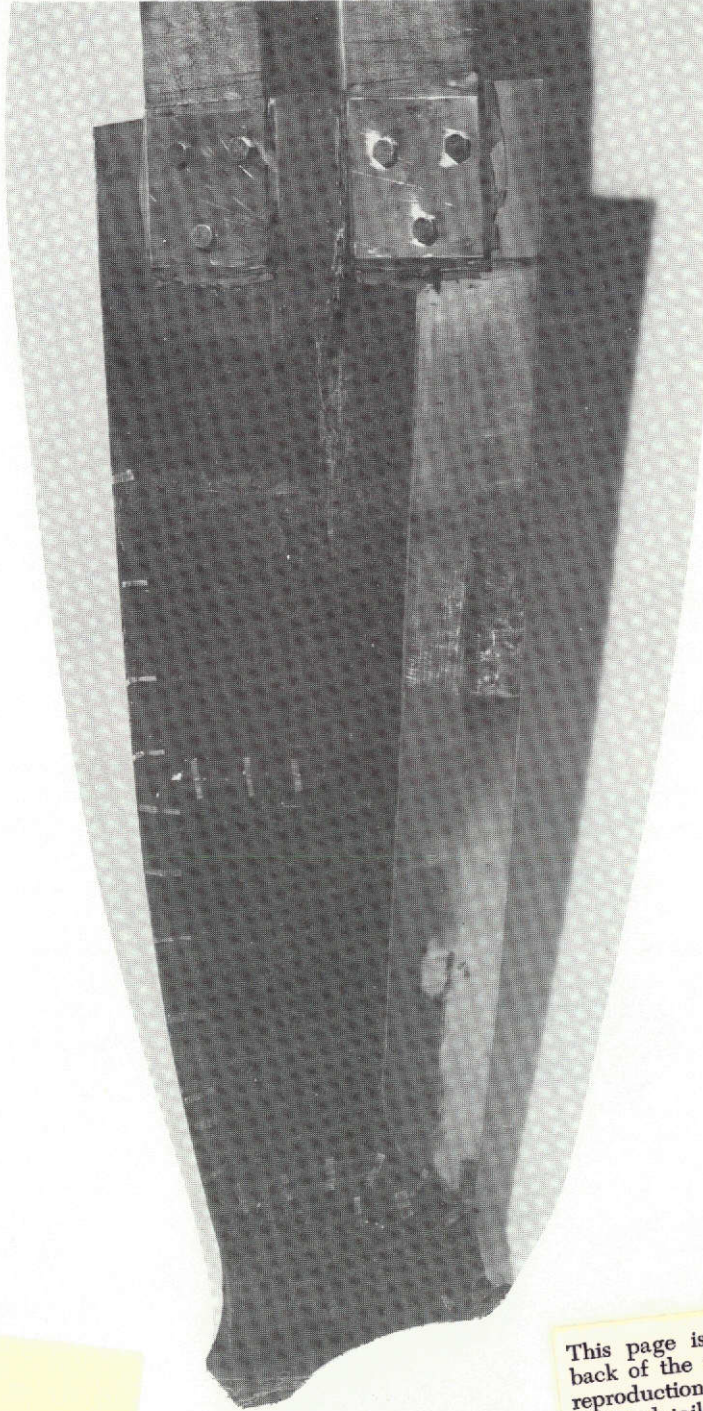

This page is reproduced at the back of the report by a different reproduction method to provide better detail.

Figure 22. NB5 Boron/Epoxy Blade after Impact (Concave Surface), Test No. STOL 2.

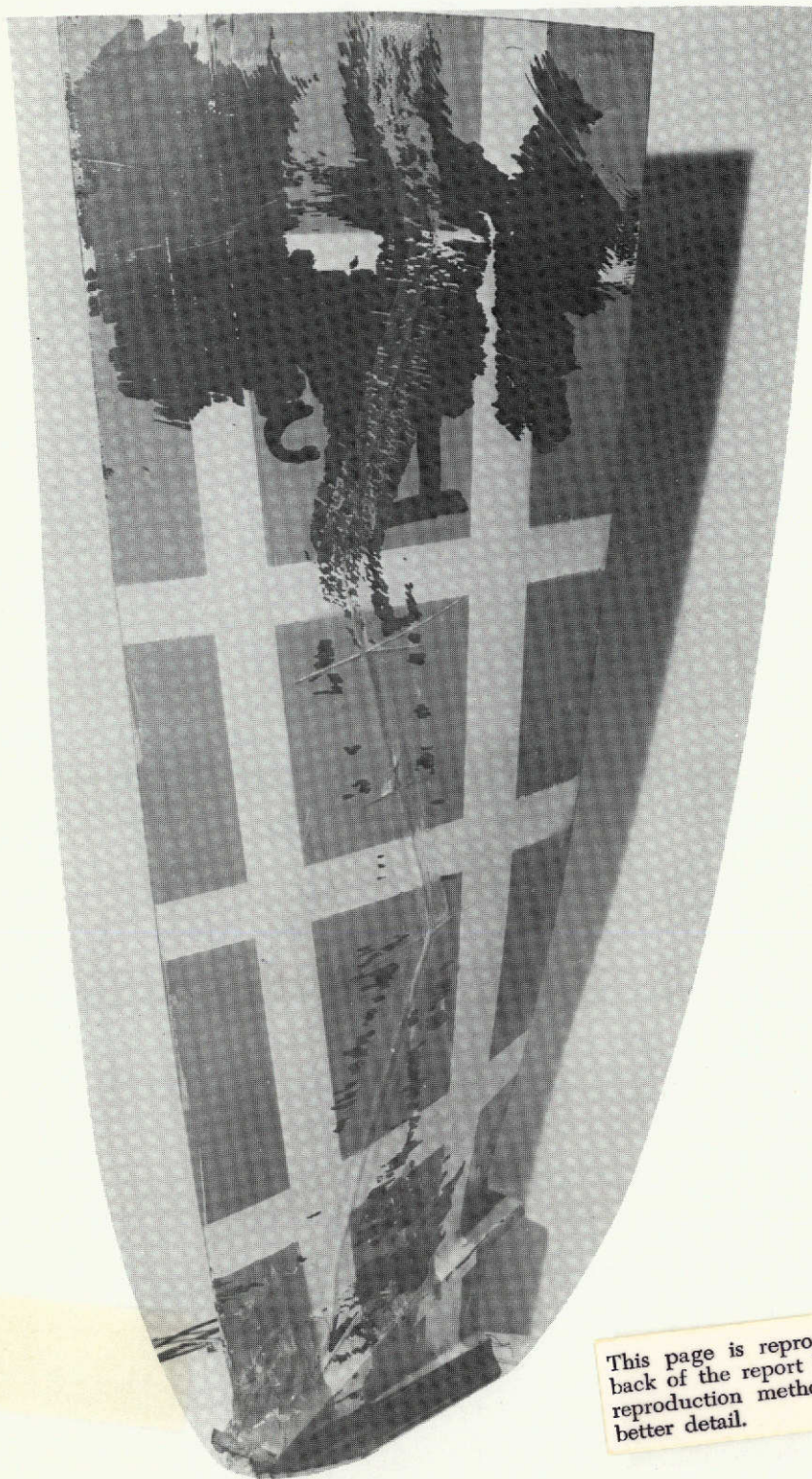

This page is reproduced at the back of the report by a different reproduction method to provide better detail.

Figure 23. Titanium Blade after Impact (Convex Surface), Test No. STOL 3.

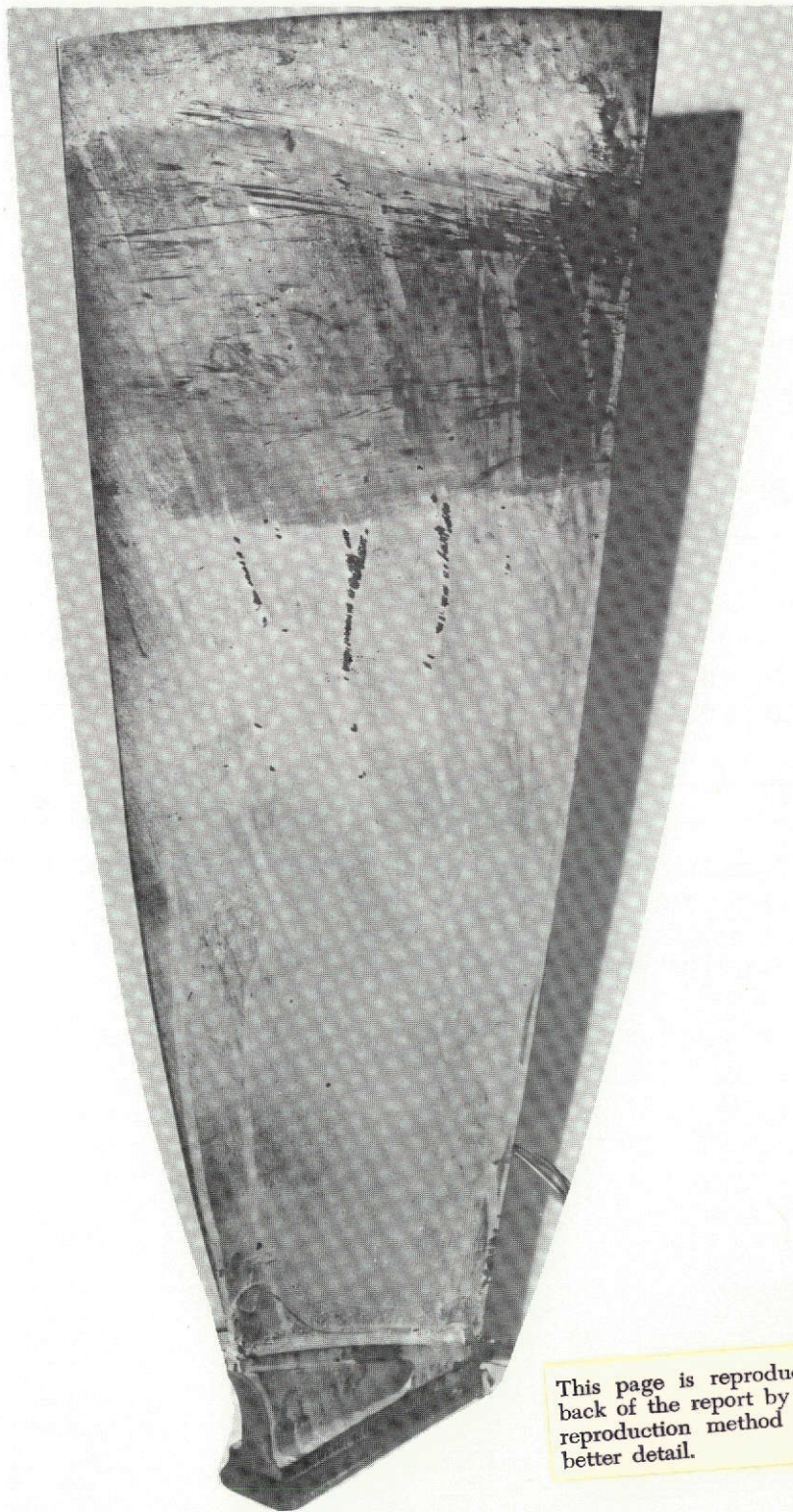

Figure 24. Titanium Blade after Impact  
(Concave Surface), Test No.  
STOL 3.

This page is reproduced at the  
back of the report by a different  
reproduction method to provide  
better detail.

Table IX. Inertial Head Data

Test No.	$W_h$ lb	$J_x = J_y$ lb.ft.sec <sup>2</sup>	$J_z$ lb.ft.sec .	$\dot{\theta}_m$ rad/sec	H lb.ft. sec
NG5	662	10.54	9.49	1.227	12.93
NB5	662	10.54	9.49	1.307	13.78
Ti2	228	1.960	1.200	10.32	20.23

$W_H$  - Weight of rigid mass section of inertial head apparatus

$J_x, J_y, J_z$  - Mass moments of inertia of corresponding inertial head section about x, y, z axes

$\dot{\theta}_m$  - Maximum measured value of angular velocity of the inertial head.

H - Angular momentum corresponding to  $\dot{\theta}_m$ .



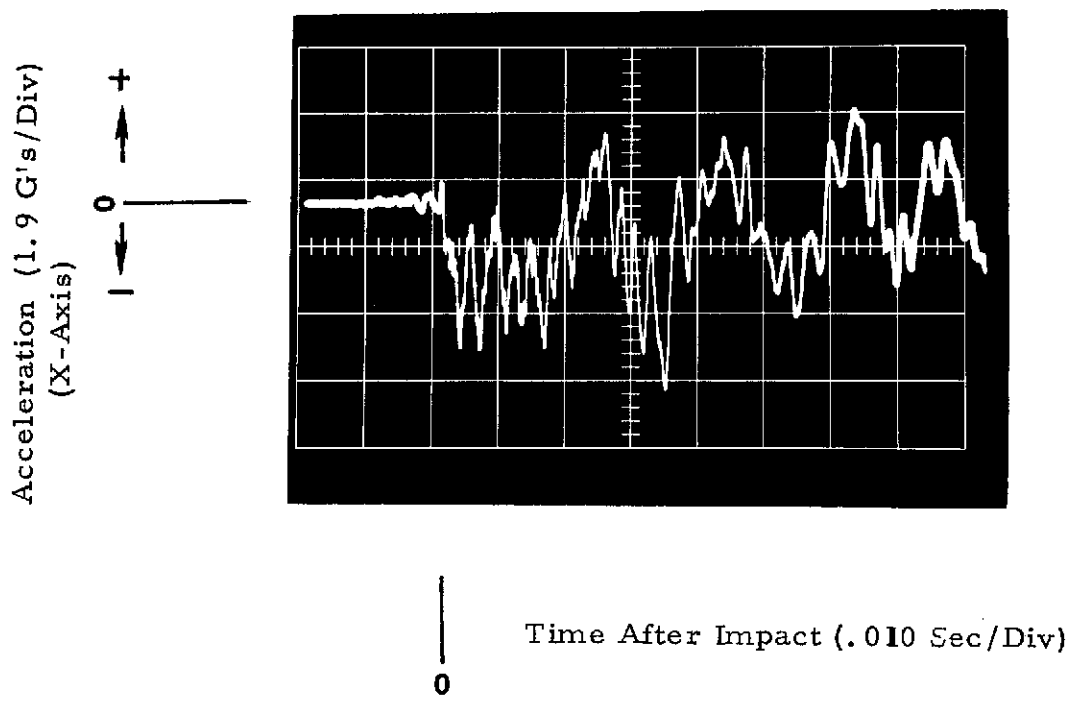
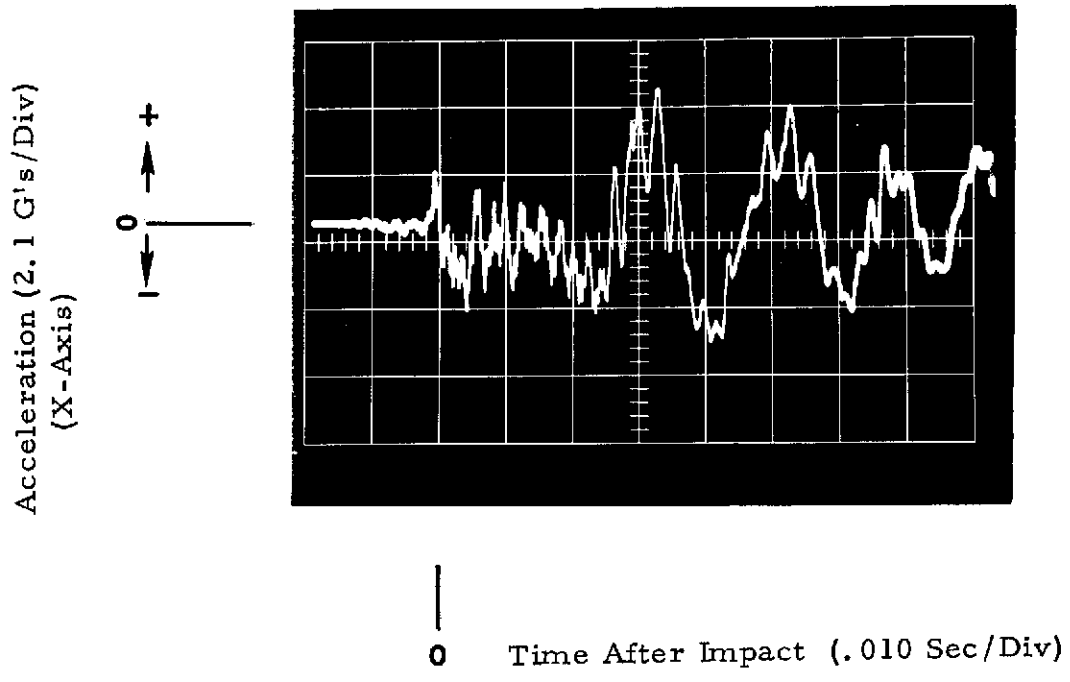

Figure 25. First Cycles of First Flexural Blade. Test Vibration After Beginning of Impact (Boron/Epoxy).

Table X. Blade and System Properties

Test No.	$W_b$ lb	$\ell$ ft	$h$ ft	K	$J_b + M_b \ell^2$ lb-ft-sec <sup>2</sup>
STOL 1	2.466	0.7208	0.5792	0.008673	0.05991
STOL 2	3.063	0.7208	0.5792	0.01076	0.07442
STOL 3	6.57	0.6900	0.4842	0.10550	0.1508

$W_b$  - Weight of blade airfoil section above reference plane PA, as used in GE/AEG drawings.

$\ell$  - Distance between plane PA and blade center of gravity.

$h$  - Distance between plane PA and inertial head pivot point 0.

K - Ratio of the head/blade inertial stiffness about the pivot point.

$J_b + M \ell^2$  - Mass moment of inertia of blade about axis parallel to dovetail axis at plane PA.

Table XI. Kinetic Energy and Momentum Transferred to Blade

Test No.	$\dot{\theta} \frac{V}{\ell}$	$\dot{\theta}_m$ rad/sec	V ft/sec	I lb-sec	E lb-ft
NG5	0.01720	1.227	51.4	5.93	152.4
NB5	0.02129	1.307	44.2	6.34	140.2
Ti	0.19086	10.32	37.3	11.81	220.4

$\left(\dot{\theta} \frac{V}{\ell}\right)$  - Theoretical value of dimensionless inertial head angular velocity at:  
time  $t = \frac{T}{2}$  where T is the period of first flexural blade vibration.

$\dot{\theta}_m$  - Maximum integrated (measured) value of head velocity.

$$E = \frac{1}{2} \left( \frac{J_b}{\ell^2} + M \right) v^2$$

$$I = \left( \frac{J_b}{\ell^2} + M \right) v^2$$

The values for V, I, and E are also listed in Table XI.

## 5.0 TASK III - FOREIGN DAMAGE EVALUATION

After impact testing the blades were removed from the rotating arm rig and photographed to make a permanent record of the damage sustained. The composite blades were nondestructively tested by appropriate methods to determine internal damage. Due to the extent of damage only the first flexural frequency was determined after impact.

### 5.1 Nondestructive Evaluation of Impact Damage

Blade S/N NG3 12 Oz RTV	No NDT evaluation--too severely damaged.
Blade S/N NG2 Gravel, Ice Balls	No visible damage. TTUCS* indicated small debonded area along leading edge (LE) protection. Remaining airfoil undamaged. Dye penetrant inspection did not reveal any cracks or delaminations in the dovetail (D/T) after impact. Velocity measurements confirmed TTUCS data. No loss in velocity was noted as a result of impact.
Blade S/N NG4 11 Oz Pigeon	Visible damage - Splintered at the trailing edge (TE) tip; severe root damage. TTUCS shows large delamination area running from D/T to midway up the blade. Tip badly delaminated also. Dye penetrant inspection showed delamination crack running around entire D/T. Velocity measurements show reduced values over entire blade section after impact indicating internal damage.
Blade S/N NG1 6 Oz RTV	Visible damage - Piece missing from TE tip; crack in D/T slight separation of nickel from LE. TTUCS reveals delamination area at base plus damage at TE tip. Delamination in D/T can be seen in photos of dye penetrant check. Low velocity measurements were recorded at the base of the blade, trailing edge side, indicating internal damage. A decrease in velocity readings after impact was also observed in the tip region indicating some damage.

\*TTUCS (Thru Transmission Ultrasonic C Scan)

Blade S/N NB4  
12 Oz RTV

No NDT evaluation--too severely damaged. Blade broke off at root.

Blade S/N NB1  
Gravel, Ice  
Balls

Visible damage - slight crack at the TE tip; crack along LE protection. TTUCS showed delamination area at base of blade after impact. Dye penetrant inspection of the D/T revealed a crack along the LE. Reduced velocity values at base of blade indicate delamination—confirming TTUCS data.

Blade S/N NB2  
6 Oz RTV

Visible damage - tip cracked at TE and LE delamination at base of LE protection - concave side. TTUCS shows a delaminated area at the base of the blade after impact, probably in center plies. Crack on LE can be seen in photo. A decrease in velocity was observed at the base of blade after indicating unbonded area.

Blade S/N NB3  
10 Oz Pigeon

Visible damage - tip delaminated across blade; delamination at base of LE. TTUCS after impact indicates blade has internal damage throughout. The D/T had cracks in both the LE and TE as shown by dye penetrant checks. Reduced velocity measurements were obtained over the entire blade surface after impact confirming the TTUCS data.

## 6.0 CONCLUSIONS AND RECOMMENDATIONS

The whirligig impact testing conducted in the course of completing this program has demonstrated the ability to control the bird impact conditions very closely. This was accomplished by the use of a sophisticated bird injecting mechanism which allowed birds of varying sizes both real and simulated to be injected into the path of a single rotating blade. The control of the bird slice was held within 1 oz of the desired amount.

The test results indicate the following:

- The threshold level of bird slice which results in local damage is between 5 to 6 oz. This is based on results of ice ball tests and 6 oz. bird tests.
- The threshold level of bird slice which results in bending failure of the blade, for both graphite/epoxy and boron/epoxy composite blades is approximately 12 oz.
- The metallic titanium blade suffered essentially no damage when impacted with an 8 oz slice of a real pigeon.
- Simulated RTV bird impact conditions are slightly more severe than that of real birds for the same bite size.
- Strain gage data obtained from whirligig impact tests appear to be consistent and realistic for bird impacts less than 8 oz. For bird sizes near the threshold level (12 oz) the strain gage readings are less reliable.
- The mode of failure observed during inertial head testing is slightly different from whirligig results with damage taking place in between the loading straps. The blade stiffness in the tip region is somewhat unnatural due to the strap attachment and reinforcement method used. It is recommended that future testing in the inertial head apparatus be performed without centrifugal loading.
- It is recommended that further whirligig impact tests be conducted on composite blades of various hybrid configurations to develop a more bird resistant composite blade.

## 7.0 APPENDIX

Acceptance sheets for a typical composite blade being considered for NASA Impact Testing.





E - ENGINEERING  
M - M&PTL  
Q - QUALITY ASSURANCE

ACCEPTANCE CRITERIA REVIEW SHEET

BLADE SERIAL NUMBER \_\_\_\_\_  
REVIEW DATE \_\_\_\_\_ (initial)  
FINAL \_\_\_\_\_

ITEM	CRITERIA	REVIEW BOARD DIAGNOSIS									REMARKS
		ACCEPT			PENDING			REJECT			
		E	M	Q	E	M	Q	E	M	Q	
5.	Dimensional Inspection <ul style="list-style-type: none"> <li>• Aerodynamic Contours</li> <li>• Twist</li> <li>• Lean</li> <li>• Root</li> <li>• Wear Band</li> <li>• Plating</li> <li>• Polyurethane</li> <li>•</li> </ul>										
6.	Nondestructive Evaluation <ul style="list-style-type: none"> <li>• Holographic               <ul style="list-style-type: none"> <li>. Blade Form</li> <li>. Root Area</li> </ul> </li> <li>• Ultrasonic               <ul style="list-style-type: none"> <li>. Blade Form</li> <li>. Root Area</li> </ul> </li> <li>• Dye Penetrant               <ul style="list-style-type: none"> <li>. Root Area</li> </ul> </li> <li>• Frequency               <ul style="list-style-type: none"> <li>. First Flex.</li> <li>. Second Flex.</li> <li>. First Torsion</li> </ul> </li> </ul>										

SUMMARY:

REVIEW BOARD ANALYSIS

Initial Analysis

(Prior to plating and polyurethane)

Initial Analysis Grading \_\_\_\_\_

Selected for Test (Type) \_\_\_\_\_

Review Board Signatures:

Engineering \_\_\_\_\_

M&PTL \_\_\_\_\_

Quality Assurance \_\_\_\_\_

Final Analysis

(Prior to dispatch)

Final Grading \_\_\_\_\_

Allocated to Test (Type) \_\_\_\_\_

Review Board Signatures:

Engineering \_\_\_\_\_

M&PTL \_\_\_\_\_

Quality Assurance \_\_\_\_\_

THE FOLLOWING PAGES ARE DUPLICATES OF  
ILLUSTRATIONS APPEARING ELSEWHERE IN THIS  
REPORT. THEY HAVE BEEN REPRODUCED HERE BY  
A DIFFERENT METHOD TO PROVIDE BETTER DETAIL