

X-552-71-170

PREPRINT

NASA TM X-70607

ANALYSIS OF IONOSPHERIC REFRACTION ERROR CORRECTIONS FOR GRARR SYSTEMS

(NASA-TM-X-70607) ANALYSIS OF IONOSPHERIC
REFRACTION ERROR CORRECTIONS FOR GRARR
SYSTEMS (NASA) 27 p HC \$4.50 CSCL 04A
28

74-19024

Unclas
32727

G3/13

A. J. MALLINCKRODT
H. C. PARKER
J. H. BERBERT

APRIL 1971

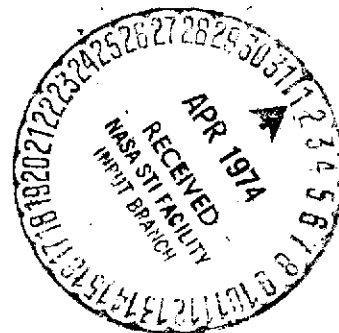

— GODDARD SPACE FLIGHT CENTER —
GREENBELT, MARYLAND

**For information concerning availability
of this document contact:**

**Technical Information Division, Code 250
Goddard Space Flight Center
Greenbelt, Maryland 20771**

(Telephone 301-982-4488)

ANALYSIS OF IONOSPHERIC
REFRACTION ERROR CORRECTIONS
FOR
GRARR SYSTEMS

A. J. Mallinckrodt
Communications Research Laboratories
Santa Ana, California
Contract No. NAS5-21728

H. C. Parker
RCA Service Company
Contract No. NAS5-10600

J. H. Berbert
GEOS Observation Systems Intercomparison Investigation
Goddard Space Flight Center
Greenbelt, Maryland

April 1971

GODDARD SPACE FLIGHT CENTER
Greenbelt, Maryland

ANALYSIS OF IONOSPHERIC REFRACTION
ERROR CORRECTIONS FOR GRARR SYSTEMS

A. J. Malinckrodt, H. C. Parker, J. H. Berbert

ABSTRACT

This report presents a determination of the ionospheric refraction correction requirements for the Goddard Range and Range Rate (GRARR) S-band, modified S-band, very high frequency (VHF), and modified VHF systems. The relationships within these four systems are analyzed to show that the refraction corrections are the same for all four systems and to clarify the group and phase nature of these corrections. The analysis is simplified by recognizing that the range rate is equivalent to a carrier phase range change measurement. The range errors may be expressed

$$\Delta R = \pm \frac{K}{f_{eq}^2}$$

where the + sign pertains to modulation range and the - sign to carrier range, and where the equivalent frequencies are

$$\frac{1}{f_{eq}^2} = \frac{1}{2} \left(\frac{1}{f_u^2} + \frac{1}{f_d^2} \right) \quad (\text{modulation})$$

$$\frac{1}{f_{eq}^2} = \frac{1}{2} \left(\frac{1}{f_u^2} + \frac{1}{f_d^2} + \frac{f_L - f_u}{f_u} \frac{2}{f_d^2} \right) \quad (\text{carrier})$$

$$\approx \frac{1}{2} \left(\frac{1}{f_u^2} + \frac{1}{f_d^2} \right)$$

where

f_u = up link frequency

f_d = down link frequency

f = transponder local oscillator frequency

TABLE OF CONTENTS

ANALYSIS OF IONOSPHERIC REFRACTION ERROR
CORRECTIONS FOR GRARR SYSTEMS

<u>Section</u>	<u>Page</u>
Abstract	iii
1. Introduction	1
2. Phase and Group Retardation	1
3. Derivation of System Equations	3
4. Range and Range Rate Extraction and Equivalent Frequencies	6
5. Relation to Prior Formulation for Equivalent Frequency . .	10
6. Other Transponder-receiver System Configurations	11
7. Simultaneous use of Carrier and Modulation Measurements to Infer Ionospheric Correction	11

LIST OF ILLUSTRATIONS

<u>Figure</u>	<u>Page</u>
1 S-Band System, Simplified Diagram	16
2 VHF System, Simplified Diagram	18
3 Modified S-Band System, Simplified Diagram	20
4 Modified VHF System, Simplified Diagram	22

LIST OF TABLES

<u>Table</u>	<u>Page</u>
1 S-Band System Equations	15
2 VHF System Equations	17
3 Modified S-Band System Equations	19
4 Modified VHF System Equations	21

ANALYSIS OF IONOSPHERIC REFRACTION ERROR
CORRECTION FOR GRARR SYSTEMS

1. INTRODUCTION

The Goddard Range and Range Rate (GRARR) system is a spacecraft tracking system which uses a combination of phase and group ranging techniques.

Range measurements are accomplished using the basic sidetone ranging technique where the phase delay of a ranging sidetone frequency is directly proportional to the two-way range between the tracking antenna and the spacecraft. Range rate measurements are made using the established principles of coherent Doppler. To determine the Doppler frequency, frequency coherence of the ground transmitter carrier frequency is maintained through the spacecraft transponder and back to the ground receiver where it is compared in frequency against a coherent sample of the transmitter frequency.

The GRARR system exists in two versions, one operating at S-band and one operating at VHF. Also, the GRARR stations have been modified so there are essentially four different systems: S-band, modified S-band, VHF, and modified VHF. Ionospheric refraction error correction requirements will be determined for each of the four systems. Simplified diagrams of the four systems are shown in Figures 1 through 4. The diagrams for the S-band and VHF systems were obtained from References 1 and 3, for the modified S-band and VHF systems, from Reference 2.

There has been some confusion as to the exact formulation of the ionospheric correction for GRARR measurements (Reference 4). This confusion arose because of the rather involved nature of the ranging modulation system and uncertainty between group and phase treatment. This document is intended to resolve that uncertainty by a very careful analysis of basic principles.

2. PHASE AND GROUP RETARDATION

In the ionosphere at the frequencies of interest, it is an adequate approximation to represent the ionospheric range error as inversely proportional to the square of the frequency. Thus, a pure sinusoidal or carrier transmitted signal may be written in complex form as

$$e_1(t) = \text{Re} \left\{ \exp [j2\pi ft] \right\} \quad (1)$$

where

f = frequency (Hz)

t = propagation time

After traveling a distance R , which includes some amount of ionosphere, the received signal may be written

$$e_2(t) = \text{Re} \left\{ \exp \left[j2\pi f(t - r_p) \right] \right\}$$

where approximately for the ionosphere at frequencies above about 100 MHz

$$r_p = \frac{1}{c} \left[R - \frac{K}{f^2} \right] = \text{phase transit delay (see Reference 4)} \quad (3)$$

c = vacuum speed of light

K is proportional to the total electron content along the path (Reference 5)

$$K = 40.3 \int_{\text{path}} n_e ds, \left[\text{meter (Hz)}^2 \right] \quad (4)$$

where n_e = electron density, e/m^3

If the transmitted signal is modulated by any kind of relatively narrowband signal, $m(t)$, it can be represented as

$$e_1(t) = \text{Re} \left\{ \exp(j2\pi ft) \exp m(t) \right\} \quad (5)$$

where $m(t)$ may, in general, be complex to represent amplitude modulation, phase modulation, or both. Then, as shown in Reference 5, irrespective of the form or nature of the modulation, the received signal may be written

$$e_2(t) = \text{Re} \left\{ \exp \left[j2\pi f(t - r_p) \right] \exp \left[m(t - r_g) \right] \right\} \quad (6)$$

where r_g = group transit delay (7)

$$= \frac{d}{df} (f r_p)$$

For the ionosphere in particular, with r_p as given by equation 3,

$$r_g = \frac{1}{c} \left[R + \frac{K}{f^2} \right] \quad (8)$$

which differs from r_p only in the sign of the ionospheric term. The relations of equations 3, 7, and 8 are used extensively in the following paragraphs to derive

the exact ionospheric error dependence of the modulation and carrier phase measurements for each of the four GRARR systems.

3. DERIVATION OF SYSTEM EQUATIONS

For brevity in the following, we adopt a useful shorthand. Phases are expressed in millions of cycles (Mc) so that the phase of a 10-MHz oscillator is denoted by $10t$. A phase modulated wave such as

$$A \sin [\omega_c t + \beta \sin(\omega_m t)]$$

is written simply in terms of its carrier and modulation phases in Mc as

$$\frac{\text{carrier}}{f_c t} \qquad \frac{\text{modulation}}{f_m t}$$

In some cases, we will deal with doubly modulated signals

$$A \sin \{ \omega_c t + \beta \sin [\omega_m t + \gamma \sin \omega_s t] \}$$

which is written simply as

$$\frac{\text{carrier}}{f_c t} \qquad \frac{\text{modulation}}{f_m t} \qquad \frac{\text{modulation-on-modulation}}{f_s t}$$

In accordance with the foregoing conventions, group and phase transit time delays are

$$P_u = \frac{1}{c} \left[R - \frac{K}{f_u^2} \right] \qquad P_d = \frac{1}{c} \left[R - \frac{K}{f_d^2} \right]$$

$$G_u = \frac{1}{c} \left[R + \frac{K}{f_u^2} \right] \qquad G_d = \frac{1}{c} \left[R + \frac{K}{f_d^2} \right]$$

where f_u, f_d = up and down carrier frequencies

K = ionospheric range error (positive) normalized to unit frequency.

Thus, all carrier terms suffer transit delay P_u or P_d and all modulation or modulation-on-modulation terms suffer transit delay G_u or G_d , as appropriate.

The derivation for the S-band system is diagramed in Figure 1. The following notes are keyed to the signal equations at designated points in this figure and to the shorthand notation of these equations as presented in Table 1.

- ① This is the shorthand notation for the transmitted signal,

$$A \sin(2\pi f_u t + \beta \sin 2\pi f_s t)$$

- ② The signal arrives at the satellite with time delays P_u and G_u on the carrier and modulation signals.
- ③ The received signal is converted to a low IF by heterodyning with the oscillator, Mf_o .
- ④ The entire resulting low IF signal is used to phase modulate a new carrier, Nf_o . Thus the old, carrier ③ becomes modulation and the old modulation becomes modulation on modulation.
- ⑤ The signal arrives at the ground with the down link delays P_d and G_d .
- ⑥ This is the $N \times$ VCO of a phase-lock-loop, locked to an effective 60-MHz reference. As such, it does not track any of the modulation but insures that the next IF signal will be 60 MHz. By tracing around the phase-locked loop, it is seen that $\bar{\Phi}_6$ must satisfy (denoting average or carrier phases by the overbar):

$$\bar{\Phi}_5 - \bar{\Phi}_6 - 50t = 10t$$

$$\text{or } \bar{\Phi}_6 = \bar{\Phi}_5 - 60t = Nf_o(t - P_d) - 60t$$

and subsequently $\bar{\Phi}_7$ must satisfy

$$\bar{\Phi}_7 = \bar{\Phi}_5 - \bar{\Phi}_6 = \bar{\Phi}_5 - (\bar{\Phi}_5 - 60t) = 60t$$

- ⑦ From ⑥, the carrier phase of ⑦ is just $60t$, the modulation is, of course, unchanged.

⑧
$$\begin{aligned} \Phi_8 &= \Phi_6/N \\ &= (\bar{\Phi}_5 - 60t)/N \\ &= (f_o - \frac{60}{N})t - f_o P_d \end{aligned}$$

- ⑨ After this phase demodulator, the old modulation ⑦ becomes the carrier and the old mod-on-mod is the new modulation.

- ⑩ This is another phase-lock-loop serving simply to translate the carrier at ⑨ to exactly 10 MHz for phase demodulation, ($\Phi_{10} = \bar{\Phi}_9 + 10t$).
- ⑪ This is the final group demodulation which is phase compared with the original signal or modulating frequency f_s to give ⑫
- ⑫ the phase of the group signal (used for the range measurement).

Meanwhile,

- ⑬ derives the appropriate carrier bias frequency with $\Phi_{13} = -\left(\frac{f_u t}{M} - \Phi_8\right) M + 90.5t$, so that at
- ⑭ we have the carrier Doppler term on a bias frequency, f_B , which has been derived solely from the ground receiver frequency synthesizer, that is, the bias frequency reference is available. ($\Phi_{14} = \Phi_{13} - \Phi_{10}$).

Equations 12 and 14 constitute the group and phase (or modulation and carrier) measurement signals for extraction of range and range rate.

The analysis of the other cases is straightforward and follows a similar pattern.

4. RANGE AND RANGE RATE EXTRACTION AND EQUIVALENT FREQUENCIES

The modulation phase measurement (M_m) is used for range extraction. In each of the four GRARR systems M_m in millions of cycles is found to be of the form

$$M_m = f_s (G_u + G_d) \quad (9)$$

where

$$f_s = \text{modulating signal frequency}$$

$$G_u = \frac{1}{c} \left[R + \frac{K}{f_u^2} \right] = \text{up group transit time}$$

$$G_d = \frac{1}{c} \left[R + \frac{K}{f_d^2} \right] = \text{down group transit time}$$

f_u, f_d = up and down carrier frequencies

K = ionospheric range error normalized to unit frequency, ($K > 0$)

thus

$$M_m = \frac{2f_s}{c} R + \frac{f_s K}{c} \left[\frac{1}{f_u^2} + \frac{1}{f_d^2} \right] = \frac{2f_s}{c} R + \frac{2f_s K}{cf_m^2} \quad (10)$$

where f_m is the equivalent frequency for modulation given by

$$\frac{1}{f_m^2} = \frac{1}{2} \left[\frac{1}{f_u^2} + \frac{1}{f_d^2} \right] \quad (11)$$

The form of the apparent range equation is given by solving equation 10 for range in the absence of ionosphere errors ($K=0$):

$$R_m^* = \frac{c}{2f_s} M_m$$

Then the apparent range for $K \neq 0$ is:

$$R_m^* = R + \frac{K}{f_m^2} \quad (12)$$

Equation 12 is solved to provide the corrected range measurement

$$R = R_m^* - \frac{K}{f_m^2} \quad (13)$$

Similarly, the carrier phase measurements (M_c) are used for range rate extraction and are all of the form

$$M_c = f_B t - f_L (P_d - G_d) - f_u (P_u + G_u) \quad (14)$$

where

f_B = Bias frequency, see Tables 1 through 4

$$P_u = \frac{1}{c} \left[R - \frac{K}{f_u^2} \right] = \text{up phase transit time}$$

$$P_d = \frac{1}{c} \left[R - \frac{K}{f_d^2} \right] = \text{down phase transit time}$$

$$f_L = Mf_o = \text{transponder first local oscillator frequency}$$

therefore

$$M_c = f_B t - \frac{2f_u}{c} R + \frac{Kf_u}{c} \left[\frac{1}{f_u^2} - \frac{1}{f_d^2} + \frac{2f_L}{f_u f_d^2} \right]$$

$$= f_B t - \frac{2f_u}{c} R + \frac{Kf_u}{c} \left[\frac{1}{f_u^2} + \frac{1}{f_d^2} + \frac{f_L - f_u}{f_u} \frac{2}{f_d^2} \right]$$

$$= f_B t - \frac{2f_u}{c} R + \frac{2Kf_u}{c f_c^2} \quad (15)$$

where f_c is the equivalent frequency for the carrier given by

$$\frac{1}{f_c^2} = \frac{1}{2} \left[\frac{1}{f_u^2} + \frac{1}{f_d^2} + \frac{f_L - f_u}{f_u} \frac{2}{f_d^2} \right] \quad (16)$$

Note that $|f_L - f_u| \ll f_u$ and to this extent

$$\frac{1}{f_c^2} \approx \frac{1}{2} \left[\frac{1}{f_u^2} + \frac{1}{f_d^2} \right] \quad (17)$$

As above, the apparent carrier range change equation is the solution of equation 15 when $K = 0$:

$$R_c^* = \frac{c}{2f_u} (f_B t - M_c)$$

when $K \neq 0$, using equation 15

$$R_c^* = R - \frac{K}{f_c^2} \quad (\text{observe the minus sign and compare with equation 12}) \quad (18)$$

Equation 18 is solved to provide the corrected carrier range change measurement.

$$\boxed{R = R_c^* + \frac{K}{f_c^2}} \quad (19)$$

In principle the corrected range rate measurement is just the rate of change of the corrected carrier range change measurement given by equation 19.

$$\dot{R} = \dot{R}_c^* + \frac{\dot{K}}{2f_c} \quad (20)$$

The actual procedure of range rate extraction is somewhat more complicated, as described by Zillig, Reference 13. The biased doppler frequency, $(\dot{M}_c = f_b + f_d$ in Zillig's notation, Reference 13) is counted for a preset number, N , of cycles. The resulting count period is used to gate the count of a reference or clock frequency, f_r . The resulting clock count, C_o , is the basic measurement recorded.

$$C_o = \frac{Nf_r}{f_b + f_d^*} = \frac{Nf_r}{\dot{M}_c} \quad (21)$$

where $f_d^* = \frac{Nf_r - C_o f_b}{C_o}$ is the inferred two-way doppler shift corresponding to transmitted frequency, f_u , and includes ionospheric error.

f_b = bias frequency

then, from equation 15

$$f_d^* = \dot{M}_c - f_b = -\frac{2f_u}{c} \left(\dot{R} - \frac{\dot{K}}{2f_c} \right) \quad (22)$$

This is solved for \dot{R}_c^* by the operational equation resulting from setting $\dot{K} = 0$, so that for $\dot{K} \neq 0$ we have

$$\dot{R}_c^* = -\frac{c}{2f_u} f_d^* = \left(\dot{R} - \frac{\dot{K}}{2f_c} \right) \quad (23)$$

and the corrected range rate measurement is

$$\dot{R} = \dot{R}_c^* + \frac{\dot{K}}{2f_c} = -\frac{c}{2f_u} f_d^* + \frac{\dot{K}}{2f_c} = -\frac{c}{2f_u} \left(\frac{Nf_r - C_o f_b}{C_o} \right) + \frac{\dot{K}}{2f_c} \quad (24)$$

In the mechanization of the carrier phase measurement, it is not \dot{M}_c , as implied in equation 22, that is measured, but rather a carrier phase change is measured by counting a preset number, N , of Doppler plus bias, $f_b + f_d$, frequency cycles. The time, τ , to count these N cycles is determined by counting the number of cycles, C_o , of a higher reference frequency, f_r , occurring during the N -count.

Thus

$$\tau = t_2 - t_1 = \frac{C_o}{f_r} = \frac{N}{f_b + f_d^*} \quad (25)$$

and from equations 15 and 25,

$$\begin{aligned}
 N &= (f_b + f_d^*) \tau = M_c^* (t_2) - M_c^* (t_1) \\
 &= f_b \tau - \frac{2f_u}{C} \left[\left(R(t_2) - R(t_1) \right) - \frac{1}{f_c^2} \left(K(t_2) - K(t_1) \right) \right] \quad (26)
 \end{aligned}$$

As before, this is solved for the measured range change, $R_c^* (t_2) - R_c^* (t_1)$, by setting $K = 0$ in equation 26,

$$\begin{aligned}
 R_c^* (t_2) - R_c^* (t_1) &= \frac{C}{2f_u} \left(f_b \tau - N \right) = - \frac{C}{2f_u} \left(f_d^* \tau \right) \\
 &= \frac{C}{2f_u} \left[f_b \tau - \left(M_c^* (t_2) - M_c^* (t_1) \right) \right] \quad (27)
 \end{aligned}$$

Again the asterisked notation is used to denote inferred quantities which include ionospheric error. Then, for $K \neq 0$, using equations 15 and 27,

$$R_c^* (t_2) - R_c^* (t_1) = R(t_2) - R(t_1) - \frac{K(t_2) - K(t_1)}{f_c^2} \quad (28)$$

Equation 28 is solved to produce the corrected carrier range change.

$$R(t_2) - R(t_1) = R_c^* (t_2) - R_c^* (t_1) + \frac{K(t_2) - K(t_1)}{f_c^2} \quad (29)$$

or in terms of measured quantities,

$$R(t_2) - R(t_1) = \frac{C}{2f_u} \left(f_b \tau - N \right) + \frac{K(t_2) - K(t_1)}{f_c^2} \quad (30)$$

If an expression for range rate rather than range change is desired, it is given approximately by dividing the finite range change in equations 29 or 30 by the counting interval τ .

$$\begin{aligned} \dot{R} &\approx \frac{R(t_2) - R(t_1)}{\tau} = \frac{R_c^*(t_2) - R_c^*(t_1)}{\tau} + \frac{K(t_2) - K(t_1)}{f_c^2 \tau} \\ &= \frac{C}{2f_u} \left(f_b - \frac{N}{\tau} \right) + \frac{K(t_2) - K(t_1)}{f_c^2 \tau} \end{aligned} \quad (31)$$

This is the operational mechanization of equations 20 or 24, recognizing that

$$\dot{R}_c^* \approx \frac{R_c^*(t_2) - R_c^*(t_1)}{\tau}$$

and

$$\dot{K} \approx \frac{K(t_2) - K(t_1)}{\tau}$$

If there is significant acceleration during the counting interval, so that R changes during τ and the measured average Doppler frequency $f_d^* = -\frac{N}{\tau}$ is in general different than the instantaneous Doppler within that interval, then a correction term is needed.

5. RELATION TO PRIOR FORMULATION FOR EQUIVALENT FREQUENCY

The equivalent frequency formulation that had been in use for operational processing of GRARR (Reference 4) carrier data is equivalent to defining f_c (old) by equation 12 with the positive sign, i.e.

$$R_c^* \text{ (old)} = R + \frac{K}{f_c^2 \text{ (old)}} \quad (32)$$

where f_c was defined by

$$\frac{1}{f_c^2 \text{ (old)}} = \frac{1}{2} \left[\frac{1}{f_d^2} - \frac{1}{f_u^2} \right] \quad (33)$$

The accuracy of the old formulation was questioned when, due to a change in f_d and f_u , equation 33 started to produce imaginary values for f_c (old). However, by comparison with equation 18, it is not the minus sign of $1/f_u^2$ in equation 33 that is in error but the plus sign of $1/f_d^2$. In fact, f_c (old) should be imaginary if it is defined and used as in equation 32.

6. OTHER TRANSPONDER-RECEIVER SYSTEM CONFIGURATIONS

It is important to note that the results given by equations 15 and 18 for the carrier correction are very much a function of the configuration of the transponder-receiver system. It happens to be the same (in terms of f_u and f_d) for all four of the configurations considered here, all of which are basically similar. However, it is understood that alternative configurations are under consideration, and a different correction may be required for them.

7. SIMULTANEOUS USE OF CARRIER AND MODULATION MEASUREMENTS TO INFER IONOSPHERIC CORRECTION.

Due to the dispersive nature of the propagation in the ionosphere (but not in the troposphere) it is possible to utilize measurements on two or more frequencies in such a way as to eliminate the systematic ionospheric error as in the TRANET Doppler system. As an extension of the same principle, it is natural in a system such as GRARR to consider the simultaneous use of carrier and modulation measurements to achieve the same result.

From equations 12 and 18, if we compare R_m^* and R_c^*

$$R_m^* - R_c^* = KG \quad (34)$$

where

$$G = (1/f_c^2 + 1/f_m^2)$$

$$\frac{1}{f_m^2} = \frac{1}{2} \left[\frac{1}{f_u^2} + \frac{1}{f_d^2} \right]$$

$$\frac{1}{f_c^2} = \frac{1}{2} \left[\frac{1}{f_u^2} + \frac{1}{f_d^2} + \frac{f_L - f_u}{f_u} \frac{2}{f_d^2} \right]$$

Since G is known, we can use this relation to infer K, the ionospheric constant through the operational equation

$$\boxed{K^* = (R_m^* - R_c^*)/G} \quad (35)$$

However, two practical problems arise: that of carrier phase ambiguity and that of random errors. In actuality, while the modulation measurement is absolute the carrier measurement is only relative, i. e., subject to an unknown additive constant. In addition both have random errors that must now be considered. In other words, actually

$$R_m^* = R + \frac{K}{f_m^2} + \epsilon_m \quad (36)$$

$$R_c^* = R - \frac{K}{f_c^2} + C + \epsilon_c \quad (37)$$

where

C is a so far unknown additive constant

ϵ_m , ϵ_c are the random errors having standard deviations σ_m , σ_c .

Then solving for K* from equation 35

$$K^* = K + (\epsilon_m - C - \epsilon_c)/G \quad (38)$$

subject to both random (ϵ_m and ϵ_c) and constant (C) errors.

Carrier Data Correction. For correcting the carrier data we may now take into account that K is used only in differentiated or rate form from which the constant C, drops out and is so of no interest. Denoting the approximate differentiating operator used in the data extraction and preprocessing procedures by D () and the result of that operator by the dot notation, i. e., $D(X) \equiv \dot{X}$

then from equation 18

$$\dot{R}_c(\text{corr}) = D \left(R_c^* + \frac{K^*}{f_c^2} \right) = \dot{R}_c^* + \frac{\dot{K}^*}{f_c^2} \quad (39)$$

and using equation 35

$$\dot{R}_c(\text{corr}) = \frac{\dot{R}_m^*}{f_c^2 G} + \dot{R}_c^* \frac{(f_c^2 G - 1)}{f_c^2 G} \quad (40)$$

showing the relative weighting factors for the modulation and carrier measurements.

or applying equations (37) and (38) to equation (39)

$$\dot{R}_c(\text{corr}) = \dot{R} + \frac{\dot{\epsilon}_m + (f_c^2 G - 1)\dot{\epsilon}_c}{f_c^2 G} \quad (41)$$

But since to a very good approximation $f_c \approx f_m$ and since there is no particular physical reason to expect $\dot{\epsilon}_m$ and $\dot{\epsilon}_c$ to be correlated, we have

$$f_c^2 G \approx 2$$

and

$$\dot{R}_c(\text{corr}) \approx \frac{\dot{R}_m^* + \dot{R}_c^*}{2} \quad (42)$$

$$\approx \dot{R} + \frac{\dot{\epsilon}_m + \dot{\epsilon}_c}{2} \quad (43)$$

Correspondingly, the rms error is

$$\sigma_{\dot{R}}(\text{corr}) = \frac{1}{2} \sqrt{\sigma_m^2 + \sigma_c^2} \quad (44)$$

The problem inherent in this is that the random error, σ_m^* , is normally very much larger than σ_c^* , typically by something approaching the ratio of carrier frequency to modulation frequency or bandwidth. In effect, the corrected carrier range now has almost (1/2) the error of the modulation measurement, typically two to three orders of magnitude worse than the pure carrier measurement. For example, in the case of GRARR, typical observed short term noise errors are $\sigma_m \approx 3$ meters and $\sigma_c \approx .01$ meters/sec (Reference 12). If, for example, the data were differentiated by simple differencing over a one second span, then $\sigma_m^* \approx 3\sqrt{2} = 4.24$ meters/sec.

This random error degradation can be ameliorated to some extent by heavy smoothing on K^* as given by equation 35 prior to using it for correction. Clearly K^* is subject to much heavier smoothing than R^* , but the actual improvement available would be very much dependent on the actual dynamics of R and K in each particular case. If horizontal gradients of ionization level can be ignored, then the constraint afforded by the knowledge of the variation of K^* with elevation angle could be used to

make possible much heavier smoothing, by, in effect, smoothing the vertical column integrated refractivity rather than K^* which is along the varying slant path.

Modulation Data Correction. Since it contains an unknown, arbitrarily large constant, the estimated ionospheric parameter K^* (equation 38) is of no use for modulation data correction unless that constant can somehow be estimated. This may be feasible assuming the variation of K^* with elevation angle to be of known form, then curve fitting over the data span yields an estimate of the constant. The full error analysis of this regression technique is beyond the scope of this study but will be treated in a companion report in this series covering the recovery of ionospheric error estimates from dual frequency TRANET Doppler data.

Table 1
S-Band System Equations
 (Phase in Mc and Frequency in MHz, See Figure 1)

Equation No.	Carrier	Modulation	Modulation On Modulation
1	$f_u t$	$f_s t$	—
2	$f_u(t - P_u)$	$f_s(t - G_u)$	—
3	$(Mf_o - f_u)t + f_u P_u$	$f_s(t - G_u)$	—
4	$Nf_o t (= f_d t)$	$(Mf_o - f_u)t + f_u P_u$	$f_s(t - G_u)$
5	$Nf_o(t - P_d)$	$(Mf_o - f_u)(t - G_d) + f_u P_u$	$f_s(t - G_u - G_d)$
6	$(Nf_o - 60)t - Nf_o P_d$	—	—
7	$60t$	$(Mf_o - f_u)(t - G_d) + f_u P_u$	$f_s(t - G_u - G_d)$
8	$(f_o - \frac{60}{N})t - f_o P_d$	—	—
9	$(Mf_o - f_u)(t - G_d) + f_u P_u$	$f_s(t - G_u - G_d)$	—
10	$(Mf_o - f_u + 10)t - Mf_o G_d + f_u(P_u + G_d)$	—	—
11	$f_s(t - G_u - G_d)$	—	—
12*	$f_s(G_u + G_d)$	—	—
13	$(-f_u + Mf_o - \frac{M}{N} 60 + 90.5)t - Mf_o P_d$	—	—
14**	$f_B t + f_L(G_d - P_d) - f_u(P_u + G_d)$ where $M = 80, N = 60$ (Reference 1) $f_B = 80.5 - \frac{M}{N} 60 = 500 \text{ kHz}$ $f_L = Mf_o = 80 f_o$	—	—

*Modulation measurement
 **Carrier measurement

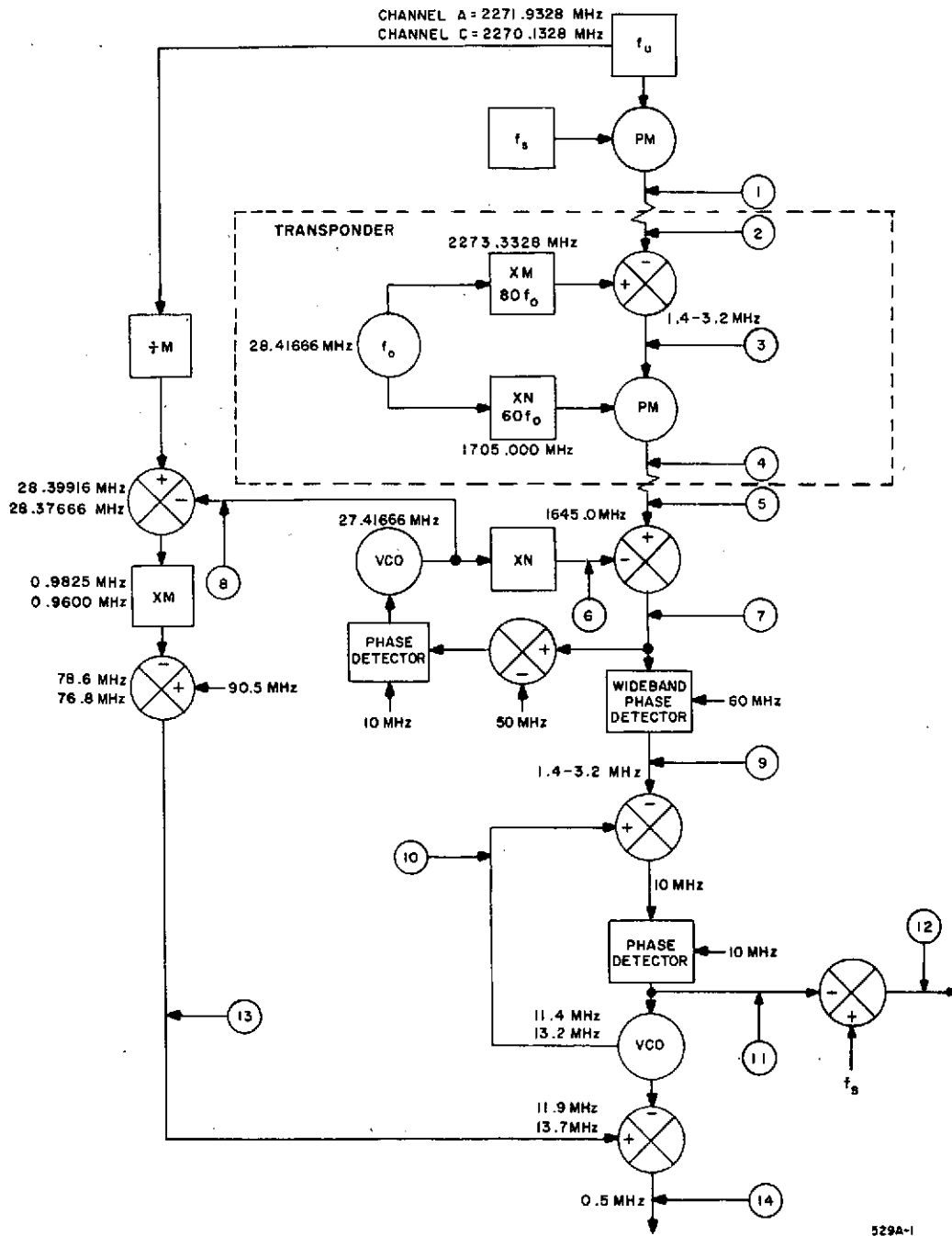
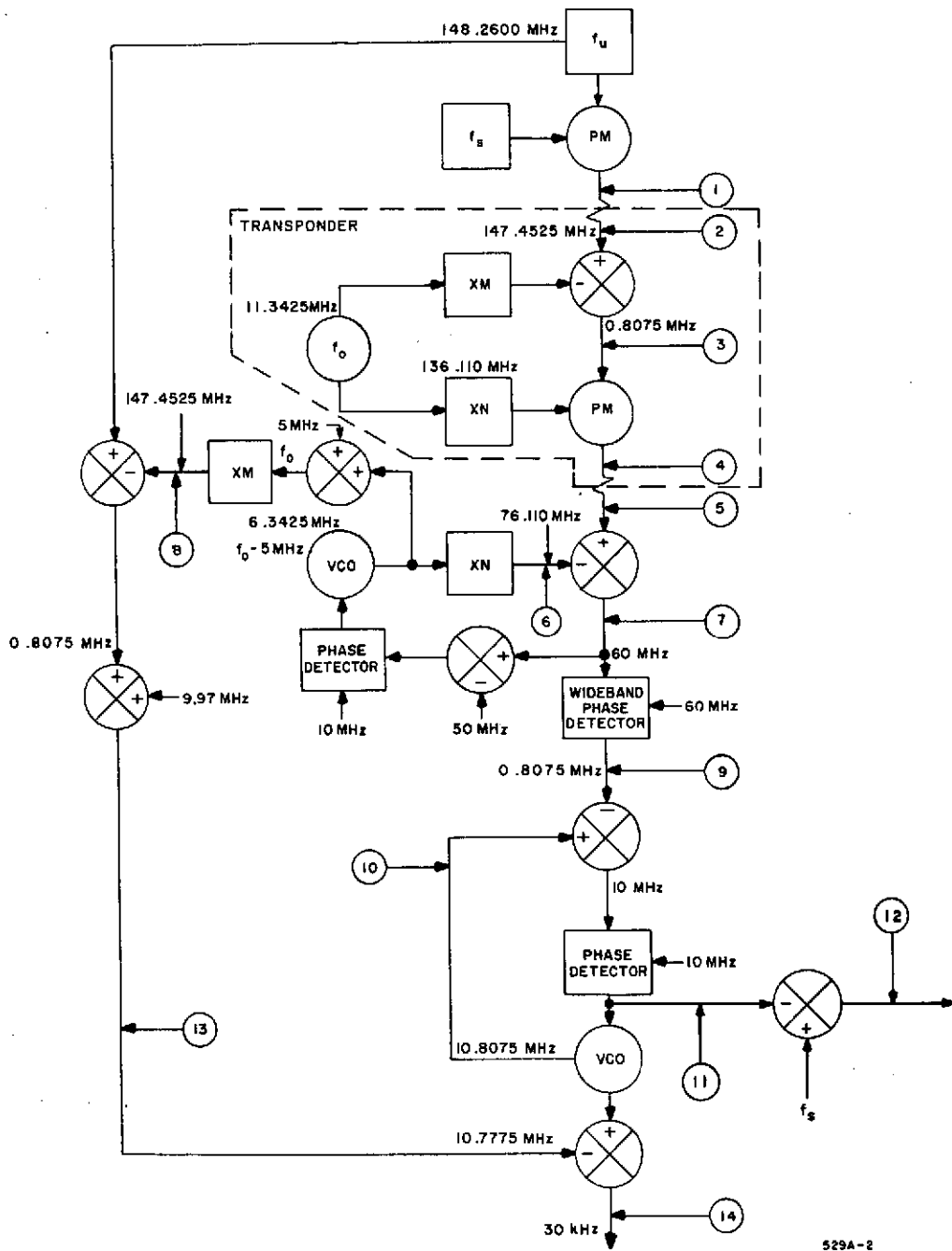

Figure 1. S-Band System, Simplified Diagram

Table 2
VHF System Equations
(Phase in Mc and Frequency in MHz, See Figure 2)

Equation No.	Carrier	Modulation	Modulation On Modulation
1	$f_u t$	$f_s t$	—
2	$f_u (t - P_u)$	$f_s (t - G_u)$	—
3	$f_u (t - P_u) - Mf_o t$	$f_s (t - G_u)$	—
4	$Nf_o t (= f_d t)$	$f_u (t - P_u) - Mf_o t$	$f_s (t - G_u)$
5	$Nf_o (t - P_d)$	$(f_u - Mf_o)(t - G_d) - f_u P_u$	$f_s (t - G_u - G_d)$
6	$(Nf_o - 60)t - Nf_o P_d$	—	—
7	$60t$	$(f_u - Mf_o)(t - G_d) - f_u P_u$	$f_s (t - G_u - G_d)$
8	$(Mf_o - \frac{M}{N} 60 + M5)t - Mf_o P_d$	—	—
9	$(f_u - Mf_o)(t - G_d) - f_u P_u$	$f_s (t - G_u - G_d)$	—
10	$(f_u - Mf_o + 10)t + Mf_o G_d - f_u (P_u + G_d)$	—	—
11	$f_s (t - G_u - G_d)$	—	—
12*	$f_s (G_u + G_d)$	—	—
13	$(f_u - Mf_o + \frac{M}{N} 60 - M5 + 9.97)t + Mf_o P_d$	—	—
14**	$f_B t + f_L (G_d - P_d) - f_u (P_u + G_d)$ where $M = 13, N = 12, (Reference\ 1)$ $f_B = 10 - \frac{M}{N} 60 + M5 - 9.97 = 30\ kHz$ $f_L = Mf_o = 13f_o$	—	—

*Modulation measurement
** Carrier measurement



529A-2

Figure 2. VHF System, Simplified Diagram

Table 3
Modified S-Band System Equations
 (Phase in Mc and Frequency in MHz, See Figure 3)

Equation No.	Carrier	Modulation	Modulation On Modulation
1	$f_u t$	$f_s t$	—
2	$f_u (t - P_u)$	$f_s (t - G_u)$	—
A	$(48f_o - f_u)t + f_u P_u$	$f_s (t - G_u)$	—
3	$60f_o t$	$(48f_o - f_u)t + f_u P_u$	$f_s (t - G_u)$
4	$60f_o (t - P_d)$	$(48f_o - f_u)(t - G_d) + f_u P_u$	$f_s (t - G_u - G_d)$
5	$(60f_o - 1800)t - 60f_o P_d$	$(48f_o - f_u)(t - G_d) + f_u P_u$	$f_s (t - G_u - G_d)$
6	$110t$	$(48f_o - f_u)(t - G_d) + f_u P_u$	$f_s (t - G_u - G_d)$
7	$(48f_o - f_u)(t - G_d) + f_u P_u$	$f_s (t - G_u - G_d)$	—
8	$10t$	$f_s (t - G_u - G_d)$	—
9	$f_s (t - G_u - G_d)$	—	—
10*	$f_s (G_u + G_d)$	—	—
11	$(48f_o - f_u + 10)t - 48f_o G_d + f_u (P_u + G_d)$	—	—
12	$(-30f_o + 1205)t + 30f_o P_d$	—	—
13	$(f_o - 28.1666\dots)t - f_o P_d$	—	—
14	$(\frac{f_u}{48} - 27)t$	—	—
15	$(-f_u + 48f_o)t - 48f_o P_d$	—	—
16	$10t - 48f_o (G_d - P_d) + f_u (P_u + G_d)$	—	—
17	$(\frac{f_u}{3600} + 10)t$	—	—
18**	$\frac{f_u}{3600} t + 48f_o (G_d - P_d) - f_u (P_u + G_d)$ $= f_B t + f_L (G_d - P_d) - f_u (P_u + G_d)$ where $f_B = \frac{f_u}{3600} \approx 500 \text{ kHz}$, $f_L = 48f_o$	—	—

*Modulation measurement
 **Carrier measurement

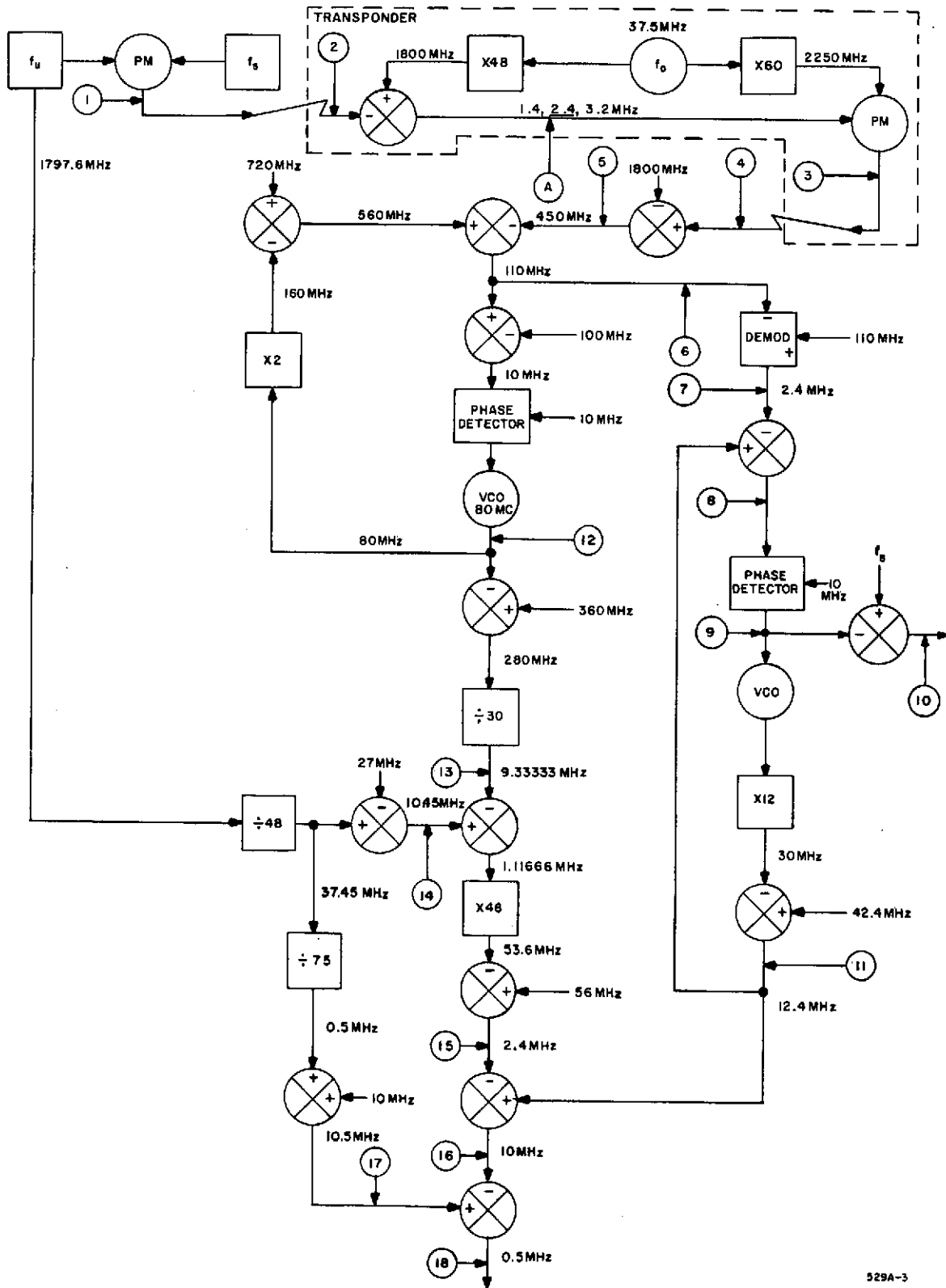

Figure 3. Modified S-Band System, Simplified Diagram

529A-3

Table 4
Modified VHF System Equations
(Phase in Mc and Frequency in MHz, See Figure 4)

Equation No.	Carrier	Modulation	Modulation On Modulation
1	$f_u t$	$f_s t$	—
2	$f_u(t - P_u)$	$f_s(t - G_u)$	—
A	$(f_u - 13f_o)t - f_u P_u$	$f_s(t - G_u)$	—
3	$12f_o t$	$(f_u - 13f_o)t - f_u P_u$	$f_s(t - G_u)$
4	$12f_o(t - P_d)$	$(f_u - 13f_o)(t - G_d) - f_u P_u$	$f_s(t - G_u - G_d)$
5	$(12f_o + 315)t - 12f_o P_d$	$(f_u - 13f_o)(t - G_d) - f_u P_u$	$f_s(t - G_u - G_d)$
6	$110t$	$(f_u - 13f_o)(t - G_d) - f_u P_u$	$f_s(t - G_u - G_d)$
7	$(f_u - 13f_o)(t - G_d) - f_u P_u$	$f_s(t - G_u - G_d)$	—
8	$10t$	$f_s(t - G_u - G_d)$	—
9	$f_s(t - G_u - G_d)$	—	—
10*	$f_s(G_u + G_d)$	—	—
11	$(f_u - 13f_o + 10)t + 13f_o G_d - f_u(P_u + G_d)$	—	—
12	$(-6f_o + 147.5)t + 6f_o P_d$	—	—
13	$13f_o t - 13f_o P_d$	—	—
14	$f_u t$	—	—
15	$(f_u - 13f_o)t + 13f_o P_d$	—	—
16	$10t + 13f_o(G_d - P_d) - f_u(P_u + G_d)$	—	—
17	$(10 - \frac{f_u}{5000})t$	—	—
18**	$\frac{f_u}{5000}t + 13f_o(G_d - P_d) - f_u(P_u + G_d)$ $= f_B t + f_L(G_d - P_d) - f_u(P_u + G_d)$ where $f_B = \frac{f_u}{5000} = 30 \text{ kHz}$, $f_L = 13f_o$	—	—

*Modulation measurement

**Carrier measurement

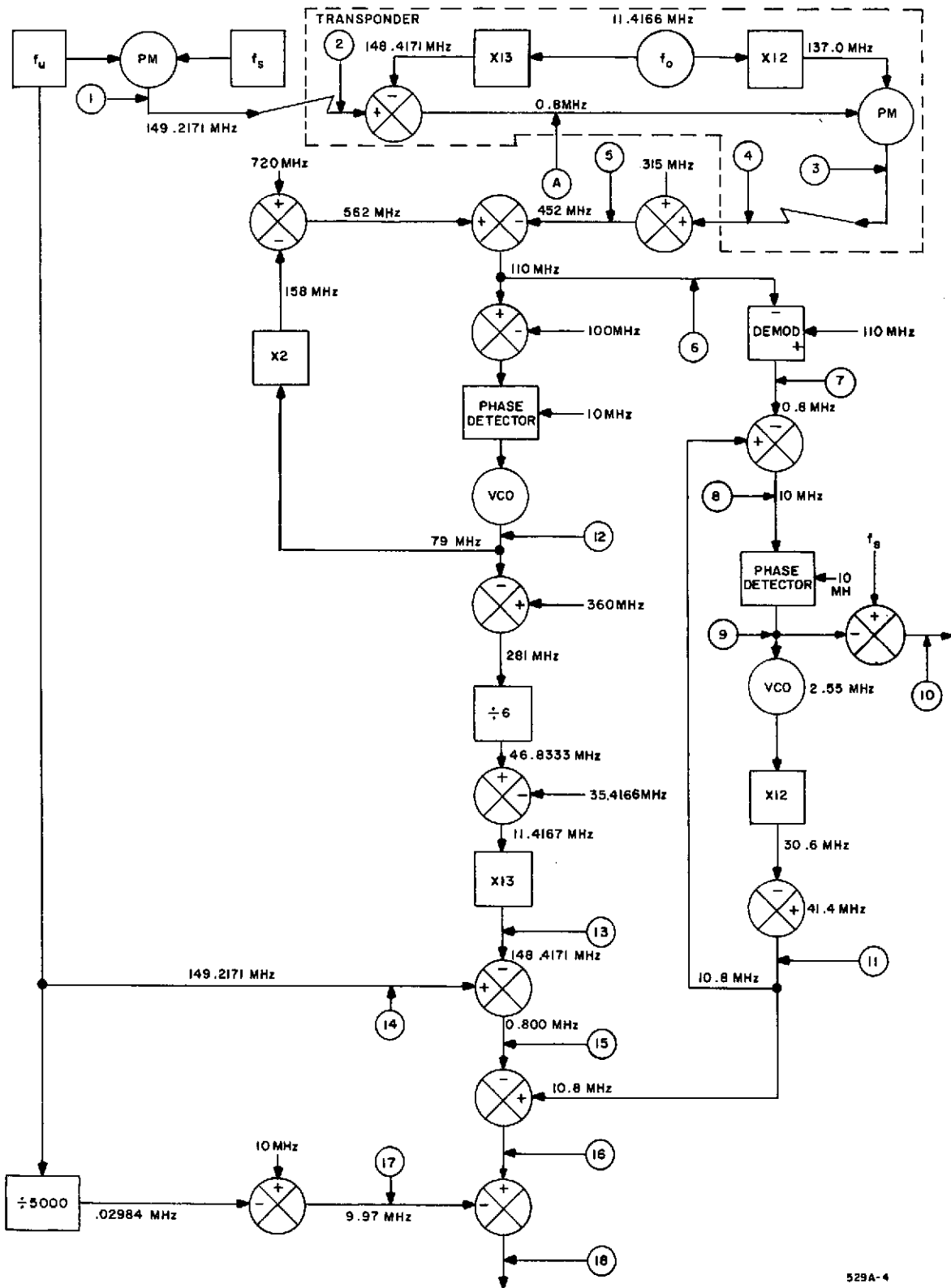

Figure 4. Modified VHF System, Simplified Diagram

REFERENCES

1. "Design Evaluation Report for Goddard Range and Range Rate System (GRR-2)", Contract NAS5-9731, General Electric Company, Figures 2.1.11 and 2.1.12. November 1964.
2. Design Evaluation Report for Goddard Range and Range Rate System, Contract NAS-10555, General Dynamics Company, Figures 3-83 and 3-84, Report No. R-67-042, December 13, 1967.
3. "Goddard Range and Range Rate System Design Evaluation Report", Contract NAS5-1926, Motorola Inc., Figures 4-14 and 4-17, Report No. W 2719-2-1, Revision 1, 23 November 1962.
4. Berbert, J.H., Maresca, P., Norris, P., and Reich, R., "Intercomparison of Collocated Laser Optical and GRARR Radio Ranging System Tracks on GEOS-A," GSFC X-514-67-447. September 1967.
5. A.J. Mallinckrodt, "Group and Phase Phenomena in an Inhomogeneous Ionosphere," Communications Research Laboratories, CRL No. 567. December 11, 1970. Also NASA GSFC X-552-71-171. March 1972.
6. Davies, K., "Ionospheric Radio Propagation," NBS Monograph #80, U.S. Government Printing Office. April 1965.
7. Mallinckrodt, A.J., "Ionospheric Errors in GRARR." CRL #548. May 18, 1969.
8. Mallinckrodt, A.J., "Ionospheric Errors in GRARR Rate System — Group Treatment," CRL No. 549. August 4, 1969.
9. Parker, H.C., "Trip Report on visit to A.J. Mallinckrodt, Los Angeles, California. November 6-7, 1969." Memorandum to J.A. Halk. November 13, 1969.
10. Parker, H.C., "GRARR Ionospheric Errors." Memorandum to J.H. Berbert. November 28, 1969.
11. Mallinckrodt, A.J., "Analysis of Ionospheric Refraction Corrections for GRARR Systems," Communications Research Labs, CRL #572. February 22, 1971.
12. Berbert, J. H., Hlavin, J. M., "Carnarvon Laser Collocation Experiment (CALACO)," NASA GSFC X-550-72-453. December 1972.
13. Zillig, D. J. "Data Formats of the Goddard Range and Range Rate System and the Application Technological Satellite Range and Range Rate System" NASA GSFC X-571-69-149, April 1969.