

2/11/74

**A STABILITY ANALYSIS OF CYLINDRICAL PANELS  
USING A FINITE ELEMENT FORMULATION**

(NASA-TM-X-69998) A STABILITY ANALYSIS  
OF CYLINDRICAL PANELS USING A FINITE  
ELEMENT FORMULATION Ph.D. Thesis - Va.  
Polytechnic Inst. and State Univ. (NASA)  
135 p HC \$9.75  
CSCL 20K

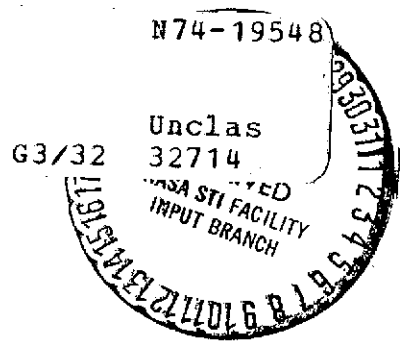

by

**Richard E. Snyder**

Thesis submitted to the Graduate Faculty of the  
**Virginia Polytechnic Institute**  
and  
**State University**  
in candidacy for the degree of

**DOCTOR OF PHILOSOPHY**

in

**Aerospace Engineering**

---

**May 1971**

A STABILITY ANALYSIS OF CYLINDRICAL PANELS  
USING A FINITE ELEMENT FORMULATION

by

Richard E. Snyder

Thesis submitted to the Graduate Faculty of the

Virginia Polytechnic Institute  
and  
State University

in partial fulfillment of the degree of

DOCTOR OF PHILOSOPHY

in

Aerospace Engineering

APPROVED:

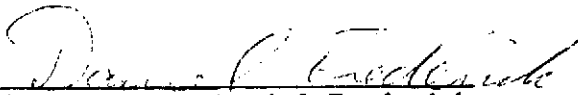
  
Chairman, Dr. Daniel Frederick

---

Dr. J. Schetz

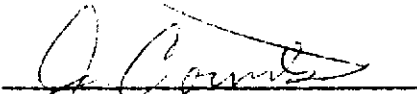
  
Dr. J. Counts

  
Dr. R. E. Fulton

  
Asst. Prof. W. D. Smith

May 1971

Blacksburg, Virginia

i

A STABILITY ANALYSIS OF CYLINDRICAL PANELS  
USING A FINITE ELEMENT FORMULATION

by

Richard E. Snyder

ABSTRACT

A cylindrical finite element suitable for the linear stability analysis of cylindrical shells is developed. Energy principles and variational methods lead to a problem formulation which lends itself to physical interpretations of the governing matrices of the finite element. By properly grouping the terms which result from taking the second variation of the potential energy of the element, it is possible to identify three distinct types of matrices. The first matrix is the conventional stiffness matrix; the second is an "initial stress" stiffness matrix; and the third is an "initial displacement" stiffness matrix. With the assumption of linearity, the buckling problem is stated in terms of the classical linear real eigenvalue equation. This problem formulation was programmed on the CDC 6600 series computer. The computer program is used to analyze the buckling of a variety of structures. Columns, arches, flat plates and curved panels with and without cutouts are considered. Comparisons are made between closed form solutions and the results of the present analysis to establish confidence in the techniques used. Curved panels with cutouts of varying size are analyzed for buckling. The influence of curvature and cutout size on the prebuckling deformations in a curved panel are studied and found to be significant. The prebuckling deformations are shown to have a significant influence on the buckling strength of curved panels with cutouts.

TABLE OF CONTENTS

CHAPTER	TITLE	PAGE
	TITLE	i
	TABLE OF CONTENTS	ii
	LIST OF TABLES AND FIGURES	iv
	LIST OF SYMBOLS	vi
I.	INTRODUCTION	1
II.	APPLICATION OF ENERGY PRINCIPLES AND VARIATIONAL METHODS TO LINEAR STABILITY ANALYSIS	4
	II-1 Basic Principles	4
	II-2 The Beam-Column	5
III.	THE CYLINDRICAL, THIN SHELL, FINITE ELEMENT	13
	III-1 Basic Assumptions	13
	III-2 Formulation of the Potential Energy	14
	III-3 Second Variation of the Potential Energy	19
	III-4 The Stiffness Matrix	22
	III-5 The Initial Stress and Initial Displacement Stiffness Matrices	34
IV.	METHOD OF COMPUTATION	48
V.	APPLICATIONS OF THE COMPUTER PROGRAM	54
VI.	CONCLUDING REMARKS	77
VII.	REFERENCES	80
VIII.	ACKNOWLEDGMENTS	84
IX.	VITA	85

TABLE OF CONTENTS

CHAPTER		PAGE
X.	APPENDIX A - The Development of the Conventional, the Initial Stress and the Initial Displacement Stiffness Matrices for the Beam-Column and Arch Elements.	86
	X-1 The Beam-Column	86
	X-2 The Arch	90
XI.	APPENDIX B - Principal Matrices in the Development of the Initial Stress and Initial Deformation Matrices for the Cylindrical Element.	94
XII.	APPENDIX C - Computer Program Listing	109

LIST OF TABLES AND FIGURES

TABLE		PAGE
III-1	Arrangement of Terms in the Stiffness Matrices for the Cylindrical Element	25a
III-2	Elements of $[K_e^0]$ for the Cylindrical Element	26
III-3	Elements of $[K_e^1]$ for the Cylindrical Element	39
III-4	Elements of $[K_e^2]$ for the Cylindrical Element	41
V-1	Buckling Coefficient for Curved Panels	60
B-1	Elements of $[G]^T [K^1] [G]$	97
B-2	Elements of $[G]^T [K^2] [G]$	100
 FIGURE		
II-1	The Beam-Column	7
III-1	Geometry and Displacements of the Doubly Curved Shell Element	15
	a. Geometry	
	b. Linear Displacements	
III-2	Internal Stresses	18
	a. Stress Components	
	b. Stress Resultants	
	c. Bending Moments	
III-3	Geometry of the Cylindrical Element and Associated Displacements	23
	a. Element Geometry	
	b. Linear Displacements	
	c. Angular Displacements	

FIGURE		PAGE
IV-1	Elastic Stability Program Flow Chart	53
V-1	Euler Column Buckling vs. Element Size	55
V-2	Buckling of a Simply Supported Flat Plate vs. Grid Size	57
V-3	Simply Supported Arch with a Uniform Load	59
V-4	Buckling of Simply Supported Curved Panels vs. Grid Size	62
V-5	Geometry of the Curved Panel with a Cutout	63
V-6	Stress Distribution Along $x = 0$ Due to an Uniform Axial Load of $-1.0$ lb/in.	64
V-7	Normal Deflection Along $x = 0$ Due to an Uniform Axial Load of $-1.0$ lb/in.	66
V-8	Normal Deflection Along $x = 0$ Due to an Uniform Axial Load of $-1.0$ lb/in.	67
V-9	Normal Deflection Along $x = 0$ Due to an Uniform Axial Load of $-1.0$ lb/in.	68
V-10	Buckling of a Flat Plate With Varying Cutout Size	70
V-11	Buckling of a Curved Panel ( $Z = 1$ ) With Varying Cutout Size	71
V-12	Buckling of a Curved Panel ( $Z = 5$ ) With Varying Cutout Size	72
V-13	Buckling of a Curved Panel ( $Z = 10$ ) With Varying Cutout Size	73
V-14	Buckling of Curved Panels With Varying Curvature and Cutout Size	74
A-1	Arch Element	91

LIST OF SYMBOLS

- A cross sectional area of beam-column or arch, panel length  
in Axial direction
- [A] matrix of geometrical parameters (equation III-20, A-2, B-2)
- a,b element dimensions (Figure II-1a and III-3a)
- B panel dimension in circumferential direction
- [B] matrix of displacement function terms (equation III-24, A-4,  
B-3)
- C curvature of a shell middle surface
- [D] matrix of differential operators (equations III-20, A-3, B-2)
- $D_b$  flexural rigidity,  $\frac{Eh^3}{12(1-\nu^2)}$
- $D_m$  membrane rigidity,  $Eh/(1-\nu^2)$
- E modulus of elasticity
- [E] initial displacement matrix before integrating (Table B-1)
- $e_{i,j}$  one term in the [E] matrix
- e nonlinear strain (equations II-4 and III-2)
- G shear modulus
- [G] matrix of coefficients relating strain to displacements  
(equations II-20, A-7, B-4)
- {g} displacement vector (equation VI-19, VII-20, III-24, A-4)
- [H] initial stress matrix prior to integrating (Table B-2)
- $h_{i,j}$  one term in the [H] matrix
- h shell thickness
- I area moment of inertia
- [K] stiffness matrix



$K_x$	buckling coefficient for panels, $\frac{B^2 N_{cr}}{\pi^2 D}$
$k_{i,j}$	one term of a stiffness matrix
$L$	length of a structure
$\ell$	length of a finite element
$M$	bending moment (equation II-9)
$M_1, M_2, M_{12}$	bending moments (figure III-2b and equation III-5c)
$N$	axial force (equation II-8)
$N_i, V_i, M_i$	axial force, shear force and bending moment applied at node $i$ (figures II-1 and A-1)
$N_1, N_2$	membrane stress resultants (figure II-2b and equation III-5)
$N_{12}$	in-plane shear stress resultant (figure III-2b and equation III-5)
$Q_1, Q_2$	transverse shear stress resultants (figure III-2 and equation III-5b)
$R$	radius of curvature
$[S]$	element stress matrix
$s$	distance
$U$	strain energy (equation III-6)
$u, v, w$	displacements in the $\xi_1, \xi_2$ and $\xi_3$ directions respectively (figure III-3b)
$X, \theta, Z$	coordinates for the cylindrical shell element (figure III-3)
$Z$	curvature parameter, $\frac{B^2}{Rh} \sqrt{1-\nu^2}$
$\alpha_1, \alpha_2$	Lamé parameters (equation III-1)
$\beta$	rotation (equation III-2)
$[F]$	matrix of coefficients (equation A-5)
$\{\Delta\}$	element corner displacement vector (equations III-2, A-5)

$\delta$	variational symbol
$\epsilon$	linear strain (equations II-5, III-2)
$\nu$	Poission's ratio
$\chi$	bending distortion (equation III-3)
$\xi_1, \xi_2, \xi_3$	middle surface coordinates for the doubly curved shell element (figure III-1)
$\pi$	total potential energy (equation II-3)
$\Delta\pi$	potential energy resulting from a virtual displacement (equation II-11)
$\phi$	rotation (equations II-6, figure III-3c)
$\lambda$	eigenvalue (equation II-23)
$\sigma$	stress (figure III-2a)
{ }	column vector
{ }	row vector
[ ]	rectangular matrix

## SUPERSCRIPTS

0,1,2	referencing the "conventional," the "initial stress" and "initial displacement" stiffness matrices respectively
T	transpose

## SUBSCRIPTS

1,2,3,4	refers to corners of the plate or cylindrical element
cr	refers to a buckling load or stress
e	refers to a finite element

A subscript preceded by a comma denotes partial differentiation with respect to the subscript.

Other symbols are defined in the text where they appear.

CHAPTER I.  
INTRODUCTION

Plate and shell stability analysis and its application to practical engineering structures has been the subject of extensive structural research efforts. Despite this, many problems still remain in the accurate prediction of the buckling mode of failure of many types of practical plate and shell configurations, particularly those with holes or cutouts. For example, reliable procedures for the analysis of a flat plate with a large cutout are limited. The finite element method provides a means of analyzing problems such as these. The development of this method has been prompted by its ability to model complex geometries and loading conditions. To date, major developments in finite element methods have concentrated on stress and vibration analysis with only limited attention given to stability. The objective of this dissertation is to report the results of an extension of the finite element method to problems of thin shell instability. The extension will concentrate on the development and use of elements which, thus far, have seen only limited application in finite element technology. Primary emphasis will be placed on the buckling analysis of curved panels with rectangular cutouts. However, the method will also be applied to columns, flat plates and arches.

The field of shell stability analysis is one of the most extensively investigated areas of classical mechanics. The list of references associated with classical shell stability is very formidable. References to classical shell buckling investigations are cited herein only to the extent that they relate to special aspects of the finite element approach.

Formalized finite element methods generally began with the presentation of the "direct stiffness" method by Turner, Clough, Martin, and Topp (ref. 1). Since then, finite elements have been used in the stress analysis of a wide variety of structures, including frames, arches, shells, and solids. In recent years, attention has been turned to the application of finite element technology to the stability of structures. Expansion of the stiffness method to handle nonlinear, large deflection problems was first presented in 1960 by Turner, Dill, Martin and Melosh (ref. 2). In 1962, Turner, et.al., (ref. 3) enlarged on the nonlinear finite element technique by presenting an eigenvalue procedure to determine the buckling of columns. Gallagher and Padlog (ref. 4) independently derived a stability coefficient matrix to predict column buckling. Summaries of the current state of the art of stability predictions using beam-column elements are contained in references 5, 6 and 7. In these references, the stability problem is framed in terms of the conventional stiffness matrix and what is termed the "geometrical" or "initial stress" stiffness matrix. The term "initial stress" stiffness matrix will be adopted in this work. The terminology applied to this new matrix reflects its dependence on the initial state of stress and undeformed geometry of the element.

In reference 8, Gallagher, et.al., extended finite element stability methods to flat triangular elements. The explicit formulation of the initial stress matrix for a rectangular plate in bending is presented by Kapur and Hartz in reference 9. The stability of doubly curved shells of revolution subjected to axisymmetric loading, using the finite element

method, was investigated by Navaratna, Pian and Witmer (ref. 10). The stability of cylindrical shells using curved finite elements was studied by Bogner, Fox and Schmit (ref. 11). In reference 11, the problem is formulated from the standpoint of direct minimization of the total potential energy as opposed to the development of identifiable stiffness and initial stress stiffness matrices. In addition, a large number of degrees of freedom (i.e., 48) are used for each element.

There is limited literature published on the buckling of curved cylindrical panels. Classical analyses of curved panels typically consider the case of an infinite aspect ratio (ref. 12 and 13). Gerard and Becker (ref. 14) directly consider "very wide" and "very narrow" curved panels and then fair a curve between those results to cover panels of intermediate dimensions. The importance of boundary conditions in the determination of the buckling of curved panels is established by Rehfield and Hallaur (ref. 15).

The effect of cutouts in cylinders has been the subject of several experimental investigations (ref. 16, 17 and 18). Brogan and Almroth (ref. 17) applied a finite difference approximation to the governing equations and obtained reasonable agreement with experiments. No references dealing with the bifurcation buckling of curved panels with cutouts were found, and indicates a need for data on such problems.

CHAPTER II.  
APPLICATION OF ENERGY PRINCIPLES AND  
VARIATIONAL METHODS TO LINEAR STABILITY ANALYSIS

II.-1 Basic Principles

The principle of minimum potential energy establishes that for equilibrium the total potential energy,  $\pi$ , for a system must be extremal or stationary (ref. 19 and 20). Thus for equilibrium, the first variation of the potential energy vanishes.

$$\delta\pi = 0 \quad (\text{II-1})$$

where  $\delta$  is the variational symbol.

The stability of the equilibrium state can be investigated by examining the second variation of the potential energy. An equilibrium state is stable if every neighboring state has a larger potential energy. In other words, an equilibrium state is stable if, in addition to satisfying equation II-1 it also satisfies the condition  $\delta^2\pi > 0$ . Conversely, equilibrium is unstable if  $\delta^2\pi < 0$ . Therefore, the infinitesimal stability limit as used herein corresponds to the case of

$$\delta^2\pi = 0 \quad (\text{II-2})$$

This principle is well-known for continuum problems and has been applied to approximations based on finite element methods in references 4, 5, 21, 22, 23 and 24. A formulation of the second variation of the potential energy that lends itself conveniently to the numerical approximations found in the finite element method will be presented. In this chapter, these concepts will be applied to a beam-column to illustrate the approach. In Chapter III, the same methods will be applied to the

more complex curved panel problem.

## II.-2 The Beam Column

The beam-column finite element shown in Figure II-1 extends between node points 1 and 2, and has a cross sectional area,  $A$ ; a length  $\ell$ ; a moment of inertia,  $I$ ; and a modulus of elasticity,  $E$ . The forces acting at each end of the beam-column are shown in their positive directions in Figure II-1. The displacement in the  $Z$  direction,  $w$ , and the displacement in the  $X$  direction,  $u$ , are also shown in their positive directions. The total potential energy of the finite element system is

$$\pi = \frac{1}{2} \int_0^{\ell} EAe^2 dX + \int_0^{\ell} \frac{EI}{Z^2} w_{,xx}^2 dX - N_1 u_1 - V_1 w_1 - M_1 \theta_1 - N_2 u_2 - V_2 w_2 - M_2 \theta_2 \quad (\text{II-3})$$

where (reference 19)

$$e = \epsilon + \frac{1}{2} \phi^2 \quad (\text{II-4})$$

and

$$\epsilon = u_{,x} \quad (\text{II-5})$$

$$\phi = w_{,x} \quad (\text{II-6})$$

Here,  $e$  is the nonlinear middle surface strain composed of the linear strain  $\epsilon$  and the rotation  $\phi$ . The first integral on the right hand side of equation II-3 is the membrane strain energy and the second integral is the bending strain energy. The remaining terms represent the potential energy of the external forces.

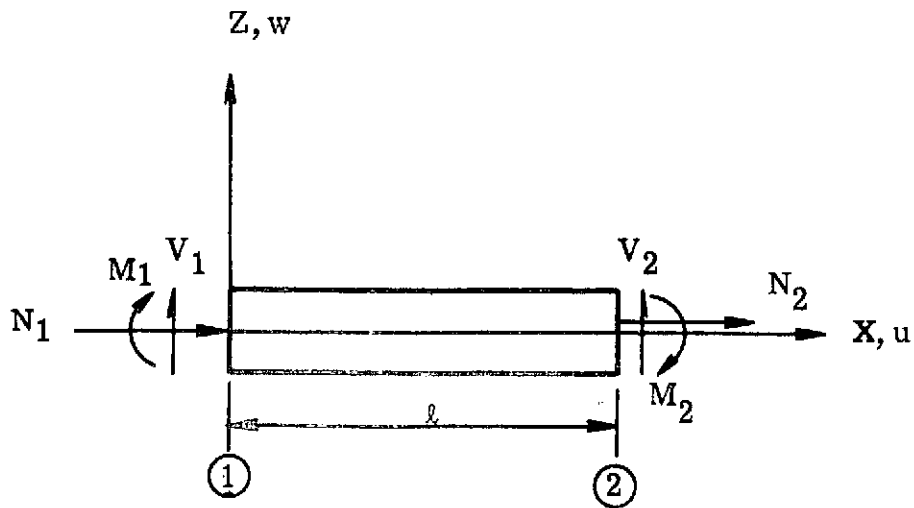

$E$  = Modulus of elasticity  
 $A$  = Area  
 $I$  = Area moment of inertia

Figure II-1. The Beam Column



Substituting equation II-4 into II-3 and rearranging leads to

$$\begin{aligned} \Pi = & \frac{1}{2} \int_0^L EA \epsilon^2 dX + \frac{1}{2} \int_0^L EA \phi^2 (\epsilon + \frac{1}{2} \phi^2) dX - \frac{1}{2} \int_0^L EA \frac{\phi^4}{4} dX + \frac{1}{2} \int_0^L EI w_{,xx}^2 dX \\ & - N_1 u_1 - V_1 w_1 - M_1 \theta_1 - N_2 u_2 - V_2 w_2 - M_2 \theta_2 \end{aligned} \quad (II-7)$$

The axial force and bending moment may be written as

$$N = AEe = AE \left( \epsilon + \frac{1}{2} \phi^2 \right) \quad (II-8)$$

$$M = EI w_{,xx} \quad (II-9)$$

Substituting II-8 and II-9 into II-7,

$$\begin{aligned} \pi = & \frac{1}{2} \int_0^L EA \epsilon^2 dX + \frac{1}{2} \int_0^L N \phi^2 dX - \frac{1}{2} \int_0^L EA \frac{\phi^4}{4} dX + \frac{1}{2} \int_0^L M w_{,xx} dX \\ & - N_1 u_1 - V_1 w_1 - M_1 \theta_1 - N_2 u_2 - V_2 w_2 - M_2 \theta_2 \end{aligned} \quad (II-10)$$

After giving the system a virtual displacement, the total potential energy becomes

$$\begin{aligned} \pi + \Delta\pi = & \frac{1}{2} \int_0^L EA (\epsilon + \delta\epsilon)^2 dX + \frac{1}{2} \int_0^L (N + \Delta N) (\phi + \delta\phi)^2 dX - \frac{1}{2} \int_0^L \frac{EA}{4} (\phi + \delta\phi)^4 dX \\ & + \frac{1}{2} \int_0^L (M + \Delta M) (w_{,xx} + \delta w_{,xx}) dX - N_1 u_1 - V_1 w_1 - M_1 \theta_1 - N_2 u_2 - V_2 w_2 \\ & - M_2 \theta_2 - N_1 \delta u_1 - V_1 \delta w_1 - M_1 \delta \theta_1 - N_2 \delta u_2 - V_2 \delta w_2 - M_2 \delta \theta_2 \end{aligned} \quad (II-11)$$

where

$$\Delta N = EA \left[ \delta\epsilon + \phi \delta\phi + \frac{\delta^2 \phi}{2} \right] \quad (II-12)$$

$$\Delta M = EI \delta w_{,xx} \quad (II-13)$$

Substituting II-12 and II-13 into II-11,

$$\begin{aligned}
\pi + \Delta\pi &= \frac{1}{2} \int_0^l EA(\epsilon^2 + 2\epsilon\delta\epsilon + \delta^2\epsilon) dX + \frac{1}{2} \int_0^l N(\phi^2 + \frac{1}{2} \phi\delta\phi + \delta^2\phi) dX \\
&+ \frac{1}{2} \int_0^l EA\left(\delta\epsilon + \phi\delta\phi + \frac{\delta^2\phi}{2}\right) (\phi^2 + 2\phi\delta\phi + \delta^2\phi) dX \\
&- \frac{1}{8} \int_0^l EA(\phi^4 + 4\phi^3\delta\phi + 6\phi^2\delta^2\phi + 4\phi\delta^3\phi + \delta^4\phi) dX \\
&+ \frac{1}{2} \int_0^l Mw_{,xx} dX + \frac{1}{2} \int_0^l M\delta w_{,xx} dX + \frac{1}{2} \int_0^l EIw_{,xx}\delta w_{,xx} dX \\
&+ \frac{1}{2} \int_0^l EI\delta^2 w_{,xx} dX - N_1 u_1 - V_1 w_1 - M_1 \theta_1 - N_2 u_2 - V_2 w_2 - M_2 \theta_2 \\
&- N_1 \delta u_1 - V_1 \delta w_1 - M_1 \delta \theta_1 - N_2 \delta u_2 - V_2 \delta w_2 - M_2 \delta \theta_2
\end{aligned} \tag{II-14}$$

$\pi + \Delta\pi$  may be expressed in the following form (ref. 19)

$$\pi + \Delta\pi = \pi + \delta\pi + \frac{1}{2!} \delta^2\pi + \dots \tag{II-15}$$

By arranging equation II-14 into the form of equation II-15, the matrix form of the second variation is

$$\delta^2\pi = \int_0^l [\delta\epsilon \quad \delta\phi \quad \delta w_{,xx}] \left[ EA \begin{bmatrix} 100 \\ 000 \\ 00\frac{I}{A} \end{bmatrix} + \begin{bmatrix} 000 \\ 0N0 \\ 000 \end{bmatrix} + EA \begin{bmatrix} 0\phi & 0 \\ \phi\phi^2 & 0 \\ 00 & 0 \end{bmatrix} \right] \begin{Bmatrix} \delta\epsilon \\ \delta\phi \\ \delta w_{,xx} \end{Bmatrix} dx \tag{II-16}$$

Equation II-16 may be stated more conveniently as

$$\delta^2\pi = \int_0^l \{\delta\bar{\epsilon}\}^T [\hat{K}^0] \{\delta\bar{\epsilon}\} dx + \int_0^L \{\delta\bar{\epsilon}\}^T [\hat{K}^1] \{\delta\bar{\epsilon}\} dx + \int_0^L \{\delta\bar{\epsilon}\}^T [\hat{K}^2] \{\delta\bar{\epsilon}\} dx \tag{II-17}$$

where

$$\{\delta\bar{\epsilon}\} = \begin{Bmatrix} \delta\epsilon \\ \delta\phi \\ \delta w_{,xx} \end{Bmatrix}$$

$$[\hat{K}^0] = EA \begin{bmatrix} 1 & 0 & 0 \\ 0 & 0 & 0 \\ 0 & 0 & \frac{I}{A} \end{bmatrix}, \quad [\hat{K}^1] = \begin{bmatrix} 0 & 0 & 0 \\ 0 & N & 0 \\ 0 & 0 & 0 \end{bmatrix}, \quad [\hat{K}^2] = EA \begin{bmatrix} 0 & \phi & 0 \\ \phi & \phi^2 & 0 \\ 0 & 0 & 0 \end{bmatrix}$$

Prior to introducing the numerical approximations involved in the finite element method, several general statements may be made concerning the use of equation II-17 for finite element type buckling analyses.

° Terms relating to the work of the external forces do not appear in the second variation of the potential energy.

°  $[\hat{K}^0]$  leads to the conventional stiffness matrix for a beam-column. (See reference 24 and Appendix A).

°  $[\hat{K}^1]$  is a function of the load in the element and leads to a matrix denoted herein as the "initial stress" stiffness matrix.

°  $[\hat{K}^2]$  is a function of rotational deformations and leads to a matrix denoted herein as the "initial displacement" stiffness matrix.

° The finite element numerical approximations (i.e., displacement function) need not necessarily be the same when dealing with  $[\hat{K}^0]$ ,  $[\hat{K}^1]$  and  $[\hat{K}^2]$ . However, if convergence is to be obtained in the limit, all of the numerical approximations must represent the essential character of the problem.

° A static solution to the problem must first be accomplished to establish values of  $N$  and  $\phi$  which are required for the evaluation of  $[\hat{K}^1]$  and  $[\hat{K}^2]$ .

The details of the steps required to develop the conventional, the initial stress and the initial displacement stiffness matrices for

both the beam-column and the arch are given in Appendix A. The matrix formulation of the strain-displacement relations and the assumed displacement function as well as intermediate matrix products are presented. The symbols used in Appendix A correspond to those used in this chapter.

For the beam-column, the strains are related to the displacements,  $u$  and  $w$ , through a matrix of differential operators.

$$\{\bar{\epsilon}\} = [D] \{g\} \quad (\text{II-18})$$

A critical feature of any finite element development is the displacement function chosen to represent the deformation characteristics of the element in terms of the nodal displacements. A linear variation of  $u$  and a cubic variation of  $w$ , as is used in Appendix A, is frequently assumed (ref. 5). Such a set of assumptions stated in matrix form is

$$\{g\} = [B] [\Gamma] \{\Delta\} \quad (\text{II-19})$$

The matrix  $[B]$  is a function of  $X$  and the  $[\Gamma]$  matrix is a function of the element geometry.  $\{\Delta\}$  is the vector of nodal displacements. Substituting equation II-19 into equation II-18,

$$\{\bar{\epsilon}\} = [G] \{\Delta\} \quad (\text{II-20})$$

where

$$[G] = [D] [B] [\Gamma]$$

Hence

$$\{\delta\bar{\epsilon}\} = [G] \{\delta\Delta\}$$

Equation II-17 may be written

$$\delta^2\pi = \{\delta\Delta\}^T \left[ [K^0_e] + [K^1_e] + [K^2_e] \right] \{\delta\Delta\} \quad (\text{II-21})$$

where

$$[K_e^0] = \int_0^L [G]^T [\hat{K}^0] [G] dx$$

$$[K_e^1] = \int_0^L [G]^T [\hat{K}^1] [G] dx$$

$$[K_e^2] = \int_0^L [G]^T [\hat{K}^2] [G] dx$$

In general,  $A$ ,  $E$  and  $I$ , are functions of the longitudinal coordinate,  $X$ . This is also true of the load,  $N$ , and the rotation,  $\phi$ . Before the integration of the terms in equation II-21 may be carried out, an assumption must be made regarding the variation of these parameters along the length of the beam-column. The assumption that  $A$ ,  $E$  and  $I$  are constants over the length of the element is commonly made. This assumption will be adopted here. Further,  $N$  and  $\phi$  will also be assumed to be constants over the length of the element. The matrices  $[K_e^0]$ ,  $[K_e^1]$  and  $[K_e^2]$  given in Appendix A are based on these assumptions.

Applying the neutral stability condition,  $\delta^2\pi = 0$ , the buckling criterion for the beam-column element is

$$\det \left[ [K_e^0] + [K_e^1] + [K_e^2] \right] = 0 \quad (\text{II-22})$$

The eigenvalue involved in the solution of equation II-22 is the ratio of the bifurcation load,  $N_{cr}$ , to the applied load,  $N$ . The load and rotation at buckling are equal to the initial load and rotation times the eigenvalue. Because of the  $\phi^2$  term in  $[K_e^2]$ , equation II-22 has the form of a quadratic eigenvalue problem.

The nonlinear strain displacement relations used in this development assume the square of the rotations to be of the same order as the strains, and the strain to be small compared to unity or  $\epsilon = 0(\phi^2) \ll 1$ . Thus, a reasonable first approximation to the solution of equation II-22 for many problems is to assume the  $\phi^2$  terms to be negligible compared to the  $\phi$  terms. With this approximation, equation II-22 becomes a linear eigenvalue problem and is

$$\det \left| [K^0_e] + \lambda \left[ [K^1_e] + [K^2_e] \right] \right| = 0 \quad (\text{II-23})$$

where

$$\begin{aligned} \lambda &= N_{cr}/N \\ N_{cr} &= \text{buckling load} \\ N &= \text{applied load} \end{aligned}$$

The method of assembling element stiffness, initial stress stiffness and initial displacement stiffness matrices to represent a complete structure will be discussed in Chapter III. The method used in the determination of the eigenvalues is described in Chapter IV.

## CHAPTER III.

THE CYLINDRICAL, THIN SHELL, FINITE ELEMENT

The following development is an extension of a stiffness formulation by Gallagher (ref. 25) for the doubly curved shell element, shown in Figure III-1, to include elastic instability effects. The Gallagher shell element was selected as a basis for this work because it has been shown to give reliable results and because it is well documented. An expression for the strain energy of the doubly curved shell element will first be derived. Then, prior to introducing an assumed displacement function, the problem will be specialized to a singly curved cylindrical element.

The cylindrical element has wide application in aerospace type structures. It can be used in the analysis of structures such as airplane fuselages, rocket motor cases, tanks, and interstage adaptors. Elliptical cross sections may be represented with cylindrical elements by allowing the radius of curvature to vary from element to element.

III.-1 Basic Assumptions

In this development the shell material is assumed to be isotropic and to obey Hooke's Law. The neutral surface of the shell lies midway through the thickness. Applying the Kirchhoff-Love hypothesis, it is further assumed that:

1. The displacements  $u$ , and  $v$  corresponding to the directions  $\xi_1$  and  $\xi_2$  (Figure III-1) respectively, are linear in the thickness direction,  $\xi_3$ .

2. All components of stress normal to the middle surface are negligible.
3. The displacement normal to the middle surface is a function only of the middle surface coordinates.

### III.-2 Formulation of the Potential Energy

As was illustrated in Chapter II, the potential energy of the external forces applied to an element does not appear in the expression for the second variation of the potential energy. Hence, consideration will be directed only to the evaluation of the strain energy of the element.

The geometry of the doubly curved, thin shell, finite element is depicted in Figure III-1a. The middle surface of the element is defined by the curvilinear coordinate  $\xi_1$  and  $\xi_2$ . The coordinate  $\xi_3$  is normal to the middle surface and completes the orthogonal right-handed system. The radii of curvature  $R_1$  and  $R_2$ , corresponding to the coordinate lines  $\xi_1$  and  $\xi_2$  respectively, are constants. The equation for the differential distance,  $ds$ , between two points on the middle surface is

$$ds^2 = \alpha_1^2 d\xi_1^2 + \alpha_2^2 d\xi_2^2 \quad (\text{III-1})$$

where  $\alpha_1$  and  $\alpha_2$  are the Lamé parameters. The linear displacements  $u$ ,  $v$ , and  $w$ , corresponding to the coordinate directions  $\xi_1$ ,  $\xi_2$  and  $\xi_3$  respectively, are as shown in Figure III-1b.



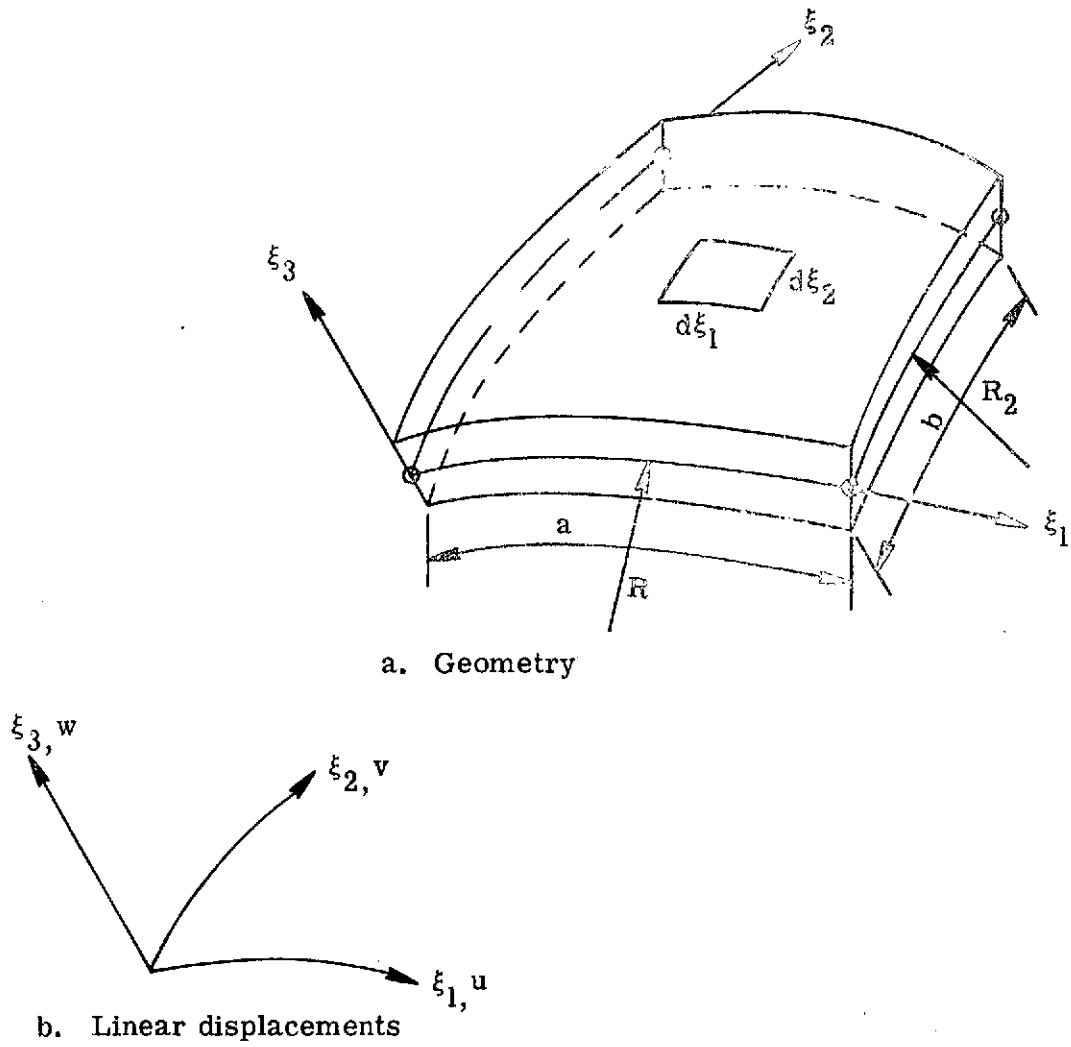

Figure III-1. Geometry and displacements of the doubly curved shell element.

The nonlinear strain displacement relations for small strains were derived by Sanders in reference 26 and will be used in the formulation of the strain energy expression. The nonlinear middle surface extensional and in plane shear strains are:

$$\begin{aligned} e_1 &= \epsilon_1 + \frac{\beta_1^2}{2} \\ e_2 &= \epsilon_2 + \frac{\beta_2^2}{2} \end{aligned} \quad \text{(III-2)}$$

$$e_{12} = \gamma_{12} + \beta_1\beta_2$$

where

$$\epsilon_1 = \frac{1}{\alpha_1} \frac{\partial u}{\partial \xi_1} + \frac{w}{R_1}$$

$$\epsilon_2 = \frac{1}{\alpha_2} \frac{\partial v}{\partial \xi_2} + \frac{w}{R_2}$$

$$\gamma_{12} = \frac{1}{\alpha_1} \frac{\partial v}{\alpha \xi_1} + \frac{1}{\alpha_2} \frac{\partial u}{\xi_2}$$

$$\beta_1 = -\frac{1}{\alpha_1} \frac{\partial w}{\partial \xi_1} + \frac{u}{R_1}$$

$$\beta_2 = -\frac{1}{\alpha_2} \frac{\partial w}{\partial \xi_2} + \frac{v}{R_2}$$

The expressions for the bending distortion are:

$$\chi_1 = -\frac{1}{\alpha_1^2} \frac{\partial^2 w}{\partial \xi_1^2} + \frac{1}{\alpha_1 R_1} \frac{\partial u}{\partial \xi_1} \quad \text{(III-3)}$$

$$\chi_2 = -\frac{1}{\alpha_2^2} \frac{\partial^2 w}{\partial \xi_2^2} + \frac{1}{\alpha_2 R_2} \frac{\partial v}{\partial \xi_2}$$

$$\chi_{12} = -\frac{2}{\alpha_1 \alpha_2} \frac{\partial^2 w}{\partial \xi_1 \partial \xi_2} + \frac{3}{2} \left( \frac{1}{\alpha_1 R_2} \frac{\partial v}{\partial \xi_1} + \frac{1}{\alpha_2 R_1} \frac{\partial u}{\partial \xi_2} \right) - \frac{1}{2} \left( \frac{1}{\alpha_2 R_2} \frac{\partial u}{\partial \xi_2} + \frac{1}{\alpha_1 R_1} \frac{\partial v}{\partial \xi_1} \right)$$

The expression for the strain energy for the doubly curved shell selement of Figure III-1a, expressed as integrals over the middle surface area, is (ref. 19)

$$\begin{aligned}
 U = & \frac{Eh}{2(1-\nu^2)} \iint_{\text{area}} \left[ e_1^2 + e_2^2 + 2\nu e_1 e_2 + \frac{(1-\nu)}{2} e_{12}^2 \right] \alpha_1 \alpha_2 d\xi_1 d\xi_2 \\
 & + \frac{Eh^3}{24(1-\nu^2)} \iint_{\text{area}} \left[ \chi_1^2 + \chi_2^2 + 2\nu \chi_1 \chi_2 + \frac{(1-\nu)}{2} \chi_{12}^2 \right] \alpha_1 \alpha_2 d\xi_1 d\xi_2
 \end{aligned} \tag{III-4}$$

The total strain energy is seen to be the sum of the membrane energy, given by the first integral, and the bending energy, given by the second integral.

The stress components in the shell element are shown in Figure III-2a. The corresponding stress resultants and bending moments are shown in their positive directions in figures III-2b and III-2c. The following set of equations relate the stress resultants to membrane strains and the bending moments to bending distortions (ref. 19).

$$\begin{aligned}
 N_1 &= \frac{Eh}{1-\nu^2} (e_1 + \nu e_2) \\
 N_2 &= \frac{Eh}{1-\nu^2} (e_2 + \nu e_1) \\
 N_{12} &= N_{21} = Gh e_{12} \\
 M_1 &= \frac{Eh^3}{12(1-\nu^2)} (\chi_1 + \nu \chi_2) \\
 M_2 &= \frac{Eh^3}{12(1-\nu^2)} (\chi_2 + \nu \chi_1) \\
 M_{12} &= M_{21} = \frac{Eh^3}{24(1-\nu)} \chi_{12}
 \end{aligned} \tag{III-5}$$

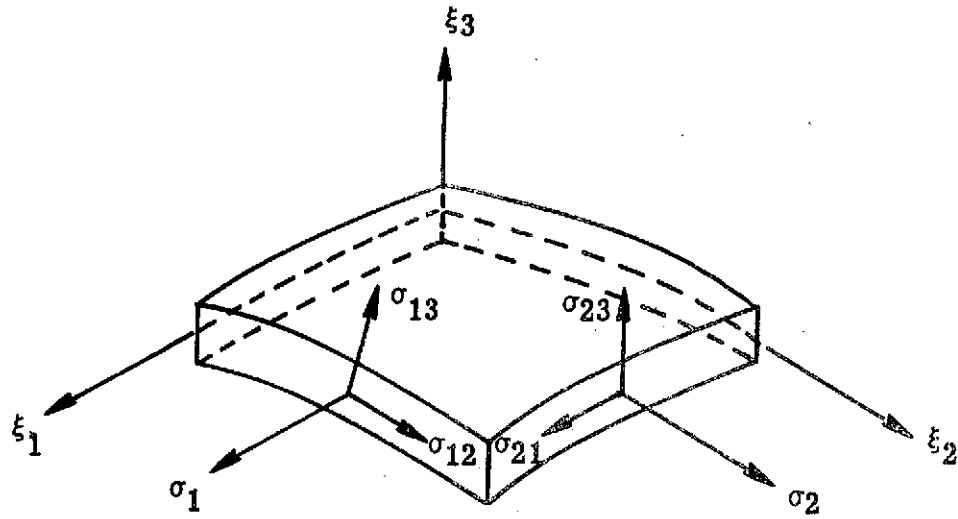

a. Stress components

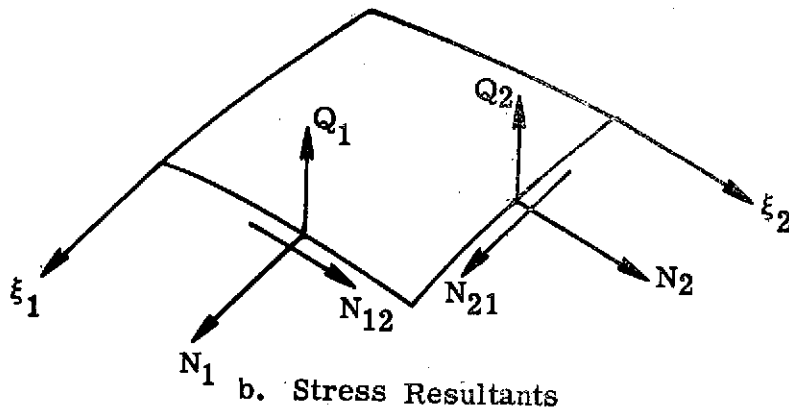

b. Stress Resultants

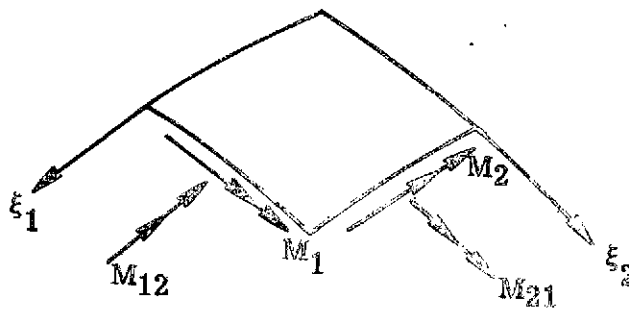

c. Bending Moments

Figure III-2. Internal Stresses

By combining equations III-2 and III-5 with equation III-4, the following form of the strain energy expression is obtained:

$$U = \frac{1}{2} \iint_{\text{area}} \left[ N_1 \left( \epsilon_1 + \frac{\beta_1^2}{2} \right) + N_2 \left( \epsilon_2 + \frac{\beta_2^2}{2} \right) + N_{12} (\gamma_{12} + \beta_1 \beta_2) + M_1 X_1 + M_2 X_2 + M_{12} X_{12} \right] \alpha_1 \alpha_2 d\xi_1 d\xi_2 \quad (\text{III-6})$$

### III.-3 The Second Variation of the Potential Energy

The strain energy of the shell element after a virtual displacement may be expressed as (ref. 19)

$$U + \Delta U = U + \delta U + \frac{1}{2!} \delta^2 U + \text{High Order Terms} \quad (\text{III-7})$$

in which  $\delta U$  and  $\delta^2 U$  are the first and second variations, respectively, of the strain energy. Hence, following the technique used in Chapter II, the second variation of the strain energy will be determined by giving the system a virtual displacement and grouping the terms in the resulting strain energy expression in the form of equation III-7. Applying a virtual displacement to the terms in equation III-7 produces the following equation:

$$U + \Delta U = \frac{1}{2} \iint_{\text{area}} \left\{ (N_1 + \Delta N_1) \left[ \epsilon_1 + \delta \epsilon_1 + \frac{(\beta_1 + \delta \beta_1)^2}{2} \right] + (N_2 + \Delta N_2) \left[ \epsilon_2 + \delta \epsilon_2 + \frac{(\beta_2 + \delta \beta_2)^2}{2} \right] + (N_{12} + \Delta N_{12}) \left[ \gamma_{12} + \delta \gamma_{12} + (\beta_1 + \delta \beta_1)(\beta_2 + \delta \beta_2) \right] + (\alpha_1 + \delta \alpha_1)(M_1 + \Delta M_1) + (\alpha_2 + \delta \alpha_2)(M_2 + \Delta M_2) + (\alpha_1 \alpha_2 + \delta \alpha_1 \alpha_2)(X_{12} + \Delta X_{12}) \right\} \alpha_1 \alpha_2 d\xi_1 d\xi_2 \quad (\text{III-8})$$

Evaluating the incremental stress resultants and moments:

$$\begin{aligned}
 N_1 + \Delta N_1 &= \frac{Eh}{1-\nu^2} \left\{ \varepsilon_1 + \delta\varepsilon_1 + \frac{(\beta_1 + \delta\beta_1)^2}{2} + \nu \left[ \varepsilon_2 + \delta\varepsilon_2 + \frac{(\beta_2 + \delta\beta_2)^2}{2} \right] \right\} \\
 &= \frac{Eh}{1-\nu^2} \left\{ \varepsilon_1 + \delta\varepsilon_1 + \frac{\beta_1^2}{2} + \beta_1 \delta\beta_1 + \frac{\delta^2\beta_1}{2} + \nu\varepsilon_2 + \frac{\nu\beta_2^2}{2} \right. \\
 &\quad \left. + \nu\beta_2 \delta\beta_2 + \nu \frac{\delta^2\beta_2}{2} \right\}
 \end{aligned}$$

Comparing this with the first of equations III-5, it is determined that:

$$\Delta N_1 = \frac{Eh}{1-\nu^2} \left[ \delta\varepsilon_1 + \beta_1 \delta\beta_1 + \nu\delta\varepsilon_2 + \nu\beta_1 \delta\beta_1 + \frac{\delta^2\beta_1}{2} + \frac{\nu\delta^2\beta_2}{2} \right] \quad (\text{III-9})$$

Similarly

$$\Delta N_2 = \frac{Eh}{1-\nu^2} \left[ \delta\varepsilon_2 + \beta_2 \delta\beta_2 + \nu\delta\varepsilon_1 + \nu\beta_2 \delta\beta_2 + \frac{\delta^2\beta_2}{2} + \frac{\nu\delta^2\beta_1}{2} \right] \quad (\text{III-10})$$

$$\Delta N_{12} = \frac{Eh}{2(1+\nu)} \left[ \delta\gamma_{12} + \beta_1 \delta\beta_2 + \beta_2 \delta\beta_1 + \delta\beta_1 \delta\beta_2 \right] \quad (\text{III-11})$$

$$\Delta M_1 = \frac{Eh^3}{12(1-\nu^3)} (\delta X_1 + \nu\delta X_2) \quad (\text{III-12})$$

$$\Delta M_2 = \frac{Eh^3}{12(1-\nu^2)} [\delta X_2 + \nu\delta X_1] \quad (\text{III-13})$$

$$\Delta M_{12} = \frac{Eh^3}{24(1-\nu)} \delta X_{12} \quad (\text{III-14})$$

After substituting equations III-9 through III-14 into equation III-8 and after considerable manipulation, the second variation of the potential energy, which is equal to the second variation of the strain energy, may be identified and written in matrix form as:

$$\delta^2 \pi = \iint_{\text{area}} \{\delta \bar{\epsilon}\}^T \frac{Eh}{1-\nu^2} [\hat{K}^0] \{\delta \bar{\epsilon}\} \alpha_1 \alpha_2 d\xi_1 d\xi_2 + \iint_{\text{area}} \{\delta \bar{\epsilon}\}^T [\hat{K}^1] \{\delta \bar{\epsilon}\} \alpha_1 \alpha_2 d\xi_1 d\xi_2$$

$$+ \iint_{\text{area}} \{\delta \bar{\epsilon}\} \frac{Eh}{1-\nu^2} [\hat{K}^2] \{\delta \bar{\epsilon}\} \alpha_1 \alpha_2 d\xi_1 d\xi_2 \quad (\text{III-15})$$

where

$$\{\delta \bar{\epsilon}\}^T = \left[ \delta \epsilon_1 \quad \delta \beta_1 \quad \delta \chi_1 \quad \delta \gamma_{12} \quad \delta \epsilon_2 \quad \delta \beta_2 \quad \delta \chi_2 \quad \delta \chi_{12} \right]$$

$$[\hat{K}^0] = \begin{bmatrix} \delta \epsilon_1 & \delta \beta_1 & \delta \chi_1 & \delta \gamma_{12} & \delta \epsilon_2 & \delta \beta_2 & \delta \chi_2 & \delta \chi_{12} \\ 1 & 0 & 0 & 0 & \nu & 0 & 0 & 0 \\ 0 & 0 & 0 & 0 & 0 & 0 & 0 & 0 \\ 0 & 0 & \frac{h^2}{12} & 0 & 0 & 0 & \frac{\nu h^2}{12} & 0 \\ 0 & 0 & 0 & \frac{1-\nu}{2} & 0 & 0 & 0 & 0 \\ \nu & 0 & 0 & 0 & 1 & 0 & 0 & 0 \\ 0 & 0 & 0 & 0 & 0 & 0 & 0 & 0 \\ 0 & 0 & \frac{\nu h^2}{12} & 0 & 0 & 0 & \frac{h^2}{12} & 0 \\ 0 & 0 & 0 & 0 & 0 & 0 & 0 & \frac{h^2(1-\nu)}{24} \end{bmatrix}$$

$$[\hat{K}^1] = \begin{bmatrix} 0 & 0 & 0 & 0 & 0 & 0 & 0 & 0 \\ 0 & N_1 & 0 & 0 & 0 & N_{12} & 0 & 0 \\ 0 & 0 & 0 & 0 & 0 & 0 & 0 & 0 \\ 0 & 0 & 0 & 0 & 0 & 0 & 0 & 0 \\ 0 & 0 & 0 & 0 & 0 & 0 & 0 & 0 \\ 0 & N_{12} & 0 & 0 & 0 & N_2 & 0 & 0 \\ 0 & 0 & 0 & 0 & 0 & 0 & 0 & 0 \\ 0 & 0 & 0 & 0 & 0 & 0 & 0 & 0 \end{bmatrix}$$

$$[\hat{K}^2] = \begin{bmatrix} 0 & \beta_1 & 0 & 0 & 0 & \nu \beta_2 & 0 & 0 \\ \beta_1 & \beta_1^2 + \left(\frac{1-\nu}{2}\right) \beta_2^2 & 0 & \left(\frac{1-\nu}{2}\right) \beta_2 & \nu \beta_1 & \left(\frac{1+\nu}{2}\right) \beta_1 \beta_2 & 0 & 0 \\ 0 & 0 & 0 & 0 & 0 & 0 & 0 & 0 \\ 0 & \left(\frac{1-\nu}{2}\right) \beta_2 & 0 & 0 & 0 & \left(\frac{1-\nu}{2}\right) \beta_1 & 0 & 0 \\ 0 & \nu \beta_1 & 0 & 0 & 0 & \beta_2 & 0 & 0 \\ \nu \beta_2 & \left(\frac{1+\nu}{2}\right) \beta_1 \beta_2 & 0 & \left(\frac{1-\nu}{2}\right) \beta_1 & \beta_2 & \beta_2^2 + \left(\frac{1-\nu}{2}\right) \beta_1^2 & 0 & 0 \\ 0 & 0 & 0 & 0 & 0 & 0 & 0 & 0 \\ 0 & 0 & 0 & 0 & 0 & 0 & 0 & 0 \end{bmatrix}$$

The first term in Equation III-15 leads to the conventional stiffness matrix; the second term leads to the initial stress stiffness matrix; and the third term leads to the initial displacement stiffness matrix.

#### III.-4 The Stiffness Matrix

The formulation of a stiffness matrix for the doubly curved shell element shown in Figure III-1a is described in detail in reference 25 and will not be repeated here. The stiffness matrix reported in reference 25 specialized to the case of the element shown in Figure III-3a, will be used. The relationship of the coordinate axes of the cylindrical element to those of the doubly curved element is:

$$\xi_1 = X \quad \text{(III-16)}$$

$$\xi_2 = \theta$$

$$\xi_3 = Z$$

The radii of curvature for the cylindrical element are:

$$R_1 = \infty \quad \text{(III-17)}$$

$$R_2 = R$$

The Lamé parameters for the cylindrical element are:

$$\alpha_1 = 1 \quad \text{(III-18)}$$

$$\alpha_2 = R$$

Figures III-3a and III-3b depict the positive directions for the linear and angular displacement in the cylindrical element.

Because of the importance of the assumed displacement function in the development of any finite element stiffness matrix; it is worthwhile to briefly discuss the displacement functions used by Gallagher



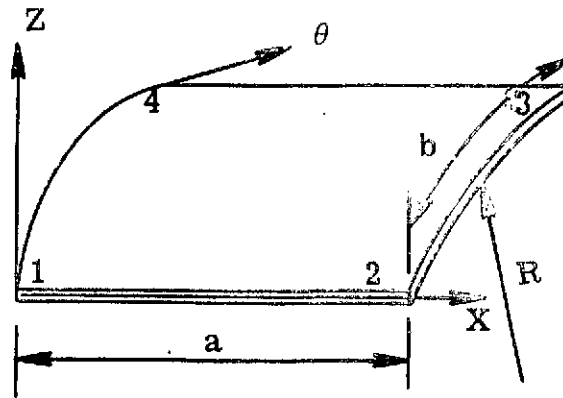

a. Element Geometry

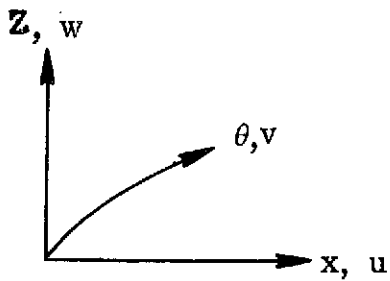

b. Linear Displacements

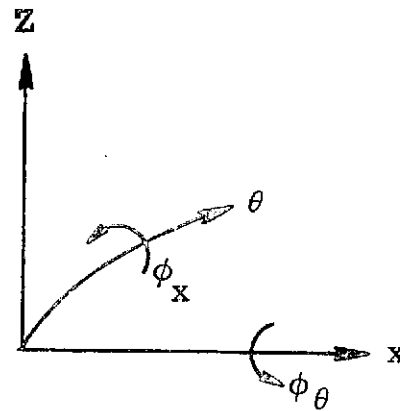

c. Angular Displacements

Figure III-3. Geomertry of the cylindrical element and associated displacements.

for the doubly curved shell element. The displacement functions used by Gallagher in reference 25 are:

$$u = \frac{1}{ab} [(X-a)(R\theta-b)u_1 - X(R\theta-b)u_2 + XR\theta u_3 - R\theta(X-a)u_4]$$

$$v = \frac{1}{ab} [(X-a)(R\theta-b)v_1 - X(R\theta-b)v_2 + XR\theta v_3 - R\theta(X-a)v_4]$$

$$w = \frac{1}{a^3b^3} \left\{ (a^3+2X^3-3aX^2) [b^3+2(R\theta)^3-3b(R\theta)^2] w_1 + (3aX^2-2X^3) [b^3+2(R\theta)^3-3bR\theta^2] w_2 \right. \\ + (3aX^2-2X^3) [3b(R\theta)^2-2(R\theta)^3] w_3 + (a^3+2X^3-3aX^2) [3b(R\theta)^2-2(R\theta)^3] w_4 \\ + aX(X-a)^2 [b^3-2(R\theta)^3-3b(R\theta)^2] \phi_{X_1} + a(X^3-aX^3) [b^3+2(R\theta)^3-3b(R\theta)^2] \phi_{X_2} \\ + a(X^3-aX^2) [3b(R\theta)^2-2(R\theta)^3] \phi_{X_3} + a(X-a)^2 X [3b(R\theta)^2-2(R\theta)^3] \phi_{X_4} \\ + b(a^3+2X^3-3aX^2) R\theta [(R\theta)-b]^2 \phi_{\theta_1} - b(3aX^2-2X^3) R\theta [(R\theta)-b]^2 \phi_{\theta_2} \\ + b(3aX^2-2X^3) [(R\theta)^3-b(R\theta)^2] \phi_{\theta_3} + b(a^3+2X^3-3aX^2) [(R\theta)^3-b(R\theta)^2] \phi_{\theta_4} \\ + abXR\theta(X-a)^2 [(R\theta)-b]^2 \phi_{X\theta_1} + abXR\theta(X^2-aX) [(R\theta)-b]^2 \phi_{X\theta_2} \\ \left. + abXR\theta(X^2-aX) [(R\theta)^2-bR\theta] \phi_{X\theta_3} + abXR\theta(X-a)^2 [(R\theta)^2-bR\theta] \phi_{X\theta_4} \right\}$$

where, as shown in Figure III-3, a and b are the element lengths in the meridional and hoop directions respectively;  $u_i$ ,  $v_i$  and  $w_i$  ( $i=1,2,3,4$ ) are the linear displacements at the  $i^{\text{th}}$  corner of the element and;  $\phi_{X_i}$ ,  $\phi_{\theta_i}$  and  $\phi_{X\theta_i}$  are the angular displacements at the  $i^{\text{th}}$  corner of the element.

Zienkiewicz and Cheung in reference 27 list the desirable conditions to be met by a displacement function chosen to represent element behavior. These conditions are that the displacement function must properly account for rigid body motion and constant strain rates, and must satisfy inter-element boundaries. The above displacement functions meet these conditions in the case of a flat plate but fail to do so in the case of the curved element.

Previous studies (ref. 28 and 29) indicate that the violation of the above conditions does not prevent convergence to the classical solution and does not significantly reduce accuracy for refined idealizations. Indeed, Gallagher demonstrates the adequacy of his formulation by showing excellent correlations with known closed form solutions to several shell problems.

Table III-1 shows the organization of the terms in the conventional, initial stress and initial displacement stiffness matrices. The explicit statement of the terms in the element stiffness matrix,  $[K_e^0]$ , obtained by Gallagher and specialized to the cylindrical element is given in Table III-2.



Table III-2 Elements of  $[K_e^0]$ 

$$k_{1,1}^0 = k_{7,7}^0 = k_{13,13}^0 = k_{19,19}^0 = D_m \left[ \frac{b}{3a} + \frac{(1-\nu)}{6} \frac{a}{b} \right]$$

$$k_{2,1}^0 = k_{14,13}^0 = k_{20,7}^0 = k_{19,8}^0 = \frac{D_m(1+\nu)}{8}$$

$$k_{3,1}^0 = k_{9,1}^0 = k_{19,15}^0 = k_{21,19}^0 = \frac{-7\nu b D_m}{40R}$$

$$k_{4,1}^0 = k_{10,7}^0 = k_{16,13}^0 = k_{22,19}^0 = \frac{a}{6} k_{3,1}^0$$

$$k_{5,1}^0 = k_{11,1}^0 = k_{17,13}^0 = k_{23,13}^0 = \frac{-b^2 \nu D_m}{40R}$$

$$k_{6,1}^0 = k_{12,7}^0 = k_{24,13}^0 = k_{19,13}^0 = \frac{a}{6} k_{5,1}^0$$

$$k_{7,1}^0 = k_{19,13}^0 = -D_m \left[ \frac{b}{3a} - \frac{(1-\nu)a}{12b} \right]$$

$$k_{8,1}^0 = k_{19,2}^0 = k_{14,7}^0 = k_{20,13}^0 = -\frac{D_m(1-3\nu)}{8}$$

$$k_{10,1}^0 = k_{22,13}^0 = k_{19,16}^0 = k_{7,4}^0 = -k_{4,1}^0$$

$$k_{12,1}^0 = k_{7,6}^0 = k_{18,13}^0 = k_{24,19}^0 = -k_{6,1}^0$$

$$k_{13,1}^0 = k_{19,7}^0 = -\frac{k_{1,1}^0}{2}$$

$$k_{14,1}^0 = k_{13,2}^0 = k_{8,7}^0 = k_{20,19}^0 = -k_{2,1}^0$$

$$k_{15,1}^0 = k_{21,1}^0 = k_{19,3}^0 = k_{19,9}^0 = -\frac{3\nu b D_m}{40R}$$

$$k_{16,1}^0 = k_{13,4}^0 = k_{22,7}^0 = k_{19,10}^0 = \frac{ab\nu D_m}{8R}$$

Table III-2 (Continued)

$$k_{17,1}^0 = k_{23,1}^0 = k_{13,11}^0 = k_{13,5}^0 = \frac{b^2 \nu D_m}{60R}$$

$$k_{18,1}^0 = k_{19,6}^0 = k_{24,7}^0 = k_{13,12}^0 = \frac{a}{9} k_{5,1}^0$$

$$k_{19,1}^0 = k_{13,7}^0 = D_m \left[ \frac{b}{6a} - (1-\nu) \frac{a}{6b} \right]$$

$$k_{20,1}^0 = k_{7,2}^0 = k_{13,8}^0 = k_{19,14}^0 = -k_{8,1}^0$$

$$k_{22,1}^0 = k_{19,4}^0 = k_{16,7}^0 = k_{13,10}^0 = -k_{16,1}^0$$

$$k_{24,1}^0 = k_{13,6}^0 = k_{18,7}^0 = k_{19,12}^0 = -k_{18,1}^0$$

$$k_{2,2}^0 = k_{8,8}^0 = k_{14,14}^0 = k_{20,20}^0 = D_m \left\{ \frac{a}{3b} \left[ 1 + \frac{D_b}{D_m R^2} \right] + \frac{1-\nu}{6} \frac{b}{a} \left[ 1 + 4 \frac{D_b}{D_m R^2} \right] \right\}$$

$$k_{3,2}^0 = k_{9,8}^0 = \frac{-7aD_m}{40R} + \frac{(2-3\nu)}{2aR} D_b$$

$$k_{4,2}^0 = k_{22,2}^0 = k_{14,10}^0 = k_{16,14}^0 = -\frac{a^2 D_m}{40R} - \frac{\nu D_b}{2R}$$

$$k_{5,2}^0 = k_{11,8}^0 = k_{17,14}^0 = k_{23,20}^0 = -\frac{7abD_m}{240R} - \frac{(2-\nu)bD_b}{12aR} - \frac{7aD_b}{20bR}$$

$$k_{6,2}^0 = k_{18,8}^0 = k_{14,12}^0 = k_{24,20}^0 = -\frac{a^2 b D_m}{240R} - \frac{\nu b D_b}{12R} - \frac{a^2 D_b}{20bR}$$

$$k_{8,2}^0 = k_{20,4}^0 = D_m \left\{ \frac{a}{6b} \left[ 1 + \frac{D_b}{D_m R^2} \right] - (1-\nu) \frac{b}{a} \left[ 1 + 4 \frac{D_b}{D_m R^2} \right] \right\}$$

$$k_{9,2}^0 = k_{8,3}^0 = -\frac{3aD_m}{40R} - \frac{(2-3\nu)D_b}{2aR}$$

Table III - 2 (Continued)

$$k_{10,2}^0 = k_{16,2}^0 = k_{14,4}^0 = k_{22,14}^0 = \frac{D_m a^2}{60R}$$

$$k_{11,2}^0 = k_{8,5}^0 = k_{23,14}^0 = k_{20,17}^0 = -\frac{abD_m}{80R} + \frac{(2-\nu)bD_b}{12aR} - \frac{3aD_b}{20bR}$$

$$k_{12,2}^0 = k_{14,6}^0 = k_{24,8}^0 = k_{20,16}^0 = \frac{a^2bD_m}{360R} + \frac{a^2D_b}{30bR}$$

$$k_{14,2}^0 = k_{20,8}^0 = -\frac{k_{2,2}^0}{2}$$

$$k_{15,2}^0 = k_{21,8}^0 = -\frac{3aD_m}{40R} + \frac{(2-\nu)D_b}{2aR}$$

$$k_{17,2}^0 = k_{14,5}^0 = k_{23,8}^0 = k_{20,11}^0 = -k_{11,2}^0$$

$$k_{18,2}^0 = k_{8,6}^0 = k_{20,12}^0 = k_{24,14}^0 = -k_{12,2}^0$$

$$k_{20,2}^0 = k_{14,8}^0 = -D_m \left\{ \frac{a}{3b} \left[ 1 + \frac{D_b}{D_m R^2} \right] - \frac{(1-\nu)b}{12a} \left[ 1 + \frac{4D_b}{D_m R^2} \right] \right\}$$

$$k_{21,2}^0 = k_{15,8}^0 = -\frac{7aD_m}{40R} - \frac{(2-\nu)D_m}{2aR}$$

$$k_{23,2}^0 = k_{20,5}^0 = k_{17,8}^0 = k_{19,11}^0 = -k_{5,2}^0$$

$$k_{24,2}^0 = k_{20,6}^0 = k_{12,8}^0 = k_{18,14}^0 = -k_{6,2}^0$$

$$k_{3,3}^0 = k_{9,9}^0 = k_{15,15}^0 = k_{21,21}^0 = \frac{156D_b}{35} \left[ \frac{b}{a^3} + \frac{a}{b^3} \right] + \frac{72D_b}{25ab} + \frac{169abD_m}{1225R^2}$$

$$k_{4,3}^0 = k_{22,21}^0 = a \left\{ D_b \left[ \frac{73b}{35a^3} + \frac{22a}{35b^3} + \frac{1}{ab} \left( \frac{6}{25} + \frac{6\nu}{5} \right) \right] + \frac{143abD_m}{7350R^2} \right\}$$

Table III-2(Continued)

$$k_{5,3}^0 = k_{11,9}^0 = b \left\{ D_b \left[ \frac{22b}{35a^3} + \frac{73a}{35b^3} + \frac{1}{ab} \left( \frac{6}{25} + \frac{6v}{5} \right) \right] + \frac{143ab}{7350} \frac{D_m}{R^2} \right\}$$

$$k_{6,3}^0 = k_{18,5}^0 = ab \left\{ D_b \left[ \frac{11b}{35a^3} + \frac{11a}{35b^3} + \frac{1}{ab} \left( \frac{1}{50} + \frac{v}{5} \right) \right] + \frac{121ab}{44100} \frac{D_m}{R^2} \right\}$$

$$k_{7,3}^0 = k_{9,7}^0 = k_{15,13}^0 = k_{21,13}^0 = -k_{3,1}^0$$

$$k_{7,3}^0 = k_{21,15}^0 = -D_b \left[ \frac{156b}{35a^3} - \frac{54a}{35b^3} + \frac{72}{25ab} \right] + \frac{117ab}{2450} \frac{D_m}{R^2}$$

$$k_{10,3}^0 = k_{21,16}^0 = a \left\{ D_b \left[ \frac{78b}{35a^3} - \frac{13a}{35b^3} + \frac{6}{25ab} \right] - \frac{169ab}{14700} \frac{D_m}{R^2} \right\}$$

$$k_{11,3}^0 = k_{9,5}^0 = b \left\{ D_b \left[ -\frac{22b}{35a^3} + \frac{27a}{35b^3} - \frac{1}{ab} \left( \frac{6}{25} + \frac{6v}{5} \right) \right] + \frac{33ab}{4900} \frac{D_m}{R^2} \right\}$$

$$k_{12,3}^0 = k_{24,15}^0 = ab \left\{ D_b \left[ \frac{11b}{35a^3} - \frac{12a}{70b^3} + \frac{1}{ab} \left( \frac{1}{50} - \frac{v}{10} \right) \right] - \frac{143ab}{88200} \frac{D_m}{R^2} \right\}$$

$$k_{13,3}^0 = k_{15,7}^0 = k_{21,7}^0 = k_{13,9}^0 = -k_{15,1}^0$$

$$k_{14,3}^0 = k_{20,9}^0 = -k_{15,2}^0$$

$$k_{15,3}^0 = k_{21,9}^0 = -\frac{54}{35} D_b \left[ \frac{b}{a^3} + \frac{a}{b^3} \right] + \frac{72}{25} \frac{D_b}{ab} + \frac{81ab}{4900} \frac{D_m}{R^2}$$

$$k_{16,3}^0 = k_{21,10}^0 = a \left\{ D_b \left[ \frac{37b}{35a^3} + \frac{13a}{35b^3} - \frac{6}{25ab} \right] - \frac{39ab}{9800} \frac{D_m}{R^2} \right\}$$

$$k_{17,3}^0 = k_{23,9}^0 = b \left\{ D_b \left[ \frac{13b}{35a^3} + \frac{27a}{35b^3} - \frac{6}{25ab} \right] - \frac{39ab}{9800} \frac{D_m}{R^2} \right\}$$



TABLE III-2 (Continued)

$$k_{18,3}^0 = k_{15,6}^0 = ab \left\{ D_b \left[ \frac{13}{70} \frac{b}{a^3} - \frac{13}{70} \frac{a}{b^3} + \frac{1}{50ab} \right] + \frac{169ab}{176400} \frac{D_m}{R^2} \right\}$$

$$k_{20,3}^0 = k_{14,9}^0 = -k_{21,2}^0$$

$$k_{21,3}^0 = k_{15,9}^0 = D_b \left[ \frac{54}{35} \frac{b}{a^3} - \frac{156}{35} \frac{a}{b^3} - \frac{72}{25ab} \right] + \frac{117ab}{2450} \frac{D_m}{R^2}$$

$$k_{22,3}^0 = k_{21,4}^0 = a \left\{ D_b \left[ \frac{27}{35} \frac{b}{a^3} - \frac{22}{35} \frac{a}{b^3} - \frac{1}{ab} \left( \frac{6}{25} + \frac{6\nu}{5} \right) \right] + \frac{33ab}{4900} \frac{D_m}{R^2} \right\}$$

$$k_{23,3}^0 = k_{17,9}^0 = b \left\{ D_b \left[ -\frac{13}{35} \frac{b}{a^3} + \frac{78}{35} \frac{a}{b^3} + \frac{6}{25ab} \right] - \frac{169ab}{14700} \frac{D_m}{R^2} \right\}$$

$$k_{24,3}^0 = k_{15,12}^0 = ab \left\{ D_b \left[ -\frac{13}{70} \frac{b}{a^3} + \frac{11}{35} \frac{a}{b^3} + \frac{1}{ab} \left( \frac{1}{50} + \frac{\nu}{10} \right) \right] - \frac{143ab}{88200} \frac{D_m}{R^2} \right\}$$

$$k_{4,4}^0 = k_{10,10}^0 = k_{16,16}^0 = k_{22,22}^0 = a^2 \left\{ D_b \left[ \frac{52}{35} \frac{b}{a^3} + \frac{4}{35} \frac{a}{b^3} + \frac{3}{25ab} \right] + \frac{13ab}{3675} \frac{D_m}{R^2} \right\}$$

$$k_{5,4}^0 = k_{17,16}^0 = ab \left\{ D_b \left[ \frac{11}{35} \frac{b}{a^3} + \frac{11}{35} \frac{a}{b^3} + \frac{1}{ab} \left( \frac{1}{50} + \frac{6\nu}{5} \right) \right] + \frac{121ab}{44100} \frac{D_m}{R^2} \right\}$$

$$k_{6,4}^0 = k_{12,10}^0 = a^2 b \left\{ D_b \left[ \frac{22}{105} \frac{b}{a^3} + \frac{2}{35} \frac{a}{b^3} + \frac{2}{ab} \left( \frac{1}{75} + \frac{\nu}{15} \right) \right] + \frac{11ab}{22050} \frac{D_m}{R^2} \right\}$$

$$k_{8,4}^0 = k_{22,8}^0 = k_{20,0}^0 = k_{20,16}^0 = -k_{10,2}^0$$

$$k_{9,4}^0 = k_{22,15}^0 = -k_{10,3}^0$$

$$k_{10,4}^0 = k_{22,16}^0 = a^2 \left\{ D_b \left[ \frac{26}{35} \frac{b}{a^3} - \frac{3}{35} \frac{a}{b^3} - \frac{2}{25ab} \right] - \frac{13ab}{4900} \frac{D_m}{R^2} \right\}$$

$$k_{11,4}^0 = k_{23,16}^0 = ab \left\{ D_b \left[ -\frac{11}{35} \frac{b}{a^3} - \frac{13}{70} \frac{a}{b^3} - \frac{1}{ab} \left( \frac{1}{50} + \frac{\nu}{10} \right) \right] + \frac{143ab}{88200} \frac{D_m}{R^2} \right\}$$

TABLE III-2 (Continued)

$$k_{12,4}^0 = k_{10,6}^0 = a^2 b \left\{ D_b \left[ \frac{11}{105} \frac{b}{a^3} - \frac{3}{70} \frac{a}{b^3} - \frac{1}{ab} \left( \frac{1}{150} + \frac{\nu}{30} \right) \right] - \frac{11ab}{29400} \frac{D_m}{R^2} \right\}$$

$$k_{15,4}^0 = k_{22,9}^0 = -k_{16,3}^0$$

$$k_{16,4}^0 = k_{22,10}^0 = a^2 \left\{ D_b \left[ \frac{9}{35} \frac{b}{a^3} + \frac{3}{35} \frac{a}{b^3} + \frac{2}{25ab} \right] - \frac{9ab}{9800} \frac{D_m}{R^2} \right\}$$

$$k_{17,4}^0 = k_{16,5}^0 = ab \left\{ D_b \left[ \frac{13}{70} \frac{b}{a^3} + \frac{13}{70} \frac{a}{b^3} - \frac{1}{50ab} \right] - \frac{169ab}{176400} \frac{D_m}{R^2} \right\}$$

$$k_{18,4}^0 = k_{24,10}^0 = a^2 b \left\{ D_b \left[ -\frac{13}{210} \frac{b}{a^3} - \frac{3}{70} \frac{a}{b^3} - \frac{1}{150ab} \right] + \frac{13ab}{77800} \frac{D_m}{R^2} \right\}$$

$$k_{20,4}^0 = k_{10,5}^0 + k_{16,8}^0 = k_{22,20}^0 = -k_{4,2}^0$$

$$k_{22,4}^0 = k_{16,10}^0 = a^2 \left\{ D_b \left[ \frac{18}{35} \frac{b}{a^3} - \frac{4}{35} \frac{a}{b^3} - \frac{8}{25ab} \right] + \frac{3ab}{2450} \frac{D_m}{R^2} \right\}$$

$$k_{23,4}^0 = k_{16,11}^0 = ab \left\{ D_b \left[ -\frac{13}{70} \frac{b}{a^3} + \frac{11}{35} \frac{a}{b^3} + \frac{1}{ab} \left( \frac{1}{50} + \frac{\nu}{10} \right) \right] - \frac{143ab}{88200} \frac{D_m}{R^2} \right\}$$

$$k_{24,4}^0 = k_{18,10}^0 = a^2 b \left\{ D_b \left[ -\frac{13}{105} \frac{b}{a^3} + \frac{2}{35} \frac{a}{b^3} + \frac{2}{75ab} \right] - \frac{13ab}{44100} \frac{D_m}{R^2} \right\}$$

$$k_{5,5}^0 = k_{11,11}^0 = k_{17,17}^0 = k_{23,23}^0 = b^2 \left\{ D_b \left[ \frac{4}{35} \frac{b}{a^3} + \frac{52}{35} \frac{a}{b^3} + \frac{8}{25ab} \right] + \frac{13ab}{3675} \frac{D_m}{R^2} \right\}$$

$$k_{6,5}^0 = k_{24,23}^0 = ab^2 \left\{ D_b \left[ \frac{2}{35} \frac{b}{a^3} + \frac{22}{105} \frac{a}{b^3} + \frac{2}{ab} \left( \frac{1}{75} + \frac{\nu}{15} \right) \right] + \frac{11ab}{22050} \frac{D_m}{R^2} \right\}$$

$$k_{7,5}^0 = k_{11,7}^0 = k_{23,19}^0 = k_{19,17}^0 = -k_{5,1}^0$$

$$k_{10,5}^0 = k_{22,17}^0 = -k_{11,4}^0$$

$$k_{11,5}^0 = k_{23,17}^0 = b^2 \left\{ D_b \left[ -\frac{4}{35} \frac{b}{a^3} + \frac{18}{35} \frac{a}{b^3} - \frac{8}{25ab} \right] + \frac{3ab}{2450} \frac{D_m}{R^2} \right\}$$

TABLE III-2 (Continued)

$$k_{12,5}^0 = k_{23,18}^0 = ab^2 \left\{ D_b \left[ \frac{2}{35} \frac{b}{a^3} - \frac{13}{105} \frac{a}{b^3} + \frac{2}{75ab} \right] - \frac{13ab}{44100} \frac{D_m}{R^2} \right\}$$

$$k_{15,5}^0 = k_{21,11}^0 = -k_{17,3}^0$$

$$k_{17,5}^0 = k_{23,11}^0 = b^2 \left\{ D_b \left[ \frac{3}{35} \frac{b}{a^3} + \frac{9}{35} \frac{a}{b^3} + \frac{2}{25ab} \right] - \frac{9ab}{9800} \frac{D_m}{R^2} \right\}$$

$$k_{18,5}^0 = k_{23,12}^0 = ab^2 \left\{ D_b \left[ -\frac{3}{70} \frac{b}{a^3} - \frac{13}{210} \frac{a}{b^3} - \frac{1}{150ab} \right] + \frac{13ab}{77800} \frac{D_m}{R^2} \right\}$$

$$k_{19,5}^0 = k_{17,7}^0 = k_{23,7}^0 = k_{19,11}^0 = -k_{17,1}^0$$

$$k_{21,5}^0 = k_{15,11}^0 = -k_{23,3}^0$$

$$k_{22,5}^0 = k_{17,10}^0 = -k_{23,4}^0$$

$$k_{23,5}^0 = k_{17,11}^0 = b^2 \left\{ D_b \left[ -\frac{3}{35} \frac{b}{a^3} + \frac{26}{35} \frac{a}{b^3} - \frac{2}{25ab} \right] - \frac{13ab}{4900} \frac{D_m}{R^2} \right\}$$

$$k_{24,5}^0 = k_{23,6}^0 = ab^2 \left\{ D_b \left[ -\frac{3}{70} \frac{b}{a^3} + \frac{11}{105} \frac{a}{b^3} - \frac{1}{ab} \left( \frac{1}{150} + \frac{\nu}{30} \right) \right] - \frac{11ab}{29400} \frac{D_m}{R^2} \right\}$$

$$k_{6,6}^0 = k_{12,12}^0 = k_{18,18}^0 = k_{24,24}^0 = a^2 b^2 \left\{ D_b \left[ \frac{4}{105} \frac{b}{a^3} + \frac{4}{125} \frac{a}{b^3} + \frac{8}{225ab} \right] + \frac{ab}{11025} \frac{D_m}{R^2} \right\}$$

$$k_{9,6}^0 = k_{21,18}^0 = -k_{12,3}^0$$

$$k_{11,6}^0 = k_{24,17}^0 = -k_{12,5}^0$$

$$k_{12,6}^0 = k_{24,18}^0 = a^2 b^2 \left\{ D_b \left[ \frac{2}{105} \frac{b}{a^3} - \frac{1}{35} \frac{a}{b^3} - \frac{2}{225ab} \right] - \frac{ab}{14700} \frac{D_m}{R^2} \right\}$$

$$k_{16,6}^0 = k_{22,12}^0 = -k_{18,4}^0$$

$$k_{17,6}^0 = k_{24,11}^0 = -k_{18,5}^0$$

$$k_{18,6}^0 = k_{24,12}^0 = a^2 b^2 \left\{ D_b \left[ -\frac{1}{70} \frac{b}{a^3} - \frac{1}{70} \frac{a}{b^3} + \frac{1}{450ab} \right] + \frac{ab}{19600} \frac{D_m}{R^2} \right\}$$

TABLE III-2 (Concluded)

$$k_{21,6}^0 = k_{18,9}^0 = -k_{24,3}^0$$

$$k_{22,6}^0 = k_{16,12}^0 = -k_{24,4}^0$$

$$k_{24,6}^0 = k_{18,12}^0 = a^2 b^2 \left\{ D_b \left[ -\frac{1}{35} \frac{b}{a^3} + \frac{2}{105} \frac{a}{b^3} - \frac{2}{225ab} \right] - \frac{ab}{14700} \frac{D_m}{R^2} \right\}$$

$$k_{10,9}^0 = k_{16,15}^0 = -k_{4,3}^0$$

$$k_{12,9}^0 = k_{24,21}^0 = -k_{6,3}^0$$

$$k_{16,9}^0 = k_{15,10}^0 = -k_{22,3}^0$$

$$k_{24,9}^0 = k_{21,21}^0 = -k_{18,3}^0$$

$$k_{11,10}^0 = k_{23,22}^0 = -k_{5,4}^0$$

$$k_{23,10}^0 = k_{22,11}^0 = -k_{17,4}^0$$

$$k_{12,11}^0 = k_{18,17}^0 = -k_{6,5}^0$$

$$k_{18,11}^0 = k_{17,12}^0 = -k_{24,5}^0$$

$$k_{15,14}^0 = k_{21,20}^0 = -k_{3,2}^0$$

$$k_{17,15}^0 = k_{23,21}^0 = -k_{5,3}^0$$

$$k_{20,15}^0 = k_{21,14}^0 = -k_{9,2}^0$$

$$k_{23,15}^0 = k_{21,17}^0 = -k_{11,3}^0$$

$$k_{18,16}^0 = k_{24,22}^0 = -k_{6,4}^0$$

$$k_{24,16}^0 = k_{22,18}^0 = -k_{12,4}^0$$

### III-5 The Initial Stress and Initial Displacement Stiffness Matrices

The steps involved in the development of the initial stress and initial displacement stiffness matrices for a cylindrical element will be outlined in this section. The detailed statement of the significant intermediate matrices involved in this development is in Appendix B. The matrix symbols used in this section agree with those in Appendix B.

The desired strain-displacement relations for a cylindrical shell are obtained from equations III-2 and III-3 by the direct substitution of equations III-16, III-17 and III-18. Written in matrix notation, the equations relating strains to linear displacements are:

$$\{\bar{\epsilon}\} = [A][D]\{g\} \quad (\text{III-20})$$

where

$$\{\bar{\epsilon}\}^T = \begin{bmatrix} \epsilon_x & \beta_x & \chi_x & \gamma_{x\theta} & \epsilon_\theta & \beta_\theta & \chi_\theta & \gamma_{\theta x} \end{bmatrix}$$

$$\{g\}^T = \begin{bmatrix} u & v & w \end{bmatrix}$$

The terms in the [A] matrix are all constants and [D] is a matrix of differential operators.

One of the major assumptions involved in the development of the initial stress and initial displacement stiffness matrices is the form of the displacement functions to be used. Three displacement components, u, v and w, must be characterized. The characterization of the membrane displacements, u and v, is based on the simple assumption of linear edge displacements. For a flat plate, this assumption insures compatibility

of displacements along lines bounding the elements. Making use of the approach taken in references 30 and 31, the displacement functions for  $u$  and  $v$  are:

$$u = \frac{1}{ab} \left[ (X-a)(R\theta-b)u_1 - X(R\theta-b)u_2 + XR\theta u_3 - R\theta(X-a)u_4 \right] \quad (\text{III-21})$$

$$v = \frac{1}{ab} \left[ (X-a)(R\theta-b)v_1 - X(R\theta-b)v_2 + XR\theta v_3 - R\theta(X-a)v_4 \right] \quad (\text{III-22})$$

In reference 6, Martin discusses the relative merits of linear versus cubic displacement functions for the case of a beam-column. He demonstrates that a linear function representing the normal displacement,  $w$ , of the beam-column is the simplest, nontrivial polynomial form consistent with the problem. The beam-column stability problem is formulated using a cubic displacement function for  $w$  to derive the conventional stiffness matrix and a linear displacement function for  $w$  to derive the initial stress stiffness matrix. This is effectively a superposition of a tension-compression member and a beam; with no interaction between the two. In the case of the beam, this has led to satisfactory results. In an analogous manner, the displacement function chosen for  $w$  in the case of the cylindrical element is:

$$w = \frac{1}{ab} \left[ (X-a)(R\theta-b)w_1 - X(R\theta-b)w_2 + XR\theta w_3 - R\theta(X-a)w_4 \right] \quad (\text{III-23})$$

The displacement functions, in matrix notation are:

$$\{g\} = [B]\{\Delta\} \quad (\text{III-24})$$

Where:

$$\{\Delta\}^T = \left[ u_1 \ u_2 \ u_3 \ u_4 \ v_1 \ v_2 \ v_3 \ v_4 \ w_1 \ w_2 \ w_3 \ w_4 \right]$$

and [B] is given in Appendix B.

Substituting equation III-24 into equation III-20 gives:

$$\{\bar{\epsilon}\} = [C]\{\Delta\} \quad (\text{III-25})$$

with [C] being given in Appendix B.

It follows directly that:

$$\{\delta\bar{\epsilon}\} = [C]\{\delta\Delta\} \quad (\text{III-26})$$

Substituting equation III-26 in the second term in equation III-15 and introducing the notation for the cylindrical element produces the following expression for the initial stress stiffness matrix,  $[K_e^1]$ .

$$[K_e^1] = \iint_{\text{area}} \{\delta\Delta\}^T [C]^T [\hat{K}^1] [C] \{\delta\Delta\} R d\theta dx \quad (\text{III-27})$$

The triple matrix product  $[C]^T [\hat{K}^1] [C]$  is designated as [H] and is given in Table B-1 in Appendix B. The terms in Table B-1 are designated  $h_{i,j}$  where the i and j denote the row and column, respectively, in which the term is located in the matrix. The overall arrangement of the matrix is identical to that shown in Table III-1, and the element corner displacement vector  $\{\delta\Delta\}$  has been reorded accordingly. Only non-zero terms are given. The matrix is also symmetrical.

Prior to carrying out the indicated integration, an assumption must be made with regard to the character of the stress resultants  $N_1$ ,

$N_2$  and  $N_{12}$ . An assumption, consistent with the assumed linear displacement functions, is that these stress resultants are constants. With this assumption and after carrying out the integration of the right hand side of equation III-27, the non-zero terms of the initial stress matrix are as given in Table III-3. The arrangement of the terms in the  $[K_e^1]$  matrix is the same as indicated in Table III-1.

Attention is now turned to the third integral in equation III-15. Since the displacement functions stated in equations III-21, III-22 and III-23 are to be used in the development of the initial displacement stiffness matrix, the equation for the initial displacement stiffness matrix is obtained in exactly the same manner as was the equation for the initial stress matrix, equation III-27.

Hence:

$$[K_e^2] = \iint_{\text{area}} \{\delta\Delta\}^T [G]^T [\hat{K}^2] [G] \{\delta\Delta\} R d\theta dX \quad (\text{III-28})$$

The triple matrix area product  $[G]^T [\hat{K}^2] [G]$  is designated as  $[E]$  and is given in Table B-1 in Appendix B. The terms in Table B-2 are designated  $e_{i,j}$  where the  $i$  and  $j$  denote the row and column, respectively, in which the term is located in the matrix. Again, the overall arrangement of the matrix is the same as that shown in Table III-1. The ordering of the vector of element corner displacements is changed accordingly. Since the matrix is symmetrical, only the diagonal and lower triangular terms are given. Also, only nonzero terms are given.

Before the indicated integration can be carried out, an assumption must be made about the rotations  $\beta_1$  and  $\beta_2$ . An assumption that  $\beta_1$



and  $\beta_2$  are constants is compatible with the linear displacement functions assumed for  $w$ . The values of  $\beta_1$  and  $\beta_2$  for an element are the average rotations for that element. The equations used to compute  $\beta_1$  and  $\beta_2$  are given in Chapter IV. With this assumption, the non-zero terms of the initial displacement stiffness matrix, obtained from the term by the term integration of the right hand side of equation III-28, are given in Table III-4:

TABLE III-3 Elements of  $[K_e^1]$ 

$$k_{2,2}^1 = k_{8,8}^1 = k_{14,14}^1 = k_{20,20}^1 = \frac{N_2}{9} \left( \frac{ab}{R^2} \right)$$

$$k_{3,2}^1 = \frac{1}{6R} \left[ N_{12}b + N_2a \right]$$

$$k_{8,2}^1 = \frac{N_2}{18} \left( \frac{ab}{R^2} \right)$$

$$k_{9,2}^1 = \frac{-1}{6R} \left[ N_{12}b - \frac{N_2a}{2} \right]$$

$$k_{14,2}^1 = \frac{k_{2,2}^1}{4}$$

$$k_{15,2}^1 = -\frac{k_{3,2}^1}{2}$$

$$k_{20,2}^1 = k_{14,8}^1 = k_{20,14}^1 = \frac{k_{2,2}^1}{2}$$

$$k_{21,2}^1 = \frac{1}{6R} \left[ \frac{N_{12}}{2} b - N_2a \right]$$

$$k_{3,3}^1 = k_{15,15}^1 = \frac{N_1}{3} \left( \frac{b}{a} \right) + \frac{N_{12}}{2} + \frac{N_2}{3} \left( \frac{a}{b} \right)$$

$$k_{8,3}^1 = \frac{1}{6R} \left[ N_{12}b + \frac{N_2}{2} a \right]$$

$$k_{9,3}^1 = -\frac{N_1}{3} \left( \frac{b}{a} \right) + \frac{N_2}{6} \left( \frac{a}{b} \right)$$

$$k_{14,3}^1 = -k_{15,2}^1$$

$$k_{15,3}^1 = -\frac{N_1}{6} \left( \frac{b}{a} \right) - \frac{N_{12}}{2} - \frac{N_2}{6} \left( \frac{a}{b} \right)$$

$$k_{20,3}^1 = \frac{1}{6R} \left[ \frac{N_{12}}{2} b + N_2a \right]$$

$$k_{21,3}^1 = \frac{N_1}{6} \left( \frac{b}{a} \right) - \frac{N_2}{3} \left( \frac{a}{b} \right)$$

TABLE III-3 (Concluded)

$$k_{9,9}^1 = k_{21,21}^1 = \frac{N_1}{3} \left( \frac{b}{a} \right) - \frac{N_{12}}{2} + \frac{N_2}{3} \left( \frac{a}{b} \right)$$

$$k_{21,3}^1 = \frac{N_1}{6} \left( \frac{b}{a} \right) - \frac{N_2}{3} \left( \frac{a}{b} \right)$$

$$k_{9,8}^1 = -\frac{1}{6R} [N_{12}b - N_2a]$$

$$k_{15,8}^1 = -\frac{1}{6R} \left[ \frac{N_{12}}{2} b + N_2a \right]$$

$$k_{20,8}^1 = \frac{k_{2,2}^1}{4}$$

$$k_{21,8}^1 = \frac{1}{12R} [N_{12}b - N_2a]$$

$$k_{14,9}^1 = -k_{21,2}^1$$

$$k_{15,9}^1 = k_{21,3}^1$$

$$k_{20,9}^1 = \frac{k_{9,8}^1}{2}$$

$$k_{21,9}^1 = -\frac{N_1}{6} \left( \frac{b}{a} \right) + \frac{N_{12}}{2} - \frac{N_2}{6} \left( \frac{a}{b} \right)$$

$$k_{15,14}^1 = -k_{3,2}^1$$

$$k_{21,14}^1 = -k_{9,2}^1$$

$$k_{20,15}^1 = -\frac{1}{6R} \left[ N_{12}b + \frac{N_2}{2} a \right]$$

$$k_{21,15}^1 = -\frac{N_1}{3} \left( \frac{b}{a} \right) + \frac{N_2}{6} \left( \frac{a}{b} \right)$$

$$k_{21,20}^1 = -k_{3,2}^1$$

TABLE III-4 ELEMENTS OF  $[K_e^2]$ 

$$k_{2,1}^2 = -\frac{D_m}{6R} \left[ \frac{(1-\nu)}{2} a \beta_1 + \nu b \beta_2 \right]$$

$$k_{3,1}^2 = -D_m \left\{ \left[ \frac{(1-\nu)}{2} \left( \frac{a}{b} \right) + \left( \frac{b}{a} \right) \right] \frac{\beta_1}{3} - \frac{(1-\nu)}{8} \beta_2 \right\}$$

$$k_{8,1}^2 = -\frac{D_m}{6R} \left[ \frac{(1-\nu)}{4} a \beta_1 + \nu b \beta_2 \right]$$

$$k_{9,1}^2 = -D_m \left\{ \left[ \frac{(1-\nu)}{2} \left( \frac{a}{b} \right) - \left( \frac{b}{a} \right) \right] \frac{\beta_1}{3} + \frac{(1-3\nu)}{8} \beta_2 \right\}$$

$$k_{14,1}^2 = \frac{k_{2,1}^2}{2}$$

$$k_{15,1}^2 = D_m \left\{ \left[ \frac{(1-\nu)}{2} \left( \frac{a}{b} \right) + \left( \frac{b}{a} \right) \right] \frac{\beta_1}{6} + \frac{(1+\nu)}{8} \beta_2 \right\}$$

$$k_{20,1}^2 = -\frac{D_m}{12R} \left[ (1-\nu) a \beta_1 + \nu b \beta_2 \right]$$

$$k_{21,1}^2 = D_m \left\{ \left[ (1-\nu) \left( \frac{a}{b} \right) - \left( \frac{b}{a} \right) \right] \frac{\beta_1}{6} - \frac{(1-3\nu)}{8} \beta_2 \right\}$$

$$k_{2,2}^2 = -\frac{D_m}{3R} \left[ \frac{(1-\nu)}{2} b \beta_1 + a \beta_2 \right] + \frac{abD_m}{9R^2} \left[ \beta_2^2 + \frac{(1-\nu)}{2} \beta_1^2 \right]$$

$$k_{3,2}^2 = -D_m \frac{(1+\nu)}{8} \beta_1 - D_m \left[ \frac{(1-\nu)}{2} \left( \frac{b}{a} \right) + \left( \frac{a}{b} \right) \right] \frac{\beta_2}{3} + \frac{D_m}{6R} \left\{ \frac{b}{2} (1+\nu) \beta_1 \beta_2 \right. \\ \left. + a \left[ \beta_2^2 + \frac{(1-\nu)}{2} \beta_1^2 \right] \right\} + \frac{abD_m}{9R^2} \beta_2$$

$$k_{7,2}^2 = -\frac{D_m}{6R} \left[ \frac{(1-\nu)}{4} a \beta_1 - \nu b \beta_2 \right]$$

$$k_{8,2}^2 = -\frac{D_m a \beta_1}{6R} + \frac{abD_m}{18R^2} \left[ \beta_2^2 + \frac{(1-\nu)}{2} \beta_1^2 \right]$$

TABLE III-4 (Continued)

$$k_{9,2}^2 = -D_m \frac{(1-3\nu)}{8} \beta_1 + D_m \left[ (1-\nu) \left( \frac{b}{a} \right) + \left( \frac{a}{b} \right) \right] \frac{\beta_2}{6} - \frac{D_m}{12R} \left\{ b(1+\nu)\beta_1\beta_2 - a \left[ \beta_2^2 + \frac{(1-\nu)}{2} \beta_1^2 \right] \right\} + \frac{abD_m}{18R^2} \beta_2$$

$$k_{13,2}^2 = -\frac{k_{2,1}^2}{2}$$

$$k_{14,2}^2 = \frac{ab}{36R^2} D_m \left[ \beta_2^2 + \frac{(1-\nu)}{2} \beta_1^2 \right]$$

$$k_{15,2}^2 = \frac{(1+\nu)}{8} D_m \beta_1 + D_m \left[ \frac{(1-\nu)}{2} \left( \frac{b}{a} \right) + \left( \frac{a}{b} \right) \right] \frac{\beta_2}{6} - \frac{D_m}{12R} \left\{ \frac{b}{2} (1+\nu)\beta_1\beta_2 + a \left[ \beta_2^2 + \frac{(1-\nu)}{2} \beta_1^2 \right] \right\} + \frac{abD_m}{36R^2} \beta_2$$

$$k_{19,2}^2 = \frac{D_m}{12R} \left[ (1-\nu)a\beta_1 - \nu b\beta_2 \right]$$

$$k_{20,2}^2 = -\frac{(1-\nu)}{12R} D_m b\beta_1 + \frac{5D_m ab}{36R^2} \left[ \beta_2^2 + \frac{(1-\nu)}{2} \beta_1^2 \right]$$

$$k_{21,2}^2 = \frac{(1-3\nu)}{8} D_m \beta_1 - D_m \left[ \frac{(1-\nu)}{4} \left( \frac{b}{a} \right) - \left( \frac{a}{b} \right) \right] \frac{\beta_2}{3} + \frac{D_m}{6R} \left\{ \frac{(1+\nu)}{4} \beta_1\beta_2 b - a \left[ \beta_2^2 + \frac{(1-\nu)}{2} \beta_1^2 \right] \right\} + \frac{5D_m}{36R^2} ab\beta_2$$

$$k_{3,3}^2 = \frac{D_m}{3R} \left[ \nu b\beta_1 + a\beta_2 \right] + \frac{(1+\nu)}{4} D_m \beta_1\beta_2 + \frac{b}{3a} D_m \left[ \beta_1^2 + \frac{(1-\nu)}{2} \beta_2^2 \right] + \frac{a}{3b} D_m \left[ \beta_2^2 + \frac{(1-\nu)}{2} \beta_1^2 \right]$$

$$k_{7,3}^2 = -D_m \left[ \frac{(1-\nu)}{4} \left( \frac{a}{b} \right) - \left( \frac{b}{a} \right) \right] \frac{\beta_1}{3} - \frac{(1-3\nu)D_m}{8} \beta_2$$

$$k_{8,3}^2 = \frac{(1-3\nu)}{8} D_m \beta_1 + D_m \left[ (1-\nu) \left( \frac{b}{a} \right) - \left( \frac{a}{b} \right) \right] \frac{\beta_2}{6} + \frac{ab}{18R^2} D_m \beta_2 + \frac{D_m}{12R} \left\{ b(1+\nu)\beta_1\beta_2 + a \left[ \beta_2^2 + \frac{(1-\nu)}{2} \beta_1^2 \right] \right\}$$

TABLE III-4 (Continued)

$$k_{9,3}^2 = D_m \left\{ \frac{a\beta_2}{6R} - \frac{b}{3a} \left[ \beta_1^2 + \frac{(1-\nu)}{2} \beta_2^2 \right] + \frac{a}{6b} \left[ \beta_2^2 + \frac{(1-\nu)}{2} \beta_1^2 \right] \right\}$$

$$k_{13,3}^2 = k_{15,1}^2$$

$$k_{14,3}^2 = \frac{(1+\nu)}{8} D_m \beta_1 + D_m \left[ \frac{(1-\nu)}{2} \left( \frac{b}{a} \right) + \left( \frac{a}{b} \right) \right] \frac{\beta_2}{6} + \frac{abD_m}{36R^2} \beta_2 \right] \\ + \frac{D_m}{12R} \left\{ \frac{b}{2} (1+\nu) \beta_1 \beta_2 + a \left[ \beta_2^2 + \frac{(1-\nu)}{2} \beta_1^2 \right] \right\}$$

$$k_{15,3}^2 = -D_m \left\{ \frac{(1+\nu)}{4} \beta_1 \beta_2 + \frac{b}{6a} \left[ \beta_1^2 + \frac{(1-\nu)}{2} \beta_2^2 \right] + \frac{a}{6b} \left[ \beta_2^2 + \frac{(1-\nu)}{2} \beta_1^2 \right] \right\}$$

$$k_{19,3}^2 = D_m \left\{ \left[ (1-\nu) \left( \frac{a}{b} \right) - \left( \frac{b}{a} \right) \right] \frac{\beta_1}{6} + \frac{(1-3\nu)}{8} \beta_2 \right\}$$

$$k_{20,3}^2 = -D_m \left\{ \frac{(1-3\nu)}{8} \beta_1 + \left[ \frac{(1-\nu)}{4} \left( \frac{b}{a} \right) - \left( \frac{a}{b} \right) \right] \frac{\beta_2}{3} - \frac{5ab\beta_2}{36R^2} \right\} + \frac{D_m}{6R} \left\{ \frac{(1+\nu)}{4} b\beta_1\beta_2 \right. \\ \left. + a \left[ \beta_2^2 + \frac{(1-\nu)}{2} \beta_1^2 \right] \right\}$$

$$k_{21,3}^2 = \frac{D_m b \beta_1 \nu}{6R} + D_m \left\{ \frac{b}{6a} \left[ \beta_1^2 + \frac{(1-\nu)}{2} \beta_2^2 \right] - \frac{a}{3b} \left[ \beta_2^2 + \frac{(1-\nu)}{2} \beta_1^2 \right] \right\}$$

$$k_{8,7}^2 = -\frac{D_m}{6R} \left[ \frac{(1-\nu)}{2} a\beta_1 - \nu b\beta_2 \right]$$

$$k_{9,7}^2 = -D_m \left\{ \left[ \frac{(1-\nu)}{2} \left( \frac{a}{b} \right) + \left( \frac{b}{a} \right) \right] \frac{\beta_1}{3} - \frac{(1+\nu)}{8} \beta_2 \right\}$$

$$k_{14,7}^2 = -k_{19,2}^2$$

TABLE III-4 (Continued)

$$k_{15,7}^2 = k_{19,3}^2$$

$$k_{20,7}^2 = \frac{k_{8,7}^2}{2}$$

$$k_{21,7}^2 = D_m \left\{ \left[ \frac{1-\nu}{2} \left( \frac{a}{b} \right) + \left( \frac{b}{a} \right) \right] \frac{\beta_1}{6} - \frac{1+\nu}{8} \beta_2 \right\}$$

$$k_{8,8}^2 = \frac{D_m}{3R} \left[ \frac{(1-\nu)}{2} b\beta_1 - a\beta_2 \right] + \frac{ab}{9R^2} D_m \left[ \beta_2^2 + \frac{(1-\nu)}{2} \beta_1^2 \right]$$

$$k_{9,8}^2 = D_m \left\{ \frac{(1+\nu)}{8} \beta_1 - \left[ \frac{(1-\nu)}{2} \left( \frac{b}{a} \right) + \left( \frac{a}{b} \right) \right] \frac{\beta_2}{3} + \frac{ab}{9R^2} \beta_2 \right. \\ \left. - \frac{D_m}{6R} \left[ \frac{(1+\nu)}{2} b\beta_1\beta_2 - a \left[ \beta_2^2 + \frac{(1-\nu)}{2} \beta_1^2 \right] \right] \right\}$$

$$k_{13,8}^2 = -k_{20,1}^2$$

$$k_{14,8}^2 = \frac{(1-\nu)}{12R} D_m b\beta_1 + \frac{ab}{18R^2} D_m \left[ \beta_2^2 + \frac{(1-\nu)}{2} \beta_1^2 \right]$$

$$k_{15,8}^2 = -D_m \left\{ \frac{(1-3\nu)}{8} \beta_1 + \left[ \frac{(1-\nu)}{4} \left( \frac{b}{a} \right) - \left( \frac{a}{b} \right) \right] \frac{\beta_2}{2} - \frac{ab}{18R^2} \beta_2 \right. \\ \left. - \frac{D_m}{6R} \left[ \frac{(1+\nu)}{4} b\beta_1\beta_2 + a \left[ \beta_2^2 + \frac{(1-\nu)}{2} \beta_1^2 \right] \right] \right\}$$

$$k_{19,8}^2 = -\frac{k_{8,7}^2}{2}$$

$$k_{20,8}^2 = \frac{D_m ab}{36R^2} \left[ \beta_2^2 + \frac{1-\nu}{2} \beta_1^2 \right]$$

TABLE III-4 (Continued)

$$k_{21,8}^2 = -D_m \left\{ \frac{(1+\nu)}{8} \beta_1 - \left[ \frac{(1-\nu)}{2} \left( \frac{b}{a} \right) + \left( \frac{a}{b} \right) \right] \frac{\beta_2}{6} - \frac{ab\beta_2}{36R^2} \right\} \\ + \frac{D_m}{12R} \left\{ \frac{(1+\nu)}{2} b\beta_1\beta_2 - a \left[ \beta_2^2 + \frac{(1-\nu)}{2} \beta_1^2 \right] \right\}$$

$$k_{9,9}^2 = -\frac{D_m}{3R} \left[ vb\beta_1 - a\beta_2 \right] + D_m \left\{ \frac{(1+\nu)}{4} \beta_1\beta_2 + \frac{b}{3a} \left[ \beta_1^2 + \frac{(1-\nu)}{2} \beta_2^2 \right] \right. \\ \left. + \frac{a}{3b} \left[ \beta_2^2 + \frac{(1-\nu)}{2} \beta_1^2 \right] \right\}$$

$$k_{13,9}^2 = k_{21,1}^2$$

$$k_{14,9}^2 = D_m \left\{ \frac{(1-3\nu)}{8} \beta_1 - \left[ \frac{(1-\nu)}{4} \left( \frac{b}{a} \right) - \left( \frac{a}{b} \right) \right] \frac{\beta_2}{3} + \frac{ab\beta_2}{18R^2} \right\} - \frac{D_m}{6R} \left\{ \frac{(1+\nu)}{4} b\beta_1\beta_2 \right. \\ \left. - a \left[ \beta_2^2 + \frac{(1-\nu)}{2} \beta_1^2 \right] \right\}$$

$$k_{15,9}^2 = \frac{-D_m}{6R} vb\beta_1 + D_m \left\{ \frac{b}{6a} \left[ \beta_1^2 + \frac{(1-\nu)}{2} \beta_2^2 \right] - \frac{a}{3b} \left[ \beta_2^2 + \frac{(1-\nu)}{2} \beta_1^2 \right] \right\}$$

$$k_{19,9}^2 = k_{21,7}^2$$

$$k_{20,9}^2 = -D_m \left\{ \frac{(1+\nu)}{8} \beta_1 - \left[ \frac{(1-\nu)}{2} \left( \frac{b}{a} \right) + \left( \frac{a}{b} \right) \right] \frac{\beta_2}{6} - \frac{ab\beta_2}{36R^2} \right\} \\ - \frac{D_m}{12R} \left\{ \frac{(1+\nu)}{2} b\beta_1\beta_2 - a \left[ \beta_2^2 + \frac{(1-\nu)}{2} \beta_1^2 \right] \right\}$$

$$k_{21,9}^2 = D_m \left\{ \frac{(1+\nu)}{4} \beta_1\beta_2 - \frac{b}{6a} \left[ \beta_1^2 + \frac{(1-\nu)}{2} \beta_2^2 \right] - \frac{a}{6b} \left[ \beta_2^2 + \frac{(1-\nu)}{2} \beta_1^2 \right] \right\}$$



TABLE III-4 (Continued)

$$k_{14,13}^2 = -\frac{k_{14,1}^2}{2}$$

$$k_{15,13}^2 = k_{3,1}^2$$

$$k_{20,13}^2 = -k_{8,1}^2$$

$$k_{21,13}^2 = k_{9,1}^2$$

$$k_{14,14}^2 = \frac{D_m}{3R} \left[ \frac{(1-\nu)}{2} b\beta_1 + a\beta_2 \right] + \frac{abD_m}{9R^2} \left[ \beta_2^2 + \frac{(1-\nu)}{2} \beta_1^2 \right]$$

$$k_{15,14}^2 = -D_m \left\{ \frac{(1+\nu)}{8} \beta_1 + \left[ \frac{(1-\nu)}{2} \left( \frac{b}{a} \right) + \left( \frac{a}{b} \right) \right] \frac{\beta_2}{3} - \frac{ab\beta_2}{9R^2} \right\} \\ - \frac{D_m}{6R} \left\{ \frac{(1+\nu)}{2} b\beta_1\beta_2 + a \left[ \beta_2^2 + \frac{(1-\nu)}{2} \beta_1^2 \right] \right\}$$

$$k_{19,14}^2 = -k_{7,2}^2$$

$$k_{20,14}^2 = \frac{D_m}{6R} a\beta_2 + \frac{abD_m}{18R^2} \left[ \beta_2^2 + \frac{(1-\nu)}{2} \beta_1^2 \right]$$

$$k_{21,14}^2 = -D_m \left\{ \frac{(1-3\nu)}{8} \beta_1 - \left[ (1-\nu) \left( \frac{b}{a} \right) - \frac{a}{b} \right] \frac{\beta_2}{6} - \frac{ab\beta_2}{18R^2} \right\} \\ + \frac{D_m}{12R} \left\{ (1-\nu) b\beta_1\beta_2 - a \left[ \beta_2^2 + \frac{(1-\nu)}{2} \beta_1^2 \right] \right\}$$

$$k_{15,15}^2 = -\frac{D_m}{3R} [b\beta_1 + a\beta_2] + D_m \left\{ \frac{(1+\nu)}{4} \beta_1\beta_2 + \frac{b}{3a} \left[ \beta_1^2 + \frac{(1-\nu)}{2} \beta_2^2 \right] \right\}$$

TABLE III-4 (Concluded)

$$+ \frac{a}{3b} \left[ \beta_2^2 + \frac{(1-\nu)}{2} \beta_1^2 \right] \Big\}$$

$$k_{19,15}^2 = k_{7,3}^2$$

$$k_{20,15}^2 = D_m \left\{ \frac{(1-3\nu)}{8} \beta_1 + \left[ (1-\nu) \left( \frac{b}{a} \right) - \left( \frac{a}{b} \right) \right] \frac{\beta_2}{6} + \frac{ab\beta_2}{18R^2} \right\} \\ - \frac{D_m}{12R} \left\{ (1+\nu) b\beta_1\beta_2 + a \left[ \beta_2^2 + \frac{(1-\nu)}{2} \beta_1^2 \right] \right\}$$

$$k_{21,15}^2 = -a \frac{D_m}{6R} \beta_2 - D_m \left\{ \frac{b}{3a} \left[ \beta_1^2 + \frac{(1-\nu)}{2} \beta_2^2 \right] + \frac{a}{6b} \left[ \beta_2^2 + \frac{(1-\nu)}{2} \beta_1^2 \right] \right\}$$

$$k_{20,19}^2 = -k_{8,7}^2$$

$$k_{21,19}^2 = k_{9,7}^2$$

$$k_{20,20}^2 = - \frac{D_m}{3R} \left[ \frac{(1-\nu)}{2} b\beta_1 - a\beta_2 \right] + \frac{abD_m}{9R^2} \left[ \beta_2^2 + \frac{(1-\nu)}{2} \beta_1^2 \right]$$

$$k_{21,20}^2 = k_{9,8}^2$$

$$k_{21,21}^2 = \frac{D_m}{3R} \left[ vb\beta_1 - a\beta_2 \right] - D_m \left\{ \frac{(1+\nu)}{4} \beta_1\beta_2 - \frac{b}{3a} \left[ \beta_1^2 + \frac{(1-\nu)}{2} \beta_2^2 \right] \right. \\ \left. - \frac{a}{3b} \left[ \beta_2^2 + \frac{(1-\nu)}{2} \beta_1^2 \right] \right\}$$

## CHAPTER IV.

METHOD OF COMPUTATION

In this chapter, the procedures required to solve for the buckling behavior of a complete cylindrical shell structure will be presented. Consider the idealization of a complete shell structure to be formed entirely of the cylindrical elements developed in Chapter III. In order to assess the buckling behavior of the structure, the second variation of the strain energy of the structure is formulated in terms of the element stiffness, initial stress and initial displacement stiffness matrices developed in Chapter III. The concept of combining element stiffness matrices to produce a "master stiffness" matrix for the complete structure is well documented (references 27 and 32).

The second variation of the potential energy for the complete structure with the boundary conditions applied has the form:

$$\delta^2\pi = \{\delta\Delta\}^T \left[ [\bar{K}^0] + [\bar{K}^1] + [\bar{K}^2] \right] \{\delta\Delta\} \quad (\text{IV-1})$$

where  $[\bar{K}^0]$ ,  $[\bar{K}^1]$  and  $[\bar{K}^2]$  are the reduced master stiffness, initial stress and initial displacement stiffness matrices respectively.

Applying the stability criterion stated by equation II-2 to equation IV-1, the requirement for neutral stability of the complete structure is:

$$\{\delta\Delta\}^T \left[ [\bar{K}^0] + [\bar{K}^1] + [\bar{K}^2] \right] \{\delta\Delta\} = 0 \quad (\text{IV-2})$$

In the solution of equation IV-2, consideration will be restricted to

a linear elastic instability analysis. As used herein, linear elastic instability analysis is defined as the calculation of the condition for the bifurcation of equilibrium without the need for an iterative determination of the internal loads or deformations. Hence, the magnitude of the initial stress stiffness matrix corresponding to the application of the critical load is proportional to its magnitude corresponding to the application of smaller, but otherwise arbitrary, load. More simply stated,

$$[\bar{K}^1] \Big|_{N_{cr}} = \lambda [\bar{K}^1] \Big|_N ; N < N_{cr}$$

where the engenvalue,  $\lambda$ , is

$$\lambda = \frac{N_{cr}}{N}$$

in which  $N_{cr}$  is the load for bifurcation of equilibrium and  $N$  is an arbitrary initial load.

In Chapter II, the reason for neglecting the squares of the rotation in the  $[K_e^2]$  matrix for the beam column was discussed. The same line of reasoning, is applicable to the rotations,  $\beta_1$  and  $\beta_2$ , of the cylindrical shell element. Consequently, the squares of rotations in the  $[\bar{K}^2]$  matrix will be neglected. The initial displacement stiffness matrix for a linear elastic stability analysis is

$$[\bar{K}^2] \Big|_{N_{cr}} = \lambda [\bar{K}^2] \Big|_N$$

The linearized, nontrivial solution of equation IV-2 is

$$\det | [\bar{K}^0] + \lambda \left[ [\bar{K}^1] + [\bar{K}^2] \right] | = 0 \quad (\text{IV-3})$$

For computational purposes, the above equation is more conveniently stated as

$$\det \left| \frac{1}{\lambda} [I] + [\bar{K}^0]^{-1} \left[ [\bar{K}^1] + [\bar{K}^2] \right] \right| = 0 \quad (\text{IV-4})$$

where [I] is the identity matrix.

The major steps involved in the formulation and solution of equation IV-4 are:

1. From basic elemental data, compute the element stiffness matrices and construct the master stiffness matrix,  $[K^0]$ , for the structure.
2. Apply the appropriate boundary conditions to  $[K^0]$  to form the reduced master stiffness matrix,  $[\bar{K}^0]$ .
3. Multiply an arbitrary initial loading by the inverse of  $[\bar{K}^0]$  to determine the initial displacements,  $\{\Delta\}$ .
4. Compute the membrane stress resultants,  $N_1$ ,  $N_2$  and  $N_{12}$  for each element using

$$\{N\} = [S_e] \{\Delta_e\}$$

where  $[S_e]$  is the "element stress matrix" which is discussed in detail and shown in Tables III-7, III-8 and III-9 of reference 25.  $\{\Delta_e\}$  are the nodal displacements for the element under consideration.

5. Compute the "average" rotations about the X and  $\theta$  axes,  $\beta_2$  and  $\beta_1$  respectively, from

$$\bar{\beta}_1 = \frac{1}{2a} [w_1 - w_2 + w_4 - w_3]$$

and

$$\bar{\beta}_2 = \frac{1}{2b} [w_1 - w_4 + w_2 - w_3] + \frac{1}{4R} [v_1 + v_2 + v_3 + v_4]$$

6. Using the results of steps 4 and 5, construct initial stress and initial displacement stiffness matrices for each element and construct the master initial stress and master initial displacement stiffness matrices,  $[K^1]$  and  $[K^2]$ , respectively.

7. Apply the same boundary conditions to  $[K^1]$  and  $[K^2]$  as were applied to  $[K^0]$  to determine the reduced master initial stress and initial displacement stiffness matrices,  $[\bar{K}^1]$  and  $[\bar{K}^2]$ , respectively.

8. Compute

$$[\bar{K}^0]^{-1} \left[ [\bar{K}^1] + [\bar{K}^2] \right]$$

and compute the eigenvalues of equation IV-4.

A digital computer program has been written to accomplish the eight steps set out above. The program is coded in Fortran IV language and has been used on the CDC 6600 digital computer at the NASA Langley Research Center. A listing of this computer program is given in Appendix C. The reading of input data; the calculation of element stiffness, stress, initial stress and initial displacement stiffness matrices; the formulation of master and reduced stiffness, initial stress and initial displacement stiffness matrices; and the printing of output were all coded directly. Library routines (ref. 33) were used for matrix multiplication, inversion and eigenvalue determination.

A concise flow chart of the program is shown in Figure IV-1. The general flow of the program follows the previously discussed eight solution steps. The subroutine used for the inversion of  $[\bar{K}^0]$  uses Jordan's method (reference 34) to reduce  $[\bar{K}^0]$  to the identity matrix [I] through a succession of elementary transformations. When these transformations are applied simultaneously to [I] and the load vector, the results are  $[\bar{K}^0]^{-1}$  and the displacement vector. The subroutine REIG of reference 33 finds the eigenvalues of a real, square matrix. The original matrix which, in this case, is  $[\bar{K}^0]^{-1}[\bar{K}^1] + [\bar{K}^2]$  is transformed to upper Hessenberg form. The eigenvalues are then found using the QR transform of J. G. F. Francis (reference 35).

Because of the vast amount of storage required to solve a problem of practical interest, an overlay procedure was used. In the first overlay, the inverted stiffness matrix; the reduced master initial stress stiffness matrix; and the reduced master initial displacement stiffness matrix are determined. In the second overlay,  $[\bar{K}^1]$  and  $[\bar{K}^2]$  are added. The resulting matrix is premultiplied by  $[\bar{K}^0]^{-1}$ . The highest eigenvalue is then determined for the resulting matrix. Each overlay uses 300,000 octal storage locations. The computing time, of course, varies with the number of degrees of freedom used. A problem having about 250 degrees of freedom requires about five minutes of computing time.

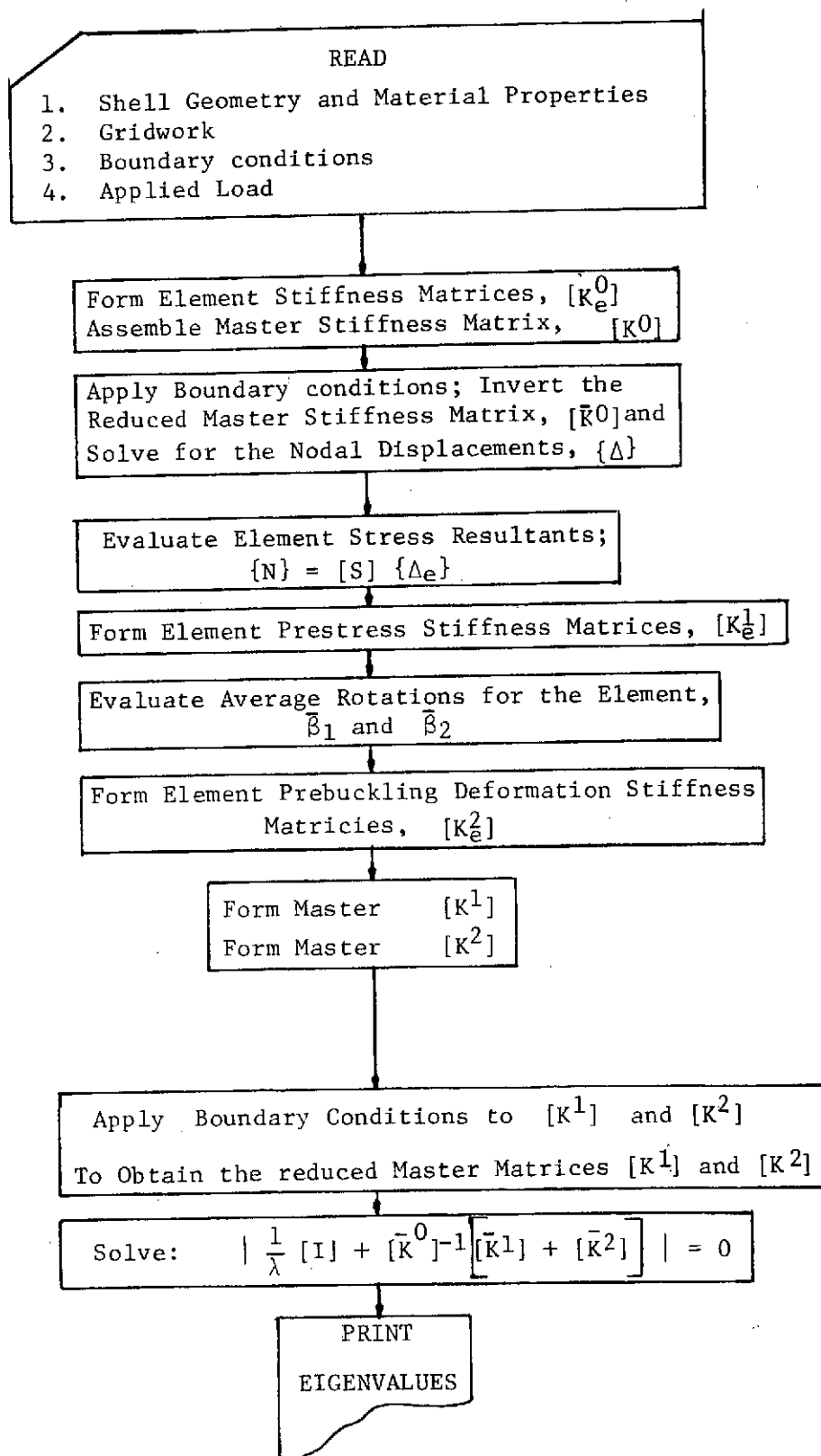

Figure IV.-1 Elastic instability program flow chart.



## CHAPTER V.

APPLICATIONS OF THE COMPUTER PROGRAM

The procedures described in Chapter II and the finite element developed in Chapter III were applied to the stability analysis of several types of structures by means of the computer program outlined in Chapter IV. The results of these analyses are delineated in this chapter. In addition, investigations pertaining to the influence of the initial displacement stiffness matrix and the importance of the non-linear terms in that matrix are reported. The types of structures considered were: the beam-column, the arch, the flat plate, and the curved panel with and without a cutout. The beam-column, flat plate, arch and curved panel without a cutout were studied for the purpose of establishing the accuracy of the procedure and the finite element. Since no information is available on the buckling of curved panels with cutouts, the accuracy of those results can only be inferred from the accuracy of the solutions obtained for the other types of structures.

An Euler column with both ends pin-ended was analyzed using the finite element developed herein. The exact solution to this problem is (reference 12):

$$P_{cr} = \frac{\pi^2 EI}{L^2} \quad (V-1)$$

The column was modeled using plate elements having a width and thickness of 1.0 in., thus giving the proper area moment of inertia for the column shown in Figure V-1. In this figure, the improvement in the accuracy of

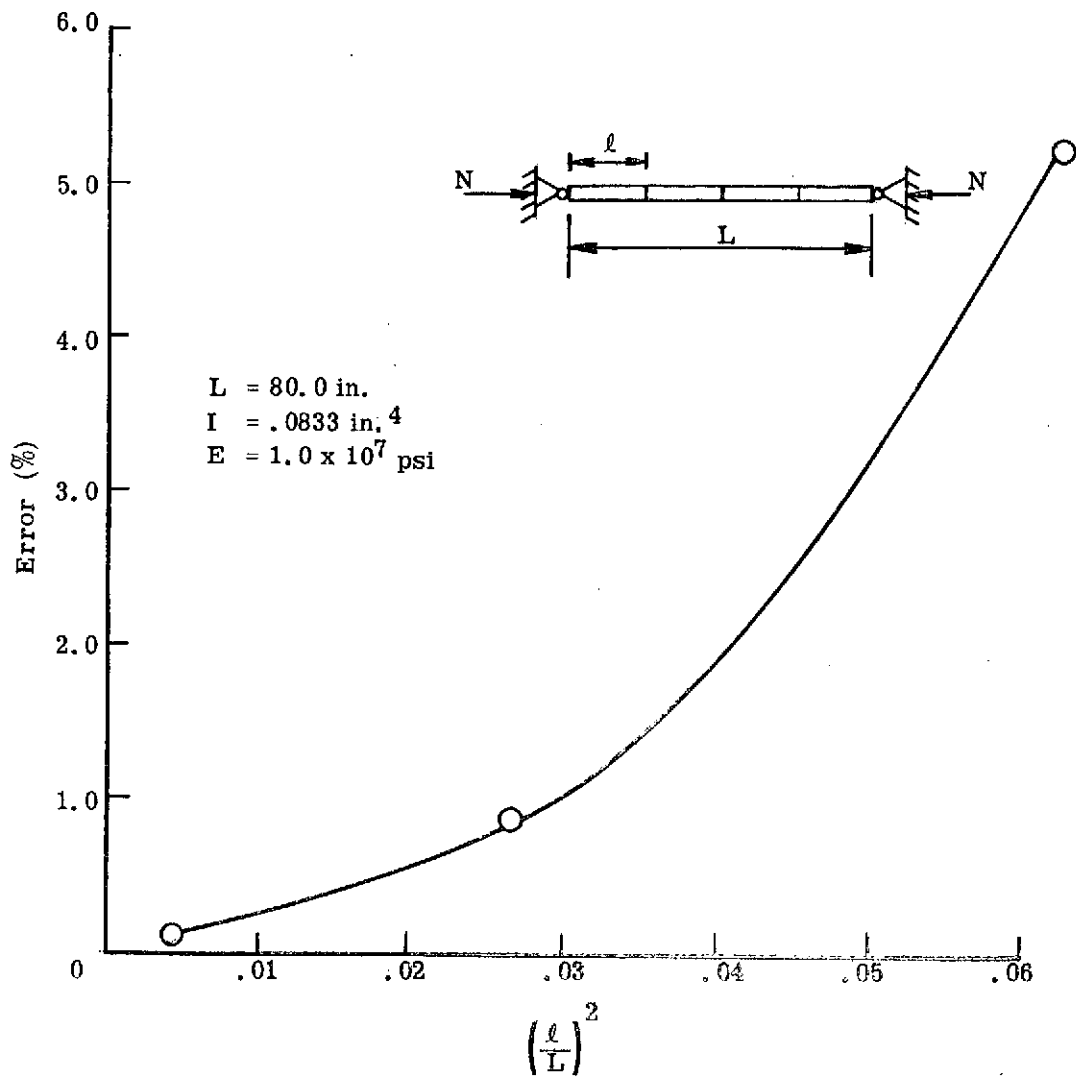

Figure V. -1 Euler column buckling vs. element size.

the solution is shown as a function of the square of the ratio of the finite element length ( $\ell$ ) to the total length of the column ( $L$ ). The percent error for an  $\left(\frac{\ell}{L}\right)^2$  of 0.0625 is in agreement with the solution obtained by H. C. Martin in reference 6 for the same degree of refinement.

The present finite element was applied to the solution for the buckling of a square, simply supported flat plate. As indicated in Figure V-2, the plate was loaded uniaxially with a uniform line load. By utilizing symmetry, it was possible to consider only one quadrant of the plate. The plate was modeled using square elements of length and width,  $\ell$ . 4, 9, 16 and 25 elements per quadrant were used. The influence of the mesh size on the solution accuracy is presented in Figure V-2. As can be seen in that figure, the accuracy of the solution converges rapidly to the closed form solution which is (ref. 12):

$$N_{cr} = \frac{4\pi^2 E h^3}{12(1-\nu^2)L^2} \quad (V-2)$$

Also plotted on Figure V-2 are the results obtained by Kapur and Hartz in reference 9. Both the stiffness matrix and initial stress stiffness matrix of the Kapur and Hartz finite element were derived using the fourth order displacement function for a thin plate in bending which was first presented by Melosh (reference 31). The advantage of using the higher order displacement function is seen in Figure V-2 to diminish as the mesh size decreases. The results indicate that both solutions have errors of order  $\left(\frac{\ell}{L}\right)^2$ . Since all prebuckling displacements are in the plane of the plate, the initial displacement stiffness matrix is

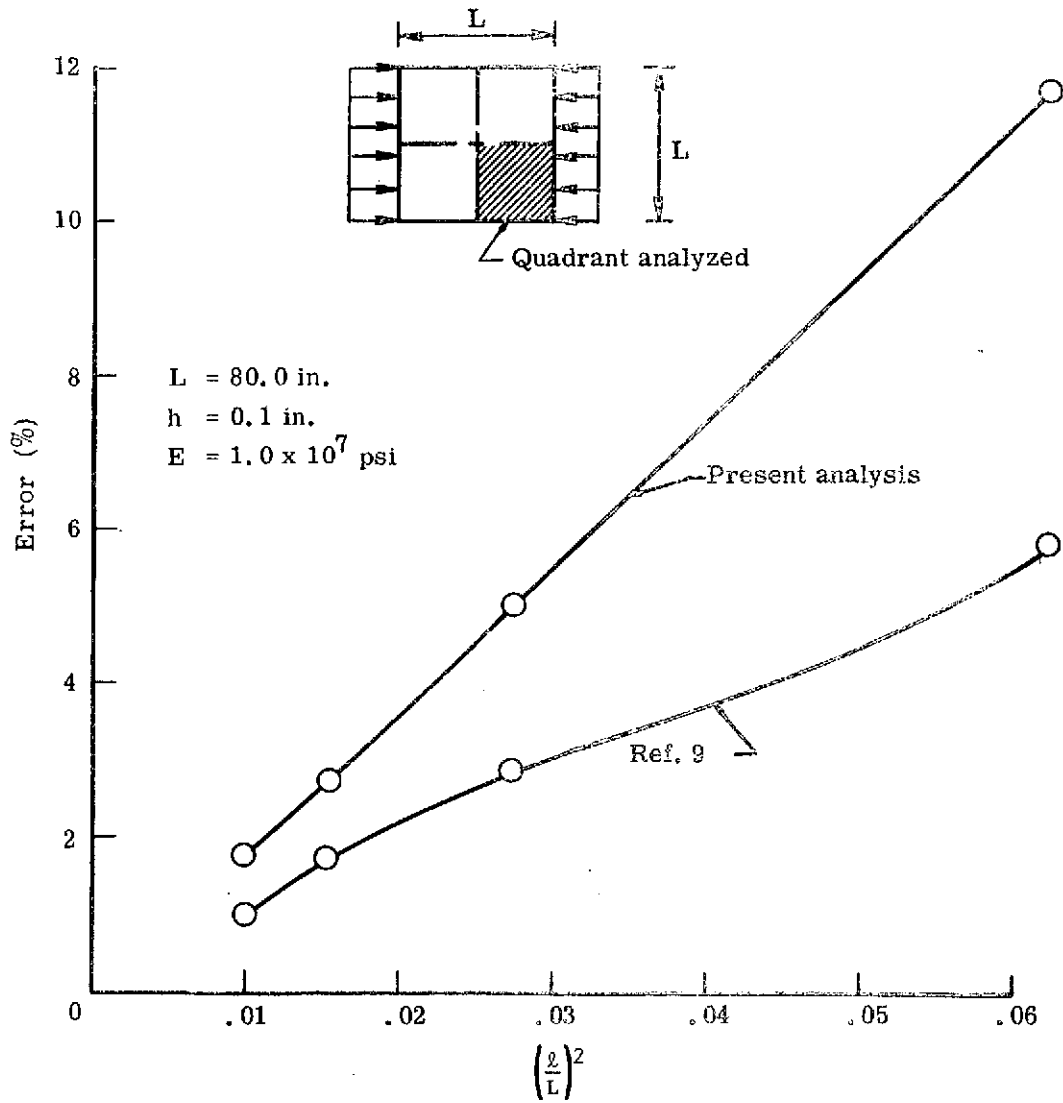

Figure V-2 Buckling of a simply supported flat plate vs. grid size

identically zero and hence plays no role in the solution of the flat plate buckling problem.

The computer program of Chapter IV was applied to the simply supported arch depicted in Figure V-3. The solution to the arch brings into play terms containing the element curvature as well as the initial displacement stiffness matrix. The exact solution for the buckling of a simply supported thin shell arch subjected to a uniform line load is given in references 12 and 36 as:

$$q_{cr} = \frac{Eh^2}{12(1-\nu^2)} \left[ \frac{4\pi^2}{\alpha^2} - 1 \right] \quad (IX-3)$$

For the arch shown in Figure V-3,  $q_{cr} = 275$  lb./in. The line load required to buckle the arch was computed to be 273 lb./in. using 12 of the present finite elements to represent the arch.

Cylindrical panels of varying curvature were modeled using the present finite element and the buckling load was computed. The panels considered had equal dimensions in the circumferential and longitudinal directions. The panels were simply supported along all four edges and a uniform compressive line load was applied in the axial direction. The well known cylindrical shell curvature parameter,  $Z$ , was varied between 1.0 and 10.0 by varying the radius of curvature,  $R$ .

Classical solutions (references 12, 15 and 37) for the buckling of curved panels in the curvature range considered predict a single half sine wave buckle in both meridional and circumferential directions. Since only one quadrant of the panels was modeled, it was necessary to establish that the lowest buckling load did indeed correspond to a single

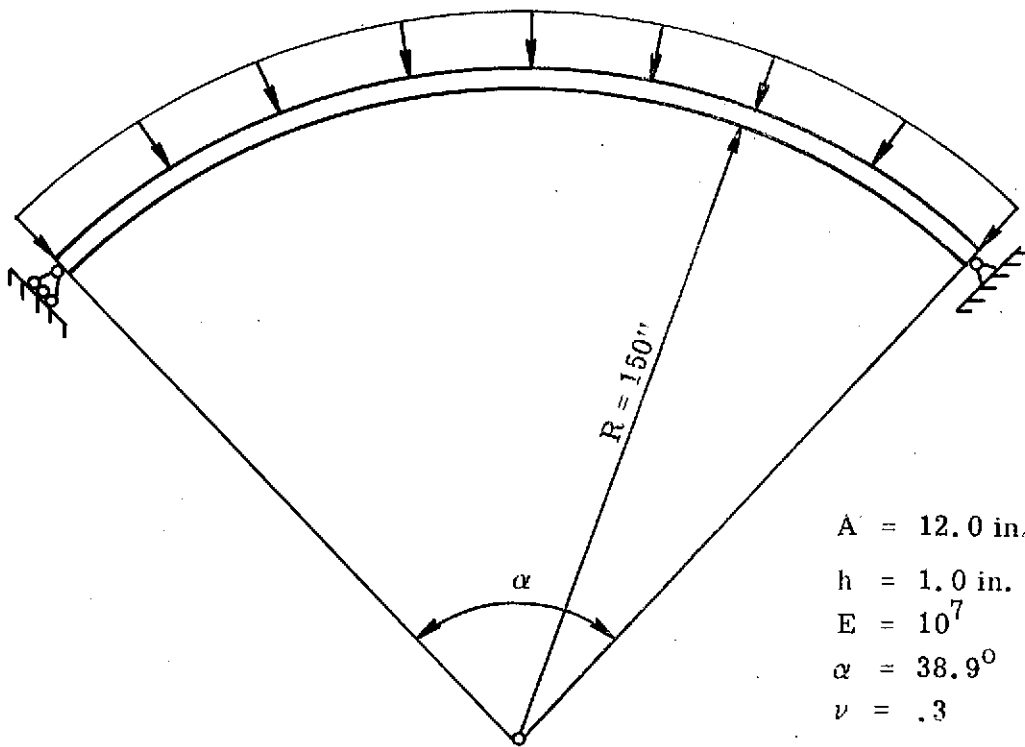

Figure V. -3 Simply supported arch with a uniform load.

half sine wave. This was accomplished by considering two sets of boundary conditions for the interior edges of the panel quadrant analyzed. Both sets of boundary conditions assumed a single half sine wave in the circumferential direction but one set assumed symmetry about the midline in the longitudinal direction and the other set assumed asymmetry. In each case, 25 elements were used to model the quadrant. Table V-1 gives the results of these analyses. The symmetric solutions give the lower buckling load in each case, hence, the finite element solution produces a buckling mode shape which is compatible with classical solutions.

Z	$K_x$	
	SYMMETRICAL SOLUTION	ASYMMETRICAL SOLUTION
0	4.06	6.52
1	4.08	6.53
5	4.33	6.66
10	5.08	7.02

TABLE V-1 BUCKLING COEFFICIENT FOR CURVED PANELS

As is established by Rehfield in reference 15, boundary conditions play an important role in the buckling of curved panels in the curvature range under consideration. The classical solution of references 12 and 37 for curved panels with simply supported edges involve boundary conditions for the inplane displacements,  $u$  and  $v$ , which are incompatible with the present analysis. Specifically, during buckling,  $u$  is assumed to be zero along the straight edges of the panel and  $v$  is assumed to be zero along the curved edges. In reference 15, the solution to the buckling of a curved panel with boundary conditions which permit inplane boundary displacements which are parallel to the simple supports is

presented. It is these results which are used as the basis of comparison. Figure V-4 shows the convergence of the present analysis to the classical solutions of reference 15 as the number of elements is increased. The edges of the panels are simply supported. Panels with curvature parameters,  $Z$ , of 1, 5 and 10 were investigated. In each case, the answer converges to the classical solution rapidly as the number of elements used is increased above nine per quadrant.

Figure V-5 illustrates the geometry of the simply supported curved panel with a cutout which was analyzed using the present finite element. The circumferential and axial lengths of the panel are equal. The cutout is such that its circumferential and axial lengths are also equal. Panels having curvature parameters of  $Z = 0, 1, 5$  and 10 were considered. Cutout sizes having ratios of cutout length,  $a$ , to panel length,  $L$ , of .1, .25 and .5 were investigated for each panel curvature parameter value. In each case 21 elements were used to represent the quadrant analyzed. Since the stress distribution and deformations of the panel due to the initial load are the parameters involved in the initial stress and the initial displacement stiffness matrices, respectively, it is instructive to first consider the stresses and deformations which result from the application of a unit axial line load to the panel shown in Figure V-5.

Shown in Figure V-6 are stress distributions between the edge of the panel and the edge of the cutout along the  $\theta$  axis (i.e., at  $X = 0$ ). This is the line of maximum stress concentration. The value of the curvature



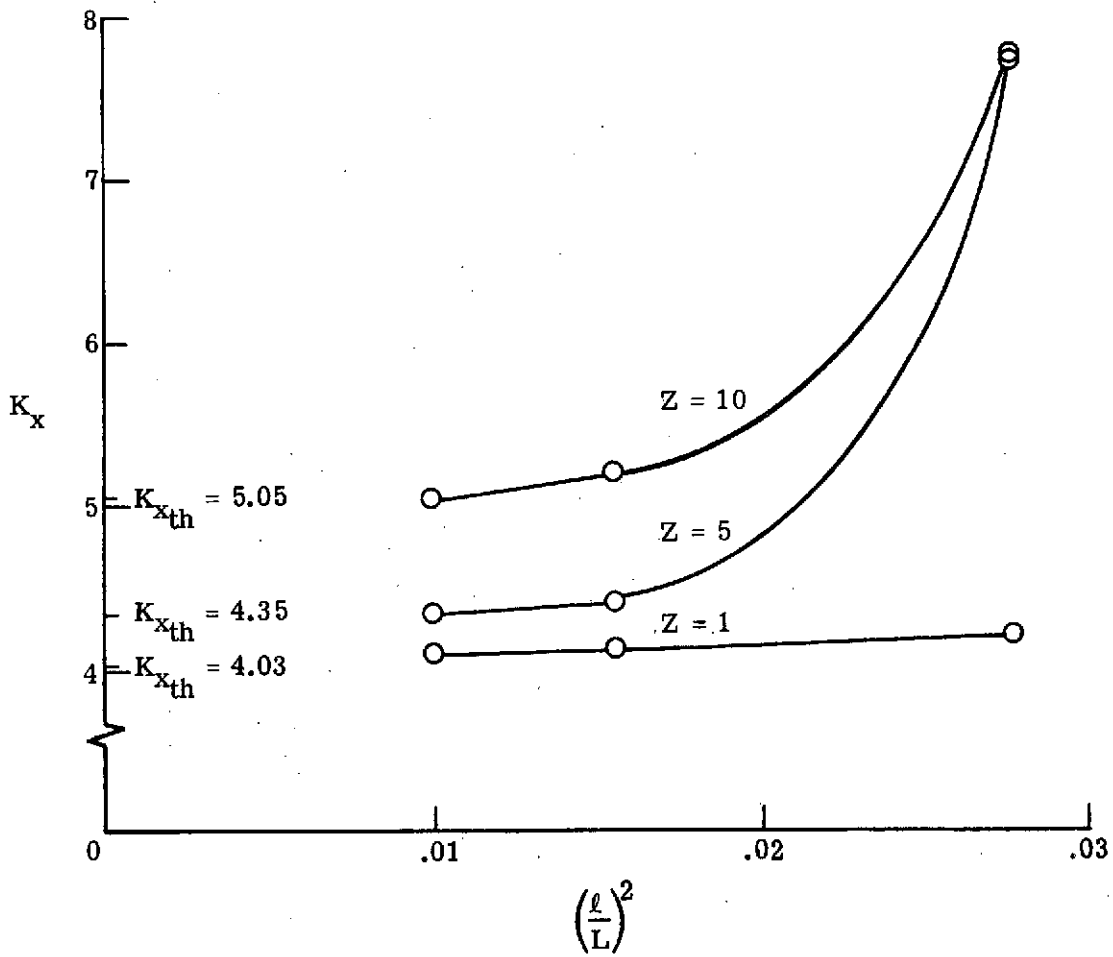
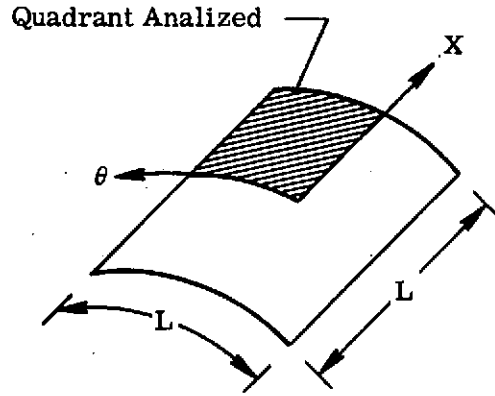

Figure V-4. - Buckling of simply supported curved panels vs. grid size.

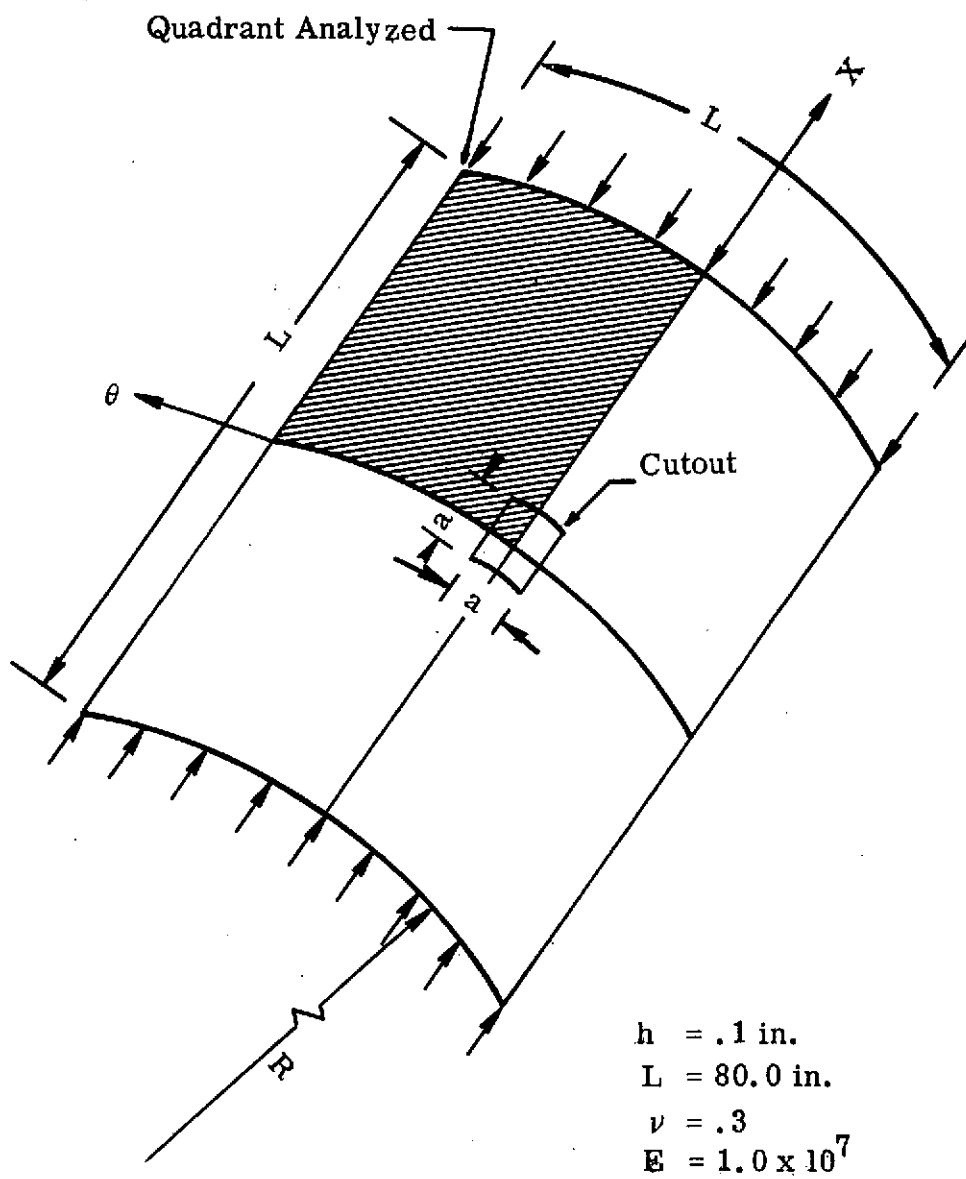

Figure V-5. Geometry of the curved panel with a cutout.

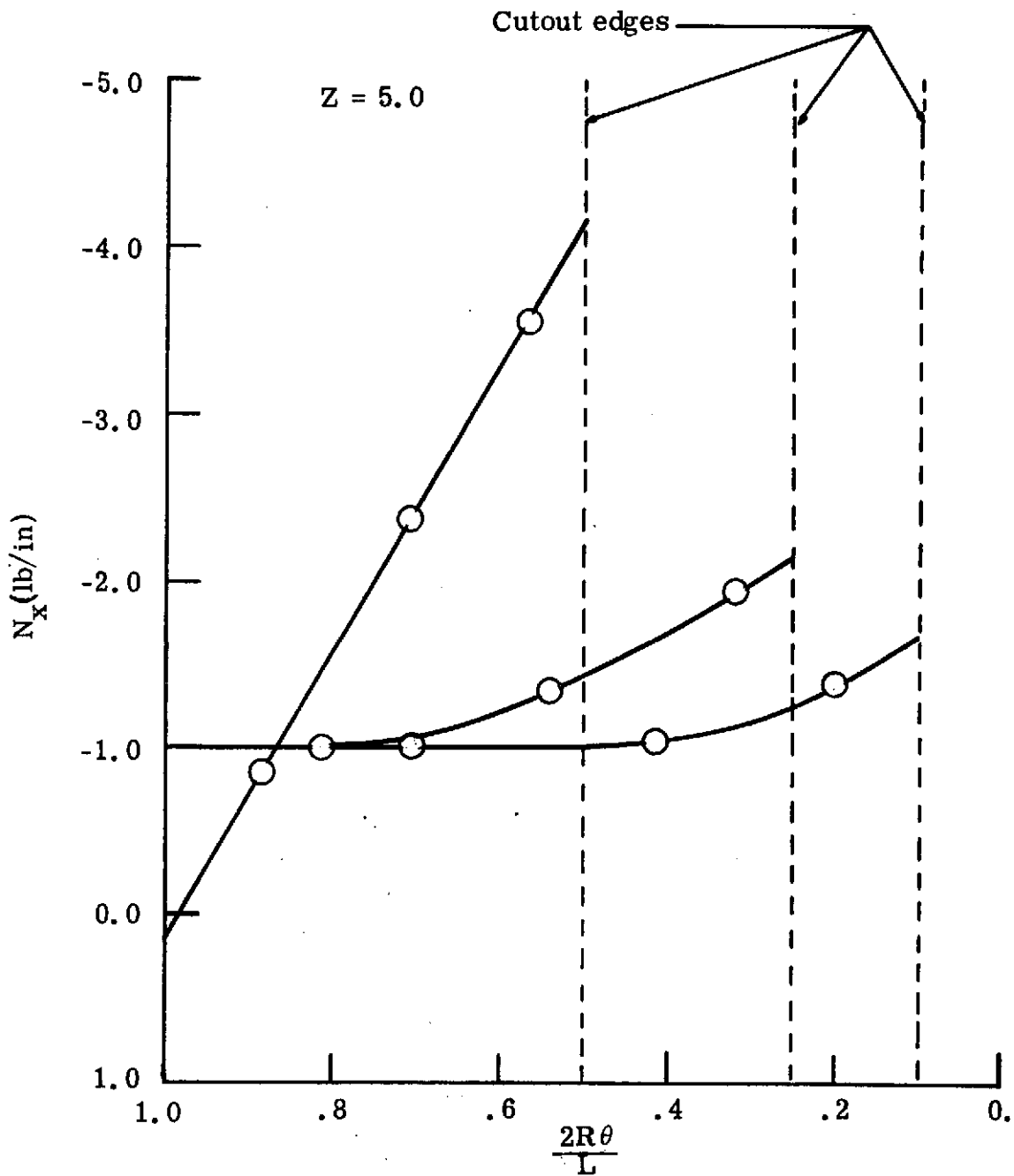

Figure V-6. Stress distribution along  $X = 0$  due to a uniform axial load of  $-1.0$  lb./in.

parameter associated with the stress distributions in Figure V-6 is 5. However, the plots shown in Figure V-6 are representative of values of  $Z$  from 1 to 10. The change in the stress distribution as a function of curvature, for the range studied, is negligible. As indicated in Figure V-6, the influence of the cutout on the stress field is maximum at the edge of the cutout and diminishes sharply at points near the simply supported edge. The stress distribution shown in Figure V-6 for the case of  $\frac{a}{L} = .1$  and  $.25$  are in good agreement with the results given by Savin (ref. 40) for an infinite flat plate with a square cutout. In reference 41, Savin has shown that the stress distribution is not greatly influenced by curvature for the range of  $Z$  considered herein.

Figures V-7, V-8 and V-9 show the deflections,  $w$ , normal to the middle surface along the  $x = 0$  axis which result from a unit axial line load applied to a simply supported curved panel with a cutout. Figure V-7 presents the results for the smallest cutout considered,  $a/L = .1$ . The influence of the cutout on the deflections markedly increase as the curvature of the panel increases. This same trend is very much in evidence in Figures V-8 and V-9 which show the deformations computed for the case of cutout sizes of an  $a/L = .25$  and  $a/L = .5$  respectively. Thus, while the stress distribution was found to be insensitive to curvature changes, the displacements normal to the panel middle surface are not. In addition, Figures V-7, V-8 and V-9 show the normal deflection at the edge of the cutout increases sharply as the size of the cutout increases.

Figures V-10, V-11, V-12 and V-13 illustrate the reduction in the buckling parameter  $K_x$  as a function of the cutout size for panels with

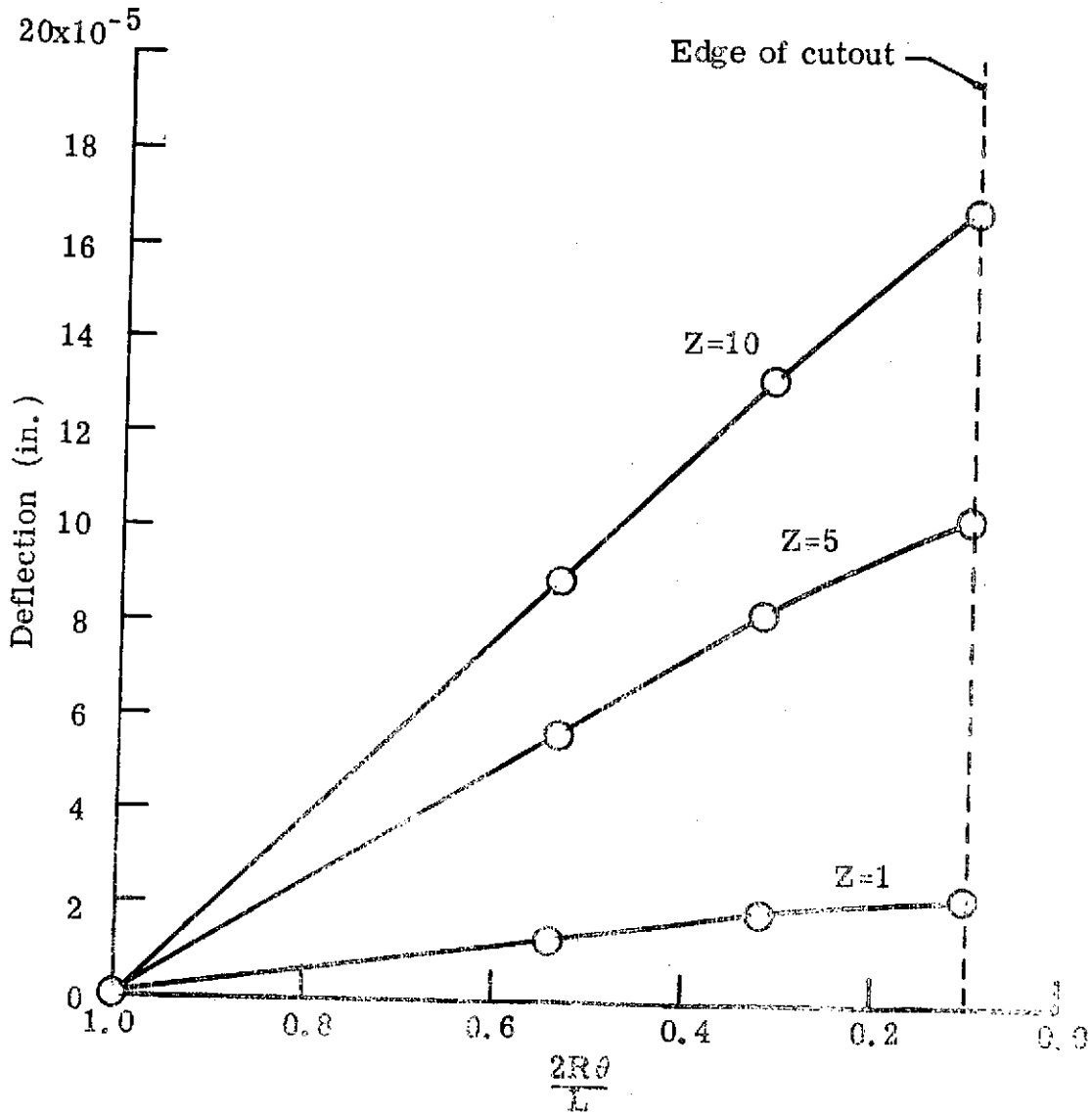

Figure V-7. - Normal deflection along  $X=0$  due to a uniform axial load of  $-1.0$  lb./in.

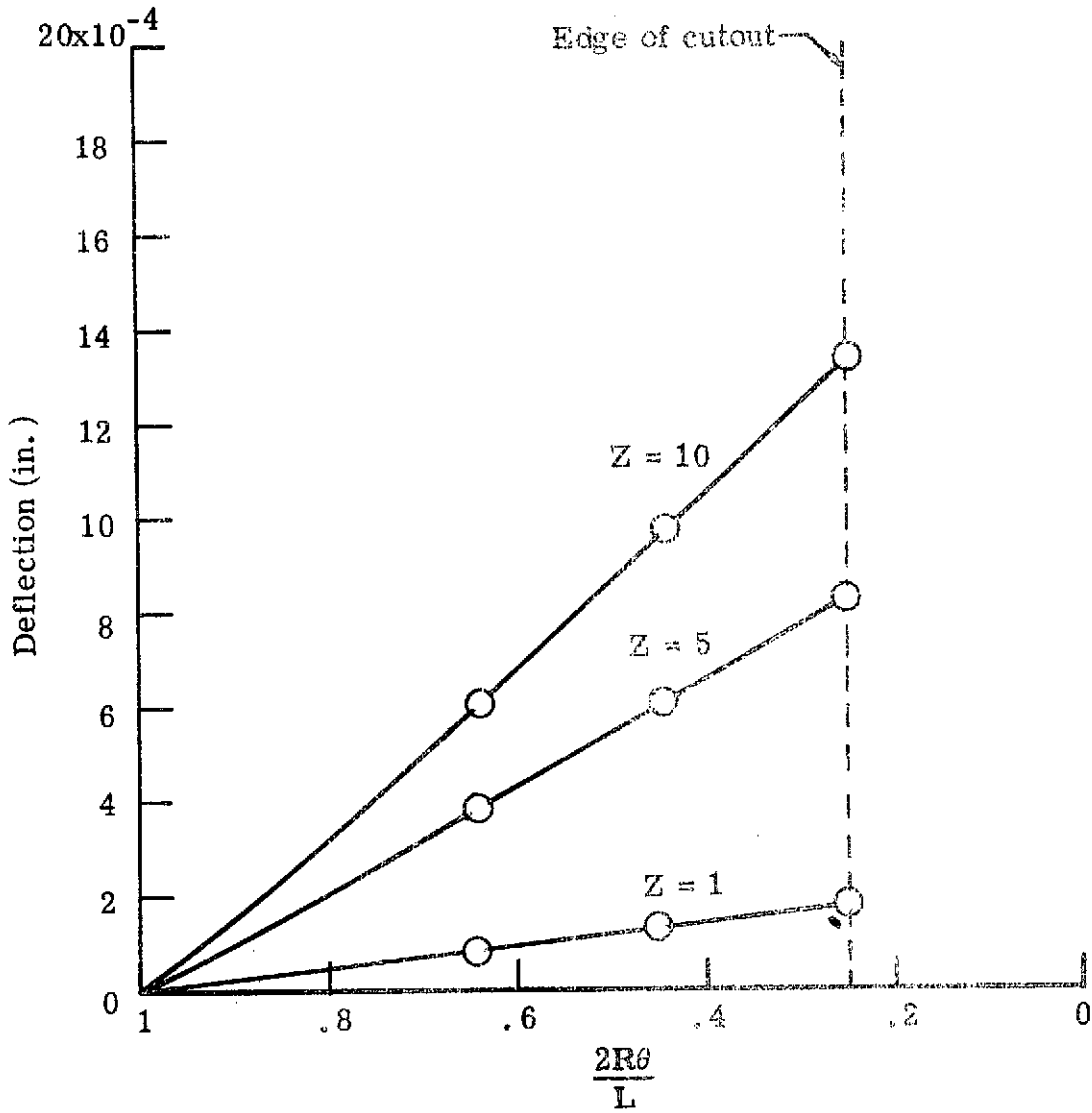

Figure V-8 Normal deflection along  $X=0$  due to a uniform axial load of  $-1.0 \text{ lb./in.}$

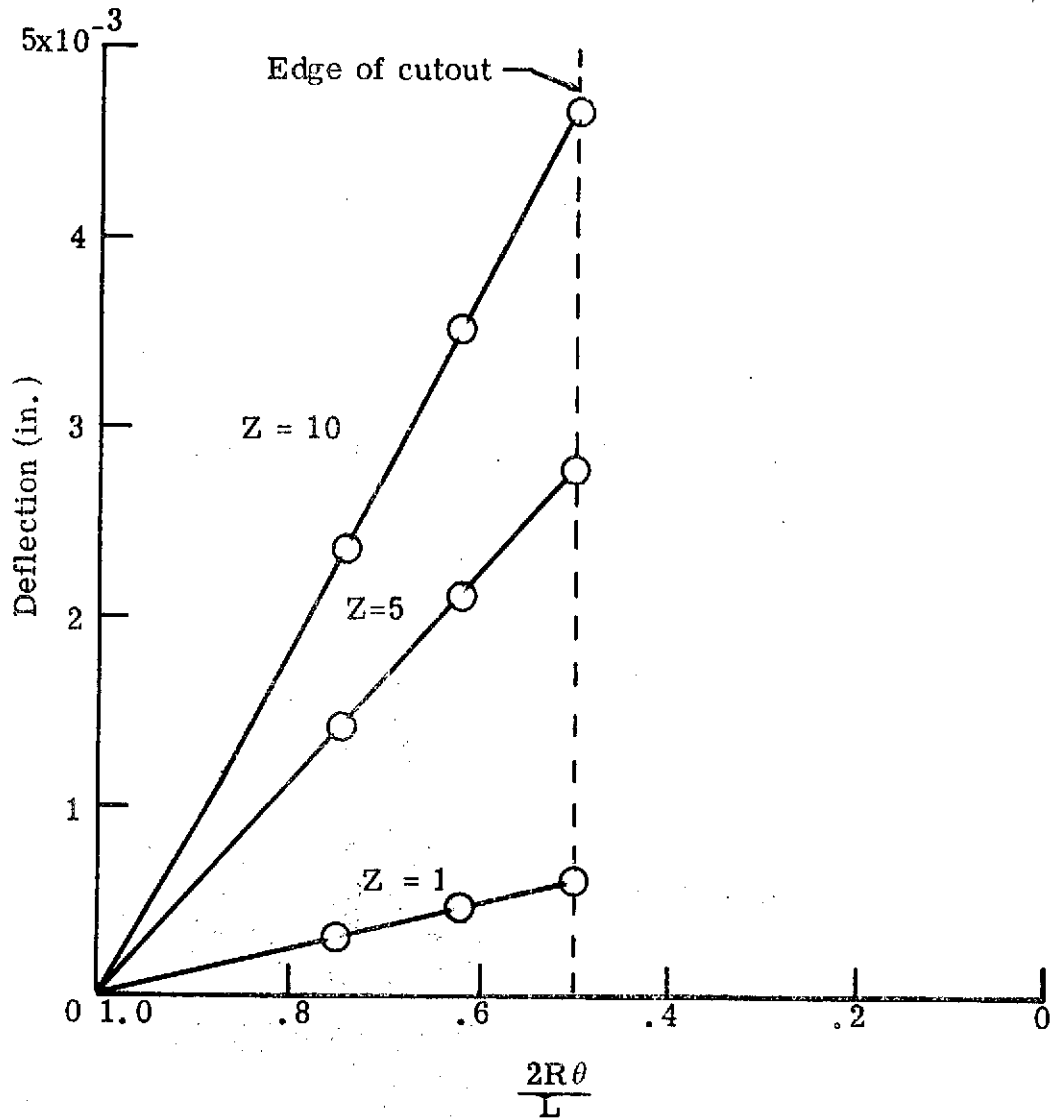

Figure V.-9 Normal deflection along  $X=0$  due to a uniform axial load of  $-1.0 \text{ lb./in.}$

curvature parameters of 0. (a flat plate), 1., 5. and 10., respectively. These plots show the influence of increasing the cutout size is progressively more drastic as the curvature is increased. This increased sensitivity to cutouts as the curvature increases is directly attributable to the sharp increase in prebuckling deformation which was shown to occur in figures V-7, V-8, and V-9. For example, when the curved panel with  $Z = 10$  and  $a/L = 0.5$  was analyzed without using  $[\bar{K}^2]$ ,  $N_{CR}$  was 4.70 lb/in. However, when the problem was resolved, using  $[\bar{K}^2]$ ,  $N_{CR}$  was 0.439 lb/in. The larger the prebuckling deformations, the greater the influence of the initial displacement stiffness matrix. It should be noted that even in this case, the prebuckling deformation,  $w$ , is more than an order of magnitude smaller than the panel thickness.

The data used to plot figures V-10, V-11, V-12, and V-13 was cross-plotted to produce figure V-14. In this figure, the influence of curvature on the buckling strength of panels with various cutout sizes is shown. When the cutout is small, the buckling strength of the panel is seen to increase as the curvature increases. This is the same trend exhibited by curved panels with no cutout. However, for panels having a larger cutout ( $a/L=0.25$  and  $0.50$ ) this trend is reversed. For the larger cutout sizes, increasing the curvature reduces the buckling strength. There are two opposing trends involved here. On the one hand, curvature tends to stiffen a panel, while on the other, curvature increases the magnitude of the prebuckling deformations.

It is clear from the preceding that the initial deformation stiffness matrix becomes increasingly important as the hole size and curvature increase. This raises a question as to the importance of the non-linear terms which occur in that matrix. In order to explore this



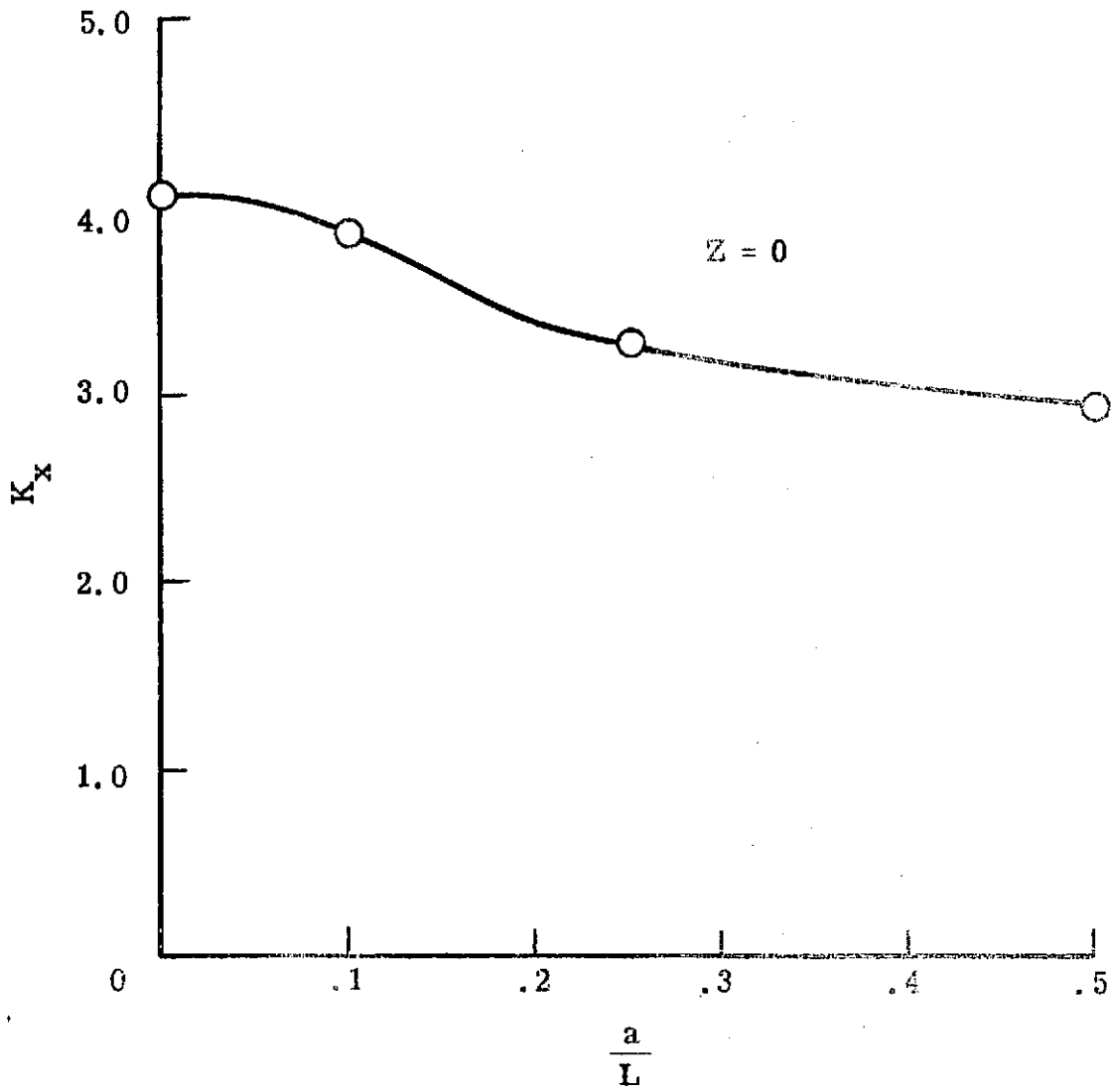

Figure V, -10 Buckling of a flat plate with varying cutout size.

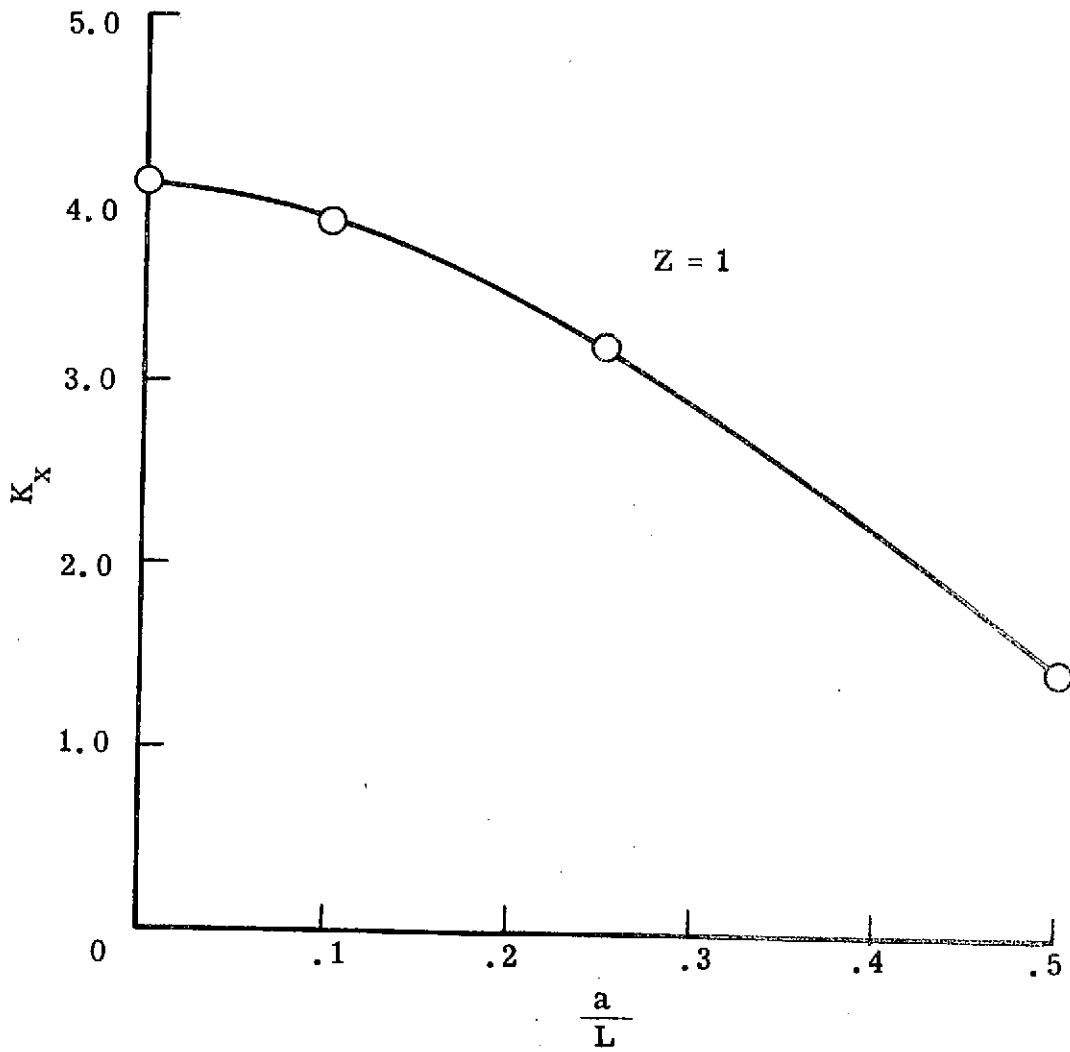

Figure V. -11 Buckling of a curved panel ( $Z=1$ ) with varying cutout size

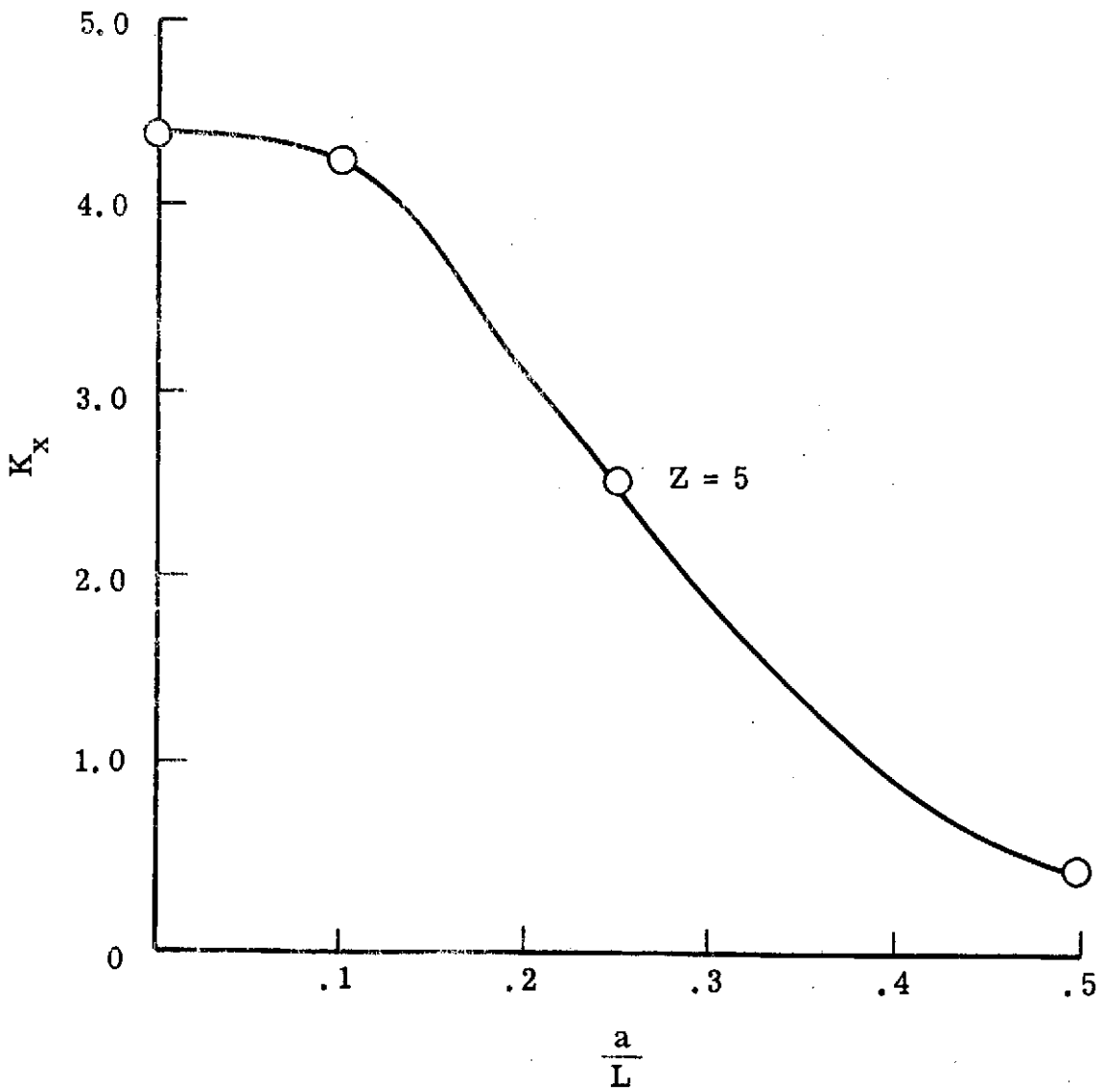

Figure V. -12. Buckling of a curved panel ( $Z=5$ ) with varying cutout size.

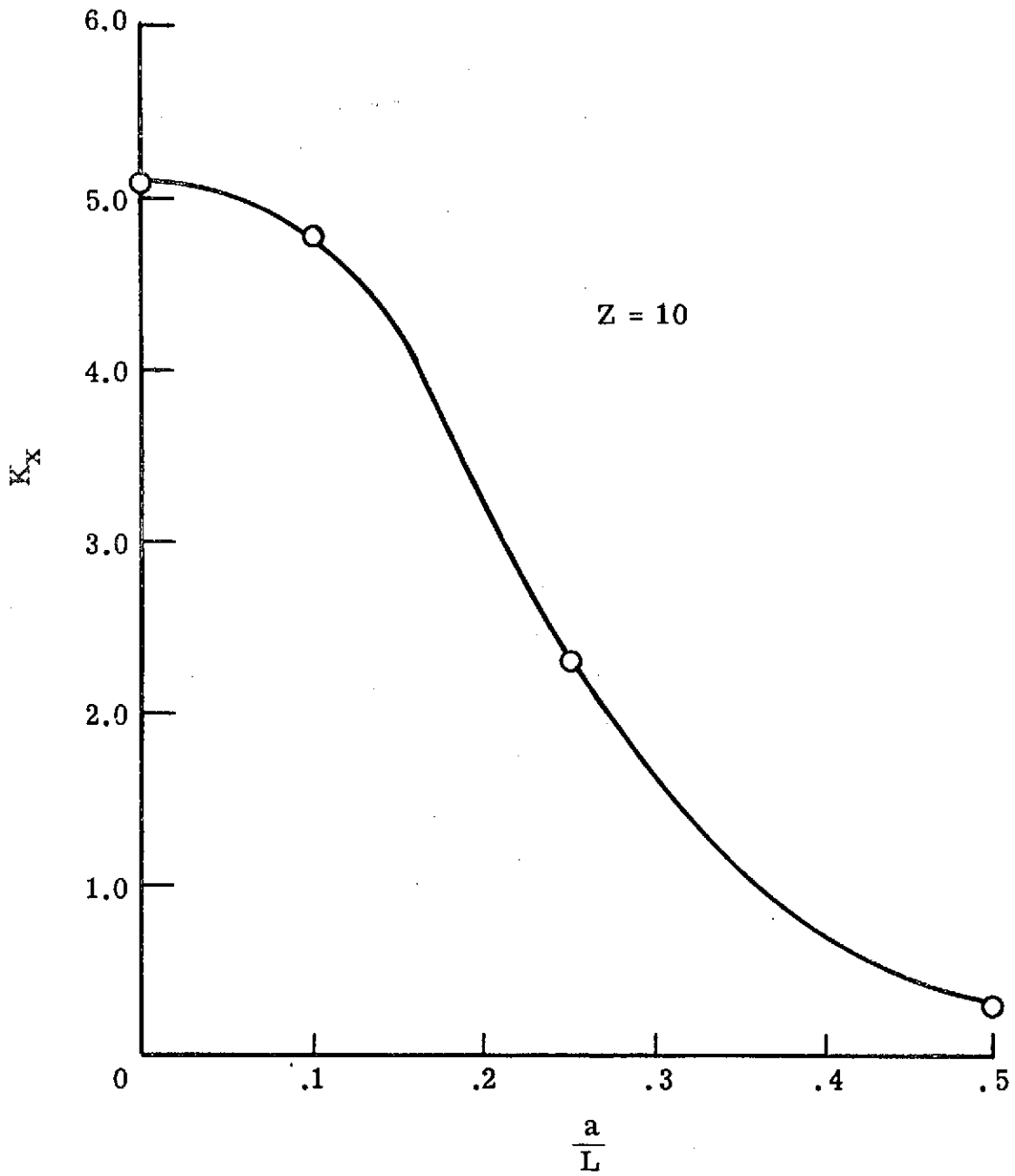

Figure V. - 13 Buckling of a curved panel ( $Z = 10$ ) with varying cutout size.

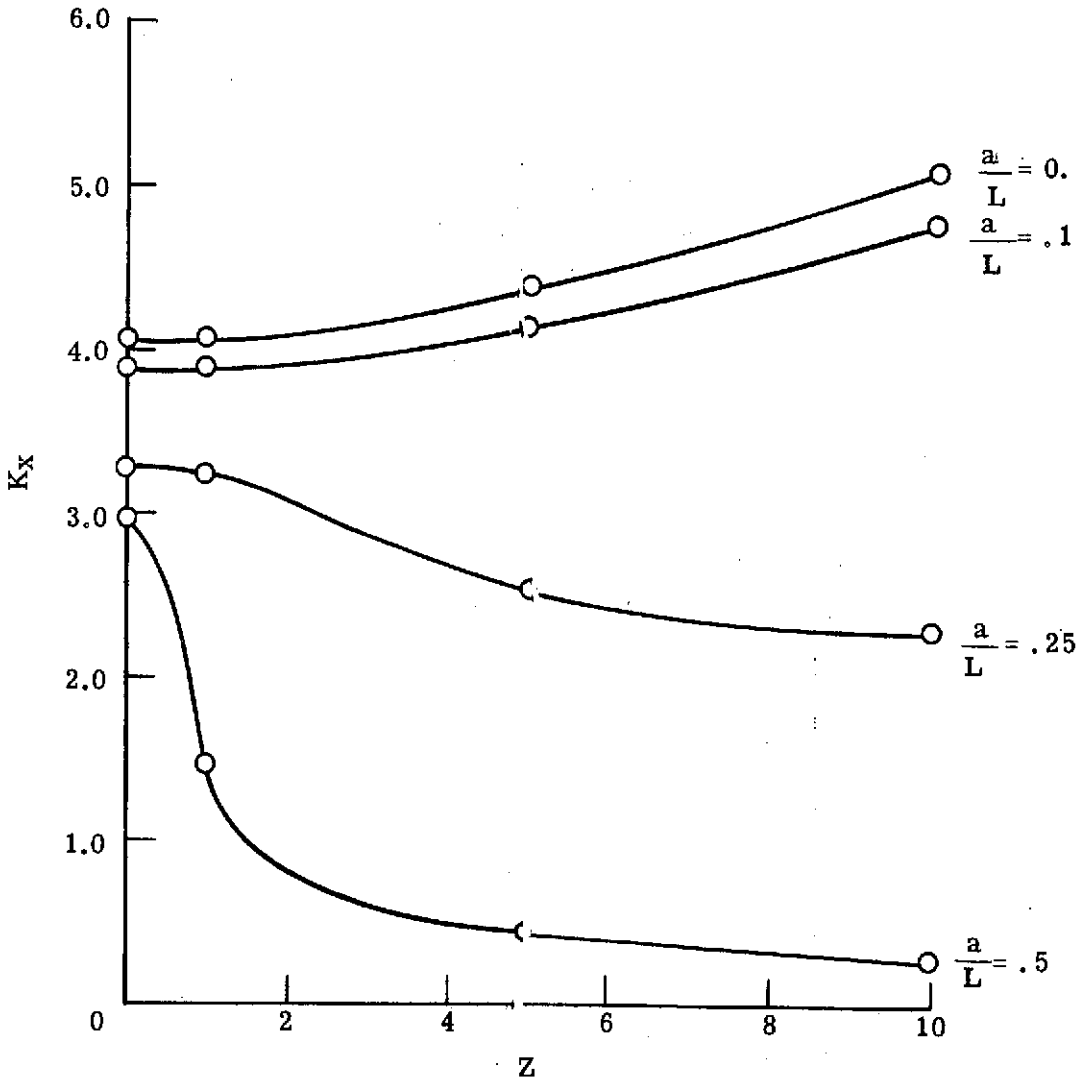

Figure V - 14. Buckling of curved panels with varying curvature and cutout size.

question, an iterative approach to the problem was taken. This required reformulating the problem. First, all of the terms in the  $[\bar{K}^2]$  matrix of Chapter III are retained. The  $[\bar{K}^2]$  matrix may now be considered the sum of two matrices  $[\bar{K}^{2'}]$  and  $[\bar{K}^{2''}]$ ; where  $[\bar{K}^{2'}]$  contains only linear  $\beta$  terms and  $[\bar{K}^{2''}]$  contains only squared  $\beta$  terms. Equation IV-4 may thus be rewritten as

$$\left| \frac{1}{\lambda_i} [I] + [\bar{K}^0]^{-1} \left[ [\bar{K}^1] + [\bar{K}^{2'}] + \lambda_{i-1} [\bar{K}^{2''}] \right] \right| = 0 \quad (V-4)$$

where

$\lambda_i$  is the  $i$ th solution to equation V-4

Equation V-4 was solved iteratively by making successive computer runs for the case of a panel having a  $Z = 10$  and  $a/L = 0.5$ . This case was chosen because it produces large values of  $\beta_1$  and  $\beta_2$  and hence should be the most sensitive to the use of the  $\beta^2$  terms. The buckling load obtained without using the  $\beta^2$  term was 0.43939 lb/in. After three iterations, the solution had converged to a value of 0.44019 lb/in. This is a change of 0.182 percent. Hence, the influence of the  $\beta^2$  terms in the initial deformation stiffness matrix is seen to be relatively small for the range of parameters considered in this investigation. However, for cases involving larger initial deformations an iterative solution would be desirable.

While no test data is available to directly substantiate the analytical results obtained for panels with a square cutout, the test data obtained by Tennyson (ref. 18) and the conclusions he drew from it are in general agreement with the findings reported in this chapter. For

example, no reduction in buckling strength is shown for a ratio of cutout radius,  $a$ , to the cylinder radius,  $R$ , of 0.03 but when  $a/R$  is increased to 0.08, a 40 percent reduction in buckling strength is found to occur. Tennyson cites the prebuckling deformation as being a primary factor in the reduction of the buckling strength.

## CHAPTER VI.

CONCLUDING REMARKS

A cylindrical finite element suitable for the linear stability analysis of cylindrical shells has been developed. Energy principles and variational methods have led to a problem formulation which lends itself to physical interpretations of the governing matrices of the finite element. By properly grouping the terms which result from taking the second variation of the potential energy of the element, it is possible to identify three distinct types of matrices. These three matrices are:

1. the conventional stiffness matrix,  $[K^0]$
2. the "initial stress" stiffness matrix,  $[K^1]$ , which is a function of the prebuckling stress distribution.
3. the "initial displacement" stiffness matrix,  $[K^2]$ , which is a function of the prebuckling deformations.

With the assumption of linearity, the buckling problem was stated in terms of the classical linear real eigenvalue equation. While the stiffness matrix was previously derived, the formulation of the initial stress and initial displacement stiffness matrices is original. A computer program coded in Fortran IV language was developed for use on the CDC 6600 series computer.

The computer program was used to solve several classes of problems which have known closed form solutions. Agreement between theoretical and computer solutions for the column, the flat plate, the arch and the



curved panel are good. The arch solution bears special note since the loading in that case is radial. Hence, the applicability of the technique to pressure-loaded structures is assured. A major difficulty encountered in the development of the computer program was providing for enough degrees of freedom to allow adequate characterization of the problem. The computer core storage required by the program is substantial. In order to accommodate 36 grid points, representing 216 degrees of freedom, overlay programming procedures had to be followed in addition to utilizing the entire core storage of 300,000 octal locations. The analyses presented in Chapter V indicate that better accuracy could be obtained by using more elements.

The application of the computer program to the buckling of curved panels with cutouts reveals interesting trends. While test data has established that, for certain sized cutouts, the buckling strength of a cylinder is reduced as the curvature increases; intuition dictates that for small cutouts, the stiffening effects of increasing curvature should outweigh the detrimental effects of a cutout. The analytical results for the case of  $a/L = .1$  confirms intuition.

A number of areas for additional research are apparent as a result of this work. By adding beam elements to the existing program, it would be possible to evaluate the size of doublers that should be placed around the cutout in order to develop higher buckling strength. The convergence of the analysis could be improved in several ways. For instance, a more complex displacement function could be used in the

development of the "initial stress" and "initial displacement" stiffness matrices. While this is conceptually straightforward, the work involved is formidable. The utilization of an iterative type of solution similar to that presented in Chapter V, is another possibility for improving convergence. Since the first variation of the potential energy, which is the basis for the static analysis, actually contains the initial stress and initial displacement stiffness matrices, the load could be applied incrementally until bifurcation occurs. These schemes would substantially increase computing time.

Since cylindrical structures with cutouts frequently occur in the design of aircraft and space vehicles, it would be highly desirable if test programs were initiated to substantiate the analytical findings presented herein.

## CHAPTER VII.

REFERENCES

1. Turner, M. J., Clough, R. C., Martin, H. C., and Topp, L. J. "Stiffness and Deflection Analysis of Complex Structures" Journal of Aeronautical Sciences, September, 1956.
2. Turner, J. J.; Dill, E. H.; Martin, H. C. and Melosh, M. J.; "Large Deflections of Structures Subjected to Heating and External Loads," Journal of the Aerospace Sciences, February 1960, pp. 97 - 107, 27.
3. Turner, M. J.; Martin, H. C. and Weikel, R. C.; "Further Development and Applications of the Stiffness Method," AGARD Structures and Material Panel, Paris, France, July 6, 1962.
4. Gallagher, R. and Padlog, J., "Discrete Element Approach to Structural Instability Analysis," AIAA Journal, Vol. 1, No. 6, June 1963, p. 1437.
5. Martin, H., "On the Derivation of Stiffness Matrices for the Analysis of Large Deflection and Stability Problems," Proceedings of Conference on Matrix Methods in Structural Mechanics, Air Force Institute of Technology, Dayton, O., 1965 (AFFDL RR 66-80)
6. Martin, H. C., "Large Deflection and Stability Analysis by the Direct Stiffness Method," Jet Propulsion Laboratory Report No. 32-931, 1965.
7. Przemieniecki, J. S. and Purdy, D. M., "Large Deflection and Stability Analysis of Two Dimensional Truss and Frame Structures," Air Force Report AFFDL-TR-68-38, May 1968.
8. Gallagher, R. H.; Gellatly, R. A.; Padlog, U.; and Mallett, R. H.; "A Discrete Element Procedure for Thin Shell Instability Analysis," AIAA Journal, June 1963.
9. Kapur, K. and Hartz, B.; "Stability of Plates Using the Finite Element Method," Proc. ASCE, Journal of Engineering Mechanics Division, Vol. 92, No. EM2, April 1966.
10. Navaratna, D. R.; Pian, T. H. H. and Witmer, E. A., "Stability Analysis of Shells of Revolution by the Finite-Element Method," AIAA Journal, Vol. 6, No. 2, February 1968.

11. Bogner, F.; Fox, R., and Schmit, L, "Finite Deflection Analysis Using Plate and Cylindrical Shell Descrete Elements," AIAA Journal, Vol. 6, No. 5, May 1968.
12. Timoshenko, S. P. and Gere, J. M., "Theory of Elastic Stability," McGraw-Hill Book Company, Inc., 1961.
13. Koiter, W. T., "Buckling and Post Buckling Behavior of a Cylindrical Panel Under Axial Compression," Report S-476, 1956, Nat. Liechvaartlab., Amsterdam, Holland.
14. Gerard, G., and Becker, H., "Handbook of Structural Stability, Part III-Buckling of Curved Plates and Shells," NACA TN3783, 1957.
15. Rehfield, L. W. and Hallaur, W. L., "Edge Restraint Effect on Buckling of Compressed Curved Panels," AIAA Journal, Vol. 6, No. 1, January 1968.
16. Snyder, R. E., "An Experimental Investigation of the Effect of Circular Cutouts on the Buckling Strength of Circular Cylindrical Shells loaded in Axial Compression," Masters Thesis, Virginia Polytechnic Institute, 1965.
17. Brogan, F. and Almroth, B., "Buckling of Cylinders with Cutouts," AIAA Paper No. 69-62, January 1969.
18. Tennyson, R. C., "The Effects of Unreinforced Circular Cutouts on the Buckling of Circular Cylindrical Shells Under Axial Compression," Journal of Engineering for Industry, November 1968.
19. Langhaar, Henry L., "Energy Methods in Applied Mechanics," John Wiley and Sons, Inc., 1962.
20. Bisplinghoff, R. L.; Ashley, Holt; and Holfman, Robert L., "Aeroelasticity," Addison-Wesley Publishing Company, Inc., Reading, Mass. 1957.
21. Mollett R., and Berke, L., "A Comparative Evaluation of Finite Element Methods for Nonlinear Pre- and Post-Buckling Analysis," Proc: of the Second AFIT Conference on Matrix Methods in Structural Mechanics, October 1968.
22. Gallagher, R., Gellatly R., Mallett R., and Padlog, J., "A Discrete Element Procedure for Thin Shell Instability Analysis," AIAA Journal, Vol. 5, No. 1, January 1967.

23. Navaratna, D., Pean, T., and Witmer, E., "Analysis of Elastic Stability of Shells of Revolution by the Finite Element Method," AIAA Journal, Vol. 6, No. 2, February 1968.
24. Mallett, R. and Marcal, P., "Finite Element Analysis of Non-linear Structures," Proc. ASCE, Journal of the Structural Division, August 1968.
25. Gallagher, R. "The Development and Evaluation of Matrix Methods for Thin Shell Structural Analysis," Ph.D. Dissertation, State University of New York at Buffalo, June, 1966.
26. Sanders, J., Lyell, Jr., "Nonlinear Theories for Thin Shells," Quarterly of Applied Mathematics, Vol. 21, No. 1, 1963, pages 21 - 36.
27. Zienkiewicz, O. and Cheung, Y., "The Finite Element Method in Structural and Continuum Mechanics," Chapter 2, McGraw-Hill Publishing Company, Ltd., London, 1967.
28. Cantin, R., and Clough, R., "A Curved Cylindrical-Shell Finite Element," AIAA Journal, Vol. 6, June, 1968.
29. Haisler, W., and Stricklin, J., "Rigid-Body Displacements of Curved Elements in the Analysis of Shells by the Matrix Displacement Method," AIAA Journal, Vol. 5, No. 8, August 1967.
30. Argyris, J., H., and Kelsey, S., "Energy Theorems and Structural Analysis," Butterworths Publishers, London, 1961.
31. Melosh, R., "Basis for Derivation of Matrices for the Direct Stiffness Method," AIAA Journal, July, 1963.
32. Norris, C. and Wilbur, J., "Elementary Structural Analysis," McGraw-Hill Book Company, New York, 1952.
33. Anon. "Langley Research Center Computer Programming Manual."
34. Fox, L., "An Introduction to Numerical Linear Algebra."
35. Francis, J., G., F., "The Q.R. Transformation," The Computer Journal Part I, Vol. 4, No. 5, pp. 265 - 271 and Part II *ibid*, January, 1962, pp. 332-345.
36. Den Hartog, J. P., "Advanced Strength of Materials" McGraw-Hill Book Company, Incorporated, 1952.

37. Batdorf, S. B., and Schildcrout, Murry, "Critical Axial-Compressive Stress of a Curved Rectangular Panel with a Central Chordwise Stiffener," NACA TN 1661, July 1948.
38. Lur'e, A. I., "Concentration of Stress in the Vicinity of an Aperture in the Surface of a Circular Cylinder," (Translated from Russian) Prekladnia Malmalika I Mechhanika, Vol. 10, 1946, p. 397.
39. Naghdi, A. K., and Eringen, A. C., "Stress Analysis of a Circular Cylindrical Shell with Circular Control," General Technology Corporation Technical Report No. 3-2.
40. Savin, G. N.; "Stress Distribution Around Holes", NASA TT F-607, November, 1970.
41. Savin, G. N., and Guz, A. N.; "On The State of Stress Near Curvilinear Holes in Shells", NASA TT F-423, May, 1966.

## CHAPTER VIII.

ACKNOWLEDGMENTS

The author is deeply indebted to Dr. Robert E. Fulton of NASA's Langley Research Center for his guidance and encouragement. He also wishes to thank Dr. Daniel Frederick, Head of the Department of Engineering Mechanics, Virginia Polytechnic Institute for his help in this research. He wishes to express gratitude to the National Aeronautics and Space Administration and to his supervisors, Mr. F. E. Mershon and Mr. E. B. Geer who supported his work. Finally, he wishes to thank his wife, Berlie and their children for the patience and understanding they have shown.

## CHAPTER IX.

VITA

Mr. Snyder was born [REDACTED] and graduated from Cathedral High School there in 1954. He served three years in the United States Marine Corps. In 1962, he graduated from the University of Nebraska with a Bachelor of Science degree in Civil Engineering. Since graduation, Mr. Snyder has been employed by the National Aeronautics and Space Administration at Langley Research Center in Hampton, Virginia. He is presently a member of the Viking Project Office. He began graduate study in 1962 and received a Master of Science degree in Engineering Mechanics from Virginia Polytechnic Institute in 1965. In 1967 he embarked on the Doctor of Philosophy program. He is a member of Sigma Tau and Chi Epsilon.

Mr. Snyder is married to the former Alberta L. [REDACTED] and they live in Hampton, Virginia, with their four children, Kathleen, Steven, Scott and William.

■



## CHAPTER X.

APPENDIX A - THE DEVELOPMENT OF THE CONVENTIONAL,  
THE INITIAL STRESS AND THE INITIAL DISPLACEMENT STIFFNESS MATRICES  
FOR THE BEAM-COLUMN AND ARCH ELEMENTS.

Development of the Stiffness, Initial Stress and Initial Displacement Stiffness Matrices for an beam-column and arch are presented in this appendix.

X-1 The Beam Column

The equation for the second variation of the potential energy for the beam-column element shown in Figure II-1 is:

$$\delta^2 \pi = \int_0^L \begin{bmatrix} \delta \varepsilon & \delta \phi & \delta w_{,xx} \end{bmatrix} \left\{ EA \begin{bmatrix} 1 & 0 & 0 \\ 0 & 0 & 0 \\ 0 & 0 & I/A \end{bmatrix} + \begin{bmatrix} 0 & 0 & 0 \\ 0 & N & 0 \\ 0 & 0 & 0 \end{bmatrix} + EA \begin{bmatrix} 0 & \phi & 0 \\ \phi & \phi^2 & 0 \\ 0 & 0 & 0 \end{bmatrix} \right\} \begin{Bmatrix} \delta \varepsilon \\ \delta \phi \\ \delta w_{,xx} \end{Bmatrix} dX \quad (A-1)$$

The strains  $\varepsilon$ ,  $\phi$  and  $w_{,xx}$  are related to the displacements  $u$  and  $w$  as follows:

$$\{\bar{\varepsilon}\} = [A]\{d\} \quad (A-2)$$

where

$$\{\bar{\varepsilon}\}^T = \begin{bmatrix} \varepsilon & \phi & w_{,xx} \end{bmatrix}$$

$$[A] = \begin{bmatrix} 1 & 0 & 0 \\ 0 & 1 & 0 \\ 0 & 0 & 1 \end{bmatrix}$$

$$\{d\}^T = \begin{bmatrix} u_{,x} & w_{,x} & w_{,xx} \end{bmatrix}$$

$\{d\}$  is related to  $u$  and  $w$  through a matrix of differential operators.

$$\{d\} = [D]\{g\} \quad (A-3)$$

where

$$[D] = \begin{bmatrix} 0 & 1 \\ d/dx & 0 \\ 0 & d/dx \\ 0 & d^2/dx^2 \end{bmatrix}$$

$$\{g\}^T = [u \ w] \quad (A-4)$$

Linear and cubic displacement functions for  $u$  and  $w$  are written as:

$$\{g\} = [B]\{\gamma\}$$

where:

$$[B] = \begin{bmatrix} 1 & x & 0 & 0 & 0 & 0 \\ 0 & 0 & 1 & x & x^2 & x^3 \end{bmatrix}$$

$$\{\gamma\}^T = [\gamma_1 \ \gamma_2 \ \gamma_3 \ \gamma_4 \ \gamma_5 \ \gamma_6]$$

and  $\{\gamma\}$  is related to the displacements at ends 1 and 2 of the beam-column element by

$$\{\gamma\} = [\Gamma]\{\Delta\} \quad (A-5)$$

where

$$[\Gamma] = \begin{bmatrix} 1 & 0 & 0 & 0 & 0 & 0 \\ -1/l & 0 & 0 & 1/l & 0 & 0 \\ 0 & 1 & 0 & 0 & 0 & 0 \\ 0 & 0 & -1 & 0 & 0 & 0 \\ 0 & -3/l^2 & 2/l & 0 & 3/l^2 & 1/l \\ 0 & 2/l^3 & -1/l^2 & 0 & -2/l^3 & -1/l^2 \end{bmatrix}$$

$$\{\Delta\}^T = [u_1 \ w_1 \ \theta_1 \ u_2 \ w_2 \ \theta_2]$$

Substituting A-3, A-4, and A-5 into A-2

$$\{\bar{\epsilon}\} = [A][D][B][\Gamma]\{\Delta\} \quad (\text{A-6})$$

Thus

$$\{\delta\bar{\epsilon}\} = [G]\{\delta\Delta\} \quad (\text{A-7})$$

where

$$[G] = [A][D][B][\Gamma]$$

Equation A-1 may now be conveniently written as

$$\begin{aligned} \delta^2\pi = & \int_0^L \{\delta\Delta\}^T [G]^T [K^0] [G] \{\delta\Delta\} dx + \int_0^L \{\delta\Delta\}^T [G]^T [K^1] [G] \{\delta\Delta\} dx \\ & + \int_0^L \{\delta\Delta\}^T [G]^T [K^2] [G] \{\delta\Delta\} dx \end{aligned} \quad (\text{A-8})$$

where, as in section VI

$$[\hat{K}^0] = EA \begin{bmatrix} 1 & 0 & 0 \\ 0 & 0 & 0 \\ 0 & 0 & I/A \end{bmatrix}; \quad [\hat{K}^1] = \begin{bmatrix} 0 & 0 & 0 \\ 0 & N & 0 \\ 0 & 0 & 0 \end{bmatrix}; \quad [\hat{K}^2] = EA \begin{bmatrix} 0 & \phi & 0 \\ \phi & \phi^2 & 0 \\ 0 & 0 & 0 \end{bmatrix}$$

Assuming E, A and I to be constants, the first term of equation A-8

becomes

$$\{\delta\Delta\}^T [K_e^0] \{\delta\Delta\}$$

where

$$[K_e^0] = EA \begin{bmatrix} \frac{1}{\ell} & & & & & \\ 0 & \frac{12I}{A\ell^3} & & & & \\ & & \text{SYMMETRIC} & & & \\ 0 & -\frac{6I}{A\ell^2} & \frac{4I}{A\ell} & & & \\ -\frac{1}{\ell} & 0 & 0 & \frac{1}{\ell} & & \\ 0 & -\frac{12I}{A\ell^3} & \frac{6I}{A\ell^2} & 0 & \frac{12I}{A\ell^3} & \\ 0 & -\frac{6I}{A\ell^2} & \frac{2I}{A\ell} & 0 & \frac{6I}{A\ell^2} & \frac{4I}{A\ell} \end{bmatrix}$$

This is the stiffness matrix for a two dimensional beam-column element. This matrix agrees with the stiffness matrix for a beam-column published in reference 5.

The second term of equation A-8, assuming N a constant, is

$$\{\delta\Delta\}^T [K_e^1] \{\delta\Delta\}$$

where

$$[K_e^1] = N \begin{bmatrix} 0 & & & & & \\ 0 & \frac{6}{5\ell} & & & & \\ & & \text{SYMMETRIC} & & & \\ 0 & -\frac{1}{10} & \frac{2\ell}{15} & & & \\ 0 & 0 & 0 & 0 & & \\ 0 & -\frac{6}{5\ell} & \frac{1}{10} & 0 & \frac{6}{5\ell} & \\ 0 & -\frac{1}{10} & -\frac{2}{30} & 0 & \frac{1}{10} & \frac{2\ell}{15} \end{bmatrix}$$

This is the initial stress stiffness matrix for a two dimensional beam-column element. This is exactly the matrix obtained in reference 5 for a beam column initial stress stiffness matrix.

Assuming  $\phi$  to be a constant over the length of the element, the third matrix of equation A-8 becomes

$$\{\delta\Delta\}^T [K_e^2] \{\delta\Delta\}$$

where

$$[K_e^2] = E A \begin{bmatrix} 0 & & & & & \\ \frac{\phi}{\ell} & \frac{66\phi^2}{5\ell} & & & & \\ & & \text{SYMMETRIC} & & & \\ 0 & -\frac{\phi^2}{10} & \frac{52\phi^2\ell}{15} & & & \\ & & & & & \\ 0 & -\frac{\phi}{\ell} & 0 & 0 & & \\ -\frac{\phi}{\ell} & -\frac{66\phi^2}{5\ell} & \frac{\phi^2}{10} & \frac{\phi}{\ell} & \frac{66\phi^2}{5\ell} & \\ 0 & -\frac{\phi^2}{10} & -\frac{109\phi^2}{30} & 0 & -\frac{\phi^2}{10} & \frac{2\phi^2}{15} \end{bmatrix}$$

This is the initial displacement stiffness matrix for a two dimensional beam-column element.

#### X-2 The Arch

The strain displacement relations for the arch element shown in figure A-1 may be stated in the form of equation A-2 by redefining the terms on the right hand side of that equation as follows

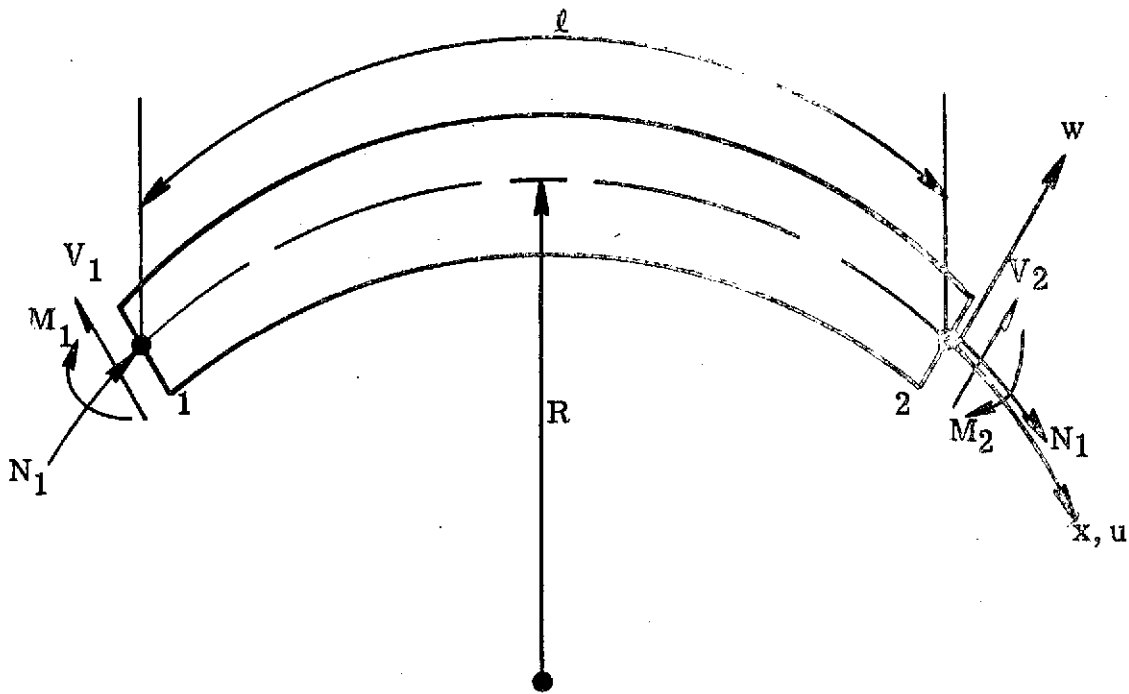

Figure A-1. Arch element

$$[A] = \begin{bmatrix} 1/R & 1 & 0 & 0 \\ 0 & 0 & 1 & 0 \\ 0 & 0 & 0 & 1 \end{bmatrix}$$

$$\{d\}^T = [w \ u, x \ w, x \ w, xx]$$

The remaining matrices and matrix operations for the arch are exactly the same as those for the beam-column. The resulting conventional, initial stress and initial displacement stiffness matrices are as follows:

$$[K_e^0] = EA \begin{bmatrix} \frac{1}{\ell} & & & & & \\ -\frac{1}{2R} & \frac{13}{35} \frac{\ell}{R^2} + \frac{12I}{A\ell^3} & & & & \\ \frac{\ell}{12R} & -\frac{11}{210} \frac{\ell^2}{R^2} - \frac{6I}{A\ell^2} & \frac{\ell^3}{105R^2} + \frac{4I}{A\ell} & & & \\ -\frac{1}{\ell} & \frac{1}{2R} & -\frac{\ell}{12R} & \frac{1}{\ell} & & \\ -\frac{1}{2R} & \frac{9}{70R^2} - \frac{12I}{A\ell^3} - \frac{13\ell^2}{420R^2} + \frac{6I}{A\ell^2} & \frac{1}{2R} \frac{13\ell}{35R^2} + \frac{12I}{A\ell^3} & & & \\ -\frac{1}{12R} & \frac{13\ell^2}{420R^2} - \frac{6I}{A\ell^2} - \frac{\ell^3}{140R^2} + \frac{2I}{A\ell} & \frac{\ell}{12R} \frac{11}{210} \frac{\ell^2}{R^2} + \frac{6I}{A\ell^2} \frac{\ell^3}{105R^2} + \frac{4I}{A\ell} & & & \end{bmatrix}$$

SYMMETRIC

$$[K_e^1] = N$$

0	SYMMETRIC				
0	$\frac{6}{5\ell}$				
0	$-\frac{1}{10}$	$\frac{2\ell}{15}$			
0	0	0	0		
0	$-\frac{6}{5\ell}$	$\frac{1}{10}$	0	$\frac{6}{5\ell}$	
0	$-\frac{1}{10}$	$-\frac{\ell}{30}$	0	$\frac{1}{10}$	$\frac{2\ell}{15}$

$$[K_e^2] = EA$$

0	SYMMETRIC				
$\frac{\phi}{\ell} - \frac{\phi}{R} + \frac{66\phi^2}{5\ell}$					
0	$-\frac{\phi^2}{10}$	$\frac{52\phi^2\ell}{15}$			
0	$-\frac{\phi}{\ell}$	0	0		
$-\frac{\phi}{\ell}$	$\frac{\phi}{R} - \frac{66\phi^2}{5\ell}$	$\frac{\phi^2}{10}$	$\frac{\phi}{\ell}$	$\frac{\phi}{R} + \frac{66\phi^2}{5\ell}$	
0	$-\frac{\phi^2}{10}$	$-\frac{109\phi^2}{30}$	0	$-\frac{\phi^2}{10}$	$\frac{2\phi^2}{15}$



## CHAPTER XI.

APPENDIX B.- THE PRINCIPAL MATRICES IN THE DEVELOPMENT  
OF THE INITIAL STRESS AND INITIAL DISPALCEMENT MATRICES  
FOR THE CYLINDRICAL ELEMENT

The explicit statement of the principal matrices involved in deriving the Initial Stress and Initial Displacement Stiffness Matrices is given in this Appendix. The terminology used herein is consistant with that used in Chapter III.

$$[A] = \begin{bmatrix} 0 & 0 & 0 & 1 & 0 & 0 & 0 & 0 & 0 & 0 & 0 & 0 \\ 0 & 0 & 0 & 0 & 0 & 0 & 0 & -1 & 0 & 0 & 0 & 0 \\ 0 & 0 & 0 & 0 & 0 & 0 & 0 & 0 & 0 & -1 & 0 & 0 \\ 0 & 0 & 0 & 0 & \frac{1}{R} & 1 & 0 & 0 & 0 & 0 & 0 & 0 \\ 0 & 0 & \frac{1}{R} & 0 & 0 & 0 & \frac{1}{R} & 0 & 0 & 0 & 0 & 0 \\ 0 & \frac{1}{R} & 0 & 0 & 0 & 0 & 0 & 0 & -\frac{1}{R} & 0 & 0 & 0 \\ 0 & 0 & 0 & 0 & 0 & 0 & \frac{1}{R^2} & 0 & 0 & 0 & -\frac{1}{R^2} & 0 \\ 0 & 0 & 0 & 0 & -\frac{1}{2R^2} & \frac{3}{2R} & 0 & 0 & 0 & 0 & 0 & -\frac{2}{R} \end{bmatrix} \quad (B-1)$$

$$[D] = \begin{bmatrix} 1 & 0 & 0 \\ 0 & 1 & 0 \\ 0 & 0 & 1 \\ \frac{\partial}{\partial x} & 0 & 0 \\ \frac{\partial}{\partial \theta} & 0 & 0 \\ 0 & \frac{\partial}{\partial x} & 0 \\ 0 & \frac{\partial}{\partial \theta} & 0 \\ 0 & 0 & \frac{\partial}{\partial x} \\ 0 & 0 & \frac{\partial}{\partial \theta} \\ 0 & 0 & \frac{\partial^2}{\partial x^2} \\ 0 & 0 & \frac{\partial^2}{\partial \theta^2} \\ 0 & 0 & \frac{\partial^2}{\partial x \partial \theta} \end{bmatrix}$$

(B-2)

$$[B] = \frac{1}{ab} \begin{bmatrix} (x-a)(R\theta-b) & -x(R\theta-b) & xR\theta & -R\theta(x-a) & 0 & 0 & 0 & 0 & 0 & 0 & 0 & 0 \\ 0 & 0 & 0 & 0 & (x-a)(R\theta-b) & -x(R\theta-b) & xR\theta & -R\theta(x-a) & 0 & 0 & 0 & 0 \\ 0 & 0 & 0 & 0 & 0 & 0 & 0 & 0 & (x-a)(R\theta-b) & -x(R\theta-b) & xR\theta & -R\theta(x-a) \end{bmatrix} \quad (B-3)$$

$$[G] = \frac{1}{ab} \begin{bmatrix} R\theta-b & -(R\theta-b) & R\theta & -R\theta & 0 & 0 & 0 & 0 & 0 & 0 & 0 & 0 \\ 0 & 0 & 0 & 0 & 0 & 0 & 0 & 0 & -(R\theta-b) & R\theta-b & -R\theta & R\theta \\ 0 & 0 & 0 & 0 & 0 & 0 & 0 & 0 & 0 & 0 & 0 & 0 \\ (x-a) & -x & x & -(x-a) & R\theta-b & -(R\theta-b) & R\theta & -R\theta & 0 & 0 & 0 & 0 \\ 0 & 0 & 0 & 0 & (x-a) & -x & x & -(x-a) & \frac{1}{R}(x-a)(R\theta-b) & -\frac{x}{R}(R\theta-b) & \frac{xR\theta}{R} & -\frac{R\theta}{R}(x-a) \\ 0 & 0 & 0 & 0 & \frac{1}{R}(x-a)(R\theta-b) & -\frac{x}{R}(R\theta-b) & \frac{xR\theta}{R} & -\frac{R\theta}{R}(x-a) & -(x-a) & x & -x & (x-a) \\ 0 & 0 & 0 & 0 & \frac{(x-a)}{R} & -\frac{x}{R} & \frac{x}{R} & -\frac{(x-a)}{R} & 0 & 0 & 0 & 0 \\ -\frac{(x-a)}{2R} & \frac{x}{2R} & -\frac{x}{2R} & \frac{(x-a)}{2R} & \frac{3}{2R}(R\theta-b) & -\frac{3}{2R}(R\theta-b) & \frac{3R\theta}{2R} & -\frac{3R\theta}{2R} & -2 & 2 & -2 & 2 \end{bmatrix} \quad (B-4)$$

TABLE B-1 Elements of  $[G]^T[\hat{K}^1][G]$ 

$$h_{2,2} = N_2 \frac{(X-a)^2(R\theta-b)^2}{R^2}$$

$$h_{3,2} = -N_{12} \frac{(X-a)(R\theta-b)^2}{R} - N_2 \frac{(X-a)^2(R\theta-b)}{R}$$

$$h_{8,2} = -N_2 \frac{X(X-a)(R\theta-b)^2}{R^2}$$

$$h_{9,2} = N_{12} \frac{(X-a)(R\theta-b)^2}{R} + N_2 \frac{X(X-a)(R\theta-b)}{R}$$

$$h_{14,2} = N_2 \frac{XR\theta(X-a)(R\theta-b)}{R^2}$$

$$h_{15,2} = -N_{12} \frac{R\theta(X-a)(R\theta-b)}{R} - N_2 \frac{X(X-a)(R\theta-b)}{R}$$

$$h_{20,2} = N_2 \frac{R\theta(X-a)^2(R\theta-b)}{R^2}$$

$$h_{21,2} = N_{12} \frac{R\theta(X-a)(R\theta-b)}{R} + N_2 \frac{(X-a)^2(R\theta-b)}{R}$$

$$h_{3,3} = N_1(R\theta-b)^2 + 2N_{12}(X-a)(R\theta-b) + N_2(X-a)^2$$

$$h_{8,3} = N_{12} \frac{X(R\theta-b)^2}{R} + N_2 \frac{X(X-a)(R\theta-b)}{R}$$

$$h_{9,3} = -N_1(R\theta-b)^2 - N_{12} [(X-a)(R\theta-b) + X(R\theta-b)] - N_2(X-a)$$

$$h_{14,3} = -N_{12} \frac{XR\theta(R\theta-b)}{R} - N_2 \frac{R\theta(X-a)}{R}$$

TABLE B-1 (Continued)

$$h_{15,3} = -N_1 R\theta(R\theta-b) + N_{12} [R\theta(X-a) + X(R\theta-b)] + N_2 X(X-a)$$

$$h_{20,3} = N_{12} \frac{R\theta(X-a)(R\theta-b)}{R} + N_2 \frac{R\theta(X-a)^2}{R}$$

$$h_{21,3} = -N_1 R\theta(R\theta-b) - N_{12} [(X-a)^2 - (X-a)(R\theta-b)] - N_2 (X-a)^2$$

$$h_{8,8} = N_2 \frac{X^2(R\theta-b)^2}{R^2}$$

$$h_{9,8} = -N_{12} \frac{X(R\theta-b)^2}{R} - N_2 \frac{X^2(R\theta-b)}{R}$$

$$h_{14,8} = -N_2 \frac{X^2 R\theta(R\theta-b)}{R^2}$$

$$h_{15,8} = N_{12} \frac{XR\theta(R\theta-b)}{R} + N_2 \frac{X^2(R\theta-b)}{R}$$

$$h_{20,8} = N_2 \frac{XR\theta(X-a)(R\theta-b)}{R^2}$$

$$h_{21,8} = -N_{12} \frac{XR\theta(R\theta-b)}{R} - N_2 \frac{X(X-a)(R\theta-b)}{R}$$

$$h_{9,9} = N_1 (R\theta-b)^2 + N_{12} (R\theta-b)(X-a) + N_2 X^2$$

$$h_{14,9} = N_{12} \frac{XR\theta(R\theta-b)}{R} + N_2 \frac{X^2 R\theta}{R}$$

$$h_{15,9} = -N_1 (R\theta)(R\theta-b) - N_{12} X[R\theta + (R\theta-b)] - N_2 X^2$$

TABLE B-1 (Concluded)

$$h_{20,9} = -N_{12} \frac{R\theta(X-a)(R\theta-b)}{R} - N_2 \frac{R\theta X(X-a)}{R}$$

$$h_{21,9} = N_1 R\theta(R\theta-b) + N_2 [XR\theta + (X-a)(R\theta-b)] + N_2 X(X-a)$$

$$h_{14,14} = N_2 \frac{(R\theta)^2 X^2}{R^2}$$

$$h_{20,14} = -N_2 \frac{X(R\theta)^2(X-a)}{R^2}$$

$$h_{15,14} = -N_{12} \frac{X(R\theta)^2}{R} - N_2 \frac{X^2 R\theta}{R}$$

$$h_{21,14} = N_{12} \frac{X(R\theta)^2}{R} + N_2 \frac{XR\theta(X-a)}{R}$$

$$h_{15,15} = N_1 (R\theta)^2 + 2N_{12} XR\theta + N_2 X^2$$

$$h_{20,15} = N_{12} \frac{(R\theta)^2(X-a)}{R} + N_2 \frac{R\theta X(X-a)}{R}$$

$$h_{21,15} = -N_1 (R\theta)^2 - N_{12} [XR\theta + R\theta(X-a)] - N_2 X(X-a)$$

$$h_{20,20} = N_2 \frac{(R\theta)^2(X-a)^2}{R^2}$$

$$h_{21,20} = -N_{12} \frac{(R\theta)^2(X-a)}{R} - N_2 \frac{R\theta(X-a)}{R}$$

$$h_{21,21} = N_1 (R\theta)^2 + 2N_{12} R\theta(X-a) + N_2 (X-a)^2$$

TABLE B-2 Elements of  $[G]^T[\hat{K}^2][G]$ 

$$e_{2,1} = + \frac{C_{51}}{R} (X-a)(R\theta-b)^2 + \frac{C_{53}}{R} (X-a)^2(R\theta-b)$$

$$e_{3,1} = - (R\theta-b)[C_{21}(R\theta-b)+C_{51}(X-a)] - (X-a)[C_{23}(R\theta-b)+C_{53}(X-a)]$$

$$e_{8,1} = - \frac{C_{51}}{R} X(R\theta-b)^2 - \frac{C_{53}}{R} X(X-a)(R\theta-b)$$

$$e_{9,1} = (R\theta-b)[C_{21}(R\theta-b)+C_{51}X] + (X-a)[C_{23}(R\theta-b) + C_{53}X]$$

$$e_{14,1} = + \frac{C_{51}}{R} XR\theta(R\theta-b) + \frac{C_{53}}{R} XR\theta(X-a)$$

$$e_{15,1} = -(R\theta-b)[C_{21}R\theta+C_{51}X] - (X-a)[C_{23}R\theta+C_{53}X]$$

$$e_{20,1} = - \frac{C_{51}}{R} R\theta(X-a)(R\theta-b) - \frac{C_{53}}{R} R\theta(X-a)^2$$

$$e_{21,1} = (R\theta-b)[C_{21}R\theta+C_{51}(X-a)] + (X-a)[C_{23}R\theta+C_{53}(X-a)]$$

$$e_{2,2} = \frac{C_{53}}{R} (X-a)(R\theta-b)^2 + \frac{C_{54}}{R} (X-a)^2(R\theta-b)$$

$$+ \frac{1}{R} (X-a)(R\theta-b)[C_{35}(R\theta-b) + C_{45}(X-a) + \frac{C_{55}}{R} (X-a)(R\theta-b)]$$

$$e_{3,2} = -(R\theta-b)[C_{23}(R\theta-b) + C_{53}(X-a)] - (X-a)[C_{24}(R\theta-b)+C_{54}(X-a)]$$

$$+ \frac{1}{R}(X-a)(R\theta-b)[-C_{25}(R\theta-b) + \frac{C_{45}}{R} (X-a)(R\theta-b) - C_{55}(X-a)]$$

TABLE B-2 (Continued)

$$e_{7,2} = -\frac{C_{51}}{R}(X-a)(R\theta-b)^2 - C_{53} \frac{X}{R} (X-a)(R\theta-b)$$

$$e_{8,2} = -\frac{C_{53}X}{R} (R\theta-b)^2 - \frac{C_{54}X}{R} (X-a)(R\theta-b) \\ - \frac{1}{R} (X-a)(R\theta-b) [C_{35}(R\theta-b) + C_{45}X + C_{55} \frac{X}{R} (R\theta-b)]$$

$$e_{9,2} = (R\theta-b) [C_{23}(R\theta-b) + C_{53}X] + (X-a) [C_{24}(R\theta-b) + C_{54}X] \\ + \frac{1}{R} (X-a)(R\theta-b) [C_{25}(R\theta-b) - C_{45} \frac{X}{R} (R\theta-b) + C_{55}X]$$

$$e_{13,2} = C_{51} \frac{\theta R}{R} (X-a)(R\theta-b) + C_{53} \frac{X}{R} (X-a)(R\theta-b)$$

$$e_{14,2} = C_{53} \frac{XR\theta}{R} (R\theta-b) + C_{54} \frac{XR\theta}{R} (X-a) + \frac{1}{R} (X-a)(R\theta-b) [C_{35}R\theta + C_{45}X + C_{55} \frac{XR\theta}{R}]$$

$$e_{15,2} = -(R\theta-b) [C_{23}R\theta + C_{53}X] - (X-a) [C_{24}R\theta + C_{54}X] \\ + \frac{1}{R} (X-a)(R\theta-b) [-C_{25}R + C_{45} \frac{XR\theta}{R} - C_{55}X]$$

$$e_{19,2} = -C_{51} \frac{R\theta}{R} (X-a)(R\theta-b) - \frac{C_{53}}{R} (X-a)^2 (R\theta-b)$$

$$e_{20,2} = -C_{53} \frac{R\theta}{R} (X-a)(R\theta-b) - C_{54} \frac{R\theta}{R} (X-a)^2 \\ - \frac{1}{R} (X-a)(R\theta-b) [C_{35}R\theta + C_{45}(X-a) + C_{55} \frac{R\theta}{R} (X-a)]$$



TABLE B-2 (Continued)

$$e_{21,2} = (R\theta-b) [C_{23}R\theta + C_{53}(X-a)] + (X-a) [C_{24}R\theta + C_{54}(X-a)] \\ + \frac{1}{R} (X-a)(R\theta-b) [C_{25}R\theta - C_{45} \frac{\theta R}{R} (X-a) + C_{55}(X-a)]$$

$$e_{3,3} = C_{22}(R\theta-b)^2 - C_{42} \frac{1}{R} (X-a)(R\theta-b)^2 + C_{52}(X-a)(R\theta-b) - C_{24} \frac{1}{R} (X-a)(R\theta-b)^2 \\ - \frac{C_{54}}{R} (X-a)^2(R\theta-b) + C_{25}(X-a)(R\theta-b) - \frac{C_{45}}{R} (X-a)^2(R\theta-b) + C_{55}(X-a)^2$$

$$e_{7,3} = (R\theta-b) [C_{21}(R\theta-b) + C_{51}(X-a)] + [C_{23}(R\theta-b) + C_{53}(X-a)]$$

$$e_{8,3} = C_{23}(R\theta-b)^2 + C_{53}(X-a)(R\theta-b) + C_{24} X(R\theta-b) + C_{54} X(X-a) \\ + C_{25} \frac{X}{R} (R\theta-b)^2 - C_{45} \frac{X}{R^2} (X-a)(R\theta-b)^2 + C_{55} \frac{X}{R} (X-a)(R\theta-b)$$

$$e_{9,3} = -C_{22}(R\theta-b)^2 + C_{42} \frac{X}{R} (R\theta-b)^2 - C_{52}X(R\theta-b) + \frac{C_{24}}{R} (X-a)(R\theta-b)^2 \\ + C_{54} \frac{X}{R} (X-a)(R\theta-b) - C_{25}(X-a)(R\theta-b) + C_{45} \frac{X}{R} (X-a)(R\theta-b) - C_{55}X(X-a)$$

$$e_{13,3} = -C_{21}R\theta(R\theta-b) - C_{51}R\theta(X-a) - C_{23} X(R\theta-b) - C_{53} X(X-a)$$

$$e_{14,3} = -C_{23} R\theta(R\theta-b) - C_{53}R\theta(X-a) - C_{24}X(R\theta-b) - C_{54}X(X-a) \\ + \frac{XR\theta}{R} [-C_{25}(R\theta-b) + C_{45} \frac{1}{R} (X-a)(R\theta-b) - C_{55}(X-a)]$$

TABLE B-2 (Continued)

$$e_{15,3} = C_{22}R\theta(R\theta-b) - C_{42} \frac{XR\theta}{R} (R\theta-b) + C_{52}X(R\theta-b) - C_{24} \frac{R\theta}{R} (X-a)(R\theta-b)$$

$$-C_{54} \frac{X}{R} (X-a)(R\theta-b) + C_{25}R\theta(X-a) - C_{45} \frac{XR\theta}{R} (X-a) + C_{55}X(X-a)$$

$$e_{19,3} = C_{21}R\theta(R\theta-b) + C_{51}R\theta(X-a) + (X-a)[C_{23}(R\theta-b) + C_{53}(X-a)]$$

$$e_{20,3} = C_{23}R\theta(R-b) + C_{53}R\theta(X-a) + C_{24}(X-a)(R\theta-b) + C_{54}(X-a)^2$$

$$+ C_{25} \frac{R\theta}{R} (X-a)(R\theta-b) - C_{45} \frac{R\theta}{R} (X-a)^2(R\theta-b) + C_{55} \frac{R\theta}{R} (X-a)^2$$

$$e_{21,3} = -C_{22}R\theta(R\theta-b) + C_{42} \frac{R\theta}{R} (X-a)(R\theta-b) - C_{52}(X-a)(R\theta-b) + C_{24} \frac{R\theta}{R} (X-a)(R\theta-b)$$

$$+ \frac{C_{54}}{12} (X-a)^2(R\theta-b) - C_{25}R\theta(X-a) + C_{45} \frac{R\theta}{R} (X-a)^2 - C_{55}(X-a)^2$$

$$e_{8,7} = \frac{C_{51}}{R} X(R\theta-b)^2 + C_{53} \frac{X^2}{R} (R\theta-b)$$

$$e_{9,7} = -(R\theta-b)[C_{21}(R\theta-b) + C_{51}X] - X[C_{23}(R\theta-b) + C_{53}X]$$

$$e_{14,7} = -C_{51} \frac{X\theta R}{R} (R\theta-b) - C_{53} \frac{X^2\theta R}{R}$$

$$e_{15,7} = (R\theta-b)[C_{21}R\theta + C_{51}X] + X[C_{23}R\theta + C_{53}X]$$

$$e_{20,7} = C_{51} \frac{\theta R}{R} (X-a)(R\theta-b) + C_{53} \frac{R\theta X}{R} (X-a)$$

$$e_{21,7} = -(R\theta-b)[C_{21}R\theta + C_{51}(X-a)] - X[C_{23}R\theta + C_{53}(X-a)]$$

TABLE B-2 (Continued)

$$e_{8,8} = C_{53} \frac{X}{R} (R\theta-b)^2 + C_{54} \frac{X^2}{R} (R\theta-b) + C_{35} \frac{X}{R} (R\theta-b)^2$$

$$+ C_{45} \frac{X^2}{R} (R\theta-b) + C_{55} \frac{X^2}{R^2} (R\theta-b)^2$$

$$e_{9,8} = -C_{23}(R\theta-b)^2 - C_{53}X(R\theta-b) - C_{24}X(R\theta-b) - C_{54}X^2 - C_{25} \frac{X}{R} (R\theta-b)^2$$

$$+ C_{45} \frac{X^2}{R^2} (R\theta-b)^2 - C_{55} \frac{X^2}{R} (R\theta-b)$$

$$e_{13,8} = -C_{51} \frac{XR\theta}{R} (R\theta-b) - C_{53} \frac{X^2}{R} (R\theta-b)$$

$$e_{14,8} = -C_{53} \frac{XR\theta}{R} (R\theta-b) - C_{54} \frac{X^2R\theta}{R} - C_{35} \frac{XR\theta}{R} (R\theta-b)$$

$$- C_{45} \frac{X^2}{R} (R\theta-b) - C_{55} \frac{X^2R\theta}{R^2} (R\theta-b)$$

$$e_{15,8} = C_{23}R (R\theta-b) + C_{53}X(R\theta-b) + C_{24}R\theta X + C_{54}X^2 + C_{25} \frac{XR\theta}{R} (R\theta-b)$$

$$- C_{45} \frac{X^2R\theta}{R^2} (R\theta-b) + C_{55} \frac{X^2}{R} (R\theta-b)$$

$$e_{19,8} = C_{51} \frac{XR\theta}{R} (R\theta-b) + C_{53} \frac{X}{R} (X-a)(R\theta-b)$$

$$e_{20,8} = C_{53} \frac{R\theta}{R} (X-a)(R\theta-b) + C_{54} \frac{XR\theta}{R} (X-a) + C_{35} \frac{XR\theta}{R} (R\theta-b)$$

$$+ C_{45} \frac{X}{R} (X-a)(R\theta-b) + C_{55} \frac{XR\theta}{R^2} (X-a)(R\theta-b)$$

TABLE B-2 (Continued)

$$e_{21,8} = -C_{23}R\theta(R\theta-b) - C_{53}(X-a)(R\theta-b) - C_{24}XR\theta - C_{54}X(X-a)$$

$$-C_{25} \frac{XR\theta}{R} (R\theta-b) + C_{45} \frac{XR\theta}{R^2} (X-a)(R\theta-b) - C_{55} \frac{X}{R} (X-a)(R\theta-b)$$

$$e_{9,9} = C_{22}(R\theta-b)^2 - C_{42} \frac{X}{R} (R\theta-b)^2 + C_{52}X(R\theta-b) - C_{24} \frac{X}{R} (R\theta-b)^2$$

$$-C_{54} \frac{X^2}{R} (R\theta-b) + C_{25}X(R\theta-b) - C_{45} \frac{X^2}{R} (R\theta-b) + C_{55}X^2$$

$$e_{13,9} = C_{21}R\theta(R\theta-b) + C_{51}R\theta X + C_{23}X(R\theta-b) + C_{53}X^2$$

$$e_{14,9} = C_{23}R\theta(R\theta-b) + C_{53}XR\theta + C_{24}X(R\theta-b) + C_{54}X^2 + C_{25} \frac{XR\theta}{R} (R\theta-b)$$

$$-C_{45} \frac{X^2R\theta}{R^2} (R\theta-b) + C_{55} \frac{X^2R\theta}{R}$$

$$e_{15,9} = -C_{22}R (R\theta-b) + C_{42} \frac{XR\theta}{R} (R\theta-b) - C_{52} X(R\theta-b) + C_{24} \frac{XR\theta}{R} (R\theta-b)$$

$$+C_{54} \frac{X^2}{R} (R\theta-b) - C_{25}XR\theta + C_{45} \frac{X^2R\theta}{R} - C_{55}X^2$$

$$e_{19,9} = -C_{21}R\theta(R\theta-b) - C_{51}X\theta R - (X-a)[C_{23}(R\theta-b) + C_{53}X]$$

$$e_{20,9} = -C_{23}R\theta(R\theta-b) - C_{53}XR\theta - C_{24}(X-a)(R\theta-b) - C_{54}X(X-a)$$

$$-C_{25} \frac{R\theta}{R} (X-a)(R\theta-b) + C_{45} \frac{XR\theta}{R^2} (X-a)(R\theta-b) - C_{55} \frac{XR\theta}{R} (X-a)$$

TABLE B-2 (Continued)

$$e_{21,9} = C_{22}R\theta(R\theta-b) - C_{42} \frac{R\theta}{R} (X-a)(R\theta-b) + C_{52} (X-a)(R\theta-b) - C_{24} \frac{XR\theta}{R} (R\theta-b)$$

$$-C_{54} \frac{X}{R} (X-a)(R\theta-b) + C_{25}XR\theta - C_{45} \frac{XR\theta}{R} (X-a) + C_{55}X(X-a)$$

$$e_{14,13} = C_{51} \frac{XR^2\theta^2}{R} + C_{53} \frac{X^2\theta R}{R}$$

$$e_{15,13} = -C_{21}R^2\theta^2 - C_{51}XR\theta - C_{23}XR\theta - C_{53}X^2$$

$$e_{20,13} = -C_{51} \frac{R^2\theta^2}{R} (X-a) - C_{53} \frac{X\theta R}{R} (X-a)$$

$$e_{21,13} = C_{21}R^2\theta^2 + C_{51}(X-a)R\theta + C_{23}XR\theta + C_{53}X(X-a)$$

$$e_{14,14} = C_{53} \frac{XR^2\theta^2}{R} + C_{54} \frac{X^2R\theta}{R} + C_{35} \frac{XR^2\theta^2}{R} + C_{45} \frac{X^2R\theta}{R} + C_{55} \frac{X^2R^2\theta^2}{R^2}$$

$$e_{15,14} = -C_{23}R^2\theta^2 - C_{53}XR\theta - C_{24}XR\theta - C_{54}X^2 - C_{25} \frac{XR^2\theta^2}{R}$$

$$e_{19,14} = -C_{51} \frac{XR^2\theta^2}{R} - C_{53} \frac{XR\theta}{R} (X-a)$$

$$e_{20,14} = -C_{53} \frac{R^2\theta^2}{R} (X-a) - C_{54} \frac{XR\theta}{R} (X-a) - C_{35} \frac{XR^2\theta^2}{R} - C_{45} \frac{XR\theta}{R} (X-a)$$

$$-C_{55} \frac{XR^2\theta^2}{R^2} (X-a)$$

TABLE B-2 (Continued)

$$e_{21,14} = C_{23}R^2\theta^2 + C_{53}R\theta(X-a) + C_{24}XR\theta + C_{54}X(X-a) + C_{25}\frac{XR^2\theta^2}{R}$$

$$- C_{45}\frac{XR^2\theta^2}{R^2}(X-a) + C_{55}\frac{XR\theta}{R}(X-a)$$

$$e_{15,15} = C_{22}R^2\theta^2 - C_{42}\frac{XR^2\theta^2}{R} + C_{52}XR\theta - C_{24}\frac{XR^2\theta^2}{R} - C_{54}\frac{X^2R\theta}{R} + C_{25}XR\theta$$

$$- C_{45}\frac{X^2R\theta}{R} + C_{55}X^2$$

$$e_{19,15} = C_{21}R^2\theta^2 + C_{51}R\theta X + (X-a)[C_{23}R\theta + C_{53}X]$$

$$e_{20,15} = C_{23}R^2\theta^2 + C_{53}XR\theta + C_{24}R\theta(X-a) + C_{54}X(X-a) + C_{25}\frac{R^2\theta^2}{R}(X-a)$$

$$- C_{45}\frac{XR^2\theta^2}{R^2}(X-a) + C_{55}\frac{XR\theta}{R}(X-a)$$

$$e_{21,15} = -C_{22}R^2\theta^2 + C_{42}\frac{R^2\theta^2}{R}(X-a) - C_{52}R\theta(X-a) + C_{24}\frac{XR^2\theta^2}{R}$$

$$+ C_{54}\frac{XR\theta}{R}(X-a) - C_{25}XR\theta + C_{45}\frac{XR\theta}{R}(X-a) - C_{55}X(X-a)$$

$$e_{20,19} = C_{51}\frac{R^2\theta^2}{R}(X-a) + C_{53}\frac{R\theta}{R}(X-a)^2$$

$$e_{21,19} = -C_{21}R^2\theta^2 - C_{51}R\theta(X-a) - (X-a)[C_{23}R\theta + C_{53}(X-a)]$$

$$e_{20,20} = C_{53}\frac{R^2\theta^2}{R}(X-a) + C_{54}\frac{R\theta}{R}(X-a)^2 + C_{35}\frac{R^2\theta^2}{R}(X-a) + C_{45}\frac{R\theta}{R}(X-a)^2$$

$$+ C_{55}\frac{R^2\theta^2}{R^2}(X-a)^2$$

TABLE B-2 (Concluded)

$$e_{21,20} = -C_{23}R^2\theta^2 - C_{53}R\theta(X-a) - C_{24}R\theta(X-a) - C_{54}(X-a)^2 - C_{25}\frac{R^2\theta^2}{R}(X-a) \\ + C_{45}\frac{R^2\theta^2}{R^2}(X-a)^2 - C_{55}\frac{R\theta}{R}(X-a)^2$$

$$e_{21,21} = C_{22}R^2\theta^2 - C_{42}\frac{R^2\theta^2}{R}(X-a) + C_{52}R\theta(X-a) - C_{24}\frac{R^2\theta^2}{R}(X-a) - C_{54}\frac{R\theta}{R}(X-a)^2 \\ + C_{25}R\theta(X-a) - C_{45}\frac{R\theta}{R}(X-a)^2 + C_{55}(X-a)^2$$

where:

$$C_{21} = \beta_1; C_{51} = \nu\beta_2; C_{22} = \beta_1^2 + \frac{(1-\nu)}{2}\beta_2^2$$

$$C_{32} = \frac{1-\nu}{2}\beta_2; C_{42} = \nu\beta_1; C_{52} = \frac{1+\nu}{2}\beta_1\beta_2$$

$$C_{54} = \frac{1-\nu}{2}\beta_1; C_{55} = \beta_2^2 + \frac{(1-\nu)}{2}\beta_1^2$$

## CHAPTER XII

APPENDIX C - COMPUTER PROGRAM LISTING

The computer program used to obtain the results presented in Chapter V is presented in detail in this Appendix. This program is called STABL. The input data required are as follows;

NC	number of cases to be run
$N\phi$	number of finite elements
$N\phi DE$	number of nodes
NE	number of degrees of freedom to be constrained
AZ(MN)	length of the finite element, MN, in the X-direction
BZ(MN)	length of the finite element, MN, in the $\theta$ -direction
CZ(MN)	curvature of the finite element, MN
EZ(MN)	modulus of elasticity of finite element, MN
TZ(MN)	thickness of finite element, MN
XMUZ(MN)	Poisson's ratio for finite element, MN
$N1(MN), N2(MN)$	the four mode points of finite element MN, read counter clockwise, with N1 and N2 estab- lishing the element X-axis
$N3(MN), N4(MN)$	
JR(I)	a list of the degrees of freedom to be restrained
$F\phi RC(I,1)$	the vector of applied forces

A listing of the program follows. Comment cards are included in the listing to provide clarifications of program functioning and terminology.



```
OVERLAY(LINK,0,0),
PROGRAM STABL (INPUT,OUTPUT,TAPE2,TAPE3)
COMMON/ZZ1/AZ(30),BZ(30),CZ(30),DMZ(30),DBZ(30),XMUZ(30)
1 /ZZ2/XK0(24,24)
2 /ZZ3/N1(50),N2(50),N3(50),N4(50)
4 /ZZ5/JR(150)
5 /ZZ6/FORC(216,1)
6 /ZZ7/X(216)
7 /ZZ8/S(3,24),
8 /ZZ9/STRSR(3),
9 /ZZ10/XK1(24,24),
9 /ZZ11/XE(24)
9 /ZZ12/BTA1,BTA2
9 /ZZ13/XK2(24,24)
9 /ZZ14/S0
LINK=4LINK,
READ 1000,NC,S0
1000 FORMAT (I3,E12.4)
NOC=0
1001 CALL OVERLAY(LINK,1,0,0),
CALL OVERLAY(LINK,2,0,0),
NOC=NOC+1
IF(NOC.LT.NC) GO TO 1001
STOP
END,
OVERLAY(LINK,1,0),
COMMON/ZZ1/AZ(30),BZ(30),CZ(30),DMZ(30),DBZ(30),XMUZ(30)
1 /ZZ2/XK0(24,24)
2 /ZZ3/N1(50),N2(50),N3(50),N4(50)
4 /ZZ5/JR(150)
5 /ZZ6/FORC(216,1)
6 /ZZ7/X(216)
7 /ZZ8/S(3,24),
8 /ZZ9/STRSR(3),
9 /ZZ10/XK1(24,24),
9 /ZZ11/XE(24)
9 /ZZ12/BTA1,BTA2
9 /ZZ13/XK2(24,24)
9 /ZZ14/S0
DIMENSION IPIVOT(216),XMK(216,216),INDEX(216,2),EZ(30),TZ(30),
C A IS LEN. IN X DIR, B IS LEN. IN THETA DIR, C IS CURVATURE,XMU IS
C POISSONS RATIO, XK0 IS THE ELEM STIFF. MATRIX.
C NO=NUMBER OF ELEMENTS
C NODE=NUMBER OF NODES
```

```
C      IF SQ=0, BETA SQRD TERMS ARE IGNORED, IF SQ=1, BETA SQRD TRMS USED
C      NE=NUMBER OF DOF TO BE RESTRAINED
1001 READ 101,NO,NODE,NE
101  FORMAT (3I3)
      JDOF=6*NODE
C      INITIALIZE MASTER STIFFNESS MATRIX, XMK, TO ZERO
      DO 51 II=1,JDOF
      DO 51 JJ=1,JDOF
      XMK(II,JJ)=0.0
51  CONTINUE
      DO 1 MN=1,NO
      READ 105,AZ(MN),BZ(MN),CZ(MN),EZ(MN),TZ(MN),XMUZ(MN)
105  FORMAT(6E12.4)
      DMZ(MN)=EZ(MN)*TZ(MN)/(1.-XMUZ(MN)**2)
      DBZ(MN)=DMZ(MN)*TZ(MN)**2/12.
C      READ THE NODE NOS IN COUNTER CLOCKWISE DIR. FOR ELEM. MN
      READ 109,N1(MN),N2(MN),N3(MN),N4(MN)
109  FORMAT (4I3)
      PRINT 53,MN
53  FORMAT (/40X,*ELEMENT NUMBER*,I3)
      PRINT 54,AZ(MN),BZ(MN),CZ(MN),EZ(MN),TZ(MN),N1(MN),N2(MN),N3(MN),
1N4(MN)
54  FORMAT (/1X,*A=*,E12.4,*B=*,E12.4,*C=*,E12.4,*E=*,E12.4,*T=*,E12.4
1,*N1=*,I3,*N2=*,I3,*N3=*,I3,*N4=*,I3)
      CALL ELEMKO (MN)
      CALL ADDUP (MN,XMK,XK0)
1  CONTINUE
C      READ IN THE D.O.F. TO BE ELIMINATED, JR(NE)
      READ 121,(JR(I),I=1,NE)
121  FORMAT (25I3)
      PRINT 55
55  FORMAT (/40X,*DEGREES OF FREEDOM TO BE ELIMINATED*)
      PRINT 121,(JR(I),I=1,NE)
C      ELIMINATE NE DEGREES OF FREEDOM FROM XMK(I,J) TO OBTAIN THE
C      REDUCED MASTER STIFF MATRIX WHICH WILL STILL BE CALLED XMK BUT IS
C      OF ORDER JDOF-NE
      CALL WASH (JDOF,NE,XMK)
      JDOFR=JDOF-NE
C      ZERO OUT APPLIED FORCE VECTOR
      DO 3 I=1,216
      FORC(I,1)=0.0
3  CONTINUE
C      READ IN APPLIED FORCES
      READ 2,(FORC(I,1),I=1,JDOF)
```

```
2 FORMAT (6E12.4)
C   REDUCE FORCE VECTOR TO CORRESPOND TO RED. MASTER STIFF. MATRIX
   CALL REDFORC (JDOF,NE),
C   PRINT REDUCED FORCE VECTOR, STILL CALLING IT FORC
   PRINT 133
133 FORMAT (/40X,*FORCES APPLIED TO UNRESTRAINED D.O.F**/)
   PRINT 137,(I,FORC(I,1),I=1,JDOFR)
137 FORMAT ( 4X,*FORC(*,13,*)=*,E12.4)
C   SOLVE FOR DISPLACEMENTS
   CALL MATINV (XMK,JDOFR,FORC,1,DETERM,PIVOT,INDEX,216,ISCALE)
C   XMK-INVERSE IS NOW STORED IN XMK
C   NAME DISPLACEMENTS. AT THIS POINT THEY ARE STORED IN FORC
   DO 5 I=1,JDOFR
     X(I)=FORC(I,1)
5 CONTINUE
C   REORDER DISPLACEMENTS TO AGREE WITH NODE NUMBERING
   CALL EXPDEF (JDOF,NE),
C   PRINT OUT DISPLACEMENTS
   PRINT 141
   PRINT 145,(I,X(I),I=1,JDOF)
   REWIND 2,
   WRITE TAPE 2,(( XMK(I,J),I=1,180),J=1,180),NO,JDOF,NE,JDOFR,
141 FORMAT (/50X,*DISPLACEMENTS*/)
145 FORMAT ( 4X,*X(*,13,*)=*,E12.4)
C   DEVELOP THE STRESS MATRIX FOR EACH ELEMENT AND COMPUTE THE,
C   INPLANE STRESS RESULTANTS AT THE CENTER OF THE ELEMENT,
   DO 13 I=1,216
     DO 13 J=1,216
13 XMK(I,J)=0.
     DO 11 MN=1,NO,
       CALL STRESS (MN),
C       COMPUTE THE ELEMENT PRESTRESS MATRIX,XK1
       CALL ELEMK1(MN),
C       COMBINE ELEMENT XK1 MATRACIES IN TO A MASTER PRESTRESS MATRIX
       CALL ADDUP (MN,XMK,XK1)
C       COMPUTE ELEMENT PREBUCKLING DEFORMATION MATRIX
       CALL ELEMK2 (MN)
C       COMBINE ELEMENT XK2 MATRACIES INTO A MASTER K2 MATRIX
       CALL ADDUP(MN,XMK,XK2),
11 CONTINUE,
C   THE MASTER K1 MATRIX IS IN XMK
C   REDUCE XMK1 TO PROPER ORDER
   CALL WASH (JDOF,NE,XMK)
   REWIND 3
```

WRITE TAPE 3,((XMK(I,J),I=1,JDOFR),J=1,JDOFR)

RETURN,

END.

SUBROUTINE ELEMKO (MN)

COMMON/ZZ1/AZ(30),BZ(30),CZ(30),DMZ(30),DBZ(30),XMUZ(30)

1 /ZZ2/XK0(24,24)

2 /ZZ3/N1(50),N2(50),N3(50),N4(50)

A=AZ(MN)

B=BZ(MN)

C=CZ(MN)

DM=DMZ(MN)

DB=DBZ(MN)

XMU=XMUZ(MN)

AB=A/B

BA=B/A

ATB=A\*B

AB3=A/B\*\*3

BA3=B/A\*\*3

XK0(1,1)=XK0(7,7)=XK0(13,13)=XK0(19,19)=DM\*(BA/3.+AB\*(1.-XMU)/6.)

XK0(2,1)=XK0(14,13)=XK0(20,7)=XK0(19,8)=DM\*(1.+XMU)/8.

XK0(3,1)=XK0(9,1)=XK0(19,15)=XK0(21,19)=-7.\*XMU\*B\*DM\*C/40.

XK0(4,1)=XK0(10,7)=XK0(16,13)=XK0(22,19)=XK0(3,1)\*A/6.

XK0(5,1)=XK0(11,1)=XK0(17,13)=XK0(23,13)=-B\*\*2\*XMU\*DM\*C/40.

XK0(6,1)=XK0(12,7)=XK0(24,13)=XK0(19,18)=XK0(5,1)\*A/6.

XK0(7,1)=XK0(19,13)=-DM\*(BA/3.-(1.-XMU)\*AB/12.)

XK0(8,1)=XK0(19,2)=XK0(14,7)=XK0(20,13)=-DM\*(1.-3.\*XMU)/8.

XK0(10,1)=XK0(22,13)=XK0(19,16)=XK0(7,4)=-XK0(4,1)

XK0(12,1)=XK0(7,6)=XK0(18,13)=XK0(24,19)=-XK0(6,1)

XK0(13,1)=XK0(19,7)=-XK0(1,1)/2.

XK0(14,1)=XK0(13,2)=XK0(8,7)=XK0(20,19)=-XK0(2,1)

XK0(15,1)=XK0(21,1)=XK0(19,3)=XK0(19,9)=-3.\*XMU\*B\*DM\*C/40.

XK0(16,1)=XK0(13,4)=XK0(22,7)=XK0(19,10)=ATB\*XMU\*DM\*C/80.

XK0(17,1)=XK0(23,1)=XK0(13,11)=XK0(13,5)=B\*\*2\*XMU\*DM\*C/60.

XK0(18,1)=XK0(19,6)=XK0(24,7)=XK0(13,12)=XK0(5,1)\*A/9.

XK0(19,1)=XK0(13,7)=DM\*(BA/6.-(1.-XMU)\*AB/6.)

XK0(20,1)=XK0(7,2)=XK0(13,8)=XK0(19,14)=-XK0(8,1)

XK0(22,1)=XK0(19,4)=XK0(16,7)=XK0(13,10)=-XK0(16,1)

XK0(24,1)=XK0(13,6)=XK0(18,7)=XK0(19,12)=-XK0(18,1)

XK0(2,2)=XK0(8,8)=XK0(14,14)=XK0(20,20)=DM\*((AB/3.)\*(1.+DB\*(C\*\*2)/

DM)+((1.-XMU)\*BA/6.)\*(1.+4.\*DB\*(C\*\*2)/DM)

XK0(3,2)=XK0(9,8)=-7.\*A\*DM\*C/40.+DB\*(2.-3.\*XMU)\*C/(2.\*A)

XK0(4,2)=XK0(22,2)=XK0(14,10)=XK0(16,14)=-A\*\*2\*DM\*C/40.-XMU\*DB\*C/

12.

XK0(5,2)=XK0(11,8)=XK0(17,14)=XK0(23,20)=-7.\*ATB\*DM\*C/240.-DB\*C\*(

$1(2.-XMU)*B/(12.*A)+7.*AB/20.)$   
 $XK0(6,2)=XK0(18,8)=XK0(14,12)=XK0(24,20)=-A*ATB*DM*C/240.-DB*C*($   
 $1XMU*B/12.+A*AB/20.)$   
 $XK0(8,2)=XK0(20,14)=DM*(AB/6.*(1.+DB*C**2/DM)-(1.-XMU)*BA/6.*(1.+$   
 $14.*DB*C**2/DM))$   
 $XK0(9,2)=XK0(8,3)=-3.*A*DM*C/40.-(2.-3.*XMU)*DB*C/(2.*A)$   
 $XK0(10,2)=XK0(16,2)=XK0(14,4)=XK0(22,14)=DM*A**2*C/60.$   
 $XK0(11,2)=XK0(8,5)=XK0(23,14)=XK0(20,17)=-ATB*DM*C/80.+DB*C*(2.-$   
 $1XMU)*BA/12.-3.*AB/20.)$   
 $XK0(12,2)=XK0(14,6)=XK0(24,8)=XK0(20,18)=A*ATB*DM*C/360.+A*AB*DB$   
 $1*C/30.$   
 $XK0(14,2)=XK0(20,8)=-XK0(2,2)/2.$   
 $XK0(15,2)=XK0(21,8)=-3.*A*DM*C/40.+(2.-XMU)*DB*C/(2.*A)$   
 $XK0(17,2)=XK0(14,5)=XK0(23,8)=XK0(20,11)=-XK0(11,2)$   
 $XK0(18,2)=XK0(8,6)=XK0(20,12)=XK0(24,14)=-XK0(12,2)$   
 $XK0(20,2)=XK0(14,8)=-DM*(AB/3.*(1.+DB*C**2/DM)-BA*(1.-XMU)/12.*(1.$   
 $1+4.*DB*C**2/DM))$   
 $XK0(21,2)=XK0(15,8)=-7.*A*DM*C/40.-(2.-XMU)*DB*C/(2.*A)$   
 $XK0(23,2)=XK0(20,5)=XK0(17,8)=XK0(14,11)=-XK0(5,2)$   
 $XK0(24,2)=XK0(20,6)=XK0(12,8)=XK0(18,14)=-XK0(6,2)$   
 $XK0(3,3)=XK0(9,9)=XK0(15,15)=XK0(21,21)=156./35.*DB*(B/A**3+A/$   
 $1B**3)+72./25.*DB/ATB+169.*ATB*DM*C**2/1225.$   
 $XK0(4,3)=XK0(22,21)=A*(DB*(78./35.*B/A**3+22./35.*A/B**3+1./ATB*($   
 $16./25.+6.*XMU/5.))+143.*ATB*DM*C**2/(6.*1225.))$   
 $XK0(5,3)=XK0(11,9)=B*(DB*(22.*B/(35.*A**3)+78.*A/(35.*B**3)+1./$   
 $1ATB*(6./25.+6.*XMU/5.))+143.*ATB*DM*C**2/(6.*1225.))$   
 $XK0(6,3)=XK0(18,15)=A*B*(DB*(11.*B/(35.*A**3)+11./35.*A/B**3+$   
 $11./ATB*(.02+.2*XMU))+121.*ATB*DM*C**2/(36.*1225.))$   
 $XK0(7,3)=XK0(9,7)=XK0(15,13)=XK0(21,13)=-XK0(3,1)$   
 $XK0(9,3)=XK0(21,15)=-DB*(156./35.*B/A**3-54./35.*A/B**3+72./25.*$   
 $1ATB))+117.*ATB*DM*C**2/(2.*1225.)$   
 $XK0(10,3)=XK0(21,16)=A*(DB*(78./35.*B/A**3-13./35.*A/B**3+6./$   
 $125.*ATB))-169.*ATB*DM*C**2/(12.*1225.))$   
 $XK0(11,3)=XK0(9,5)=B*(DB*(-22./35.*B/A**3+27./35.*A/B**3-1./ATB*$   
 $1(6./25.+6.*XMU/5.))+33.*ATB*DM*C**2/(4.*1225.))$   
 $XK0(12,3)=XK0(24,15)=A*B*(DB*(11./35.*B/A**3-13./70.*A/B**3+1./$   
 $1ATB*(.02+XMU*.1))-143.*ATB*DM*C**2/(72.*1225.))$   
 $XK0(13,3)=XK0(15,7)=XK0(21,7)=XK0(13,9)=-XK0(15,1)$   
 $XK0(14,3)=XK0(20,9)=-XK0(15,2)$   
 $XK0(15,3)=XK0(21,9)=-54./35.*DB*(B/A**3+A/B**3)+72./25.*DB/ATB+$   
 $181.*ATB*DM*C**2/(4.*1225.)$   
 $XK0(16,3)=XK0(21,10)=A*(DB*(27./35.*B/A**3+13./35.*A/B**3-6./$   
 $1(25.*ATB))-39.*ATB*DM*C**2/(8.*1225.))$   
 $XK0(17,3)=XK0(23,9)=B*(DB*(13./35.*B/A**3+27./35.*A/B**3-6./$

```
1 (25.*ATB))-39.*ATB*DM*C**2/(8.*1225.))
XK0(18,3)=XK0(15,6)= A*B*(DB*(-13./70.*(BA3+AB3)+.02/ATB)+169.*
1 ATB*DM*C**2/(144.*1225.))
XK0(20,3)=XK0(14,9)=-XK0(21,2)
XK0(21,3)=XK0(15,9)= DB*(54./35.*BA3-156./35.*AB3-72./(25.*ATB))
1 +117.*ATB*DM*C**2/(2.*1225)
XK0(22,3)=XK0(21,4)= A*(DB*(27./35.*BA3-22./35.*AB3-1./ATB*(6./25.
1 +6.*XMU/5.))+33.*ATB*DM*C**2/(4.*1225.))
XK0(23,3)=XK0(17,9)= B*(DB*(-13./35.*BA3+78./35.*AB3+6./(25.*ATB))
1 -169.*ATB*DM*C**2/(12.*1225.))
XK0(24,3)=XK0(15,12)= A*B*(DB*(-13./70.*BA3+11./35.*AB3+1./ATB*
1 (.02+.1*XMU))-143.*ATB*DM*C**2/(72.*1225.))
XK0(4,4)=XK0(10,10)=XK0(16,16)=XK0(22,22)= A**2*(DB*(52./35.*BA3
1 +4./35.*AB3+8./(25.*ATB))+13.*ATB*DM*C**2/(3.*1225.))
XK0(5,4)=XK0(17,16)= A*B*(DB*(11./35.*(BA3+AB3)+1./ATB*(.02+1.2*
1 XMU))+121.*ATB*DM*C**2/(36.*1225.))
XK0(6,4)=XK0(12,10)= A**2*B*(DB*(22./105.*BA3+2./35.*AB3+2./ATB*
1 (1./75.+XMU/15.))+11.*ATB*DM*C**2/(18.*1225.))
XK0(8,4)=XK0(22,8)=XK0(20,10)=XK0(20,16)=-XK0(10,2)
XK0(9,4)=XK0(22,15)=-XK0(10,3)
XK0(10,4)=XK0(22,16)= A**2*(DB*(26./35.*BA3-3./35.*AB3-2./(25.*ATB
1 ))-13.*ATB*DM*C**2/(4.*1225.))
XK0(11,4)=XK0(23,16)= A*B*(DB*(-11./35.*BA3+13./70.*AB3-1./ATB*(
1 .02+.1*XMU))+143.*ATB*DM*C**2/(72.*1225.))
XK0(12,4)=XK0(10,6)= A**2*B*(DB*(11./105.*BA3-3./70.*AB3-1./ATB*
1 (1./150.+XMU/30.))-11.*ATB*DM*C**2/(24.*1225.))
XK0(15,4)=XK0(22,9)=-XK0(16,3)
XK0(16,4)=XK0(22,10)= A**2*(DB*(9./35.*BA3+3./35.*AB3+2./(25.*ATB)
1 )-9.*ATB*DM*C**2/(8.*1225.))
XK0(17,4)=XK0(16,5)= A*B*(DB*(13./70.*(BA3+AB3)-.02/ATB)-169.*ATB
1 *DM*C**2/(144.*1225.))
XK0(18,4)=XK0(24,10)= A**2*B*(DB*(-13./210.*BA3- 3./70.*AB3-1./
1 (150.*ATB))+13.*ATB*DM*C**2/(48.*1225.))
XK0(20,4)=XK0(10,8)=XK0(16,8)=XK0(22,20)=-XK0(4,2)
XK0(22,4)=XK0(16,10)= A**2*(DB*(18./35.*BA3-4./35.*AB3-8./(25.*
1 ATB))+3.*ATB*DM*C**2/(2.*1225.))
XK0(23,4)=XK0(16,11)= A*B*(DB*(-13./70.*BA3+11./35.*AB3+1./ATB*
1 (.02+.1*XMU))-143.*ATB*DM*C**2/(72.*1225.))
XK0(24,4)=XK0(18,10)= A**2*B*(DB*(-13./105.*BA3+2./35.*AB3+2./
1 75.*ATB))-13.*ATB*DM*C**2/(36.*1225.))
XK0(5,5)=XK0(11,11)=XK0(17,17)=XK0(23,23)= B**2*(DB*(4./35.*BA3
1 +52./35.*AB3+8./(25.*ATB))+13.*ATB*DM*C**2/(3.*1225.))
XK0(6,5)=XK0(24,23)= A*B**2*(DB*(2./35.*BA3+22./105.*AB3+2./ATB*
1 (1./75.+XMU/15.))+11.*ATB*DM*C**2/(18.*1225.))
```

XK0(7,5)=XK0(11,7)=XK0(23,19)=XK0(19,17)=-XK0(5,1)  
XK0(10,5)=XK0(22,17)=-XK0(11,4)  
XK0(11,5)=XK0(23,17)= B\*\*2\*(DB\*(-4./35.\*BA3+18./35.\*AB3-8./25.\*  
1 ATB))+3.\*ATB\*DM\*C\*\*2/(2.\*1225.)  
XK0(12,5)=XK0(23,18)= A\*\*2\*(DB\*(2./35.\*BA3-13./105.\*AB3+2./  
1 75.\*ATB))-13.\*ATB\*DM\*C\*\*2/(36.\*1225.)  
XK0(15,5)=XK0(21,11)=-XK0(17,3)  
XK0(17,5)=XK0(23,11)= B\*\*2\*(DB\*(3./35.\*BA3+9./35.\*AB3+2./25.\*ATB)  
1 )-9.\*ATB\*DM\*C\*\*2/(8.\*1225.)  
XK0(18,5)=XK0(23,12)= A\*\*2\*(DB\*(-3./70.\*BA3-13./210.\*AB3-1./  
1 (150.\*ATB))+13.\*ATB\*DM\*C\*\*2/(48.\*1225.)  
XK0(19,5)=XK0(17,7)=XK0(23,7)=XK0(19,11)=-XK0(17,1)  
XK0(21,5)=XK0(15,11)=-XK0(23,3)  
XK0(22,5)=XK0(17,10)=-XK0(23,4)  
XK0(23,5)=XK0(17,11)= B\*\*2\*(DB\*(-3./35.\*BA3+26./35.\*AB3-2./25.\*  
1 ATB))-13.\*ATB\*DM\*C\*\*2/(4.\*1225.)  
XK0(24,5)=XK0(23,6)= A\*\*2\*(DB\*(-3./70.\*BA3+11./105.\*AB3-1./ATB\*  
1 (1./150.+XMU/30.))-11.\*ATB\*DM\*C\*\*2/(24.\*1225.)  
XK0(6,6)=XK0(12,12)=XK0(18,18)=XK0(24,24)=A\*\*2\*B\*\*2\*(DB\*(4./105.\*(  
1 BA3+AB3))+8./225.\*ATB))+ATB\*DM\*C\*\*2/(9.\*1225.)  
XK0(9,6)=XK0(21,18)=-XK0(12,3)  
XK0(11,6)=XK0(24,17)=-XK0(12,5)  
XK0(12,6)=XK0(24,18)= A\*\*2\*B\*\*2\*(DB\*(2./105.\*BA3-1./35.\* AB3-2./  
1 (225.\*ATB))-ATB\*DM\*C\*\*2/(12.\*1225.)  
XK0(16,6)=XK0(22,12)=-XK0(18,4)  
XK0(17,6)=XK0(24,11)=-XK0(18,5)  
XK0(18,6)=XK0(24,12)= A\*\*2\*B\*\*2\*(DB\*(-1./70.\*(BA3+AB3)+1./450.\*  
1 ATB))+ATB\*DM\*C\*\*2/(16.\*1225.)  
XK0(21,6)=XK0(18,9)=-XK0(24,3)  
XK0(22,6)=XK0(16,12)=-XK0(24,4)  
XK0(24,6)=XK0(18,12)= A\*\*2\*B\*\*2\*(DB\*(-1./35.\*BA3+2./105.\*AB3-2./  
1 (225.\*ATB))-ATB\*DM\*C\*\*2/(12.\*1225.)  
XK0(10,9)=XK0(16,15)=-XK0(4,3)  
XK0(12,9)=XK0(24,21)=-XK0(6,3)  
XK0(16,9)=XK0(15,10)=-XK0(22,3)  
XK0(24,9)=XK0(21,12)=-XK0(18,3)  
XK0(11,10)=XK0(23,22)=-XK0(5,4)  
XK0(23,10)=XK0(22,11)=-XK0(17,4)  
XK0(12,11)=XK0(18,17)=-XK0(6,5)  
XK0(18,11)=XK0(17,12)=-XK0(24,5)  
XK0(15,14)=XK0(21,20)=-XK0(3,2)  
XK0(17,15)=XK0(23,21)=-XK0(5,3)  
XK0(20,15)=XK0(21,14)=-XK0(9,2)  
XK0(23,15)=XK0(21,17)=-XK0(11,3)

```
XK0(18,16)=XK0(24,22)=-XK0(6,4)
XK0(24,16)=XK0(22,18)=-XK0(12,4)
C MAKE USE OF SYMMETRY TO COMPLETE THE MATRIX
DO 5 J=1,24 ,
K=J ,
DO 5 I=K,24 ,
IF(I,EQ,J) GO TO 5 ,
XK0(J,I)=XK0(I,J) ,
5 CONTINUE ,
RETURN ,
END ,
SUBROUTINE REDFORC(JDOF,NE),
COMMON/ZZ5/JR(150)
5 /ZZ6/FORC(216,1)
C THIS SUBROUTINE ELIMINATES FORCES AT REACTIONS
DO 43 IN=1,NE
LL=JR(IN)-IN+1
LEF=JDOF-1
DO 43 N=LL,LEF
FORC(N,1)=FORC(N+1,1),
43 CONTINUE
RETURN
END
SUBROUTINE ADDUP (MN,XMK,XK0)
COMMON/ZZ3/N1(50),N2(50),N3(50),N4(50)
DIMENSION XMK(216,216),XK0(24,24)
L1=N1(MN) ,
L2=N2(MN) ,
L3=N3(MN) ,
L4=N4(MN) ,
DO 4 I=1,4 ,
DO 4 J=1,4 ,
NI=6*L1-5 ,
NJ=6*L1-5 ,
IF(I,EQ,2) NI=6*L2-5 ,
IF(J,EQ,2) NJ=6*L2-5 ,
IF(I,EQ,3) NI=6*L3-5 ,
IF(J,EQ,3) NJ=6*L3-5 ,
IF(I,EQ,4) NI=6*L4-5 ,
IF(J,EQ,4) NJ=6*L4-5 ,
DO 4 KI=1,6 ,
DO 4 KJ=1,6 ,
KKI=NI+KI-1 ,
KKJ=NJ+KJ-1 ,
```



```
KXI=6*I-6+KI
KXJ=6*J-6+KJ
XMK(KKI,KKJ)=XMK(KKI,KKJ)+XK0(KXI,KXJ)
IF((KKI.EQ.27).AND.(KKJ.EQ.28)) 2,4
2 PRINT 3,XMK(KKI,KKJ)
3 FORMAT (/40X,E20.4/)
4 CONTINUE
RETURN
END
SUBROUTINE WASH (JD0F,NE,XMK)
COMMON/ZZ5/JR(150)
DIMENSION XMK(216,216)
C SET DESIRED ROWS AND COLS TO ZERO
DO 31 N=1,NE
LL=JR(N)
DO 31 I=1,JD0F
XMK(LL,I)=0.0
XMK(I,LL)=0.0
31 CONTINUE
C COMPACT MATRIX
DO 33 IN=1,NE
LL=JR(IN)-IN+1
LEF=JD0F-1
DO 33 N=LL,LEF
DO 32 I=1,JD0F
XMK(N,I)=XMK(N+1,I)
32 CONTINUE
DO 33 I=1,JD0F
XMK(I,N)=XMK(I,N+1)
33 CONTINUE
RETURN
END
SUBROUTINE EXPDEF (JD0F,NE)
COMMON/ZZ5/JR(150)
7 /ZZ7/X(216)
C THE PURPOSE OF THIS SUBROUTINE IS TO ARRANGE THE DISPLACEMENTS IN
C THE ORDER OF THE NODE NUMBERING
DO 201 IN=1,NE
LF=JD0F-JR(IN)
DO 201 N=1,LF
X(JD0F-N+1)=X(JD0F-N)
201 CONTINUE
DO 203 II=1,NE
LL=JR(II)
```

```
X(LL)=0.0.  
203 CONTINUE  
RETURN  
END
```

```
SUBROUTINE STRESS (MN),  
COMMON/ZZ1/AZ(30),BZ(30),CZ(30),DMZ(30),DBZ(30),XMUZ(30)  
2 /ZZ3/N1(50),N2(50),N3(50),N4(50)  
6 /ZZ7/X(216)  
7 /ZZ8/S(3,24),  
8 /ZZ9/STRSR(3),  
9 /ZZ11/XE(24)  
9 /ZZ12/BTA1,STA2
```

```
C THIS SUBROUTINE COMPUTES THE STRESS MATRIX, S . THE MULTIPLIES IT,  
C BY THE DISPLACEMENT VECTOR FOR THE ELEMENT.,  
C COMPUTE EACH TERM OF THE ELEMENT STRESS MATRIX.
```

```
A=AZ(MN)  
B=BZ(MN)  
C=CZ(MN)  
DM=DMZ(MN)  
DB=DBZ(MN)  
XMU=XMUZ(MN)  
S(1,1)=S(1,19)=-DM/(2.*A),  
S(1,2)=S(1,8)=-XMU*DM/(2.*B),  
S(1,3)=S(1,9)=S(1,15)=S(1,21)=XMU*DM*C/4.,  
S(1,4)=S(1,22)=A*S(1,3)/4.,  
S(1,5)=S(1,11)=B*S(1,3)/4.,  
S(1,6)=S(1,18)=A*B*S(1,3)/16.,  
S(1,7)=S(1,13)=-S(1,1),  
S(1,10)=S(1,16)=-S(1,4),  
S(1,12)=S(1,24)=-S(1,6),  
S(1,14)=S(1,20)=-S(1,2),  
S(1,17)=S(1,23)=-S(1,5),  
S(2,1)=S(2,19)=XMU*S(1,1),  
S(2,2)=S(2,8)=-DM/(2.*B),  
S(2,3)=S(2,9)=S(2,15)=S(2,21)=DM*C/4.,  
S(2,4)=S(2,22)=A*S(2,3)/4.,  
S(2,5)=S(2,11)=B*S(2,3)/4.,  
S(2,6)=S(2,18)=A*B*S(2,3)/16.,  
S(2,7)=S(2,13)=-S(2,1),  
S(2,10)=S(2,16)=-S(2,4),  
S(2,12)=S(2,24)=-S(2,6),  
S(2,14)=S(2,20)=-S(2,2),  
S(2,17)=S(2,23)=-S(2,5),  
S(3,1)=S(3,7)=- (1.-XMU)*DM/(4.*B),
```

```
S(3,2)=S(3,20)=-((1.-XMU)*DM/(4.*A),
S(3,8)=S(3,14)=-S(3,2),
S(3,13)=S(3,19)=-S(3,1),
S(3,3)=S(3,4)=S(3,5)=S(3,6)=S(3,9)=S(3,10)=S(3,11)=S(3,12)=S(3,15),
I=S(3,16)=S(3,17)=S(3,18)=S(3,21)=S(3,22)=S(3,23)=S(3,24)=0.0,
C PRINT OUT ELEMENT STRESS MATRIX,
PRINT 751, MN,
751 FORMAT (40X,*ELEMENT STRESS MATRIX FOR ELEMENT NO *,I3/),
PRINT 753,((S(I,J),J=1,24),I=1,3),
753 FORMAT (6E20,4),
C CONSTRUCT THE DISPLACEMENT VECTOR FOR THIS ELEMENT,
DO 700 IE=1,24,
IF(I.E.GE.7) GO TO 703,
ND1=6*(NI(MN)-1),
XE(IF)=X(ND1+IE),
GO TO 700,
703 IF(IF.GE.13) GO TO 705,
ND2=6*(N2(MN)-1),
XE(IF)=X(ND2+IE-6),
GO TO 700,
705 IF(IF.GE.19) GO TO 707,
ND3=6*(N3(MN)-1),
XE(IF)=X(ND3+IE-12),
GO TO 700,
707 ND4=6*(N4(MN)-1),
XE(IF)=X(ND4+IE-18),
700 CONTINUE,
PRINT 709, MN,
709 FORMAT(/40X,*DISPLACEMENT VECTOR FOR ELEMENT NO *,I3/),
PRINT 711,(XE(I),I=1,24),
711 FORMAT (4X,E20,4),
BTA1=(XE(3)-XE(9)+XE(21)-XE(15))/(2*A)
BTA2=(XE(3)-XE(21)+XE(9)-XE(15))/(2.*B)+C*(XE(2)+XE(8)+XE(14)+XE(2
10))/4.
PRINT 720
720 FORMAT(/40X,*AVERAGE ROTATIONS ABOUT Y AND X AXES*/),
PRINT 722,BTA1,BTA2
722 FORMAT (40X,E20,4)
C MULTIPLY STRESS MATRIX BY THE DISPLACEMENT VECTOR TO OBTAIN THE,
C INPLANE STRESS RESULTANTS,ENX,ENY AND ENXY,
CALL MATRIX(20,3,24,1,S,3,XE,24,STRSR,3),
PRINT 713,MN,
713 FORMAT(/40X,*STRESS RESULTANTS FOR ELEMENT NO*,I3/),
PRINT 715,(I,STRSR (I),I=1,3),
```

```
715 FORMAT (4X,*STRSR(*,I3,*)=*,E12.4),
      RETURN,
      END,
      SUBROUTINE ELEMK1 (MN),
      COMMON/ZZ1/AZ(30),BZ(30),CZ(30),DMZ(30),DBZ(30),XMUZ(30)
8      /ZZ9/STRSR(3),
9      /ZZ10/XK1(24,24),
      A=AZ(MN)
      B=BZ(MN)
      C=CZ(MN)
      DM=DMZ(MN)
      DB=DBZ(MN)
      XMU=XMUZ(MN)
C      ZERO OUT XK1,
      DO 900 I=1,24,
      DO 900 J=1,24,
      XK1(I,J)=0.0,
900 CONTINUE,
      S1=STRSR(1),
      S2 =STRSR(2),
      S12=STRSR(3),
      XK1(2,2)=XK1(8,8)=XK1(14,14)=XK1(20,20)=S2*A*B*C**2/9.,
      XK1(3,3)=XK1(15,15)=S1*B/(3.*A)+S12/2.+S2*A/(3.*B),
      XK1(9,9)=XK1(21,21)=S1*B/(3.*A)-S12/2.+S2*A/(3.*B),
      XK1(3,2)=XK1(2,3)=(S12*B+S2*A)*C/6.,
      XK1(8,2)=XK1(2,8)=S2*A*B*C**2/18.,
      XK1(9,2)=XK1(2,9)=- (S12*B-S2*A/2.)*C/6.,
      XK1(14,2)=XK1(2,14)=XK1(2,2)/4.,
      XK1(15,2)=XK1(2,15)=-XK1(3,2)/2.,
      XK1(20,2)=XK1(2,20)=XK1(14,8)=XK1(8,14)=XK1(20,14)=XK1(14,20)=,
1     XK1(2,2)/2.,
      XK1(21,2)=XK1(2,21)=(S12*B/2.-S2*A)*C/6.,
      XK1(8,3)=XK1(3,8)=(S12*B+S2*A/2.)*C/6.,
      XK1(9,3)=XK1(3,9)=-S1*B/(3.*A)+S2*A/(6.*B),
      XK1(14,3)=XK1(3,14)=-XK1(15,2),
      XK1(15,3)=XK1(3,15)=-S1*B/(6.*A)-S12/2.-S2*A/(6.*B),
      XK1(20,3)=XK1(3,20)=(S12*B/2.+S2*A)*C/6.,
      XK1(21,3)=XK1(3,21)=S1*B/(6.*A)-S2*A/(3.*B),
      XK1(9,8)=XK1(8,9)=- (S12*B-S2*A)*C/6.,
      XK1(15,8)=XK1(8,15)=- (S12/2.*B+S2*A)*C/6.,
      XK1(20,8)=XK1(8,20)=XK1(2,2)/4.,
      XK1(21,8)=XK1(8,21)=(S12*B-S2*A)*C/12.,
      XK1(14,9)=XK1(9,14)=-XK1(21,2),
      XK1(15,9)=XK1(9,15)=XK1(21,3),
```

```
XK1(20,9)=XK1(9,20)=XK1(9,8)/2.,
XK1(21,9)=XK1(9,21)=-S1*B/(6.*A)+S12/2.-S2*A/(6.*B),
XK1(20,15)=XK1(15,20)=- (S12*B+S2*A/2.)*C/6.,
XK1(21,14)=XK1(14,21)=-XK1(9,2),
XK1(15,14)=XK1(14,15)=-XK1(3,2),
XK1(21,15)=XK1(15,21)=-S1*B/(3.*A)+S2*A/(6.*B),
XK1(21,20)=XK1(20,21)=-XK1(3,2),
RETURN.
```

END.

SUBROUTINE ELEMK2 (MN)

COMMON/ZZ1/AZ(30),BZ(30),CZ(30),DMZ(30),DBZ(30),XMUZ(30)

9 /ZZ12/BTA1,BTA2

9 /ZZ13/XK2(24,24)

9 /ZZ14/SO

A=AZ(MN)

B=BZ(MN)

C=CZ(MN)

DM=DMZ(MN)

DB=DBZ(MN)

XMU=XMUZ(MN)

C ZERO OUT XK2(I,J)

DO 950 I=1,24

DO 950 J=1,24

XK2(I,J)=0.0

950 CONTINUE

C DEFINE CONSTANTS

C1=1.0-XMU

C2=1.0+XMU

C3=1.0-3.0\*XMU

C DEFINE SECOND ORDER TERMS. A MODULATING FACTOR, SO, WILL DETERMINE

C WHEATHER THE SECOND ORDER TERMS WILL BE USED OR NOT

ALF1=SO\*(BTA1\*\*2+C1\*BTA2\*\*2/2.0)

ALF2=SO\*(BTA2\*\*2+C1\*BTA1\*\*2/2.0)

ALF3=SO\*C2\*BTA1\*BTA2

XK2(2,1)=XK2(1,2)=-C\*(.5\*C1\*A\*BTA1+XMU\*B\*BTA2)/6.0

XK2(3,1)=XK2(1,3)=- (.5\*C1\*A1B+B/A)\*BTA1/3.-C2\*BTA2/8.0

XK2(8,1)=XK2(1,8)=-C\*(.25\*C1\*A\*BTA1+XMU\*B\*BTA2)/6.0

XK2(9,1)=XK2(1,9)=- (.25\*C1\*A/B-B/A)\*BTA1/3.0+C3\*BTA2/8.0

XK2(14,1)=XK2(1,14)=.5\*XK2(2,1)

XK2(15,1)=XK2(1,15)= (.5\*C1\*A/B+B/A)\*BTA1/6.0+C2\*BTA2/8.

XK2(20,1)=XK2(1,20)=-C\*(C1\*A\*BTA1+XMU\*B\*BTA2)/12.

XK2(21,1)=XK2(1,21)=(C1\*A/B-B/A)\*BTA1/6.-C3\*BTA2/8.

XK2(2,2)=-C\*(.5\*C1\*B\*BTA1+A\*BTA2)/3.+A\*B\*C\*\*2\*ALF2/9.

XK2(3,2)=XK2(2,3)=-C2\*BTA1/8.- (.5\*C1\*B/A+A/B)\*BTA2/3.+C\*(.5\*B\*ALF3

$1 + A * ALF2 / 6 + C ** 2 * A * B * BTA2 / 9$   
 $XK2(7,2) = XK2(2,7) = -C * (.25 * C1 * A * BTA1 - XMU * B * BTA2) / 6$   
 $XK2(8,2) = XK2(2,8) = -A * BTA1 * C / 6 + A * B * C ** 2 * ALF2 / 18$   
 $XK2(9,2) = XK2(2,9) = -C3 * BTA1 / 8 + (C1 * B / A - A / B) * BTA2 / 6 - C * (B * ALF3 - A * ALF2) / 12 + A * B * BTA2 * C ** 2 / 18$   
 $XK2(13,2) = XK2(2,13) = C * (.5 * C1 * A * BTA1 + XMU * B * BTA2) / 12$   
 $XK2(14,2) = XK2(2,14) = A * B * ALF2 * C ** 2 / 36$   
 $XK2(15,2) = XK2(2,15) = C2 * BTA1 / 8 + (.5 * C1 * B / A + A / B) * BTA2 / 6 - C * (.5 * B * ALF3 + A * ALF2) / 12 + A * B * BTA2 * C ** 2 / 36$   
 $XK2(19,2) = XK2(2,19) = C * (C1 * A * BTA1 - XMU * B * BTA2) / 12$   
 $XK2(20,2) = XK2(2,20) = -C1 * B * BTA1 * C / 12 + 5 * A * B * ALF2 * C ** 2 / 36$   
 $XK2(21,2) = XK2(2,21) = C2 * BTA1 / 8 - (C1 * B / (4 * A) - A / B) * BTA2 / 3 + C * (.25 * B * ALF3 - A * ALF2) / 6 + 5 * A * B * BTA2 * C ** 2 / 36$   
 $XK2(3,3) = C * (XMU * B * BTA1 + A * BTA2) / 3 + ALF3 / 4 + B * ALF1 / (A * 3) + A * ALF2 / (B * 13)$   
 $XK2(7,3) = XK2(3,7) = -(C1 * A / (4 * B) - B / A) * BTA1 / 3 - C3 * BTA2 / 8$   
 $XK2(8,3) = XK2(3,8) = C3 * BTA1 / 8 + (C1 * B / A - A / B) * BTA2 / 6 + C * (B * ALF3 + A * ALF2) / 12 + A * B * BTA2 * C ** 2 / 18$   
 $XK2(9,3) = XK2(3,9) = A * BTA2 * C / 6 - B * ALF1 / (3 * A) + A * ALF2 / (6 * B)$   
 $XK2(13,3) = XK2(3,13) = XK2(15,1)$   
 $XK2(14,3) = XK2(3,14) = C2 * BTA1 / 8 + (.5 * C1 * B / A + A / B) * BTA2 / 6 + C * (.5 * B * ALF3) / 12 + A * B * BTA2 * C ** 2 / 36$   
 $XK2(15,3) = XK2(3,15) = -ALF3 / 4 - B * ALF1 / (6 * A) - A * ALF2 / (6 * B)$   
 $XK2(19,3) = XK2(3,19) = (C1 * A / B - B / A) * BTA1 / 6 + C3 * BTA2 / 8$   
 $XK2(20,3) = XK2(3,19) = -C3 * BTA1 / 8 - (.25 * C1 * B / A) * BTA2 / 3 + C * (.25 * B * ALF3 + A * ALF2) / 6 + 5 * A * B * BTA2 * C ** 2 / 36$   
 $XK2(21,3) = XK2(3,21) = XMU * B * BTA1 * C / 6 + B * ALF1 / (6 * A) - A * ALF2 / (3 * B)$   
 $XK2(8,7) = XK2(7,8) = -C * (C1 * A * BTA1 / 2 - XMU * B * BTA2) / 6$   
 $XK2(9,7) = XK2(7,9) = -(C2 * A / (2 * B) + B / A) * BTA1 / 3 + C2 * BTA2 / 8$   
 $XK2(14,7) = XK2(7,14) = -XK2(19,2)$   
 $XK2(15,7) = XK2(7,15) = XK2(19,3)$   
 $XK2(20,7) = XK2(7,20) = XK2(8,7) / 2$   
 $XK2(21,7) = XK2(7,21) = XK2(9,7)$   
 $XK2(8,8) = C * (C1 * B * BTA1 / 2 - A * BTA2) / 3 + A * B * ALF2 * C ** 2 / 9$   
 $XK2(9,8) = XK2(8,9) = C2 * BTA1 / 8 - (.5 * C1 * B / A + A / B) * BTA2 / 3 - C * (.5 * B * ALF3 - A * ALF2) / 6 + A * B * BTA2 * C ** 2 / 9$   
 $XK2(13,8) = XK2(8,13) = -XK2(20,1)$   
 $XK2(14,8) = XK2(8,14) = C1 * B * BTA1 * C / 12 + A * B * ALF2 * C ** 2 / 18$   
 $XK2(15,8) = XK2(8,15) = -C3 * BTA1 / 8 - (.25 * C1 * B / A - A / B) * BTA2 / 3 - C * (B * ALF3) / 4 + A * ALF2 / 6 + A * B * BTA2 * C ** 2 / 18$   
 $XK2(19,8) = XK2(8,19) = -.5 * XK2(8,7)$   
 $XK2(20,8) = XK2(8,20) = XK2(8,2)$   
 $XK2(21,8) = XK2(8,21) = -C2 * BTA1 / 8 + (.5 * C1 * B / A + A / B) * BTA2 / 6 + C * (.5 * B * ALF3 / 2 - A * ALF2) / 12 + A * B * BTA2 * C ** 2 / 36$

```
XK2(9,9)=-C*(XMU*B*BTA1-A*BTA2)/3.+ALF3/4.+B*ALF1/(3.*A)+A*ALF2/(
13.*B)
XK2(13,9)=XK2(9,13)=XK2(21,1)
XK2(14,9)=XK2(9,14)=C3*BTA1/8.-(.25*C1*B/A-A/B)*BTA2/3.-C*(.25*B*
1ALF3-A*ALF2)/6.+A*B*BTA2*C**2/18.
XK2(15,9)=XK2(9,15)=-XMU*B*BTA1*C/6.+B*ALF1/(6.*A)-A*ALF2/(3.*B)
XK2(19,9)=XK2(9,19)=XK2(21,7)
XK2(20,9)=XK2(9,20)=-C2*BTA1/8.+(.5*C1*B/A+A/B)*BTA2/6.-C*(B*ALF3/
12.-A*ALF2)/12.+A*B*BTA2*C**2/36.
XK2(21,9)=XK2(9,21)=ALF3/4.-B*ALF1/(6.*A)-A*ALF2/(6.*B)
XK2(14,13)=XK2(13,14)=-.5*XK2(14,1)
XK2(15,13)=XK2(13,15)=XK2(3,1)
XK2(20,13)=XK2(13,20)=-XK2(8,1)
XK2(21,13)=XK2(13,21)=XK2(9,1)
XK2(14,14)=C*(.5*C1*B*BTA1+A*BTA2)/3.+A*B*ALF2*C**2/9.
XK2(15,14)=XK2(14,15)=-C2*BTA1/8.-(.5*C1*B/A+A/B)*BTA2/3.-C*(.5*B*
1ALF3+A*ALF2)/6.+A*B*BTA2*C**2/9.
XK2(19,14)=XK2(14,19)=-XK2(7,2)
XK2(20,14)=XK2(14,20)=A*BTA2*C/6.+A*B*ALF2*C**2/18.
XK2(21,14)=XK2(14,21)=-C3*BTA1/8.+(C1*B/A-A/B)*BTA2/6.+C*(B*ALF3-
1A*ALF2)/12.+A*B*BTA2*C**2/18.
XK2(15,15)=-C*(XMU*B*BTA1+A*BTA2)/3.+ALF3/4.+B*ALF1/(3.*A)+A*ALF2/
1(3.*B)
XK2(19,15)=XK2(15,19)=XK2(7,3)
XK2(20,15)=XK2(15,20)=C3*BTA1/8.+(C1*B/A-A/B)*BTA2/6.-C*(B*ALF3+A*
1ALF2)/12.+A*B*BTA2*C**2/18.
XK2(21,15)=XK2(15,21)=-A*BTA2*C/6.-B*ALF1/(3.*A)+A*ALF2/(6.*B)
XK2(20,19)=XK2(19,20)=-XK2(8,7)
XK2(21,19)=XK2(19,21)=XK2(9,7)
XK2(20,20)=-C*(.5*C1*B*BTA1-A*BTA2)/3.+A*B*ALF2*C**2/9.
XK2(21,20)=XK2(20,21)=XK2(9,8)
XK2(21,21)=C*(XMU*B*BTA1-A*BTA2)/3.-ALF3/4.+B*ALF1/(3.*A)+A*ALF2/
1(3.*B)
DO 960 I=1,24
DO 960 J=1,24
XK2(I,J)=DM*XK2(I,J)
960 CONTINUE
RETURN
END
OVERLAY(LINK,2,0).
COMMON/ZZ1/AZ(30),BZ(30),CZ(30),DMZ(30),DBZ(30),XMUZ(30)
1 /ZZ2/XK0(24,24)
2 /ZZ3/N1(50),N2(50),N3(50),N4(50)
4 /ZZ5/JR(150)
```

```
5      /ZZ6/FORC(216,1)
6      /ZZ7/X(216)
7      /ZZ8/S(3,24),
8      /ZZ9/STRSR(3),
9      /ZZ10/XK1(24,24),
9      /ZZ11/XE(24)
9      /ZZ12/BTA1,BTA2
9      /ZZ13/XK2(24,24)
9      /ZZ14/SO
      DIMENSION XMK(180,180),XMK2(180,180),
      IRTR(180),RTI(180),IRUN(180),P(180),NDEX(180)
      REWIND 2,
      READ TAPE 2,((XMK2(I,J),I=1,180),J=1,180),NO,JDOF,NE,JDOFR,
C      ADD XMK1 AND XMK2 AND STORE IN XMK
      REWIND 3,
      READ TAPE 3,((XMK(I,J),I=1,JDOFR),J=1,JDOFR)
C      MULT THE MATRIX (XMK1+XMK2) BY XMK-INVERSE
      CALL MATRIX (20,JDOFR,JDOFR,JDOFR,XMK2,180,XMK,180,XMK,180)
C      GET EIGEN VALUES FOR BUKL
      NPLUS=JDOFR+1
      CALL REIG(XMK,JDOFR,3,3,RTR,RTI,XMK,180,NDEX,IRUN,P,NPLUS,XMK2)
      PRINT 171
171  FORMAT (/45X,*EIGEN VALUES*/)
      PRINT 173,(RTR(I),I=1,3)
173  FORMAT (3E20,4)
      RETURN,
      END
```