

General Disclaimer

One or more of the Following Statements may affect this Document

- This document has been reproduced from the best copy furnished by the organizational source. It is being released in the interest of making available as much information as possible.
- This document may contain data, which exceeds the sheet parameters. It was furnished in this condition by the organizational source and is the best copy available.
- This document may contain tone-on-tone or color graphs, charts and/or pictures, which have been reproduced in black and white.
- This document is paginated as submitted by the original source.
- Portions of this document are not fully legible due to the historical nature of some of the material. However, it is the best reproduction available from the original submission.

(NASA-CR-138165) CHEMILUMINESCENT
MEASUREMENT OF ATMOSPHERIC ACID Final
Report (Michigan Univ.) 41 p HC \$5.25

N74-22281

CSCCL 04A

Unclas
G3/20 37856

THE UNIVERSITY OF MICHIGAN

COLLEGE OF ENGINEERING

Department of Atmospheric and Oceanic Science and the
Space Physics Research Laboratory
of the Department of Electrical and Computer Engineering

Final Report

CHEMILUMINESCENT MEASUREMENT OF ATMOSPHERIC ACID

Prepared on behalf of the project by

D. H. STEDMAN

and

G. L. KOK

for

National Aeronautics and Space Administration
Langley Research Center
Hampton, Virginia 23365

under Grant No. NGR23-005-599 entitled
"Determination of 0.1-10 ppm HCl in Air"

6 May 1974

This report summarizes the work done under NASA Langley Grant No. NGR23--005-599. The purpose of this work was the design and construction of a gas phase acid sensitive analyzer. Part I describes the laboratory work which was done on the various components of the system. These studies showed that the chemical system was a practical analytical method. A complete instrument was developed and prepared for field testing.

A Titan III-C rocket was scheduled for launching on February 11, 1974. Through preparations made by NASA Langley our instrument was set up to monitor the acid concentration in the rocket exhaust. Due to adverse wind conditions no acid was detected. Part II describes this entire trip in detail.

The entire instrument was left with the NASA for further evaluation. Since the nitric oxide analyzer was on loan from the Thermoelectron Corporation it could not be retained by the Langley group and was returned to the University of Michigan. To provide the NASA group with a piece of hardware for evaluation purposes another acid analyzer was constructed in our laboratories. This instrument was based on the same principals as the previous model. The operating instructions and construction details are described in Appendix I. This instrument was delivered to NASA Langley on April 18, 1974.

A paper describing the instrumentation and the results obtained from it has been submitted for publication in Analytical Chemistry. A copy of this paper is attached as Appendix II.

PART I

CHEMILUMINESCENT MEASUREMENT OF ATMOSPHERIC ACID

AND

PRELIMINARY STUDIES

FIRST INSTRUMENT

An inlet system has been developed for a commercially available NO detector to enable measurement of total (gas and aerosol) atmospheric acid, or gaseous atmospheric acid only. The instrument used was a Thermoelectron Model 12A. It has a full scale sensitivity of a 1ppm on its most sensitive scale. The NO detector is self contained in a compact package and the acid selective inlet system mounts directly on top of the thermoelectron case. The system has capabilities of measuring acids in the 0-10ppm and 0-1ppm range. The inlet system consists of two main parts, the sampling valves and the high temperature convertor to convert the ammonia to nitric oxide.

The principal of operation is the reaction of hydrogen chloride aerosol or gas with ammonia, and the conversion of the remaining ammonia to nitric oxide. The nitric oxide is then detected using the chemiluminescent detector. The net acid concentration is measured as the difference in the ammonia signal. This method has been shown feasible by the preliminary study of Dzubay et al.¹

A diagram of the system is shown in Figure 1. The sample flow into the thermoelectron is split into two streams, a small air flow over the ammonia permeation tube on one side, and the remainder made up of the sample air being drawn in by the pump on the thermoelectron.

To obtain a 10ppm ammonia flow into the ammonia convertor, the temperature is varied around the tube. Using a 15cm ammonia permeation tube (analytical instrument development) a temperature of around 35°C is needed.

SIGNAL OUTPUT

0-10 MV
0-10 V

POWER REQUIREMENTS AT 115V

THERMOELECTRON 1250 W
 NH₃ CONVERTOR 250 W
 AIR HEATER 100 W

 TOTAL 1600 W

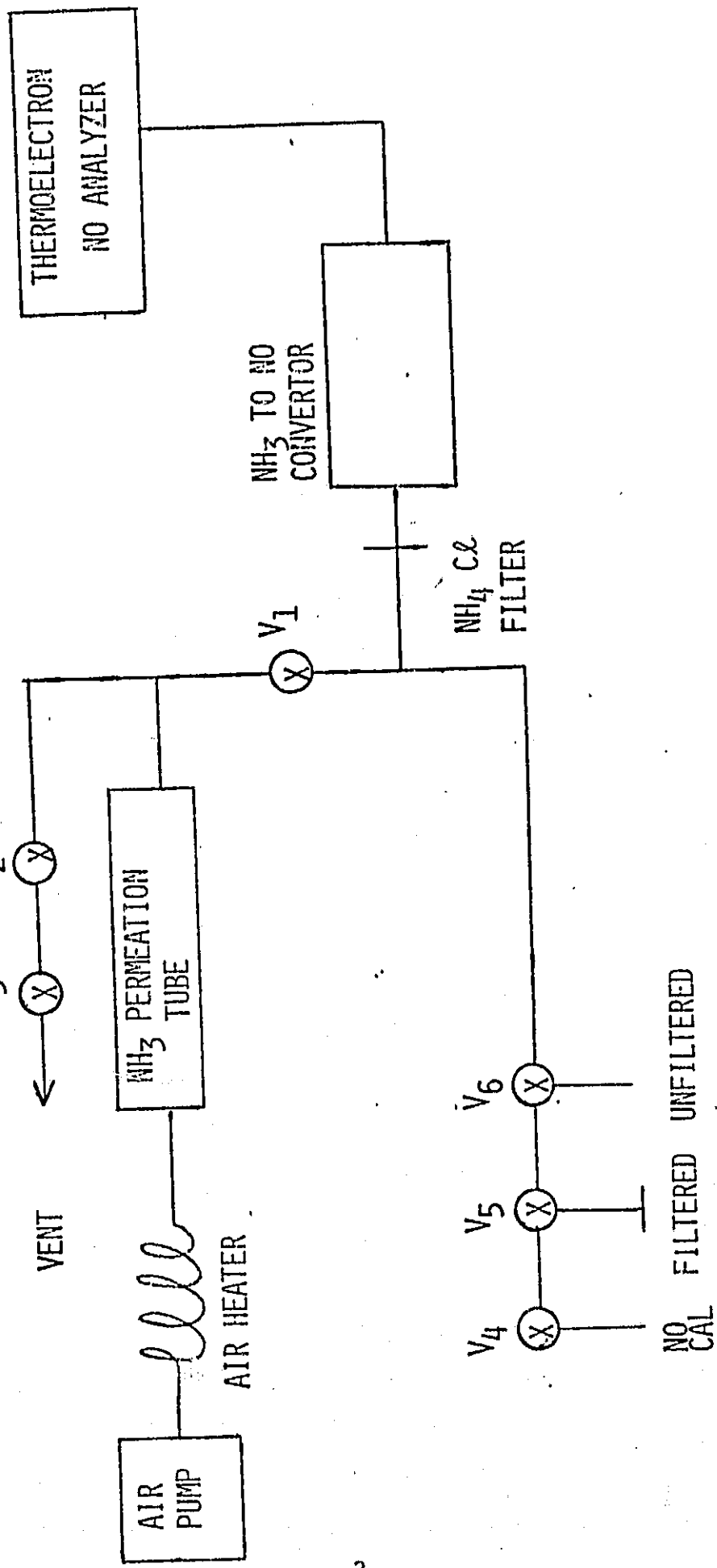

Figure 1

Figure 2 shows a record of the permeation rate of an ammonia tube. The tube was maintained at $33.0^{\circ}\text{C} \pm 0.05^{\circ}\text{C}$. This shows that these devices give a very regular permeation rate when the temperature is carefully controlled.

The temperature on the permeation tube is carefully controlled by preheating the air before it passed over the tube and using a high quality proportional control temperature controller to regulate the temperature. The permeation rate of the tube will change about ten percent for every 1°C temperature change so it is important that it be well thermostated. The small air pump, P_1 , is used to provide a positive air flow over the permeation tube. Valve, V_1 , regulates the total amount of air flow from the ammonia permeation tube entering the reaction chamber. This flow is kept at about 10 ml. per minute.

The ammonia flow can also be split by valves, V_2 and V_3 , to give a total ammonia flow of 1ppm. Valve, V_2 , is a regulating valve set initially to split the flow in a 1 to 10 ratio. V_3 is then used as an on/off control for the 0-1ppm range.

The inlet valves, V_4 through V_6 , are set up for different functions. Valve, V_4 , is used for calibration of the NO detector. In the calibration process, pump, P_1 , should be shut off so that the ammonia flow does not add to the total NO signal. Valve, V_5 , is set up to sample total acid content of the air. On the other valve, V_6 , a filter has been employed to differentiate between acid gas and acid aerosol. In studies on sulfuric acid aerosol and hydrochloric acid aerosol quantitative rejection of the acids were observed. The filter material used is a Millipore

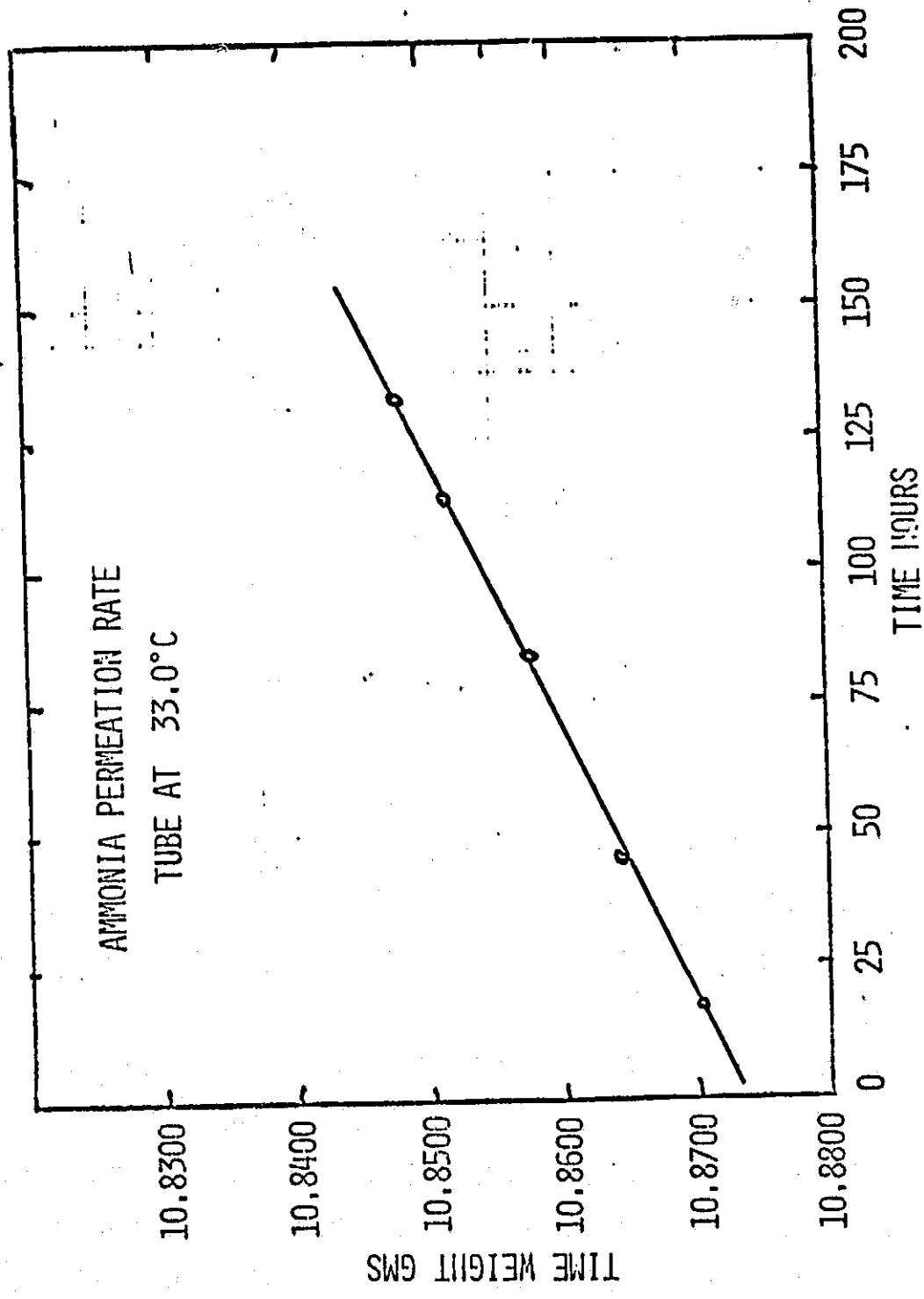

brand Fluoropore Filter. This is a teflon-like material which is not wet by aqueous solutions. A 1.0μ pore size was used. In studies on nominally dry HCl gas a loss of 20 percent of the sample was observed in the filter.

The plumbing downstream of the ammonia permeation tube is constructed of stainless steel tubing and valves. For the sample inlet stream an all glass system is used with teflon stopcocks. The entire valve arrangement is maintained at the same temperature as the ammonia permeation tube to avoid adsorption of HCl on the inlet system. No major effects of adsorption or bleeding were noticed.

For removal of the ammonium chloride before the convertor a millipore filter is employed. The ammonium chloride particles formed appear to be of quite large diameter and a 1.2μ filter was successful in removing them. At ambient temperature the residual vapor pressure of the ammonium chloride particles does not constitute a significant error.

Three different convertor styles were studied in order to determine the optimum conditions for the conversion of ammonia to nitric oxide. Commercially this conversion is run at 860°C on a platinum catalyst.² All of the convertors were evaluated for percentage conversion efficiency versus temperature. These curves are shown in Figure 3. All of them will reach 100 percent efficiency if the temperature is high enough. The best results were obtained with a stainless steel tube packed with a 80cm long roll of platinum gauze. Studies on a gold wool packed stainless steel tube and a platinum gauze packed Vycor tube

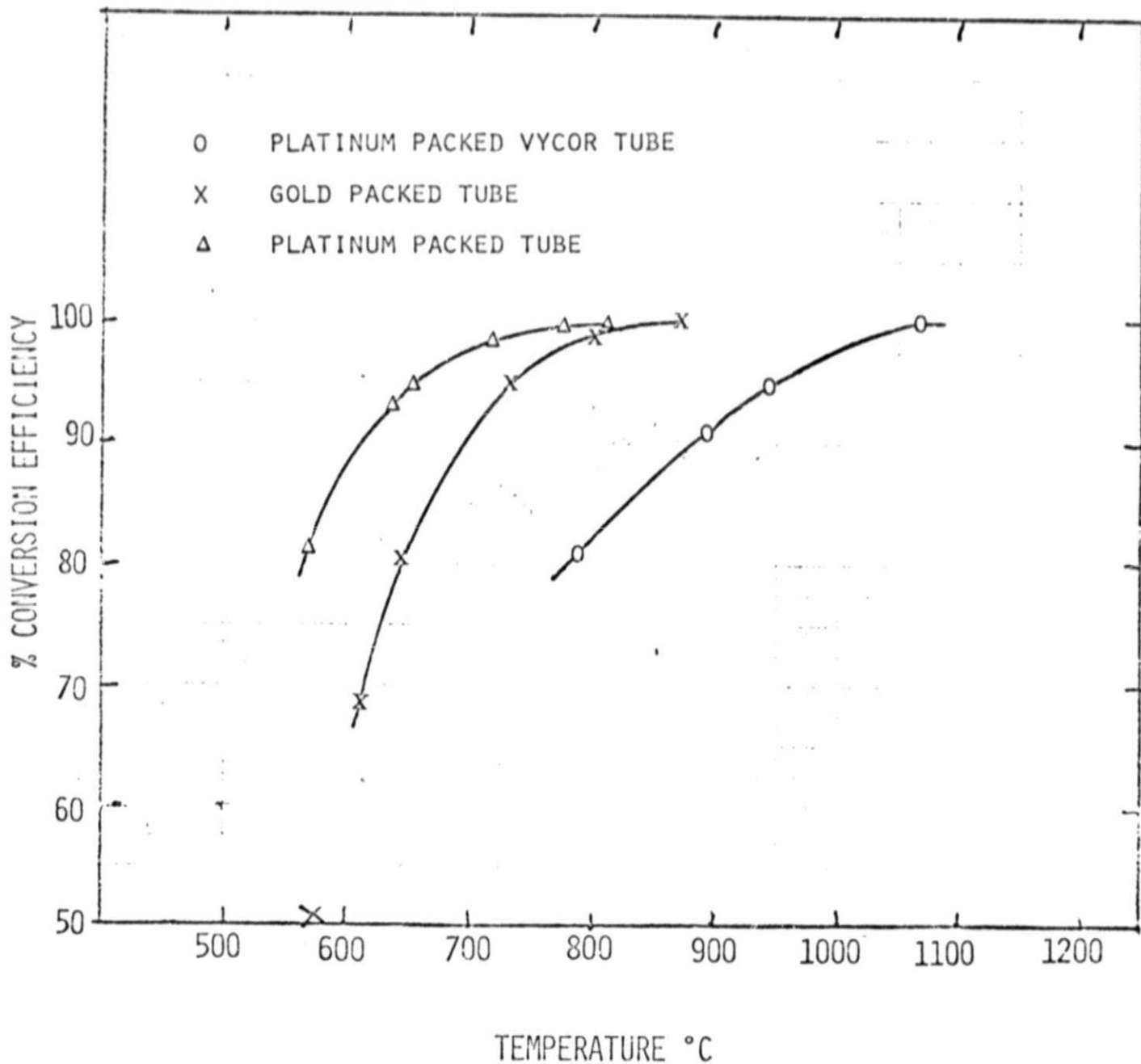

Figure 3

showed that these needed an additional 100-150°C to reach complete conversion. The conversion efficiencies were determined by comparing the weight loss from the ammonia permeation tube with the total NO signal observed. Type 321 stainless steel is the best material to use for the convertor. It is relatively resistant to scaling and cracking at high temperatures. With a convertor temperature of 900°C the total amount of air converted to NO is 0.15ppm.

On the 0-10ppm scale the response of the instrument is quite rapid and it will reach 90 percent of maximum signal in six seconds. It is very interesting to note that immediately before the signal decreases, indicating the presence of an acid there is a very sharp increase in the signal. This is shown in Figure 4. No explanation can be given for this behavior and it does not add uncertainty to the measurement. The limit of sensitivity for short term measurements is about 0.05ppm. This could certainly be increased if the measurement time were increased and a longer average was taken. The instrument gives a linear response over this total range 0-10ppm. This is shown in Figure 5.

The return of the baseline is somewhat slower depending on the amount of acid in the sample. If a moderate sample of approximately 2ppm is used the system will return to a base line in about 30 seconds.

A feasibility study was conducted on the use of the dehydrohalogenation reaction of ethylchlorine for purposes of calibration of the HCl inlet system.

RECORDER TRACE OF CALIBRATION STUDY

THERMOELECTRON 12A

CHART SPEED 20IPH

CONVERTOR TEMPERATURE 900°C

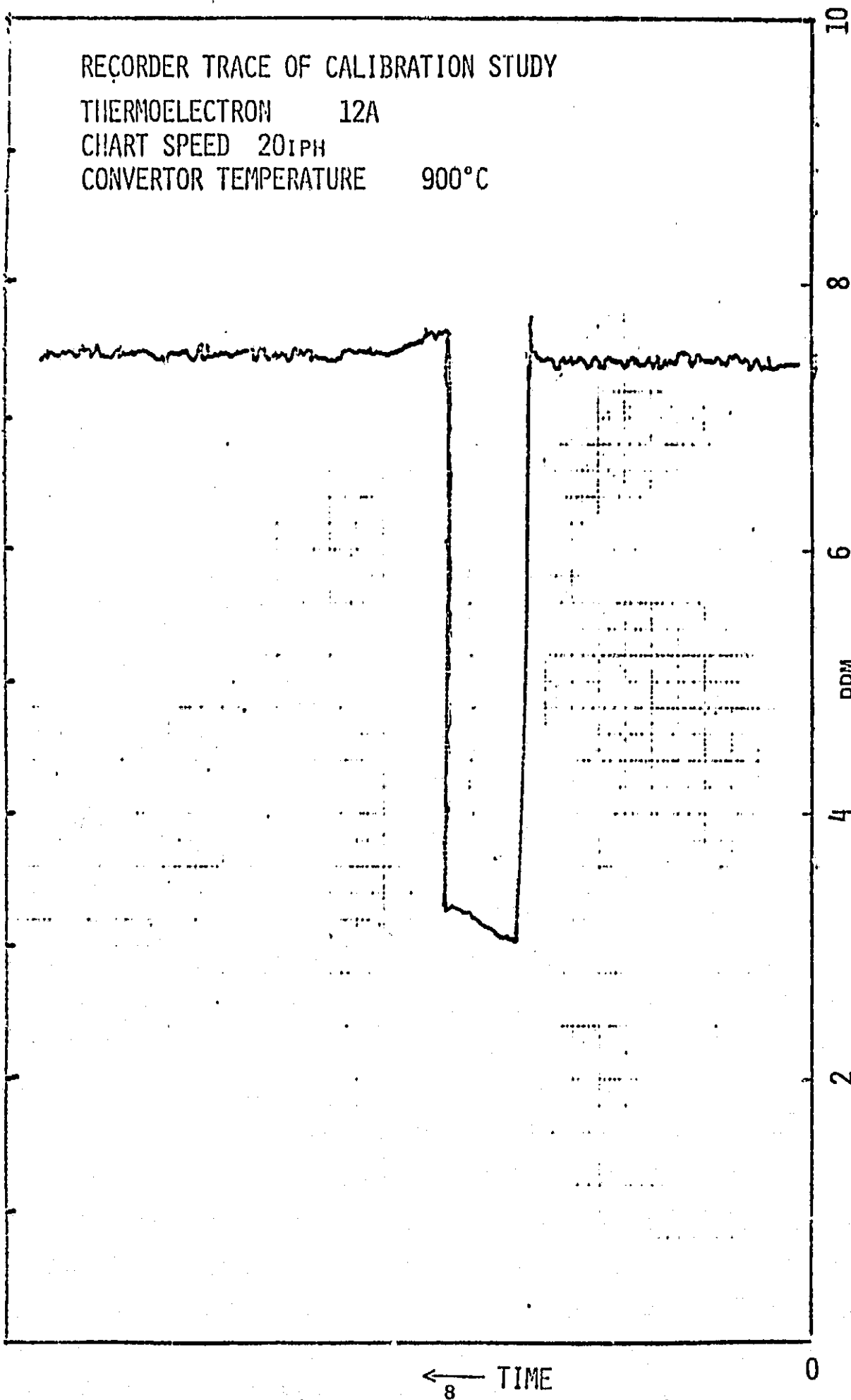

Figure 4

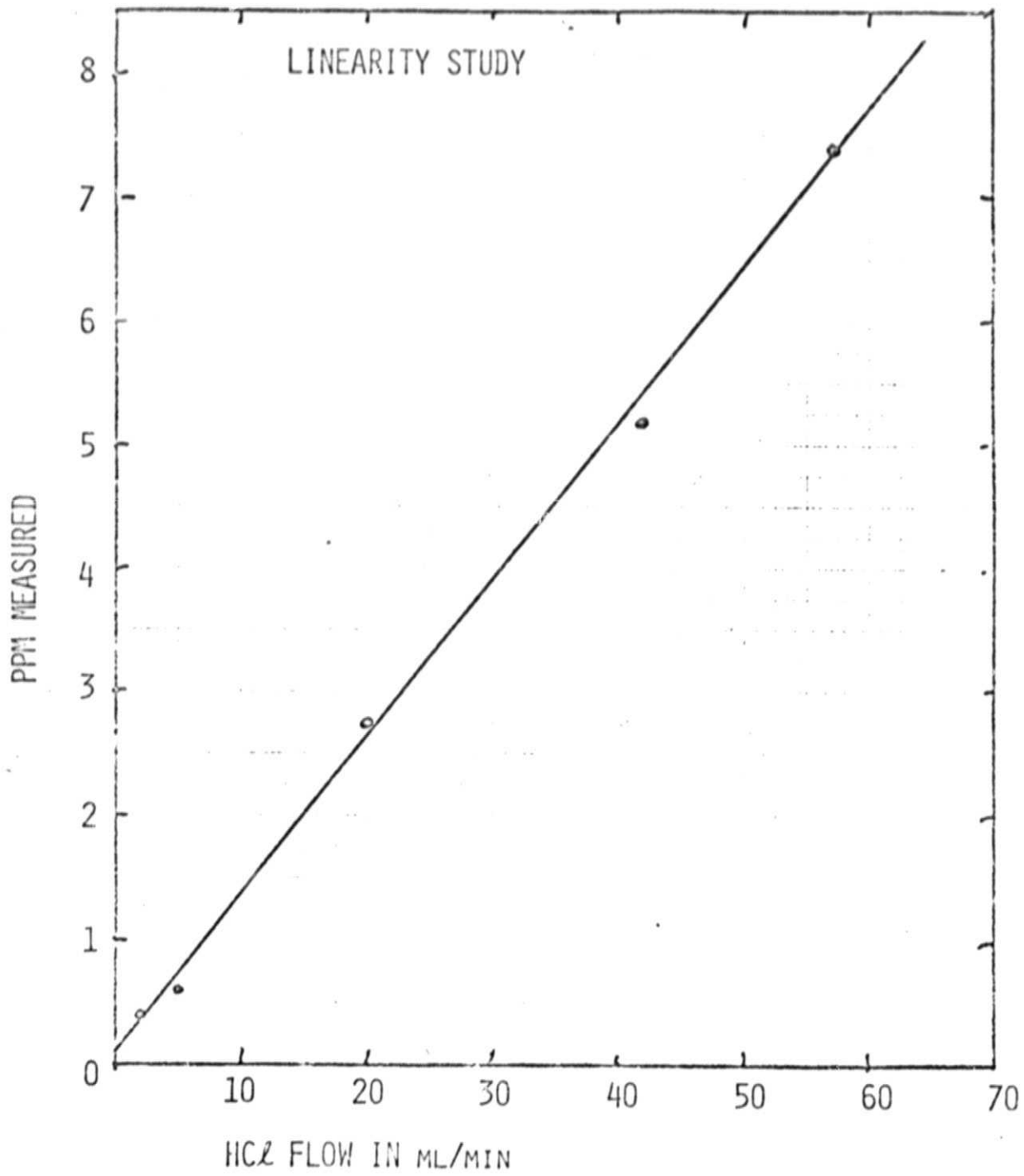
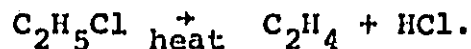

Figure 5

A diagram of the system is shown in Figure 6. The desired reaction is



A Vycor tube lined with barium sulfate was used as the convertor. It was necessary to heat the tube to 600°C before the reaction would go to completion. This high temperature could be reduced if i-propylchloride or t-butylchloride were used as the organic material.³ In several attempts we were unable to construct a suitable permeation tube for these materials.

Table I details the species which the system responds to. A + indicates a positive interference, A - indicates negative interference and O indicates no interference.

Table I

Species	Interference
NH ₃	+
NO ₂	+
NO	+
acids (gas or aerosol)	-
SO ₂	O
CO	O
CO ₂	O
H ₂ O	O
Al ₂ O ₃ particulate	O
N ₂	O
O ₂	O

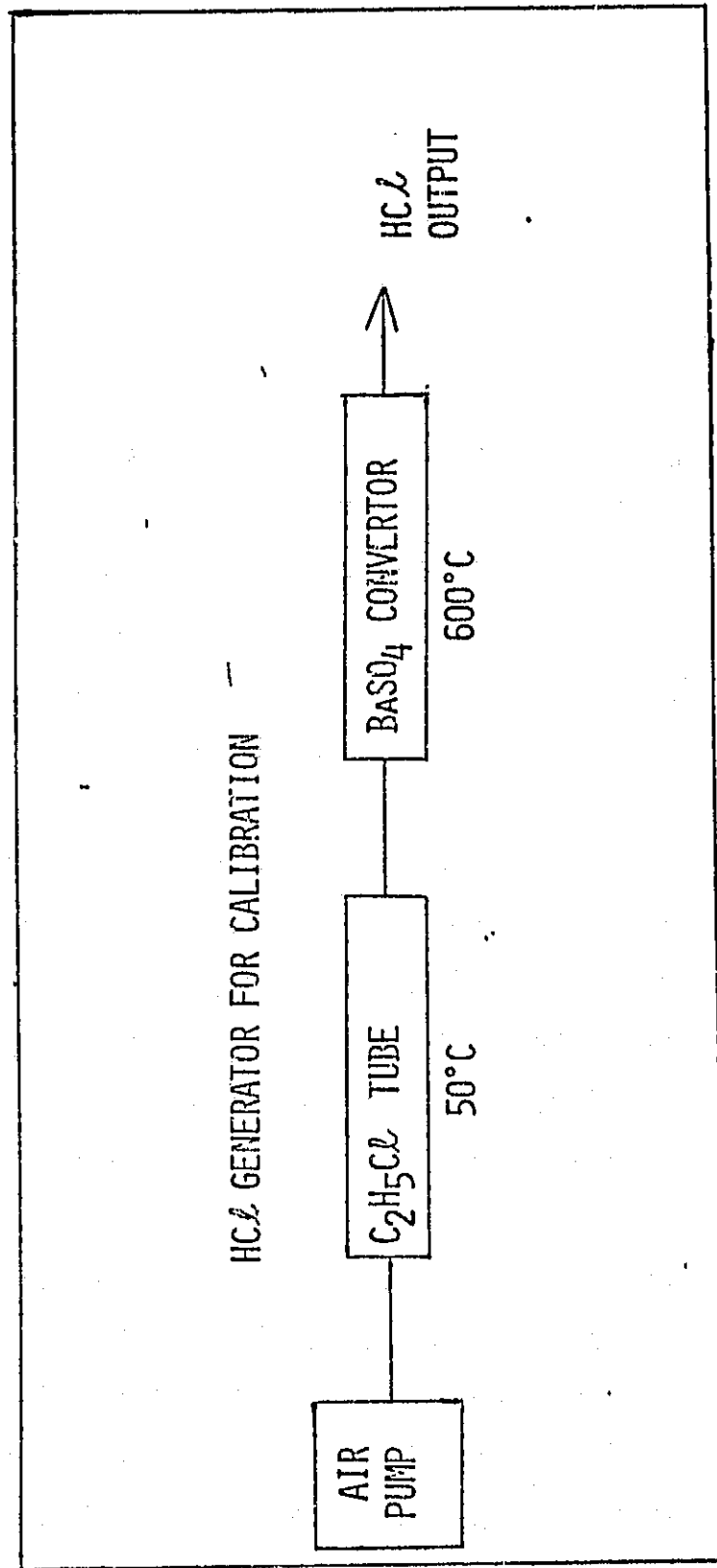

Figure 6

REFERENCES

1. Dzubay, J. G., H. L. Rook, and R. K. Stevens, Environmental Protection Agency, Research Triangle, North Carolina.
2. Bond, A., "Catalysis by Metals", Academic Press, New York, 456, 1962.
3. Paulino, A., F. J. Lopez, O. Blasini, M. Paez, N. Heinrich, An. Quim, 65, 899, 1969.

PART II

REPORT OF TRIP TO NASA KENNEDY SPACE CENTER,

February 9-11, 1974,

TO USE EQUIPMENT DEVELOPED UNDER GRANT NGR 23-005-599.

Measurement Team Report

The chemiluminescent HCl instrumentation arrived in good condition and was assembled and tested on February 9 and 10. The calibration remained quite constant during shipping and only a minor adjustment was needed.

On the evening of the 10th the wind direction mandated that monitoring operations be carried out from sea. The instrument was loaded on an Air Force LCU and set up on the fore deck. Once the instrumentation was loaded aboard very little work was needed as the instrumentation can be transported in two packages, the main instrumentation case and a small oxygen cylinder. Upon leaving the dock strong signal from the NO_x produced by the ship board generator were observed. This is shown in Figure 1. The Wilks monitoring instrumentation on the boat observed CO_2 signals, but the Andros CO unit was not observing any CO, although its inlet was in the exhaust. The chemiluminescent HCl instrument ran throughout the night with no problems.

At approximately 7:00 AM an attempt was made to change the power source to the starboard generator. It was not working properly and put out approximately 50 volts. This caused a blown fuse on the permeation tube heater. This was not noticed until an hour later. The calibration of the instrument was not affected but there was some baseline drift as the permeation tube warmed up.

The launch took place at 9:48 AM. The ground cloud and exhaust cloud appeared to be a very pure white. The ground cloud

was elongated downwind at about $T + 10$ sec. It merged into the background at about $T + 10$ minutes. At $T + 45$ minutes a high altitude portion of the cloud was still visible.

Figure 2 shows the recorder trace from $T + 15$ on. The declining baseline is due to the recent startup of the ammonia permeation tube. The HCl concentration at predicted cloud passage time was less than 0.05 ppm.

The equipment functioned quite well during the entire time. The calibration of the NO detector held during operation. The instrumentation was portable although it is rather heavy (170 lbs.). A convenience is that the package needs no field assembly and can be carried intact. The only accessory needed is a small oxygen tank. Field calibration was done using a small tank of NO calibration gas. A zero gas trap was not supplied. This was improvised by using air from a plastic beach ball.

This trip suggested several improvements which could be made on our equipment. Both lower weight and lower power requirement would be an advantage. The flow stability of the inlet system could be improved to avoid shifts in the baseline due to wind changes. The 10 ppm option could be deleted and would simplify the plumbing. The calibration worked very well using a tank of NO calibration gas. The ammonia permeation tube also served as a calibration. A field calibration source of HCl would be valuable.

The entire instrument (NO detector on loan from Thermo-Electron Corporation, Waltham, Mass. 02154, via Dr. W. J. Zolner) and inlet system constructed on grant NGR 23-005-599 was turned over to NASA Langley for their evaluation. The instrument was discussed

with Mr. Burt Emerson. Two copies of an instruction manual have been forwarded to Mr. W. E. Lanford.

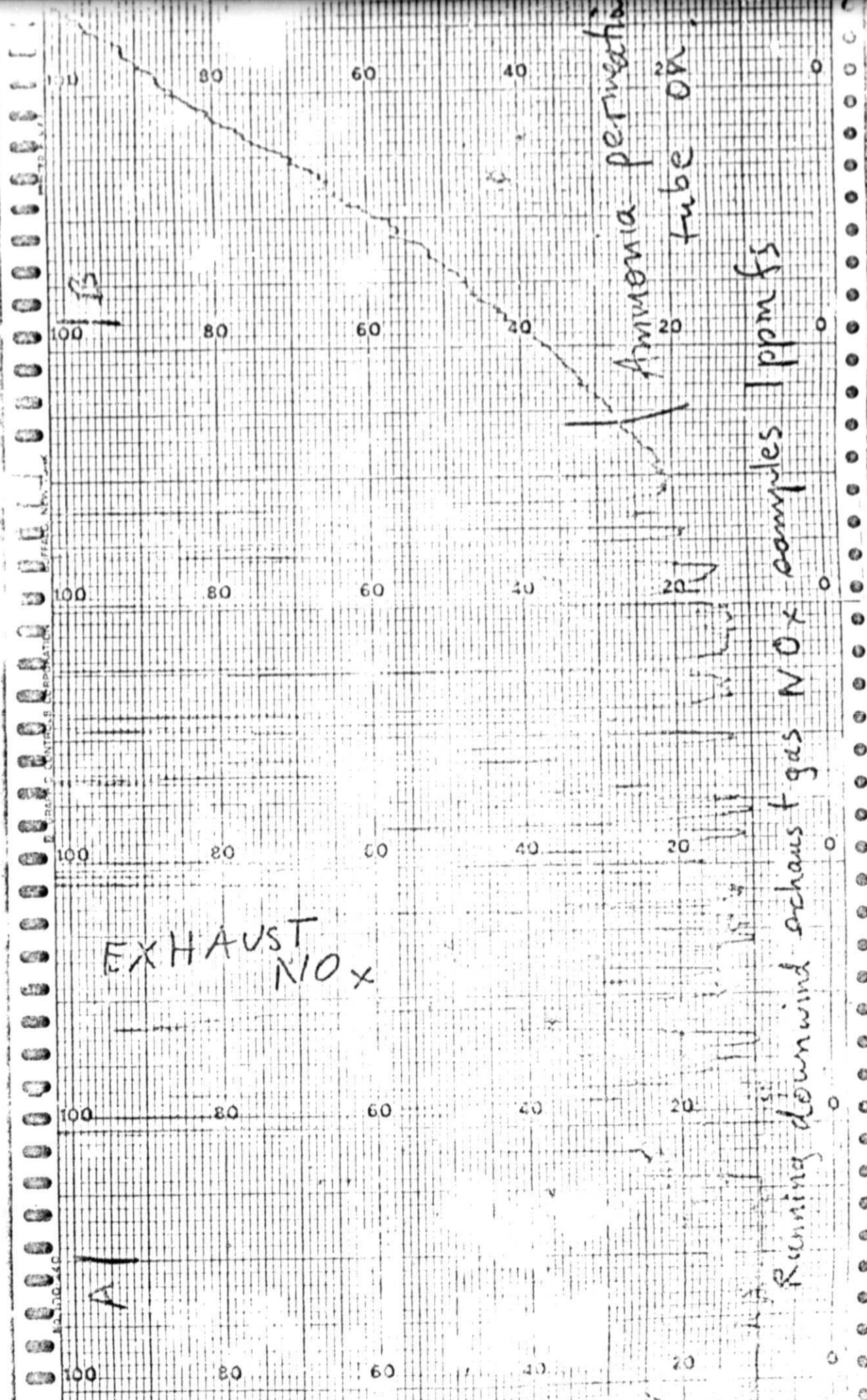

REPRODUCIBILITY OF THE ORIGINAL PAGE IS POOR.

Course 1

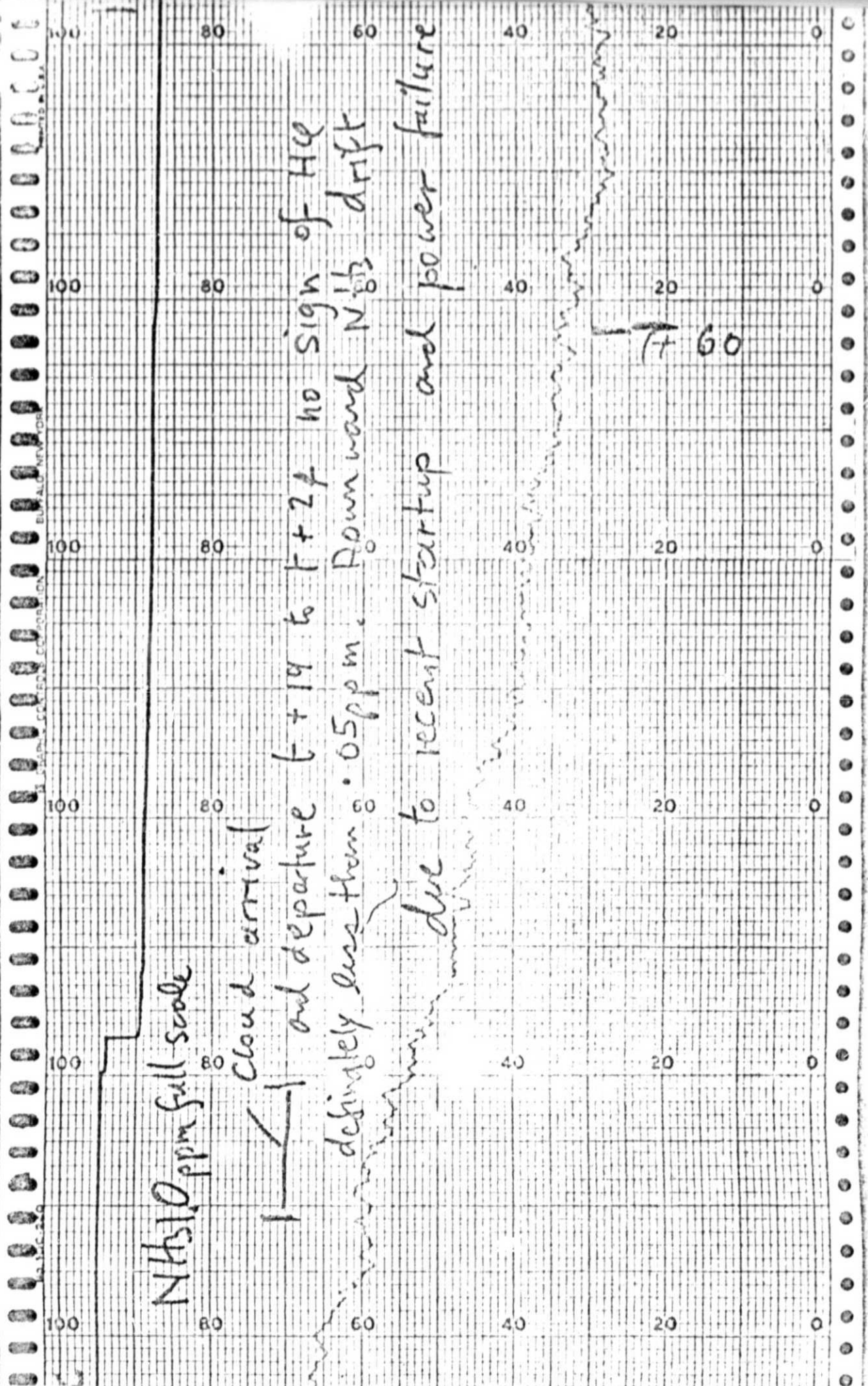

NH₃ ppm full scale

Cloud arrival

and departure t+14 to t+24 no sign of H₂ definitely less than 0.05 ppm. Downward NH₃ drift

due to recent startup and power failure

t+60

APPENDIX I

OPERATING INSTRUCTIONS

MARK I, CHEMILUMINESCENT, HCl DETECTOR

D. H. Stedman

and

G. L. Kok

University of Michigan
Ann Arbor, Michigan 48104

(313-764-7334)

PRINCIPLE

The HCl detector is based on the reaction between NH_3 and HCl. The resulting decrease in NH_3 is read on a chart recorder and is directly proportional to the HCl concentration.

Figure 1 is a block diagram of the instrument.

Front panel controls are: Coarse and fine grain, and zero potentiometers for the HV supply and electrometer respectively, NH_3 converter temperature regulator and switch. PMT switch, permeation tube heater switch, ozonizer switch and main power switch. The permeation tube temperature is regulated by a screw potentiometer in the inside top, together with the fuses for appropriate sections of the equipment.

OPERATION

Check dark current on x100 scale, suppress with zero control if desired. Turn on converter to 1500°F and ozone switches and allow twenty minutes for stabilization. Turn converter to 1600°F and check for increase in signal (recheck dark current by turning off ozone). If no increase reset to 1500°F. The signal level is now 2 ppm above the dark current and HCl introduction will cause a linear decrease in this signal. If the instrument is to be used daily leave main power and PMT switches on.

COMPONENTS

The filters are all 0.2 μ pore size millipore filters, spare filters are provided. Two capillaries are thermo-

meter tubing. The main sampling inlet is a heated interchangeable high-chrome stainless steel syringe needle. The heater can be slid off the needle which still connects to the power supply.

The temperature controlled NH_3 permeation tube housing is in the upper half of the detector in a foam rubber enclosure. It is a 200 cm copper preheat coil joined to the stainless steel tube chamber. Disassembly is via the $\frac{1}{8}$ " swagelok just to the rear of the inlet needle. A flow of 10 ml min^{-1} is used to sweep the NH_3 into the teflon and stainless steel mixing region. In this mixing region the $\text{HCl} + \text{NH}_3$ reaction takes place, depositing the NH_4Cl on the filter. Unreacted ammonia goes through to the converter. A choice of needles is available which determines the full scale NH_3 signal. Wider latitude can be obtained by changing the permeation tube temperature (do not exceed 40°C), the signal goes up about 10% per $^\circ\text{C}$. The inlet system is also equipped with an extension which enables one to sample remotely, with some penalty in response time.

The NH_3 conversion furnace carries out the reaction $\text{NH}_3 + 2.5\text{O}_2 \rightarrow \text{NO} + 1.5 \text{H}_2\text{O}$. The mechanism is uncertain but it appears that the stainless steel with platinum catalyst does drive this reaction to completion at temperatures above 800°C . The setting at 1500°F is a minimum one, the converter may lose capacity and a higher temperature will then be required. This can readily be determined by increasing the temperature setting to 1600°F . If there is no change in signal then 1500°F was sufficient.

After the furnace the equipment is a conventional chemiluminescent NO detector. These devices are not without their peculiarities. The PMT housing is an RCA packaged HV supply and electrometer controlled by the front panel and giving a 0-10 v output. The dark current is unfortunately not negligible, and is a function of tube temperature. Thus shifts in baseline have to be monitored.

The chemiluminescent reaction $\text{NO} + \text{O}_3 \rightarrow \text{NO}_2^* + \text{O}_2$ requires a source of ozone. The ozonizer supplied in the detector is a 7.5 kv silent discharge type running on ambient air. Its output is effected by humidity, a drying tube is included under the lid to stabilize the ozone supply. An increase in stability and sensitivity can be obtained by using cylinder oxygen at 2-5 psi for the ozonizer. The ozonizer flow is set at 40 ml min^{-1} . Ozone will disastously deteriorate vacuum pump oil so it has to be removed by the "ozone killer". This device is thermostatically controlled at 375°C , hot enough to decompose the ozone.

MALFUNCTION

In principal anything on which so much care has been lavished should not malfunction. In practice a number of problems may arise.

- a) Wandering sensitivity may be caused by spent drier on the ozonizer (replace drier or use O_2 tank). It may be caused by insufficient converter temperature. Try 1600°F .

- b) No signal check ozonizer flow and HV (7.5 kv 60 Hz). Permeation tubes may be empty due to overheating and bursting or a leak. Otherwise a life of 6 months or more is expected.

CALIBRATION

There are three independent calibration methods.

- a) NH₃. So long as the permeation tube is thermostated and not empty it is a primary gravimetric standard and should be stable at 1 ppm signal over dark current when the converter is on and fully functional. The weight loss can be checked once per week.
- b) NO. A standard tank of not more than 50 ppm NO can be used to check calibration on the xl scale. The instrument is linear on all scales. Standard tanks of NH₃ or NO₂ can be used when the converter is on.
- c) HCl. Any source of calibrated HCl standard (dilution, permeation) can be used directly to measure the HCl response.

DRIFT

The nature of the ozone/air source causes some instrumental calibration drift down (about 10% in 30 min) after first turning on. After that the signal is stable.

The dark current drifts as a function of the PM tube temperature and has to be checked periodically by turning off the ozonizer.

CONVERSION TO NO/NO_x DETECTION

The detector is already a detector of NO and NO_x as built, for dedicated work some conversion is advantageous.

The instrument can be converted to a fast NO detector by deleting all the inlet system NH₃ permeation tube holder, converter furnace and filters and running the needle inlet directly to the reactor sample inlet. For NO_x detection delete only the NH₃ source, not the converter furnace. 1500°F is adequate for complete NO_x conversion.

AUTOMATION AND FURTHER IMPROVEMENT

If a chemiluminescent HCl detector were to be used in the future some improvements can be made. Cooled thermostatic control on the PMT housing will be useful for controlling dark current drift. A bypass solenoid from the NH₃ inlet past the converter would provide a faster dark current check and signal calibration.

Solenoid actuation of a number of valves, and a built in zero air trap would be required.

FIGURE 1

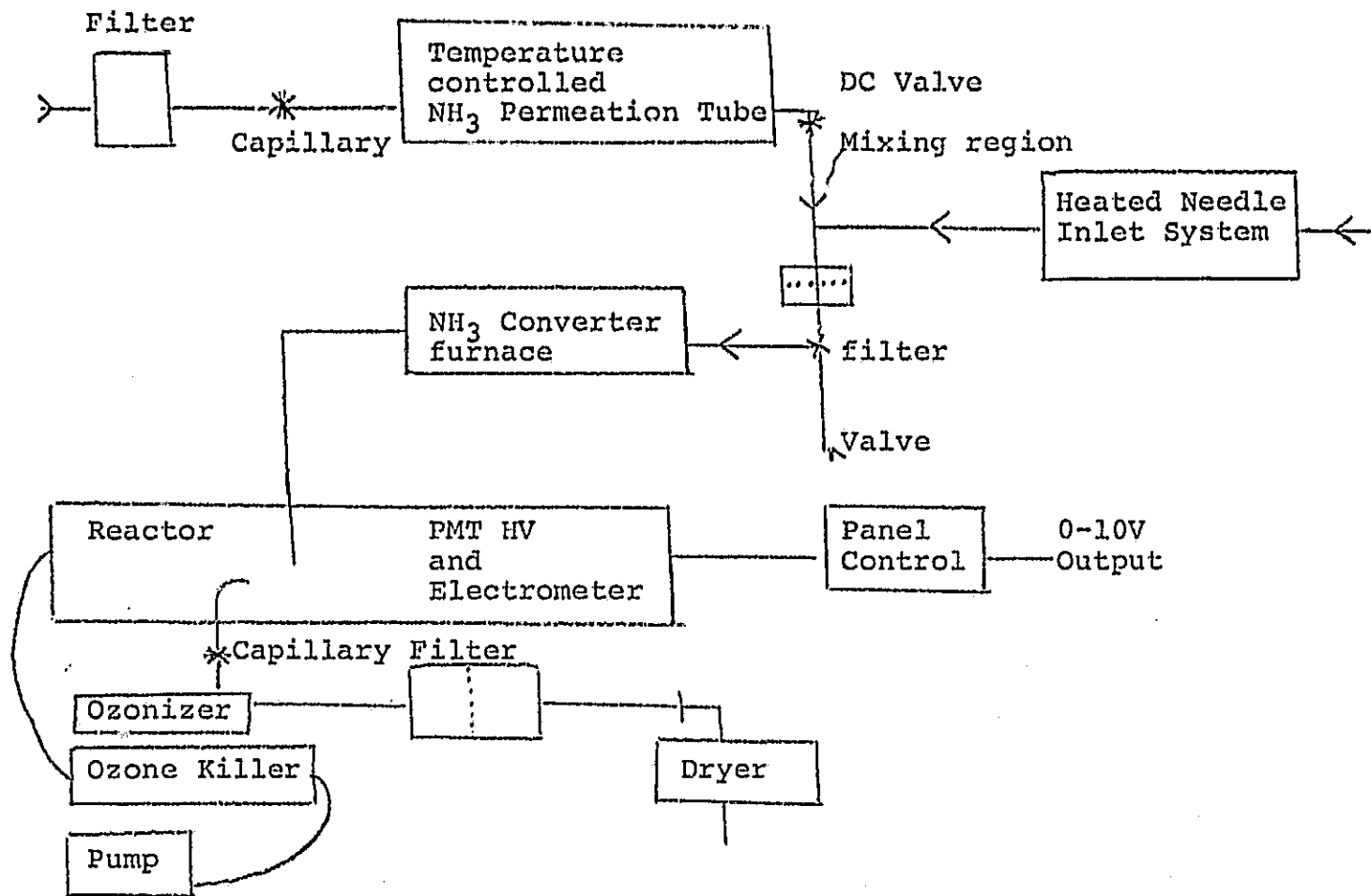

Operating parameters

Inlet system	40-60°C
Permeation tube	34°C
Converter furnace	815°C (1500°F)
Ozone killer	375°C
Pressure	3 mm Hg

SUPPLIERS

NH₃ permeation tubes, ea. \$18, multiples \$14

Analytical Instrument Development
250 Franklin Street
West Chester, Pennsylvania

Furnace insulation

Johns-Mansville Super X 2000

Platinum gauze, \$16.50 ea.

Arthur H. Thomas Co.

Temperature controller and thermistor
controller 11CT3-3, \$41
thermistor 25324-1, \$24

Texas Instruments
34 Forest Street
Attleboro, Massachusetts 02703

Filters

NH₄Cl RAWP 02500, \$12/100

Millipore Corp.
Bedford, Massachusetts 01730

Filter holder, \$27/pack of 6, #1109

Gelman Instrument Co.
600 S. Wagner Road
Ann Arbor, Michigan 48106

Photomultiplier Tube, \$650, RCA PF 1023A

RCA Electronic Products
Lancaster, Pennsylvania

Vacuum Pump, Cenco Hyvac 2, \$200

Central Scientific Co.
2600 S. Kostner Avenue
Chicago, Illinois 60623

Ozone Killer , heat #C208, thermostat #1A1C2, \$25

Vulcan Electric
Kezar Falls, Maine 04047

Msc.

7500 Volt neon sign transformer for ozonizer
Resistors and switches for PMT electronics

Heat control

LFE #232-2022-2100, \$125

LFE Corp.
1601 Trapelo Road
Waltham, Mass. 02154

APPENDIX II

CHEMILUMINESCENT ANALYSIS OF GASEOUS AND AEROSOL HYDROGEN CHLORIDE

G. L. Kok and D. H. Stedman
Chemistry Department
University of Michigan
Ann Arbor, Michigan 48104

Submitted to "Analytical Chemistry"

ABSTRACT

A gas phase acid selective inlet system has been constructed for a chemiluminescent nitric oxide (NO) analyzer. The sample stream is mixed with a 9ppm flow of ammonia, the resulting ammonium salt is filtered off and the remaining ammonia catalytically converted to nitric oxide. The acid concentration is measured as the net decrease in the NO concentration. The only interferences are nitrogen containing compounds. The limit of sensitivity of the method is about 0.05 ppm.

Introduction

Hydrochloric acid gas is an atmospheric pollutant from a number of industrial sources¹ and from the effluent of solid fuel rocket boosters². Immediately after the launch of solid fuel rocket boosters concentrations of hydrogen chloride of up to 10 ppm have been predicted².

There are very few continuous methods of the analysis of hydrogen chloride under these conditions. These are wet chemical devices using coulometric operation³, chloride specific ion electrode systems⁴, and a liquid phase chemiluminescence technique⁵. Dzubay et. al.⁶ have reported a preliminary study of a gas phase system along the same approach as reported here.

Instrumentation

We have developed an inlet system for a commercially available chemiluminescent nitric oxide (NO) detector to enable the measurement of total (gas and aerosol) atmospheric acid, or gaseous atmospheric acid only. The instrument used in this study was a Thermoelectron Model 12A (Thermoelectron Instruments Waltham, Mass.) It has a full scale sensitivity of 0.01 ppm on its most sensitive scale. The NO detector is self contained in a compact package and the acid selective inlet system mounts directly on top of the case. The system has capabilities of measuring acids in the 0-10 ppm and 0-1 ppm range.

The principal of operation is the reaction of hydrogen chloride aerosol or gas with ammonia, and the conversion of the remaining ammonia to nitric oxide. The nitric oxide is analyzed using a chemiluminescent detector.⁶ The net acid concentration is measured as a decrease in the ammonia signal.

The system operates on the following set of reactions.



This reaction takes place homogenously or heterogenously in the inlet system. The residual ammonia is converted to NO in a high temperature catalytic converter.

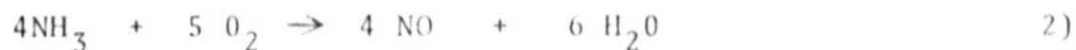

The system can easily be adapted to any conventional chemiluminescent NO analyzer.

Details of the system are shown in Figure 1. The sample flow into the NO analyzer is split into two streams, a small air flow (10 ml min^{-1}) over the ammonia permeation tube on one side, and the remainder made up of the sample air being drawn in by the sampling pump of the NO analyzer (1000 ml min^{-1}). To obtain a 10 ppm ammonia flow into the ammonia converter, the temperature is varied around the ammonia permeation tube. Using a permeation tube 15 cm in length a temperature of about 35°C is required. A detailed description of the parts used can be obtained from the authors.

The temperature on the permeation tube is carefully controlled by preheating the air before it is passed over the tube and using a proportional control temperature controller to regulate the temperature. The permeation rate of the tube will change about ten percent for every 1°C temperature change so it is important that it be well thermostated. A small air pump is used to provide a positive air flow over the permeation tube. Valve, V₁, regulates the total amount of air flow from the ammonia permeation tube entering the reaction chamber. This flow is kept at about 10 ml. per minute. The ammonia flow can also be split by valves, V₂ and V₃, to give a total ammonia flow of equivalent to 1 ppm. Valve, V₂, is a regulating valve set initially to split the flow in a 1 to 10 ratio. V₃ is then used as an on/off control for the 0-1ppm range.

The inlet valves, V₄ through V₆, are set up for different functions. Valve, V₄, is used for calibration of the NO detector. Valve, V₅, is set up to sample total acid content of the air. The other valve, V₆, employs a filter to differentiate between acid gas and acid aerosol. The filter material used is a Millipore brand Fluoropore Filter. This is a teflon-like material which is not wet by aqueous solutions. A 1.0u pore size was used.

The plumbing downstream of the ammonia permeation tube is constructed of stainless steel tubing and valves. For the sample inlet stream an all glass system is used with teflon stopcocks.

The entire valve arrangement is maintained at the same temperature as the ammonia permeation tube to avoid adsorption of HCl on the inlet system. No effects of adsorption or bleeding were noticed except in respect to the response time.

For removal of the ammonium chloride before the converter a millipore filter is employed. The ammonium chloride particles formed appear to be of quite large diameter and a 1.2u filter was successful in removing them. At ambient temperature the residual vapor pressure of the ammonium chloride particles is less than 0.01 ppm NO equivalent.

For conversion of the residual ammonia to NO a stainless steel tube packed with platinum gauze is used. Commercially the conversion of ammonia to NO is done at 860°C ⁷. In studies on the platinum converter it was determined that total conversion efficiency was reached at a temperature of 900°C . This was confirmed by comparing the total weight loss of the permeation tube with the amount of NO measured. Type 321 stainless steel proved most durable for construction of the converter.

Results and Discussion

On the 0-10 ppm scale the instrument reaches 90 percent of maximum signal in 15 seconds. The limit of sensitivity for short term measurements is about 0.05 ppm. The instrument was shown to give a linear response over the total range 0.2 - 9 ppm.

In studies on the differentiation of acid gas and acid aerosol, total rejection of sulfuric and hydrochloric acid mist by the filter was observed. A 20 percent rejection of nominally dry hydrogen chloride gas was observed.

The system measures total atmospheric acid and is not specific for any particular acid. Any nitrogen containing compounds will act as a negative interference as these compounds are converted to NO by the ammonia converter, No interferences are noted from H₂O, SO₂, CO, CO₂ and other commonly atmospheric gases.

The limitations of the method are those commonly encountered with NO analysis⁷. The modifications described in this article permit multiple use of a NO analyzer, permitting measurement NO, NO_x, NH₃ or acids.

Acknowledgment

The authors wish to thank Thermoelectron Corporation for the loan of the model 12A and acknowledge support from NASA Langky under grant NGR 23-005-599.

1. Q.R. Stahl, Air Pollution Aspects of Hydrochloric Acid, PB 188 067, National Technical Information Service, Springfield, Virginia, 1969
2. Environmental Statement for the Space Shuttle, NASA, Washington, D. C. 20546 (1972)
3. D. F. Miller, W. E. Wilson, Jr., and R. G. King, J., Air Poll. Control. Assoc. 21 414 (1971)
4. Orion Research, "Analytical Methods Guide" 11 Blackstone St., Cambridge, Mass., 02139
5. Geomet Inc., 2814a Metropolitan Pl., Pomona, California 91767
6. J. G. Dzubay, H. L. Rook, and R. K. Stevens, Environmental Protection Agency, Research Triangle, North Carolina
7. D. H. Stedman, E. F. Daby, F. Stuhl, and H. Niki, J. Air Poll. Control. Assn. 44, 113 (1972)
8. A Bond, Catalysis by Metals, Academic Press, New York, (1962)

Figure 1 Block diagram of chemiluminescent acid analyzer

Figure 2 Recorder trace showing 0-1 and 0-10 ppm scales

