

Pmix

F78

Skylab

EARTH RESOURCES EXPERIMENT PACKAGE

CRITICAL DESIGN REVIEW



DRA

8-11 DECEMBER

(NASA-CR-138380)	SKYLAB EARTH RESOURCE	N74-22961
EXPERIMENT PACKAGE	CRITICAL DESIGN REVIEW	
(Martin Marietta Corp.)	136 p HC \$10.00	
<i>116</i>	CSSL 14B	Unclas
		63/13 16148

MARTIN MARIETTA
DENVER DIVISION

EREP - MDA

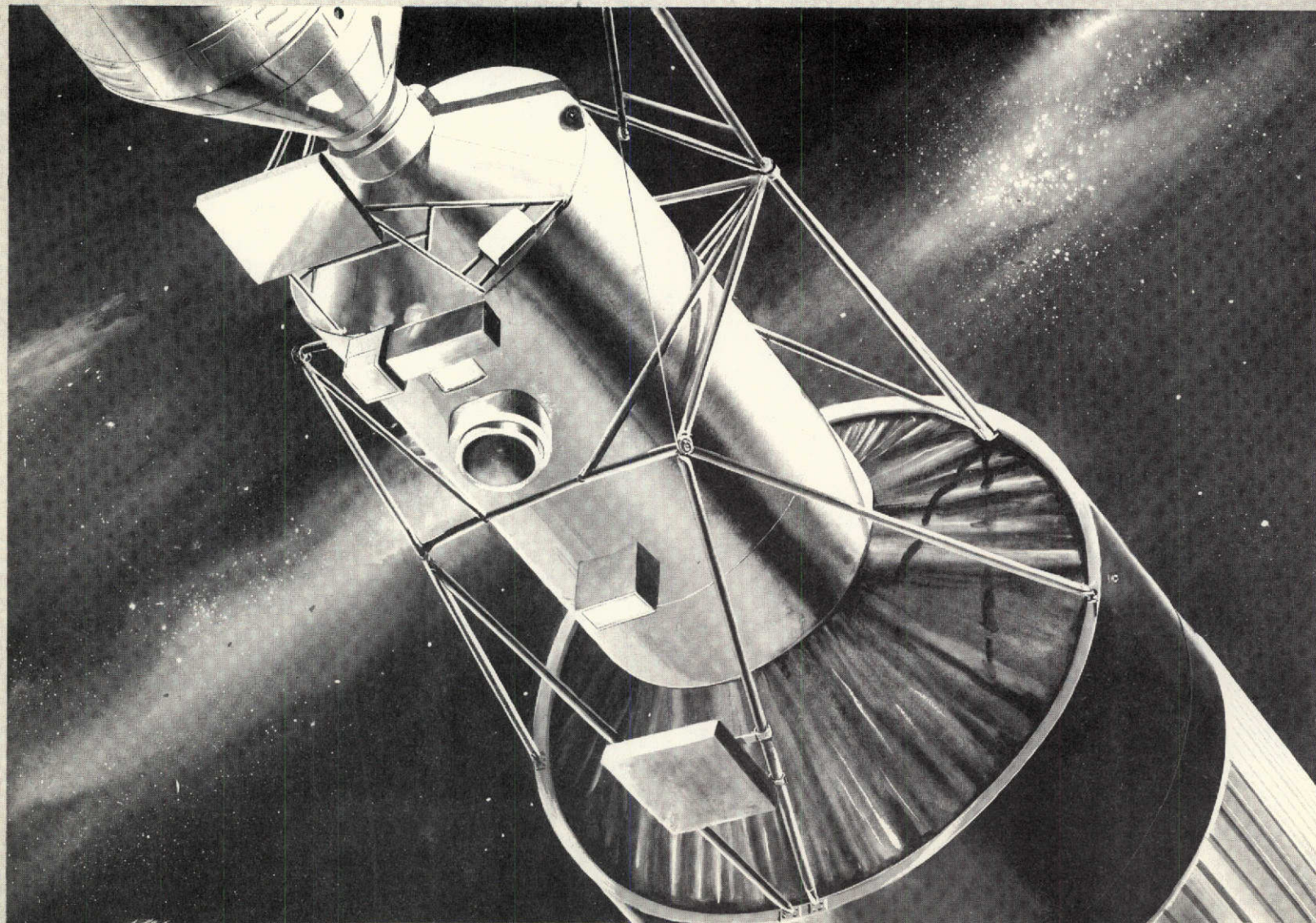

EREP CDR AGENDA



R. A. W.

Meeting	NASA Chairman/ MMC Responsibility	Location	Time
TUESDAY, DECEMBER 8			
● General Meeting		Presentation Rm 6th Floor, SSB	11:00 AM
● Electronics Review Team	C. Jackson W. Bollendonk	Room 404, SSB	3:00 PM
● Electronics ^{Electrical} Review Team	P. Miglicco D. McCubbin	Room 500-K, SSB	3:00 PM
● Structural/Mechanical/Op- tical Review Team	L. Bernardi W. Hooker	Presentation Rm 6th Floor, SSB	3:00 PM
● Thermal Review Team	R. Frost D. Sousek	Room 605, SSB	3:00 PM
● Reliability/Quality Assur- ance/Safety Review Team	G. House J. McDermott	Room 505, SSB	3:00 PM
● Test and Manufacturing Review Team	M. Coody R. Gregory	Room 600-B, SSB	3:00 PM
WEDNESDAY, DECEMBER 9			
● Review Teams	Same	Same	8:30 AM
● Crew Station Review	D. Jacobs R. Smith	Room 310, SSB	8:30 AM
THURSDAY, DECEMBER 10			
● Pre-Board	R. Frost G. Stucker	Presentation Rm 6th Floor, SSB	8:30 AM
FRIDAY, DECEMBER 11			
● Board	R. Machell E. Wood	Presentation Rm 6th Floor, SSB	8:30 AM

MARTIN MARIETTA EREP ORGANIZATION

MARTIN MARIETTA
DENVER DIVISION

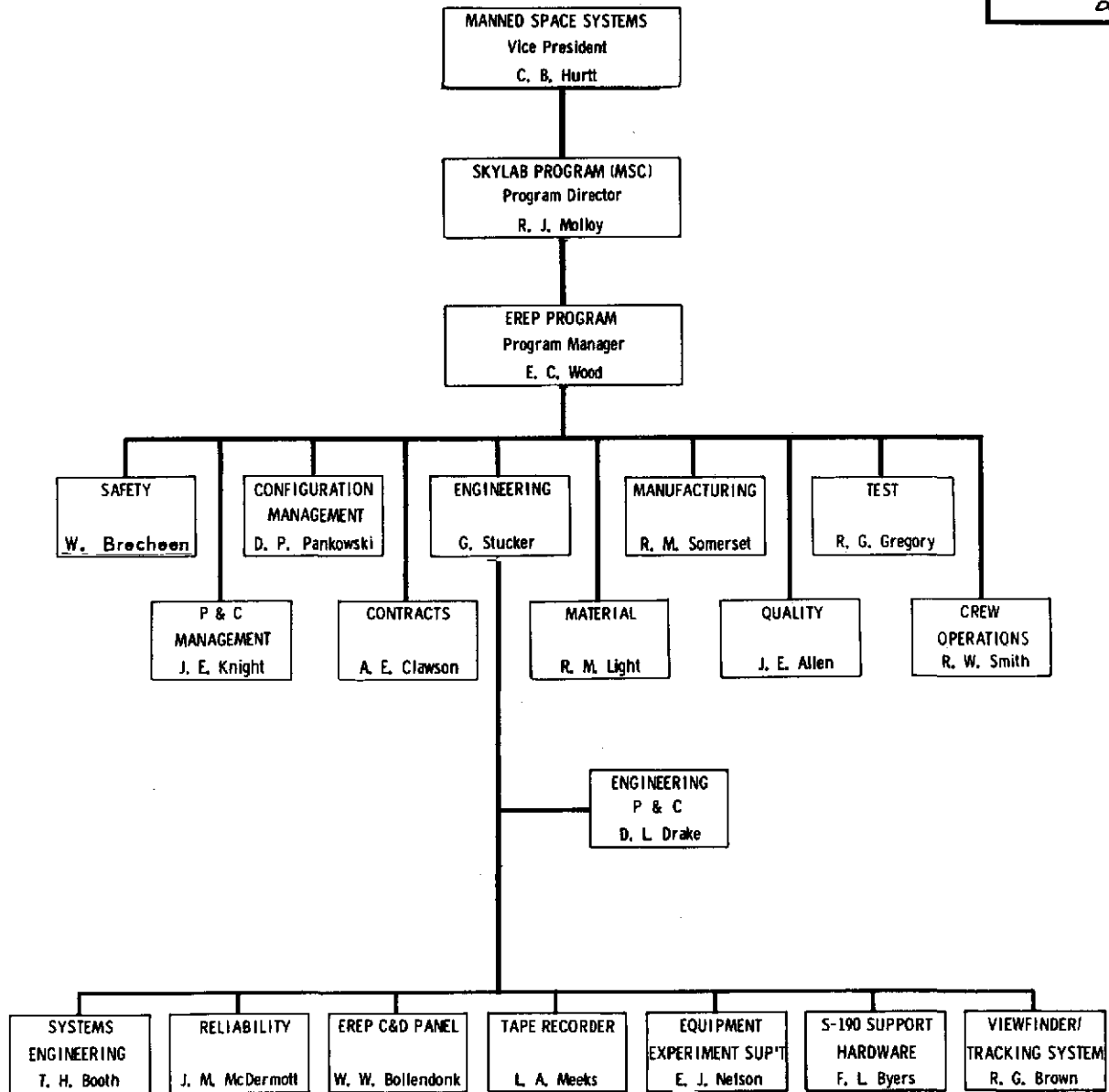

II. ARRANGEMENTS

The following general arrangements have been made for the EREP Critical Design Review. Questions that may arise before CDR concerning these arrangements may be directed to Dudley McCubbin or Tome Booth, phone (303) 794-5211, extension 4055 and 5011, Room 315 of the Space Support Building (SSB), Martin Marietta, Denver Division. After the CDR begins, any questions will be handled by available Martin Marietta personnel.

1. Registration and Badging

Special security badges will be required for all CDR attendees and will be issued upon your initial arrival at the Martin Marietta facility. Badges may be retained for the duration of the Review. Admission to the facility for subsequent sessions will be granted without delay providing all passengers in a car display their badges at the guard gate.

Registration will take place in the lobby of the SSB on Tuesday, December 8, between 10:00 and 11:00 am.

Upon reaching the Martin Marietta plant entrance, be prepared to stop. Advise the guard that you are participating in the EREP CDR. He will issue you a badge and allow you to proceed directly to the SSB reserved parking area.

2. Parking

Reserved parking will be available for all visitors attending the CDR. Parking areas are indicated on the facilities map and Martin Marietta security personnel will be on hand to aid attendees in locating parking. At registration, you will be provided a car pass authorizing use of reserved parking areas.

3. CDR Reception Center

A CDR Reception Center has been established in the ground floor lobby of the SSB to provide support and services to the attendee while he is in the Denver area. Facilities and services include:

- Secretaries will be available to provide assistance with messages, travel arrangements, lodging, etc;
- Telephones will be available for use by attendees;
- Mail services.

4. Review Team Meeting Locations

The EREP CDR will be held at the Martin Marietta's Denver Division facility. A Martin Marietta facilities map is included to aid the attendees in locating specific areas of interest at the Martin Marietta facility.

<u>Review Team</u>	<u>Building</u>	<u>Room</u>	<u>Telephone Extension</u>
Electronics	SSB	404	2844
Electrical	SSB	500-K	3867
Structural/Mechanical/Optical	SSB	Presentation Room	4854
Thermal	SSB	605	2447
Rel, QA, and Safety	SSB	505	4879
Mfg and Test	SSB	600-B	2400
Crew Station Review	SSB	310	5305
Special Meetings (as required)	SSB	616-A	4556

5. Review Material Handouts

Each review team member will receive an EREP CDR Data Package at registration, which includes the following:

- 1) Information and arrangements;
- 2) Telephone directory;
- 3) Drawing Tree;
- 4) PDR RID Status;

- 5) EREP hardware description;
- 6) Schedule;
- 7) Test program;
- 8) Fabrication plan.

In addition to the Data Package, the following documents will be available for reference:

- 1) EIS;
- 2) Interface documents;
- 3) Design criteria documents;
- 4) PDR RID status;
- 5) Released drawings with DCN's;
- 6) Experiment Requirements Documents (ERD's);
- 7) Technical reports;
- 8) Contractual data package;
- 9) EEE Parts Specification.

Attendees who desire additional Data Packages should request them upon arrival.

6. EREP Engineering Mockup

The MDA/EREP Engineering Mockup will be on display (see map) December 9 between 4:30 and 7:00 pm. All CDR attendees are invited and encouraged to inspect the mockup. Martin Marietta personnel will conduct a tour for Review Team Members during this time.

7. On-Site Transportation

For your convenience, shuttle buses operate between the SSB and the Engineering Building.

8. Reproduction Facilities

Xerox and blackline machines will be available for limited reproduction; your requests for this service will be handled by the Martin Marietta personnel.

9. Meals

Lunch is served at noon each day of the CDR in the cafeteria located on the second floor of the Engineering Building.

Food service is available from 6:30 to 7:15 pm in the cafeteria located on the first floor of the Engineering Building.

III. EREP CDR AGENDA

TUESDAY, DECEMBER 8, 1970

10:00 am - 11:00 am	Registration - Space Support Building (SSB) Lobby
10:30 am	Coffee and Doughnuts - Coffee Bar, 6th Floor, SSB
11:00 am - 12:30 pm	General Meeting - Presentation Room, 6th Floor, SSB
12:30 pm - 1:15 pm	Lunch
1:15 pm - 3:00 pm	General Meeting Continued
2:30 pm	Coffee and Doughnuts - Coffee Bar 6th Floor, SSB
3:00 pm - 5:00 pm	System Review
4:30 pm - 7:00 pm	EREP/MDA Engineering Mockup Walk-through

WEDNESDAY, DECEMBER 9, 1970

8:30 am - 12:00 pm	System Review Continued
10:00 am	Coffee and Doughnuts - Coffee Bar 6th Floor, SSB
12:00 pm - 1:00 pm	Lunch
1:00 pm - 2:00 pm	Preparation of RID's
2:00 pm	Coffee and Doughnuts - Coffee Bar, 6th Floor, SSB
	RID's Due to MMC

THURSDAY, DECEMBER 10, 1970

10:00 am - 5:00 pm

Pre-Board Meeting, Presentation
Room, 6th Floor, SSB

12:00 am - 1:00 pm

Lunch

10:00 am and 2:00 pm

Coffee and Doughnuts - Coffee Bar
6th Floor, SSB

FRIDAY, DECEMBER 11, 1970

8:30 am - 2:00 pm

Board Meeting, Presentation Room,
6th Floor, SSB

12:00 am - 1:00 pm

Lunch

10:00 am and 2:00 pm

Coffee and Doughnuts - Coffee Bar
6th Floor, SSB

GENERAL MEETING

TUESDAY, DECEMBER 8, 1970
PRESENTATION ROOM, SPACE SUPPORT BUILDING

NASA Chairman - R. Machell
MMC Responsibility - E. Wood

11:00 am	Opening Remarks	R. Machell
11:15 am	EREP System Overview	E. Wood
11:30 am	General Information	D. McCubbin
11:40 am	V/TS Functional Review	R. Brown
12:00 am	Tape Recorder Functional Review	L. Meeks
12:10 pm	ESE Functional Review	E. Nelson
12:20 pm	S190 Support Hardware Functional Review	L. Byers
12:30 pm	Lunch	
1:15 pm	C&D Panel Functional Review	W. Bollendonk
1:30 pm	Training Hardware Review	R. Smith
1:45 pm	Schedule Review	J. Knight
2:00 pm	Test Program	R. Gregory
2:15 pm	Fabrication Techniques	R. Somerset
2:30 pm	Coffee and Doughnuts	
2:45 pm	Review of Key Issues	G. Stucker
3:00 pm	Review Team Meetings	Chairmen

ELECTRONICS REVIEW TEAM



ROOM 404, SSB

NASA TEAM CHAIRMAN - C. JACKSON
MMC RESPONSIBILITY - W. BOLLENDONK

Tuesday, December 8

- 3:00 pm • Viewfinder/Tracking System
 - Design Status M. Hintze
 - Logic
 - PC Boards
 - Status of Interfaces W. Cox
 - Drawing Review M. Hintze
 - Discussion of Key Issues W. Bollendonk
- 4:30 pm • Control and Display Panel
 - Design Status W. Bollendonk
 - Logic
 - PC Boards
 - S190 Intorvelometer
 - Clock Drive
 - Status of Interfaces W. Cox
 - Drawing Review W. Bollendonk
 - Discussion of Key Issues W. Bollendonk

Wednesday, December 9

- 8:30 am • Tape Recorder
 - Design Status R. Ferguson
 - Logic
 - Status of Interfaces W. Cox
 - Drawing Review R. Ferguson
 - Discussion of Key Issues W. Bollendonk — Martin Lead

ELECTRICAL REVIEW TEAM

ROOM 500-K, SSB

NASA Team Chairman - P. Miglicco
MMC Responsibility - D. McCubbin

TUESDAY, DECEMBER 8

3:00 pm Viewfinder/Tracking System

1. Status of Design M. Hintze
 - a. Power Supplies
 - b. Circuit Protection
 - c. Cabling
2. Status of Electrical Interfaces W. Cox
3. Drawing Review M. Hintze
4. Discussion of Key Issues D. McCubbin

4:00 pm Tape Recorder

1. Status of Design R. Ferguson
 - a. Power Supplies
 - b. Circuit Protection
 - c. Cabling
2. Status of Electrical Interfaces W. Cox
3. Drawing Review R. Ferguson
4. Discussion of Key Issues D. McCubbin

WEDNESDAY, DECEMBER 9

8:30 am Control and Display Panel

1. Status of Design V. Patton
 - a. Power Supplies
 - b. Circuit Protection
 - c. Cabling
2. Status of Electrical Interfaces W. Cox
3. Drawing Review V. Patton
4. Discussion of Key Issues D. McCubbin

10:00 am RID Preparation
L. Dudley
- Conducted as on Tour.

STRUCTURAL/MECHANICAL/OPTICAL REVIEW TEAM

PRESENTATION ROOM - SSB

NASA Team Captain - L. Bernardi
MMC Responsibility - W. Hooker

TUESDAY, DECEMBER 8

3:00 pm

Structural/Mechanical System Overview W. Hooker

1. Hardware to be Reviewed
2. Drawing Release Status
3. Hardware Interfaces

Level A and B ICD Status R. Wyman

1. ESE to MDA and Scanner Electronics
2. Viewfinder to MDA and Spectrometer
3. S190 to MDA and ITEK

Structural Design Criteria A. Ripple

1. Criteria Philosophy
2. Vibration and Resonant Response
3. Acoustics and Shock
4. Loads and Load Factors

Stress Analysis Approach T. Sealman

1. Stiffness/Strength Criteria
2. Critical Stress Areas
3. Margins of Safety

4:00 pm

Viewfinder/Tracking System Design

1. Telescope W. O'Connor
2. External Structure and Mechanisms H. Miller
3. C&D Panel C. Anderson
4. Optics - Telescope, Cassegrain, etc. W. Casey

WEDNESDAY, DECEMBER 9

8:30 am	Tape Recorder Enclosure Design	N. Wobschall
	1. Cold Plates	
	2. Covers	
	3. Shock Mounts	
	Experiment Support Equipment Design	E. Nelson
	1. Racks	
	2. Wiring and Tubing	
	3. T/H Container	
	4. Shields and Covers	
	S190 Support Equipment Design	F. Byers
	1. Camera Mount	
	2. Shields	
	3. Stowage Containers	
	Control and Display Panel Design	R. Small
	1. Cold Plate	
	2. Logic and Power Supply Cases	
	3. Cover Assembly	
9:50 am	Discussion of Key Items	L. Bernardi
1:00 pm	RID Preparation	
2:00 pm	RID Submittal to MMC	

THERMAL REVIEW TEAM

ROOM 605, SSB

NASA Team Chairman - R. Frost
MMC Responsibility - D. Sousek

TUESDAY, DECEMBER 8

3:00 pm EREP Fluid Loop Description D. Sousek <

- a. Physical Description
- b. Schematic of Fluid Flow -
 Operation Modes
- c. Thermal Network
- d. Analytical Results
- e. Test Programs
- f. Drawing Review
- g. Discussion of Key Issues

WEDNESDAY, DECEMBER 9

8:30 am S191 Spectrometer Cooling Approach D. Sousek

- a. Physical Description
- b. Thermal Network
- c. Analytical Results
- d. Drawing Review
- e. Discussion of Key Issues

RELIABILITY, QUALITY ASSURANCE, SAFETY REVIEW TEAM

ROOM 505, SSB

NASA Team Chairman - G. House
MMC Responsibility - J. McDermott
- W. Brecheen
- J. Allen

TUESDAY, DECEMBER 8

3:00 pm	Reliability	J. McDermott
	1. Discuss Failure Mode, Effects Analysis	
	2. Discuss EEE Parts List	
	3. Present and Discuss EEE Parts Specifications	
	4. Present and Discuss EEE Parts Derating	
	5. Discuss Tape Recorder EEE Parts Retrofit Program	
	6. Discussion of Key Issues	
4:00 pm	Quality Assurance	
	Discussion of Key Issues	J. Allen
4:30 pm	Safety	
	Discussion of Key Issues	W. Brecheen

TEST AND MANUFACTURING REVIEW TEAM



ROOM 600-B, SSB

NASA TEAM CHAIRMAN - M. COODY
MMC RESPONSIBILITY - R. GREGORY
- R. SOMERSET

Tuesday, December 8

3:00 pm Test

R. Gregory

Status of:

- Development Test
- Acceptance and Qualification Procedures
- Integrated Bench Test
- SCN Impact on Test Program
- Acceptance V-Bration Test
- On-Module GSE
- Discussion of Key Issues

4:30 pm Manufacturing

Discussion of Key Issues

CREW STATION REVIEW

ROOM 310, SPACE SUPPORT BUILDING

NASA Team Chairman - D. Jacobs
MMC Responsibility - R. Smith

WEDNESDAY, DECEMBER 9

8:30 am

Pre-CSR

1:15 pm

CSR Walkthrough

THURSDAY, DECEMBER 10

10:00 am

CSR RID's Due to MMC

IV. REVIEW ITEM DISCREPANCY (RID) PREPARATION

- 1) Reviewer writes RID and submits to team chairman;
- 2) Team chairman reviews RID for clarity and completeness;
- 3) Team chairman submits RID to MMC;
- 4) MMC prepares contractors comments;
- 5) MMC will type RID, make viewgraph, and 10 copies;
- 6) Pre-board review;
- 7) Board review.

MAP

MARTIN MARIETTA
DENVER DIVISION

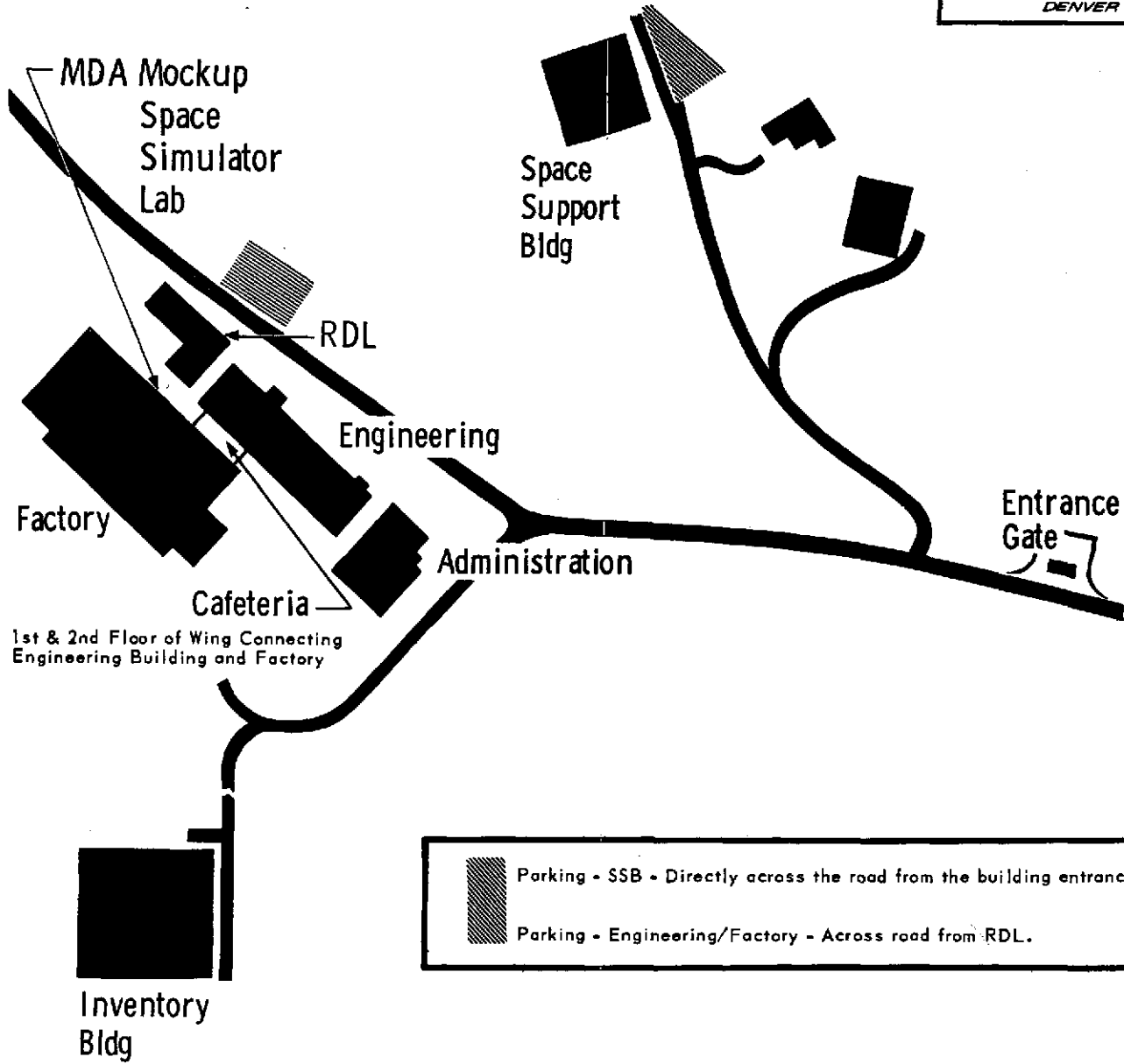

CDR TELEPHONE DIRECTORY

<u>Name</u>	<u>Title</u>	<u>Telephone</u> <u>303/794-5211</u> <u>Extension</u>
C. Hurtt	Vice President, Manned Space Systems	3141
R. Molloy	Skylab Program/MSC Director	2354
E. Wood	EREP Program Manager	2944
G. Stucker	EREP Engineering Project Manager	4801
R. Smith	Chief, Mission & Crew Operations	3791
T. Booth	Systems Engineering	5011
^{W. Kelly} D. McCubbin	PDR Presentation & Coordination	4055
L. Meeks	Tape Recorder Design	4356
E. Nelson	Experiment Support Hardware Design	5006
L. Byers	S-190 Support Hardware Design	5006
R. Brown	Viewfinder/Tracking System Design	3883
W. Bollendonk	C&D Panel Design	3035
J. McDermott	Reliability	4654
W. Brecheen	Safety	3062
D. Pankowski	Configuration Management	5115
A. Clawson	Contracts	4439
R. Somerset	Manufacturing	4019
J. Allen	Quality	3959
R. Gregory	Test	4214
A. Goldsby	Skylab Marketing	4170
W. Fruland	Public Relations	3895

RESIDENT NASA OFFICE

W. Davidson	2100
J. McCool	3579
A. Triche	4484
L. Lewandowski	3681
C. Quinn	3509
D. Clark - Secretary	2100

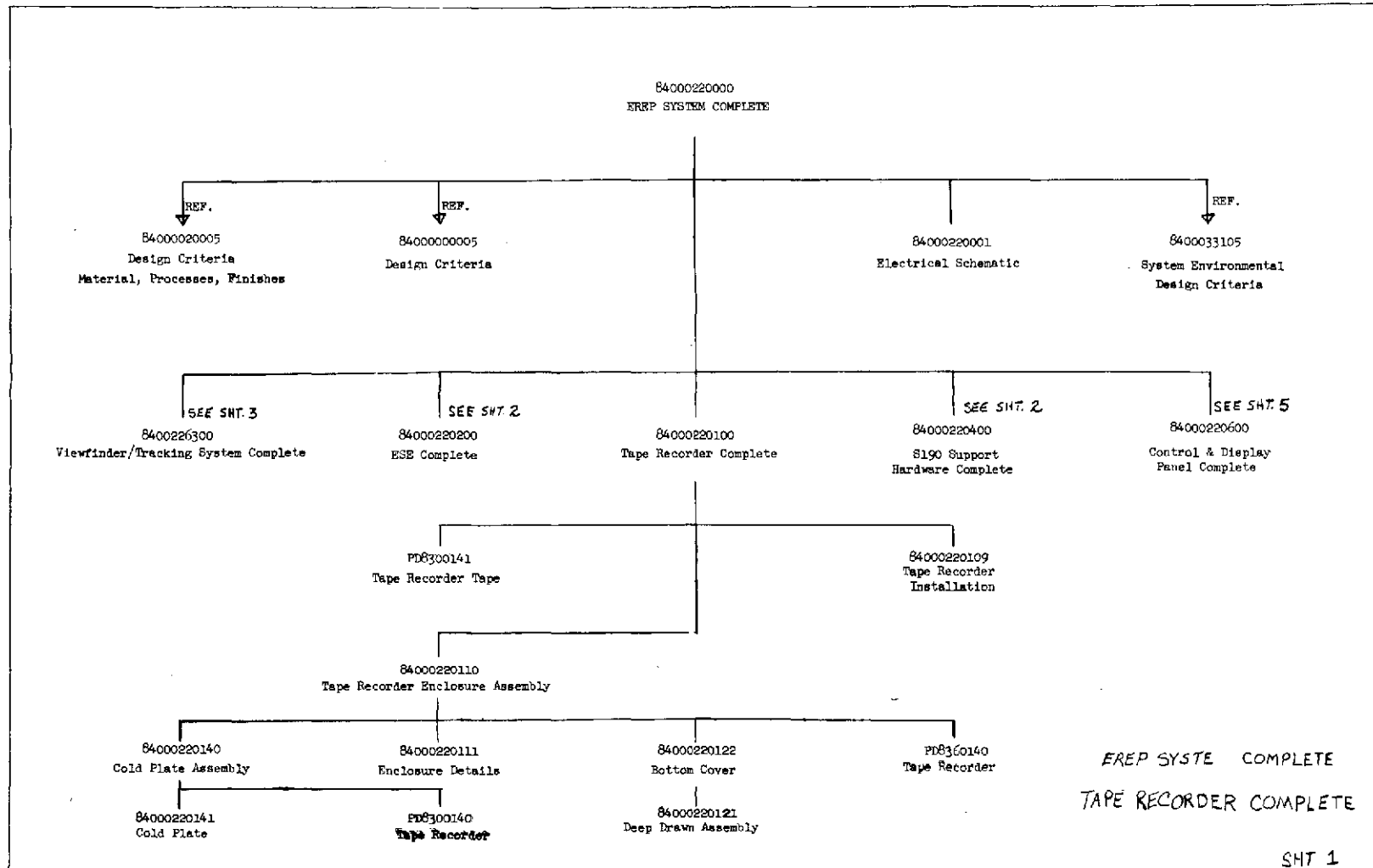

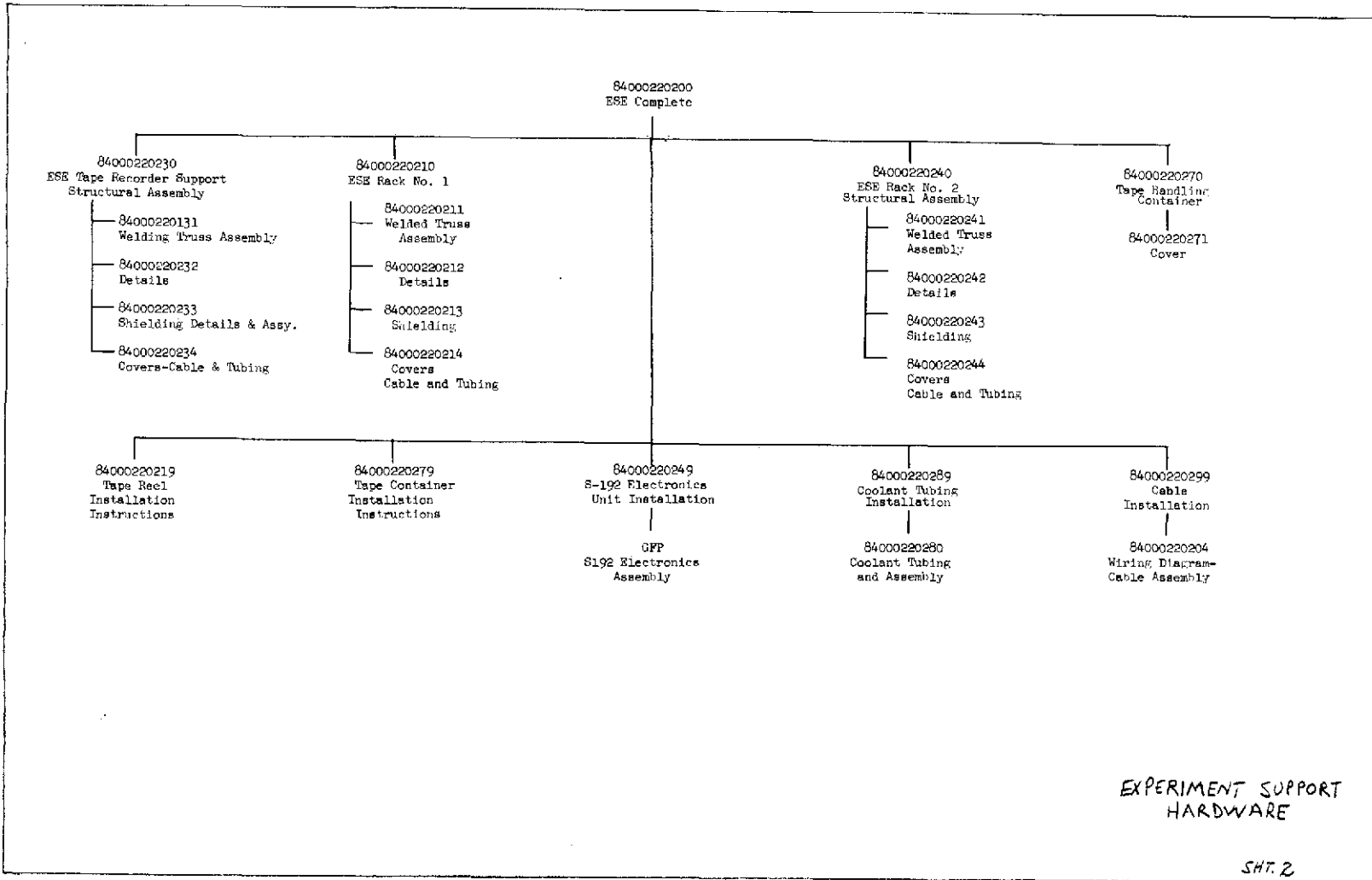

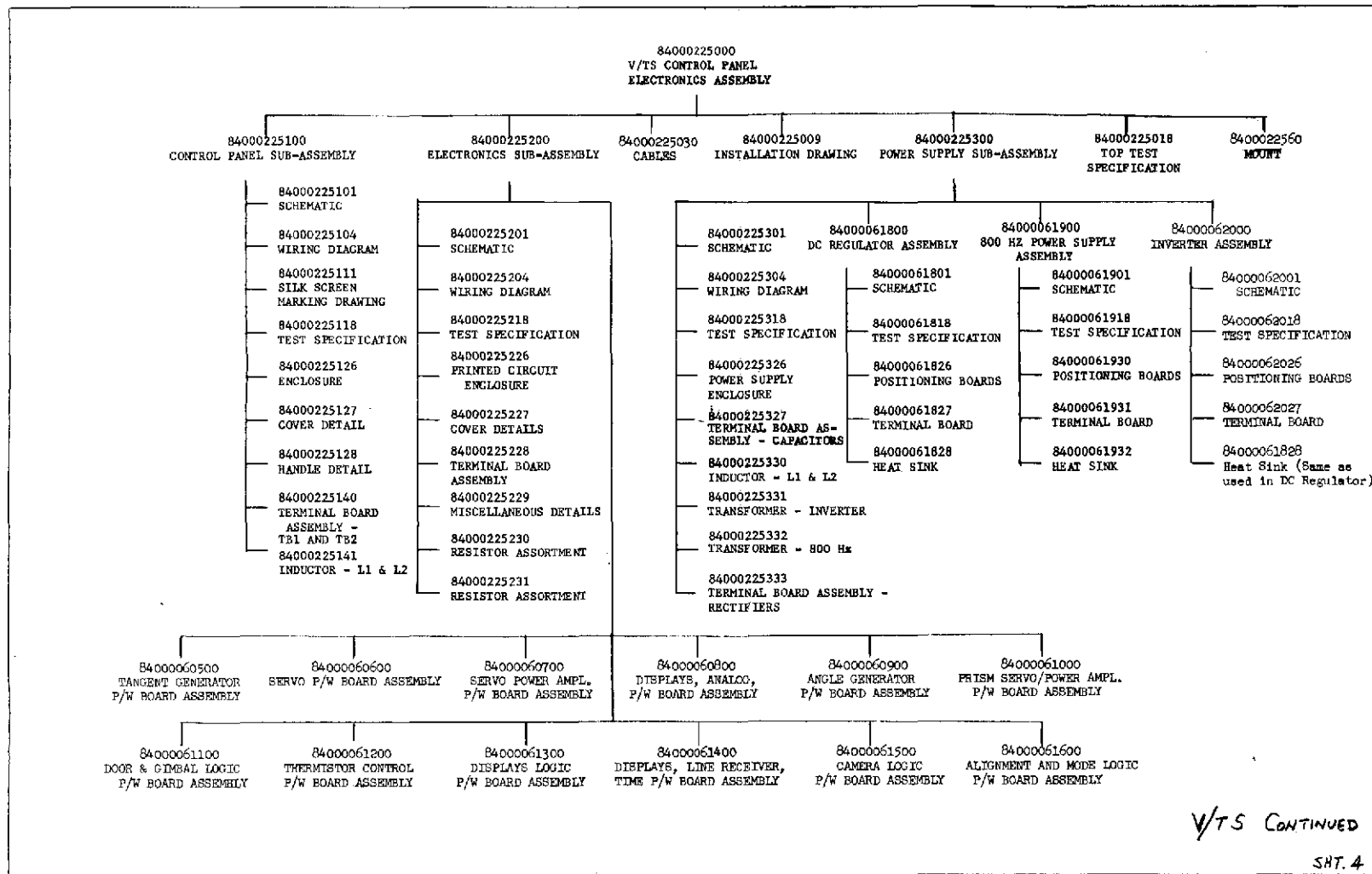

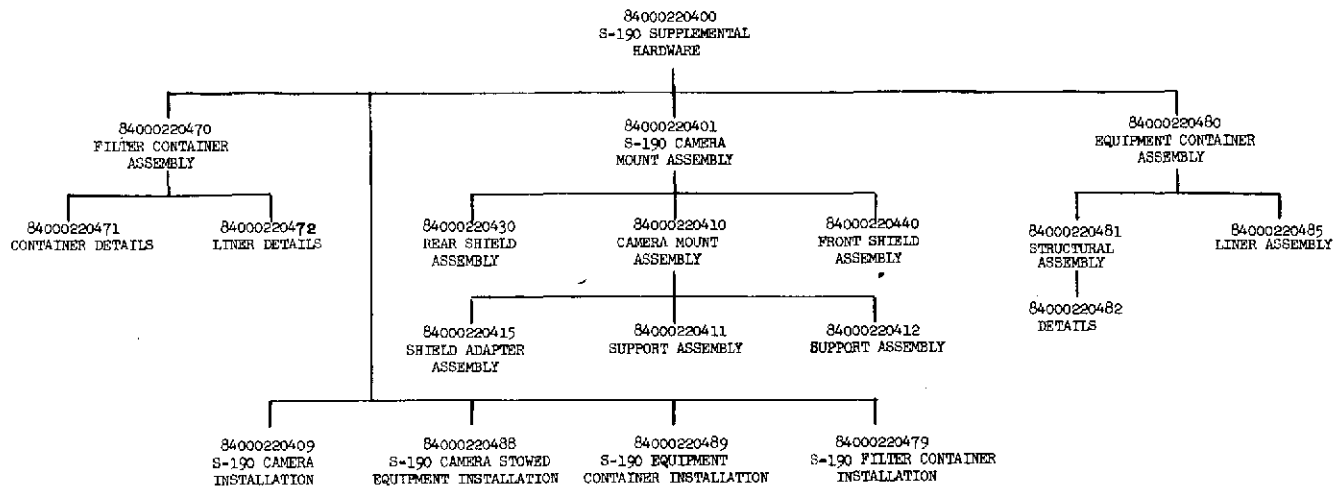

S190 SUPPLEMENTAL
HARDWARE

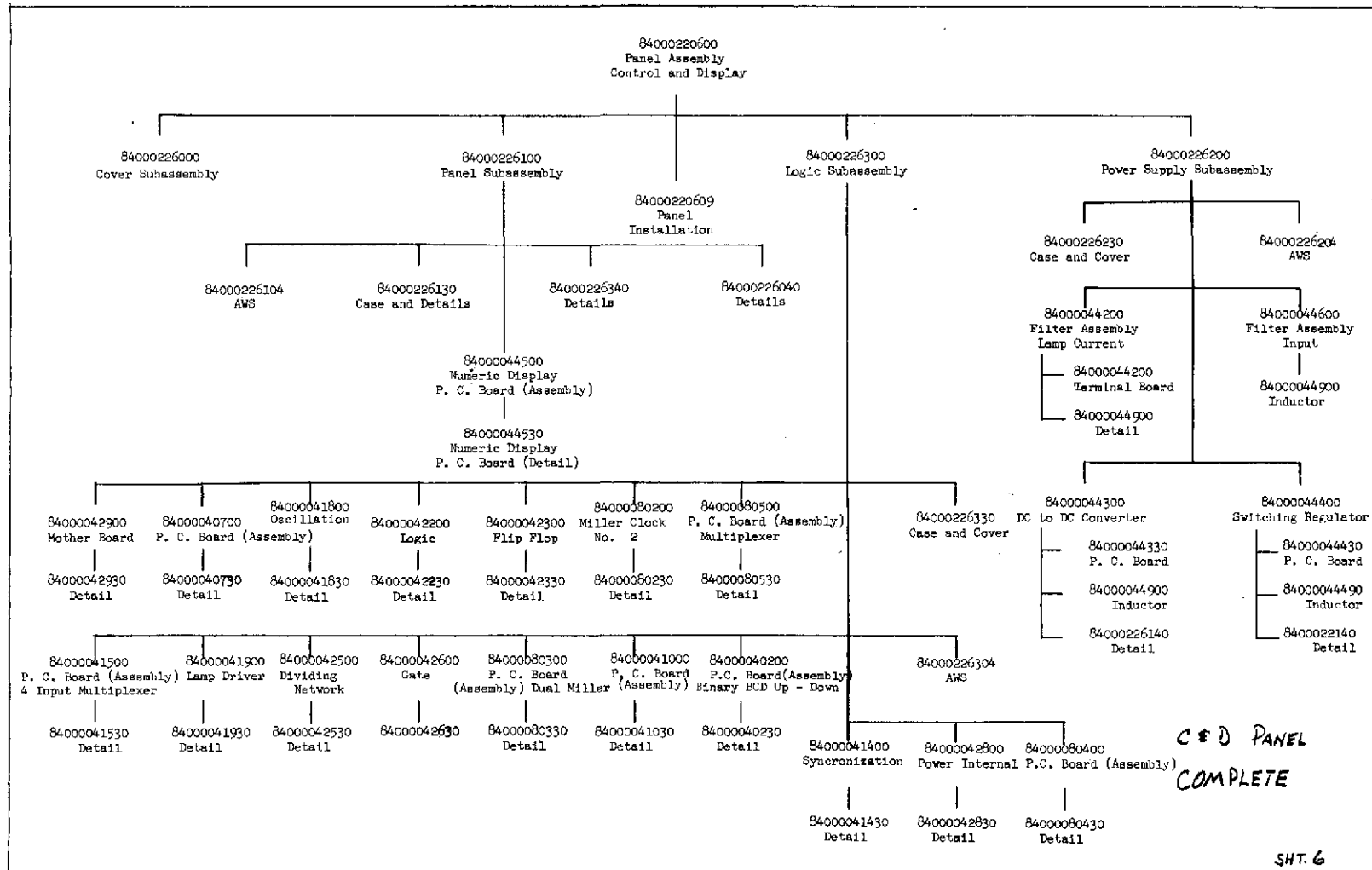

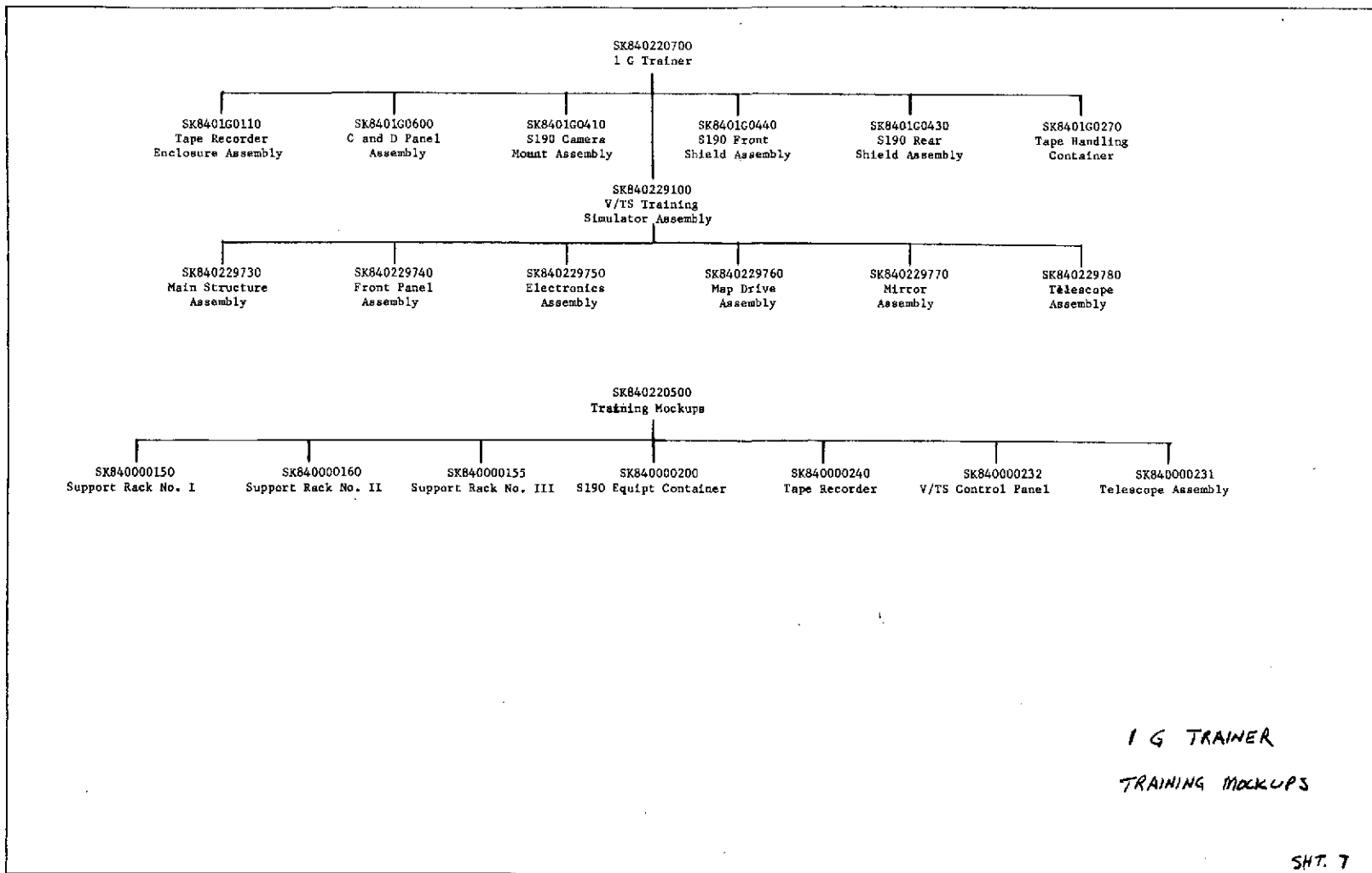

I G TRAINER
TRAINING MOCKUPS

PDR RID STATUS

WORKING GROUP

ESE (S-190)

NO.	DESCRIPTION	CATEGORY		SUSPENSE	FORM OF RESPONSE	REMARKS
		RID	EDCS ESE190	RESPONSIBILITY		
1	Tape Storage Container	A	1	10-16-70 Miller	EC 8020 Basic, Rev. EIS 01175	SCN 5 CLOSED
2	Storage for 2 Empty Tape Reels	A	1	10-23-70 Boothroyd	EC 8020 Supp A, Rev. EIS 01175	SCN #6-ECP802A-A220 Dated Oct. 6, 1970 CLOSED
3	S-190 Magazine Handle Container	A	2	10-23-70 Byers	EC 8020 Basic, Rev. EIS 01174 EC 8022 Basic, Rev. EIS 01175	SCN 5, SCN 9, SCN 4 CLOSED
4	Film Load Station	A	1	10-16-70 Byers	EC 8020 Basic, Rev. EIS 01175 EC 8022 EIS 01174	SCN 5 CLOSED
5	Fluid Interfaces with MDA	A	1	10-16-70 Nelson	EC 8020 Basic, Rev. EIS 01175	SCN 5 CLOSED
6	CM Environments	A	1	10-16-70 Byers/Nelson	EC 8020 Basic, Rev. EIS 01174 EC 8022 Basic, Rev. EIS 01175	SCN 4 SCN 5 CLOSED
7	Access For Changing Filters and Aperture Setting (S-190)	B	-	10-30-70 L. Byers	EC 8022 Supp D/Supp E PIRN to 13M12201	Submittal 2 December
8	Camera Shield Temporary Stowage	A	1	10-30-70 L. Byers	EC 8020 Basic, Rev. EIS 01174 EC 8022, Supp A MSC 01007	SCN 5 SCN 9 CLOSED
9	Camera Shield, Launch Stowage	A	1	10-23-70 L. Byers	EC 8020 Basic, Rev. EIS 01174 EC 8022, Supp A MSC 01007	SCN 5 SCN 9 CLOSED
10	Internal Window Cover Interface	D				
11	Cassette Handling Container	A	1	10-16-70 L. Byers	EC 8020 Basic, Rev. EIS 01175 EC 8022 Basic, Rev. EIS 01174	SCN 4 SCN 5 CLOSED

PDR RID STATUS

WORKING GROUP

ESE (S-190)

NO.	DESCRIPTION	CATEGORY		SUSPENSE	FORM OF RESPONSE	REMARKS
		RID	EDCS	RESPONSIBILITY		
"ESE"						
12	Deletion of CSM Trailing Capability	A	- 1	10-16-70 L. Byers	EC 8022 Supp A	SCN 9 CLOSED
13	Control Weight (S-190)	B	- 1	10-30-70 L. Byers	EC 8022 Basic, Rev. EIS 01174	SCN 4 CLOSED
14	Back-up Hardware	D	- -			
15	Add Means of Retarding Free Movement of S-190 Mount Support	F	-			
16	Air-Tight/Hermetically Sealed Tape Container	F	-			
17	Impact of Camera Front Shield & Protective Window	F	-			
18	Total MDA EREP Weight	B	-	10-10-70	MSC-KW	
19	Radiation Levels in the IDC	A	7	10-30-70 Nelson	EC 8020 Supp C, Rev. ICD 13M07397	SCN INCORPORATED CLOSED
20	Tape Recorder Handling Container	-	-			Closed

EARTH RESOURCES EXPERIMENT PACKAGE

PDR RID STATUS

WORKING GROUP

EREP Control & Display Panel

NO.	DESCRIPTION	CATEGORY		SUSPENSE	FORM OF RESPONSE	REMARKS
		RID	EDCS	RESPONSIBILITY		
1	Touch Temperature Limits	B	1	10-16-70 R. Small	EC 8023 Basic, Rev. EIS 01171	Spec Change Only SCN 11 CLOSED
2	Monitor Tape Remaining	A	-	/	Complied with by prior action.	Closed
3	Panel Cover	B	1, 7	10-30-70 R. Small W. Cox	EC 8023 Basic, Rev. EIS 01171 EC 8023 Supp F Rev ICD 13307397	Spec Change & IRN SCN 11 Submittal 18 December
4	Panel/Tape Recorder Cabling Capacitance	A	1	10-16-70 L. Meeks	Revise EIS T/R Input EC8019 Supp D	Spec Change Only
5	AM Timing	B	1	10-16-70 V. Patton	EC 8023 Basic, Rev. EIS 01171	Spec Change Only SCN 11 CLOSED
6	Fluid Interface	B	1	10-16-70 R. Small	EC 8023 Basic, Rev. EIS 01171	Spec Change Only SCN 11 CLOSED
7	S-193 Requirements	B	1	10-16-70 W. Bollendonk	EC 8023 Basic, Rev. EIS 01171	Spec Change Only SCN 11 CLOSED
8	S-190 Window Open Signal	A	-	10-30-70 W. Cox	/	W. Smoot/P. Miglicco No charge required Closed
9	C.G. of Panel	A	1	10-16-70 R. Small	EC 8023 Basic, Rev. EIS 01171	Spec Change Only SCN 11 CLOSED

NO.	DESCRIPTION	CATEGORY		SUSPENSE	FORM OF RESPONSE	REMARKS
		RID	EDCS	RESPONSIBILITY		
10	Maximum Envelope	B	7	10-30-70 R. Small	EC8020 Basic Rev EIS 01175	SCN 75 1 CLOSED
11	Radiation Levels	F	-			
12	MDA Decompression Rate	A	-		MSFC/MSC	Combine with TR-1 MSC Provide Correct Number to MMC.
13	Orbital Storage Thermal Limits	A	18	10-16-70 V. Patton	EC8023 Basic Revise EIS 01171	Spec Change No ICD Charge Required SCN 11 CLOSED
14	S-191 Requirements	A	-		Covered EIS	Closed
15	Tape Recorder/S192 High Speed Interface	F	-			Withdrawn
16	S-194 Requirements	B	1	W. Bollendonk	Revise EIS EC 8006 EC8006 Supp A, Rev. EIS 01171	Spec Change Only SCN #1 & #3 CLOSED
17	Mockup wires and plugs Exposed to Damage	A	1	10-16-70 R. Small		Released in Basic Engineering To Provide Mounting Holes For Cover CLOSED
18	Window Heater/S-190 Interlock	B	2,7	10-23-70 V. Patton	Submit ECP C EC 8023 Supp A, Rev. EIS 01171 ICD 1007 EC 8023 Supp A, F ICD 40M35673	Spec Change IRN Required Submittal 30 Nov. & 18 Dec.

PDR RID STATUS

WORKING GROUP

EREP Control & Display Panel

NO.	DESCRIPTION	CATEGORY		SUSPENSE	FORM OF RESPONSE	REMARKS
		RID	EDCS	RESPONSIBILITY		
* 19	Unprotected Coolant Lines	A	1	10-16-70 R. Small		Mounting Holes For Cover In Basic Release CLOSED
20	Antenna Alignment Control	F	-			Withdrawn
21	S-192 Calibration Switch	B	2,7	10-23-70 V. Patton	EC 8023 Supp AG Rev. EIS 01171 ICD 01009 IRN to ICD 40M35675 Required	Spec Change IRN Required Submittal 30 November
22	S-192 Diffuser Data Requirements	D	-			Disapproved
23	Alignment Marks on Connectors	F	-			Withdrawn
24	Working Group	A	-			MSC-KW Action
25	S-191 Source Select Switch	A	2	10-23-70 V. Patton	Submit ECP, IRN EC 8023 Supp AG Rev. EIS 01171 ICD 01008	Spec Change IRN Required
26	Monitor Measurements	A	-			MSC-S&AD Action
27	S-190 Ready Light	D	-			Disapproved
28	S-193 Scan Mode Switch	A	1	10-16-70 W. Cox		Spec Change IRN Required Submittal 30 November
29	S-190 Intervolometer Requirements Change	B	2	10-23-70 V. Patton W. Cox	Submit ECP, IRN EC 8023, Supp AG Rev. EIS 01171 ICD 01007	Spec Change IRN Required Submittal 30 November

PDR RID STATUS

WORKING GROUP

EREP Control & Display Panel

NO.	DESCRIPTION	CATEGORY		SUSPENSE	FORM OF RESPONSE	REMARKS
		RID	EDCS	RESPONSIBILITY		
30	S-193 Band Width & Pulse Width Switches	A	2, 7	10-30-70 V. Patton W. Cox	EC 8023 Supp A ^C , Rev. EIS 01171 ICD 01007 EC 8023 Supp B ^C ICD 40M35673	Submittal 30 November Submittal 18 December IRN to 40M35677 requires Revision by MSC
31	S-190 Malfunction Lights	A	3	10-16-70 R. Small	Will be incorporated in basic engineering	
32	Ready Light Logic	A	3	10-16-70 V. Patton	Will be incorporated in basic engineering	Incorporated CLOSED
33	S-193 Range Lock Light	A	2, 7	10-23-70 V. Patton W. Cox	Submit IRN ^C EC 8023 Supp A ^C , Rev. 01171, ICD 01010 EC 8023 Supp C, ICD 40M35673	Submittal 30 November
34	S-194 Calibration Switches	A	2	10-23-70 R. Small W. Cox	Submit IRN ^C EC 8023 Supp A ^C , Rev. EIS 01171 ICD 01016	Submittal 30 November IRN to 40M35677 required by MSC
35	S-193 Scan Angle	A	3	10-16-70 R. Small	Will be incorporated in basic engineering	Incorporated CLOSED
36	S-190 Dual Bus Power	D	-			Disapprove
37	Panel/Latches	B	2	10-23-70 R. Small	EC 8023 Supp A ^C , Rev. EIS 01171	Submittal 30 November
38	S-192 MODE SW/Tape Speed Control	D	-			Disapproved

PDR RID STATUS

WORKING GROUP

EREP Control & Display Panel

NO.	DESCRIPTION	CATEGORY		SUSPENSE	FORM OF RESPONSE	REMARKS
		RID	EDCS	RESPONSIBILITY		
39	Nomenclature	A	3	10-16-70 R. Small	Submit IRN EC8023 Supp F ICD 40M35673	Submittal 18 December
40	S-191 Source Select Switch	F	-			Withdrawn
41	S-193 Microwave Radiometer Rotaries	A	3	10-16-70 R. Small	Will Will be incorporated in basic engineering	Incorporated CLOSED
42	Tape Recorder Forward Switch	A	2	10-23-70 R. Small V. Patton	EC 8023 Supp ^C A, Rev. EIS 01171	
43	Malfunction Lights/S-193/S-194	A	3	10-16-70 W. Bollendonk		Inputs To Functional Descriptions Report For Next Control & Display Panel Mtg.
44	Overvoltage Conflict	A	1	10-30-70 W. Cox	EC 8023 Basic, Rev. EIS 01171	SCN 11 CLOSED

EARTH RESOURCES EXPERIMENT PACKAGE
PDR RID STATUS WORKING GROUP

Crew Station and
Training Hardware

NO.	DESCRIPTION	CATEGORY		SUSPENSE	FORM OF RESPONSE	REMARKS
		RID	EDCS	RESPONSIBILITY		
1	Flight Crew Training Equipment	A	-	/	MSC-KW	
2	Acceptance of Crew Training Hardware	A	-	/	MSC-KW	
4	Temporary Stowage for S-190 Covers	F	-	/	/	Withdrawn
6	S-190 Magazine Handling Container	B	-	MSFC		
7	Tape Recorder Coolant Lines	A	3	10-16-70 Nelson		Revision to EIS 01175 Pending
8	Tape Recorder Electrical Connectors	A	2	10-23-70 Bailey		Option D being implemented
9	Data "Clip Board"	A	2	10-23-70 R. Jenicek	EC 8021, Supp A EIS MSC-01176	Submittal 4 December
10	V/TS Camera "Pigtail"	A	-	MSC-KW		
11	Non-available Design	B	3	9-28-70	Letter 70Y-82,323 Attn: R. M. Machell/ KW	Required hardware will be available atCDR - CLOSED
12	MDA EMU	A	-	-Closed- MSFC		

NO.	DESCRIPTION	CATEGORY		SUSPENSE	FORM OF RESPONSE	REMARKS
		RID	EDCS	RESPONSIBILITY		
1	V/TS FMEA	B	1	11-24-70 J. McDermott	Incorporate for CDR	CLOSED
2	Failure Modes Not Detectable In Flight	D	-			
3	S-190 Optical Window - Rel.	F	-			
4	Radiation Effects on S-190 Glass	F	-			
5	S-190 Inner Window	F	-			
6	Crew Safety - Pressure Loss	F	-			

PDR RID STATUS

WORKING GROUP

TEST

NO.	DESCRIPTION	CATEGORY		SUSPENSE	FORM OF RESPONSE	REMARKS
		RID	EDCS	RESPONSIBILITY		
1	Flight Unit Acceptance Test	C	2	9-18-70 Gregory	ROM to MSC 9/18/70	Closed
2	Tape Recorder and C&D Coolant Lines	B	1	10-12-70 Gregory	Rev. Verification Plan EC 8044 Basic	EIS's To Be Revised on Receipt Of MSC Direction. Submittal 11 December
3	Integrated System Test	D	-			
4	Verification Plan - V/TS	A	1	10-12-70 Gregory	Rev. Verification Plan EC 8044 Basic	EIS's To Be Revised On Receipt Of MSC Direction. Submittal 11 December
5	Tape Recorder Verification	B	1	10-27-70 G. Robinett	Incorporate In Basic Release Of EITRS.	Complete 1 February
6	Acceptance Vibration Testing	C	-			Combine with T-1
7	Qualification for Mission Cycle	B	1	10-16-70 Gregory	Rev. Verification Plan EC 8044 Basic	EIS's To Be Revised On Receipt Of MSC Direction. Submittal 11 December
8	Verification of Minimum Useful Life	A	1	10-12-70	Rev. Verification Plan EC 8044 Basic	EIS's To Be Revised On Receipt of MSC Direction. Submittal 11 December
9	Tape Recorder and C&D Panel Test	A	2	10-23-70 Gregory	EC 8023, Supp C, Rev. MSC 01171 EC 8019, Suppl A, Rev. MSC 01173	Submittal 30 November
10	Functional Checks During Environmental Acceptance	A	1	1-7-71 Gregory	Incorporate In Basic Release Of Procedures	Complete 15 January

PDR RID STATUS

WORKING GROUP

Tape Recorder

NO.	DESCRIPTION	CATEGORY		SUSPENSE	FORM OF RESPONSE	REMARKS
		RID	EDCS	RESPONSIBILITY		
1	Decompression Rate	A	2	10-23-70 R. Bailey	EC 8019 Supp A, Rev. EIS 01173 & PD8300140	Submittal 30 November
2	Coolant/Fluid Interfaces	A	1	10-16-70 R. Bailey	EC 8019 Basic, Rev. EIS 01173	SCN 10 CLOSED
3	Relative Humidity Requirement	B	1	10-16-70 R. Bailey	EC 8019 Basic, Rev. EIS 01173	SCN 10 CLOSED
4	Location of Magnetic Tape	B	1	10-16-70 R. Bailey	EC 8019 Basic, Rev. EIS 01173	SCN 10 CLOSED
5	Induced Magnetic Fields	A	1, 7	10-16-70 R. Bailey	EC 8019 Basic, Rev. EIS 01173	SCN 10 CLOSED
6	Fire Extinguishing Provisions	D	-	MSC/KT		
7	Include Tape in MIL-E-461	A	1	10-16-70 R. Bailey	EC 8019 Basic, Rev. EIS 01173	SCN 10 CLOSED
8	Flight Vehicle Interfaces	F	-			
9	Space Empty Tape Reels	F	-			
10	Control Weight of Return Tape	F	-			
11	Over and Under Voltage Conflict	A	1,7	10-16-70 R. Bailey	EC 8019 Basic, Rev. EIS 01173 & PD 8300140	SCN 10 CLOSED

PER RID STATUS

WORKING GROUP

Tape Recorder

NO.	DESCRIPTION	CATEGORY		SUSPENSE	FORM OF RESPONSE	REMARKS
		RID	EDCS	RESPONSIBILITY		
12	Coolant System Reliability	D	-			
13	EMI Environments	D	-			
14	End of Tape Indicator	A	2	10-23-70 R. Bailey	EC 8019 Supp A, Rev. EIS 01173 & PD8300140	Submittal 30 November
15	Tape Recorder Voice Capability	D	-			
16	IRIG-A Time Code	D	-			

EARTH RESOURCES EXPERIMENT PACKAGE

PDR RID STATUS

WORKING GROUP

Viewfinder/Tracking System

NO.	DESCRIPTION	CATEGORY		SUSPENSE	FORM OF RESPONSE	REMARKS
		RID	EDCS	RESPONSIBILITY		
1	Time As Single-Point Partial Failure	D	-	/	/	/
2	Numerical Display Spillover	F	-	/	/	/
3	Telescope Installation	A	3	11-16-70 Brown	ICD to Level A (MDA) Personnel ERD Rev. Req'd	Requirements for evacuation & filling of MDA cavity submitted for Level A ICD input 26 Oct.
4	Telescope Protection	A	2	10-23-70 Brown	EC 8021, Supp A, EIS 01173	Tech. concurrence of Crew and Proj. office obtained 2 Nov. Proj. office OD required
5	Natural Thermal Limits In Orbit	F	-	/	/	/
6	Thermal Interface	A	1	10-16-70 Brown	EC 8021, Basic, EIS 01176	Submittal 4 December
7	Telescope Thermal Analysis	A	3	11-16-70 Sousek		
8	Telescope Alignment	A	3	11-16-70		Closed
9	Baffles	D	-	/	/	/
10	Opticals Coatings	A	3	11-16-70		Closed
11	Dirty Glass	A	2	10-23-70 Brown	EC 8021, Supp A, EIS 01173	Submittal 4 December

EARTH RESOURCES EXPERIMENT PACKAGE

PDR RID STATUS

WORKING GROUP

Viewfinder/Tracking System

NO.	DESCRIPTION	CATEGORY		SUSPENSE	FORM OF RESPONSE	REMARKS
		RID	EDCS	RESPONSIBILITY		
12	Zoom Optics	A	3	11-16-70 R. Dennen		
13	Image Brightness	A	5	11-13-70 Brown	EC 8021, Basic, Study EC 8021, Supp C	Submittal 4 December Submitted 18 November
14	Telescope Image	D	-			
15	Image Rotation Prism Servo	A	5	11-16-70 Brown	EC 8021, Basic, Study EC 8021, Supp C	Submittal 4 December Submitted 18 November
16	Image Jitter	A	5	11-16-70	EC 8021, Basic, Study EC 8021 Supp C	Submittal 4 December Submitted 18 November
17	Derotation Jitter	F	-			
18	Camera Frame Rates	D	-			
19	Dedicated Camera	C	5	10-16-70 J.C. Jones W. Casey	Response submitted 10 Oct 70 by IDC to S&AD(Demel) EC 8021 Supp E	CLOSED
20	Operational Camera/Film/Magazine	B	-		MSC/KT	
21	Filtration Requirement	A	5	11-2-70 W. Casey	Response via IDC to S&AD EC 8021 Supp C	CLOSED
22	Alignment Specification	C	5	10-16-70 J.C. Jones	Response via IDC To S&AD(Demel)	CLOSED
23	Alignment Display	A	1	10-16-70 Brown	EC 8021, Basic, EIS 01176	
24	Tracking Requirements	A	1	10-16-70 Brown	EC 8021, Basic, EIS 01176	Submittal 4 December

EARTH RESOURCES EXPERIMENT PACKAGE

PDR RID STATUS

WORKING GROUP

Viewfinder/Tracking System

NO. / "γ"	DESCRIPTION	CATEGORY		SUSPENSE	FORM OF RESPONSE	REMARKS
		RID	EDCS	RESPONSIBILITY		
25	MDA Decompression Rate	B	-		MSFC/KW	
26	Skylab Component Requirements	F	-			Closed - SCN #3 15/9/70
27	Maximum Magnification	C	5	11-13-70 R. Dennen	Study originally to be submitted on 16 Oct 70 Decision on type of eyepiece needed from MSC	Closed - SCN #16 11/16/70
28	Mirror Reflectances	A	1	10-16-70 Brown		Closed - SCN #3 15/9/70
29	Collimator in Cassegrain	A	1			Closed - SCN #2 1/7/70
30	Pickoff Mirror	A	1	10-16-70 Brown		Closed - SCN #3 15/9/70
31	V/TS EIS - Mirror Specification	A	1	10-16-70 Brown		Closed - SCN #3 15/9/70
32	V/TS EIS - Update Mirror Assembly	A	1	10-16-70 Brown		Closed - SCN #3 15/9/70
33	V/TS EIS - Update Panel	A	1	10-16-70 Brown	EC 8021, Basic, EIS 01176	Submittal 4 DEcember
34	V/TS EIS - V/H Ratio	A	1	10-16-70 Brown	EC 8021, Basic, EIS 01176	Submittal 4 DEcember
35	V/TS EIS - Reflectivity	A	1	10-16-70 Brown	EC 8021, Basic, EIS 01176	Submittal 4 DEcember
36	V/TS EIS - f/no.	A	1	10-16-70 Brown	EC 8021, Basic, EIS 01176	Submittal 4 DEcember

EARTH RESOURCES EXPERIMENT PACKAGE

PDR RID STATUS

WORKING GROUP

Viewfinder/Tracking System

NO.	DESCRIPTION	CATEGORY		SUSPENSE	FORM OF RESPONSE	REMARKS
		RID	EDCS	RESPONSIBILITY		
37	V/TS EIS - Eye Relief	A	5	11-13-70 R. Dennen	Same as V-27 EC 8021 Supp C	Closed - SCN #16
38	V/TS EIS - I.O.S.	A	1	10-16-70 Brown	EC 8021, Basic, EIS 01176	Submittal 4 December
39	V/TS EIS - Sun Elevation	D	-			
40	Design Criteria Document	B	4	10-30-70 R. Jenicek	EC 8021 Supp B 10/16/70 Rev.	SCN #14 Closed
41	V/TS Receptance Testing	A	-			Closed
42	Integrated Testing	A	-	9/30/70	MSC/KT	
43	Integrated Testing	B	-	10/9/70 Brown	MSC/KT	
44	Electrical Connector Update	F	-			
45	Spectrometer Collimation Light	F	-			
46	Power Limit	F	-			
47	TBD's in Drawing	A	7	10/9/70 J.C. Jones	EC 8021 Supp C MSC 01008	Submittal 4 December
48	Environment Specification	A	7	10-9-70 J.C. Jones	EC 8021 Supp C MSC 01008	Submittal 4 December
49	Meteoroid Impact Design	C	2	10-23-70 Brown	Submitted via ICD to S&AD(Demel)	CLOSED
50	S191 Cooler	F	-			

EARTH RESOURCES EXPERIMENT PACKAGE

PDR RID STATUS

WORKING GROUP

Viewfinder/Tracking System

NO.	DESCRIPTION	CATEGORY		SUSPENSE	FORM OF RESPONSE	REMARKS
		RID	EDCS	RESPONSIBILITY		
51	Prelaunch Access To Hardware	A	1	10-16-70 Brown	EC 8021, Basic, EIS 01176	Submittal 4 December
52	S191 Cable Length	A	7	10-9-70 J.C. Jones	EC 8021, Supp C MSC 01008	Submittal 4 December
53	Level "B" Temperature Interface	A	7	10-9-70 J.C. Jones	EC 8021, Supp C MSC 01008	Submittal 4 December
54	S191 Sensor Shock Specification	A	7	10-9-70 J.C. Jones	EC 8021, Supp C MSC 01008	Submittal 4 December
55	S191 Alignment System	A	7	10-9-70 J.C. Jones	EC 8021, Supp C MSC 01008	Submittal 4 December
56	V/TS Control Panel	F	-			
57	Auto Cal Sequence	A	7	10-9-70 Brown	W. Bollendonk EC 8023	
58	Auto Cal Sequence	A	7	10-9-70 Brown	W. Bollendonk EC 8023	
59	Reflectance of Mirrors	A	7	10-9-70 J.C. Jones	MSC 01008 EC 8021 Supp C	Submittal 4 December
60	Alignment Light Time Constant	A	1	10-9-70 J.C. Jones	EC 8021 Supp C MSC 01008	Submittal 4 December
61	Environmental Constraints	A	3	10-13-70 W. Casey	Response by IDC to S&AD(L. TILTON) 30 November	Closed
62	Night Measurements	C	6	11-1-70 J.C. Jones		Submittal 4 December
63	Operation Constraints	A	2	10-23-70 J.C. Jones	Response by ICD to S&AD(Demel) 2 Oct. 70	CLOSED

PDR RID STATUS

WORKING GROUP

Viewfinder/Tracking System

NO.	DESCRIPTION	CATEGORY		SUSPENSE	FORM OF RESPONSE	REMARKS
		RID	EDCS	RESPONSIBILITY		
64	Natural Light Levels	B	1	10-16-70 Brown	EC 8021, Basic, EIS 01176	Submittal 4 December
65	MDA Voice Interface	D	-			
66	Flight Crew Interfaces	A	1	10-16-70 R. Smith	EC 8021 - Basic EIS 01176	Submittal 4 December
67	Two Axis Controller	F	-			
68	V/TS Door Failure	D	-			
69	Gimbal Alignment Procedure	A	3	12-1-70 K. Villyard		
70	Assume Mirror Caging	A	5	12-1-70 K. Villyard		
71	V/TS Gimballed Mirror	A	5	12-1-70 K. Villyard		
72	Gimbal Torque	A	3	11-15-70 K. Villyard		
73	Contamination	B	1	10-16-70 Brown	EC 8021, Basic, EIS 01176	Submittal 4 December
74	V/TS Contamination	B	5	1-15-71 J.C. Jones	Response by IDC to S&AD(Demel) 2 Oct 70	CLOSED
75	Switch Wicketts	A	-			Closed
76	Resolution	B	5	11-13-70 Jones/Casey/Dennen	Response by IDC to S&AD(Demel) 19 Oct 70	CLOSED SCN #16

NO.	DESCRIPTION	CATEGORY		SUSPENSE	FORM OF RESPONSE	REMARKS
		RID	EDCS	RESPONSIBILITY		
77	V/TS Handrest/Restraint	A	3	10-16-70 Hintze	EC 8021, Supp A	Submittal 4 December
78	Verification Plan	A	-	10-15-70	MSC/KT	

EREP TAPE RECORDER CONFIGURATION

INTRODUCTION

This configuration description dated 1 December 1970 replaces and supplants any previous configuration descriptions issued prior to the above date.

DESIGN CONCEPT

The EREP Tape Recorder System is a spaceborne high performance magnetic tape record/reproduce system for use on the EREP program to record scientific and performance evaluation data from the experiments of the EREP. These data are recorded onto magnetic tape for eventual return to earth. The tape recorder system is to be implemented using an Ampex Model AR728 airborne recorder. To meet the special requirements of operating and storage in an oxygen rich environment, certain materials must be changed (upgraded) for toxicity and flammability reasons. The existing top and bottom covers will be replaced by Martin Marietta-supplied top and bottom covers that attach to the Ampex main casting to form a flame containment environmental enclosure. For heat removal, Martin Marietta will add a liquid (water) cooled cold plate. This cold plate (water jacket) will be part of an EREP-dependent active liquid cooling loop. Martin Marietta will provide a vibration and shock isolation system that, in conjunction with quick release electrical connectors, water jacket fittings, and the recorder's isolator mounting attachments will facilitate removal and replacement of the recorder. The Martin Marietta-supplied top cover (part of the housing) will provide crew access to load and unload magnetic tape reels and to perform record head cleaning.

RECORDER SUB-UNIT ITEMS

1. Flight Hardware

Flight equipment for WBS Number 2201 is subdivided as follows and corresponds to Paragraph 3.1.1 of the EIS Number MSC-01173, Rev. A.

Item a. Basic Recorder (Buy) - This is to be Ampex AR 700 configured for 28 tracks. This item is to be procured under Martin Marietta Procurement Drawing PD8300140.

Item b. Environmental Enclosure (Make) - This is to be a Martin Marietta "Make" as described in Attachment 1.

Item c. Magnetic Tape (Buy) - This is to be 20 reels of type 3M 888 magnetic tape procured under Martin Marietta Procurement Drawing Number PD8300141.

HARDWARE UNITS, QUANTITY AND USE

1. There shall be six tape recorder units as follows:
 - 1 - Engineering Evaluation Unit, Breadboard Use - (Non-deliverable test unit received June 19 and returned September 9, 1970)
 - 1 - Design Development Unit (Nondeliverable)
 - 2 - Flight Units, Deliverable
 - 1 - Flight Unit Spare, Deliverable
 - 1 - Flight Backup Unit, Deliverable (Qualification Use and refurbished as required for backup use)
2. The two flight units will be mounted in the MDA with one in Rack 2 and one in Rack 3.
3. The first flight unit delivered will consist of:
 - Item a. Basic Recorder AR728 as modified by PD8300140 mounted into Item b. below.
 - Item b. Martin Marietta built Tape Recorder Environment housing.
 - Item c. Flight Magnetic Tape (20 reels to be delivered).

4. The second flight unit delivered shall be the flight backup unit and is identical to the first flight unit except less magnetic tape shall be installed in Rack 3.
5. The third flight unit delivered shall be the flight unit spare and is identical to the first flight unit except less magnetic tape shall be installed.
6. The fourth flight unit delivered shall be the flight back-up unit. This unit shall be like the flight unit spare except that it shall first be subjected to Qualification Tests and refurbishment as required.
7. Nondeliverable recorder units will be built to vendor part number and will not have toxicity and flammability materials upgrading. The design development recorder unit will be mounted in an environmental enclosure and tested in accordance with the design development test plan.
8. The 28-track development unit will have high degree of form, fit, function, and mass properties fidelity and will be suitable for design, development dynamics, environmental testing, and EMC testing; however, it will not be subjected to the 100 percent oxygen test or the 0.5 psia orbital storage requirement.

ATTACHMENT 1

TAPE RECORDER ENCLOSURE CONFIGURATION DESCRIPTION

The tape recorder environmental system consists of three separate subsystems:

1. The cover - top and bottom halves and latching mechanisms;
2. Cooling subsystem - cold plates plus sealing surfaces for the cover halves;
3. Shock isolation subsystem.

A drawing of the system is shown in Figure 1.

The cover consists of two halves - top and bottom - that are designed for flame containment in the event of a tape recorder fire. The enclosure is vented to permit controlled outgassing of the combustion products. The cover is designed to withstand a differential pressure of + 3 psid.

The buildup for the cover is as follows:

- a) Cold plate channels are attached to the tape recorder chassis casting;
- b) The top and bottom frames are bolted to the channels;
- c) The bottom cover is bolted to its frame;
- d) The top cover, since it must be opened is hinged and latched to its frame.

The cold plates consist of aluminum channels, to which aluminum tubing is brazed. These plates cover all four sides of the tape recorder chassis. The jointing of the tubes at the corners is accomplished by mechanical fittings.

Details of the cover/cold plate/tape recorder interfaces, latches and seals are shown on Figure 2.

Shock isolation is provided by Lord mounts that are attached to the side of the tape recorder.

ATTACHMENT 2

WBS 2201 TAPE RECORDER ENCLOSURE
LIST OF PRODUCTION DRAWINGS

1. ENCLOSURE INSTALLATION, EREP TAPE RECORDER 84000220109
2. ENCLOSURE ASSEMBLY, TAPE RECORDER 84000220110
3. CHASSIS-COLD PLATE ASSEMBLY 84000220140
4. COLD PLATE ASSEMBLY, TAPE RECORDER 84000220141
5. BOTTOM COVER MODIFICATIONS 84000220122
6. DEEP DRAWN ASSEMBLY, TAPE RECORDER ENCLOSURE 84000220121
7. ENLCOSURE DETAILS, TAPE RECORDER 84000220111

ATTACHMENT 3

FLIGHT MAGNETIC TAPE

The magnetic tape will be 1-inch wide wound in 7200 foot lengths on reels 12.5 inches in diameter. The reels will be nontapered, heavy precision reels to provide maximum protection of the tape during handling and when subjected to lift off and reentry stresses.

The tape will be 3M 888. It will be specially processed to PD 8300141

AR-700 TAPE RECORDER ENCLOSURE

MARTIN MARIETTA
DENVER DIVISION

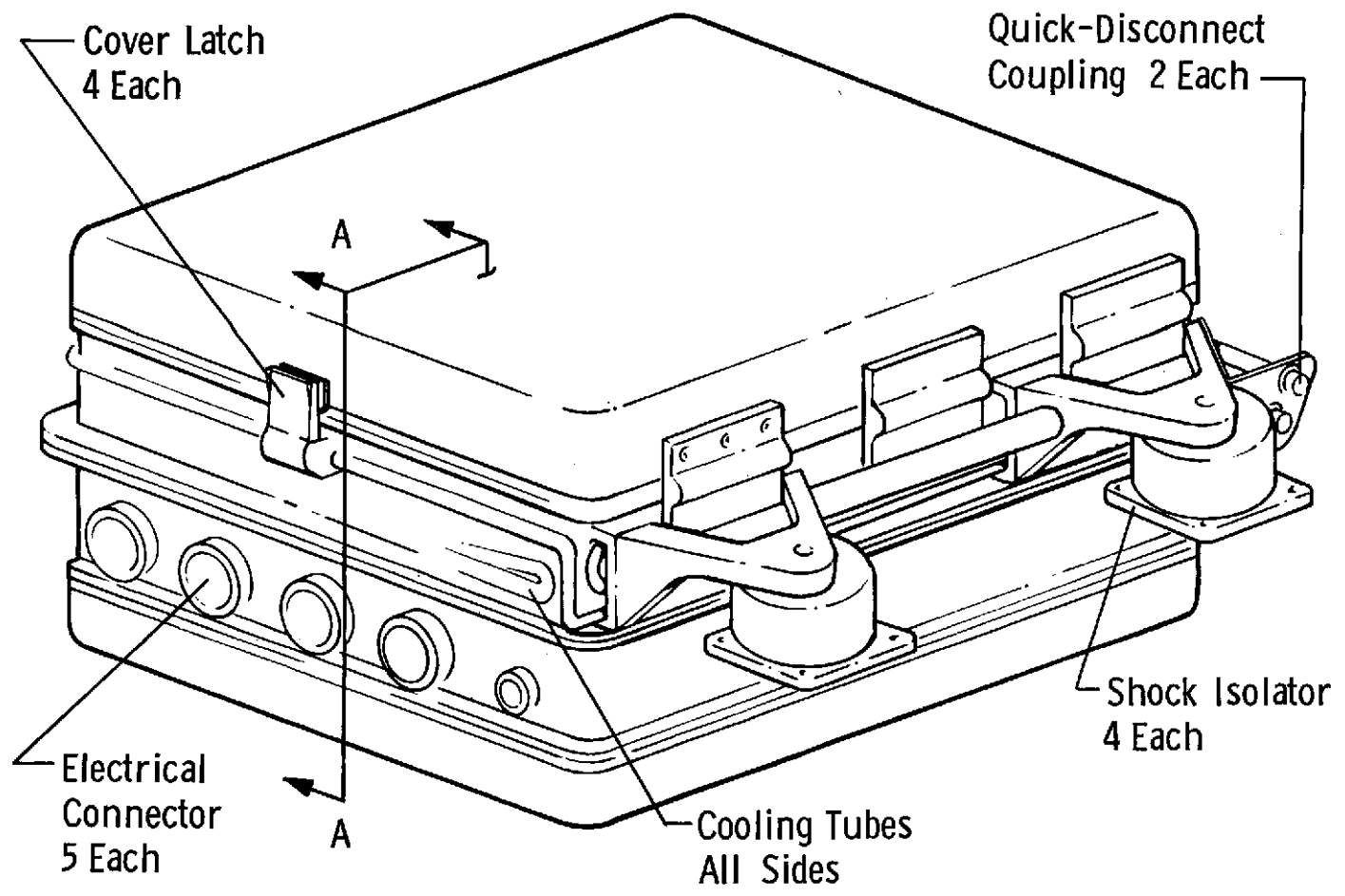

SECTION A-A OF ENCLOSURE

MARTIN MARIETTA
DENVER DIVISION

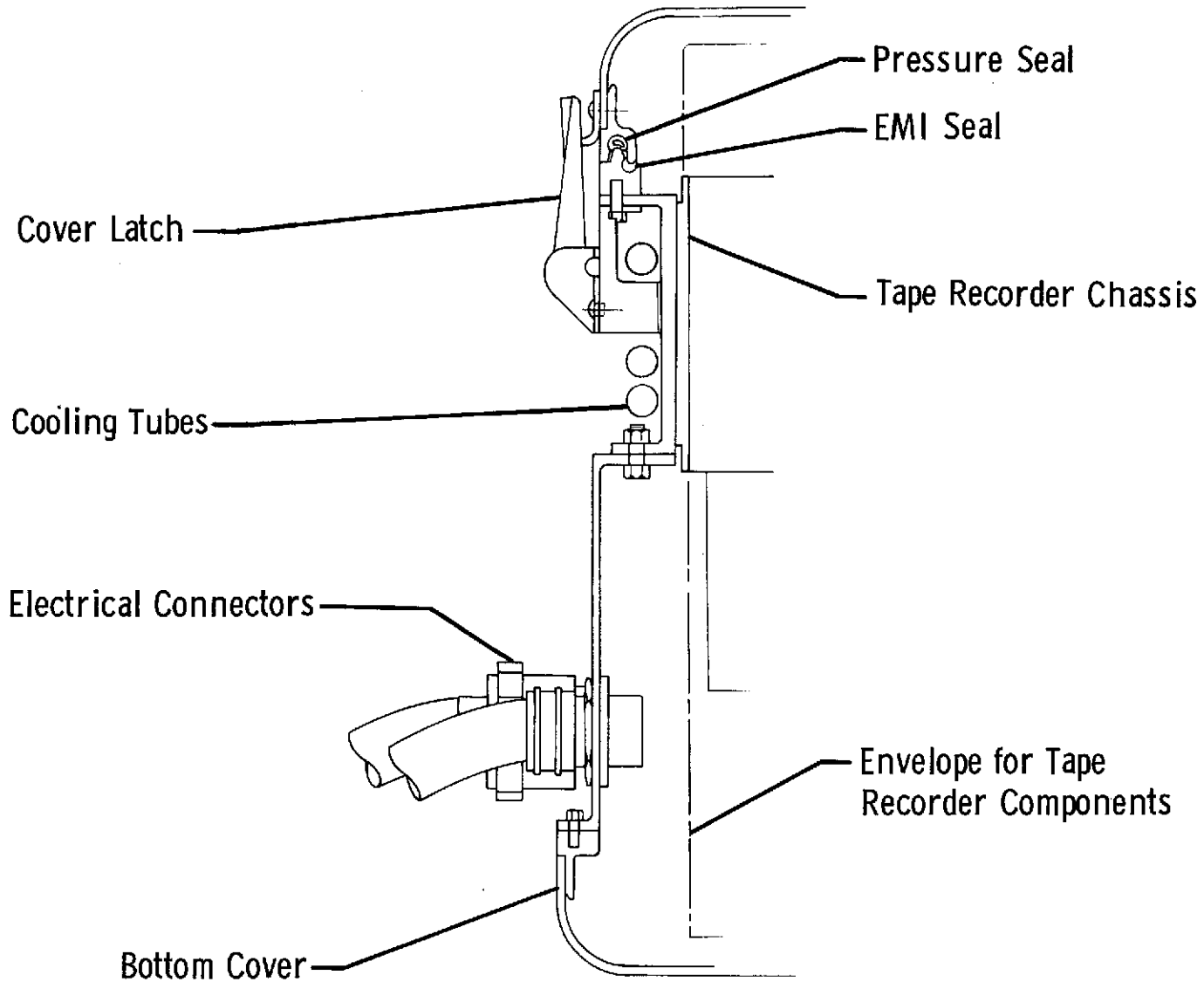

EREP/ESE EQUIPMENT

MARTIN MARIETTA

DENVER DIVISION

- TWELVE (12) MAGNETIC TAPE HANDLING CONTAINERS
- TWO (2) EQUIPMENT SUPPORT RACKS
- ONE (1) SPARE TAPE RECORDER SUPPORT
- INTERCONNECTING CABLES
- INTERCONNECTING COOLANT ASSEMBLY

MAGNETIC TAPE HANDLING CONTAINER - REQUIREMENTS

MARTIN MARIETTA

DENVER DIVISION

CONSTRAINTS

Specification Weight Limit 4 lb

Support of a Reel of Tape for All Operational and Stowage Conditions

Prevents Spreading of Flame Outside of Container

Adaptable to One Hand Carrying by a Single Crew Member

PERFORMANCE

Designed to Withstand a Decompression Rate of 8.7 psi in 50 sec

Designed to Withstand a Steady State Acceleration Load of 20 g's

Designed to Protect the Tape from Stray Magnetic Fields

INTERFACES

Interfaced with the CM

EQUIPMENT RACK NO. 1 REQUIREMENTS



CONSTRAINTS

- Specification Weight Limit 60 lb
- Space Limitation within the MDA
- Structural Compatibility with the MDA

PERFORMANCE

- Supports the C&D Panel, Cables, and Fluid Assembly Interconnections
- Designed to Protect the EREP Equipment for the Conditions of Steady State and Dynamic Loading

INTERFACES

- Structurally and Mechanically Interfaced with the MDA by Simple Mechanical Fasteners, Ref ICD 13M07397

EQUIPMENT RACK NO. 2 REQUIREMENTS

CONSTRAINTS

- Specification Weight Limit 98 lb
- Space Limitation within the MDA
- Structural Compatibility with the MDA

PERFORMANCE

- Supports the EREP Tape Recorder, the Scanner Electronics, the S190 Equipment Container, Interconnecting Cables and Coolant Assembly
- Designed to Protect the EREP Equipment for the Conditions of Steady State and Dynamic Loading

INTERFACES

- Structurally and Mechanically Interfaced with the MDA by Simple Mechanical Fasteners, Ref 13M07397
- Structurally and Mechanically Interfaced with the Scanner Electronics by Mechanical Fasteners, Ref MSC 01009

SPARE TAPE RECORDER SUPPORT REQUIREMENTS



CONSTRAINTS

- Specification Weight Limit 60 lb
- Space Limitation within MDA and Crew Access
- Structural Compatibility with MDA

PERFORMANCE

- Supports Spare Tape Recorder, Cables and Coolant Assembly
- Designed to Protect the Tape Recorder for the Conditions of Steady State and Dynamic Loading

INTERFACES

- Structurally and Mechanically Interfaced with the MDA by Simple Mechanical Fasteners, Ref ICD 13M07397

EREK LIQUID COOLING REQUIREMENTS



PERFORMANCE CONSTRAINTS

- 220 lb/hr Minimum Flow Rate with Maximum Allowable ΔP of 2 psid.
- Operating Pressure 37.2 psig (Hardware Design 50 psig)
- Fluid Temp. Range (+40°F) to (+83°F)
- Maximum Allowable EREP Heat Rejection to Fluid ~800 Btu/hr
- Allowable Fluid Leakage 0.5 cc/day
- Cleanliness per MSC-SPEC-C-8 (EPS 50405)

INTERFACE

- MDA Coolant EREP ICD 13M07397
- EREP Coolant for S192 Scanner Electronics Assembly MSC-01009

EXPERIMENT SUPPORT EQUIPMENT TRUSS STRUCTURE



DESIGN GROUND RULES IMPOSED ON TRUSS STRUCTURE

- Natural Frequency of Truss Shall Be Greater Than 60 cps
- A Minimum Wall Thickness of $t = 0.049$ in. is Required to Assure Weld Quality
- Minimum Weight Optimization of Each Truss Member is Utilized Within the Constraints of Minimum Weld Gauge and Weld Zone Material Allowable

MATERIAL PROPERTIES; 6061-T6511 TUBING

-T6511 Allowables	Weld Zone (4 or More Intersecting Tubes)
$F_{tu} = 42,000$ psi	$F_{tu} = 16,000$ psi
$F_{cy} = 35,000$ psi	$F_{ty} = 10,000$ psi
$F_{BRU} = 88,000$ psi ($\frac{E}{D} = 2.00$)	$F_{cy} = 10,000$ psi
$F_{BRY} = 58,000$ psi ($\frac{E}{D} = 2.00$)	$F_w = 12,000$ psi

MMC-EPS55406, FUSION WELDING OF ALUMINUM ALLOYS, SHALL BE APPLICABLE IN ALL WELD AREAS

EXPERIMENT SUPPORT EQUIPMENT RACKS

MARTIN MARIETTA

DENVER DIVISION

FACTORS OF SAFETY

- Ultimate Load Will Be Limit Load Times 3.0 for Basic Structure
- Yield Load Will Be Limit Load Times 2.0 For Basic Structure
- Material Allowable Design Stresses are as Defined by MIL-HDBK-5A.
Reduced Allowables Will Be Used in Weld Zones to Account for Heat Effects.

LOADS

- MDA Wall Mounted Environment is Applicable. The Truss Support Assemblies Shall Be Hard Mounted to the MDA Wall
- Table I Gives the Limit Load Factors Used in Analysis

EXPERIMENT SUPPORT EQUIPMENT TRUSS STRUCTURE



*LIMIT LOAD FACTORS (g's)

	Steady State	Vehicle Dynamics	Random X	Random Y	Random Z
Rack No. 1	-1.2 Long. 0 Lateral	+0.45 Long. +0.42 Lateral	+13.5	+15.4	+16.1
Rack No. 2	-1.2 Long. 0 Lateral	+0.45 Long. +0.43 Lateral	+ 7.18	+ 7.28	+ 8.70
Spare Tape Recorder Support	-1.2 Long 0 Lateral	+0.45 Long. +0.43 Lateral	+12.6	+12.6	+12.6

*Liftoff Conditions Gives Critical Loads

EREP HANDLING CONTAINER-TAPE

MARTIN MARIETTA
DENVER DIVISION

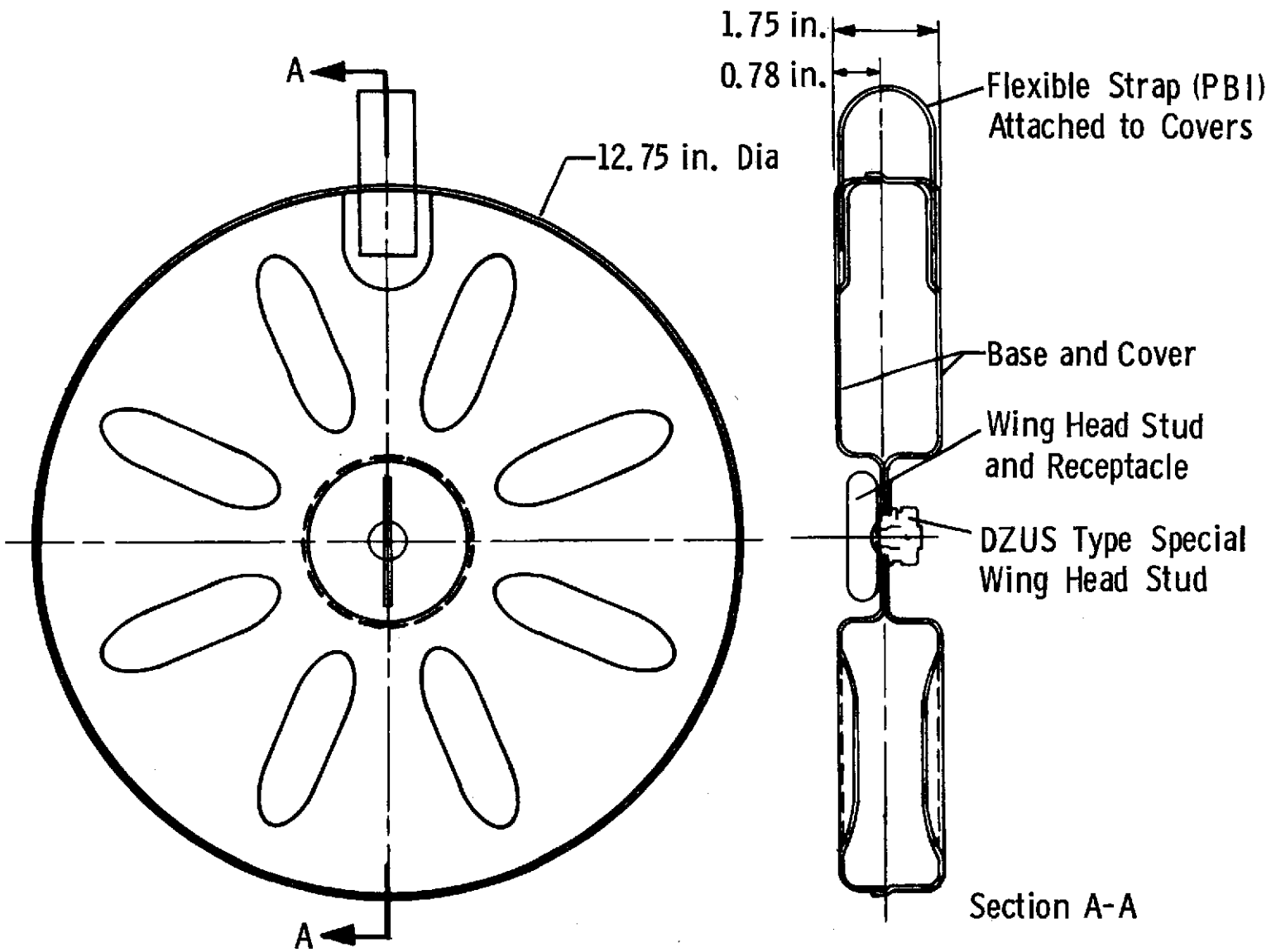

EXPERIMENT SUPPORT EQUIPMENT RACK NO. 1 GEOMETRY

MARTIN MARIETTA
DENVER DIVISION

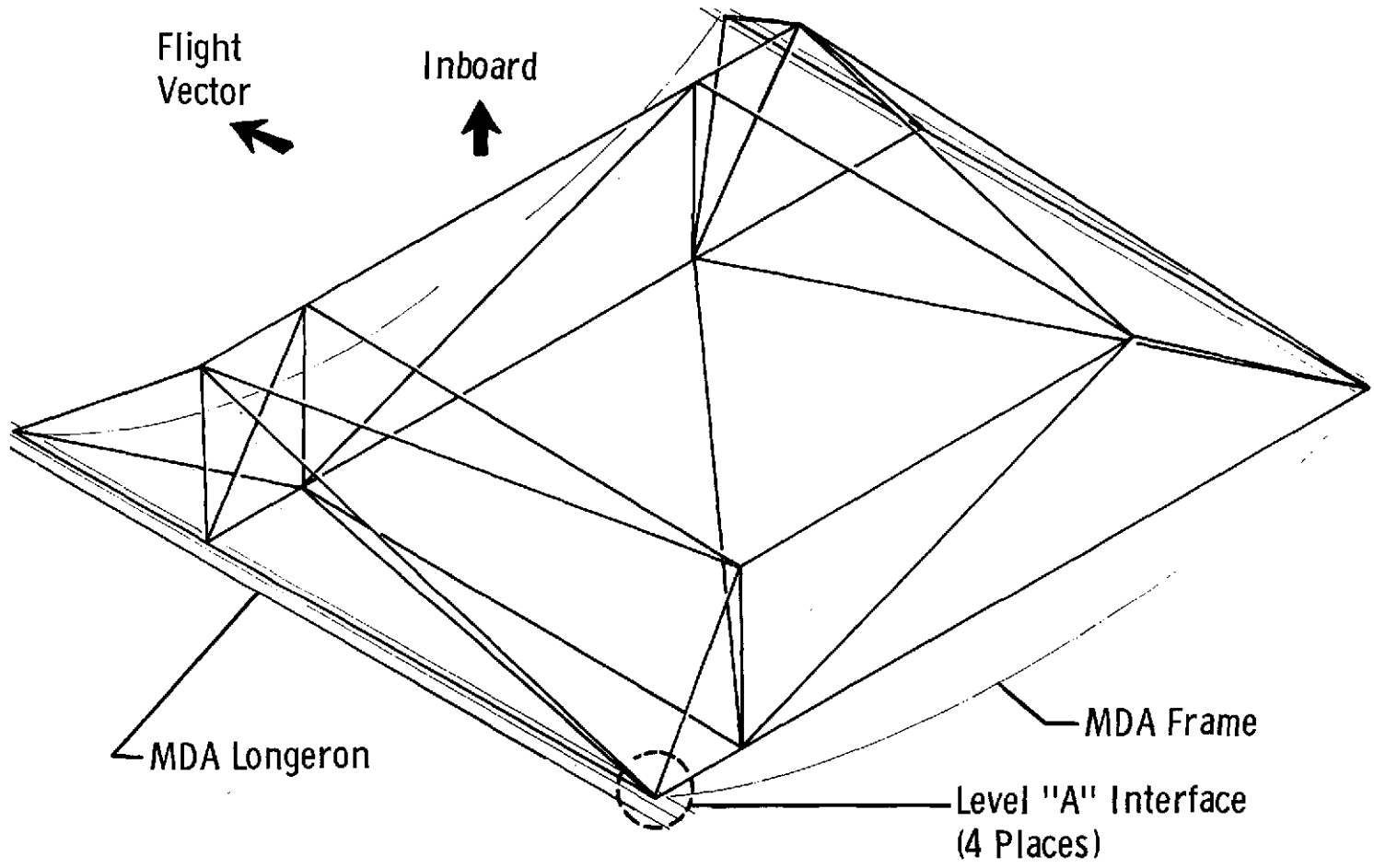

EXPERIMENT SUPPORT EQUIPMENT RACK NO. 1

MARTIN MARIETTA
DENVER DIVISION

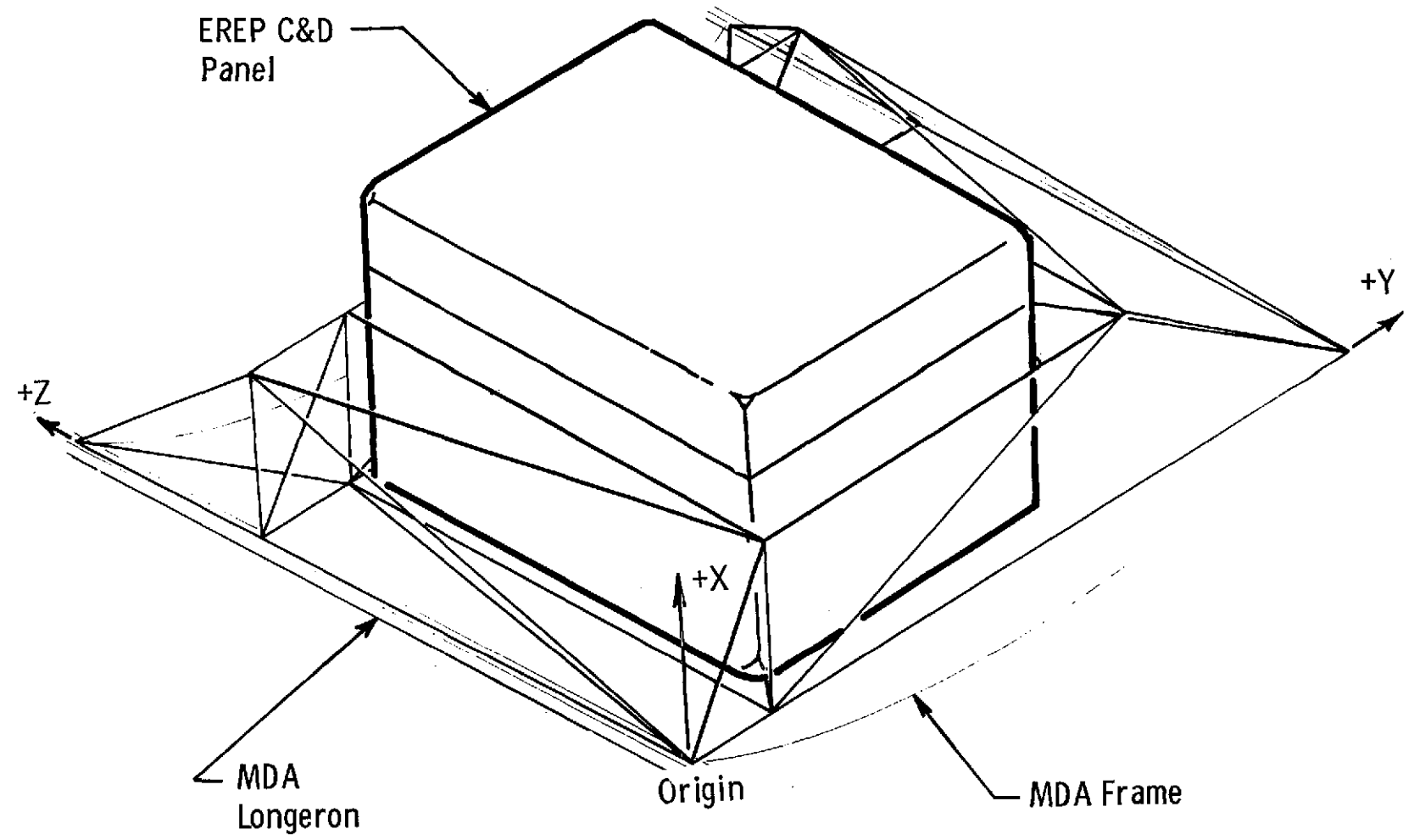

EXPERIMENT SUPPORT EQUIPMENT RACK NO. 2 GEOMETRY

MARTIN MARIETTA
DENVER DIVISION

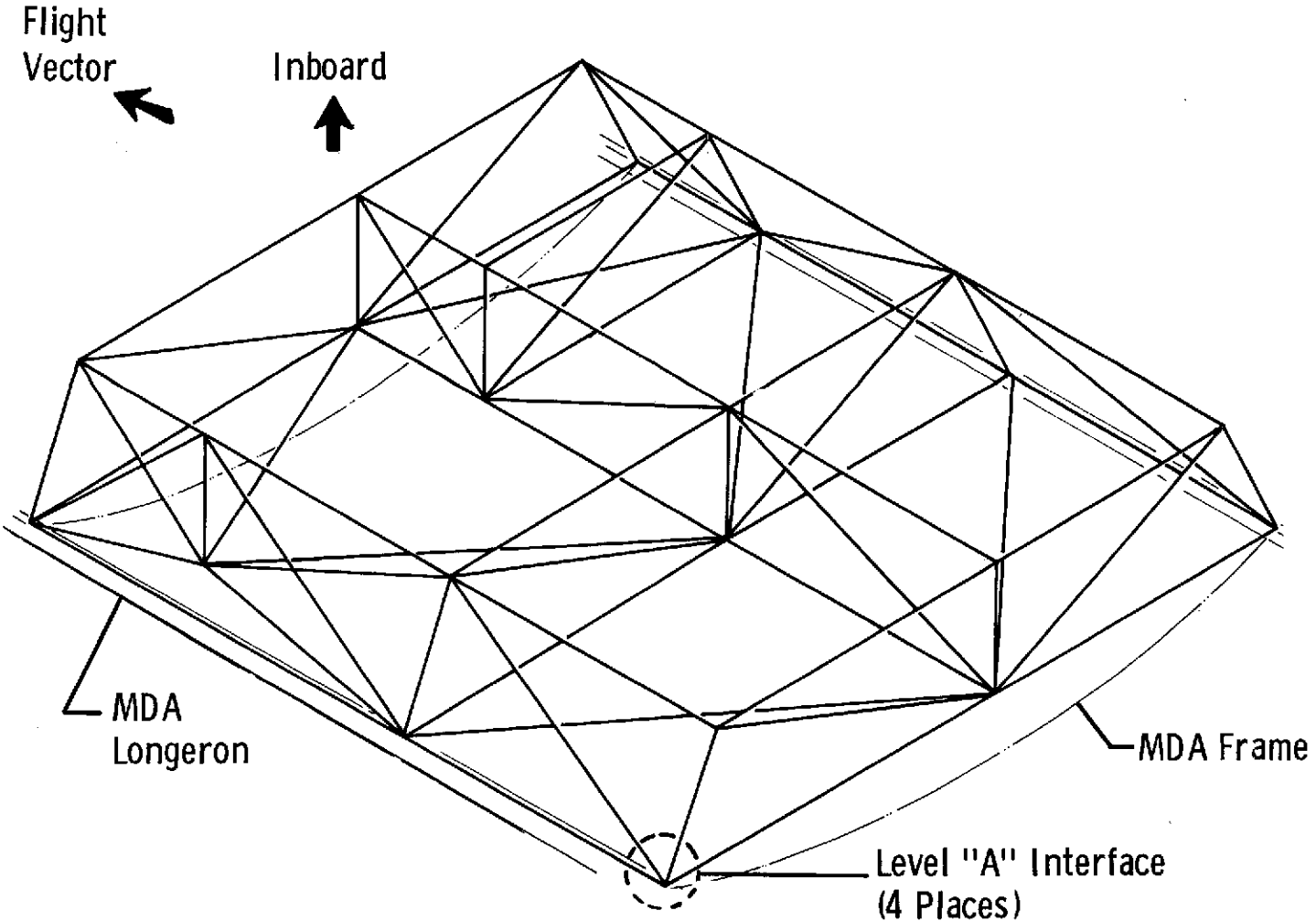

EXPERIMENT SUPPORT EQUIPMENT RACK NO. 2

MARTIN MARIETTA
DENVER DIVISION

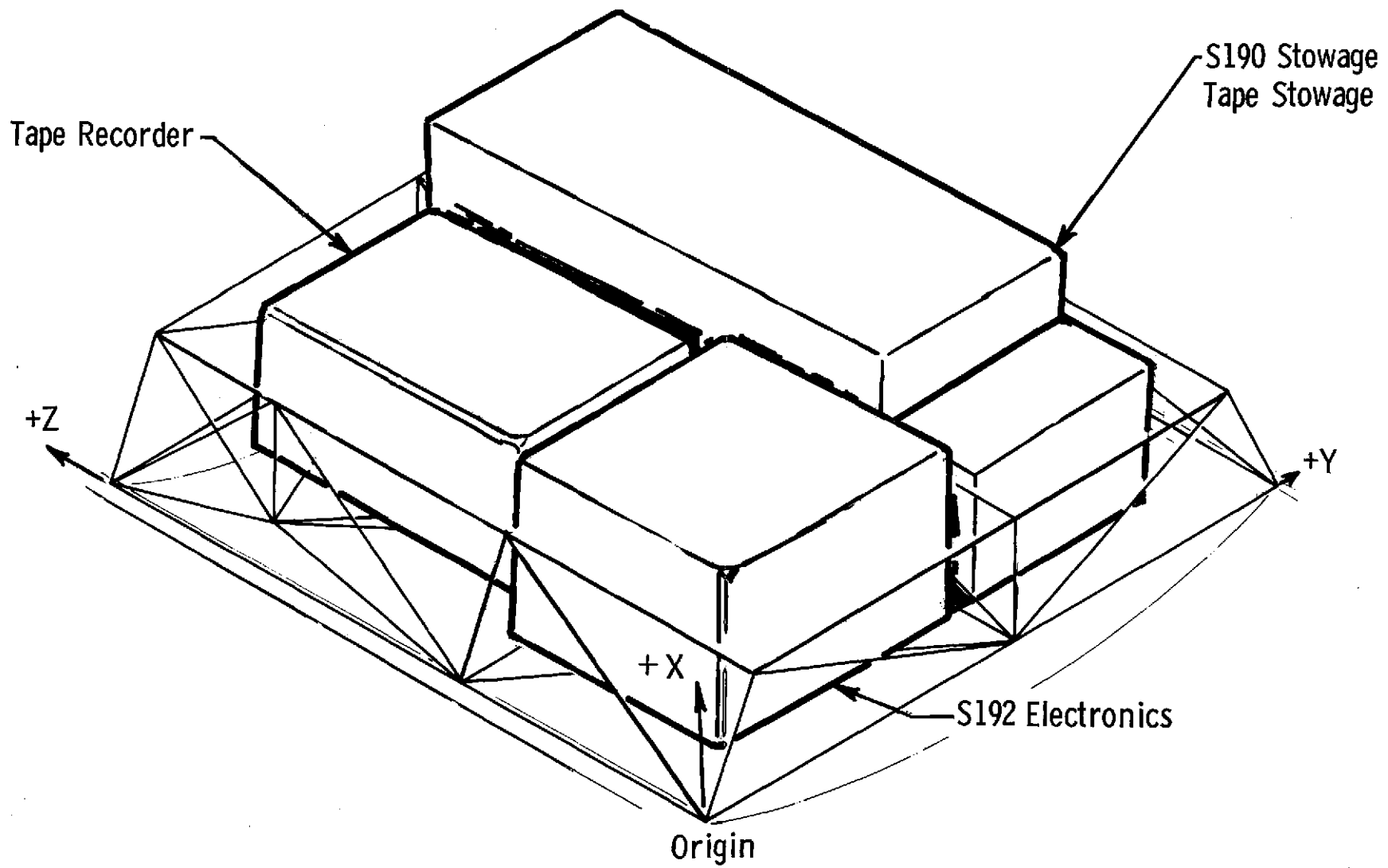

ESE SPARE TAPE RECORDER SUPPORT GEOMETRY

MARTIN MARIETTA
DENVER DIVISION

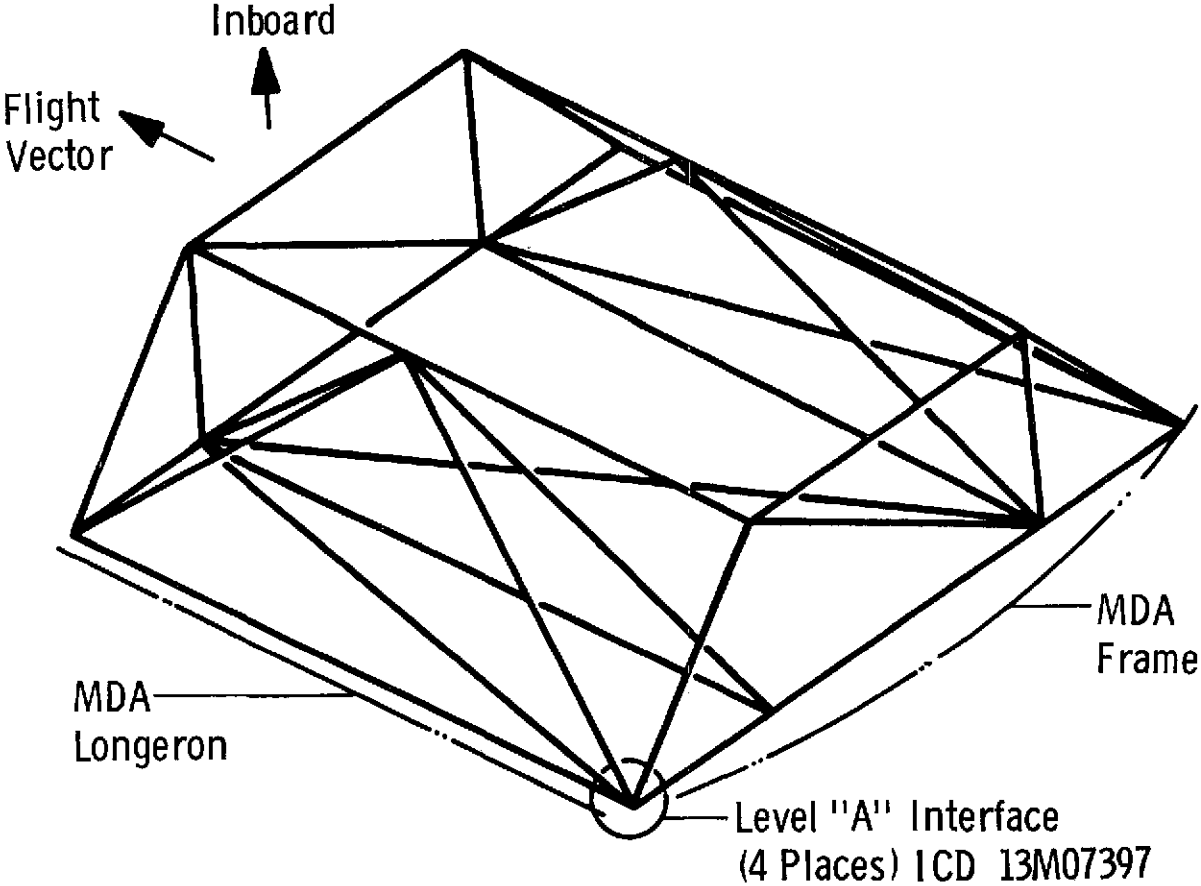

ESE SPARE TAPE RECORDER SUPPORT

MARTIN MARIETTA
DENVER DIVISION

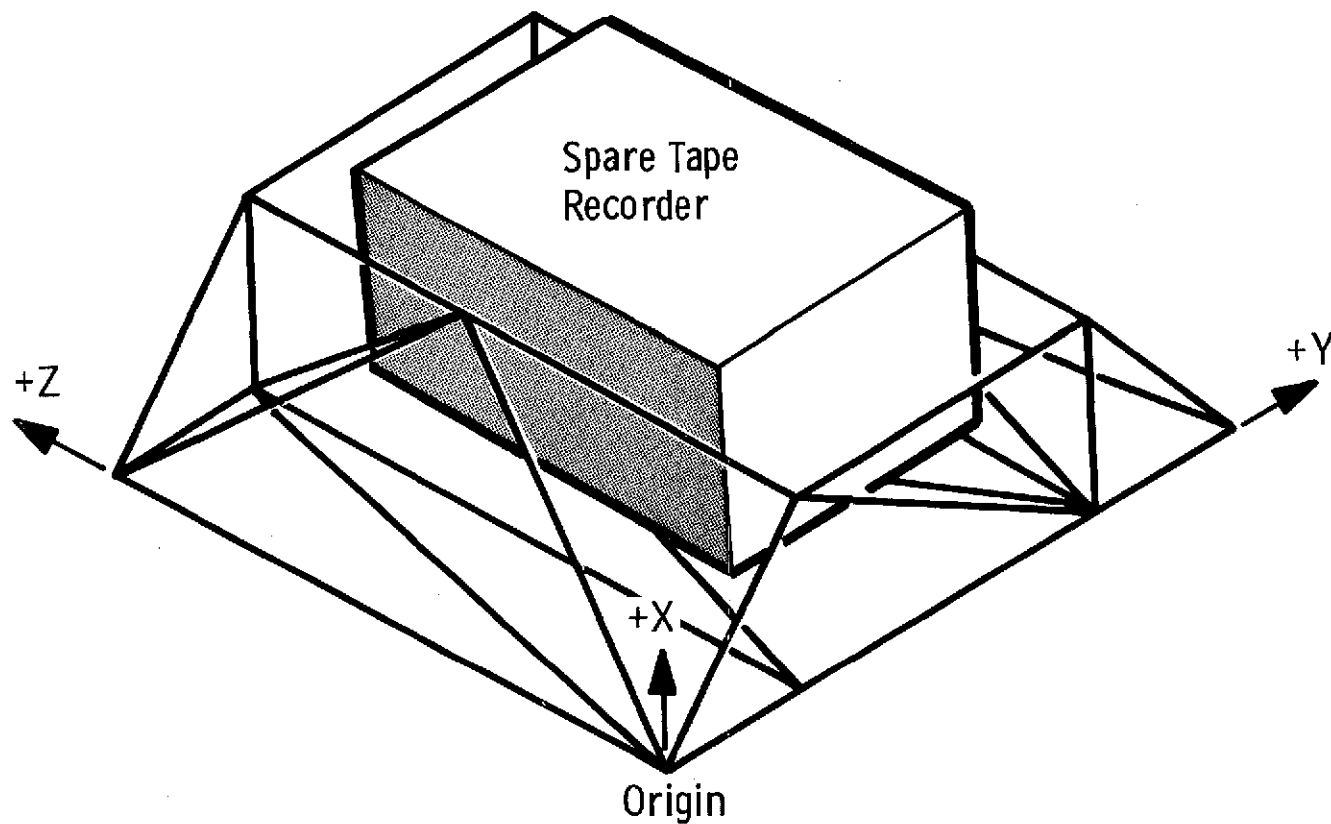

EREP/ESE RACK CABLING DIAGRAM

MARTIN MARIETTA
DENVER DIVISION

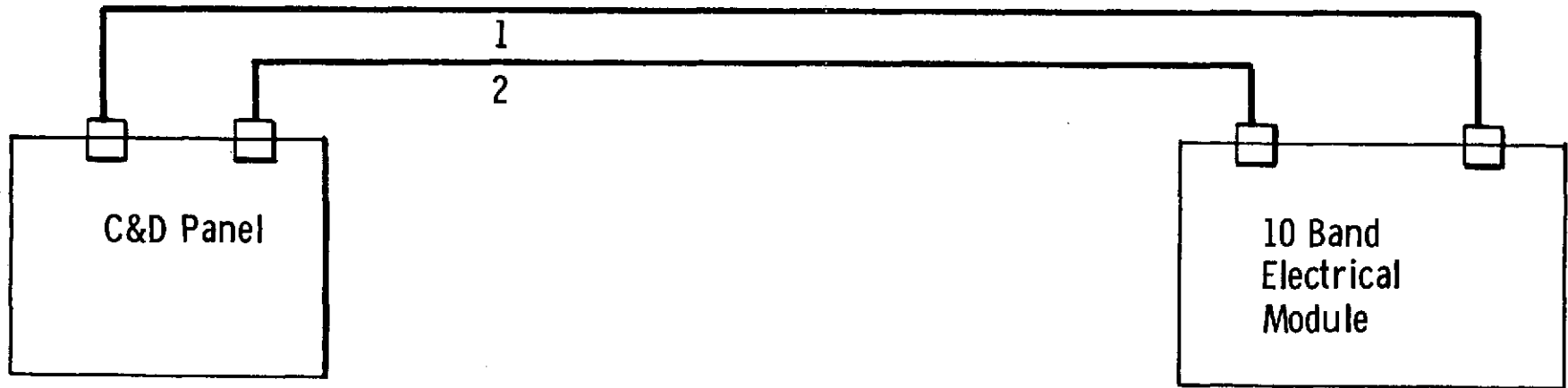

Cable No.

1

Cable Configuration

14 20GA TPS
22 20GA SCS
9 20GA U

Function

Control & Display

2

30 20GA TPS

23 Data Channels & Clock

TYPICAL EREP/ESE CABLE

MARTIN MARIETTA
DENVER DIVISION

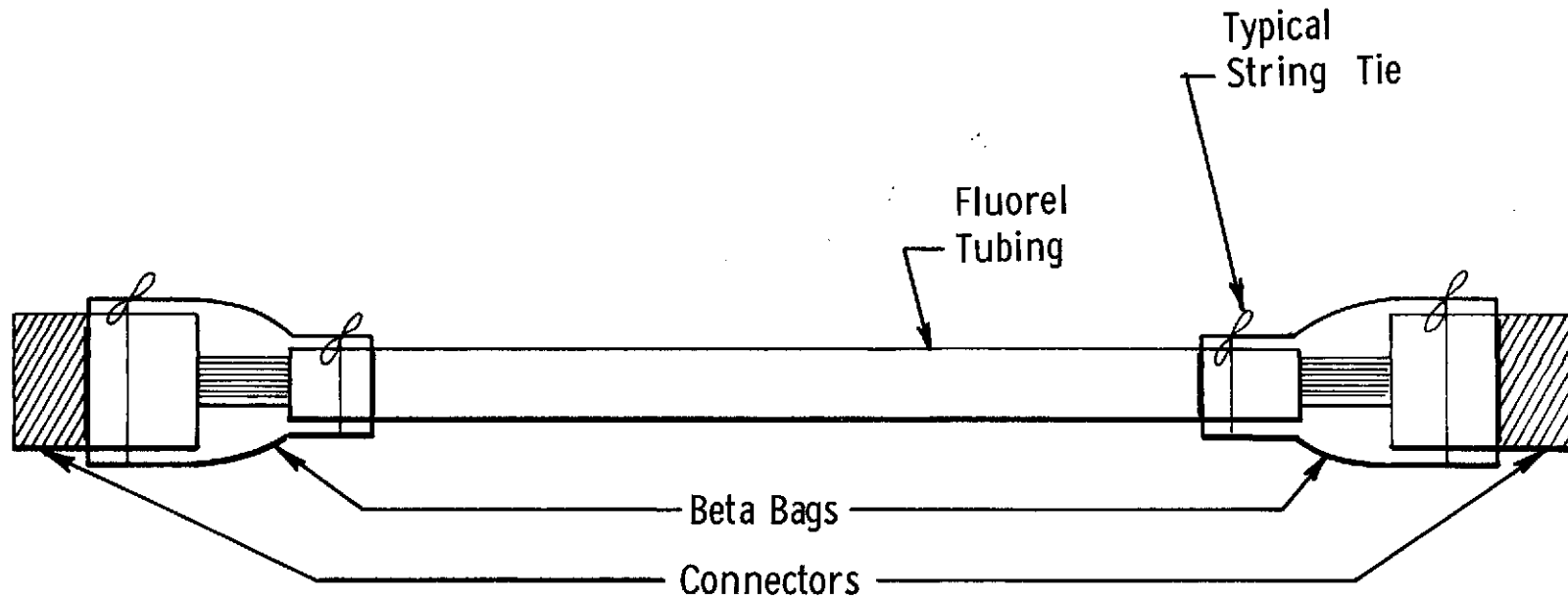

TESTS HAVE BEEN RUN ON THIS CONFIGURATION AT MSFC FOR QUALIFICATION
PER TYPE I MATERIALS OF MSFC-SPEC-101A

SCHEMATIC EREP ELECTRONICS COOLING ASSEMBLY

MARTIN MARIETTA
DENVER DIVISION

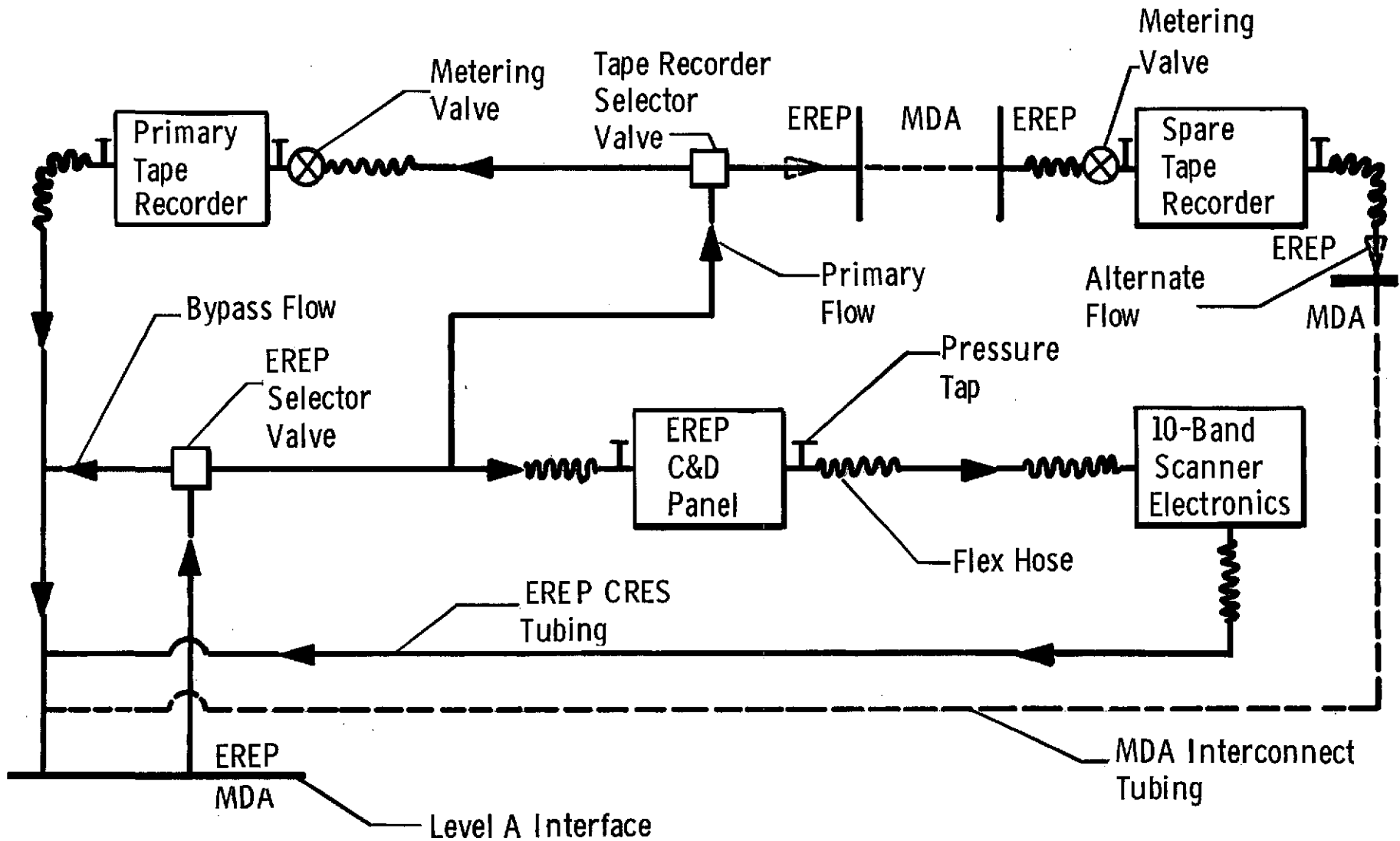

SPECIFICATION WEIGHT STATEMENT FOR EXPERIMENT SUPPORT EQUIPMENT

MARTIN MARIETTA
DENVER DIVISION

ITEM	WEIGHT (lb)
Rack No. 1	60
Rack No. 2	98
Interconnecting Coolant Tube Assembly	15
Interconnecting Cables	25
Two (2) Cables	
Tape Recorder Support	60
* Total MDA Specification Weight	258
Magnetic Tape Handling Container (4)	16
** Total CM Specification Weight	16
*Launch Weight for Skylab 1	
**Launch Weight for Each Skylab 2, 3, and 4	

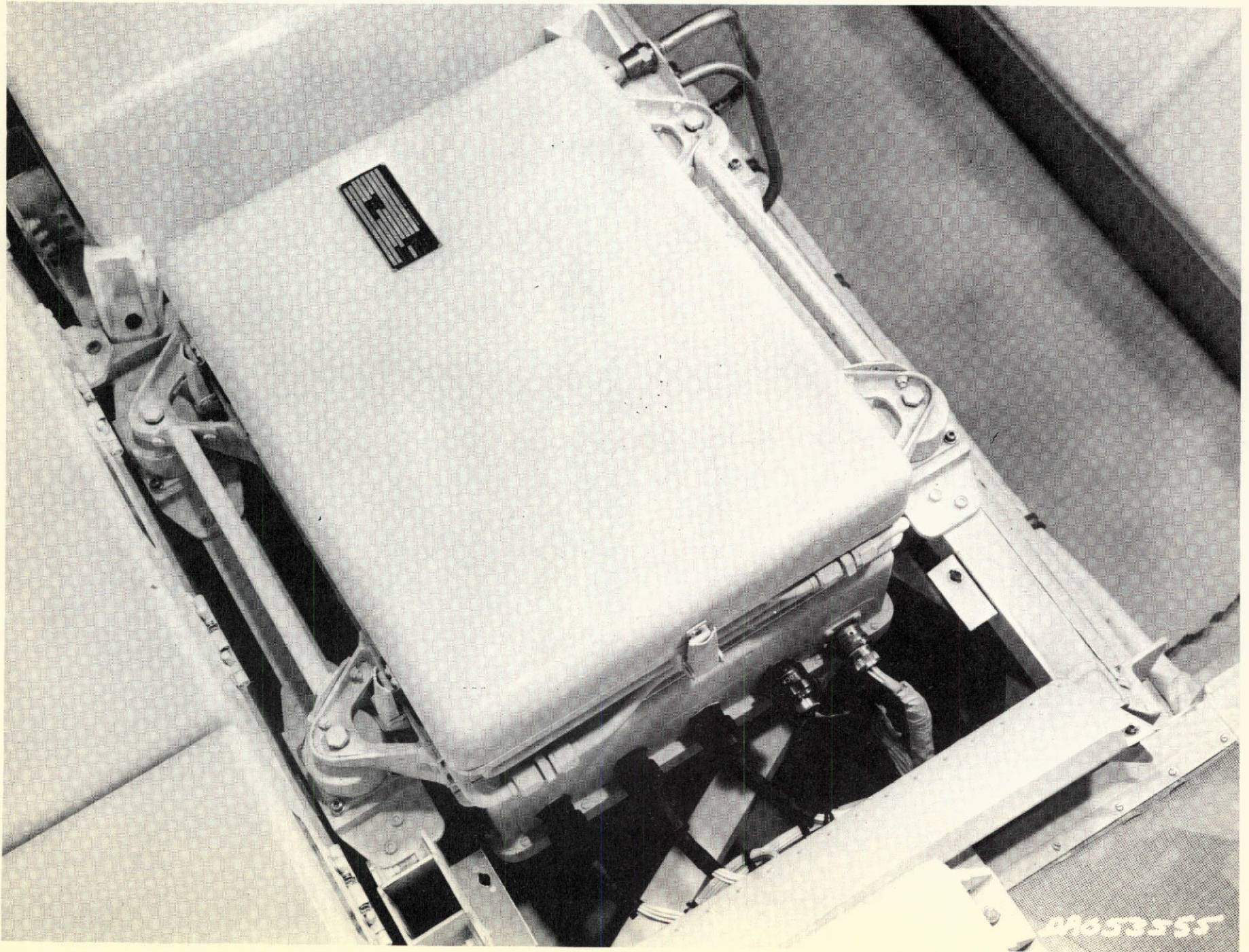

09653555

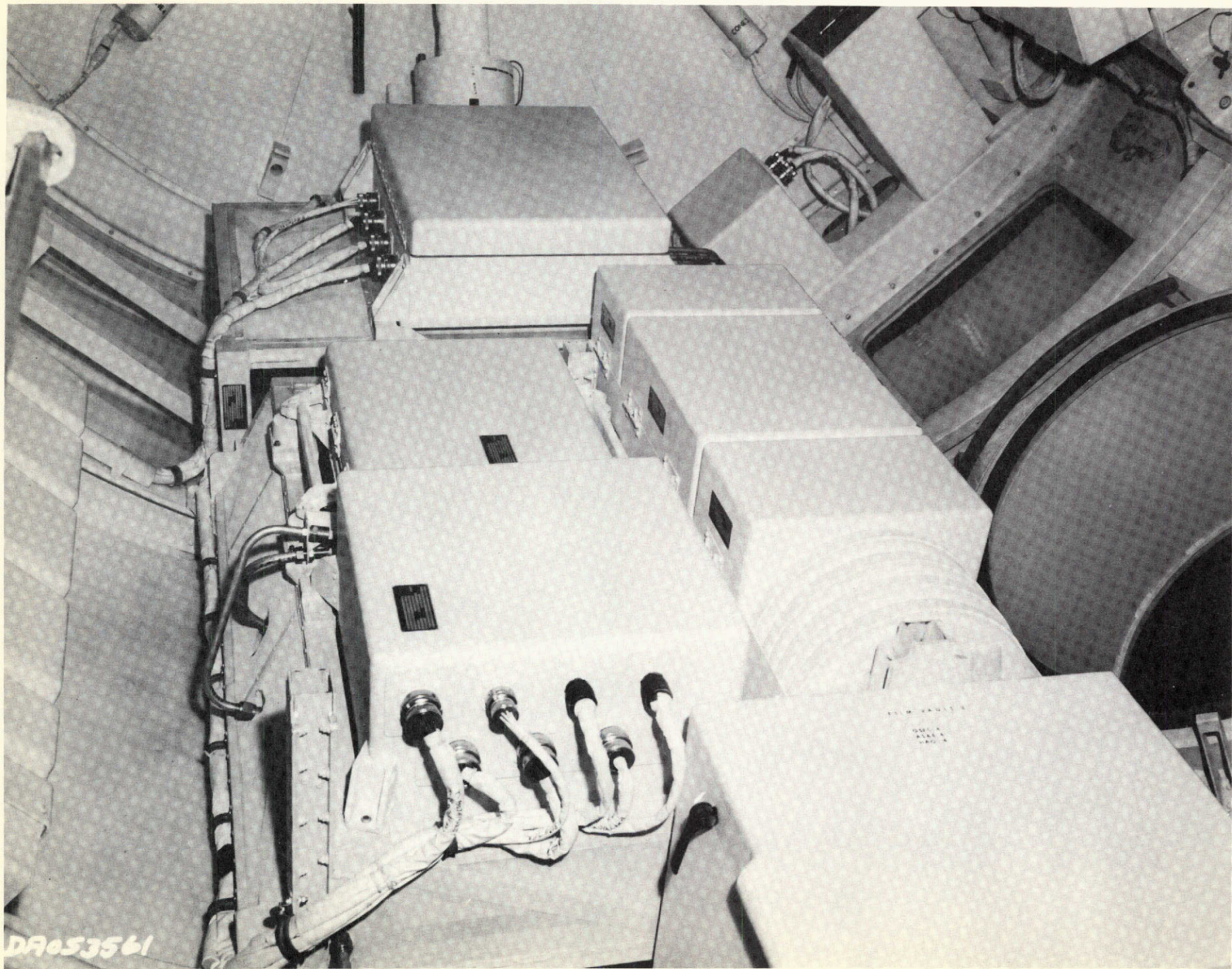

DA053561

EREP-VIEWFINDER/TRACKING SYSTEM

The V/TS will serve the primary purpose of acquiring time correlated spectrographic and photographic data, within a selected target as small as one square mile, from a nominal orbital altitude of 235 nautical miles. The V/TS shall acquire and track the target by use of a telescope, hand controller and articulating mirror. The energy collected by the articulating mirror is reflected into the infrared spectrometer via the Cassegrainian optics, and into the telescope for astronaut viewing. The image as viewed by the crewman is optically relayed to the GFE support camera. The IR Spectrometer field of view (FOV) is 0.235 n mile square at ground nadir. The V/TS shall be capable of operating independently of the IR Spectrometer.

The V/TS consists of the following components installed as indicated and displayed in Figure

<u>Internal MDA</u>	<u>External MDA</u>
Telescope	IR Spectrometer Case Assembly
Camera (GFE)	Gimballed Mirror Assembly
Control Panel and Electronics Assembly	Cassegrain Optics and Pickoff Mirror
Hand Controller (GFE)	Infrared Spectrometer (GFE)
	Black Body Reference Source
	Alignment Collimator

OPERATING DESCRIPTION

The astronaut, in orbit, will remove both the GFE support camera and film magazine from their storage containers and install the camera on the mounting rail provided on the V/TS. The film magazine will then be installed on the camera. V/TS power is then activated and a checkout of the system will be accomplished by making necessary camera adjustments and reticle alignment using the collimating light source of the IR Spectrometer Case Assembly. All switches and controls on the control panel are located in such a manner that the astronaut is not required to remove his eyes from the telescope eyepiece for V/TS operation. The Spectrometer calibration switch is then manually actuated, which starts an automatic IR Spectrometer calibration cycle.

Prior to arrival at the target area, the astronaut will align the telescope and IR Spectrometer LOS using a collimated light source, the gimballed mirror, the Cassegrain optics and pickoff mirror. He will then activate the switch that electrically opens the IR Case Door, and calibrates the IR Spectrometer using the automatic calibration sequence. He will then off-set the line of sight by presetting the along and cross track gimbal mirror angles as displayed in the telescope FOV.

As the target is approached, a visual search will be made for initial points (IPs), then the astronaut will "navigate" his way to the target by progressively identifying smaller IPs until the target area appears in the FOV. Controls, at this point, will be in "High Gain". When the target has moved near the reticle aim point, the crewman will make adjustments to center the reticle in the target area and activate the Image Motion Compensation (IMC) Control. The IMC removes most of the target motion as seen in the telescope. The astronaut will continue to track the target by keeping the reticle centered on the target area and he will begin "zooming in" on the target. When fully zoomed with the target centered, the camera on, and between 10° forward or aft of local vertical, the crewman will depress the switch for data acquisition. Time (GMT), gimbal angles, and photographic identification of the target are recorded by the camera. Spectrometer data is recorded by the EREP tape recorder.

The astronaut will return only the film magazine to storage during extensive between-operations periods. Upon completion of the mission, the film will be moved to the Command Module film vault for return to earth.

SYSTEM DESCRIPTION

The V/TS shall consist of the following subsystems:

- Gimballed Mirror Assembly - The articulating mirror shall direct the LOS at the V/TS and IR Spectrometer.
- Telescope Assembly - The telescope assembly shall provide the astronaut with a means of viewing the selected ground targets with adjustments of focus, magnification, and reticle position. Numeric displays of essential information shall be included in the telescope FOV. The telescope FOV shall be optically relayed to the camera.

- Cassegrain Optics and Pickoff Mirror Assembly - The Cassegrain optics collect the IR and visual radiation from the ground target and focus it on the objective point of the IR Spectrometer for spectral data acquisition. The pick-off mirror directs radiation from the gimballed mirror through the MDA window into the telescope.
- IR Spectrometer Case Assembly - The IR Spectrometer Case is an enclosure external to the MDA, which provides thermal and meteoroid shielding for the internally mounted components. The internal components are the gimballed mirror assembly, pickoff mirror, Cassegrain assembly, IR Spectrometer, black body reference, and alignment collimator. The case assembly is provided with an aperture through which viewing of ground targets is accomplished. A motor driven door covers the aperture when the V/TS is not in use.
- Control Panel and Electronics Assembly - The Electronics Assembly conditions and distributes power to the V/TS and provides servo loop controls and displays to the system. The Control Panel provides a means of mounting and locating the various switches, controls, and displays for V/TS operations.
- Hand Controller - The GFE hand controller is mounted on the control panel and provides manual control in pointing the V/TS LOS in the FOV.
- Camera - A GFE camera is optically and electronically interfaced with the V/TS for photographing the target.

VIEWFINDER TRACKING SYSTEM

MARTIN MARIETTA
DENVER DIVISION

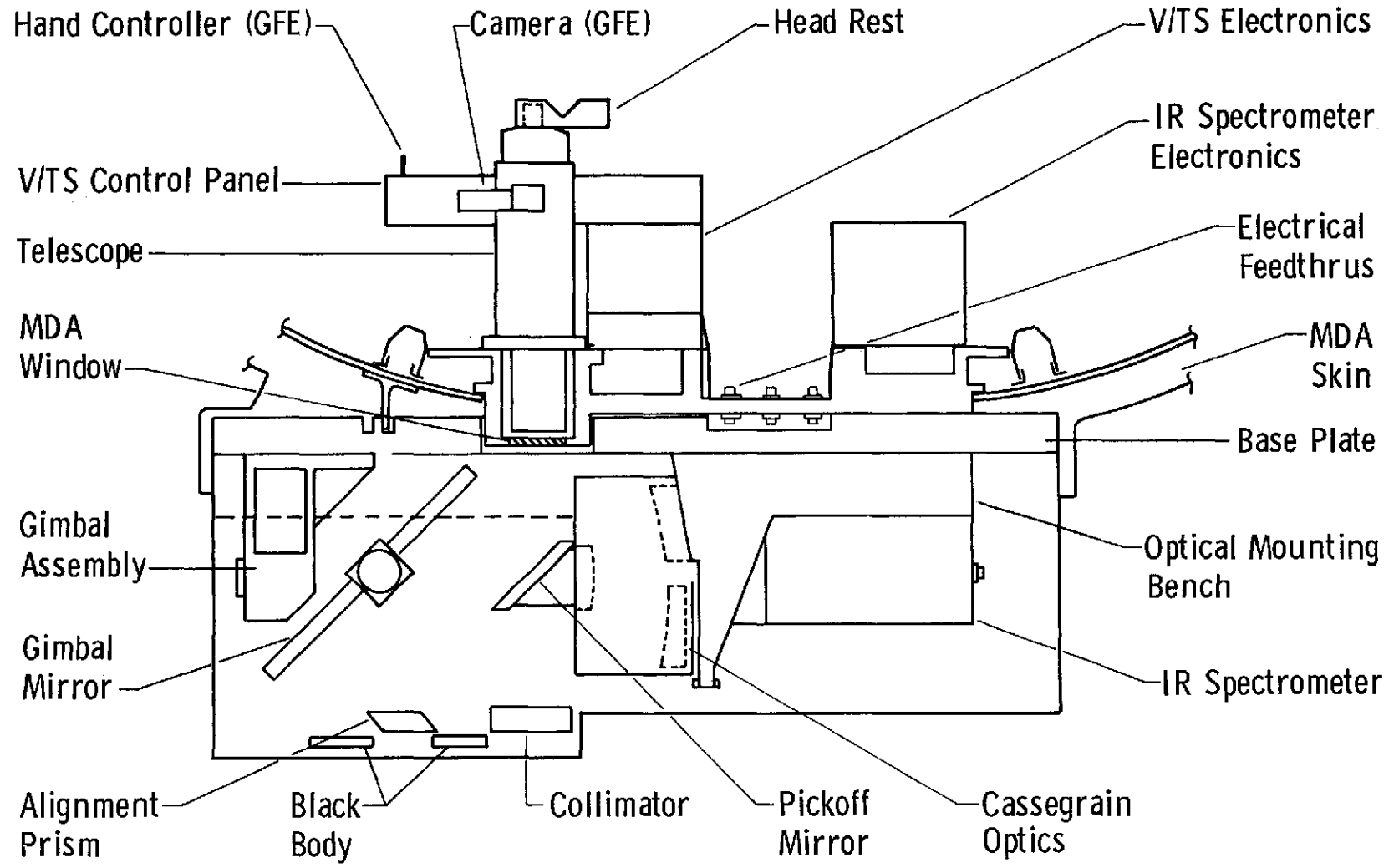

V/TS BLOCK DIAGRAM - ELECTRICAL

MARTIN MARIETTA
DENVER DIVISION

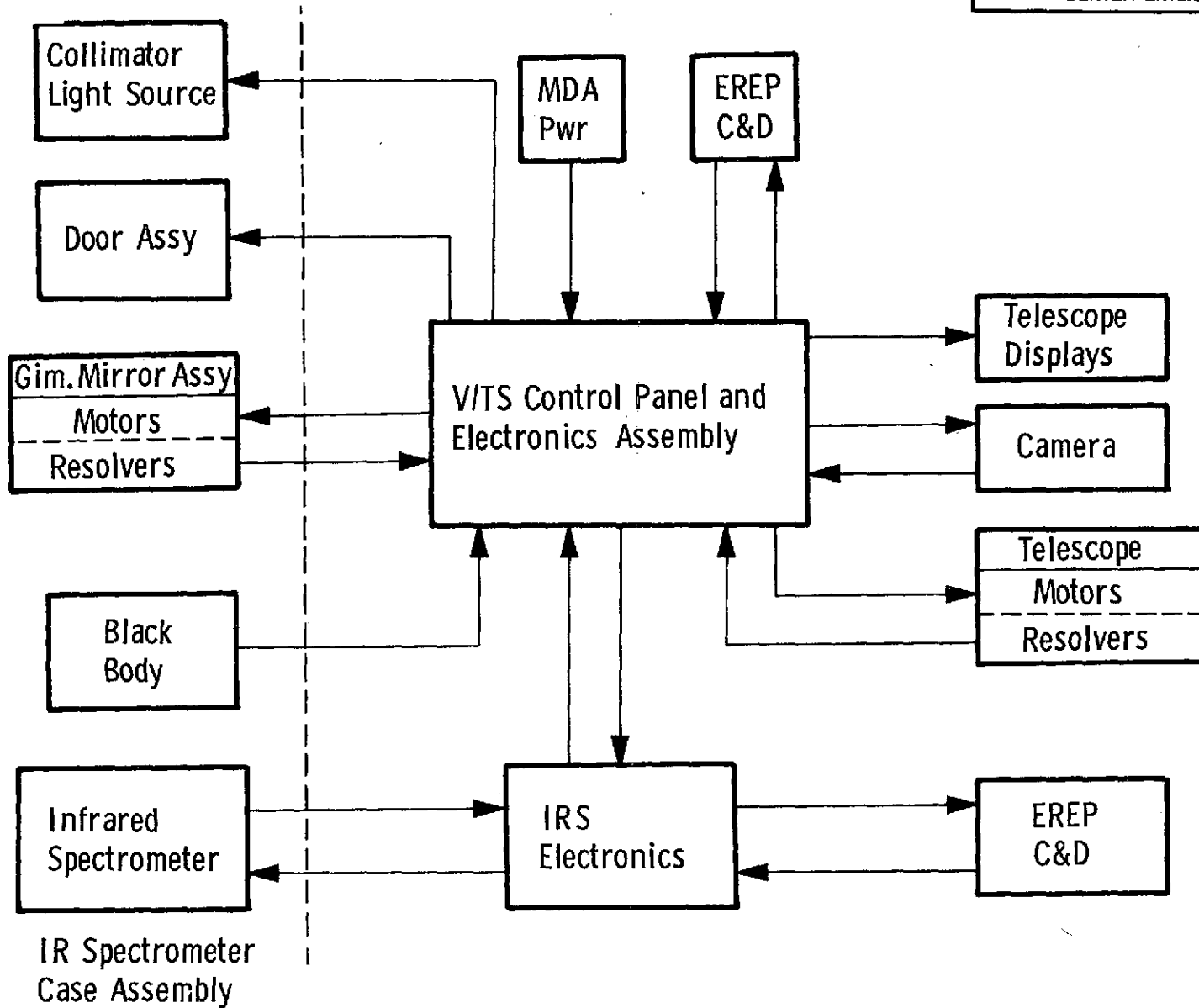

IR SPECTROMETER CASE ASSEMBLY HOUSING

MARTIN MARIETTA
DENVER DIVISION

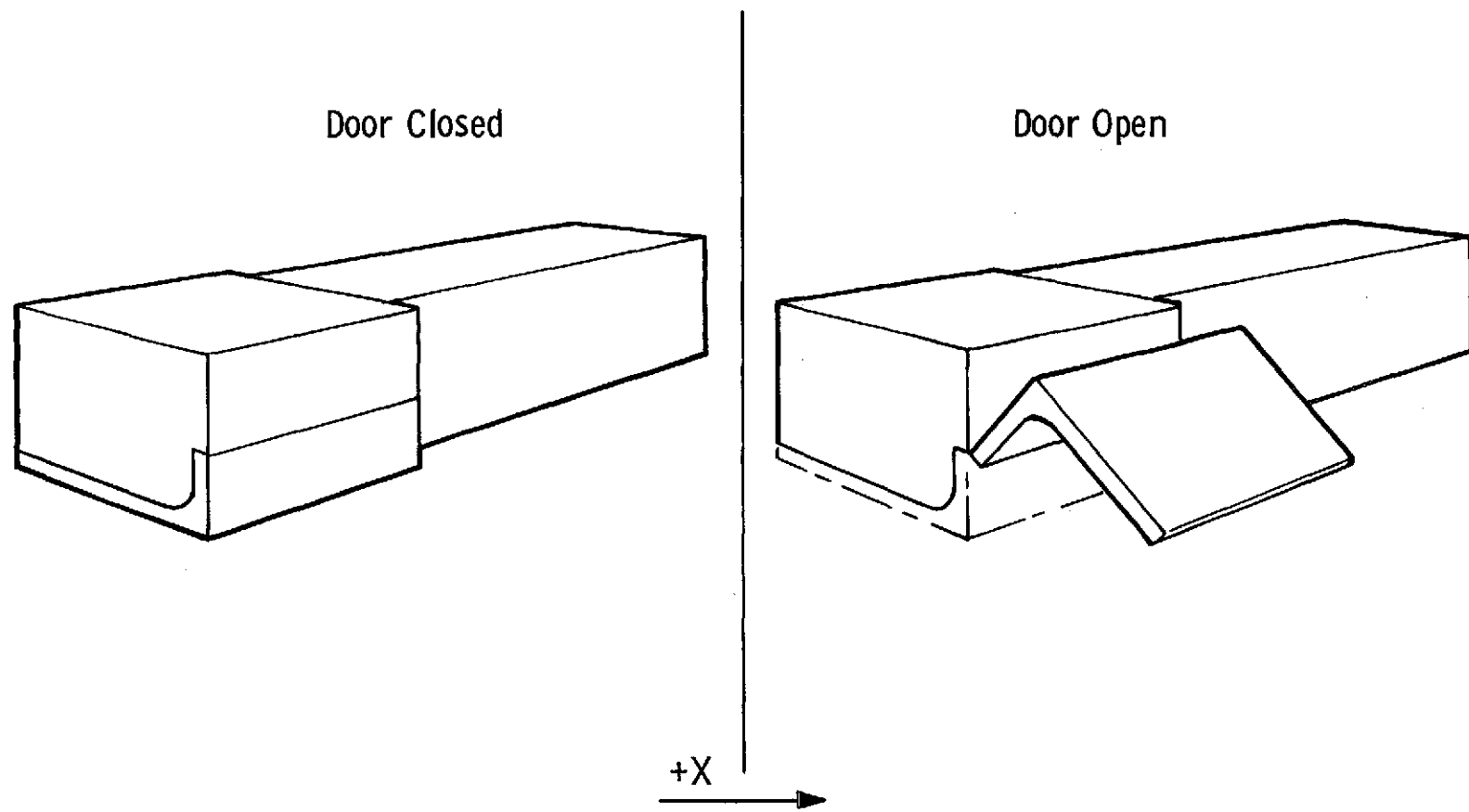

GIMBAL MIRROR ASSY (PICTORIAL)

MARTIN MARIETTA
DENVER DIVISION

Along Track
Rotational
Axis

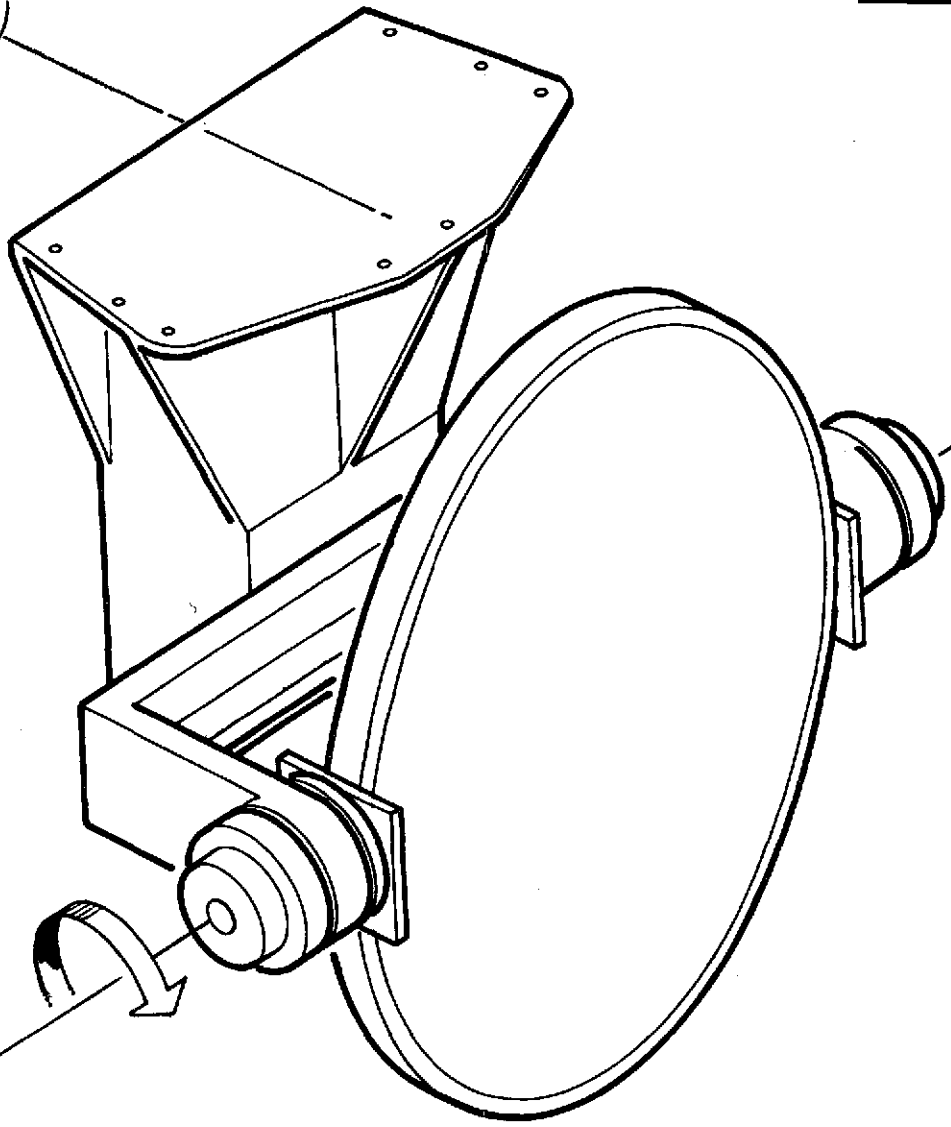

Cross Track
Rotational
Axis



IR SPECTROMETER CASE ASSEMBLY WITH HOUSING REMOVED

MARTIN MARIETTA
DENVER DIVISION

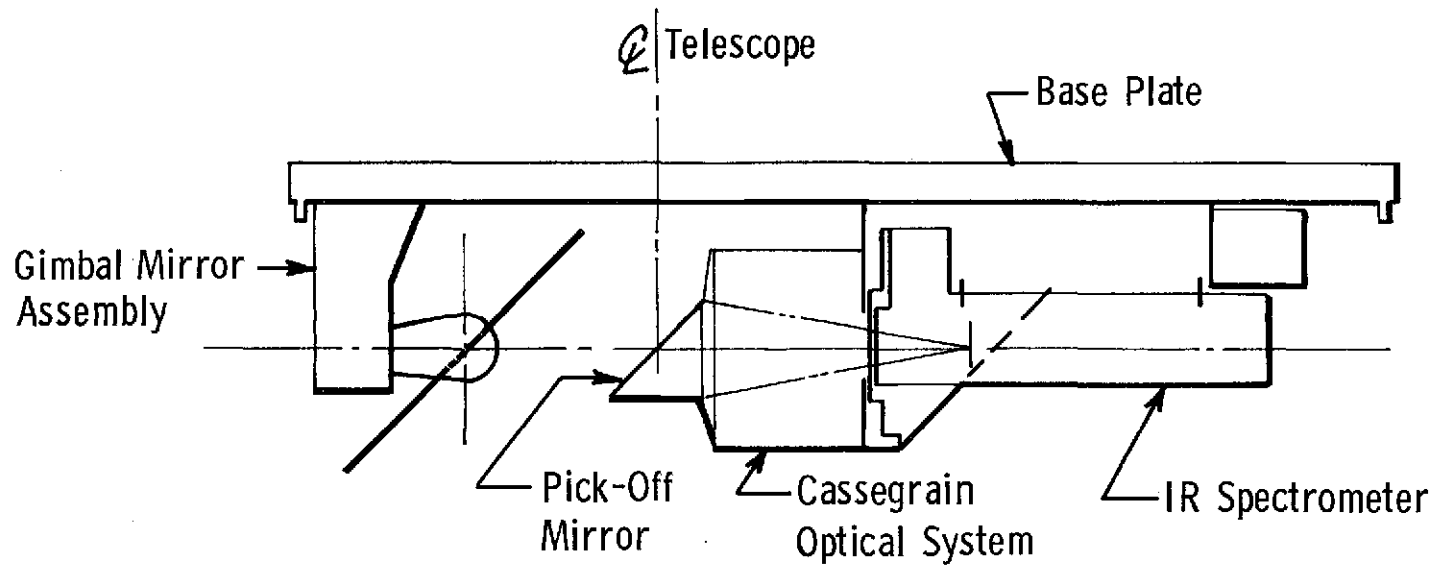

TELESCOPE/SPECTROMETER ALIGNMENT METHOD

MARTIN MARIETTA
DENVER DIVISION

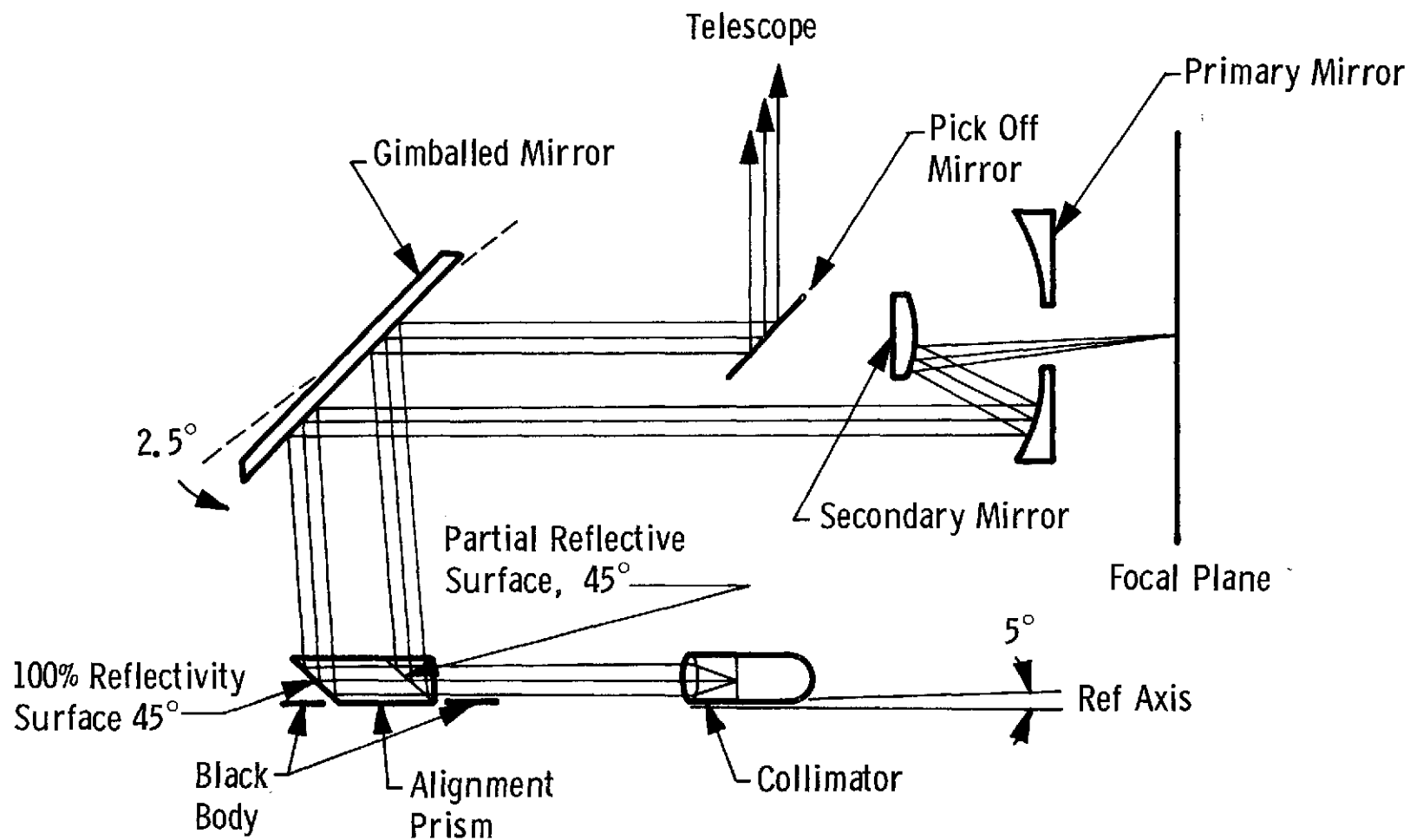

VIEWFINDER TRACKING SYSTEM TELESCOPE OPTICS

MARTIN MARIETTA
DENVER DIVISION

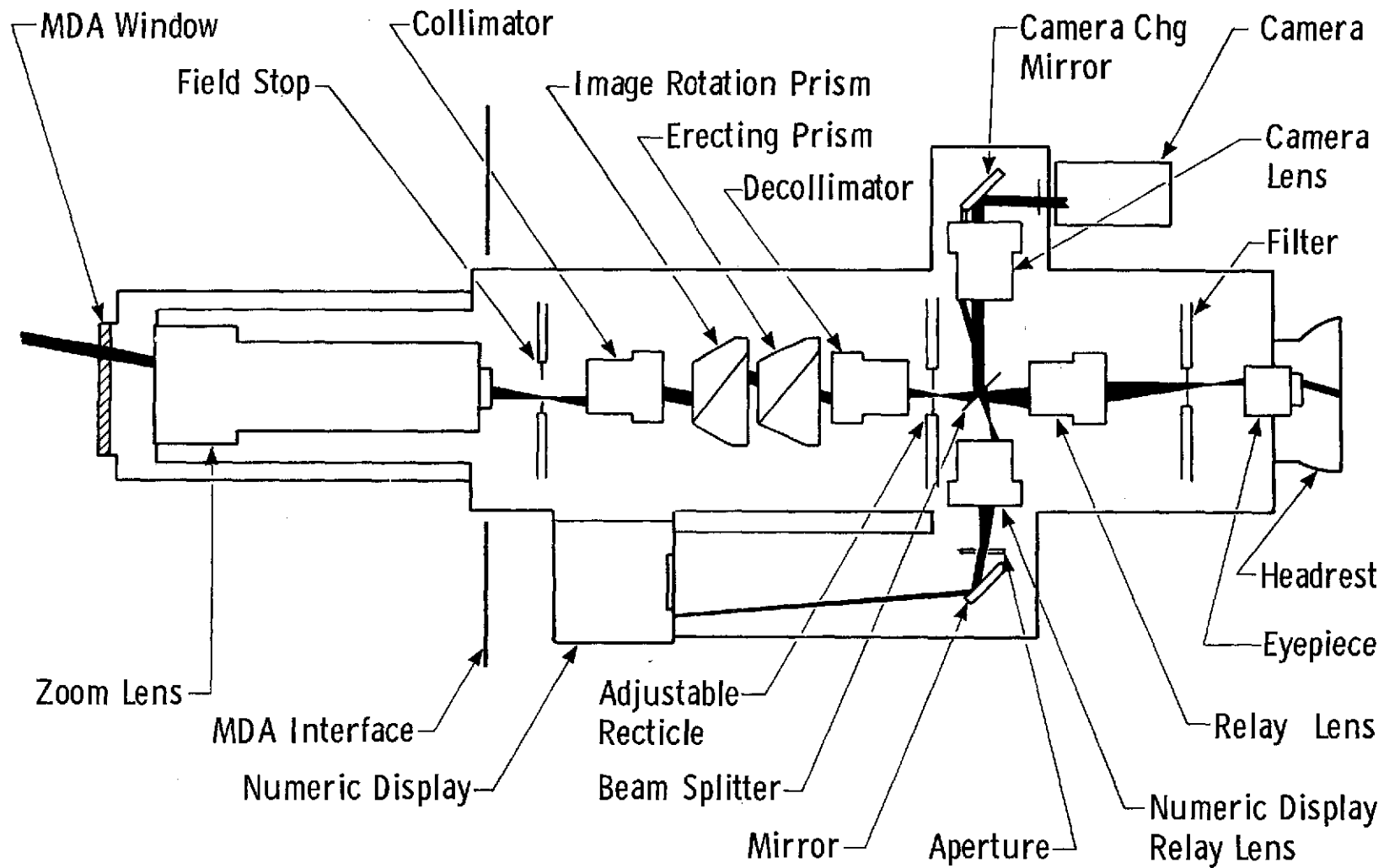

VTS CONTROL & DISPLAY PANEL

MARTIN MARIETTA
DENVER DIVISION

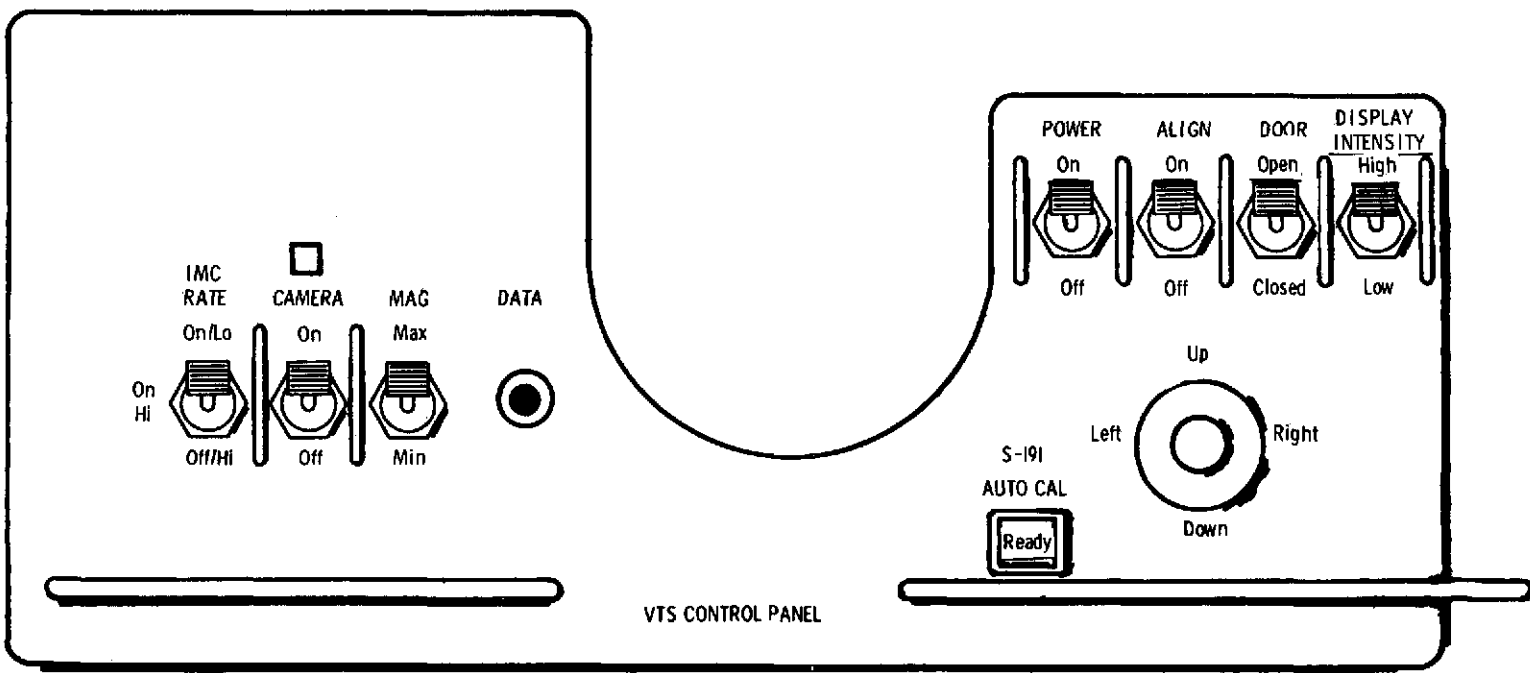

VTS TELESCOPE FIELD OF VIEW DISPLAYS

MARTIN MARIETTA
DENVER DIVISION

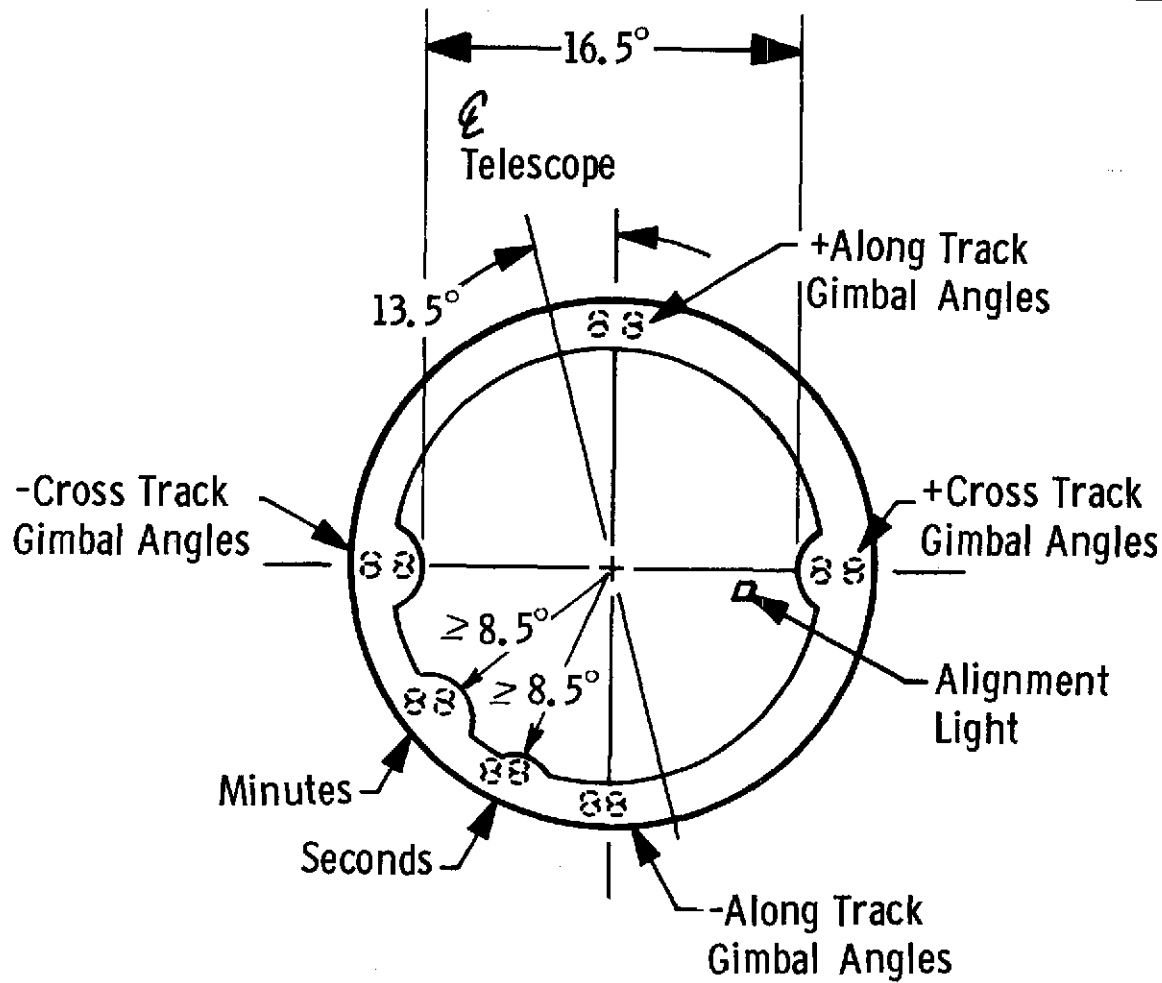

Note: Angular Dimensions Shown
Apply at Minimum Magnification

S190 SUPPLEMENTAL HARDWARE



	<u>FLIGHT</u>	<u>BACKUP</u>
• MOUNT SUPPORT ASSEMBLY	1	1*
• CAMERA FRONT SHIELD	1	1*
• CAMERA REAR SHIELD	1	1*
• FILTER RETURN CONTAINER	18	3
• EQUIPMENT CONTAINER	1	1

*QUALIFICATION UNIT REFURBISHED

S190 CAMERA SUPPORT

MARTIN MARIETTA
DENVER DIVISION

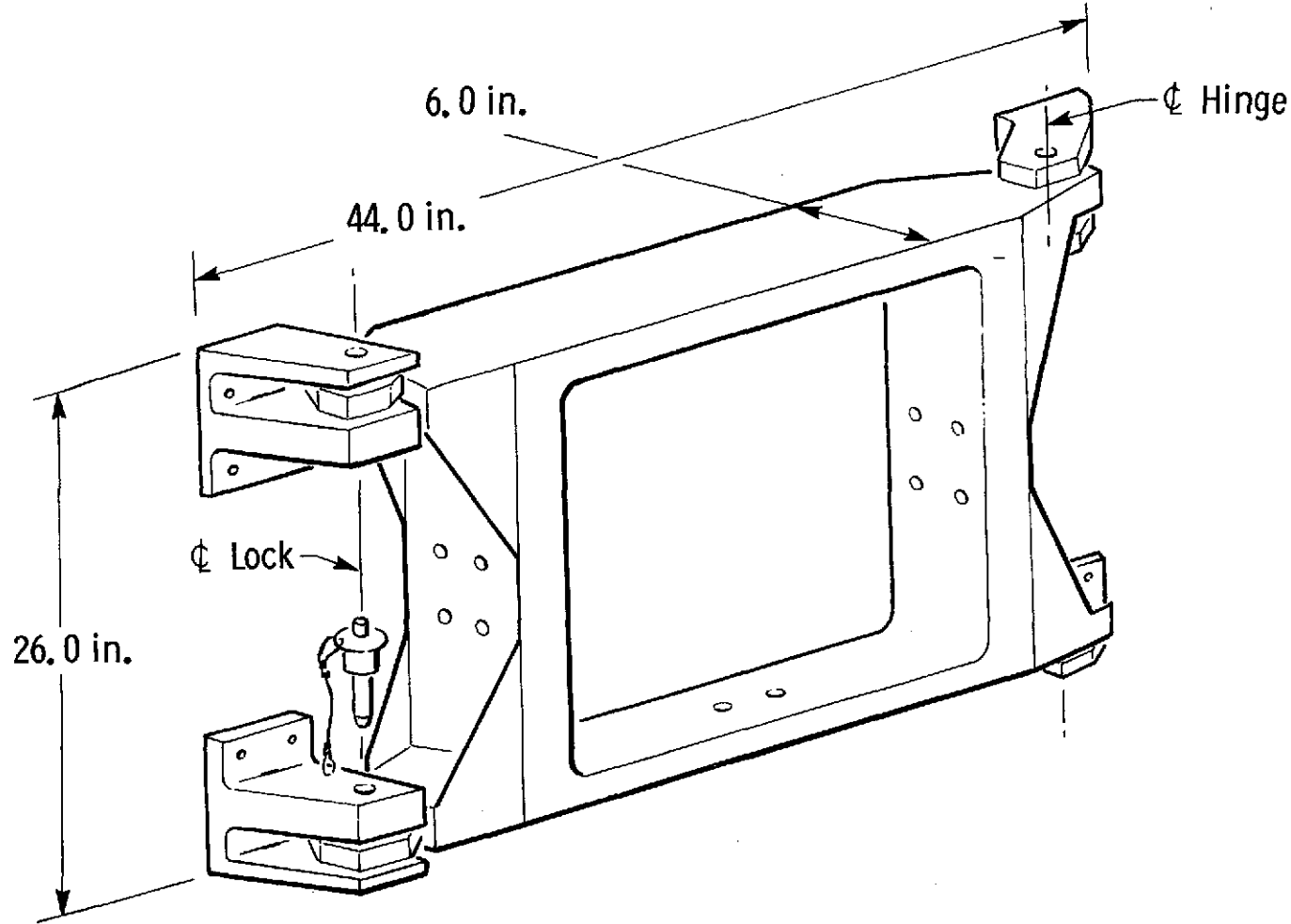

S190 CAMERA FRONT SHIELD

MARTIN MARIETTA
DENVER DIVISION

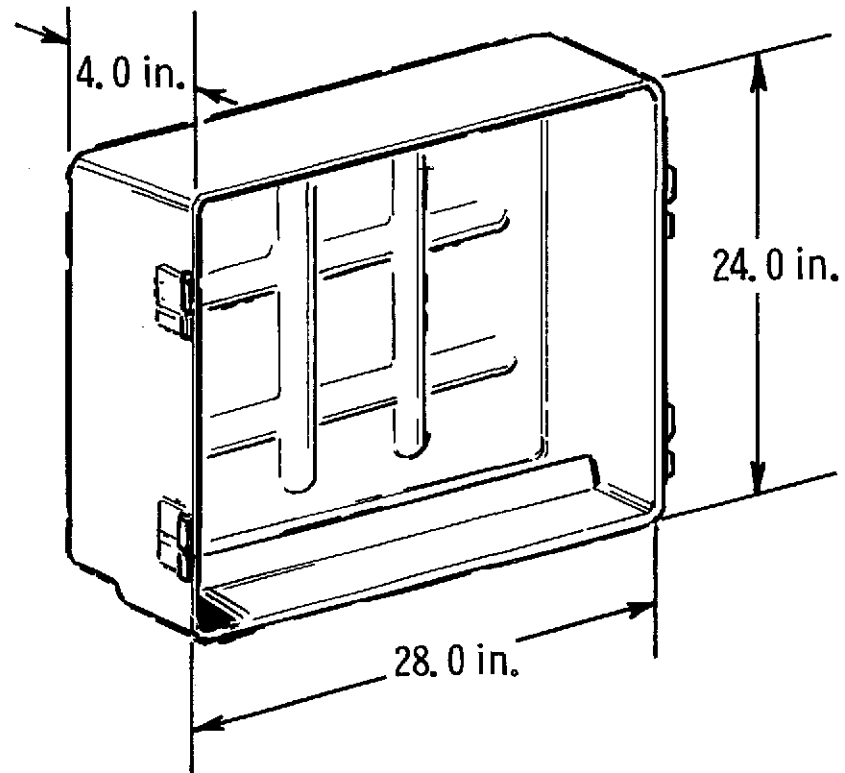

S190 CAMERA REAR SHIELD

MARTIN MARIETTA
DENVER DIVISION

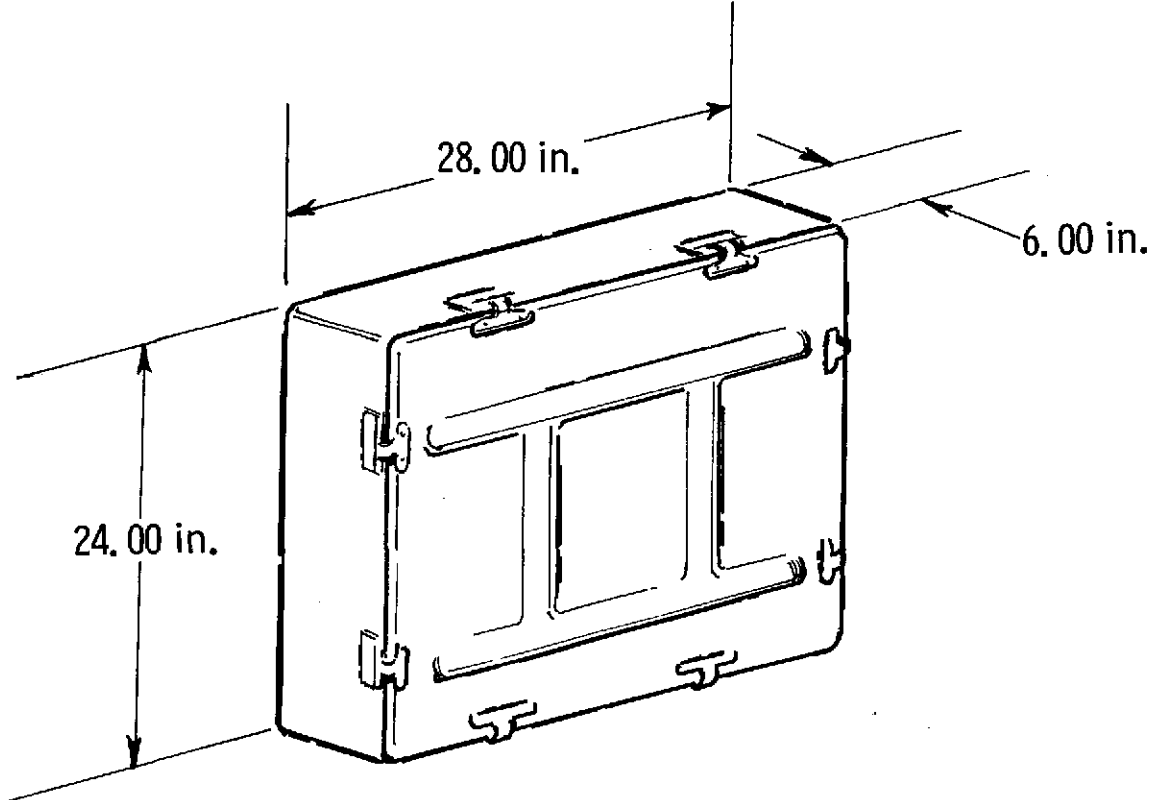

S 190 *MULTISPECTRAL PHOTOGRAPHIC FACILITY*

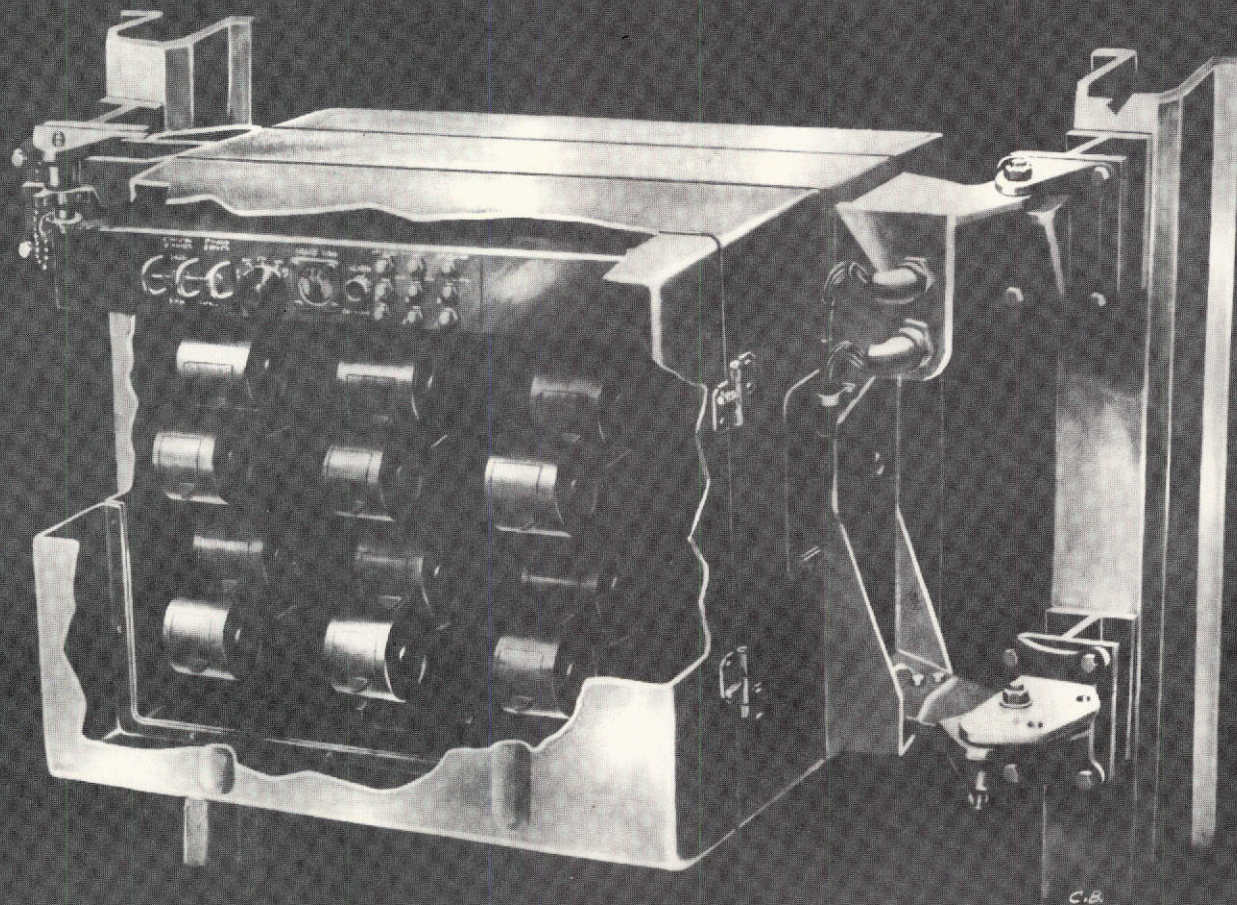

S190 FILTER CONTAINER

MARTIN MARIETTA
DENVER DIVISION

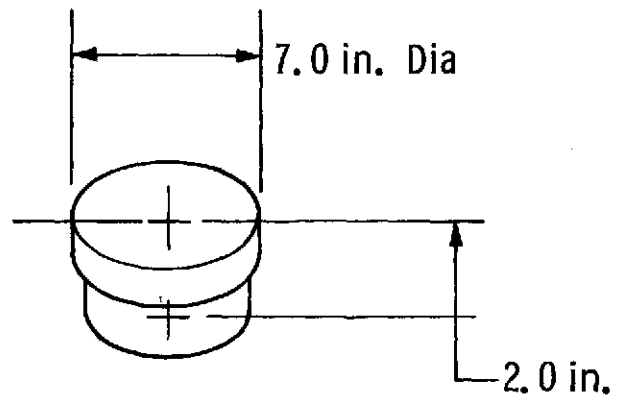

S190 EQUIPMENT CONTAINER

MARTIN MARIETTA
DENVER DIVISION

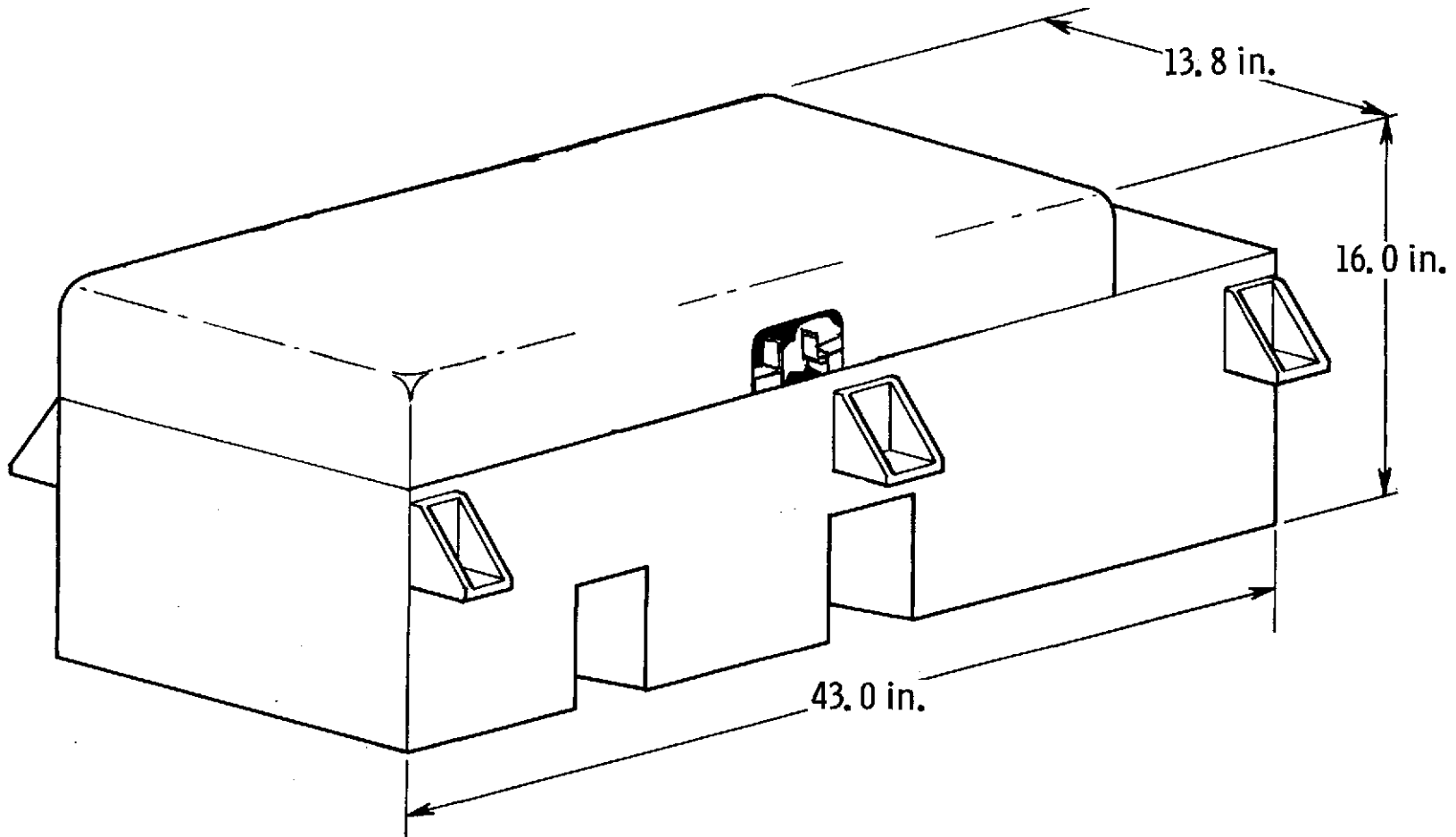

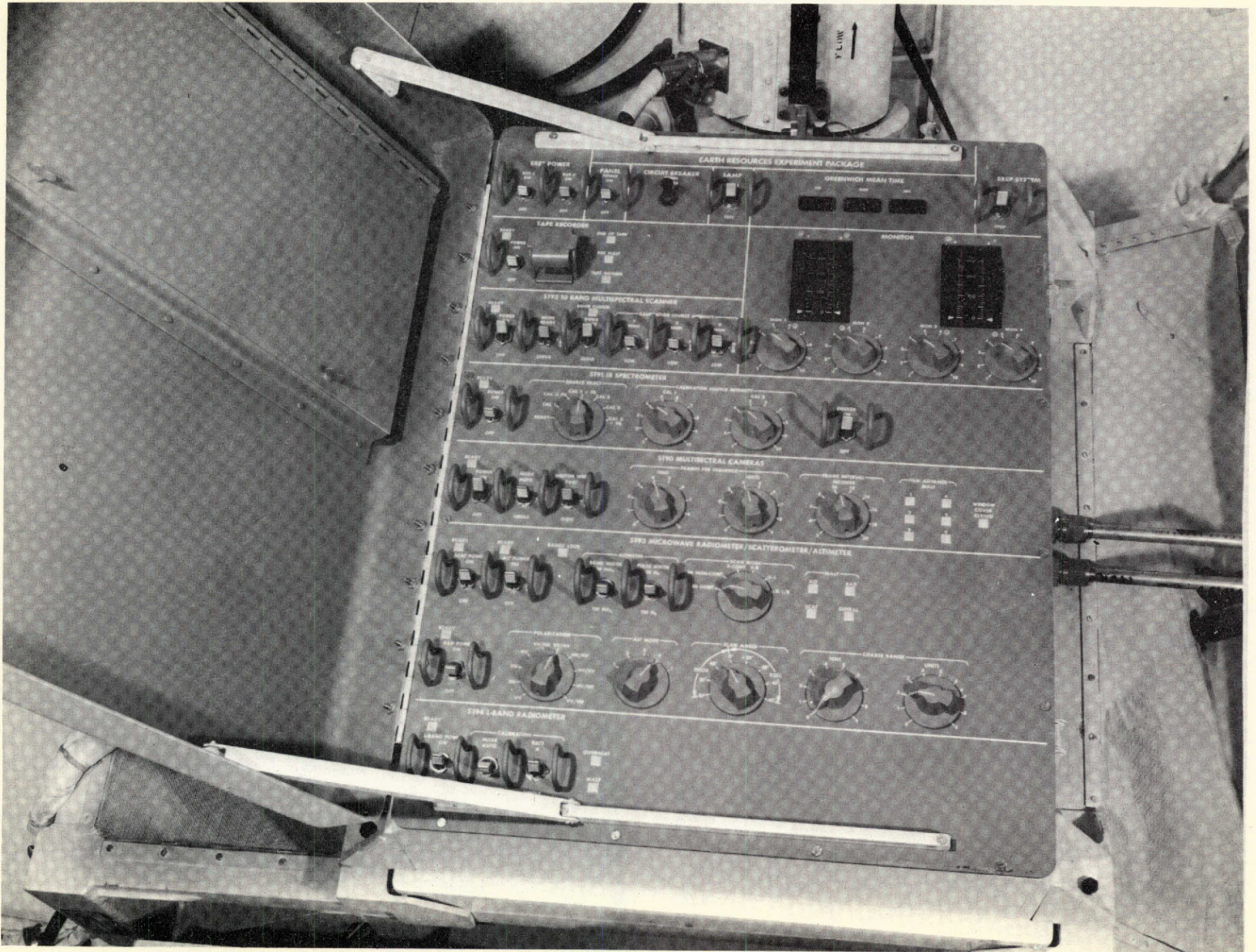

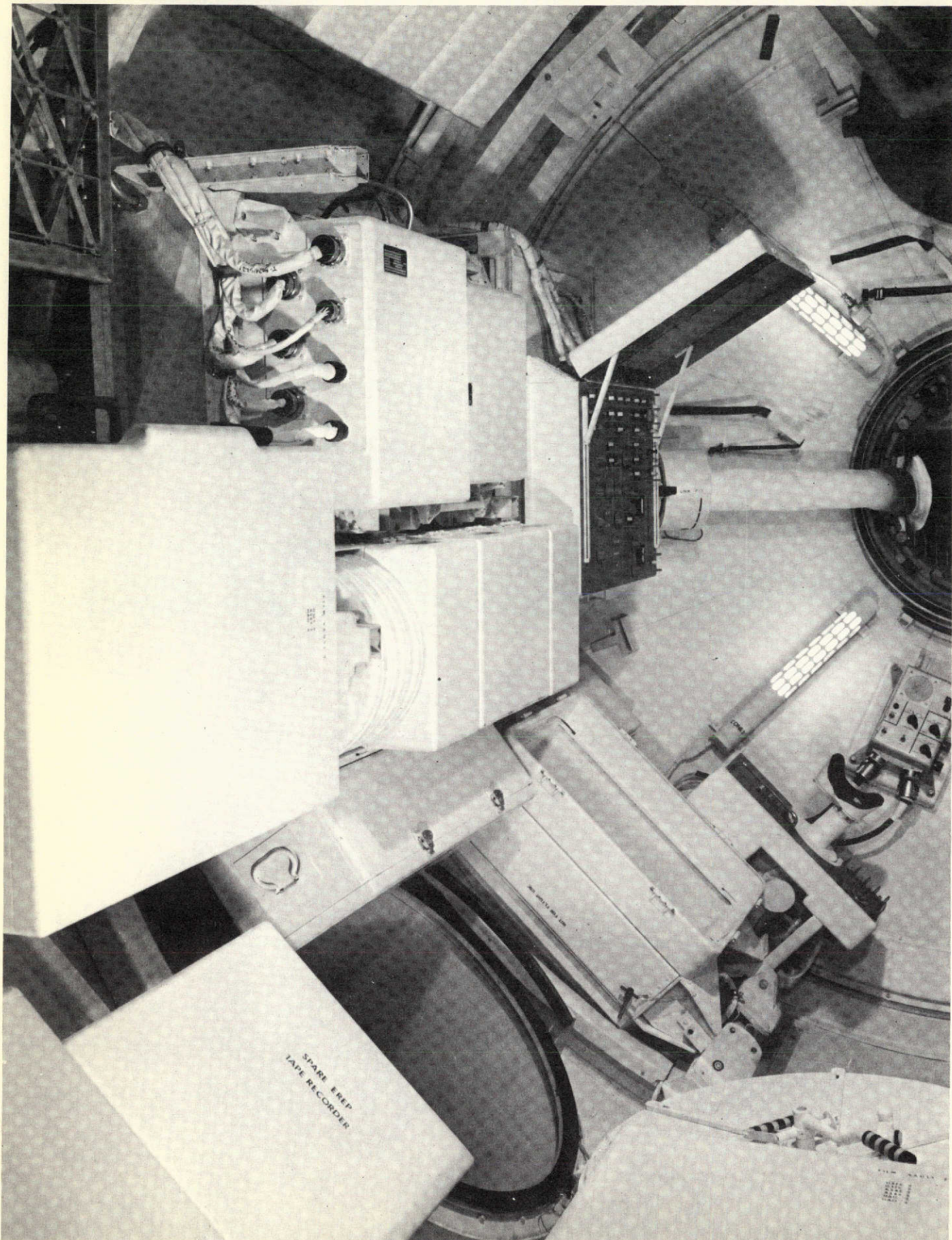

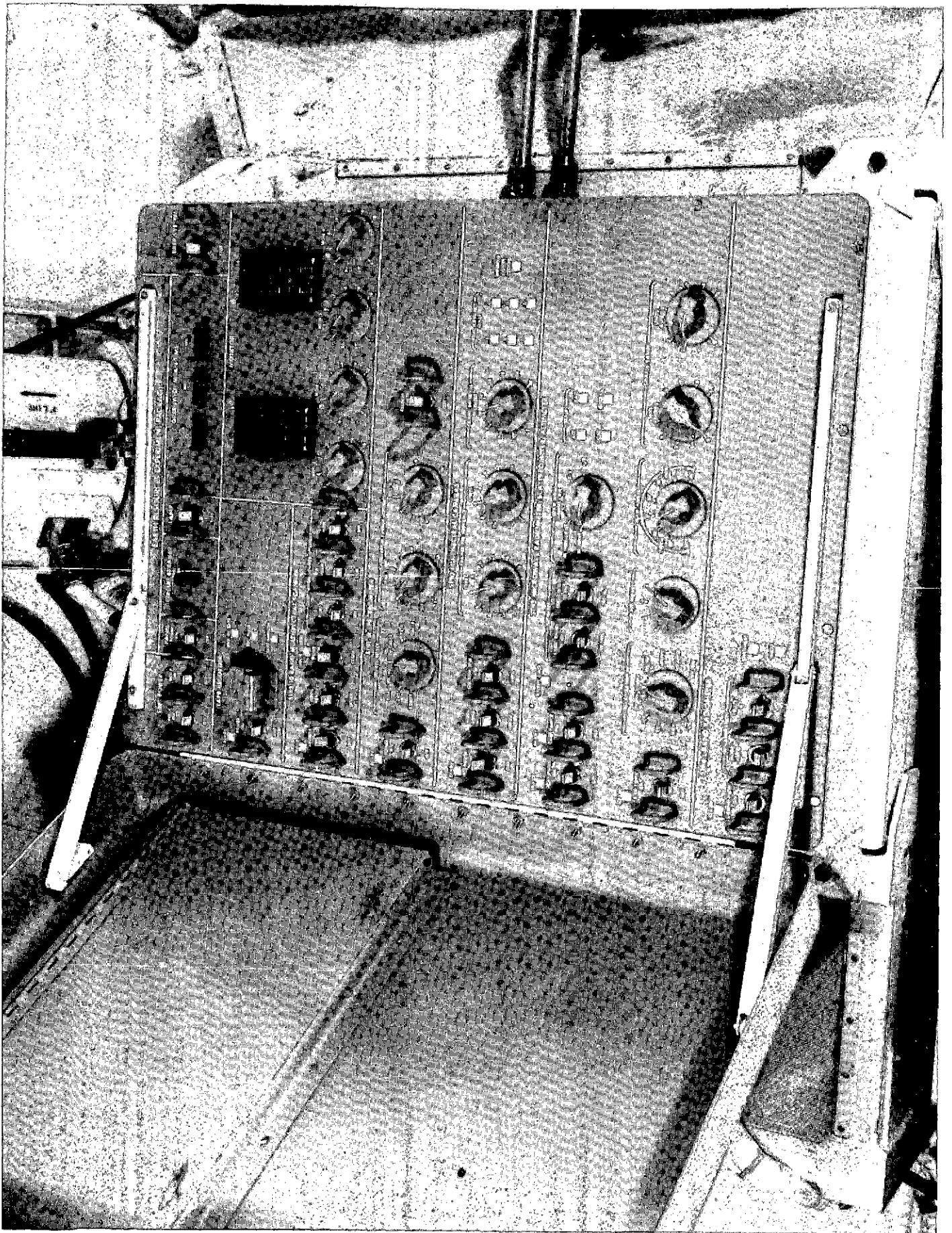

CONTROLS & DISPLAYS PANEL

MARTIN MARIETTA

DENVER DIVISION

Interfaces & Requirements

Control
&
Display
Panel

- Power Control
- Checkout
- Calibration
- Malfunction Detection
- Data Taking & Sequencing

Tape
Recorder

L-Band
Radiometer

IR
Spectrometer

10 Band
Multispectral
Scanner

Multispectral
Camera Facility

Microwave
Rad/Scat
Altimeter

CONTROL PANEL & COVER ASSY

MARTIN MARIETTA

DENVER DIVISION

1. Cover Assy:
 - a. 6061T6 Sheet Alum, Welded Construction.
 - b. Hinged to Left Side of Panel, with Cover Lock on Right Side.
 - c. Sliding Arm Retention Mechanism with Friction Lock to Maintain Cover Position.

2. Panel
 - a. All Hardware Explosion Proof, Hermetically Sealed or Beta Bagged.
 - b. Switch Guards (Wickets) Protect All Toggle Switches.
 - c. All Hardware is Apollo Approved.

3. Wiring
 - a. Approx 500 Wire Segments.
 - b. Wire is ML Coated, 12, 20 & 24 Ga.
 - c. All Soldered Connections are Conformal
 - d. Harness Routed Along and String Tied to Stiffening Ribs.
 - e. Abrasion Protection Provided to Prevent Wire Damage.

CONTROL & DISPLAY PANEL

MARTIN MARIETTA
DENVER DIVISION

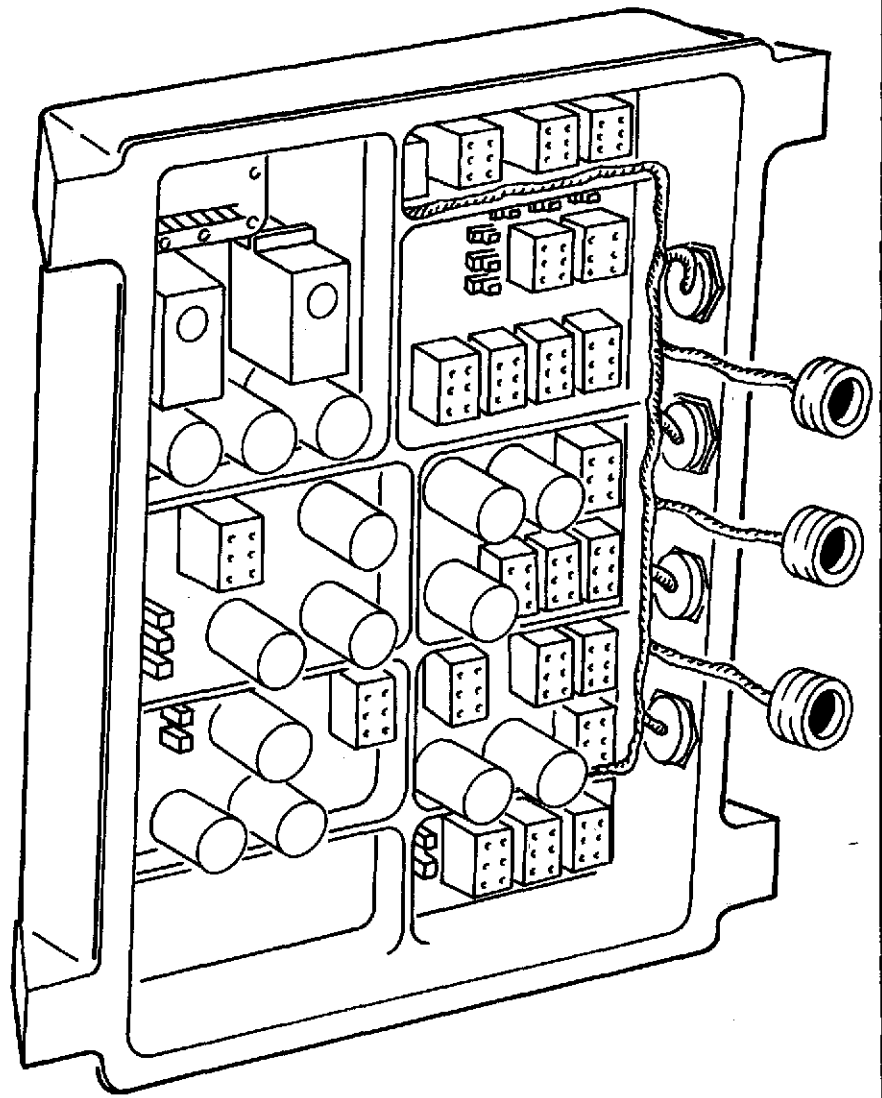
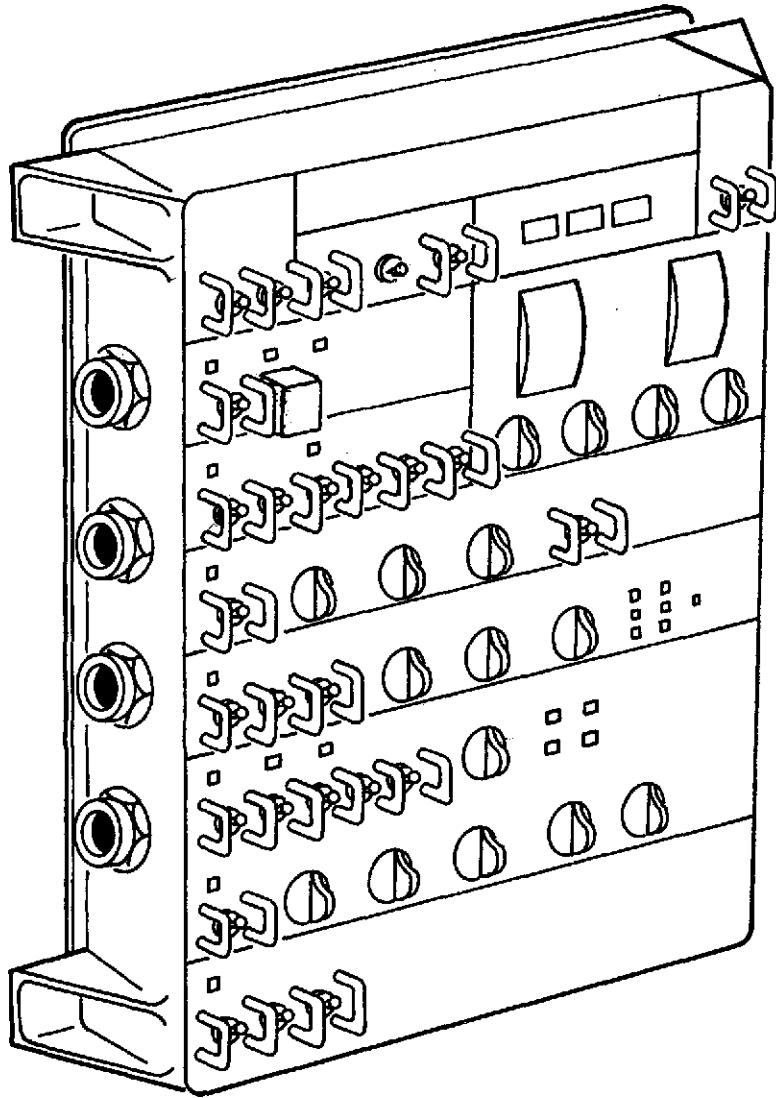

POWER SUPPLY AND COLD PLATE

1. Power Supply
 - a. Planar P.C. Board Construction Using 4 Double Sided Boards.
 - b. Boards Mounted within an EMI Enclosure
 - c. Compartmentalized Design with Feed Thrus Between Compartments.
 - d. All Heat Producing Components are Bonded to Heat Sinks.
 - e. Power Supply Outputs are Thru Two Connectors.

2. Cold Plate
 - a. Cooling Tube is 3/8 Dia Alum, Brazed to Under Side of Case.
 - b. Water Inlet Temp. 78°F Max.
 - c. Flow Rate = 110 lbs/Hr
 - d. Maximum Heat Rate to Cold Plate: $250 \frac{\text{BTU}}{\text{hr}}$
 - e. Effective Length of Cooling Tube: 12 ft.
 - f. Analysis Performed on CINDA-3G Computer Program

C & D POWER SUPPLY

MARTIN MARIETTA
DENVER DIVISION

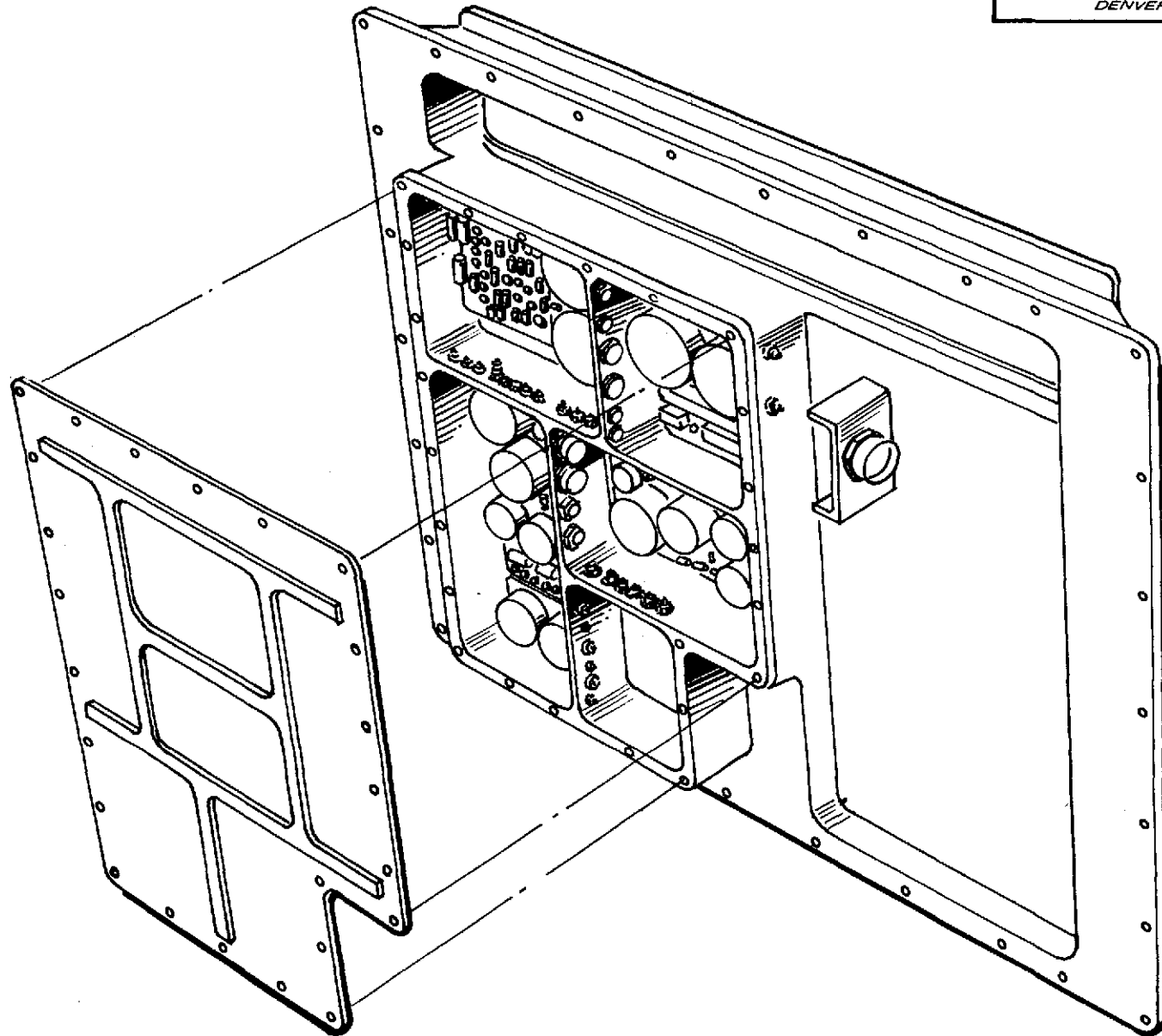

C & D POWER SUPPLY

MARTIN MARIETTA
DENVER DIVISION

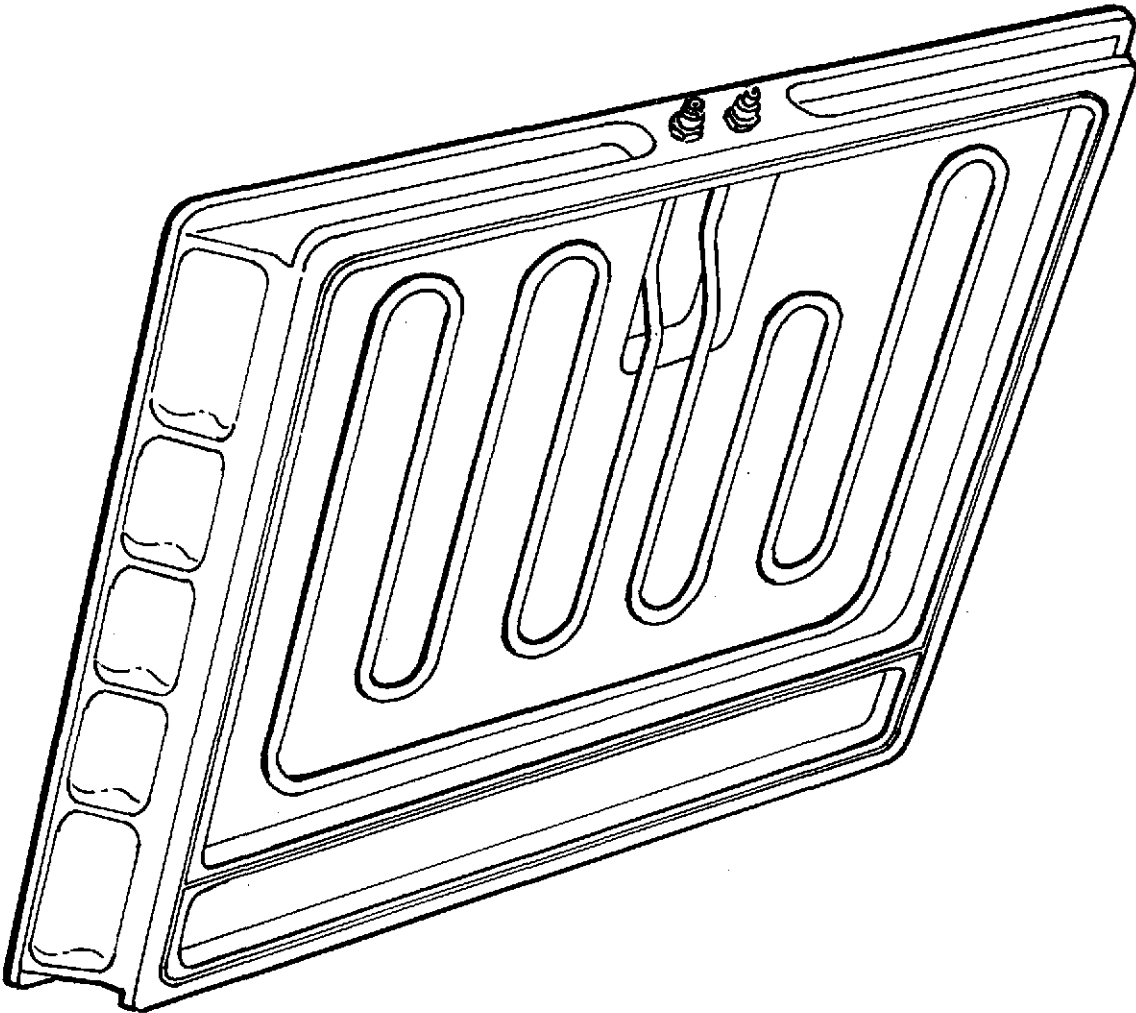

Includes Logic and Modem Electronics

1. Board Assemblies
 - a. 4 Layer Boards with Power and Ground Planes on Internal Layers.
 - b. Maximum of 8 Dual in Lines and 1 Capacitor on each Board.
 - c. 1-32 Pin Microdot Connector Per Board.
 - d. Boards are Conformal Coated.
 - e. Approx 105 Board Assy's of 17 Different Types.
 - f. Connectors are Individually Keyed.

2. Mother Board and Wiring
 - a. 130 Mating Microdot Connectors.
 - b. Interconnecting Wire is 26 Ga. ML Coated, Approx. 4000 Wire Segments.
 - c. Wire Terminations on Staggered .10 Grid or on .14 x .20 centers.
 - d. Wires Terminated to Connector Pins Using Raychem Solder Sleeves.
 - e. Wires to Connectors off the Board is 24 Ga. ML Coated.

LOGIC DECK

MARTIN MARIETTA
DENVER DIVISION

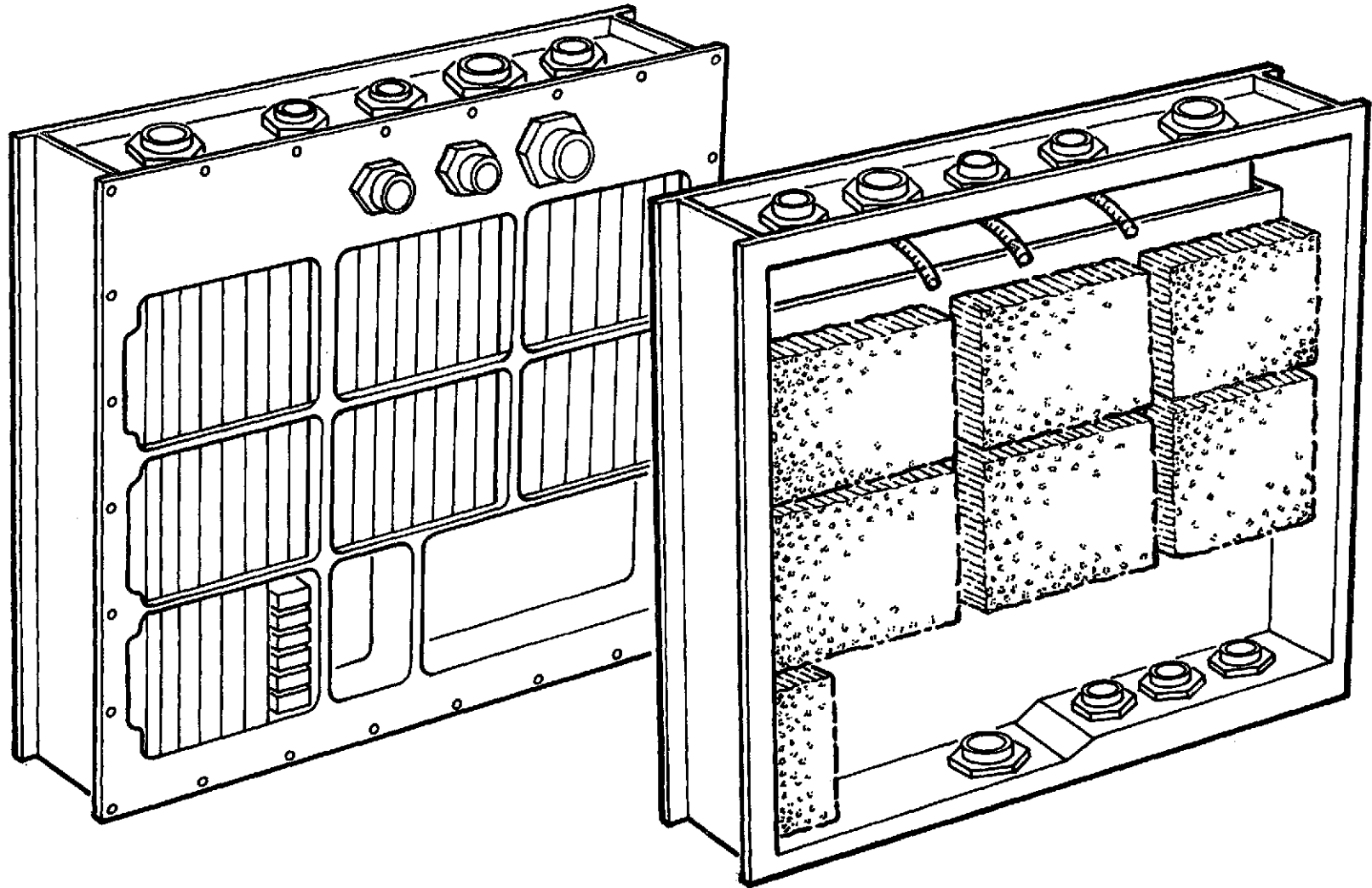

LOGIC DECK PACKAGING

MARTIN MARIETTA
DENVER DIVISION

BABY-BOARD RESTRAINT RAILS

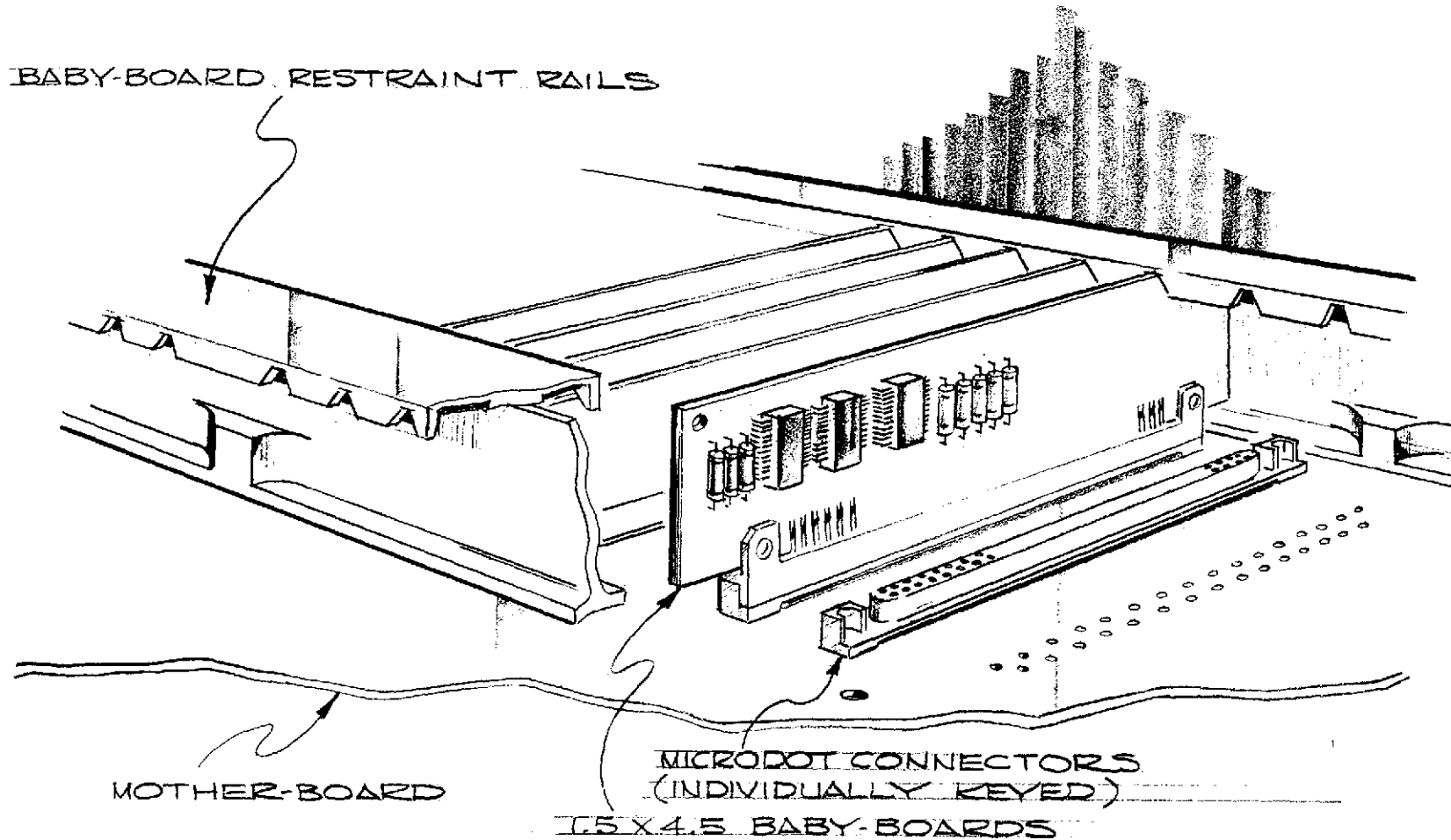

MOTHER-BOARD

MICRODOT CONNECTORS
(INDIVIDUALLY KEVED)

15 X 4.5 BABY-BOARDS

20

CDR MOCKUP FIDELITY DESCRIPTION



- V/TS - Headrest Is Low Fidelity. Remainder of Mockups Correct in Size and Shape of Flight Hardware Except for Pencil Controller. Clipboard Representative of Installed Configuration, But Is Not Removable in Accordance with Design. Second Clipboard Is Installed on Rack and Represent Stowage, Remove and Replace
- S-190 Camera Mount Assembly - Duplicates Flight Hardware Including Mechanical Operation
- Rack 1, 2, & 3 - Minor Variations from Flight Hardware, Including Square Tubing. Screen in Liew of Expanded Aluminum Closeouts
- C&D Panel - Duplicates Flight Hardware
- Tape Recorder Primary - Duplicates Flight Hardware
- Tape Recorder (Backup In Rack #3) - External Representation of Flight Hardware
- S-190 Equipment Container - Size Fidelity Only. This Mockups Was Tape Reels - Flight Type Reels. Empty Reel Stowage on Rack #1 Represents Flight Hardware
- S-190 Equipment Container - Size Fidelity Only. This Mockups Was Not Updated Due to Lack of Definition of Contents. Flight Article Will Have A Single Lid
- Magnetic Tape Handling Container - Flight Type
- Coolant Management System (by Pass and T/R Select Valves) Not Included - Gate Definition'
- GFP Mockups -
 - S-190 Camera Arroy
 - S-192 IR Scanner
 - IR Scanner Electronics
 - VTS Electronics
- MSFC Mockups -
 - Level A Cabling
 - Level A Coolant Tubing

EREP PROGRAM SCHEDULE

MARTIN MARIETTA
DENVER DIVISION

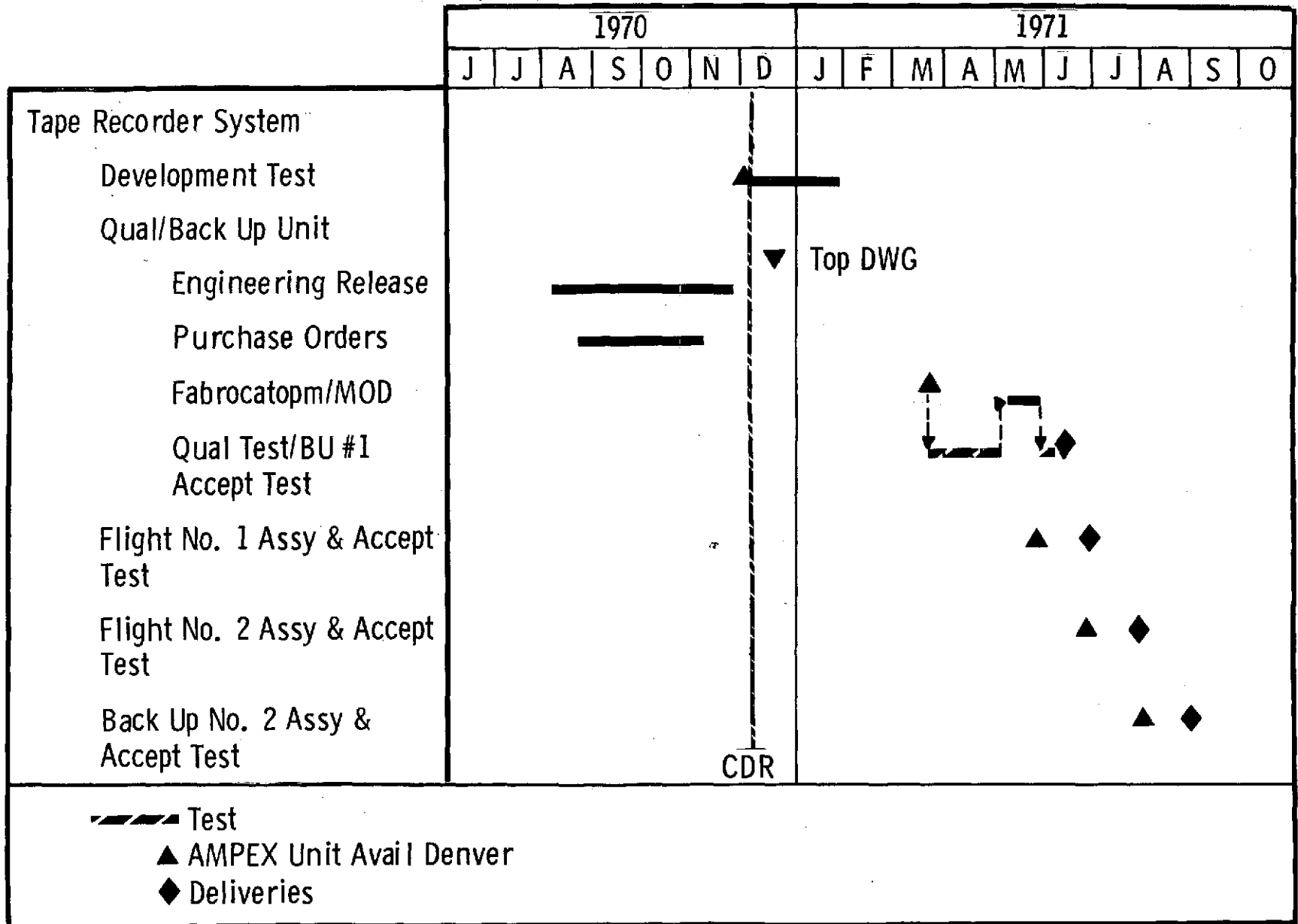

EREP PROGRAM SCHEDULE

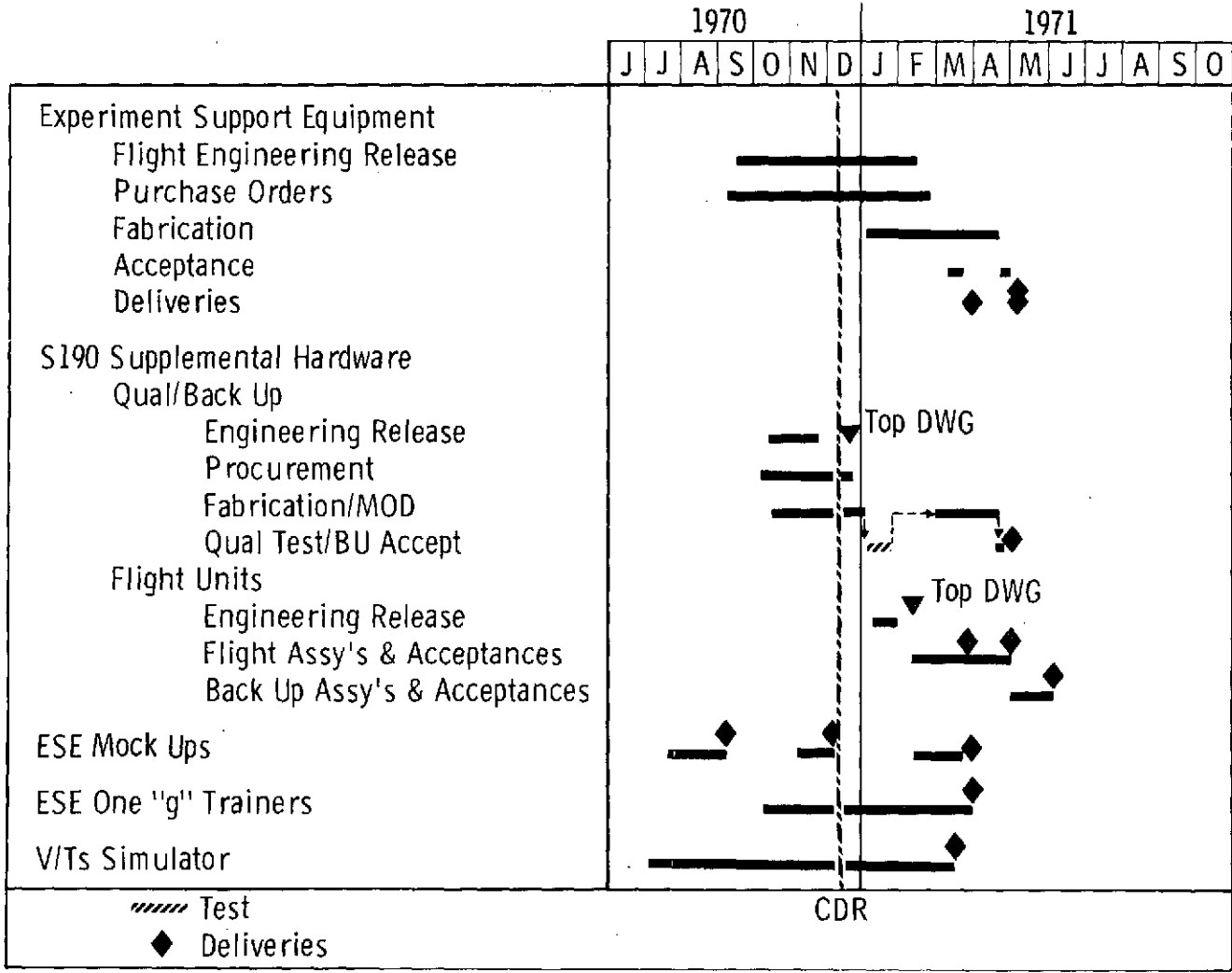

EREP PROGRAM SCHEDULE

MARTIN MARIETTA
DENVER DIVISION

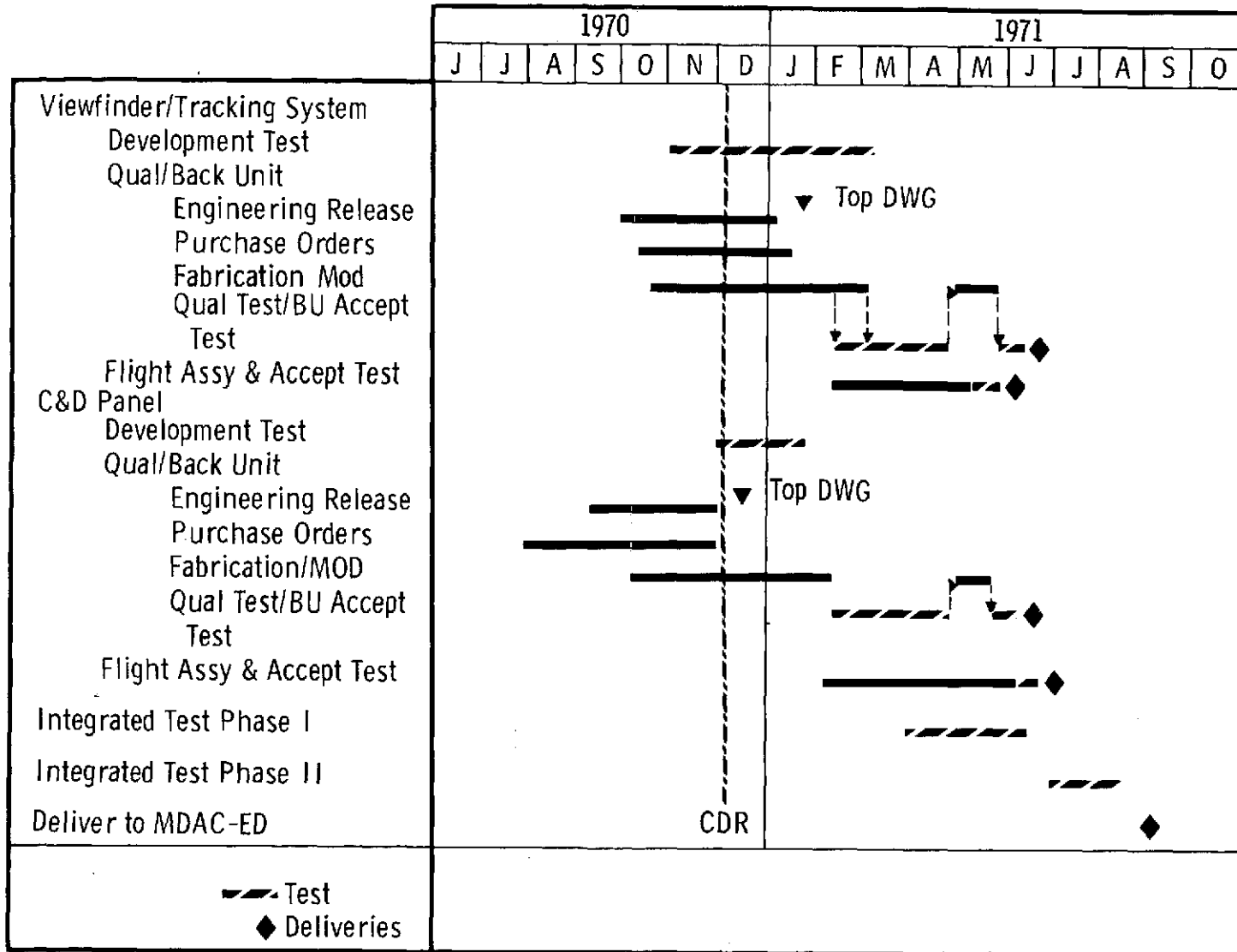

EARTH RESOURCES EXPERIMENT PACKAGE

MARTIN MARIETTA
DENVER DIVISION

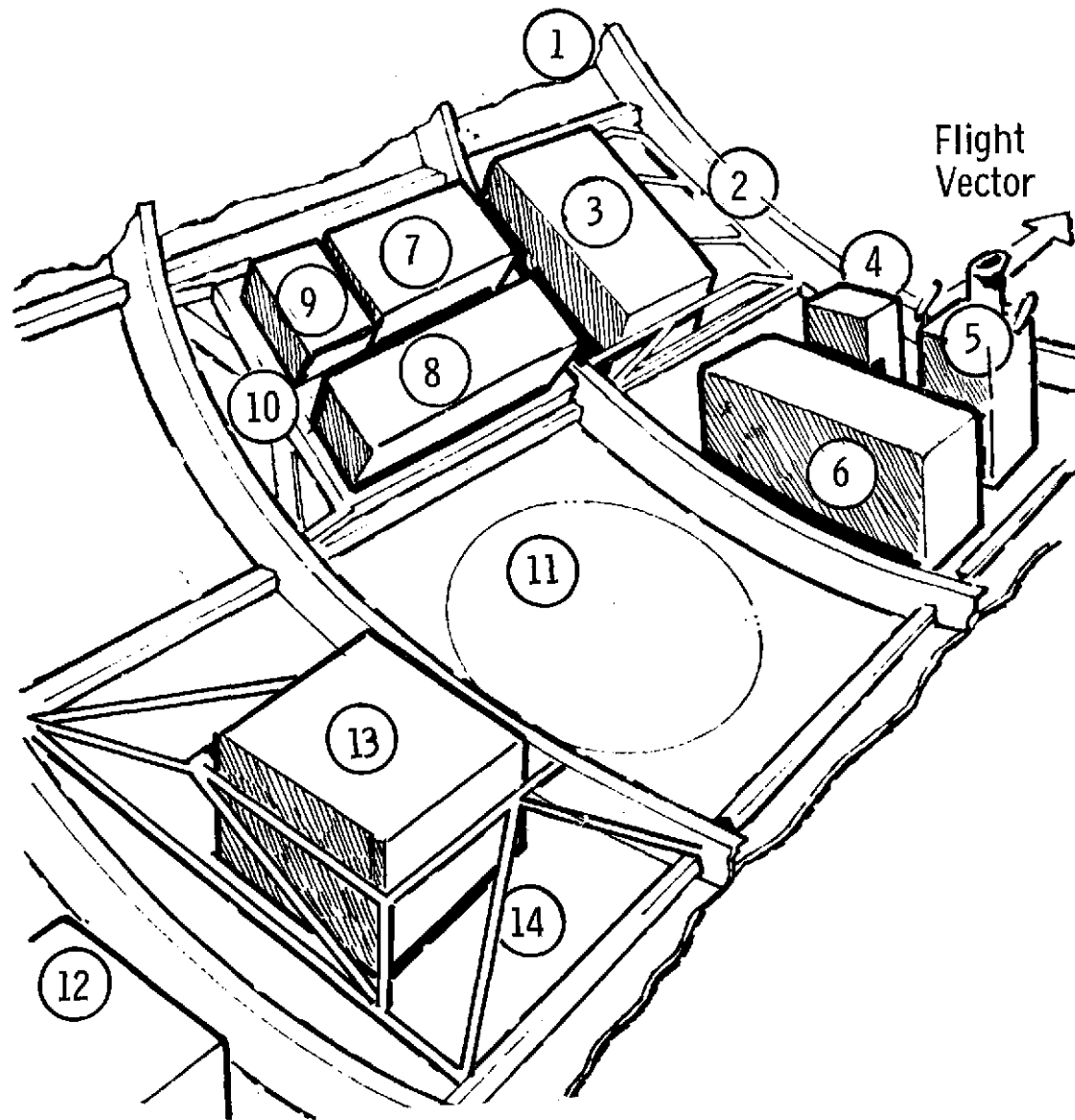

Legend:

- 1 Fwd Frame - Barrel - MDA
- 2 ESE Rack No. 1
- 3 C&D Panel
- 4 IR Spectrometer Elec
- 5 Viewfinder/Tracking System
- 6 S190
- 7 Tape Recorder
- 8 S190 Stowage, Tape Stowage
- 9 S192 Electronics Assembly
- 10 ESE Rack No. 2
- 11 Docking Port
- 12 10-Band Multispectral Scanner (Internal)
- 13 Spare Tape Recorder
- 14 Spare Tape Recorder Support

EREP

Tape Recorder

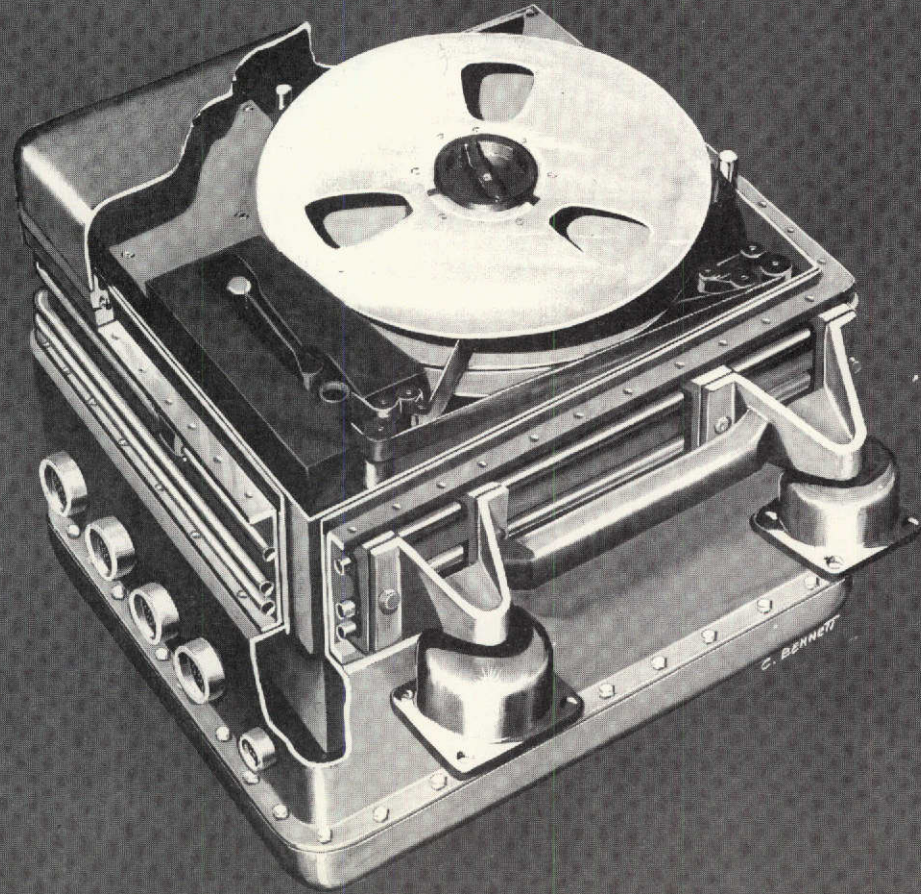

EREP C & D PANEL

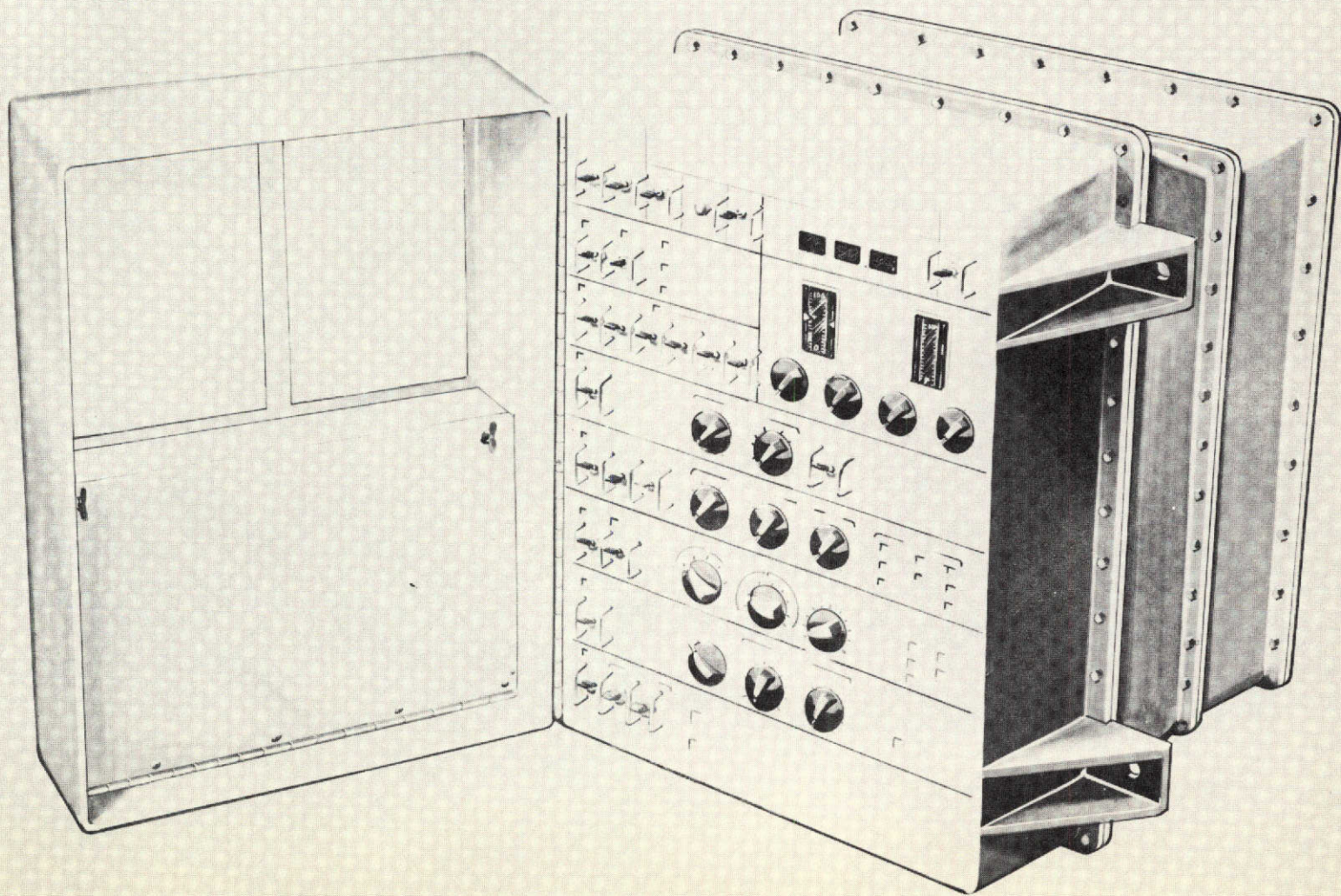

ESES - *Equipment Support Racks*

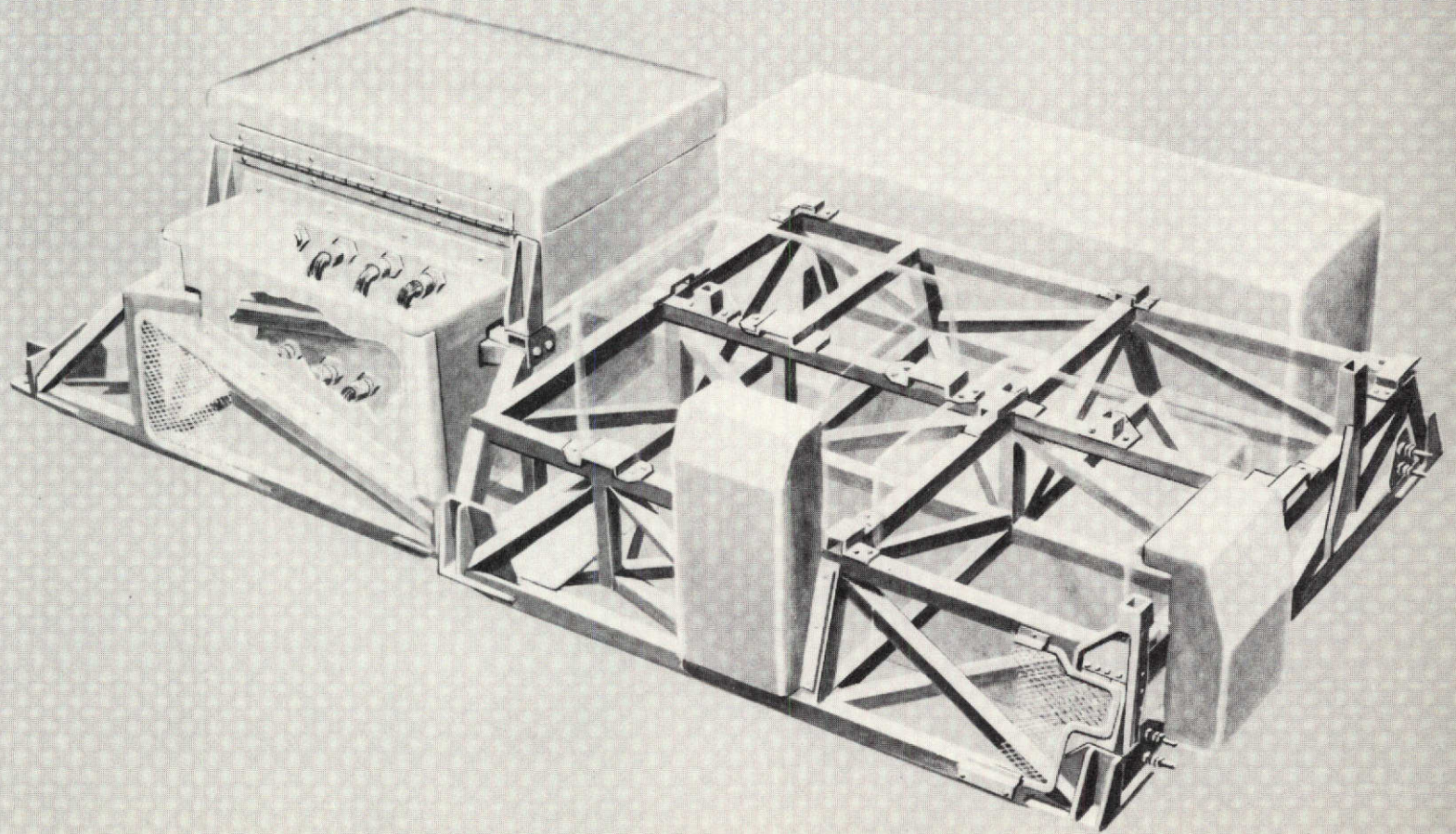

ESES - *Equipment Support Rack*

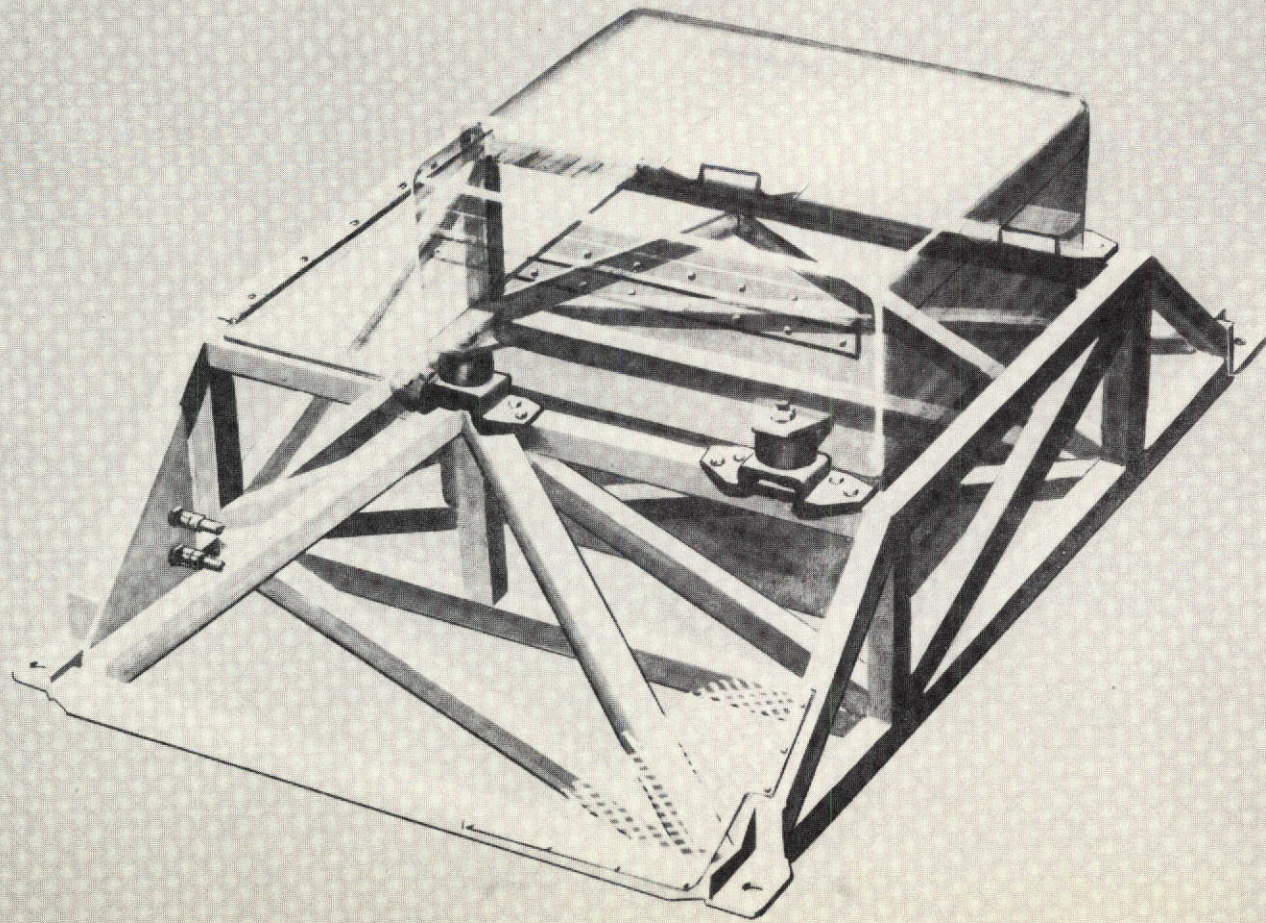

VIEW FINDER / TRACKING SYSTEM

V/TS Control Panel

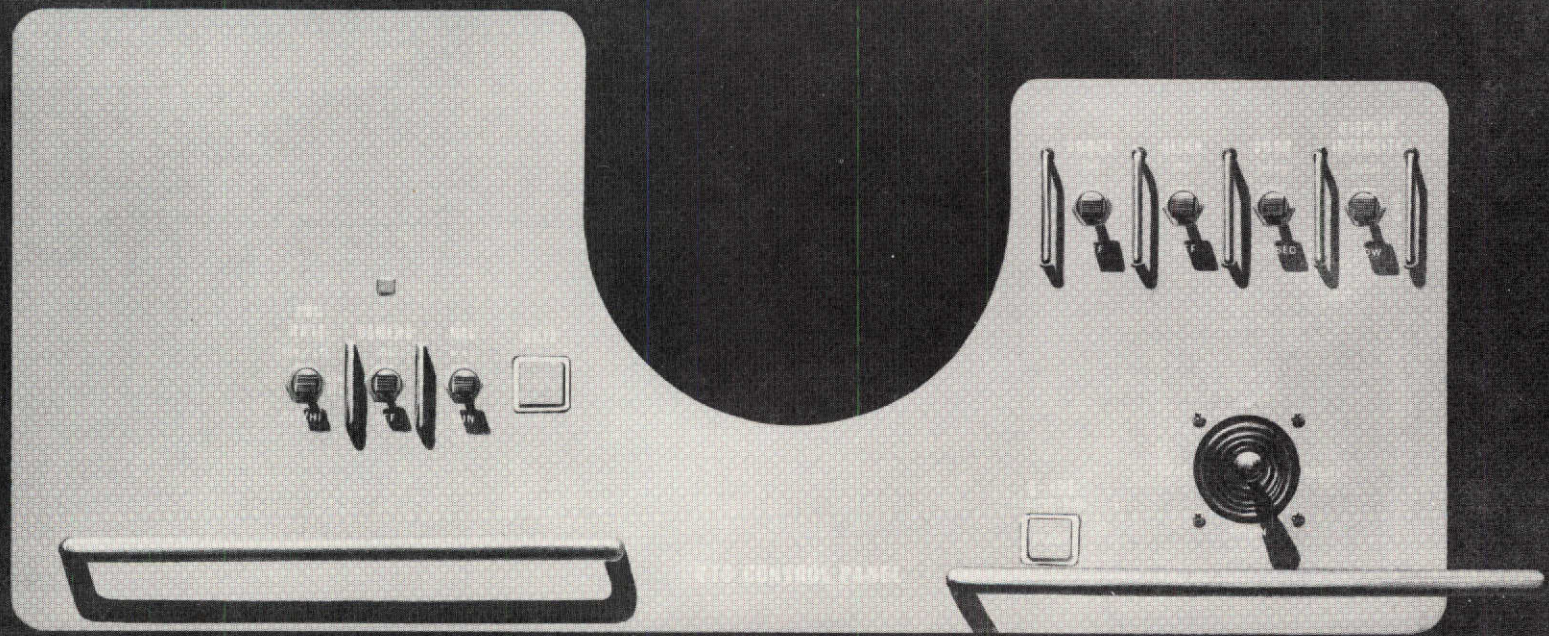

VIEWFINDER/TRACKING SYSTEM

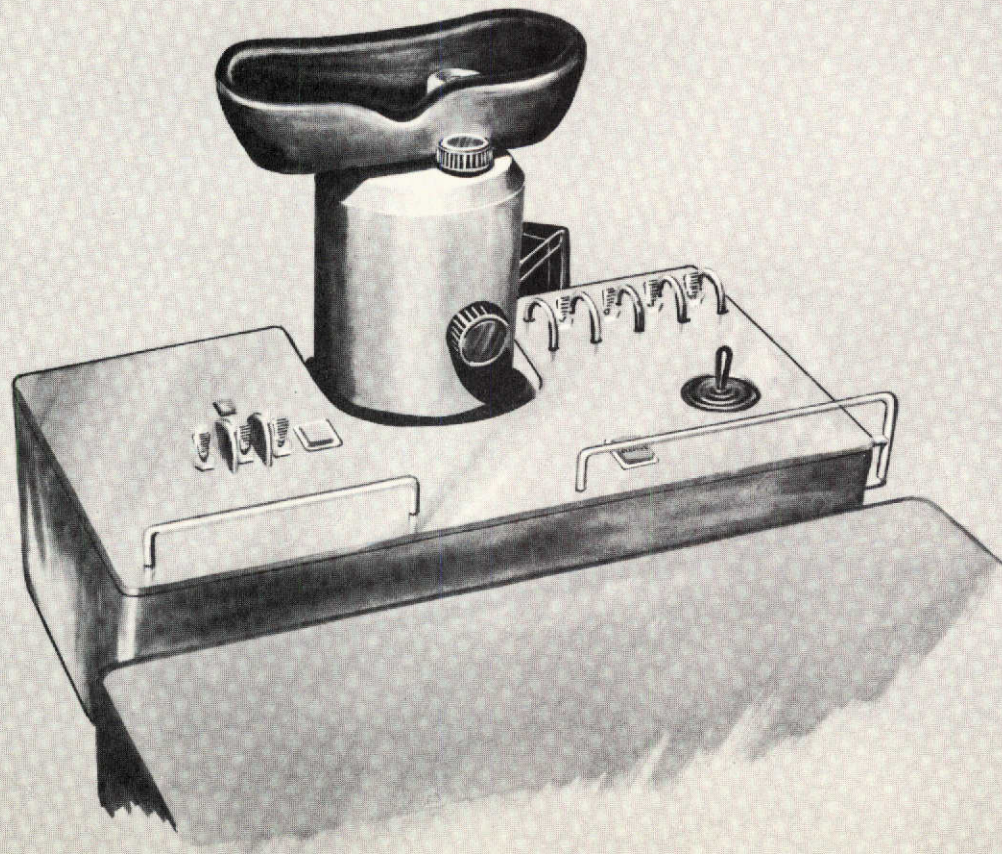

VIEWFINDER / TRACKING SYSTEM

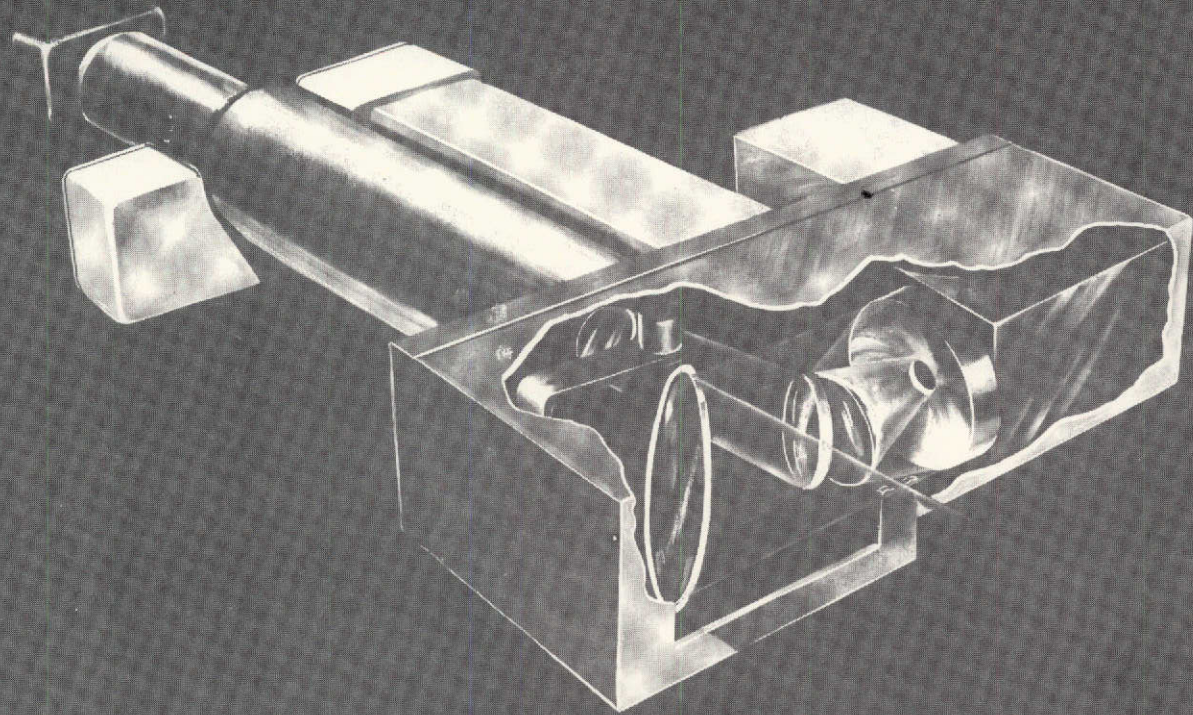

VIEWFINDER/TRACKING SYSTEM

Simulator

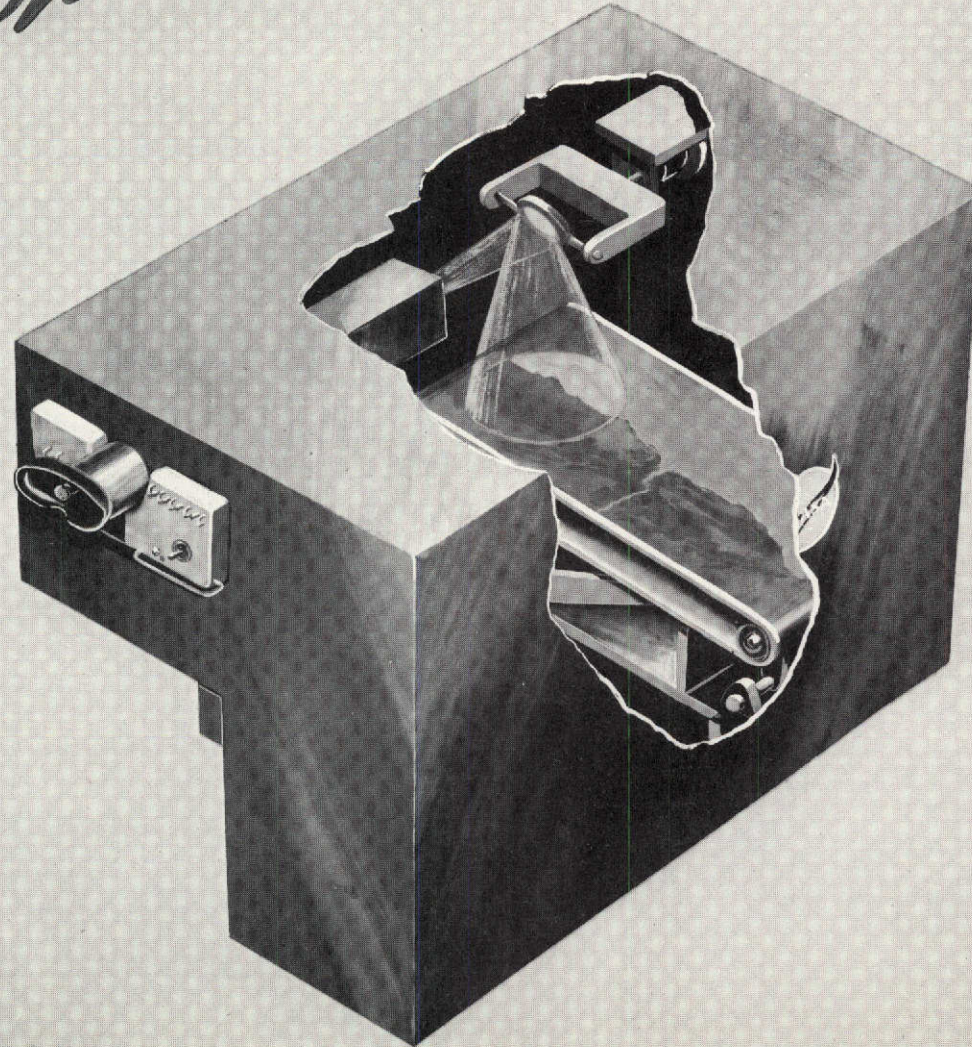

VIEWFINDER / TRACKING SYSTEM

Simulator Telescope

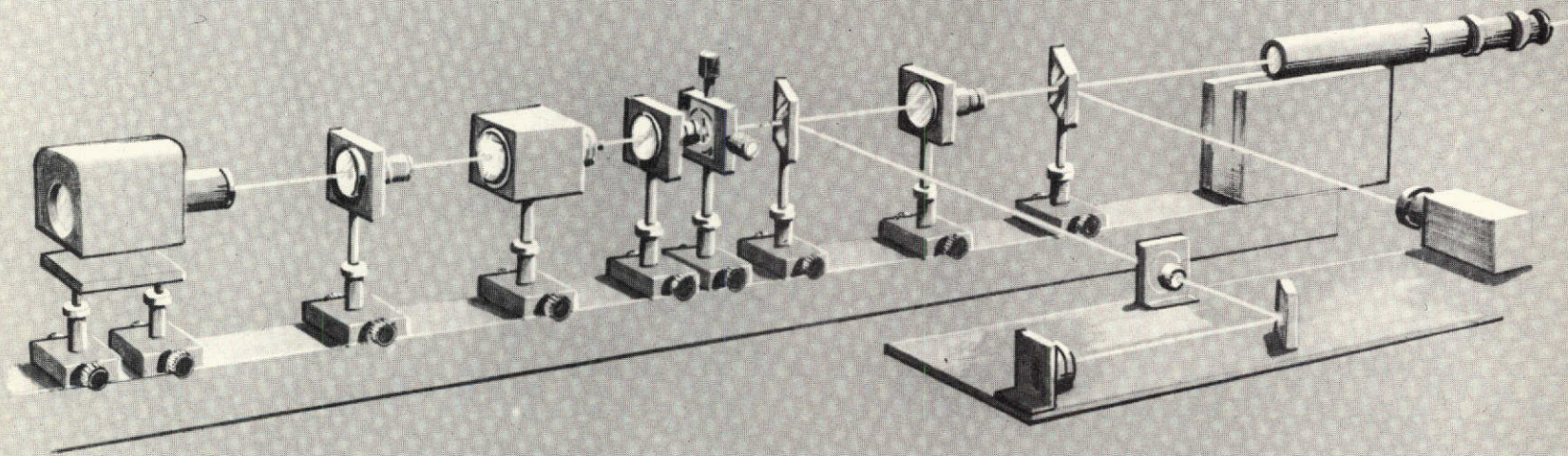

VIEW FINDER / TRACKING SYSTEM

Telescope Display

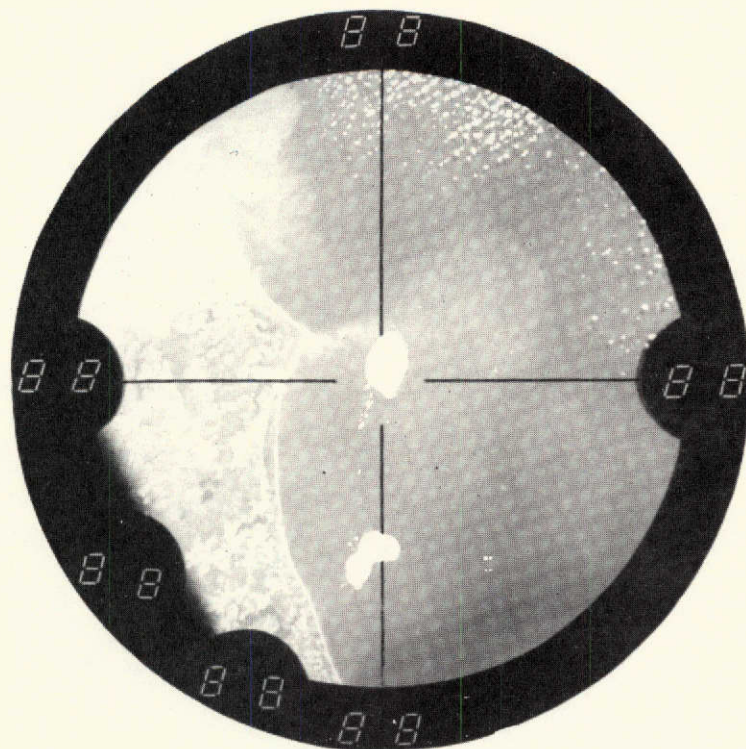

VIEWFINDER/TRACKING SYSTEM

Telescope

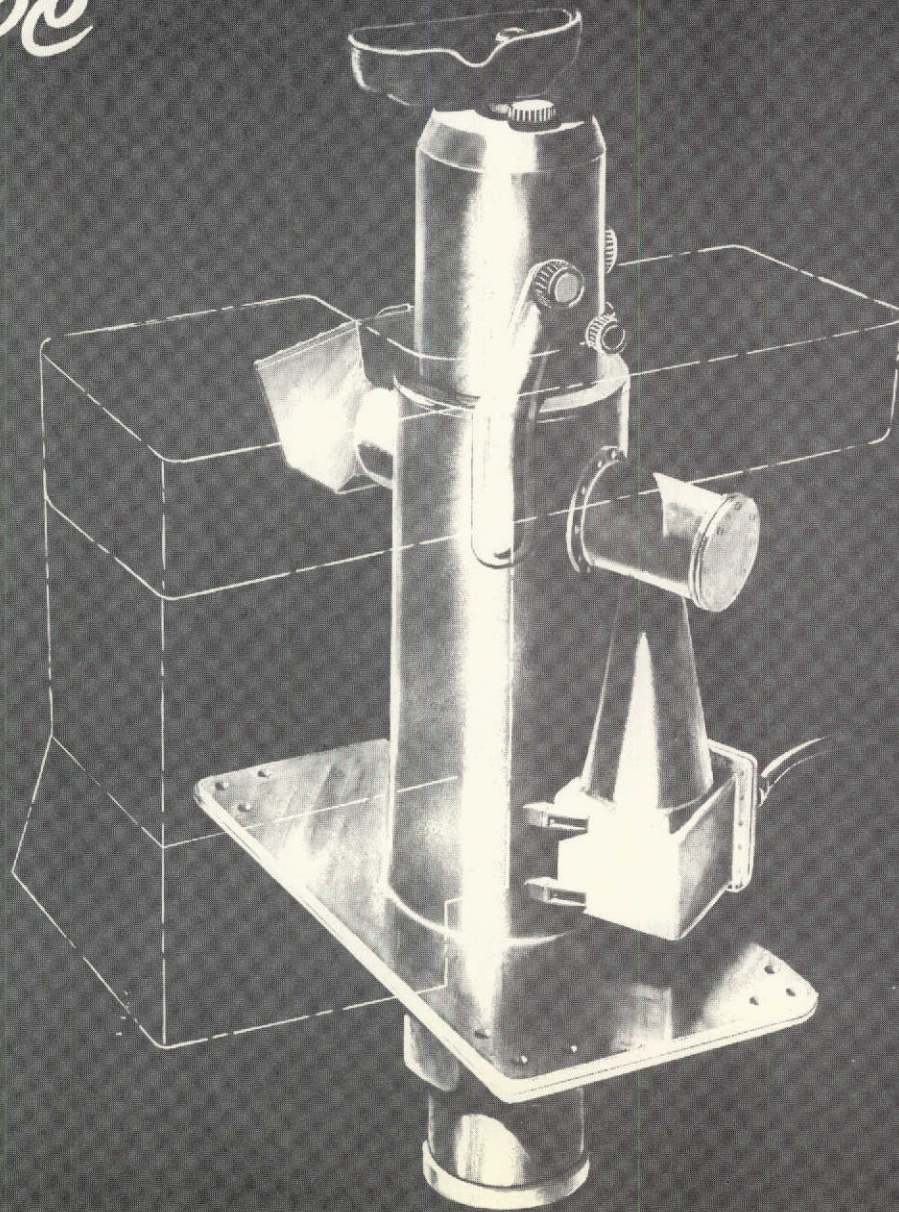

VIEWFINDER / TRACKING SYSTEM

Telescope

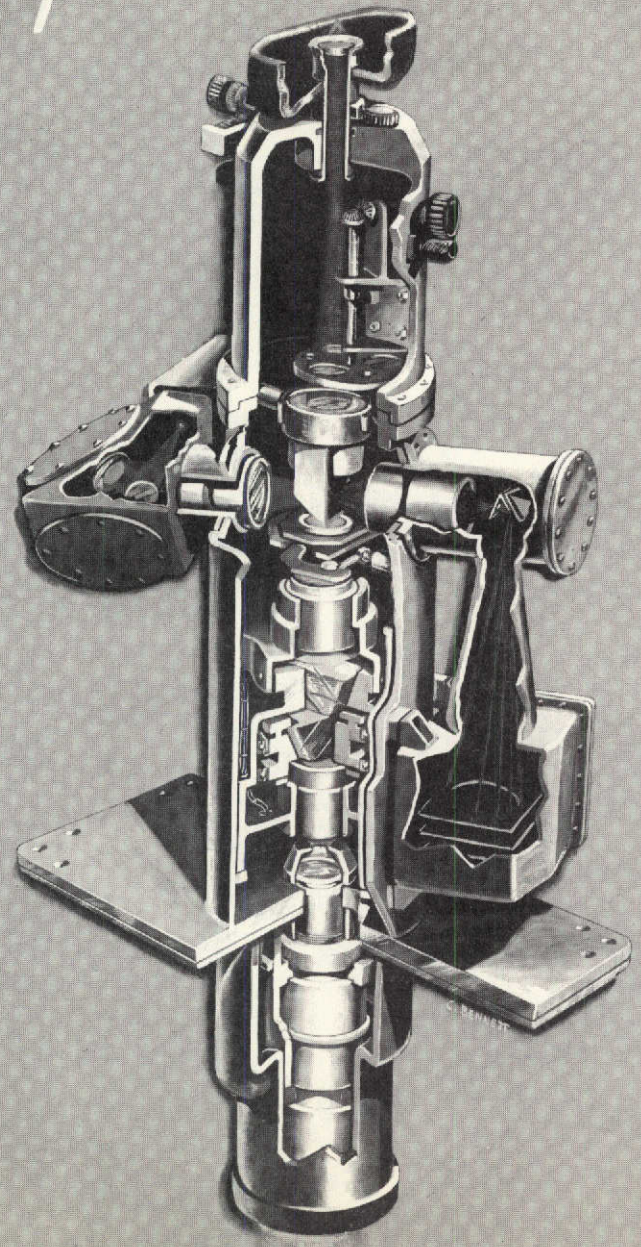

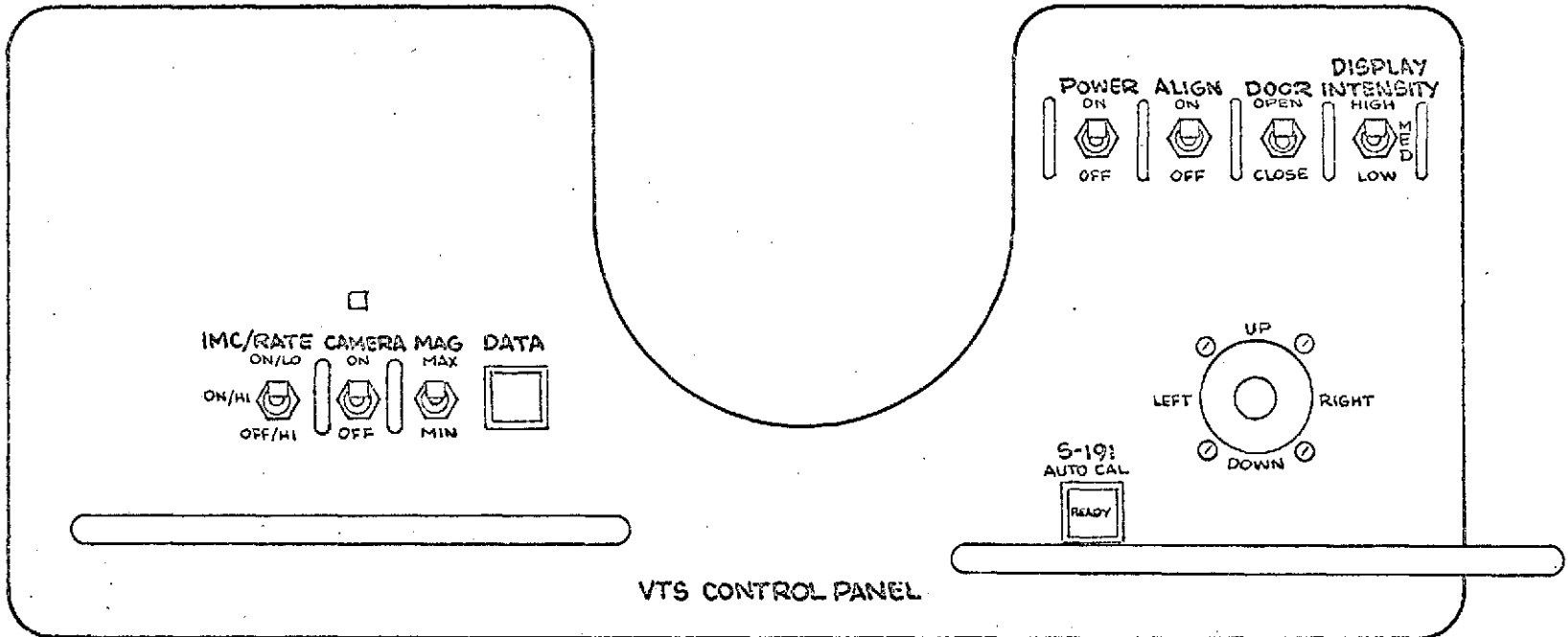

VTS CONTROL PANEL