

NASA TECHNICAL NOTE



NASA TN D-7517

NASA TN D-7517

(NASA-TN-D-7517) LOW TEMPERATURE  
COEFFICIENT OF RESISTANCE AND HIGH GAGE  
FACTOR IN BERYLLIUM-DOPED SILICON (NASA)  
17 p HC \$3.00 CSCL 11D

N74-23128

H1/18 Unclass  
39124



LOW TEMPERATURE COEFFICIENT OF  
RESISTANCE AND HIGH GAGE FACTOR  
IN BERYLLIUM-DOPED SILICON

*by J. B. Robertson and M. A. Littlejohn*

*Langley Research Center*

*Hampton, Va. 23665*



1. Report No. NASA TN D-7517		2. Government Accession No.		3. Recipient's Catalog No.	
4. Title and Subtitle LOW TEMPERATURE COEFFICIENT OF RESISTANCE AND HIGH GAGE FACTOR IN BERYLLIUM-DOPED SILICON				5. Report Date June 1974	
				6. Performing Organization Code	
7. Author(s) J. B. Robertson (Langley Research Center) and M. A. Littlejohn (North Carolina State University)				8. Performing Organization Report No. L-9297	
9. Performing Organization Name and Address NASA Langley Research Center Hampton, Va. 23665				10. Work Unit No. 502-03-51-01	
				11. Contract or Grant No.	
12. Sponsoring Agency Name and Address National Aeronautics and Space Administration Washington, D.C. 20546				13. Type of Report and Period Covered Technical Note	
				14. Sponsoring Agency Code	
15. Supplementary Notes					
16. Abstract <p>The gage factor and resistivity of p-type silicon doped with beryllium was studied as a function of temperature, crystal orientation, and beryllium doping concentration. It was shown that the temperature coefficient of resistance can be varied and reduced to zero near room temperature by varying the beryllium doping level. Similarly, the magnitude of the piezoresistance gage factor for beryllium-doped silicon is slightly larger than for silicon doped with a shallow acceptor impurity such as boron, whereas the temperature coefficient of piezoresistance is about the same for material containing these two dopants. These results are discussed in terms of a model for the piezoresistance of compensated p-type silicon.</p>					
17. Key Words (Suggested by Author(s)) Gage factor Beryllium-doped silicon Coefficient of resistance				18. Distribution Statement Unclassified - Unlimited  STAR Category 18	
19. Security Classif. (of this report) Unclassified		20. Security Classif. (of this page) Unclassified		21. No. of Pages 18	22. Price* \$3.00

# LOW TEMPERATURE COEFFICIENT OF RESISTANCE AND HIGH GAGE FACTOR IN BERYLLIUM-DOPED SILICON

By J. B. Robertson and M. A. Littlejohn\*  
Langley Research Center

## SUMMARY

The gage factor and resistivity of p-type silicon doped with beryllium was studied as a function of temperature, crystal orientation, and beryllium doping concentration. It was shown that the temperature coefficient of resistance can be varied and reduced to zero near room temperature by varying the beryllium doping level. Similarly, the magnitude of the piezoresistance gage factor for beryllium-doped silicon is slightly larger than for silicon doped with a shallow acceptor impurity such as boron, whereas the temperature coefficient of piezoresistance is about the same for material containing these two dopants. These results are discussed in terms of a model for the piezoresistance of compensated p-type silicon.

## INTRODUCTION

Semiconductor strain gages are nearly 100 times more sensitive to strain than metal foil gages and have excellent response times. These semiconductor gages, however, have the disadvantage of having large temperature coefficients of resistivity and temperature coefficients of gage factor. This problem has been countered primarily by use of compensating circuits and by adjusting the impurity concentration in the material for minimum temperature effect. Also, electron irradiation of silicon gages (refs. 1, 2, and 3) has been used to substantially reduce the temperature coefficient of resistivity and in some cases to reduce the temperature coefficient of gage factor in these gages.

Based on the results for electron-irradiated silicon (refs. 1, 2, and 3) and the physics of the carrier compensation process, one would expect that the thermal characteristics of silicon strain gages could be varied by any impurity which has a deep energy level in silicon. (See ref. 3.) The primary requirements are that the Fermi energy at the desired temperature must lie near the energy level in question and that the impurity must be present in a large enough concentration to cause the majority carrier concentration to vary with temperature near the temperature of interest. Once these requirements

---

\*North Carolina State University.

are satisfied, then the thermal variations of resistivity and piezoresistance will be determined primarily by the impurities present in the material, the condition of charge neutrality, and the effects of strain on the energy levels and the semiconductor band parameters.

It has been shown that the temperature coefficient of resistivity can be easily reduced to a zero value near room temperature by diffusing beryllium into high purity p-type silicon. (See ref. 4.) This indicates that the majority carrier concentration does vary with temperature in this temperature range. Also, it is known that beryllium has two acceptorlike centers in silicon whose ground state energies are at 0.145 eV and 0.190 eV above the valence band edge. (See ref. 5.) These results were deduced from infrared absorption spectroscopy. However, when the temperature dependence of the Hall coefficient is studied, these two levels appear to be one acceptor level at approximately 0.168 eV above the valence band edge (ref. 6). Thus, for typical values of mobility in p-type silicon (ref. 7), the Fermi energy would be located near this "average level" for resistivities of approximately 1 ohm-cm. Resistivities near this value are easily achieved by beryllium diffusion. Thus, it appears that beryllium satisfies the necessary requirements for varying the thermal properties of p-type silicon strain gages.

This paper presents the results of piezoresistance and resistivity measurements on beryllium-doped silicon gages which show that these gages can be made which have a zero temperature coefficient of resistivity at room temperature, a gage factor over 200, and a temperature coefficient of gage factor equal to that of boron-doped silicon gages, which are the most frequently used type of silicon gages.

#### SYMBOLS AND ABBREVIATIONS

$E_{\text{Be}}$	beryllium activation energy
$E_f$	Fermi energy
$f$	Fermi probability function
$G_F$	gage factor
$G_F^{(0)}$	gage factor due to band changes only
$k$	Boltzmann constant, $8.616 \times 10^{-5}$ eV/K
$N_A$	acceptor concentration

$N_{\text{Be}}$	beryllium concentration
$N_{\text{V}}$	valence band effective density of states
$p$	hole concentration
$p_i$	hole concentration in $i$ th valence band
$p_0$	hole concentration in unstrained material
$q$	electronic charge
$R_0$	resistance for zero strain
$R(\epsilon)$	resistance as a function of strain
$T$	temperature, kelvins
$\Delta_{\text{Be}}$	change in beryllium energy level due to strain
$\Delta E_{\text{V,eff}}$	effective shift in valence band edge
$\Delta E_{\text{V}i}$	shift in individual valence bands
$\Delta E_{\text{f}}$	change in Fermi energy with strain
$\Delta_{\text{f}}, \Delta_{\text{V,eff}}$	deformation potentials (see eqs. (15))
$\epsilon$	strain
$\mu$	carrier mobility
$\mu_{\text{eff}} = \sum \mu_i \frac{p_i}{p}$	
$\mu_i$	mobility of holes in silicon in $i$ th band
$\mu_{\text{p}}$	hole mobility
$\nu$	Poisson's ratio

$\rho$	electrical resistivity
$\sigma$	conductivity, (ohm-cm) <sup>-1</sup>
TCGF	temperature coefficient of gage factor
TCR	temperature coefficient of resistivity

## EXPERIMENTAL TECHNIQUES

The material used was obtained by thermal diffusion of beryllium into high purity, single-crystal, p-type silicon ( $\rho > 100$  ohm-cm). Silicon wafers, 2.5 cm in diameter and 0.10 cm thick, were plated on both sides with beryllium using vapor deposition. The plated wafer was sandwiched between two clean silicon wafers and placed in a furnace in a helium environment. The samples were heated at 1300<sup>o</sup> C for 1 hr. After diffusion, the resistivity was approximately 0.2 ohm-cm p-type, which represents the solubility limit of beryllium in silicon. To obtain resistivities greater than 0.2 ohm-cm the beryllium concentration was reduced by heating the silicon at 1100<sup>o</sup> C until the desired resistivity was reached. Resistivities as high as 7 ohm-cm could be easily achieved.

The wafer was mechanically lapped to a thickness of about 0.025 cm. The resistivity profile over the surface was examined by using a four-point probe. The variation in the resistivity over the region of the wafer from which samples were cut was typically 20 percent. After final lapping the crystal orientation was determined by X-ray diffraction and by optical goniometer.

Bridge-shaped strain-gage samples were cut from the wafers with an ultrasonic cutter. The samples were then chemically polished and ohmic contacts formed with evaporated aluminum. The aluminum was alloyed at 600<sup>o</sup> C for 10 minutes in an argon atmosphere. Immediately after alloying, the aluminum contacts were nickel plated to enhance the uniformity of the contact. The final active dimensions of the strain-gage samples were approximately 0.51 cm by 0.191 cm by 0.018 cm.

The strain gages were mounted to stainless-steel cantilever beams having dimensions 15.2 cm by 2.54 cm by 0.254 cm. First, the area of the beam to which the gage was to be mounted was sandblasted and chemically cleaned. An initial coat of strain-gage epoxy was applied to the beam and cured for 1 hr at 250<sup>o</sup> C. Next, an additional coat of epoxy was applied, the sample was then fixed to the beam, and again the epoxy was cured at 250<sup>o</sup> C for 1 hr.

The cantilever beams were mounted in a cryostat, the bottom section of which is illustrated in figure 1. The temperature of the samples could be varied from about 90 K to 400 K, although most measurements were taken from 220 K to 375 K. Strain was applied to the sample by deflecting the beam with a micrometer which was thermally insulated from the beam. Both tensile and compressive strains could be applied.

The calculation of the strain in the beryllium-doped gage is very important in determining the actual magnitude of the piezoresistance gage factor. (This problem has been discussed in reference 8 for an end-loaded cantilever beam such as that used in the present investigation.) The approach taken herein was to first examine several (four in all) commercial gages, both metal and semiconductor, to determine the linearity of the system in figure 1. The results were quite good in that for each gage tested the normalized change in resistance as a function of the normalized deflection yielded a straight line with a slope of unity to within less than 5 percent. The same results were obtained for strains up to about  $10^{-3}$  cm/cm (calculated from the manufacturers' specified gage factors). Also, the strain levels deduced from the manufacturers' specified gage factors were in agreement with each other to within about 5 percent. However, these strains were consistently lower than the theoretical strain calculated from the beam dimensions and its deflection, as much as 15 percent lower. Since one of the purposes of the present study was to compare piezoresistance gage factors of beryllium-doped gages with those of boron-doped gages, the strain used in the calculations was the theoretical strain in an end-loaded cantilever beam. It is felt that this will provide a reasonably lower limit on the experimentally determined piezoresistance gage factors.

After a sample was mounted in the cryostat and contact wires were attached, the cryostat was assembled and evacuated to a pressure of 1.33 mPa ( $10^{-5}$  mm Hg). All measurements were taken under vacuum in the dark. The resistance was measured by passing a constant current from a current calibrator through the sample and measuring the voltage across the sample with a calibrated digital voltmeter. The accuracy of the resistance measurement was better than 0.1 percent. The temperature of the samples was controlled with a temperature controller and measured with a copper-constantan thermocouple. The accuracy was at least 1 percent, and caution was taken to insure that thermal equilibrium was established before any measurement was taken.

The nature of the epoxy bond was checked by examining the resistance change as a function deflection in both tension and compression up to strains of about  $10^{-3}$  cm/cm. Also, the gage was cycled between a strained and unstrained state many times and finally was left in a strained state for at least an hour before any thermal cycles were begun. Any indication of an appreciable built-in strain or creep in the bond resulted in the sample being discarded. The room-temperature gage factor was then measured at a strain

of about  $4.5 \times 10^{-4}$  cm/cm. Next, the piezoresistance was studied as a function of temperature. After the sample was returned to room temperature, the gage factor was measured again to make sure that the room temperature value had not changed due to degradation of the epoxy bond.

## EXPERIMENTAL RESULTS

### Transport Properties

The electrical transport properties of a material are of considerable interest in considering it for strain-gage applications. Thus, since one objective of this work was to compare strain gages of beryllium-doped silicon to boron-doped silicon, the transport properties of beryllium-doped silicon were studied.

The electrical resistivity  $\rho$  of any material is given by

$$\rho = \frac{1}{\sigma} = \frac{1}{nq\mu} \quad (1)$$

where  $\sigma$  is the conductivity,  $q$  is the electronic charge,  $n$  is the carrier concentration, and  $\mu$  is the carrier mobility. For a p-type semiconductor,

$$\rho = \frac{1}{pq\mu_p} \quad (2)$$

where  $p$  is the hole concentration and  $\mu_p$  is the hole mobility.

The dependence of resistivity on temperature will be determined by the dependence of the carrier concentration and the carrier mobility on temperature,

$$\rho(T) = \frac{1}{qp(T)\mu_p(T)} \quad (3)$$

Carrier mobility decreases with increasing temperature for the temperature range of interest. For holes in lightly doped silicon, the dependence is approximately  $\mu_p \propto T^{-2.7}$ . Carrier concentration in semiconductors increases with increasing temperature. In extrinsic (doped) silicon at temperatures less than 250° C, the carrier concentration is determined by thermal ionization of impurities. At sufficiently low temperatures, the percentage increase in carriers with temperature  $\frac{dp}{dT}/p$  is greater than the percentage decrease in mobility with temperature  $\frac{d\mu}{dT}/\mu_p$ , and consequently, the TCR will be negative. As the temperature increases, more carriers are ionized, and the supply of un-ionized impurities diminishes; thus, the increase of carriers is slowed. At sufficiently high temperatures, the percentage increase in carriers is less than the percentage decrease



in mobility, and, consequently, the TCR will be positive. At some intermediate temperature, therefore, the TCR must be zero, and the resistivity pass through a minimum. This occurs at the temperature where the increase in carriers is equal to the decrease in mobility. This condition is obtained mathematically by setting the derivative of equation (3) equal to zero, which gives

$$\frac{dp/dT}{p} = \frac{-d\mu_p/dT}{\mu_p} \quad (4)$$

The ionization energy of boron in silicon is 0.045 eV, and most of the boron is ionized at temperatures well below room temperature. As a result, the resistivity minimum of boron-doped silicon occurs between  $-175^{\circ}\text{C}$  and  $-75^{\circ}\text{C}$ . The effective ionization energy of beryllium in silicon is  $\approx 0.168$  eV. Therefore, a higher temperature is required to thermally ionize a fraction of beryllium impurities than is required to ionize the same fraction of boron impurities. As a result, the resistivity minimum in beryllium-doped silicon occurs at a higher temperature.

Figure 2 shows a plot of Hall mobility as a function of temperature for samples having hole concentrations at room temperature ranging from  $2.55 \times 10^{15} \text{ cm}^{-3}$  to  $1.65 \times 10^{17} \text{ cm}^{-3}$ . Also shown for comparison is the curve for  $T^{-2.7}$  dependence on temperature which is found for lightly doped p-type silicon (ref. 7). Figure 3 illustrates the dependence of the hole mobility on the hole concentration. The solid curve is based on calculations from an empirical relation given in reference 9, which was derived from experimental data reported in references 10, 11, and 12. Thus, the mobility values of beryllium-doped silicon and their temperature and carrier concentration dependence are in good agreement with reported values for silicon doped with shallow impurities such as boron.

Figure 4 shows the experimentally determined resistivity as a function of temperature for several different beryllium doping levels. The room-temperature resistivity and hole concentration are indicated for each curve. It is noted that the temperature at which zero TCR (i.e., the minimum in each curve) occurs can be selected from a wide temperature range by adjusting the beryllium doping level. For a room-temperature resistivity of about 1.0 ohm-cm, the TCR is approximately zero. At room temperature, 1.0-ohm-cm boron-doped silicon has a TCR of  $\approx 0.75\%/K$ . Shown in figure 4 is a  $T^{2.7}$  temperature dependence which would correspond to the variation of the resistivity of boron-doped silicon for doping levels below about  $5 \times 10^{16} \text{ cm}^{-3}$ , and for temperatures above about  $0^{\circ}\text{C}$ . (See ref. 7.)

## Piezoresistance

The experimental results presented herein are in terms of the longitudinal piezo-resistance gage factor which is given by

$$G_F = \frac{R(\epsilon) - R_0}{R_0 \epsilon} \quad (5)$$

where  $R(\epsilon)$  is the resistance under strain,  $R_0$  is the resistance for zero strain, and  $\epsilon$  is the strain along the gage axis. This is the customary sensitivity factor for strain gages and is exact if the resistance is linear with strain. The linearity of resistance with strain was examined for each sample tested. Essentially no deviations from linearity were observed for strains up to  $10^{-3}$  cm/cm. All gage factor measurements were taken at a strain of between  $4.5 \times 10^{-4}$  cm/cm to  $4.7 \times 10^{-4}$  cm/cm. Small changes in the strain level resulted from slight changes in the location of individual samples on the cantilever beam.

Figure 5 shows measured values of the piezoresistance gage factor taken at room temperature as a function of the sample resistivity for various crystal orientations. The solid lines and squares are reported data for boron-doped silicon. The solid lines (ref. 13) represent the highest gage factor reported in the literature for boron-doped silicon.

In general, the gage factor of beryllium-doped silicon is larger than for boron-doped silicon. Again, it must be pointed out that the data points represent conservative values, since the strain used in equation (5) is the theoretical strain at the surface of the deflected cantilever beam. By using the strain values obtained from a commercially available strain gage, the data points in figure 5 would be at least 10 percent higher.

The temperature dependence of the gage factor was measured for several gages. The data for five of the gages are shown in figure 6 and are representative of the temperature dependence of all the gages studied. The change in gage factor is approximately 30 percent per  $100^\circ$  C and the TCGF is only very slightly dependent on the doping level; this is also true for boron-doped silicon. (See ref. 1.) The solid curve in figure 6 represents the temperature dependence of gage factor in 1.0-ohm-cm boron-doped silicon and, for all practical purposes, is the same as that for the beryllium-doped gages.

## DISCUSSION

Two factors regarding the piezoresistance need to be discussed. First, the data in figure 5 indicate that the difference in the room-temperature piezoresistance gage

factor between beryllium-doped and boron-doped silicon is nearly independent of the doping level. Second, the data of figure 6 indicate that the temperature coefficient of piezoresistance gage factor for beryllium-doped silicon is almost the same as that of boron-doped silicon.

For small strains, the piezoresistance gage factor can be approximated as (ref. 2)

$$G_F = 1 + 2\nu - \frac{1}{\sigma} \frac{d\sigma}{d\epsilon} \quad (6)$$

where  $\nu$  is Poisson's ratio and  $\sigma$  is the conductivity, which in the strained state is

$$\sigma = q \sum_i \mu_i p_i \quad (7)$$

where  $\mu_i$  is the mobility and  $p_i$  is the concentration of the holes in the  $i$ th valence band. The conductivity can be written as

$$\sigma = q \mu_{\text{eff}} p \quad (8)$$

where

$$\mu_{\text{eff}} = \sum_i \mu_i \frac{p_i}{p} \quad (9)$$

and

$$p = \sum_i p_i$$

Thus,

$$G_F = 1 + 2\nu - \frac{1}{\mu_{\text{eff}}} \frac{d\mu_{\text{eff}}}{d\epsilon} - \frac{1}{p} \frac{dp}{d\epsilon} \quad (10)$$

The term  $\frac{1}{\mu_{\text{eff}}} \frac{d\mu_{\text{eff}}}{d\epsilon}$  is, to first order in the strain, the influence on the gage factor due to band edge changes with strain alone. Thus,

$$G_F = G_F^{(0)} - \frac{1}{p} \frac{dp}{d\epsilon} \quad (11)$$

Here  $G_F^{(0)}$  is the gage factor due to band changes and would be the gage factor of

boron-doped silicon in the temperature range where all the boron centers are ionized and, thus, cannot change the hole concentration with strain.

Now, the hole concentration under strain can be written

$$p = p_0 \exp\left(-\frac{\Delta E_f - \Delta E_{V,\text{eff}}}{kT}\right) \quad (12)$$

where  $\Delta E_f$  is the change in the Fermi energy with strain,  $p_0$  is the unstrained hole concentration, and  $\Delta E_{V,\text{eff}}$  is an effective shift in the valence band edge with strain given by

$$\frac{\Delta E_{V,\text{eff}}}{kT} = \ln \left[ \sum_i \frac{N_{Vi}}{N_V} \exp\left(\frac{\Delta E_{Vi}}{kT}\right) \right] \quad (13)$$

Here  $\Delta E_{Vi}$  is the shift of the individual band edges with strain. Equation (12) assumes no changes in the effective masses of the individual bands with strain. (See ref. 14.) At small strains, the shifts in the energy levels are taken to be of first order in the strain, (ref. 14) so that for small strains

$$\frac{1}{p} \frac{dp}{d\epsilon} = -\frac{\Delta_f - \Delta_{V,\text{eff}}}{kT} \quad (14)$$

where  $\Delta_f$  and  $\Delta_{V,\text{eff}}$  are "deformation potentials," which satisfy

$$\left. \begin{aligned} \Delta E_f &= \Delta_f \epsilon \\ \Delta E_{V,\text{eff}} &= \Delta_{V,\text{eff}} \epsilon \end{aligned} \right\} \quad (15)$$

The hole concentration can also be written as

$$p = f N_{\text{Be}} = \frac{N_{\text{Be}}}{1 + \exp\left(\frac{E_{\text{Be}} - E_f}{kT}\right)} \quad (16)$$

where  $f$  is the Fermi probability function,  $N_{\text{Be}}$  is the beryllium concentration,  $E_{\text{Be}}$  is the beryllium activation energy, and  $E_f$  is the Fermi energy. Differentiating equation (16) with respect to  $\epsilon$  and using equations (15) gives another expression for  $\frac{1}{p} \frac{dp}{d\epsilon}$  as follows:

$$\frac{1}{p} \frac{dp}{d\epsilon} = -(1 - f) \frac{\Delta_{\text{Be}} - \Delta_f}{kT} \quad (17)$$

Combining equations (17) and (14) to eliminate  $\Delta_f$  gives

$$\frac{1}{p} \frac{dp}{d\epsilon} = -\frac{1 - f}{2 - f} \frac{\Delta_{\text{Be}} - \Delta_{V,\text{eff}}}{kT} \quad (18)$$

Thus, the piezoresistance gage factor of beryllium-doped silicon is

$$G_F = G_F^{(0)} + \frac{1 - f}{2 - f} \frac{\Delta_{\text{Be}} - \Delta_{V,\text{eff}}}{kT} \quad (19)$$

An estimate of the change in the beryllium energy level due to strain  $\Delta_{\text{Be}}$  can be made from the data presented so far. At 400° C for the lightly doped samples  $p = N_A + N_{\text{Be}} \approx N_{\text{Be}}$ . Thus for the 4.34-ohm-cm samples,  $N_{\text{Be}} \approx 4 \times 10^{15} \text{ cm}^{-3}$ , and at room temperature  $f \approx 0.8$ . Also  $G_F - G_F^{(0)} \approx 20$  in the [111] direction. Thus,

$$\frac{\Delta_{\text{Be}} - \Delta_{V,\text{eff}}}{kT} \approx 120$$

Using data given by Wortman et al. (ref. 14) gives  $\Delta_{V,\text{eff}} = -3.3 \text{ eV/unit strain}$ . Then  $\Delta_{\text{Be}} \approx -0.2 \text{ eV/unit strain}$ . It should be pointed out that this calculation assumes that the beryllium energy level does not "split" with strain, but only shifts in energy.

#### CONCLUDING REMARKS

Beryllium-doped silicon strain gages were made which had a zero temperature coefficient of resistance at room temperature. The temperature at which zero temperature coefficient of resistance occurs can be adjusted over a considerable range above and below room temperature by adjusting the beryllium concentration. The beryllium-doped gages have slightly higher gage factors, lower temperature coefficients of resistance and comparable temperature coefficients of gage factor than the standard boron-doped silicon gages. The results imply that similar properties may be obtained by doping with other "deep" impurities such as indium whose ionization energy in silicon is 0.16 eV.

Langley Research Center,  
National Aeronautics and Space Administration,  
Hampton, Va., February 21, 1974.

## REFERENCES

1. Gross, Chris: A Radiation Method of Improving the Temperature Characteristics of Silicon Semiconductor Strain Gages. 22nd Annual ISA Conference Proceedings, Vol. 22, Pt. II, Preprint No. P22-1-PHYMMID-67.
2. Littlejohn, M. A.; and Gross, C.: Orientation Dependence of the Gage Factor in Electron-Irradiated Silicon. ISA Trans., vol. 9, no. 2, 1970, pp. 126-132.
3. Littlejohn, M. A.; and Loggins, C. D., Jr.: Influence of Oxygen-Vacancy Complex (A Center) on Piezoresistance of n-Type Silicon. J. Appl. Phys., vol. 43, no. 3, Mar. 1972, pp. 1074-1085.
4. Robertson, James B.: Effect of Beryllium on Oxygen in Silicon. Bull. Amer. Phys. Soc., ser. II, vol. 13, no. 11, Nov. 1, 1968, p. 1475.
5. Robertson, J. B.; and Franks, R. K.: Beryllium as an Acceptor in Silicon. Solid State Commun., vol. 6, 1968, pp. 825-826.
6. Crouch, Roger K.; Robertson, James B.; and Gilmer, T. E., Jr.: Study of Beryllium and Beryllium-Lithium Complexes in Single-Crystal Silicon. Phys. Rev. B, third ser., vol. 5, no. 8, Apr. 15, 1972, pp. 3111-3119.
7. Sze, S. M.: Physics of Semiconductor Devices. John Wiley & Sons, Inc., c.1969.
8. Ballard, L. F.; and Wortman, J. J.: Piezoresistance in Organometallic Crystals. J. Appl. Phys., vol. 41, no. 10, Sept. 1970, pp. 4232-4236.
9. Gwyn, C. W.; Scharfetter, D. L.; and Wirth, J. L.: The Analysis of Radiation Effects in Semiconductor Junction Devices. IEEE Trans. Nucl. Sci., vol. NS-14, no. 6, Dec. 1967, pp. 153-169.
10. Backenstoss, Gerhard: Conductivity Mobilities of Electrons and Holes in Heavily Doped Silicon. Phys. Rev., second ser., vol. 108, no. 6, Dec. 15, 1957, pp. 1416-1419.
11. Prior, A. C.: The Field-Dependence of Carrier Mobility in Silicon and Germanium. J. Phys. & Chem. Solids, vol. 12, no. 2, Jan. 1960, pp. 175-180.
12. Prince, M. B.: Drift Mobilities in Semiconductors. II. Silicon. Phys. Rev., vol. 93, no. 6, Mar. 15, 1954, pp. 1204-1206.
13. Sanchez, J. C.; and Wright, W. V.: Recent Developments in Flexible Silicon Strain Gages. Semiconductor and Conventional Strain Gages, Mills Dean III, ed., Academic Press, 1962, pp. 307-345.
14. Wortman, J. J.; Hauser, J. R.; and Burger, R. M.: Effect of Mechanical Stress on p-n Junction Device Characteristics. J. Appl. Phys., vol. 35, no. 7, July 1964, pp. 2122-2131.

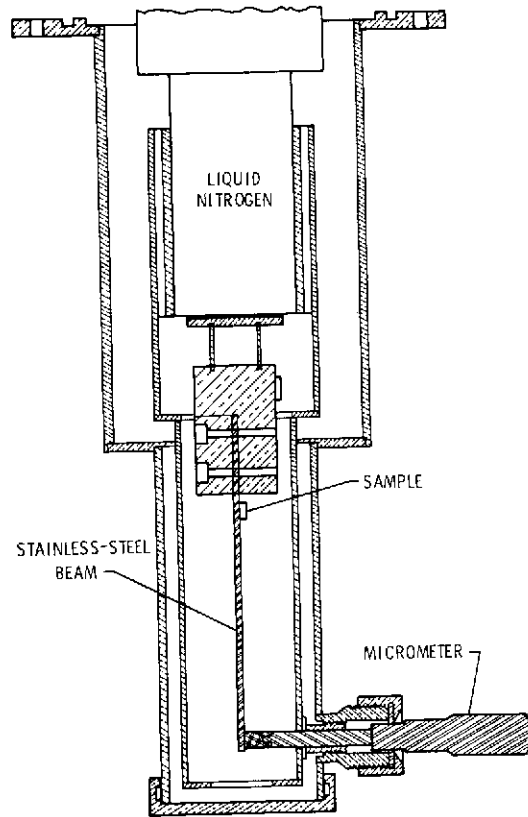

Figure 1.- Schematic of bottom section of cryostat used to take piezoresistance and resistivity measurements.

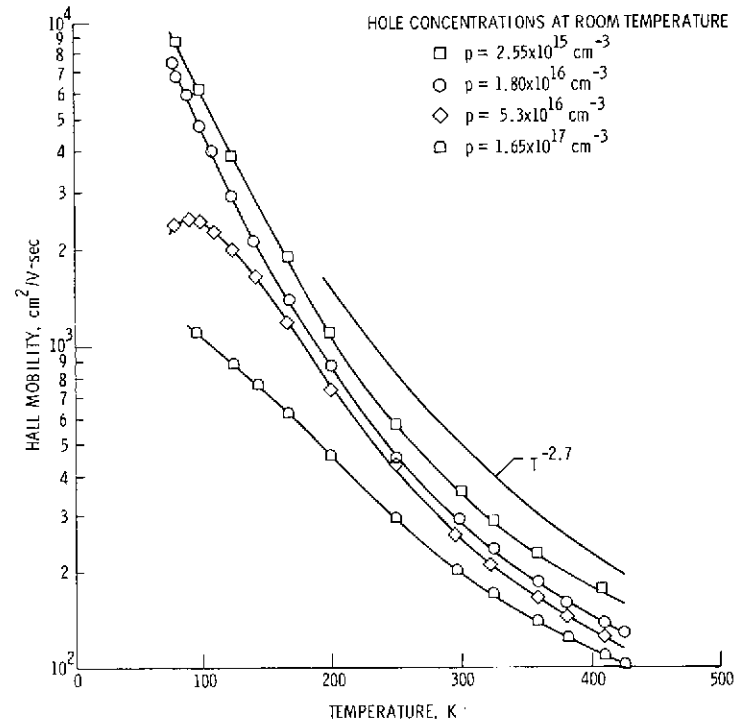

Figure 2.- Hall mobility as a function of temperature for beryllium-doped silicon.

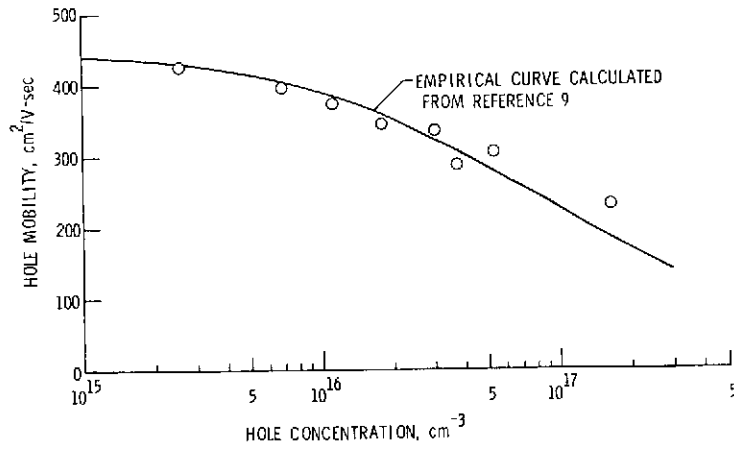

Figure 3.- Hole mobility as a function of hole concentration for beryllium-doped silicon.

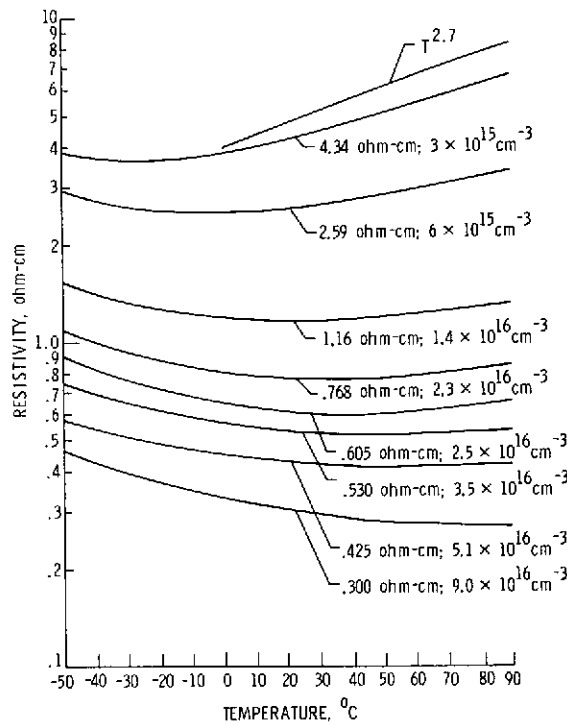

Figure 4.- Resistivity as a function of temperature for beryllium-doped silicon mounted on beam. Numbers given with each curve represent: room-temperature resistivity; room-temperature carrier concentration.



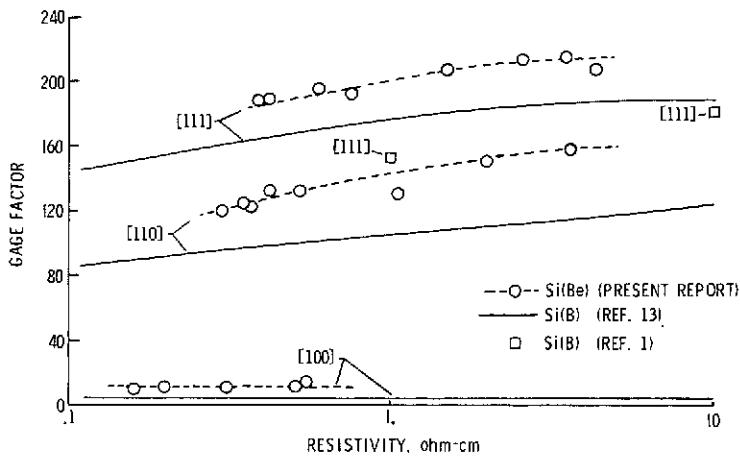

Figure 5.- Room-temperature piezoresistance gage factor as a function of resistivity for beryllium-doped silicon and boron-doped silicon.

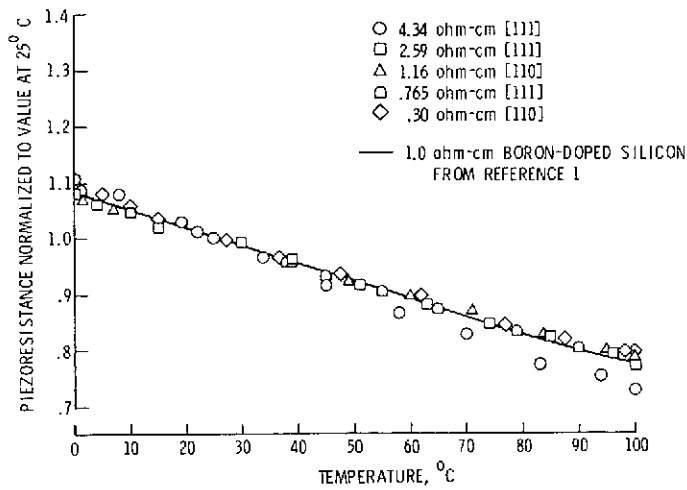

Figure 6.- Normalized piezoresistance gage factor as a function of temperature for beryllium-doped silicon.