

Potential Industrial Application

NASA SP-5918(02)

# CASE FILE COPY



**Welding  
Technology**

National  
Aeronautics  
And  
Space  
Administration

Small  
Business  
Administration

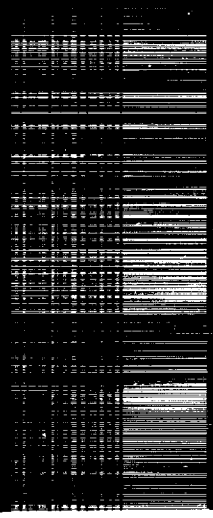



---

## FOREWORD

It is possible that your company's economic growth can be increased through the use of new and improved materials, equipment, and techniques developed by the aerospace industry. The results of the research and development efforts can assist you in achieving lower unit costs, an improved competitive position, developing new products, and increasing the profits of your business. By assisting you in realizing these goals, NASA's and SBA's Technology Utilization Programs are helping to apply the results of the aerospace industry's research and development activities. Thus, the public earns an increased return on their investment in the space effort.

Additional technical information on the material presented can be requested by circling the appropriate number on the Reader Service Card which is included in this compilation.

Unless otherwise stated, neither NASA nor SBA contemplates any patent action on the technology described.

**NOTICE** This document was prepared under the sponsorship of the National Aeronautics and Space Administration. Neither the United States Government nor any person acting on behalf of the United States Government assumes any liability resulting from the use of the information contained in this document, or warrants that such use will be free from privately owned rights.

---

For sale by the National Technical Information Service, Springfield, Virginia 22151. \$1.00

## TABLE OF CONTENTS

### SECTION 1. WELDING WITH AN ELECTRON BEAM

### SECTION 2. WELDING TECHNOLOGY SPECIAL ALLOYS

	Page		Page
Electron Beam Welder X-Rays its Own Welds . . . . .	1	Plastic Shield Prevents Oxide Formation on Hastelloy-X Weld Deposits . . . . .	13
Welding Cast Stellite 21 Turbine Blades to Cast Hastelloy-C Rings . . . . .	2	Weld Mechanical Properties of Furnace Brazed Inconel-718 . . . . .	15
Electron Beam Seals Outer Surfaces of Porous Bodies . . . . .	3	Flash Butt Welding of 6061 (T6) Stainless Steel for High Pressure Lines . . . . .	16
Mechanical properties of Electron Beam Welds in 3/8-in.-Thick Hastelloy-C . . . . .	4	Furnace Brazing of Inconel X-750, TIG-Welded with Inconel-718 Filler Metal . . . . .	17
Electron Beam Welding of Bimetal Tubing . . . . .	5	Weld Efficiencies of Inconel-TIG Welds Within Controlled Temperature Ranges . . . . .	18
Joining 304L Stainless Steel and NARloy Using an Inter- mediate Material . . . . .	5	Effects of High Frequency Current in Welding 6061 Aluminum Alloy . . . . .	19
Vacuum Chamber for Electron Beam Welding of Large Workpieces: A Concept . . . . .	6	Pre-Weld Heat Treatment Improves Welds in René 41 . . . . .	20
Filler-Wire Positioner for Electron Beam Welding . . . . .	7	Program Attains Quality Welds in Thick Tube Sections of Hastelloy-X . . . . .	21
Electron Beam Welding of Copper- Monel Aided by Circular Magnetic Shields . . . . .	8	Effect of Welding Position on Porosity Formation in Aluminum Alloy Welds . . . . .	21
Suppressor Plate Eliminates Undesired Arcing During Electron Beam Welding . . . . .	9	Complex Stainless Steel Assembly Braze by Ultrasonics without Flux . . . . .	23
Improved Electron Beam Welding Technique . . . . .	10		

---

SECTION 3. WELDING SHOP  
TECHNIQUES AND EQUIPMENT

---

	Page
Inconel-718 Replaces Inconel-69 as Filler Wire in Welding Inconel X-750 .....	25
Study of Weld Metal and Parent Metal Cracking in 347 Stainless Steel .....	26
Deep Penetration Welds for High Stress Applications .....	28
Water-Cooled Heat Sink Tool for Tube Welding .....	29
Butt Welder for Fine-Gage Wire .....	30
Spinarc Gas Tungsten Arc Torch Holder .....	32
Portable Machine Welding Head Automatically Controls Arc .....	33
Closed Circuit TV System Monitors Welding Operations .....	33
Flexible Drive Allows Blind Welding in Hard-to-Reach Areas .....	34
Automatic Reel Controls Filler Wire in Welding Machines .....	35
Mechanical Shielding Reduces Weld Surface Cracking in 6061-T6 Aluminum .....	36



## SECTION 1. WELDING WITH AN ELECTRON BEAM

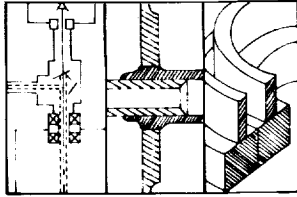

### ELECTRON BEAM WELDER X-RAYS ITS OWN WELDS

This technique uses the ray from an electron beam welder to X-ray its own welds. It provides the operator with a rapid check of weld quality without removing the workpiece from the vacuum chamber. A tungsten target "bounces" X-rays when hit by the electron beam and is so oriented that these X-rays are passed through the weld specimen onto Polaroid film.

A weld specimen is placed in a fixture, as shown, in the vacuum chamber of the welder. Polaroid film is placed immediately behind the specimen, backed with a lead sheet. When the beam is directed at the tungsten target in the chamber, X-rays are generated and pass through the weld and expose the film. The film can be developed in 10 seconds after removal from the vacuum chamber.

#### Note:

Once weld settings and positions have been determined, the rest of the run can be

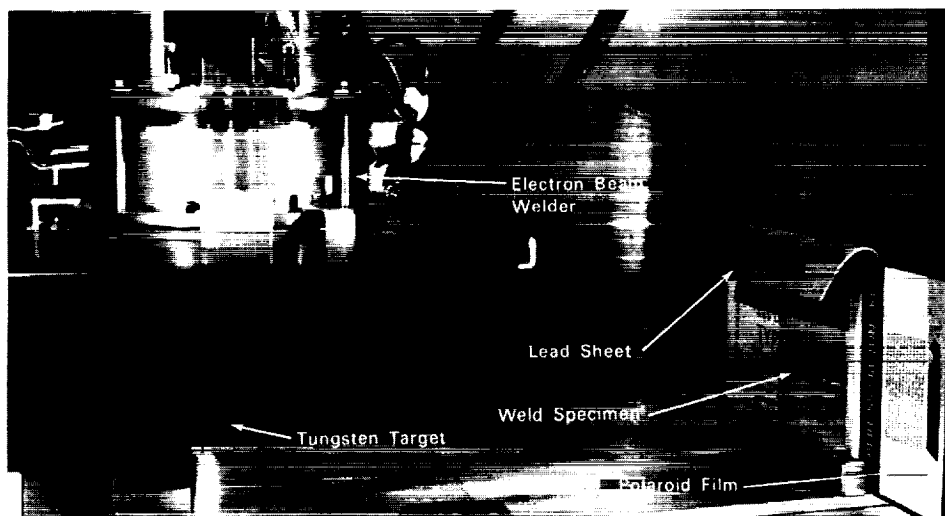

finished with a high degree of assurance that quality will match that of the sample.

Source: W. A. Roden of  
General Dynamics/Convair Division  
under contract to  
Lewis Research Center  
(LEW-10111)

*Circle 1 on Reader Service Card.*

### WELDING CAST STELLITE 21 TURBINE BLADES TO CAST HASTELLOY-C RINGS

Fillerless fusion electron beam welding has been used successfully to join cast stellite 21 and cast Hastelloy-C in the assembly of high speed turbine blade assemblies.

To determine whether operation at service temperature would generate detrimental conditions within the weld, one weldment was heated to 1400°F for 4 hours in air. Metallographic examination of both an as-welded and a heat treated weld revealed that no significant change had occurred other than a modest aging effect. Figure 1 shows a cross section of a single electron beam weld joint. As shown in Figure 2, the hardness of both alloys and the weld increased approximately 4 points Rockwell-C. The data also indicated that the mechanical properties of the weld and weldment would be equivalent to Hastelloy-C (cast) properties.

Source: R. E. Fish and C. S. Shira of  
North American Rockwell Corp.  
under contract to  
Marshall Space Flight Center  
(MFS-18960)

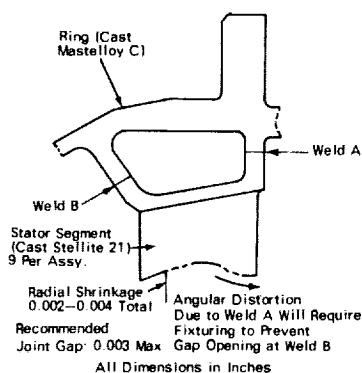

Figure 1. Illustration of Cross-Section of Electron Beam Weld Joint.

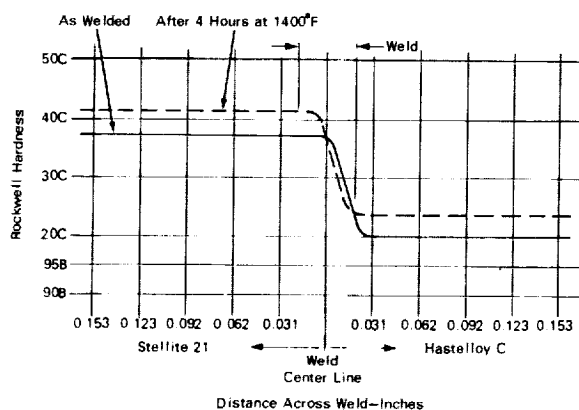

Figure 2. Hardness of Electron Beam Weld—Cast Stellite 21 to Cast Hastelloy C

*Circle 2 on Reader Service Card.*



## ELECTRON BEAM SEALS OUTER SURFACES OF POROUS BODIES

Porous tungsten plugs have had their outer cylindrical surfaces sealed by an electron beam process to ensure unidirectional air flow through their exit ends in an air bearing-supported gyro application. This avoids the introduction of lateral air flow, which would create turbulence that would degrade gyro reliability.

In this method, tungsten powder is compacted into rod form by the application of pressure, cut into plugs and then sintered and machined. Each plug is then placed in an electron beam welder and the beam is oscillated at an appropriate frequency as the workpiece is rotated and passed beneath the beam. The electron beam causes the high points of the tungsten surface to melt and the movement of the workpiece is such that a solid skin surface approximately 0.001 inch thick is achieved.

In the process outlined, voltages of about 105 to 110 kv and currents of about 1.5 ma are used. Workpieces are rotated at 20 rpm and linear movement is at 1 inch per minute. Source to specimen distance of from 5 to 8 inches is satisfactory. This invention would be useful in the areas of fluid and gas filters and metering devices.

Title to this invention has been waived under the provisions of the National Aeronautics and Space Act (42 U.S.C. 2457(f)), to the Kulite Tungsten Company, 1040 Hoyt Avenue, Ridgefield, New Jersey.

Source: Ronald A. Kurtz,  
Anthony D. Kurtz, and William H. Herz of  
Kulite Tungsten Company  
under contract to  
Marshall Space Flight Center  
(MFS-562)

*No further documentation is available.*

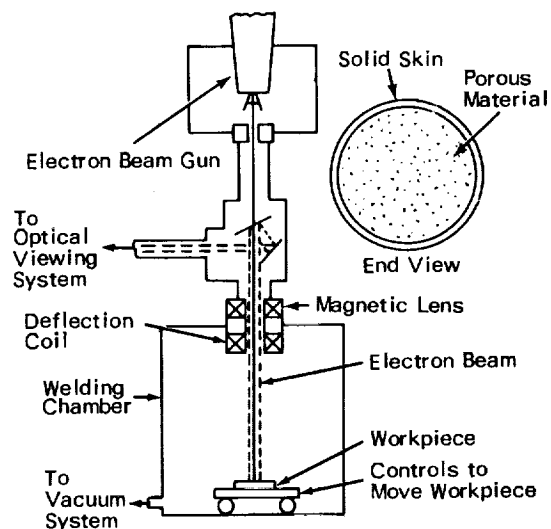

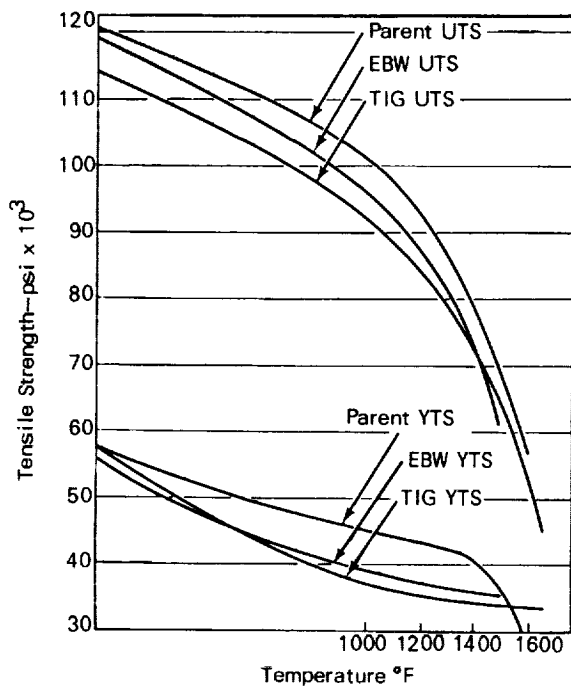

Figure 1



Figure 2

### MECHANICAL PROPERTIES OF ELECTRON BEAM WELDS IN 3/8-IN.-THICK HASTELLOY-C

Typical mechanical properties of electron beam (EB) welds in 3/8-in.-thick Hastelloy have been above the guaranteed minimum properties for the parent metal. Yield tensile strength (0.2% offset), ultimate tensile strength, and percent elongation in 0.5-, 1.0-, and 2.0-in. gage lengths of Hastelloy-C, tested at room temperature, 1000°, 1250°, and 1500°F in air were recorded. Figure 1 shows the electron beam weld properties in yield tensile strength (YTS) and ultimate tensile strength (UTS) to be similar to typical tungsten inert gas (TIG) weld and parent metal properties.

It was noted during the tests that elongation of the EB welds was significantly reduced in the 1000°F range. This is shown clearly in Figure 2. At room temperature and at 1250°F the major strain and fracture had occurred in the parent metal, while in the 1000° and 1500°F ranges these phenomena were observed in the weld. Based upon the supposition that the EB had caused, by preferential evaporation, variations in the chemical composition of the weld zone, a complete elemental analysis on both all-weld and all-parent metal zones indicated no significant differences.

Source: R. E. Fish and C. S. Shira of North American Rockwell Corp. under contract to Marshall Space Flight Center (MFS-19007)

Circle 3 on Reader Service Card.

## ELECTRON BEAM WELDING OF BIMETAL TUBING

An electron beam welding technique, requiring no metal filler, has minimized the heat-affected weld zone and produced a sound weld, completely fused and free from cracks and open defects in joining a stainless steel flange and bimetallic tube. The weld had to be compatible with a sodium-potassium (NaK) environment and had to be made in close proximity to a bimetallic bond between stainless steel and tantalum. It was not permissible to impair the metallurgical bond between the two materials by the welding heat.

A land area wider than the flange was machined from the stainless steel cladding of the bimetallic tube. The stainless steel flange was then fitted over the machined land area of the tube. The unit was then placed in a rotary fixture inside a vacuum chamber for electron beam welding. The vacuum level was maintained at  $1 \times 10^{-5}$  torr or better and the beam power level at 4.5 kW. The seam welding at the flange was done at a speed of 35 inches per minute. The flange thickness of one-half inch required one pass of the collimated beam.

Ultrasonic inspection techniques verified the bimetallic tube metallurgical bond integrity, and radiographic and fluorescent dye techniques verified the weld integrity.

Source: D. W. Medwid and G. Tulisiak  
Lewis Research Center  
(LEW-11554)

*No further documentation is available.*

## JOINING 304L STAINLESS STEEL AND NARloy USING AN INTERMEDIATE MATERIAL

An intermediate material has been successfully used to prevent the conventional cracking that has resulted when 304L stainless steel

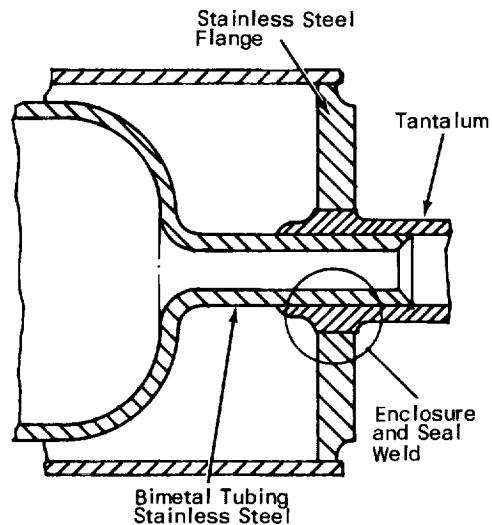

was electron beam welded to NARloy. An alloy of 90Ag-10Pd was used. The 304L stainless steel component was covered with a mold cast of the lower melting 90Ag-10Pd in a hydrogen atmosphere. This provided a brazed joint 304L stainless steel-to-90Ag-10Pd and a 90Ag-10Pd face. The 90Ag-10Pd-to-NARloy interface was then electron beam welded. Room temperature tests showed the intermediate material and weldment to be stronger than the NARloy base material.

Source: R. E. Fish and P. R. Winans of  
North American Rockwell Corp.  
under contract to  
Marshall Space Flight Center  
(MFS-19090)

*Circle 4 on Reader Service Card.*

#### VACUUM CHAMBER FOR ELECTRON BEAM WELDING OF LARGE WORKPIECES: A CONCEPT

In this concept, the item to be welded (cylinder, cube, sphere, etc.) is converted into its own vacuum chamber for the electron beam welding operation. This eliminates the need for "outsized" vacuum chambers which are expensive to construct and to operate and are infrequently used to their potential.

An external channel, with an elastomer seal, is placed around the two ring sections. This forms the outer vacuum seal around the weld butt. End plates with elastomer seals are then applied to each of the rings—these plates complete the forming of a chamber which can then be evacuated to at least 1 psi, and filled with inert gas. One end plate contains a quartz viewing window; the other plate carries the electron beam gun, vacuum ports, etc. Note that in the illustrated application, the ring sections to be welded form a concave surface which renders the task of creating the outer vacuum seal relatively easy. A straight cylindrical surface would require a raised metal "tent" which cannot come in contact

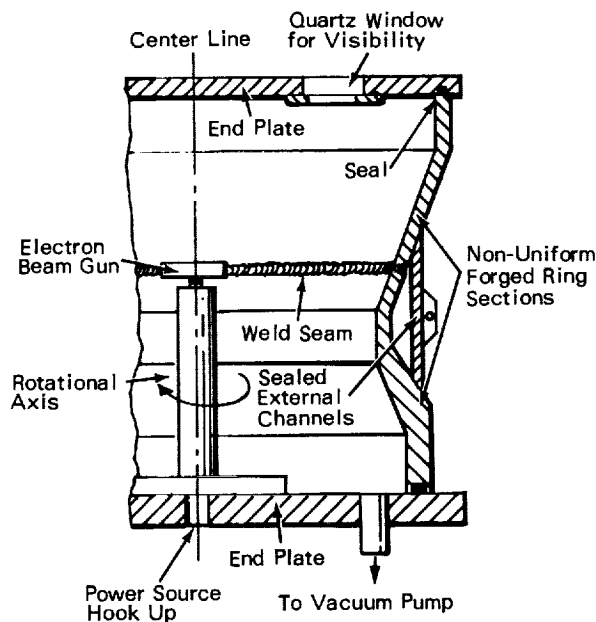

with the weld area, and which must have a sufficient span to eliminate the danger of heat affecting the elastomer seal.

Source: E. J. Tygard of  
Aerojet General Corp.  
under contract to  
Space Nuclear Systems Office  
(NUC-0059)

*No further documentation is available.*

### FILLER-WIRE POSITIONER FOR ELECTRON BEAM WELDING

This miniaturized filler-wire positioner is a time-saving, economical device which can be installed in an electron beam vacuum chamber for use with wire feed applications. Horizontal and vertical control of the positioner can be maintained from a console while the chamber is under vacuum. This prototype (see fig.) offers additional advantages over earlier

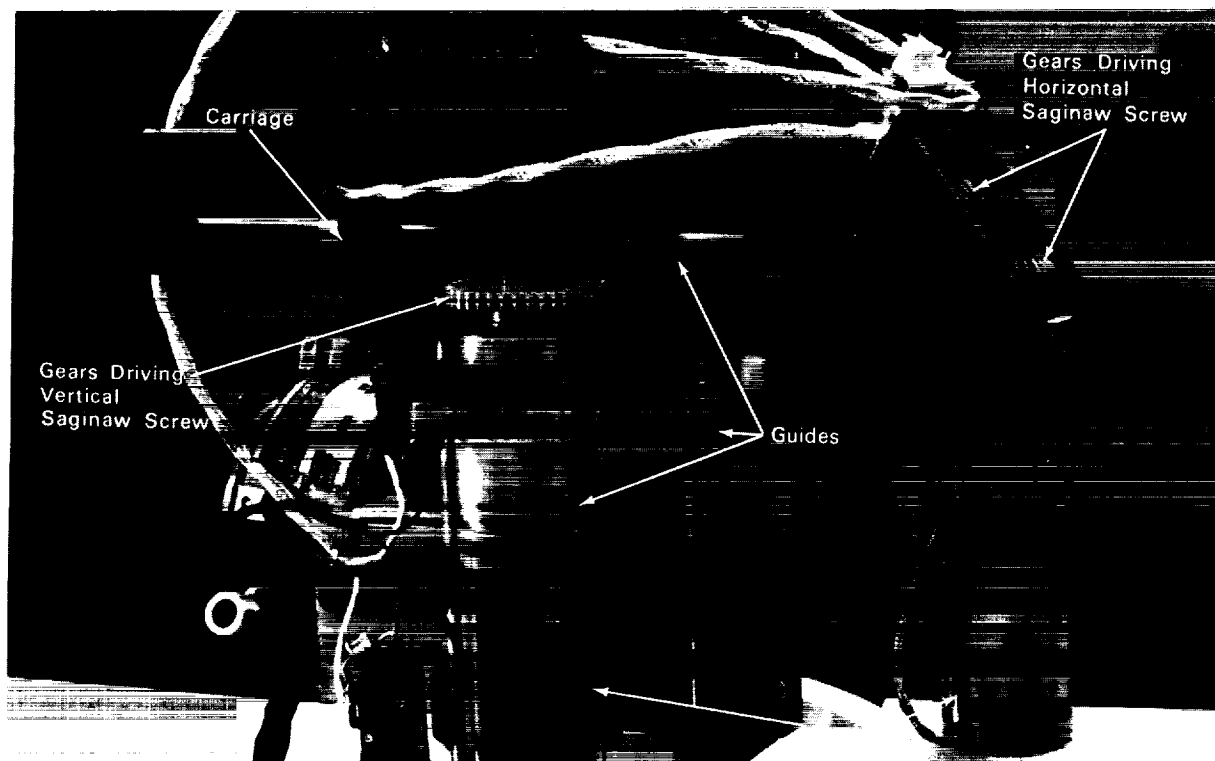

models in that the method of motor drive positioning of the wire feeder carriage is believed to be new; the small size of the entire unit offers additional vacuum chamber area; and the beam and wire feeder are independent of each other, enabling the wire to be removed from the beam area while still in a vacuum condition. Since prior devices were limited to a vertical plane only, more positive positioning of welding filler wire is achieved. This new unit may be installed in any hard-vacuum type electron beam welding machine.

The filler wire positioner contains two small 27-V dc motors which operate the carriage in both horizontal and vertical directions through gearing, low-friction type bearings, and Saginaw screws to obtain smooth, precise movement. A full wave rectified dc power supply furnishes the required variable voltage to run the motors from an operator's control panel. All electrical connectors are plug-in and the entire unit may be removed from the chamber when filler wire is not required in welding.

Source: W. M. Beaupre, J. A. Phillips, and  
L. B. Fueg of  
North American Rockwell Corp.  
under contract to  
Manned Spacecraft Center  
(MSC-15637)

*Circle 5 on Reader Service Card.*

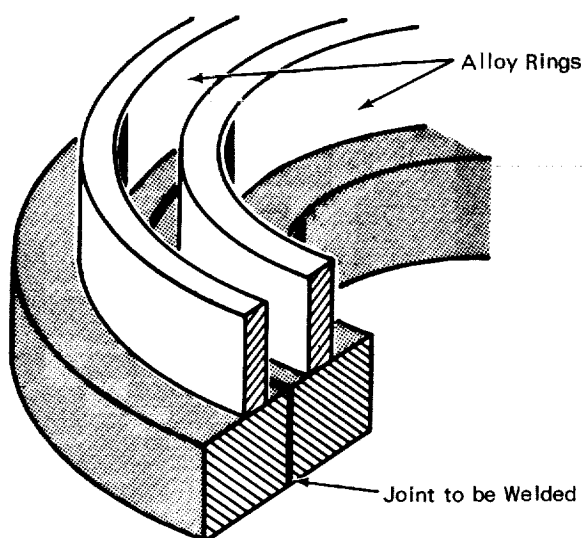

#### ELECTRON BEAM WELDING OF COPPER-MONEL AIDED BY CIRCULAR MAGNETIC SHIELDS

High permeability, soft magnetic rings placed on both sides of a circular weld seam provide a better means of making electron beam welds in a copper-monel circular joint. Previously, electron beams were deflected and mechanical adjustments were unsatisfactory.

In this technique, alloy sheet rings are fabricated out of two or three layers of 0.014-inch-thick highly permeable soft magnetic

material such as "Conetic-A" alloy. The resulting rings are about one inch high and 0.028-to 0.042-inch thick. The diameters are such that one ring can be placed inside the circular joint and one ring can be placed outside the joint.

The rings are placed adjacent to the joint to be welded and are not physically bonded in any way to the materials to be welded. The magnetic field seeks the high-permeability shield material, leaving a region of low magnetic force between the rings. The electron beam operates in this region and suffers no degradation due to magnetic deflection.

This simple shielding technique should find application in electron beam welding operations suffering from interactions between the beam and magnetic fields.

Source: J. N. Lamb of  
North American Aviation, Inc.  
under contract to  
Marshall Space Flight Center  
(MFS-569)

*Circle 6 on Reader Service Card.*

#### SUPPRESSOR PLATE ELIMINATES UNDESIRE ARCING DURING ELECTRON BEAM WELDING

A suppressor plate in the form of a grid at ground potential collects secondary emission

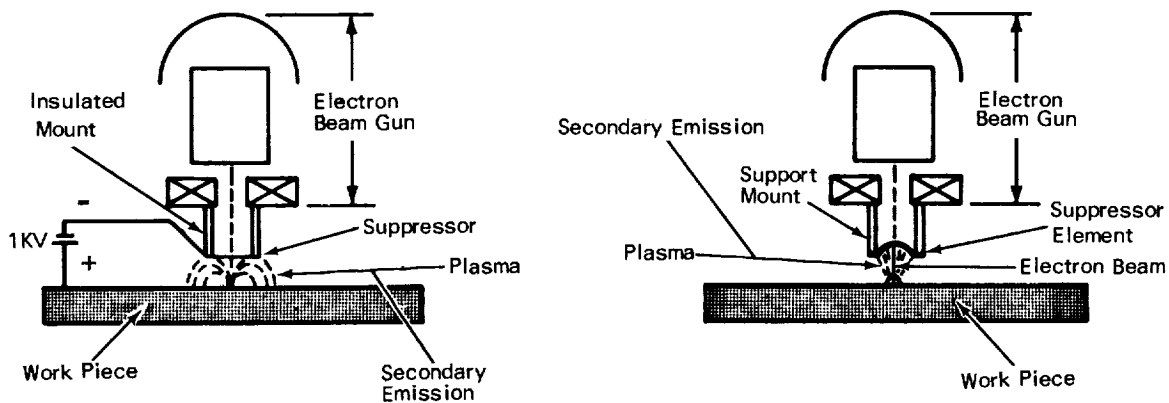

and prevents undesirable arcing during electron beam welding of 7000 series aluminum alloys.

An arc suppressor element, consisting of a suppressor plate and support tube, is connected to the bottom of the focus coil of the electron beam gun. The secondary emission of ions and electrons is collected on the suppressor plate which is mounted approximately 1/4-inch above the work, as shown on the right, or the suppressor plate may be supported by an insulated support tube and negatively energized, thus redirecting the secondary emission back to the work, as shown on the left. There is a notable increase in beam efficiency and the grounding screens covering the view ports are no longer needed.

Source: K. K. Handrey and  
J. C. Mahon of  
Marshall Space Flight Center and  
J. Kubick of  
Hayes International Corp.  
under contract to  
Marshall Space Flight Center  
(MFS-1126)

*Circle 7 on Reader Service Card.*

## IMPROVED ELECTRON BEAM WELDING TECHNIQUE

In electron beam welding, the projected beam and the workpiece are moved relative to each other to produce the welded joint. Either the beam is moved along a stationary workpiece or the workpiece is moved under a stationary beam. An electron beam, even of very high energy density, can penetrate the workpiece only a very short distance (on the order of several hundred microns). To produce a joint of appreciable penetration, the usual practice has been to maintain the beam at a sufficiently high energy density to vaporize material along the joint being welded. The beam then penetrates through the vapor and



produces a channel filled with vapor which becomes liquid and solidifies after the beam has moved to a succeeding position. A beam channel or hole is formed at the start of the welding seam and for this reason, the process has been called the "key-hole" process. The "key-hole" process has the disadvantages that it requires high beam energy and high energy density. The energy density must be sufficient not only to melt the material at the joint but also to vaporize it. While the power cost to achieve this high energy must be considered, a more important factor is that the high energy, which the incremental parts of the joint receive from the beam, produces imperfections in the weld by reason of variations in beam power and small inhomogeneities in the work. In fact, it has been realized that in order to produce high-quality welded seams, a delicate balance must be maintained between beam-power input and the melting vaporization rate of the work, i.e., welding speed.

The power density of the beam, relative to the speed of the workpiece, is such that the material is melted but not vaporized; thus, an inclined weld-front, shown in the figure, is produced. The angle of inclination of the

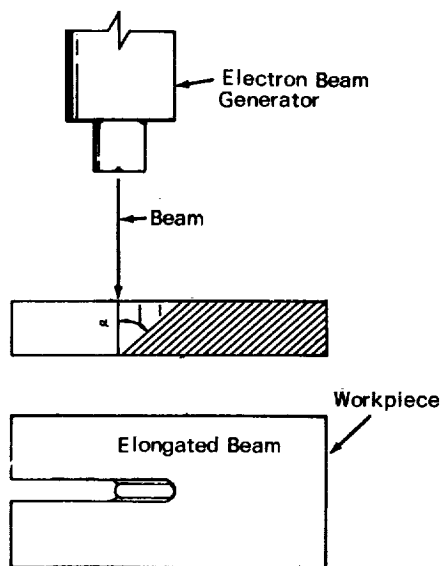

Formation of an Inclined Weld-Front with an Electron Beam

weld-front depends on the diameter of the beam on the workpiece and the desired depth or penetration of the weld (usually the depth is 100% penetration). At the start of a weld, there is slight vaporization of the workpiece and, at the end, the weld terminates in a sloped crater (if stopped before the end of the metal part is reached) or in a sloped notch. At successive regions of the melt-front, the liquid work material moves out of the path of the beam so that the beam progressively impinges on unmelted material.

The electron beam may also be swept back and forth along the direction of movement of the workpiece by applying an oscillatory voltage to the control coils. This produces, in effect, an elongated beam with a substantially higher angle of inclinations than for an axially symmetric beam.

Source: B. Schumacher of  
Westinghouse Electric Corp.  
under contract to  
Marshall Space Flight Center  
(MFS-20714)

*Circle 8 on Reader Service Card.*

## SECTION 2. WELDING TECHNOLOGY INVOLVING SPECIAL ALLOYS

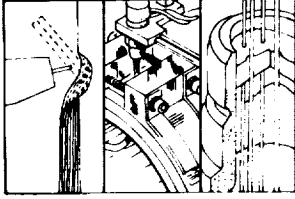

### PLASTIC SHIELD PREVENTS OXIDE FORMATION ON HASTELLOY-X WELD DEPOSITS

A protective shield has been coupled with an inert atmosphere over the weld deposit after the weld passes the torch nozzle, and prevents oxide formation on Hastelloy-X weld deposits.

This prevents contamination of Hastelloy-X tungsten-inert-gas (TIG) welds of the circumference of a cylindrical section. Oxides are formed on the weld deposits by atmospheric contamination which occurs in the solidifying, high temperature metal which has passed the electrode and inert gas blanket provided by the torch nozzle. Prevention of oxidation eliminates weld interpass cleaning and minimizes contamination and weld defects.

The protective shield consists of two inert atmosphere shield bands covering the weld area both on the inside and outside of the cylindrical section. The bands are made of transparent plexiglass and have teflon tape applied and positioned as shown in the sketch. The tape and plexiglass bands form an inert gas space over the weld deposit for the entire circumference. The inert gas is supplied to each band and flows around the entire circumference to escape at the band joints. The plexiglass bands are tightened sufficiently with outer band tightening bolts and inner band expansion bolts so that a gas-side seal is provided by the teflon tape. The teflon also provides a bearing surface with minimum frictional resistance so that the work, mounted and rotated by a power driven mandrel, moves between the Plexiglass band as the weld passes the TIG torch. Provision is made for the TIG torch nozzle at the top of the outer band. An

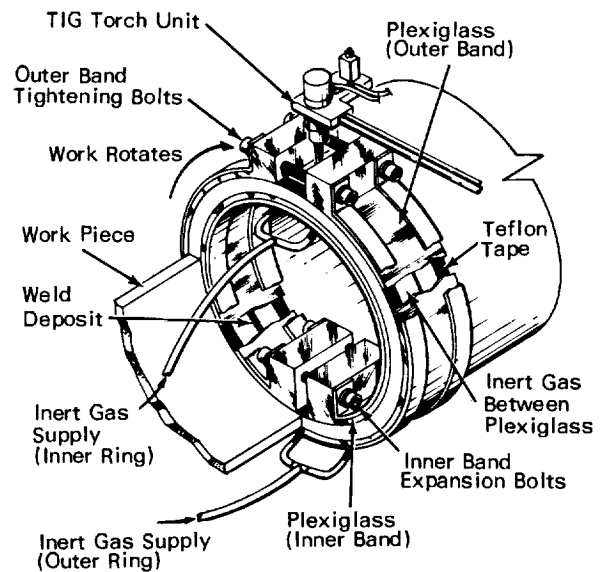

auxilliary support system (not shown) holds the bands in a stationary position while the work is rotated.

Source: C. W. Fletcher of  
Aerojet General Corp.  
under contract to  
Space Nuclear Systems Office  
(NUC-0066)

*No further documentation is available.*

#### WELD MECHANICAL PROPERTIES OF FURNACE BRAZED INCONEL-718

It was determined that furnace brazed Inconel-718 assemblies were critically stressed and an investigation was undertaken regarding the weld mechanical properties of the brazed joints to determine whether stress requirements could be met.

For the test, sufficient 1/4-in. thick Inconel 718 sheet material, heat number HT 6958 EV, was obtained to supply parent metal and weld metal specimens. Weld plates were automatically welded by the tungsten inert gas (TIG) process using 1/16-in. diameter Inconel 718 filler metal, heat number HT 5154 E. Four weld passes were required to fill the 90° included angle weld joint. Weld and parent metal tensile specimens were machined and subsequently exposed to the first and second braze cycles. Three specimens representing parent metal, weld metal (reinforcement left on) and weld metal (reinforcement machined off) were sent through the first braze cycle with T/C Unit 2014 and the second braze cycle with T/C Unit 020. The results of room temperature tensile tests are reported in the table. The weld efficiencies of weld metal

ROOM TEMPERATURE MECHANICAL PROPERTIES OF BRAZE CYCLED  
INCONEL 718, PARENT METAL AND WELD METAL SPECIMENS  
1/4" Thick Inconel 718 Sheet, HT 6958 EV  
1/16" Diameter Inconel 718 Filler Metal,  
HT 5154 E, TIG Welding Process

Bar No.	0.2% Yield Str. (KSI)	Ult. Tensile Str. (KSI)	% Elongation in			Fracture Location
			1/2"	1"	2"	
Parent Metal Specimens						
D-3	132.3	166.0	24	18	16	
D-34	130.2	165.2	24	20	18	
D-35	131.5	166.0	25	21	18	
	Avg. 131.3	165.7	24.3	19.7	17.3	
Welded Specimens, Weld Reinforcement On						
W-1-13	133.2	156.8	12	8	6	Weld
-14	136.0	155.2	12	8	7	Weld
-15	135.8	158.0	12	8	11	Weld
	Avg. 135.0	156.7	12	8	8	
Welded Specimens, Weld Reinforcement Off						
W-2-1	128.9	158.0	18	14	11	H.A.Z.
-14	124.2	156.2	20	15	12	H.A.Z.
-21	129.2	159.2	20	16	12	H.A.Z.
	Avg. 127.4	157.8	19.3	15	11.7	

Specimens exposed to the following braze cycles:

First Braze Cycle with U/N 2014

Second Braze Cycle with U/N 020

(reinforcement removed) to parent metal for the average properties reported were 97% and 95% for the 0.2% yield strength and ultimate tensile strength respectively. The minimum weld efficiencies, lowest reported weld metal strength to highest reported parent metal strength, were 94% for both the 0.2% yield and ultimate tensile strengths.

Source: R. E. Fish and R. D. Betts of  
North American Rockwell Corp.  
under contract to  
Marshall Space Flight Center  
(MFS-18945)

*No further documentation is available.*

## FLASH BUTT WELDING OF 6061(T6) STAINLESS STEEL FOR HIGH PRESSURE LINES

### SETTINGS FOR FLASH WELDED ALUMINUM PIPE

	5.75 in. O.D. Pipe	7.075 in. O.D. Pipe
Upset	7/8"	1-1/2"
Automatic Flash	1-1/2"	2"
Manual Flash	1/8"	1/8"
Initial Die Opening	2-1/2"	3-1/4"
Final Die Opening	0.0	0.0
Total Loss	2-1/2"	3-1/4"
Flashing Time	13.5 sec	20.1 sec
Voltage	11.4	14.5
Gas	None	None
Pre-Heat	None	None
Current After Upset Start	18 cycles	23 cycles
Post-Heat	None	None
Upset Speed Nut	12	12
Material	6061-T6	6061-T6
Final H.T.	Re-Age 340°F 8 hrs.	Re-Age 340°F 8 hrs.

The use of flash butt welding has been attempted in an effort to reduce costs below those associated with previously employed tungsten-inert gas (TIG) welding. The alloy used was 6061 in the T6 (aged) condition and the pipe sizes were 5.75-in. O.D. with a 0.325 in. wall thickness plus 7.875-in. O.D. with a 0.440-in. wall thickness. Five samples of each pipe size were welded using the settings shown in the table.

Testing of these pipe welds was divided into two parts. First an evaluation was made of mechanical properties and included tensile tests, fatigue tests, and tensile properties after repair. Tests performed were as follows:

- \*1. Notch and smooth tensile strength at room temperature and at -320°F.
2. Fatigue tests producing an S-N curve at room temperature.
3. Metallographic examination.
4. Smooth bar stress corrosion tests.

\*20 specimens were tested at room temperature to obtain a guaranteed minimum. In addition to the above tests, one pipe containing flanges was subjected to a 72-hour duration salt-spray test. Another flanged pipe was hydrostatically burst tested. The section subjected to salt spray suffered no pitting or serious corrosion.

Bars stressed to 75% of their 0.2% yield stress exhibited no stress corrosion cracking after 48 hours of alternate immersion testing, an interesting point in view of the unique joining process. The hydrostatic burst test (burst pressure at 5540 psi, within a few psi of the calculated) showed the weld to be as strong and ductile as the parent metal.

Source: J. N. Lamb of  
North American Rockwell Corp.  
under contract to  
Marshall Space Flight Center  
(MFS-18943)

Circle 9 on Reader Service Card.

### FURNACE BRAZING OF INCONEL X-750, TIG-WELDED WITH INCONEL-718 FILLER METAL

Use of Inconel 718 filler metal for joining Inconel X-750 components has found wide application, thus forcing establishment of statistically based guaranteed minimum property levels after exposure to the F-1 braze cycles. To establish these levels, ten tensile specimens were tested at room temperature, 400°, 800°, 1000°, 1200°, and 1400°F. These data were processed through a computer analysis (guaranteed minimums, 99% reliability and 95% confidence limits) and recorded. All data were reviewed with respect to tensile bar condition and stress/strain curve irregularities. Minor adjustments to the computer-calculated guaranteed minimum properties were made in the light of these observations and on the basis of engineering judgement commensurate with the behavior of nickel base age-hardenable alloys. These values, therefore, represent statistically sound property levels and should not be factored further if the total engineering capability of these materials is to be realized. The figure presents graphically the average mechanical properties and compares them to the guaranteed minimum mechanical properties for furnace braze cycled Inconel X-750 welded with Inconel 718 filler metal.

Source: R. D. Betts of  
North American Rockwell Corp.  
under contract to  
Marshall Space Flight Center  
(MFS-18918)

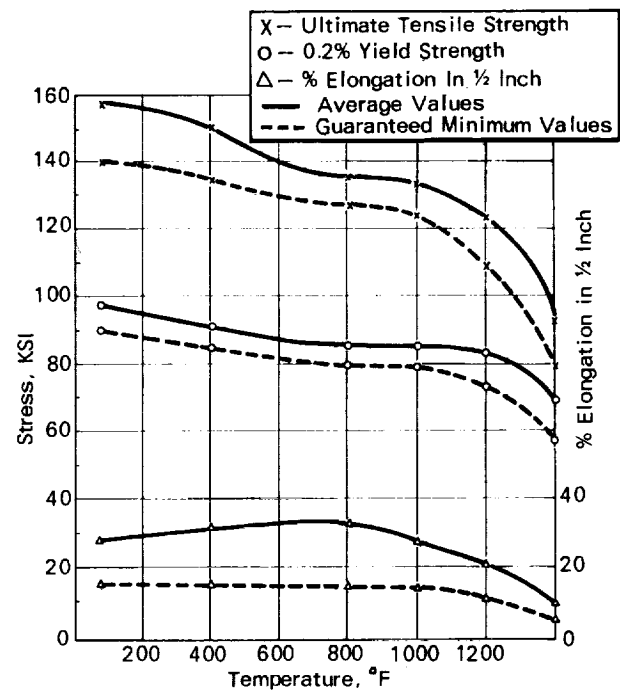

Average and Guaranteed Minimum Mechanical Properties of F-1 Braze Cycled Inconel X-750 Welded with Inconel 718 Filler Metal

*No further documentation is available.*

### WELD EFFICIENCIES OF INCONEL-TIG WELDS WITHIN CONTROLLED TEMPERATURE RANGES

Tests have been performed to obtain additional information concerning weld efficiencies of Inconel 718 TIG arc welds in the -423° to 1500°F temperature range. Inconel 718 1/4-in. thick plate was sheared into 3-in. wide strips that were then butt welded in pairs by the TIG process, using 1/16-in. diameter Inconel 718 filler metal. One set of weld tensile specimens was machined with the weld reinforcement left on while the others had the weld reinforcement removed flush with the parent metal. All specimens, weld metal and parent metal, were heat treated prior to testing.

The specimens were tested at -423°F, room temperature, 1000°F, 1200°F, and 1500°F. Ultimate tensile strength, 0.2% yield strength, and percent elongation in 2-in., 1-in., and 1/2-in. increments were determined and recorded. While parent metal tensile strengths did not meet specification minimum 0.2% yield strength (145,000 psi) in room temperature tests, all welds so tested proved well above specification minimum requirements. It is felt that a weld efficiency of 90% is a conservative but realistic value that can be applied to TIG Inconel 718 welds in the -423° to 1500°F temperature range.

Source: R. D. Betts of  
North American Rockwell Corp.  
under contract to  
Marshall Space Flight Center  
(MFS-18914)

*No further documentation is available.*



## EFFECTS OF HIGH FREQUENCY CURRENT IN WELDING 6061 ALUMINUM ALLOY

Cracking has been found to occur frequently in the heat-affected zone of aluminum alloy 6061 weldments during TIG (tungsten inert gas) ac welding. The cracks appeared to be intergranular separations, normal to overheated aluminum alloy. An ensuing investigation showed the cracks to be superficial surface defects, located only on the torch side of the weld in areas of grain boundary melting and seldom more than 0.015-in. deep. The cracking continued to occur even when the best known TIG welding procedures were employed and strict control was maintained.

Continuous observation during welding revealed that the cracks developed when improperly adjusted, or erratic, superimposed high frequency current was agitating the semi-molten metal in the areas of grain boundary. Lack of, or depletion of, boundary constituents combined with rapid freezing and normal shrinkage stresses (hot shortness) resulted in boundary voids or cracks.

A series of original tests was performed, which involved the heating of test plates to temperatures normal to the heat-affected zone and applying only high frequency current. The high frequency arc was varied by controlling arc length, electrode diameter, and the welding power supply for phase shift and intensity. Each plate was examined for surface defects immediately after testing and after 30 days.

An increase in the magnitude of any variable resulted in an increase in arc length or plate temperature and caused the most noticeable effect. After natural aging, severe crack propagation was found in areas exhibiting moderate boundary melting or a dendritic freezing pattern. The results were considered conclusive in demonstrating that uncontrolled

high frequency current alone was extremely deleterious to the finished weld.

Source: R. E. Fish of  
North American Rockwell Corp.  
under contract to  
Marshall Space Flight Center  
(MFS-18337)

*Circle 10 on Reader Service Card.*

#### PRE-WELD HEAT TREATMENT IMPROVES WELDS IN RENÉ 41

This heat treatment reduces the incidence of post-weld "strain age" cracking of René 41.

It was found that if, preliminary to welding, the René 41 was slowly (40°F/min) cooled from the solution-annealing temperature, the degree of "strainage" cracking could be reduced by 90 percent or more. The technique virtually ensures the absence of cracks perpendicular to the weld and will confine cracks to the vicinity of the fusion line, thus simplifying repairs. The treatment may conveniently be integrated with normal processing and, in many cases, simplifies heat-treating requirements (replaces a quenching operation). Slower cooling rates should be necessary for heats of very-low-carbon content (0.06 percent) to achieve a given degree of cracking reduction. The microstructure formed during the slow cooling rate tested (and slower ones) favors elevated-temperature ductility. Some vestiges of this microstructure are apparently retained during welding and thus enhance "strain-age" crack resistance in air.

The technique may be used for jet engine components of René 41 and should also apply for similar precipitation-hardenable nickel-base alloys such as Waspaloy, U500, etc.

Source: M. Prager of  
North American Rockwell Corp.  
under contract to  
Marshall Space Flight Center  
(MFS-18174)

*Circle 11 on Reader Service Card.*

## PROGRAM ATTAINS QUALITY WELDS IN THICK TUBE SECTIONS OF HASTELLOY-X

A welding program has been developed that produces premium quality, multipass welds in thick tube sections of Hastelloy-X.

The tube is rotated in a tilt table positioner beneath a stationary TIG semiautomatic weld torch. Welding amperage, voltage, wire feed rate, shielding gas flow, and rotational travel speeds are preset. Weld passes are deposited following an alternating ID/OD pass sequence to balance weld shrinkage forces and minimize distortion. The tube is tilted on its longitudinal axis, as required for each pass, to present the joint area being welded in a horizontal position relative to vertical alignment of torch, and to prevent lack of fusion caused by gravity flow of molten weld metal.

This procedure may be used to advantage in the welding of chemical equipment (autoclaves, flanges) and high-temperature processing facilities (furnace mufflers, grates, etc.).

Source: C. W. Fletcher, F. J. Flens, and  
L. F. Glasier, Jr. of  
Aerojet General  
under contract to  
AEC-NASA Space Nuclear Systems Office  
(NUC-10048)

*Circle 12 on Reader Service Card.*

## EFFECT OF WELDING POSITION ON POROSITY FORMATION IN ALUMINUM ALLOY WELDS

This program investigated the effects of varied welding positions on such weld qualities as deposit soundness and uniformity, bead geometry, chemical composition, and mechanical properties. Automatic MIG welds have been prepared in positions ranging from flat (0 degrees) to 35 degrees both upslope and downslope, using standing welding procedures such as weld speed in inches per minute, weld current and voltage, torch lead

angle, and shielding gas delivery rates.

Progressive changes in bead geometry occur as the weld plane angle is varied from 35° upslope to 35° downslope. Generally, upslope welds are characterized by a narrow weld deposit with a high crown, while downslope welds are wide and flat. The fused cross section area is found to be greater and to contain somewhat greater amounts of copper (from welding 2014-T6 aluminum alloy) in downslope welding, indicating that more of the parent plate is melted when welding in this plane. Nondestructive inspection indicates that fewer surface and internal defects are produced by welding upslope as opposed to downslope. Upslope welds made at 25° and 35° angles are completely free of defects. As the weld plane is reduced through the flat position to a 35° downslope angle, both surface and internal porosity become progressively more severe. The porosity content observed in all downslope welds are such that these will not meet acceptance specifications.

As shown in the figure, the gravitational effect on the weld puddle varies greatly with welding position. Porosity, forming in the weld puddle, rises vertically toward the surface where it is liberated in the form of gas.

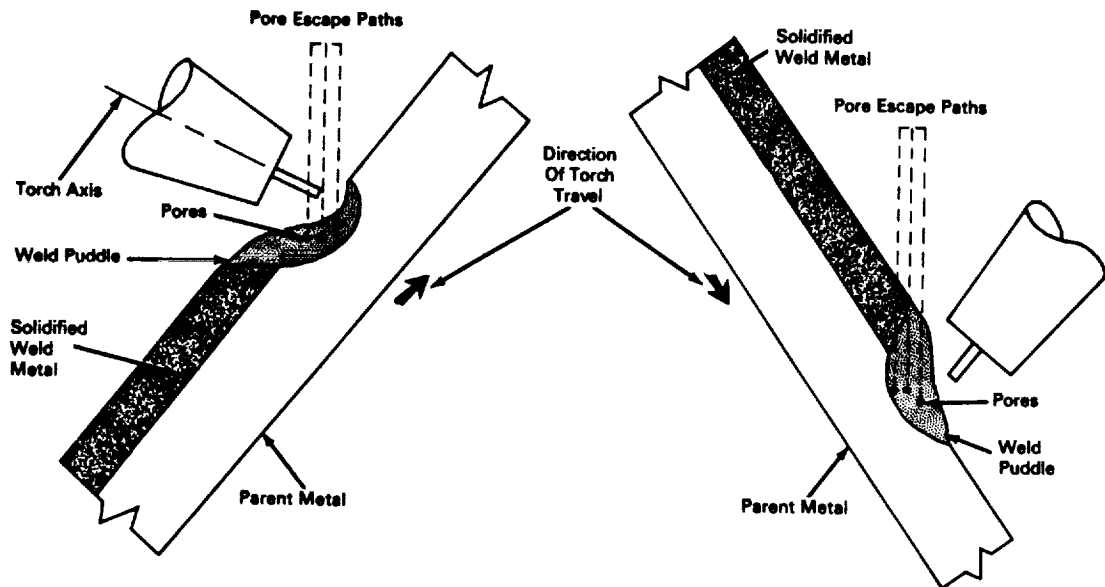

In the case of upslope welds, the escape path is quite short and essentially all porosity is liberated before the puddle solidifies. Downslope welds, however, present a much longer escape path and the weld puddle has a tendency to solidify before the gas bubbles can rise to the surface and they are entrapped in the weld deposit as porosity.

Source: R. S. Wroth and J. Haryung of  
Douglas Aircraft Company  
under contract to  
Marshall Space Flight Center  
(MFS-2318)

*Circle 13 on Reader Service Card.*

#### COMPLEX STAINLESS STEEL ASSEMBLY BRAZED BY ULTRASONICS WITHOUT FLUX

Vibration of an assembly with an ultrasonic transducer ensures that the brazing material will flow down the length of each stainless steel tube in contact with the seal plug without the use of flux.

The brazing operation utilizes an rf-inductively heated furnace with an inert environment. Prior to brazing, the seal plugs and tubes are thoroughly cleaned, and the face of the seal plug is oxidized (blued) before machining the tube holes through the plug. The oxidized surface acts as a dam to prevent the flow of the brazing material onto the seal plug face rather than into the holes. The brazing alloy for this application is ASTM B-260B AG-1 with 0.5% lithium. The transducer (octopus type-special design) is attached to the stainless steel tube assembly at a distance of 7 inches below the oxidized face of the seal block. (Seven inches is a multiple of 3 1/2 inches which is the wavelength of the 28 kc ultrasonic energy for stainless steel.) The brazing temperature is 1375°F. Clearance between the stainless steel tubes and the holes in the seal plug is approximately 5 mils.

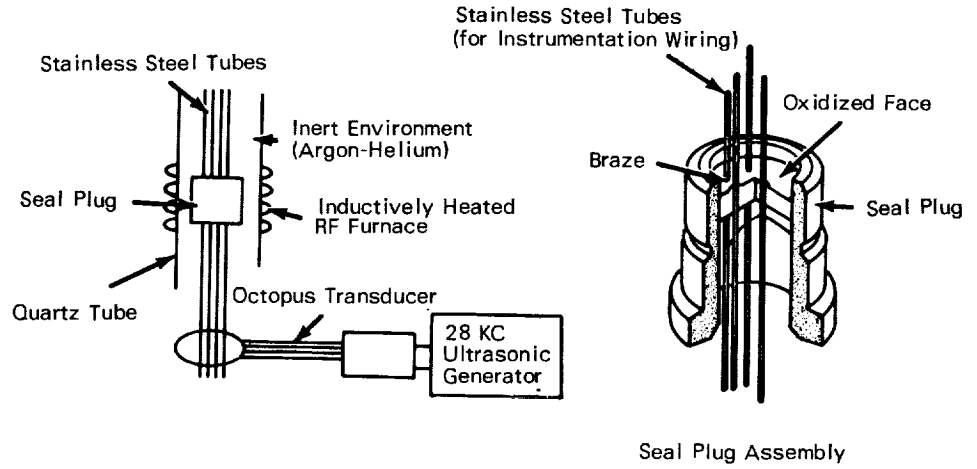

Source: W. H. Baker of  
Westinghouse Astronuclear Laboratory  
under contract to  
Space Nuclear Systems Office  
(NUC-0115)  
*Circle 14 on Reader Service Card.*

## SECTION 3. WELDING SHOP TECHNIQUES AND EQUIPMENT

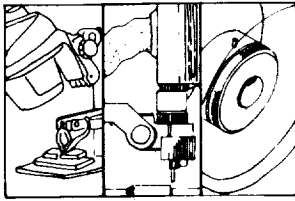

**INCONEL-718 REPLACES INCONEL-69  
AS FILLER WIRE IN WELDING  
INCONEL X-750**

Inconel 69 as the filler material has been used in the past to TIG weld Inconel X-750 components. It was felt that Inconel 718 could give superior results as a filler to join components of Inconel X-750 parent metal. To resolve this question, a series of tests (see table) was conducted using 1/4-inch Inconel X-750 plates (machined 45° double bevel with 0.040-in. lands) TIG butt welded with both Inconel 69 and Inconel 718 filler wire, the welds being back-ground after each welding pass to improve fusion quality.

As shown in the table, the tensile properties of the two welds were very closely matched. However, it has been determined by tests that welds using Inconel 718 as the filler material are much more tolerant of welding abuse than are those employing Inconel 69 as the filler material.

GUARANTEED MINIMUM AND AVERAGE ROOM TEMPERATURE PARENT METAL  
AND WELD METAL TENSILE PROPERTIES OF INCONEL X-750 WELDED  
WITH INCONEL 69 OR INCONEL 718 – SEVERAL SOURCES USED

METAL	ULTIMATE TENSILE STRENGTH (KSI)		0.2% YIELD STRENGTH (KSI)		% ELONGATION (AVE.) BY GAGE LENGTH		
	Ave.	G Min	Ave.	G Min	2"	1"	1/2"
Inconel 69 Filler	172.7	165.4	121.9	105.6	20.3	23.8	28.5
Inconel 718 Filler	171.6	165.5	120.1	109.8	20.4	23.9	29.3
Inconel X-750 Parent Metal	171.2		116.8		29.5	37.5	46.0

Source: D. J. Trimble, S. Nunez, and  
R. E. Fish of  
North American Rockwell Corp.  
under contract to  
Marshall Space Flight Center  
(MFS-18848)

*Circle 15 on Reader Service Card.*

#### STUDY OF WELD METAL AND PARENT METAL CRACKING IN 347 STAINLESS STEEL

This study was undertaken to determine the relationship of ferrite content and chemical composition of the weldability of 347 stainless steel and, more specifically, to determine the causes of periodic cracking in shop welding operations.

As control specimens, tensile coupons were made from parent materials containing zero % ferrite and 6% ferrite, respectively. These specimens were tested in conjunction with three different filler materials, 6% ferrite filler, 312 filler, and Hastelloy-W filler. The specimens (including parent metal and filler materials) were cycled from room temperature to -320°F 20 times during the test, or not cycled. Results of the tests are shown in the Figures with Figure 1 showing the ultimate strength and 0.2% offset yield strength for both low temperature cycled specimens and those not low temperature cycled. Figure 2 shows the percent elongation of the same specimens, cycled or not cycled, at 1/2-in. and 1-in. gage marks.

After each five cycles of the 20 room-temperature to -320° cycles, a dye penetrant inspection was performed to check for cracks. The six percent ferrite parent material (HT#M6



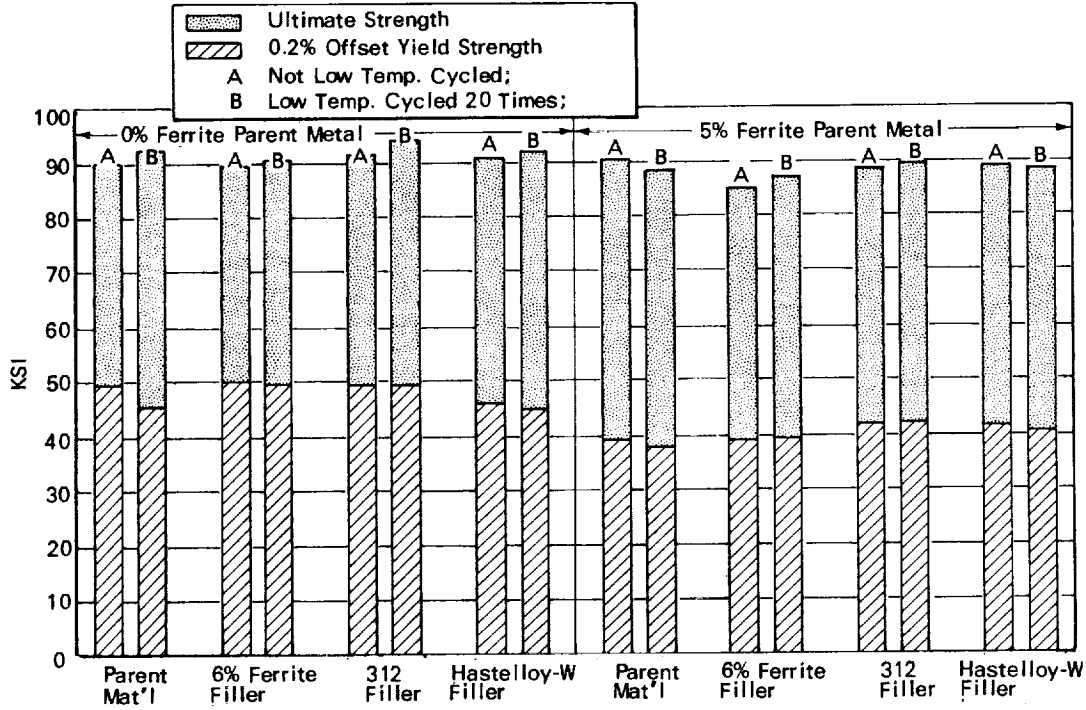

Figure 1. Effect of Filler Material on Mechanical Properties

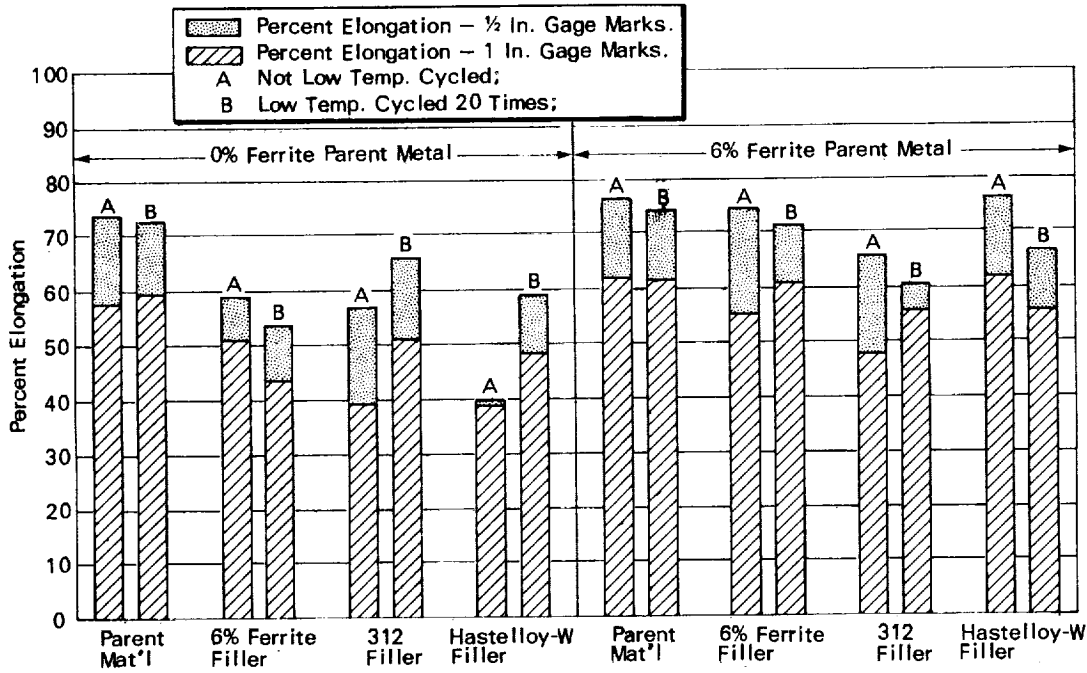

Figure 2. Effect of Filler Material On Mechanical Properties

222) showed no cracks when subjected to the fillerless fusion restraint test. The zero percent ferrite material (HT# 38260) had crater cracks indicating poor weldability and susceptibility to micro-fissuring, although cracking did not occur when making the weldments for this program.

Minor crater cracking was experienced on the parallel groove restraint tests on the zero percent ferrite parent material using the Hastelloy W filler and the 6% ferrite 347 filler materials. No cracks were present on the parallel groove restraint specimens using 312 filler material on either parent material. Severe surface cracking occurred when making the two parallel groove restraint tests using a zero percent ferrite filler metal which was high in the austenite range.

Source: R. E. Fish and J. N. Lamb of  
North American Rockwell Corp.  
under contract to  
Marshall Space Flight Center  
(MFS-18996)

*Circle 16 on Reader Service Card.*

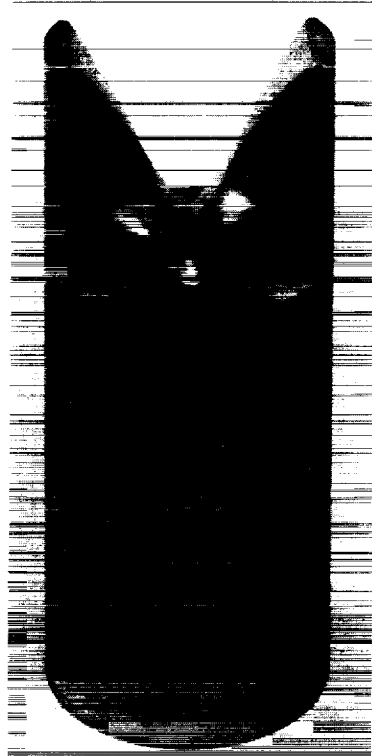

Figure 1. Single Billet

#### DEEP PENETRATION WELDS FOR HIGH STRESS APPLICATIONS

Deposition of nonmagnetic Inconel 625 by a series of puddle welds completely fills the void between two members of bimetallic shafts used in brushless alternators for space power systems. In addition to meeting magnetic requirements, these shafts must withstand stresses of up to 50,000 lb/in<sup>2</sup> imposed by the high rotational speeds.

The magnetic portions of the shaft are separated into poles by the non-magnetic material. Allowable pole-to-pole magnetic leakage determines the thickness of the non-magnetic material. When the magnetic and non-magnetic portions of the shaft are brazed together, the strength of the shaft is limited by the strength of the brazed joint or by voids in the brazed joint that may develop during

the brazing process.

The first fabrication step consists of bridging the thickness gap between two billets of AISI 4617 which have been machined as shown in Figure 1. This is done by depositing uncoated Inconel 625 wire by means of TIG welding on each billet until the required gap is established. After the two billets are joined, the deposition process is continued, as shown in Figure 2, until the void is completely filled. Periodic inspections are made of the welds to check for cracks. The completed billet is then heat treated and machined to the final configuration.

This method of fabrication results in a shaft that is equivalent in strength to the parent AISI 4617 material. The shaft was spin tested to a stress level of 50,000 lb/in<sup>2</sup> with no measurable yield occurring.

Source: S. Lumannick, W. E. Russell, and  
G. Tulisiak  
Lewis Research Center  
(LEW-11576)

*No further documentation is available.*



Figure 2. Mated Billets Showing Void to be Filled

### WATER-COOLED HEAT SINK TOOL FOR TUBE WELDING

A split-half, water cooled heat sink for use in welding standard 1/4-, 3/8-, 1/2-, or 5/8-in. O.D. tubing can be quickly attached to the tubing in the weld area, even in relatively inaccessible areas.

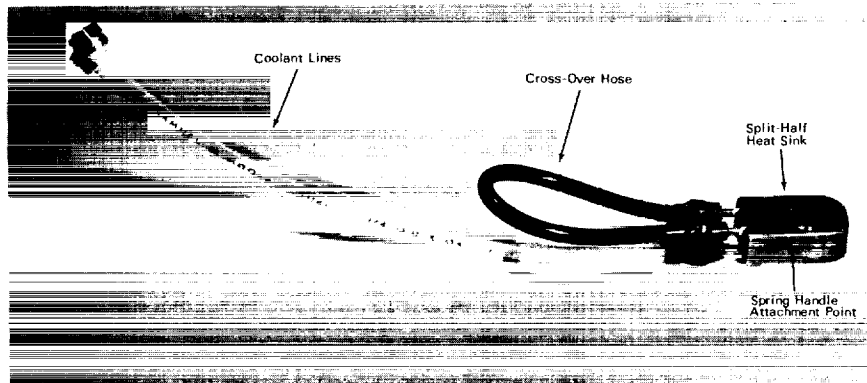

As shown in the illustration, the split-half heat sink is attached to coolant inlet and outlet lines and a cross-over hose is used to eliminate the requirement for gasketing and to assist circulation. Special spring handles (not shown) attach to recesses on either side of the heat sink to open and close the jaws as the handles are compressed and released.

Source: R. H. Thompson,  
P. D. Wisdom, and  
D. J. Reiman of  
North American Rockwell Corp.  
under contract to  
Manned Spacecraft Center  
(MSC-15768)

*Circle 17 on Reader Service Card.*

#### BUTT WELDER FOR FINE-GAGE WIRE

A device has been assembled from off-the-shelf components which will effectively weld fine gage wire as small as 0.001-in. in diameter. This device permits the welding of thermocouple junctions of the same small size as the wire with straight sections adjacent to the junctions. The electrode arrangement is designed to provide constant pressure on the joint during the welding operation while fully supporting the wires to prevent buckling or movement at the joint. It can be used wherever smooth butt welds of fine gage wires are needed and is adaptable for production work.

This butt welder is particularly suitable for welding a type of thermocouple made of tungsten/rhenium wire that becomes hard and brittle at the weld (a property that does not permit dressing of the weld or straightening of the wire, which is required when conventional welding techniques are employed). Weld junctions no larger than the nominal size of the wire can now be made on tungsten/rhenium wire, with straight sections adjacent to the junction. This method is versatile because it allows the perpendicular butt welding of fine wires and also permits the welding of fine

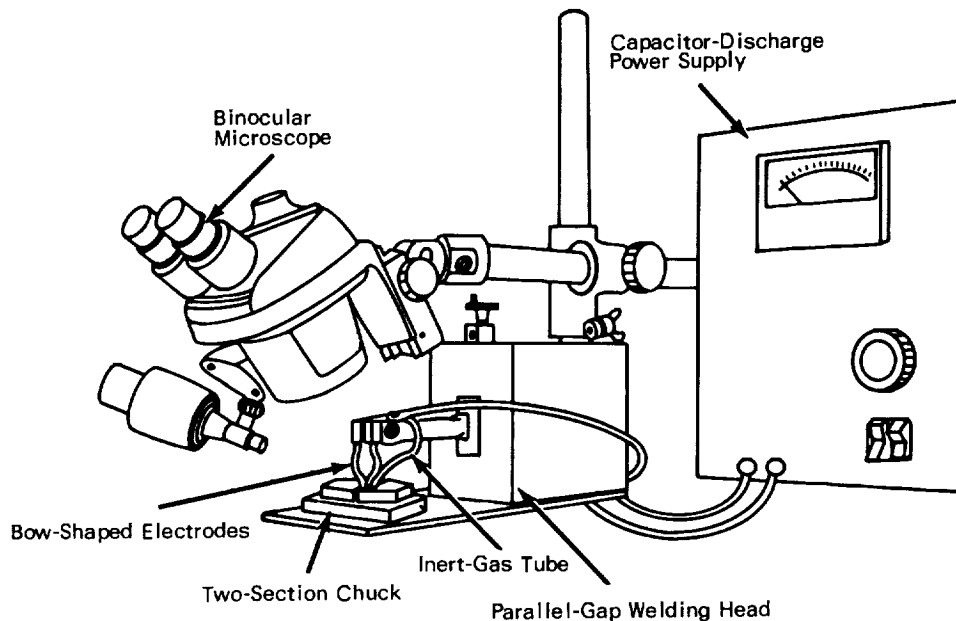

wire to the edge of metal ribbon.

The illustration shows a butt welder for fine gage wire that has been constructed partly from commercial items and partly from items made from stock materials. The welder consists of a capacitor-discharge power supply, a parallel-gap weld head with adjustable electrode gap and vertical force, bow-shaped electrodes, a copper weld base made in two sections separated by a thin insulator, an inert-gas tube, and a binocular microscope to view and position the work. The items made from stock materials were the bow-shaped electrodes, the weld base, and the inert-gas tube. The wires to be welded are first cut square, or carefully matched if slightly beveled. The wires must be clean and free of burrs.

Source: W. B. Kabana  
Langley Research Center  
(LAR-10103)

*Circle 18 on Reader Service Card.*

### SPINARC GAS TUNGSTEN ARC TORCH HOLDER

A prototype device for semiautomatic gas tungsten arc (GTA) welding of small diameter aluminum tubing consists of a rotating fixture that may be attached to the tube requiring welding (see fig.). The welding torch is positioned in the holder, which is rotated around the weld joint. Because the torch nozzle is always centered over the weld joint where the arc is started, the arc length remains constant. Since the tungsten is preset for the weld, arc initiation is easier and the process of "searching for the joint" through a dark welding lens is eliminated.

The device was fashioned into an air-cooled unit by modifying a commercial torch. This was accomplished by removing the water and gas lines and adding an adapter to permit gas to flow through the power cable hose. For clearance, the torch handle was also removed. Precise location of the tool on the tube was maintained by three rollers under spring tension. The torch operator was also able to control the arc length, torch angle, and spring tension by means of three points of adjustment on the tool.

Source: J. L. Crockett and  
D. F. Brace of  
North American Rockwell Corp.  
under contract to  
Manned Spacecraft Center  
(MSC-15646)

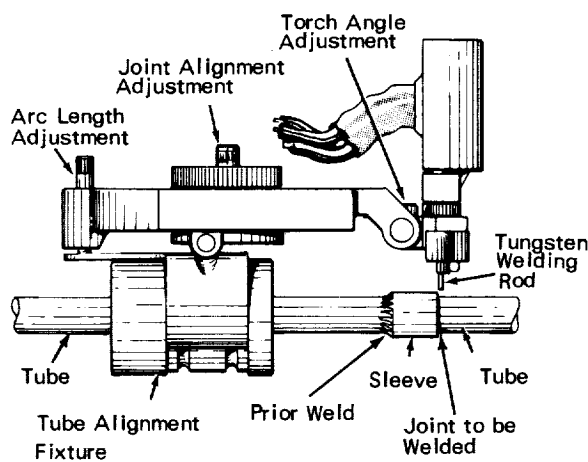

*No further documentation is available.*

## PORTABLE MACHINE WELDING HEAD AUTOMATICALLY CONTROLS ARC

This portable weld tool provides full automatic control of the four basic fusion type machine-weld functions (arc voltage, current, wire feed, and electrode travel speed) in all welding attitudes. The equipment can make machine repairs out-of-station and on the side opposite the original weld.

Previously, weld repairing was accomplished by either manual means or by in-station machine welding, or a combination of both. The in-station machine repairs had to be made from the same side and with the same tool as for the original weld, thus posing weld penetration control problems.

Universal vacuum pads mount the machine to all but the most irregular surfaces. A synchronous motor drives the weld head by means of a worm-type reduction gear in response to inputs from a weld programmer that senses the correct weld function parameters by the arc voltage performance.

With this technique, less material must be removed in eliminating inclusions than was the case with prior methods. This device is readily adaptable to commercially available straight polarity dc weld packs and current capacity (weld penetration capability) is limited only by the torch size employed.

Source: M. A. Robb and  
C. E. Oleksiak of  
North American Rockwell Corp.  
under contract to  
Marshall Space Flight Center  
(MFS-12763)

*Circle 19 on Reader Service Card.*

## CLOSED CIRCUIT TV SYSTEM MONITORS WELDING OPERATIONS

A TV camera system incorporating a special vidicon tube with a gradient density filter has been devised for use in remote monitoring of

TIG (tungsten-inert gas) welding of stainless steel. The welding operations involve complex assembly welding tools and welding skates in areas of limited accessibility. The welding skates include servo motors for feeding and positioning the filler wire, torch positioning, arc length control, and skate drive control. The camera is positioned so that the weld puddle, the filler wire feeding into the puddle, the torch, and the seam to be welded are in full view of the camera. This system enables the operator to make remote precision adjustments while viewing the actual welding operation on the TV screen. A permanent record of the welding process can be recorded on tape for later study.

Source: M. Gilman, et al of  
North American Rockwell Corp.  
under contract to  
Manned Spacecraft Center  
(MSC-11002)

*Circle 20 on Reader Service Card.*

#### FLEXIBLE DRIVE ALLOWS BLIND MACHINING AND WELDING IN HARD-TO-REACH AREAS

A machine/weld head is connected to a power and control unit by a flexible transmission shaft and incorporates a locking-indexing collar onto the machine/weld head to allow the head to be placed and held in position.

The power and control unit contains an electric motor that provides mechanical power through a gear train coupled to the transmission shaft. This unit is also drilled to provide a passage for inert gas, used to control the atmosphere during welding.

The flexible transmission shaft is inside a neoprene extrusion that contains three passages running lengthwise for gas, electrical power to the head, and the bidirectional flexible shaft.

The machine/weld head is a power reduc-



tion unit comprised of a housing, power reduction and drive unit, cutter/weld tools, and a locking-indexing collar. The collar is split and has a centrally bored hole sized to fit a flange in the area to be welded and machined. During the machine operation a hollow milling cutter is inserted in the head. The head is then assembled onto the transducer and the cutting tool is controlled by an external knurled ring. The head is then dismantled and the weld tip installed. The weld tip is a single wire electrode mounted on a ring carrier and positioned by rotating the external knurled ring until preset stops are contacted.

Source: R. G. Rohrberg and  
D. E. Harvey of  
North American Rockwell Corp.  
under contract to  
Manned Spacecraft Center  
(MSC-524)

*Circle 21 on Reader Service Card.*

#### AUTOMATIC REEL CONTROLS FILLER WIRE IN WELDING MACHINES

An automatic filler wire reel has been constructed for use on automatic welding equipment. The reel maintains constant, adjustable tension on the wire during welding operations and rewinds the wire from the wire feed unit when welding operations are terminated.

Present automatic welding equipment does not provide for takeup of the slack in the reeled filler wire when each welding operation is terminated. The springy wire frequently unwinds, snarls and slips over the reel flange and becomes fouled when the feed motor is restarted. Because of the rework caused by these problems, the quality of the weld may be affected.

In this application, a spring loaded clutch mechanism has sufficient tension to maintain the filler wire in a taut condition during welding operations. The wire feed unit, however, has sufficient power to cause the clutch to slip

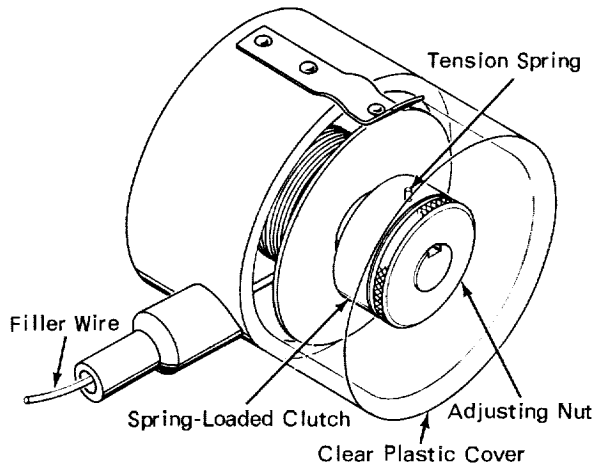

and this feeds the wire smoothly to the electrode/workpiece area. Upon completion of the welding operation, the wire feed unit releases the wire and the clutch spring unloads, causing the reel to rewind the unused portion of filler wire. An adjusting nut in the reel permits setting of the clutch spring tension and travel limits to accommodate a range of lengths of wire plus wire feed unit power.

Several of these units are presently being used on automatic welding equipment to fabricate hardware for the Apollo program. This device is readily adaptable for use with existing automatic welding equipment without modifications.

Source: A. V. Millett of  
North American Rockwell Corp.  
under contract to  
Manned Spacecraft Center  
(MSC-416)

*Circle 22 on Reader Service Card.*

#### MECHANICAL SHIELDING REDUCES WELD SURFACE CRACKING IN 6061-T6 ALUMINUM

A mechanical shield of high melting point material, held in place about the weld bead area, protects the parent metal from the effects of the arc, thus eliminating heat check cracks.

A welding 6061-T6 aluminum pieces with high frequency ac tungsten arc equipment, a common fault has been heat check cracks occurring in the heat-affected zone of the parent metal about the weld puddle. This causes weld rejection by inspection and subsequent rework by production facilities, all of which is quite costly.

The shielding material, of proper thickness to handle the anticipated heat load, is center drilled with an aperture sufficient to cover the weld bead while shielding the parent metal about it. A copper overlay with a somewhat larger center aperture is placed over the shield and the assembled components are held in

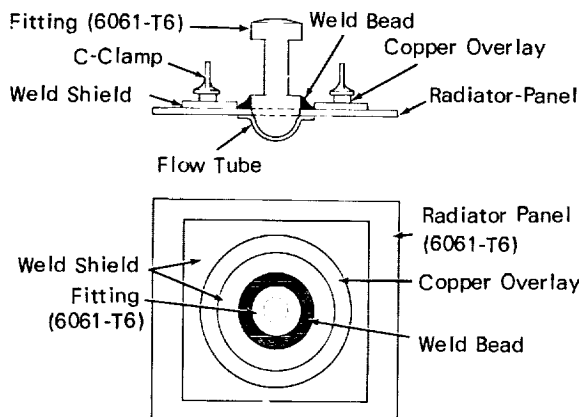

place by conventional metal C-clamps.

Use of a 0.020-inch tungsten plate eliminated, almost completely, heat check cracking around the periphery of the weld bead. However, to overcome inherent problems associated with the properties of tungsten, other metals and ceramics with a melting point higher than 4500°F were evaluated as shields. Results of these investigations reveal that Columbium #752, one of the metals tested, effectively eliminated heat cracking around the weld area, while exhibiting excellent properties as a shielding material. Etching and dye-penetrant inspection indicated no cracking around the weld area when this shielding technique was used.

Source: J. E. Hill of  
North American Rockwell Corp.  
under contract to  
Manned Spacecraft Center  
(MSC-11494)

*Circle 23 on Reader Service Card.*

