

2001
NASA TM-X-69908

SYNCHRONOUS METEOROLOGICAL SATELLITE SYSTEM DESCRIPTION DOCUMENT

VOLUME 4

FEBRUARY 1972



———— GODDARD SPACE FLIGHT CENTER ————
GREENBELT, MARYLAND

(NASA-TM-X-69908) SYNCHRONOUS
METEOROLOGICAL SATELLITE SYSTEM
DESCRIPTION DOCUMENT, VOLUME 4 (NASA)
103 p HC \$8.25
102. CSCL 22B
N74-25320
G3/31 Unclass 40314 *102*

SYNCHRONOUS METEOROLOGICAL SATELLITE
SYSTEM DESCRIPTION DOCUMENT

Volume 4

Prepared by

J. Lahzun
Ground Systems Manager
SMS Project

February 1972

GODDARD SPACE FLIGHT CENTER
Greenbelt, Maryland

;

CONTENTS

Section 6

SYNCHRONOUS METEOROLOGICAL SATELLITE GROUND STATION DESCRIPTION

	<u>Page</u>
6.1 INTRODUCTION	6-1
6.2 FACILITY DESCRIPTION	6-2
6.2.1 STATION GROUNDING SYSTEM	6-7
6.2.2 ELECTRICAL PROVISIONS	6-7
6.3 GROUND STATION INTEGRATION (GSI)	6-7
6.3.1 SYSTEM DESCRIPTION	6-7
6.3.1.1 Suitland-to-Wallops Data Interface	6-8
6.3.1.2 Wallops-to-Suitland Data Interface	6-11
6.3.2 FREQUENCY ASSIGNMENTS	6-11
6.3.3 GROUND STATION CONFIGURATION	6-11
6.3.4 RACK STANDARDS	6-13
6.3.5 MASTER CONTROL CONSOLE (MCC)	6-22
6.4 S-BAND ANTENNA	6-22
6.4.1 REFLECTOR ASSEMBLY	6-23
6.5 PARAMETRIC AMPLIFIER	6-26
6.5.1 CONTROL AND MONITOR PANELS	6-26
6.6 S-BAND RECEIVER	6-28
6.7 TELEMETRY AND COMMAND	6-31

CONTENTS (continued)

	<u>Page</u>
6.7.1 TELEMETRY RECEIVER	6-31
6.7.2 PULSE CODE MODULATION DATA HANDLING EQUIPMENT (PCM-DHE)	6-32
6.7.3 PCM TELEMETRY DATA	6-33
6.7.4 REAL-TIME DATA UNIT (RTDU)	6-33
6.7.4.1 General Description	6-34
6.7.5 COMMAND ENCODER	6-36
6.7.5.1 Command Message Format	6-38
6.7.5.2 Pyrotechnic Commands	6-39
6.7.6 SYNCHRONOUS CONTROLLER	6-39
6.7.7 VHF ANTENNA	6-39
6.7.7.1 VHF Transmitting Equipment	6-40
6.7.7.2 VHF Receiving Equipment	6-40
6.8 S-BAND TRANSMITTER	6-40
6.8.1 METERS AND CONTROLS	6-40
6.9 FREQUENCY AND TIMING STANDARD	6-44
6.9.1 LORAN-C SIGNAL TIMING; REFERENCE PULSES	6-45
6.9.1.1 USNO Time-of-Coincidence (Null) Ephemeris	6-50
6.9.1.2 Loran-C Timing Worksheet	6-50
6.9.2 BASIC SYSTEM FOR MEASURING LOCAL TIME	6-50

CONTENTS (continued)

	<u>Page</u>
6.9.3 MEASURING FREQUENCY	6-52
6.9.3.1 Probably Error	6-54
6.9.3.2 Traceability	6-54
6.9.3.3 Substantiation of Data	6-54
6.10 WEATHER FACSIMILE (WEFAX)	6-56
6.11 DATA COLLECTION SYSTEM (DCS)	6-57
6.11.1 INTERROGATED DCPRS	6-61
6.11.2 SELF-TIMED DCPRS	6-63
6.11.3 INTERROGATION FORMAT	6-63
6.12 TRILATERATION RANGING SYSTEM	6-65
6.13 SYNCHRONIZER/DATA BUFFER (S/DB)	6-67
6.13.1 SPACECRAFT DATA INTERFACES	6-67
6.13.1.1 Quadrphase Data Format	6-67
6.13.1.2 VISSR Scan Control	6-70
6.13.2 MECHANICAL DESCRIPTION	6-71
6.13.2.1 External Interfaces	6-74
6.13.3 SYSTEM DESCRIPTION	6-74
6.13.3.1 Monitor	6-79
6.13.3.2 Retransmission Modes	6-79
6.13.3.3 Image Format	6-81

CONTENTS (continued)

	<u>Page</u>
6.14 DIRECT READOUT GROUND STATION (DRGS)	6-81
6.14.1 INSTRUMENTATION VAN	6-84
6.14.1.1 Ceiling and Lighting	6-84
6.14.1.2 Walls and Floor	6-84
6.14.1.3 Furnishings	6-84
6.14.1.4 Safety Equipment	6-86
6.14.1.5 Environmental Control Equipment	6-86
6.14.1.6 Electrical Power Distribution	6-86
6.14.2 ANTENNA TRAILER	6-86
6.14.2.1 Characteristics	6-88
6.14.2.2 Specifications	6-88
6.14.2.3 Capabilities and Limitations	6-89
6.14.3 SYSTEM DESCRIPTION	6-89
6.14.3.1 Antenna/Pedestal Assembly	6-91
6.14.3.2 Receiving and Demodulator Processing	6-91
6.14.3.3 VISSR Demodulation and Synchronization Electronics	6-91
6.14.3.4 Signal Simulator	6-93
6.14.3.5 Frame Synchronization	6-93
6.14.3.6 Data Randomization and Word Complimenting	6-94
6.14.4 RECORDER/PROCESSOR	6-94

ILLUSTRATIONS

<u>Figure</u>		<u>Page</u>
6-1	SMS System Functional Diagram	6-3
6-2	View of East Elevation	6-4
6-3	First Floor Layout Plan	6-5
6-4	Basement Layout Plan	6-6
6-5	CDA Station System Block Diagram	6-9
6-6	Instrumentation Room Floor Plan Layout	6-14
6-7	Typical Examples of Rack Numbering System	6-21
6-8	Master Control Console	6-23
6-9	Antenna Structure, Side View	6-24
6-10	Parametric Amplifier Subsystem Block Diagram	6-27
6-11	S-Band Receiver Functional Diagram	6-29
6-12	Real-Time Data Unit Block Diagram	6-35
6-13	Command Encoder Block Diagram	6-37
6-14	S-Band Transmitter Subsystem Block Diagram	6-41
6-15	Timing of Loran-C Signals	6-46
6-16	Factors in Total Timing Delay	6-47
6-17	One-Hop Skywave Correction	6-48
6-18	Typical Loran-C Waveform Record	6-50
6-19	Loran-C Timing Worksheet	6-51
6-20	Basic System for Loran-C Timing	6-52

ILLUSTRATIONS (continued)

<u>Figure</u>		<u>Page</u>
6-21	Master Timing System	6-53
6-22	S-Band Conversion, Block Diagram	6-58
6-23	Interrogated DCPRS, Simplified Block Diagram	6-59
6-24	Self-Timed DCPRS, Simplified Block Diagram	6-59
6-25	DCPRS/SC/CDA Detailed Frequency Plan	6-63
6-26	Typical Interrogation Message	6-65
6-27	Trilateration Range and Range Rate System, Block Diagram	6-66
6-28	Synchronizer/Data Buffer System Configuration	6-68
6-29	VISSR Thermal Channel and Visible Channels IGFOV Arrangement	6-69
6-30	Computer & Peripherals and Central Timing Unit Equipment Layout	6-72
6-31	Data Handling Unit and Analog Processing Unit Equipment Layout	6-73
6-32	Synchronizer/Data Buffer System, Block Diagram	6-75
6-33	VISSR PCM Data Format, Mode 1	6-77
6-34	VISSR PCM Data Format, Mode 2	6-77
6-35	Stretched Video Format	6-82
6-36	VISSR Image	6-83
6-37	Direct Readout Ground System Instrumentation Van	6-85
6-38	Direct Readout Ground System Antenna Trailer	6-87

ILLUSTRATIONS (continued)

<u>Figure</u>		<u>Page</u>
6-39	Direct Readout Ground System, Block Diagram	6-90
6-40	Digital Interface Electronics System Configuration	6-92

TABLES

<u>Table</u>		<u>Page</u>
6-1	CDA Station Frequency Plan	6-12
6-2	CDA Station Modem Frequency Plan	6-12
6-3	CDA or STADAN Station Plan	6-13
6-4	Data User Frequency Plan	6-13
6-5	Rack Numbering System	6-15
6-6	S-Band Antenna Characteristics	6-25
6-7	Pre-Amplifier Characteristics	6-30
6-8	Down-Converter Characteristics	6-30
6-9	DCPRS Modules and Their Functions	6-60
6-10	Interrogated DCPRS Specification	6-62
6-11	Self-Timed DCPRS Specification	6-64
6-12	Retransmission Modes	6-81

Section 6

SYNCHRONOUS METEOROLOGICAL SATELLITE GROUND STATION DESCRIPTION

6.1 INTRODUCTION

The command and data-acquisition (CDA) station for the Synchronous Meteorological Satellite (SMS) program is located on the Eastern shore of Virginia along the Atlantic coast of the Demarva peninsula, approximately 40 miles southeast of Salisbury, Maryland.

The CDA station functions as the satellite control and major data collection center for the SMS operations, and will be expanded in the future to operate with a two spacecraft system. The station functions include:

- Reception and processing of the visible infrared spin-scan radiometer (VISSR) data from the spacecraft telescope/radiometer system.
- Reduction of the baseband bandwidth of the VISSR data, and retransmission by the spacecraft to "small" data utilization stations (DUS) within the viewing area of the satellite.
- Reception and processing of all data from up to 10,000 data collection platforms (DCP's).
- Transmission of radiometer and DCP data to the National Oceanic and Atmospheric Administration (NOAA) at Suitland, Maryland by the Wallops to Suitland, Md. data link.
- Interrogation of such DCP's as may be provided with receive capabilities.
- Performance of ranging measurements utilizing the satellite transponder and two remote slave stations, thus providing information for picture gridding.
- Transmission of commands to the satellite for control and utilization as instructed by the Satellite Operations and Control Center (SOCC).
- Reception, processing, and transmission of spacecraft housekeeping data to SOCC.

- Transmission of weather facsimile (WEFAX) pictures from the CDA station through the spacecraft to automatic picture transmission (APT) stations.

Figure 6-1 is a functional system diagram which shows the various communications links from the CDA station to the SMS spacecraft, automatic picture transmission (APT), data utilization stations (DUS), data collection platforms (DCP's) and NOAA at Suitland, Maryland.

6.2 FACILITY DESCRIPTION

The expansion of the existing operations building is intended to provide additional operations area and relieve problems arising from the present lack of storage space and lavatory facilities.

The building has been expanded 52 feet to the south while maintaining the existing 52 foot width. This results in approximately 2500 square feet of space on the first floor and 2500 square feet of basement area (see Figure 6-2).

A breakdown of the first floor area gives 2000 square feet of raised floor operations room, 200 square feet of office, a small storage room, lavatory, and an expansion of the existing ready room (see Figure 6-3).

A portion of the basement is utilized as a mechanical room for the air handling units. The remaining 2000 square feet is an open storage area (see Figure 6-4). It is intended to provide a storage area and to relieve congestion of project rooms in the existing building.

Concrete encased duct banks have been constructed to provide access to the new operations area from the south side; twelve 4-inch duct banks for signal cables from the antenna and four 4-inch duct banks for power cables from the utility building.

The interior of the utility building is also being changed. A portion of storage space is occupied by the new air conditioning compressor, and boiler. This is due to the expansion of the operations building.

The existing utilities e.g., water and sewage are considered adequate and no changes are required in these areas.

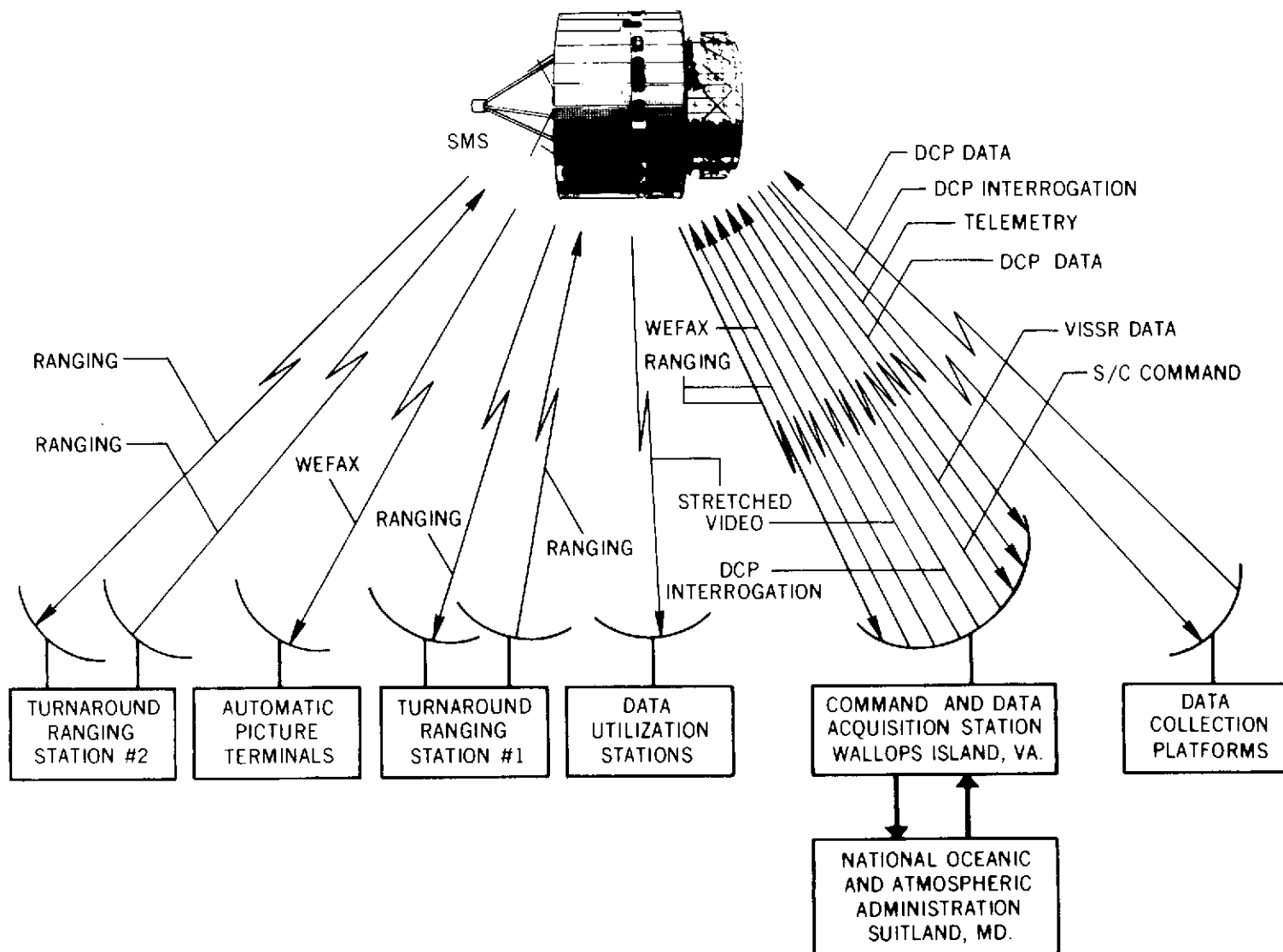

Figure 6-1. SMS System Functional Diagram

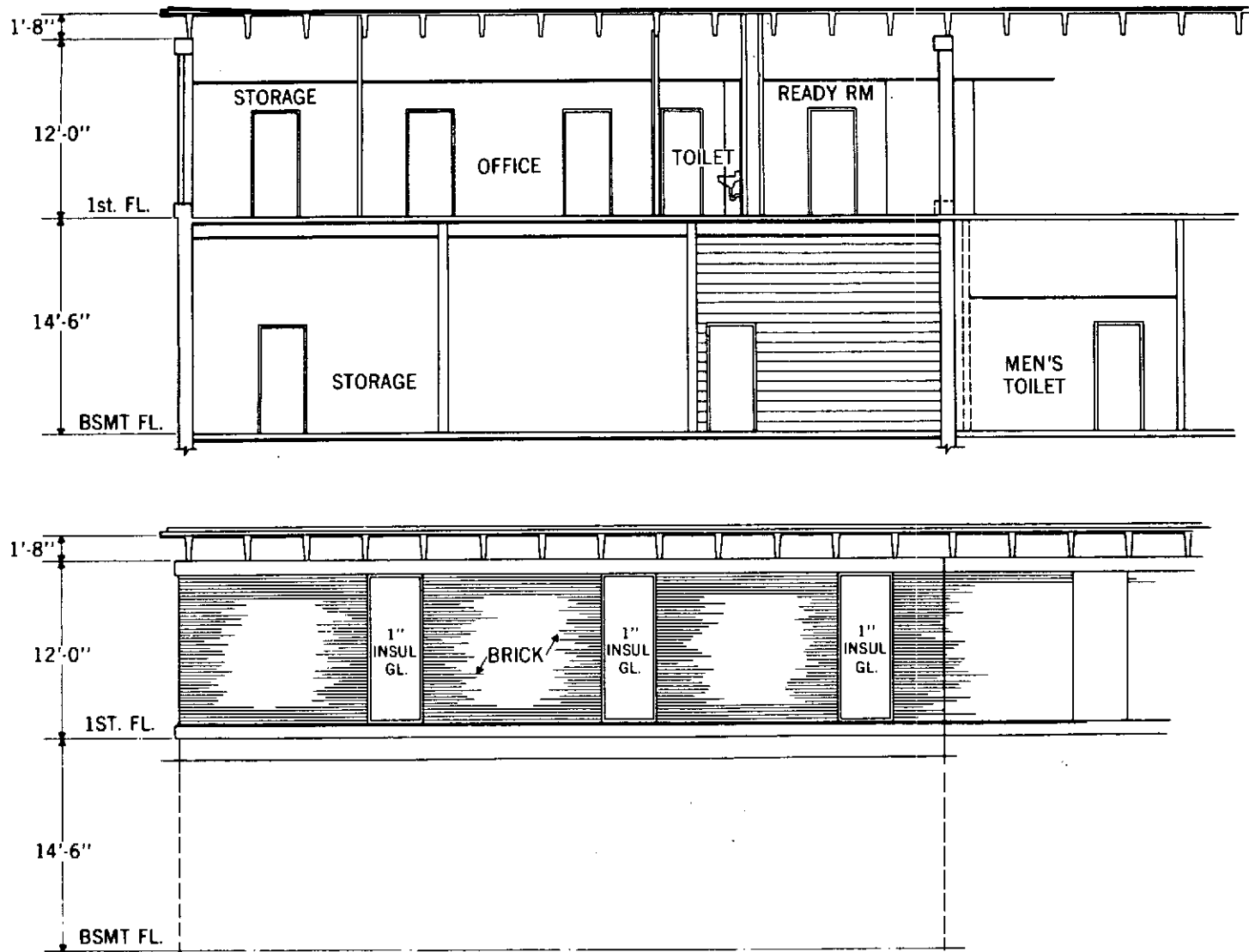

Figure 6-2. View of East Elevation

6-5

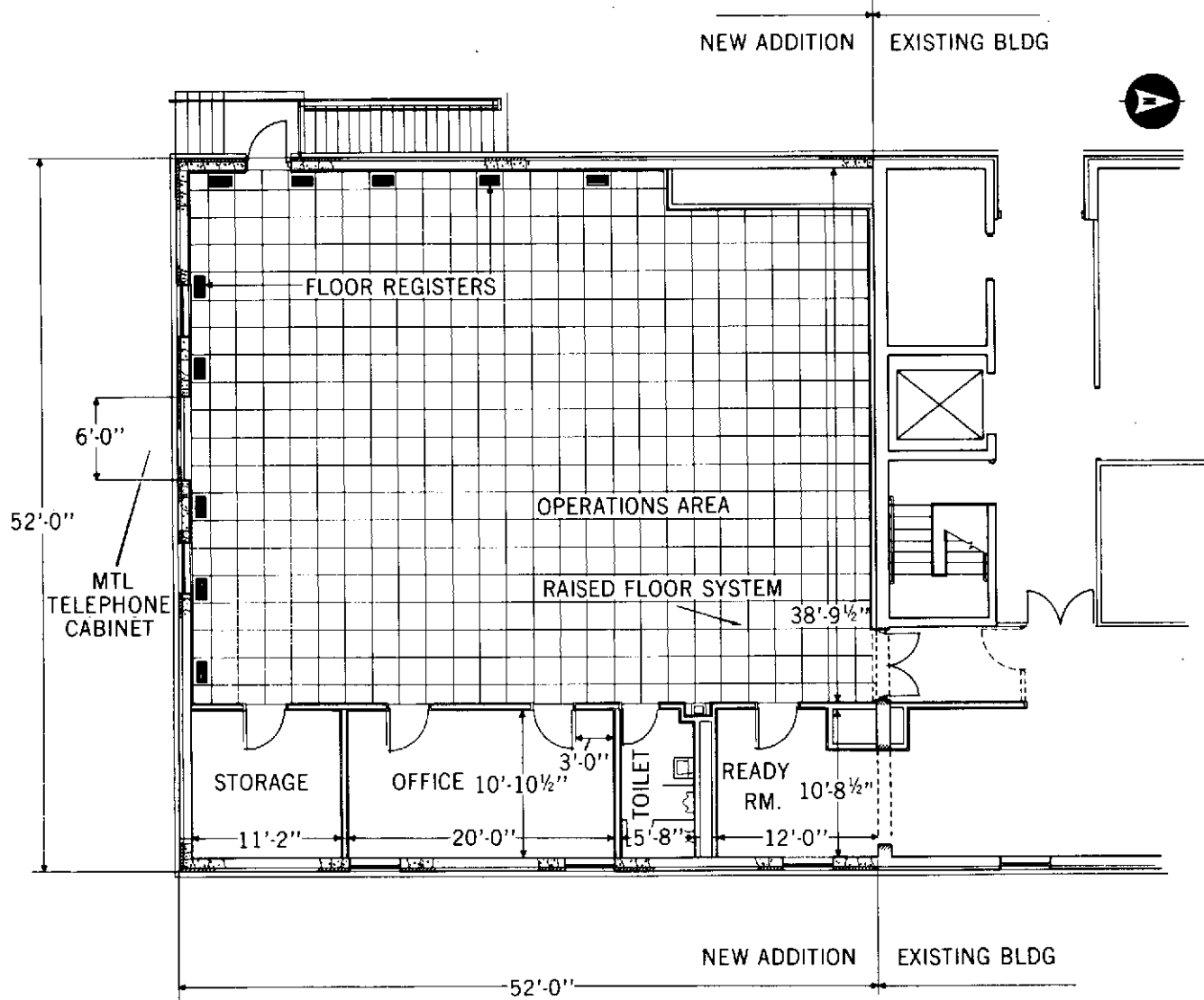

Figure 6-3. First Floor Layout Plan

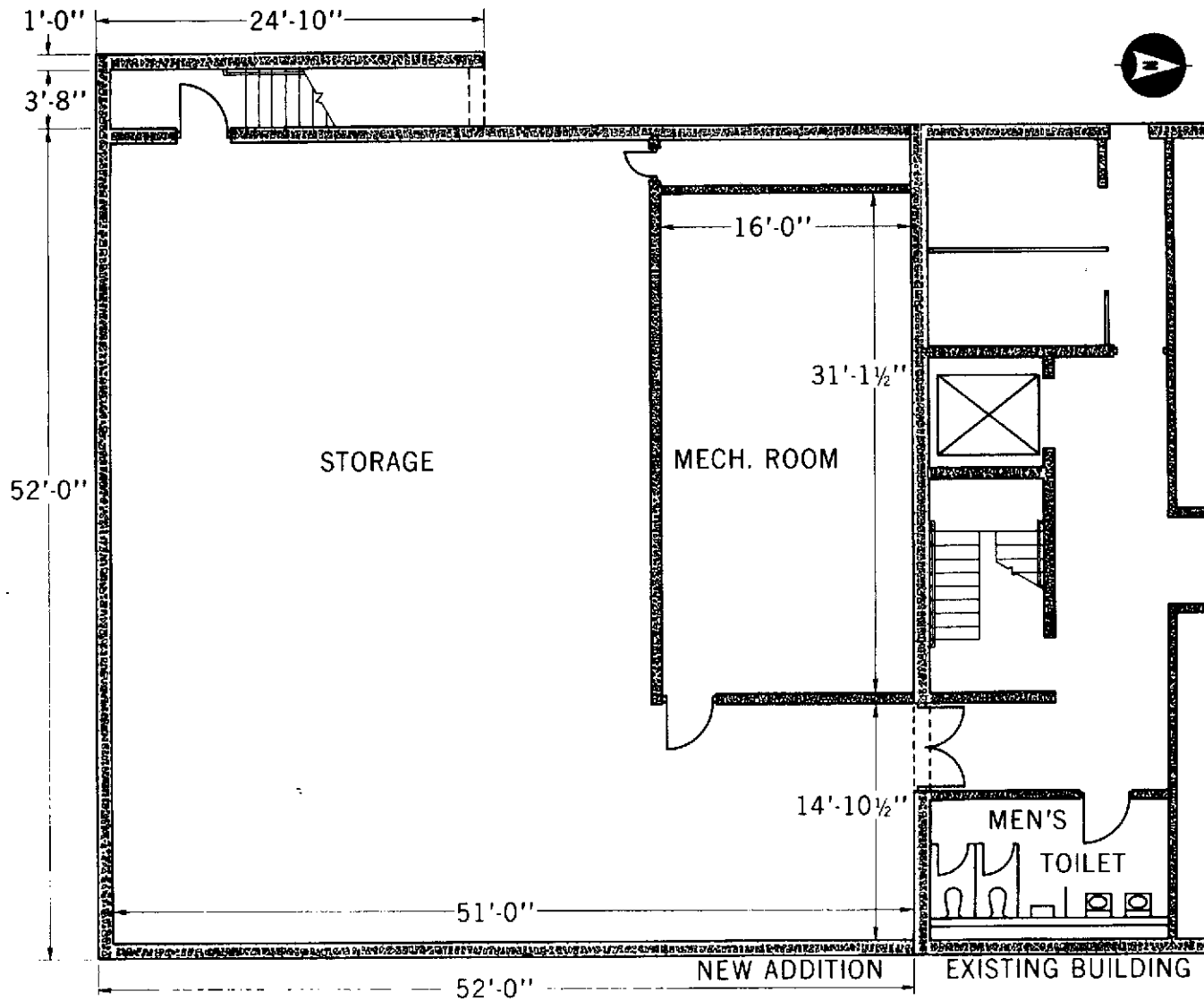

Figure 6-4. Basement Layout Plan

6.2.1 STATION GROUNDING SYSTEM

The antenna and facility grounding system employs the same requirements used for satellite tracking and data-acquisition network (STADAN) stations. The station grounding system consists of two separate, isolated systems: the signal ground system and the safety ground system.

The signal ground system provides an insulated low noise common-bus network for the grounding of electronic equipment and is insulated from earth at all points except at one point where the system is connected to the signal ground rod field. Noise, due to the flow of ground currents caused by a potential difference between two separated points of earth contact, is minimized by insulating the system from the ground at all points except one.

The safety ground system provides an uninsulated common-bus network for the grounding of electrical equipment (power panels, hydraulic pump motors, etc.), buildings, and antenna structures. The safety ground system combines the ground points at various station structures into a common-bus ground network to insure that a definite common ground is continuously maintained to reduce the hazard of shock to personnel.

6.2.2 ELECTRICAL PROVISIONS

Two new power panel boards for technical power and utility power have been provided in the basement of the new addition to accommodate future electronic equipment. Each panel board has an approximate 75-kw load capacity and includes twenty-one 20 amp, 1-pole molded case circuit breakers and twenty-one 30 amp, 1-pole molded case circuit breakers.

6.3 GROUND STATION INTEGRATION (GSI)

The GSI effort is primarily an engineering task that is required to develop and prepare the Wallops CDA station for operational use with the SMS.

The primary objective of the GSI effort is to integrate all equipment into the CDA station, and to ensure the readiness of the station to fulfill its mission as a command and data-acquisition facility for the SMS program.

6.3.1 SYSTEM DESCRIPTION

The CDA station contains the following major subsystems for use in support of operations with the SMS spacecraft.

- Antenna
- Parametric amplifier
- Receiver
- Transmitter
- Telemetry and command
- Synchronizer/data buffer (line stretcher)
- Trilateration ranging
- Data collection
- Frequency and timing

Typical SMS data, e.g. wideband VISSR, DCP reports, ranging, and telemetry are received by the S-band antenna, and then amplified by the cooled parametric amplifier and receiver equipment (see Figure 6-5). The receiver output is then interfaced with a multicoupler in the instrumentation room by means of the 50-ohm cable running between the antenna and the instrumentation room. The data outputs from the multicoupler are then distributed to each individual subsystem.

Subsystem modulated outputs, which interface with the S-band transmitter at the low-level signal combiner in the instrumentation room, include stretched VISSR, interrogation signals for the two turnaround ranging stations, interrogation signals for the DCP's, spacecraft commands, and WEFAX data.

The combiner output is at the desired intermediate frequency and level to interface with the frequency up-converter in the antenna azimuth deck equipment room. After the signal is up-converted, it is amplified by the power amplifier to the desired level, and then transmitted to the spacecraft.

6.3.1.1 Suitland to Wallops Data Interface

The stretched VISSR gridding and annotation data are transmitted directly from a CDC-6600 computer at Suitland, to the CDA station using a landline circuit. The data format is compatible for interfacing with the synchronizer/data buffer system.

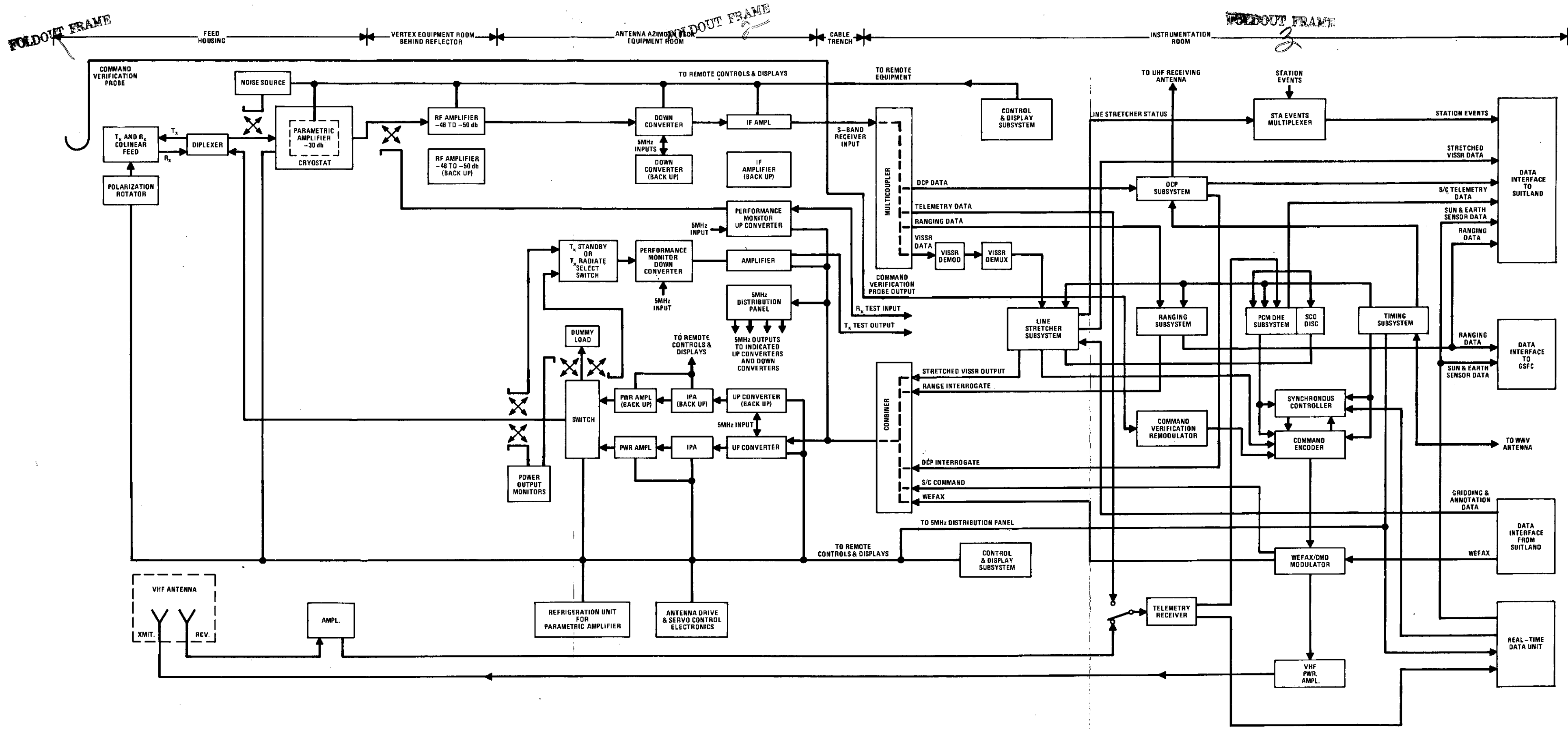

Figure 6-5. CDA Station System Block Diagram

The WEFAX data are transmitted from Suitland, to the CDA station by a second data circuit, and are directly interfaced with the WEFAX modulator and transmitter subsystem for transmission to SMS.

The third data circuit from Suitland, to the CDA station is used for transmission of DCP interrogation data commands and schedules. This circuit is a duplex voice channel, but may be modified as the quantity of traffic increases.

6.3.1.2 Wallops-to-Suitland Data Interface

One data circuit is used exclusively to transmit PCM telemetry data from the CDA station to Suitland. The PCM telemetry data are then interfaced with the EMR-6135 computer and related (SOCC) displays. An additional data circuit is used to transmit the real-time telemetry data to Suitland for data processing.

The trilateration ranging data are transmitted over another landline circuit. The data format is compatible with the EMR-2700 series-bit and frame synchronizers and the EMR-6135 computer at Suitland.

The CDA station events data are multiplexed and transmitted to Suitland by a third data circuit. At Suitland, the data are interfaced with the EMR-2700 series-bit and frame synchronizers and an EMR-6135 computer.

All data received at the CDA station from the DCP's are sent to Suitland on a separate data circuit for further distribution.

The stretched VISSR (4 by 4 nmi) data are sent to Suitland over a separate data circuit. These data are interfaced with existing digital handling equipment which operates with a Murihead D-700 display system.

6.3.2 FREQUENCY ASSIGNMENTS

Tables 6-1 through 6-4 indicate the frequency plan that is used for operations with SMS. Table 6-1 identifies the frequency plan for the CDA station, and Table 6-2 lists the modulator and demodulator intermediate frequencies. The launch support frequencies are identified in Table 6-3. The frequencies assigned for launch support are also used during the spacecraft eclipse period and as backup to the S-band communications system. Table 6-4 identifies the frequency plan for other ground stations which are part of the SMS system.

6.3.3 GROUND STATION CONFIGURATION

A ground station configuration plan has been developed for designation and identification of equipment using an alpha-numerical system. The system is used

Table 6-1

CDA Station Frequency Plan

Receive Frequencies	MHz
Wideband VISSR	1681.6 ± 11.6
S-band telemetry	1694.0 ± 0.1
DCP reports	1694.5 ± 0.2
Ranging	1687.1 ± 4.1
UHF DCP interrogation monitor	468.825 ± 0.075
Stretched VISSR	1687.1 ± 4.1
WEFAX	1690.1 ± 0.025
Transmit Frequencies	MHz
Stretched VISSR	2029.1 ± 4.1
S-band command	2034.2 ± 0.030
DCP interrogate	2034.9 ± 0.075
Ranging	2029.1 ± 4.1
WEFAX	2032.1 ± 0.025
UHF DCP standard	401.9 ± 0.2

Table 6-2

CDA Station Modem Frequency Plan

Modulator Output Frequencies	MHz
Stretched VISSR	69.1
S-band command	74.2
Ranging	69.1
DCP interrogate	74.9
WEFAX	72.1
Demodulator Input Frequencies	MHz
Wideband VISSR	70.0
S-band telemetry	74.0
Ranging	67.1
DCP reports	74.5
Stretch VISSR	67.1
WEFAX	70.1

Table 6-3

CDA or STADAN Station Plan

VHF Receive Frequencies	MHz
SMS telemetry VHF ranging	136.38 135.565
VHF Transmit Frequencies	MHz
SMS command VHF ranging	148.56 148.56

Table 6-4

Data User Frequency Plan

Receiver Frequencies	MHz
Stretched VISSR WEFAX DCP	1687.1 \pm 4.1 1690.1 \pm 0.025 468.825 \pm 0.075*
Transmit Frequencies	MHz
DCP	401.9 \pm 0.200**

*Represents satellite transmission bandwidth. Each DCP requires a bandwidth of \pm 0.0005 MHz.

**Represents satellite receiver bandwidth. Each DCP requires a bandwidth of \pm 0.0015 MHz.

to specify subsystem, rack, panel, and component parts. The instrumentation room floor plan that has been developed is shown in Figure 6-6, and the complete rack numbering system is shown in Table 6-5.

Three typical examples are shown in Figure 6-7, clarify the mechanics of this rack numbering system.

6.3.4 RACK STANDARDS

In order to maintain a uniform appearance for the CDA station equipment, the standards shown on page 21 have been established for all the racks.

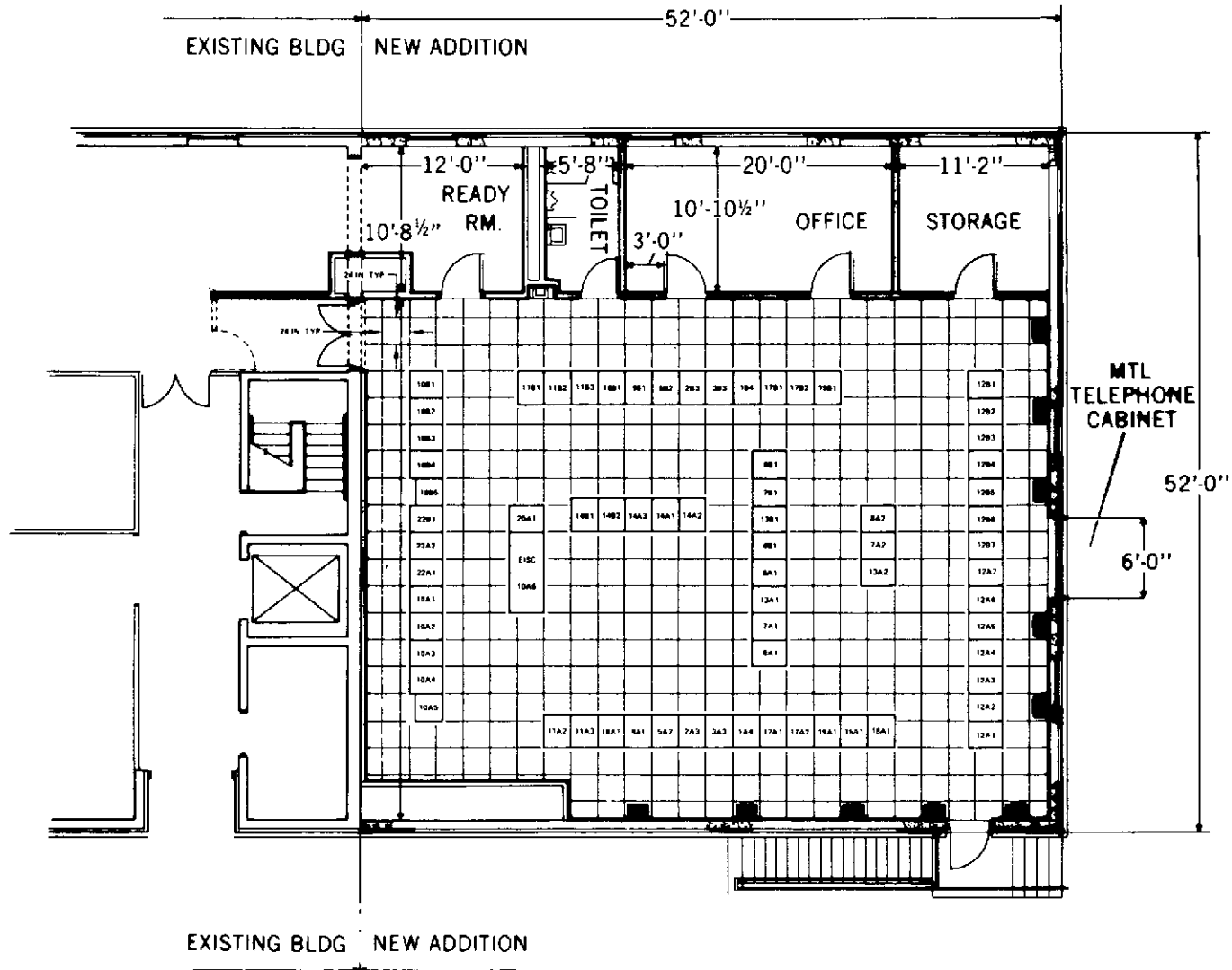

Table 6-5

Rack Numbering System

CDA STATION A		
<u>60-Ft Antenna</u>		
1A1	Antenna electro-mechanical	(unit)
	Transmitter/receiver co-linear feed	(unit)
	Polarization rotator	(unit)
	Command and verification probe	(unit)
	All units are mounted at or in the near vicinity of the antenna feed housing	(unit)
1A2	Diplexer mounted in the vertex room behind reflector	(unit)
1A3	Antenna drive and servo control mounted in azimuth deck equipment room	(unit)
1A4	Antenna control and display located in the CDA operations room	1 (rack)
<u>Parametric Amplifier</u>		
2A1	Noise-source coupler and parametric amplifier mounted in the vertex room behind reflector	(unit)
2A2	Refrigeration unit mounted in azimuth deck equipment room	(unit)
2A3	Remote control, display, and noise-source located in the CDA operations room	1 (rack)
<u>S-Band Receiver</u>		
3A1	Low noise pre-amplifier mounted in the vertex room behind reflector	(unit)
3A2	Down-converter, Dual local oscillator and Performance monitor up-converter, mounted in rack at azimuth deck equipment room	(unit)

Table 6-5 (continued)

<u>S-Band Receiver</u> (continued)		
3A3	IF amplifier, multi-coupler, remote control performance monitor IF amplifier and real-time data processing unit located in CDA operations room and mounted in separate rack	1 (rack)
<u>Antenna Main Cable Terminal</u>		
4A1	RF cable terminal	(unit)
4A2	Control and monitor cable terminal located in antenna foundation room	(unit)
<u>S-Band Transmitter</u>		
5A1	Up-Converter, IPA, power amplifier, coax switch, directional coupler and dummy load, etc., mounted in rack at azimuth deck equipment room	(unit)
5A2	Remote control and display located in CDA operations room and mounted in rack	1 (rack)
<u>Telemetry Receiver</u>		
6A1	Telemetry receiver, discriminator located in CDA operations room	1 (rack)
6A2	VHF receiving antenna, pre-amplifier located in outside building	
<u>Command Encoder</u>		
7A1	Command encoder #1	1 (rack)
7A2	Command encoder #2 located in CDA operations room	1 (rack)
7A3A1	Command verification receiver located in azimuth deck equipment room	(unit)

Table 6-5 (continued)

<u>Command Encoder (continued)</u>		
7A3A2	Command verification demodulator located in CDA operations room	
8A1	Synchronous controller #1 located in CDA operations room	1 (rack)
	ATS sync controller, OGO encoder and PCM/DHE located in operations building	3 (racks)
<u>Command Modulator</u>		
9A1	S-band command/WEFAX modulator located in CDA operations room	1 (rack)
<u>Synchronizer/Data Buffer</u>		
10A1	Tape deck, CPA, core	1 (rack)
10A2	Counter, scope, array, VCO	1 (rack)
10A3	Core, array, 2 ϕ mod.	1 (rack)
10A4	4 ϕ mod., demod., de-mux	1 (rack)
10A5	TTY ASR 35	
10A6	EISC photo recorder located in CDA operations room	3 (racks)
<u>Trilateration Ranging</u>		
11A1	Trilateration ranging	1 (rack)
11A2	Trilateration ranging	1 (rack)
<u>Data Collection System Equipment</u>		
12A1	DCS equipment	1 (rack)

Table 6-5 (continued)

<u>Data Collection System Equipment (continued)</u>		
12A2	DCS Equipment	1 (rack)
12A3	DCS equipment	1 (rack)
12A4	DCS equipment	1 (rack)
12A5	DCS equipment	1 (rack)
12A6	DCS equipment	1 (rack)
12A7	DCS equipment	1 (rack)
12A8	DCS equipment (UHF receiving antenna)	
<u>Pulse Code Modulation/Data Handling Equipment</u>		
13A1	PCM/DHE #1	1 (rack)
13A2	PCM/DHE #2	1 (rack)
<u>Master Control Console</u>		
14A1	MCC	1 (rack)
14A2	MCC	1 (rack)
14A3	MCC	1 (rack)
<u>Time and Frequency Standard</u>		
15A1	Time and frequency standard located in CDA operations room	1 (rack)
<u>Systems Analyzer</u>		
16A1	Systems analyzer located in CDA operations room	1 (rack)
<u>Station Alignment and Calibration</u>		
17A1	Station alignment and calibration azimuth equipment room or apex	1 (rack)
17A2	Station alignment and calibration located in CDA operations room	1 (rack)
<u>Station Events</u>		
18A1	Station events commutator and stretched video modem located in CDA operations room	1 (rack)

Table 6-5 (continued)

<u>Suitland Interface</u>		
19A1	Suitland interface equipment located in CDA operations room	1 (rack)
<u>WEFAX Monitor</u>		
20A1	WEFAX Monitor	(unit)
<u>CDA Main Cable Terminal</u>		
21A1	CDA main cable terminal	(unit)
21A2	CDA control and monitor cable terminal	(unit)
<u>Grid Interface</u>		
22A1	Grid interface	1 (rack)
22A2	Grid interface	1 (rack)
CDA STATION B		
1B4	Antenna control and display	1 (rack)
2B3	Parametric amplifier remote control, display, noise source	1 (rack)
3B3	S-band receiver remote control multi-coupler	1 (rack)
5B2	S-band transmitter remote control combiner	1 (rack)
6B1	Telemetry receiver	1 (rack)
7B1	Command encoder	1 (rack)
8B1	Synchronous controller	1 (rack)
9B1	S-band command/WEFAX modulator	1 (rack)
10B1	Synchronizer/Data buffer	1 (rack)

Table 6-5 (continued)

10B2	Synchronizer/Data buffer	1 (rack)
10B3	Synchronizer/Data buffer	1 (rack)
10B4	Synchronizer/Data buffer	1 (rack)
10B5	TTY ASR 35	1 (rack space)
11B1	Trilateration ranging	1 (rack)
11B2	Trilateration ranging	1 (rack)
12B1	DCS equipment	1 (rack)
12B2	DCS equipment	1 (rack)
12B3	DCS equipment	1 (rack)
12B4	DCS equipment	1 (rack)
12B5	DCS equipment	1 (rack)
12B6	DCS equipment	1 (rack)
12B7	DCS equipment	1 (rack)
13B1	PCM/DHE	1 (rack)
14B1	Master control console	1 (rack)
14B2	Master control console	1 (rack)
16B1	Systems analyzer	1 (rack)
17B1	Station alignment and calibration	1 (rack)
17B2	Station alignment and calibration	1 (rack)
19B1	Suitland interface	1 (rack)
22B1	Grid interface	1 (rack)

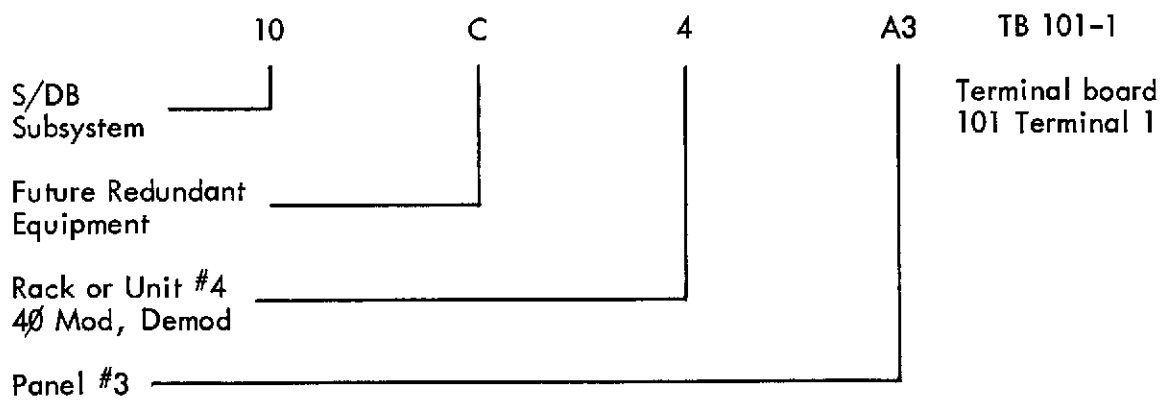
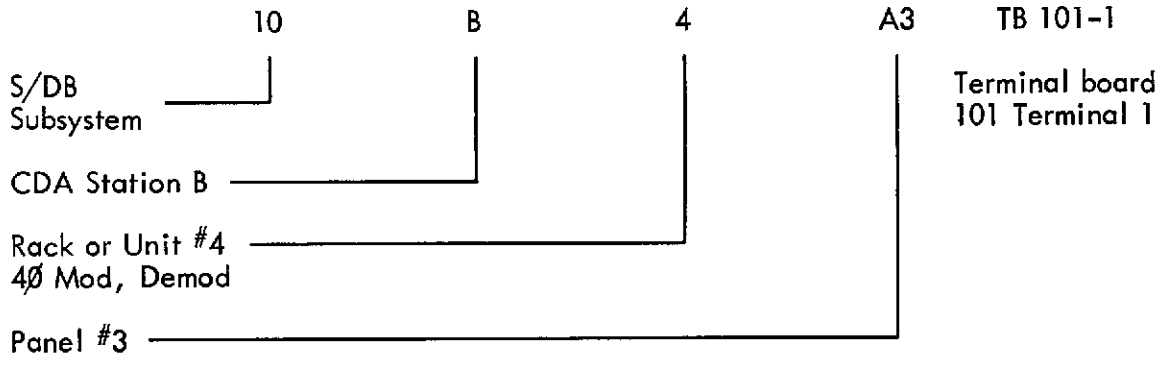
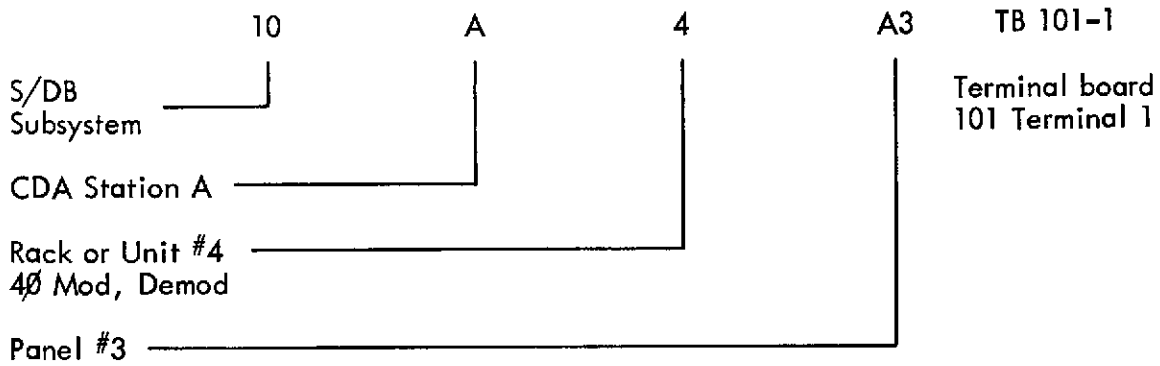

This system is utilized for all subsystems and is reflected on all interface drawings.

Figure 6-7. Typical Examples of Rack Numbering System

Rack type	EMCOR SFR 728A
Rack color	Federal standard 595-24172
Panel color	Federal standard 595-26555
Panel Lettering	Federal standard 595-27038
Rack Height	85 7/8 inches
Rack width	25 1/16 inches
Panel width	Standard 19-inch panels
Rack depth	30 inches

A removable pontoon base is provided as an integral part of each frame assembly. The overall height indicated above, includes the height of the 3-inch pontoon base. The top and bottom of the pontoon base is open in order to provide ventilation through the bottom of the frame enclosure. The front of the pontoon base is recessed 1/2 inch from the front of the frame enclosure.

6.3.5 MASTER CONTROL CONSOLE (MCC)

The MCC indicated in Figure 6-8, has been developed to provide two central locations for monitoring, supervising, and coordinating the ground station activities.

6.4 S-BAND ANTENNA

The S-band antenna subsystem consists of a pedestal with a support structure and counter-weight on a special foundation, an antenna with a reflector and feed system, servo and remote controls, and auxiliary equipment (power, control cable, etc.).

The antenna pedestal structure features a wheel and plate friction azimuth drive. The four supporting wheels roll on steel bearing plates that are mounted on the top of a reinforced concrete foundation. Each of the wheels are 24 inches in diameter and has a nominal width of 5 inches.

The structure is an elevation-over-azimuth space frame structure. The angle control system provides for remote control of the antenna and utilizes solid

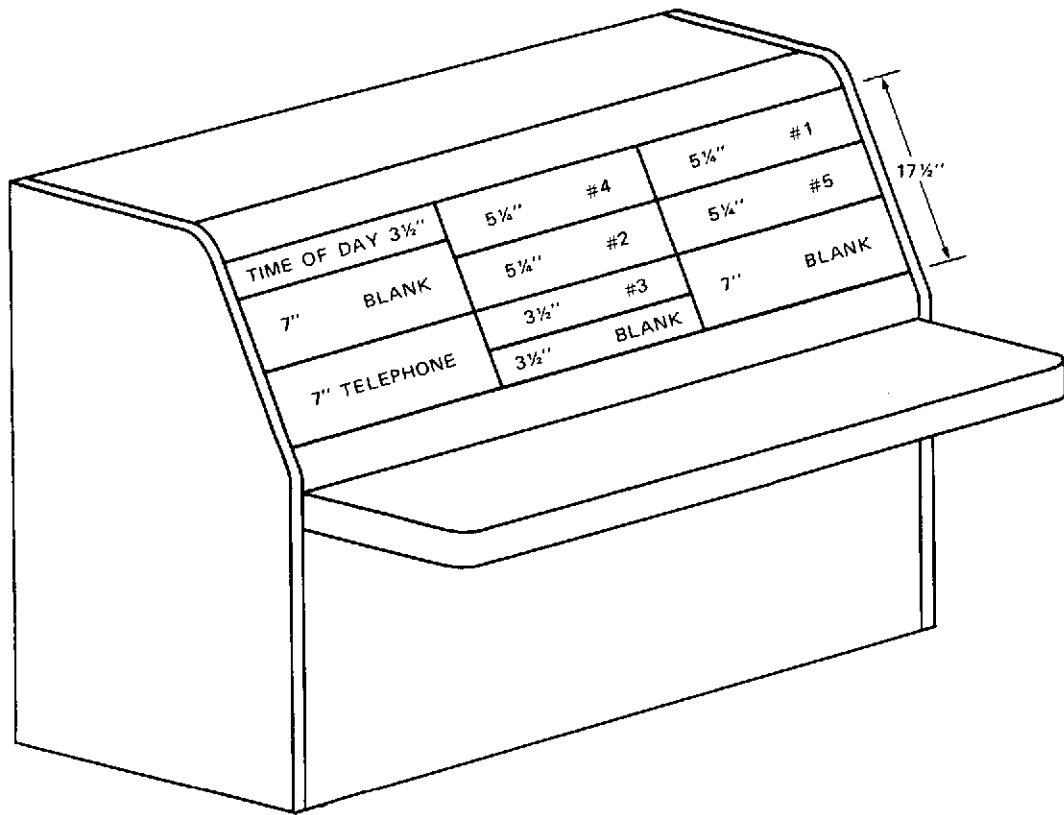

Figure 6-8. Master Control Console

state electronic drives with two 5-horsepower motors in azimuth and one 20-horsepower motor in elevation.

The horn is a circular multichoked horn which feeds the polarizer and is driven remotely for polarization control. The output of the polarizer feeds an isolator (diplexer) which provides protection to the receiver from the transmitter and other out-of-band noise. The antenna structure shown in Figure 6-9, and the antenna characteristics are summarized in Table 6-6.

6.4.1 REFLECTOR ASSEMBLY

The reflector assembly consists of the reflector surface, the reflector back-up structure, vertex equipment room, the reflector support structure, and the elevation drive.

The reflector surface is formed from aluminum panels forming a paraboloid 60 feet in diameter. The reflector back-up structure consists of 32 identical and equally spaced steel radial ribs that establish structural hardpoints to which the surface panels are mounted.

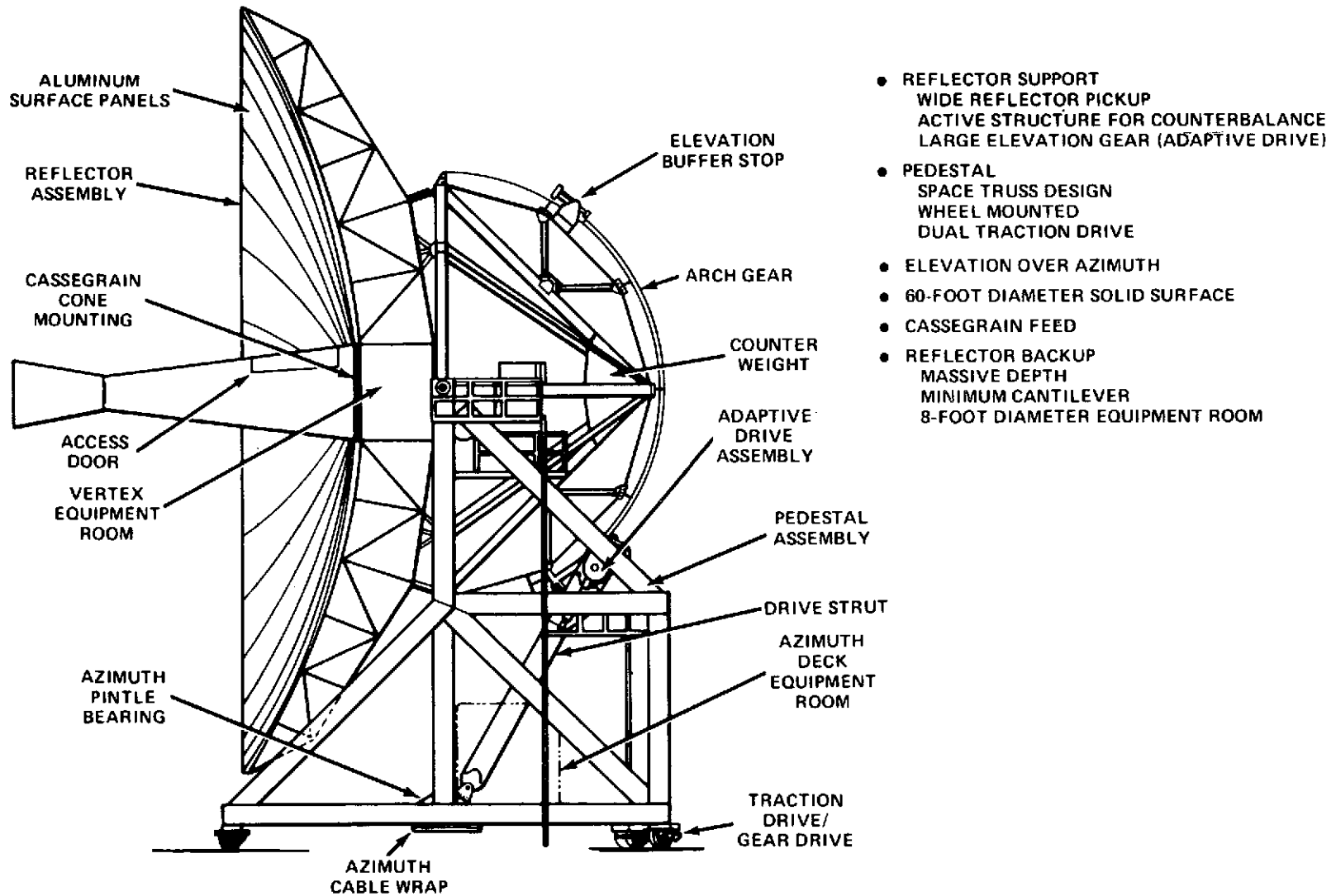

Figure 6-9. Antenna Structure, Side View

Table 6-6

S-Band Antenna Characteristics

Reflector diameter	60-ft (solid surface)
Feed	Cassegrain
Angular travel: elevation	-5 to +95°
azimuth	+200°
Transmit freq. band	1670 to 1700 MHz
Receive freq. band	2020 to 2040 MHz
Antenna gain	47 db
Polarization	Rotatable linear
Noise temperature	70° K
Reflector surface accuracy	0.040 - inch rms
Structure weight	140,000 pounds
Transmit power capability	2.5-kw cw 5.0-kw peak
Operational - wind	60 mph
Survival - wind	120 mph

The cylindrical vertex equipment room is a primary structural element of the reflector back-up structure. A Cassegrainian feed cone is interfaced at one end, the reflector back-up structure interfaces at the sides, and the reflector support structure interfaces at the end opposite the feed mounting ring.

The antenna is balanced through the use of a poured concrete counter weight which is used to counter balance the majority of the antenna unbalance. The remainder of the unbalance is removed by the installation of 200 and 100-lb steel plates.

A hatch in the feed cone provides access to the reflector surface. The panel construction is such that it supports a man (300 lbs per shoe) carrying equipment over the entire surface area. An additional hatch is also provided on the reflector surface.

6.5 PARAMETRIC AMPLIFIER

The parametric amplifier subsystem shown in Figure 6-10 is designed to amplify signals in the 1635-to-1735-MHz frequency range. The amplifier has three stages, with the third stage located at the ambient temperature. The amplifiers are fixed-tuned, and provide a minimum overall instantaneous 1-db bandwidth of 100 MHz, with a minimum overall gain of 30 db. The subsystem uses all solid state components including the pump sources. Each stage has an individual pump power control circuit which allows control of each stage at the remote control panel. A closed cycle type of refrigeration subsystem provides cryogenic cooling. Salient features of the cooled parametric amplifier subsystem are:

Operational bandwidth	1635-to-1735 MHz
Gain	30 db (min)
Instantaneous bandwidth	100 MHz (1 db)
Noise temperature	30° K
Tuning	Not required

6.5.1 CONTROL AND MONITOR PANELS

The control and monitor panels are packaged as three separate panels consisting of (1) refrigeration control panel, (2) paramp control panel, and (3) test monitor panel.

The refrigeration control panel contains elapsed time meters, refrigeration on/off power control, compressor on/off power control, refrigerator temperature, vacuum status, and the enclosure pressure.

The paramp control panel contains a display of the pump enclosure temperature, pump power, bias current, and bias voltage for the three amplifier stages, bias voltage adjust, gain adjust, and the power on/off control.

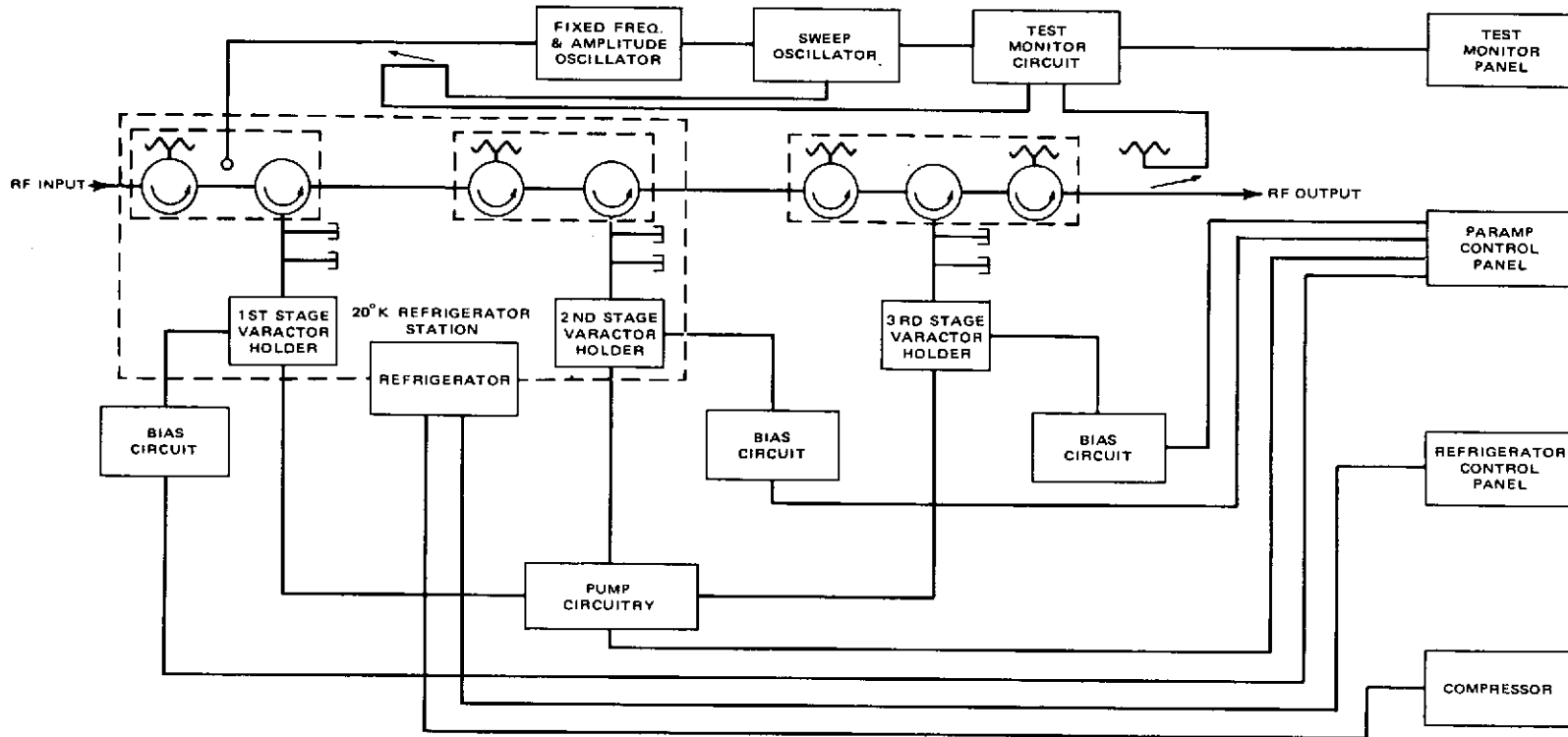

Figure 6-10. Parametric Amplifier Subsystem Block Diagram

The test monitor panel contains a gain-bandwidth (response) display, a noise temperature monitor display, and a power on/off control switch.

6.6 S-BAND RECEIVER

The S-band receiver subsystem consists of a RF pre-amplifier located in the vertex equipment room behind the antenna reflector, a down-converter, an up-converter and dual local oscillator assemblies located in the antenna azimuth deck equipment room. IF amplifier and distribution and remote control panels are located in the operations building.

As indicated in Figure 6-11, the input signals are passed through an input circulator and a 20-db directional coupler. The directional coupler may be used to insert the performance monitor test signals into the pre-amplifier input at signal levels from approximately -48 to -98 dbm. The pre-amplifier, with characteristics listed in Table 6-7, amplifies the input signal and then interfaces it with the down-converter by 60 feet of interface cable. The cable is protected against any VSWR mismatch by the circulators at both ends of the cable. The solid state down-converter with a local oscillator injection frequency of 1611.6 MHz then translates the received frequency band from 1.666 to 1.698 GHz to a band of frequencies from 54.4 to 86.4 MHz. The down-converter characteristics are listed in Table 6-8.

The output signals from the down-converter are fed through approximately 600 feet of 50-ohm cable to the operations building. Within the building the signals are further amplified, and then converted by a second local oscillator to the correct intermediate frequency and distributed through a multicoupler to the various subsystems. The wideband VISSR data, which are at the correct intermediate frequency, are fed directly to a 3:1 multicoupler for distribution.

The performance monitor up-converter, which is located in the azimuth deck equipment room, provides the necessary frequency translation for the 54.4-to-86.4-MHz IF band to a frequency range from 1.698 GHz. The up-converter electrical characteristics are:

Input frequency range	54.4 to 86.4 MHz
Input level	-14.2 to -64.2 dbm
Local oscillator input frequency	1611.6 MHz at +10 dbm
Input impedance	50 ohms

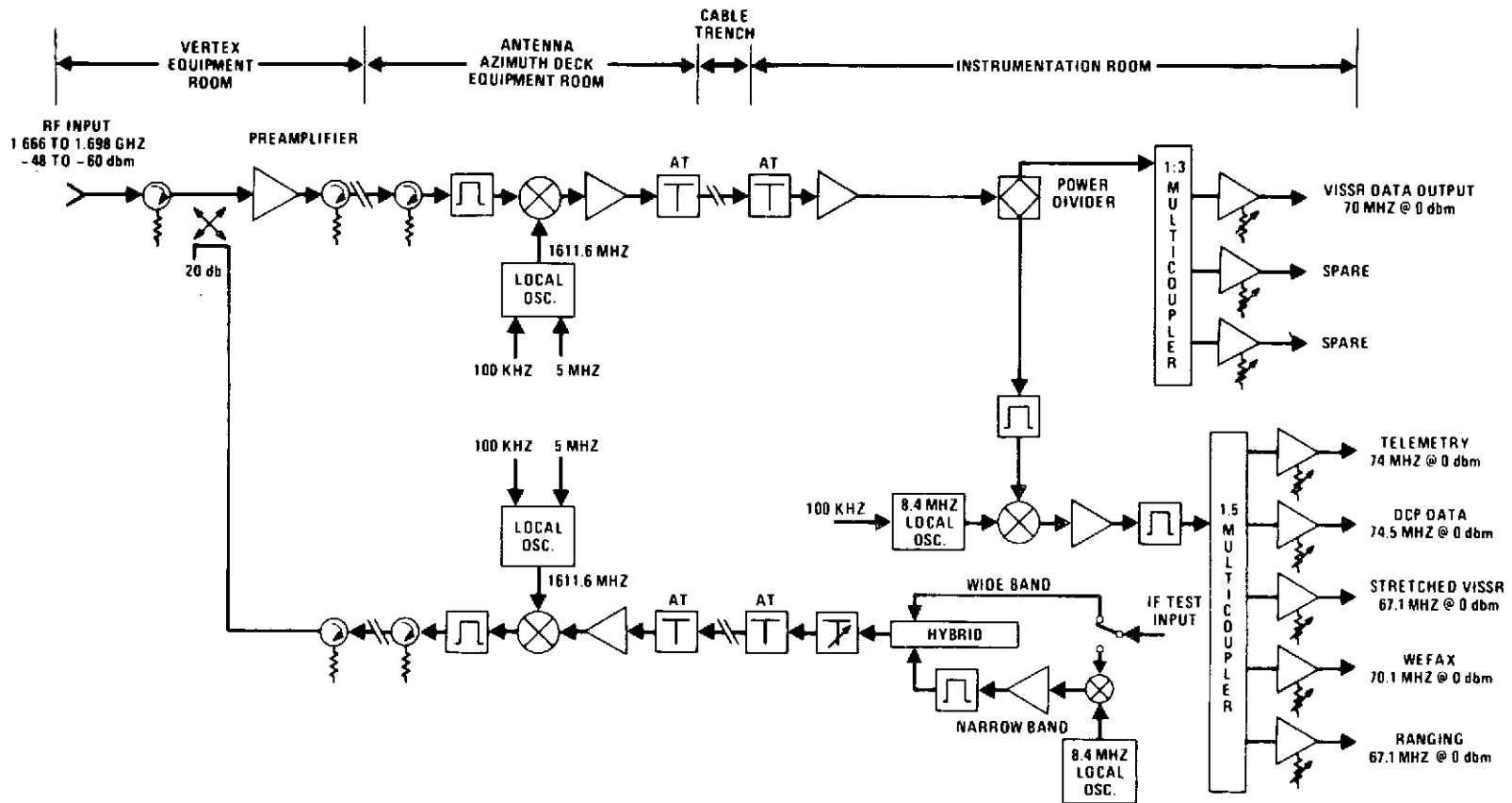

Figure 6-11. S-Band Receiver Functional Diagram

Table 6-7

Pre-Amplifier Characteristics

Frequency range	1.666 to 1.698 GHz
Input level	-48 to -60 dbm
Gain	27 db \pm 0.5 db
Input and output impedance	50 ohms
Noise figure	9 db
Performance monitor input frequency	1.666 to 1.698 GHz
VSWR	1.1:1

Table 6-8

Down-Converter Characteristics

Input frequency range	1.666 to 1.698 GHz
Input level	-28.5 to -40.5 dbm
Gain RF to IF	13 to 25 db \pm 0.5 db
Local oscillator input frequency	1611.6 MHz at +10 dbm
Input impedance	50 ohms
VSWR	1.1:1
Output impedance	50 ohms
IF output band	54.4 to 86.4 MHz
IF output range	12 db continuously variable

VSWR	1.1:1
Output impedance	50 ohms
VSWR	1.1:1
RF output band	1.666 to 1.698 GHz
Output level	-21 to -70 dbm

The performance monitor equipment is used in conjunction with other test instruments to measure the receive subsystem amplitude response and phase linearity on an IF-to-IF back-to-back basis.

6.7 TELEMETRY AND COMMAND

The telemetry function of the telemetry and command subsystem is required to provide command verification prior to command execution; receiving sun sensor, earth sensor and nutation sensor data, and monitoring spacecraft data for diagnostic analysis during the mission. The command function is required to provide a capability to command various spacecraft functions during the life of the satellite.

A VHF link is used for the telemetry and command functions during the transfer orbit of the spacecraft. When the spacecraft is positioned in a synchronous orbit; the telemetry and command functions operate through an S-band link, with the VHF link as a backup.

6.7.1 TELEMETRY RECEIVER

The telemetry receiver is capable of accepting either VHF telemetry or S-band telemetry.

The salient features of the telemetry receiver are:

Range	105-to-155 MHz, plus fixed frequency of 74 MHz
IF bandwidths	1st IF section 4.0 MHz 2nd IF section 30, 50, 100, 300, 500, 750, 1000, 1500 or 2000 kHz
Phase demodulators	PM or synchronous AM

6.7.2 PULSE CODE MODULATION DATA HANDLING EQUIPMENT (PCM-DHE)

The PCM-DHE will be used as the PCM telemetry decommutation system for SMS. The telemetry data will consist of parameters specifying spacecraft performance, and solar environmental data.

Modular capability for expansion to increase the distribution and display and capability for responding to a wide range of bit rates and telemetry formats are built-in features of the PCM-DHE.

The major PCM-DHE equipment include:

- Bit synchronizer & signal conditioner
- Group synchronizer & programmer (data decommutator)
- Data distribution unit
- Outputs & displays
- Test equipment

The PCM-DHE subsystem will condition incoming PCM signals, generate re-constructed PCM bit streams, accept digital synchronization codes, accept and decommutate variable word lengths, prepare data for insertion into specified peripheral equipment, and provide for quick-look and checkout monitoring of system performance.

Salient features of PCM-DHE are:

Input code format	Serial PCM data in codes NRZC, NRZM, bi-polar 50-percent RZ, SOC, SOM and SOS.
Bit rates	PCM data 10 to 1,000,000 bps
Input signal level (serial PCM)	0.5-to-30 volts p-p
Bit jitter	Noncumulative ± 20 -percent displacement of bit period from nominal position and at jitter rates as high as bit rates.
Displays	4 octal, 2 decimal, 2 binary, 1 digital/analog printer

6.7.3 PCM TELEMETRY DATA

A total of 64 words is contained in the SMS main frame telemetry. The main frame consists of 46 analog words, 16 digital words, and two words which contain submultiplexers of 32 and 64 words each. The main frame digital words include two words for frame synchronization, one word for normal and dwell-mode indication and subframe identification, and one word for command verification. The 64-channel submultiplexer consists entirely of analog words. The 32-channel submultiplexer consists of 28 analog and 4 digital words. The PCM telemetry data have the following characteristics:

Bit rate	187.99 bps
Dwell mode operation	Readout is 64 times normal rate
Frame rates	Mainframe - 3.06 seconds/frame 32-channel submultiplexer - 1.63 minutes/ subframe 64-channel submultiplexer - 3.26 minutes/ subframe
Frame sync	18 bits
Carrier modulation	Biphase level PCM/PM
Data format	
Main Frame	64 words
Sub frame	64 words on channel 28 32 words on channel 60
Word length	9 bits
Frame length	576 bits

6.7.4 REAL-TIME DATA UNIT (RTDU)

The real-time data unit (RTDU) is used to convert analog telemetry functions into formats suitable for transmission over the NASCOM network. This equipment performs the following functions:

- Demodulates the ABM, APS, execute verify, and nutation signals and relays this information to MSOCC.

- Demodulates the sun and earth sensor signals, measures sun interval, earth interval, time between leading edge of sun and leading edge of earth and satellite spin period and relays this data to MSOCC. Figure 6-12 illustrates the components of the RTDU.

The RTDU consists of two distinct assemblies. One assembly contains the attitude data unit and nutation control unit. The second assembly contains the FM data multiplexer.

6.7.4.1 General Description

The real-time data unit accepts real-time satellite data within the spectrums of IRIG channels 12 and B from the telemetry receiver. Each channel has a single tone which shifts, on a priority basis, among preassigned frequencies.

Data within the channel-12 bandwidth are used to monitor ABM firing, satellite nutation, and operation of the APS. In addition, should the satellite ANC system fail, the nutation data and execute verify data can be used to manually correct satellite nutation through the ground station synchronous controller. The following priorities apply to satellite transmissions: first, ABM; second, APS; third, nutation.

The ABM signal occurs only once, during which time no APS or nutation data are necessary or available. The APS signal occurs only during the operation of the ANC system. The nutation signal, which is true FM, is available continuously. All three signals are prepared for transmission to MSOCC as shown in Figure 6-12. In addition, the execute verify and nutation signals are sent to the synchronous controller.

Data within the channel-B bandwidth contain the execute verify signal, to be used as mentioned above, attitude data in the form of earth and sun-sensor signals, and an idle signal which is present when the others are not active. The following priorities apply to satellite transmissions: first, sun sensor; second, execute verify; third, earth sensor; fourth, idle.

The execute verify signal is prepared for transmission to MSOCC and the attitude signals (earth and sun-sensor signals) are used by the digital section for time interval measurement. All three signals are sent to the synchronous controller.

The digital section of the RTDU makes appropriate time interval measurements, and generates a serial PCM stream for transmission by the FM data multiplexer.

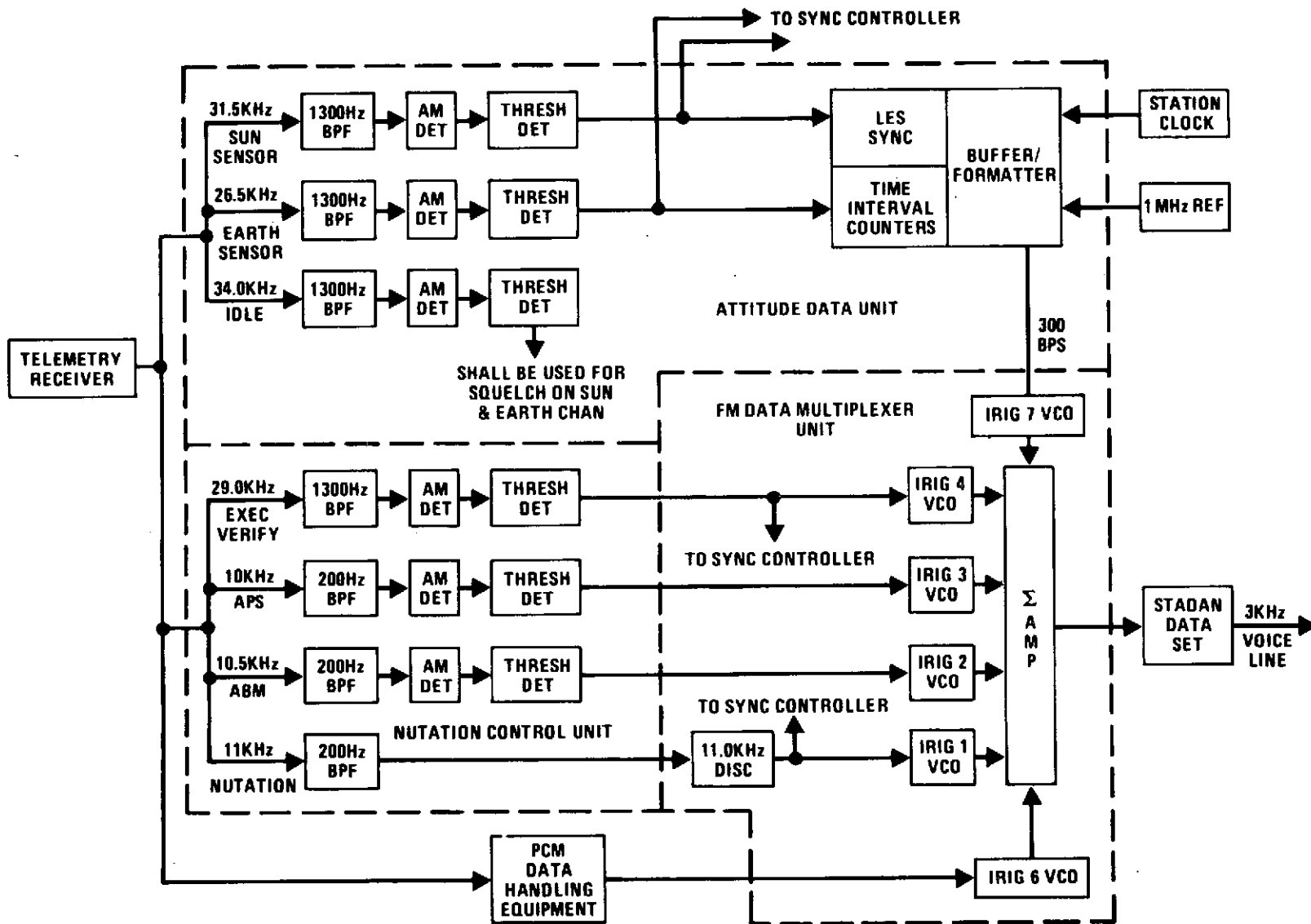

Figure 6-12. Real-Time Data Unit Block Diagram

The execute verify, APS, ABM, nutation data, PCM and 300-bps attitude data are FM multiplexed and sent by a 3-kHz voice data line to MSOCC.

6.7.5 COMMAND ENCODER

The command encoder (Figure 6-13) accepts command data from any of three sources; (1) manual data input switches, (2) preprogrammed command switches, and (3) parallel input data from a computer. The encoder accepts an 8-bit command word and develops the selected address, sync pattern, and timing bits. All commands entered are displayed by a command data display located on the front of the equipment.

A 30-bit BCD time interface is used to record on a digital printer all commands transmitted with the corresponding time of transmission.

The command encoder consists of one electronic equipment rack and contains all equipment necessary to monitor, operate, and control the encoder. These include the following: (1) manual data input controls, (2) operational controls, (3) displays, (4) encoder electronics, (5) digital printer, (6) frequency generator and modulator, (7) frequency detector and comparitor, (8) output amplifier, and (9) power supplies.

The command encoder interfaces with the following CDA station equipment:

- Time-code generator
- PCM data handling equipment
- Synchronous controller
- Synchronizer/data buffer
- Command modulator

After transmission of command data, a "holding" signal is generated with no continuity loss of the bit rate modulation. The command encoder outputs the holding tone indefinitely until it is cleared, or until the execute tone is gated out. After the execute tone is generated, the encoder continues to generate the "holding" signal in anticipation of another execute tone until the command encoder is cleared. The command encoder can be cleared from either the synchronous controller or the encoder control panel. Execute tones can be gated out either by the synchronous controller or the S/DB. The execute tone is either amplitude modulated or unmodulated, as selected by the operator of the command encoder.

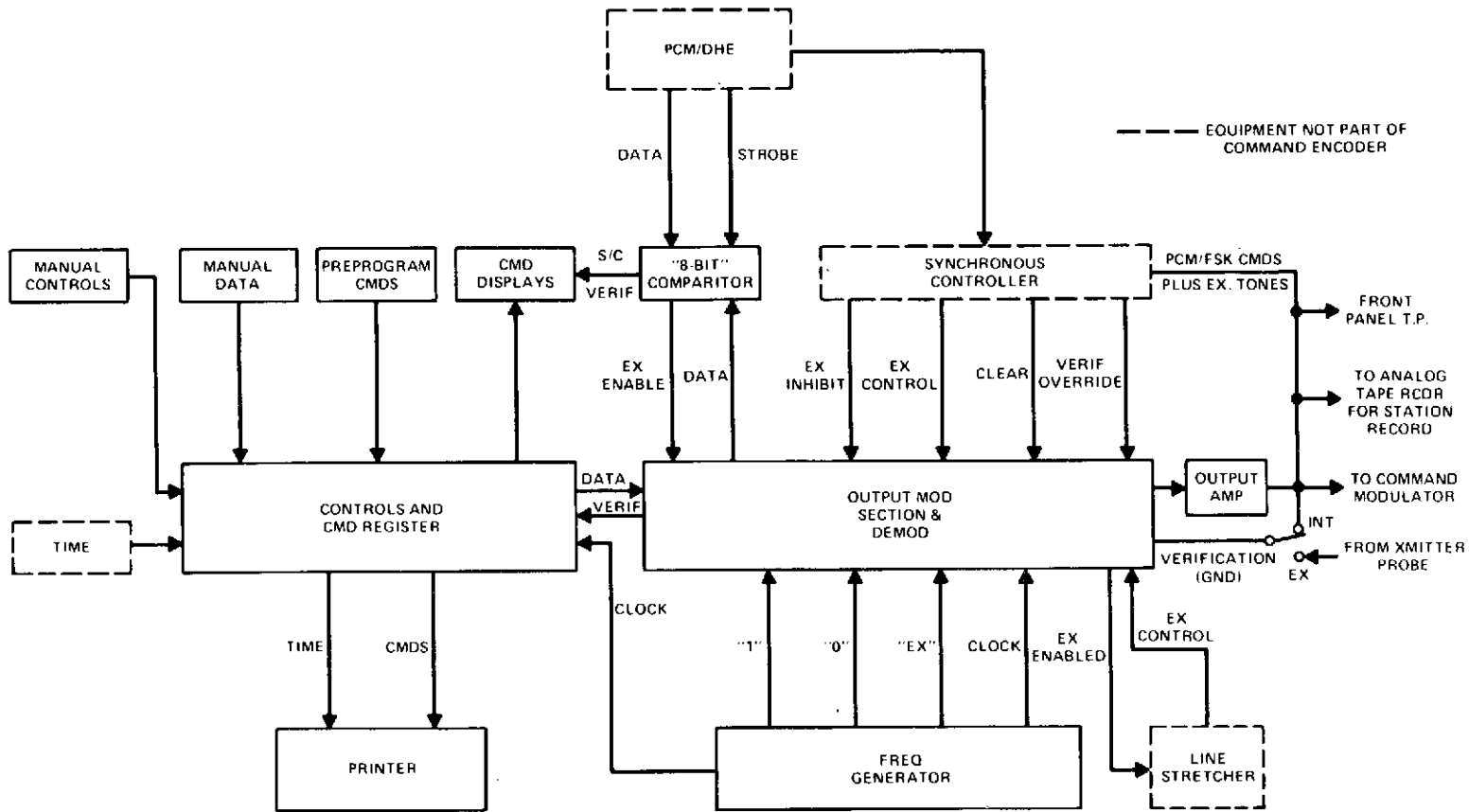

Figure 6-13. Command Encoder Block Diagram

As a command is being generated it is coupled back to a demodulator in the encoder from either the output amplifier or the transmitter probe. A bit-by-bit ground verification is performed on all command data. The resulting demodulated data are displayed.

An "8-bit" telemetry verification comparator checks the command data against the data returned from the PCM data handling equipment. The results of the telemetry verification is displayed. Circuitry within the encoder inhibits the generation of the execute tone prior to successful telemetry verification; however, this feature may be overridden by either the synchronous controller or by manual control from the command encoder.

6.7.5.1 Command Message Format

The command message format consists of five parts: the introduction, word sync, address number, command number, and execute. The message is coded in non-return to zero (NRZ) format at a 128-Hz clock rate. The spacecraft command data that are generated by the command encoder at the CDA station are as follows:

Introduction	27 or more continuous zeros, i. e. data periods of zero tone
Word sync pattern	A "one" followed by a "zero"
Decoder address for each spacecraft decoder	8-bit binary word, MSB first
Command number	8-bit binary word, MSB first
Execute	Continuous execute tone. Duration is determined by the ground station sync controller.
Repetitive execute	A series of "zeros" are generated between each execute tone and after the final execute tone by the ground station command encoder.
Clear	The ground station command encoder generates tone interrupts of 325 ± 175 milliseconds to clear the spacecraft decoder
Carrier modulation	FSK/AM/PM

"1" FSK data tone	8.6 kHz \pm 0.01 percent amplitude modulated
"0" FSK data tone	7.4 kHz \pm 0.01 percent amplitude modulated
Execute tone	5.79 kHz \pm 0.01 percent modulated or unmodulated
Command message length	45 bits plus execute
Command bit rate	128 bps
Holding tone	"0" data tone, amplitude modulated
Command verification	Main frame telemetry readout of command number
Command capability	256 discrete commands
Bit sync	128-Hz sinusoidal waveform 50 percent AM on "1" and "0" tones

6.7.5.2 Pyrotechnic Commands

Two valid commands are required for satellite ordinance initiation. The first command is an "ENABLE" command which is paired with an "INHIBIT" command to restore the function to the inhibited state. The second command is the initiate command.

6.7.6 SYNCHRONOUS CONTROLLER

The synchronous controller subsystem is used to provide the necessary execute control to execute spacecraft commands. This is accomplished by supplying the correct pulse duration, pulse phasing, and number of pulses as required by the individual satellite subsystems or operation.

6.7.7 VHF ANTENNA

The VHF antenna at the CDA station consists of a crossed dipole configuration which has an 18-db receive and an 11-db transmit capability. Positioning of the antenna is a manual system with the control panel located in the operations building. The antenna has no automatic tracking capability.

6.7.7.1 VHF Transmitting Equipment

The VHF command transmitting capability is configured from transmitting equipment currently in use on other programs at the CDA station. There are two transmitters which are capable of PM modulation. One transmitter is used for commanding the NOAA polar orbiting spacecraft and has a maximum 2-kw capability. The other transmitter is used in the ATS WEFAX program and has a maximum capability of 5 kw.

6.7.7.2 VHF Receiving Equipment

The VHF receiving subsystem is capable of receiving and demodulating the telemetry data at the S-band IF of 74 MHz or at VHF in the range of 136 MHz. It has two channels for diversity reception at VHF if required.

6.8 S-BAND TRANSMITTER

The S-band transmitter subsystem consists of a power amplifier, frequency up-converter and a performance monitor down-converter located in the antenna azimuth deck equipment room. A remote monitor and control panel are located within the operations building for operator control and monitoring.

The functional block diagram of the S-band transmitter is shown in Figure 6-14. The multiple IF input signals are combined and fed to an IF amplifier. The combined output is then sent to the antenna azimuth deck equipment room where signal up-conversion and amplification occur. Attenuation pads are provided at both ends of the interfacility cable to minimize the VSWR.

The power amplifier uses a Varian 4K5SL-1 model klystron. The klystron contains four cavities and is air cooled. The klystron is fixed tuned at 2030 MHz and provides a 1-db RF bandwidth of 10 MHz with a minimum saturated power output of 2 kw. If less power output is required for a particular operation, then the output can be controlled either by reduction of beam power or control of the RF drive level.

6.8.1 METERS AND CONTROLS

The power amplifier contains a complete set of operating controls, meters, and protective interlocks. The meters and controls, provided at the power amplifier, are as follows:

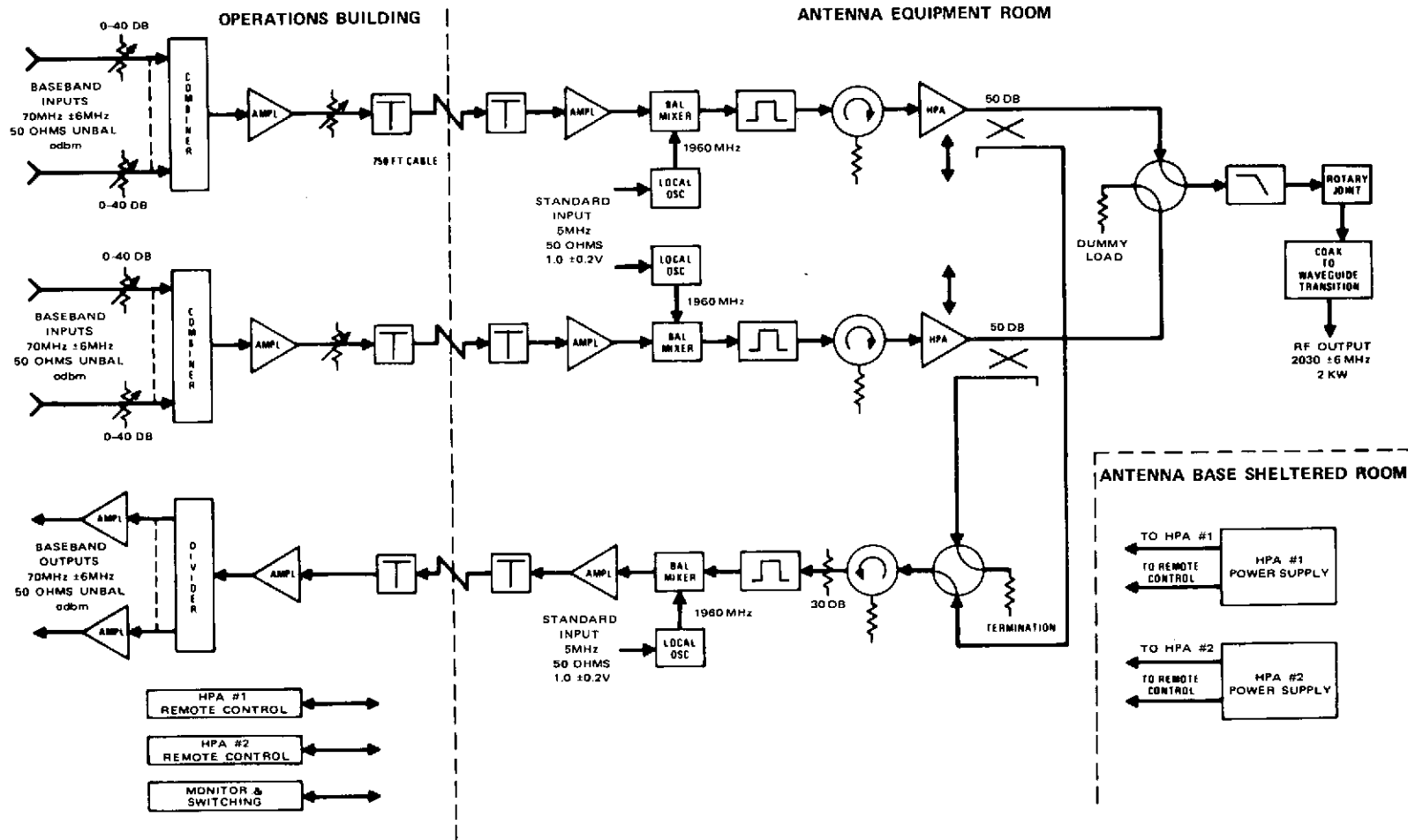

Figure 6-14. S-Band Transmitter Subsystem Block Diagram

Power amplifier meters

RF input power - forward

RF output power - forward

RF output power - reflected

Filament voltage

Filament current

Filament hours

Beam voltage

Beam current

Beam hours

Power amplifier controls

Main power, on-off

Air cooling power, on-off

Beam power, on-off

Beam voltage, on-off

Beam voltage adjust

Control power, on-off

Filament power, on-off

Filament voltage adjust

Input drive, higher/lower

HPA control, local/remote

Fault reset

Power amplifier controls (continued)

Low RF power output meter relay adjust

High reflected power meter relay adjust

High beam current meter relay adjust

Power amplifier displays

On line

Main power on

Time delay on

Beam voltage ready

Beam voltage, on/off

HPA control local/remote

Input drive, higher/lower

Low RF output

High reflected power

Low air flow

Beam current overload

Low filament current

High tube temperature

Interlocks

Remote panel controls and indicators

Beam voltage, on/off

Input drive control, 0-2 db

Remote panel controls and indicators (continued)

Standby/transmit switching and status

RF power output

Status and fault indicators

Fault reset

Audible alarm and disable switch

6.9 FREQUENCY AND TIMING STANDARD

The CDA station utilizes Loran-C for time and frequency. Loran-C is a hyperbolic grid radio navigation system administered by the United States Coast Guard. Currently, this navigation system is operational over much of the world.

The essential similarity between radio navigation and time/frequency systems is well known. In view of this, and to meet many time/frequency user needs, the United States Naval Observatory has been charged with responsibility for implementing and maintaining time services within the Loran-C system framework. When using stabilized, synchronized Loran-C transmissions, time/frequency measurements are directly traceable to the National Standards.

Loran-C navigation system properties that have major importance to time/frequency applications are:

- Stable groundwave propagation in the optimum, protected 90 to 110-kHz navigation band.
- Pulse-type transmissions allow separation of desired groundwave signals from interfering with skywave signals by time discrimination.
- Pulse transmissions occur in phase-coded groups to facilitate transmitter identification and to permit rejection of skywave and CW interference.
- All transmitters operate on the same nominal carrier frequency; inter-station interference is prevented by emission delay and cross-rate techniques.

An Austron Model 2000 C Loran-C receiver is used to receive and phase track Loran-C signals for time and frequency calibration and control, propagation study, and other purposes. When used to monitor the Loran-C groundwave, the Loran-C receiver permits time epoch determinations of sub-microsecond accuracy. Frequency measurements with an accuracy of one or two parts in 10^{12} are possible with one-day averaging.

6.9.1 LORAN-C SIGNAL TIMING; REFERENCE PULSES

Figure 6-15 shows idealized timing of signals in a typical synchronized Loran-C chain. The beginning of the first pulse of certain pulse groups emitted by the master station is on time relative to a second of Universal Time Clock (UTC), Naval Observatory (NO). Such a pulse is called a reference pulse, and the second of UTC (NO) with which it is coincident is called a null second.

When the Loran-C receiver is tracking properly, it generates pulses that are time-locked to the received Loran-C signal. These pulses form the principal output of the Loran-C receiver for timing purposes.

When the Loran-C receiver phase-gate pulses are time-locked to the received Loran-C signal, the phase-gate pulse that corresponds to a reference Loran-C pulse is delayed relative to the UTC null-second. This delay is called the total timing delay ($T^2 D$) which is composed of several factors, identified in the following paragraphs and shown in Figure 6-16.

- Emission Delay is the nominal delay that exists between emission of a signal from the master transmitter and the emission of the corresponding signal from a slave. When a Loran-C chain is operational, the actual emission delay is within 0.1 microsecond of nominal.
- Propagation Delay is the delay between emission of a signal at a transmitter and its arrival at a receiving site over a particular propagation path. For the groundwave, the coordinates of transmitting and monitoring sites may be used to predict delay with little uncertainty. For skywave timing, the data of Figure 6-17 may be employed to estimate a skywave correction for application to a groundwave signal for a particular skywave mode. Alternatively, a portable atomic clock may be used to transfer time from transmitter to receiver to establish propagation delay for groundwave or skywave by direct measurement.
- Receiver Delay is the delay that the signal undergoes between the antenna and the tracking detector circuits, corrected by approximately $1/4$ cycle for the delay between the beginning of the phase gate and the corresponding cycle zero-crossing (tracking point).

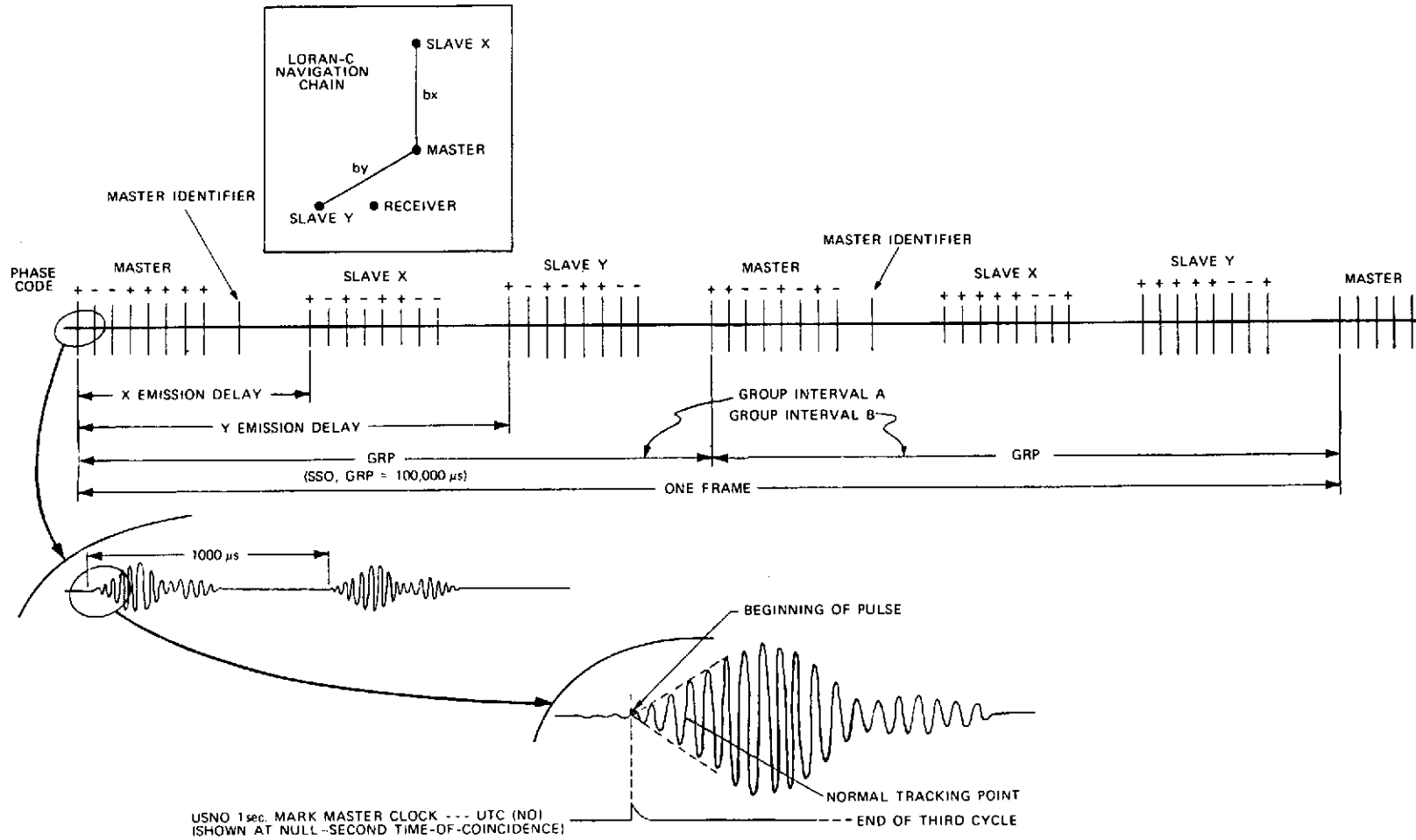

Figure 6-15. Timing of Loran-C Signals

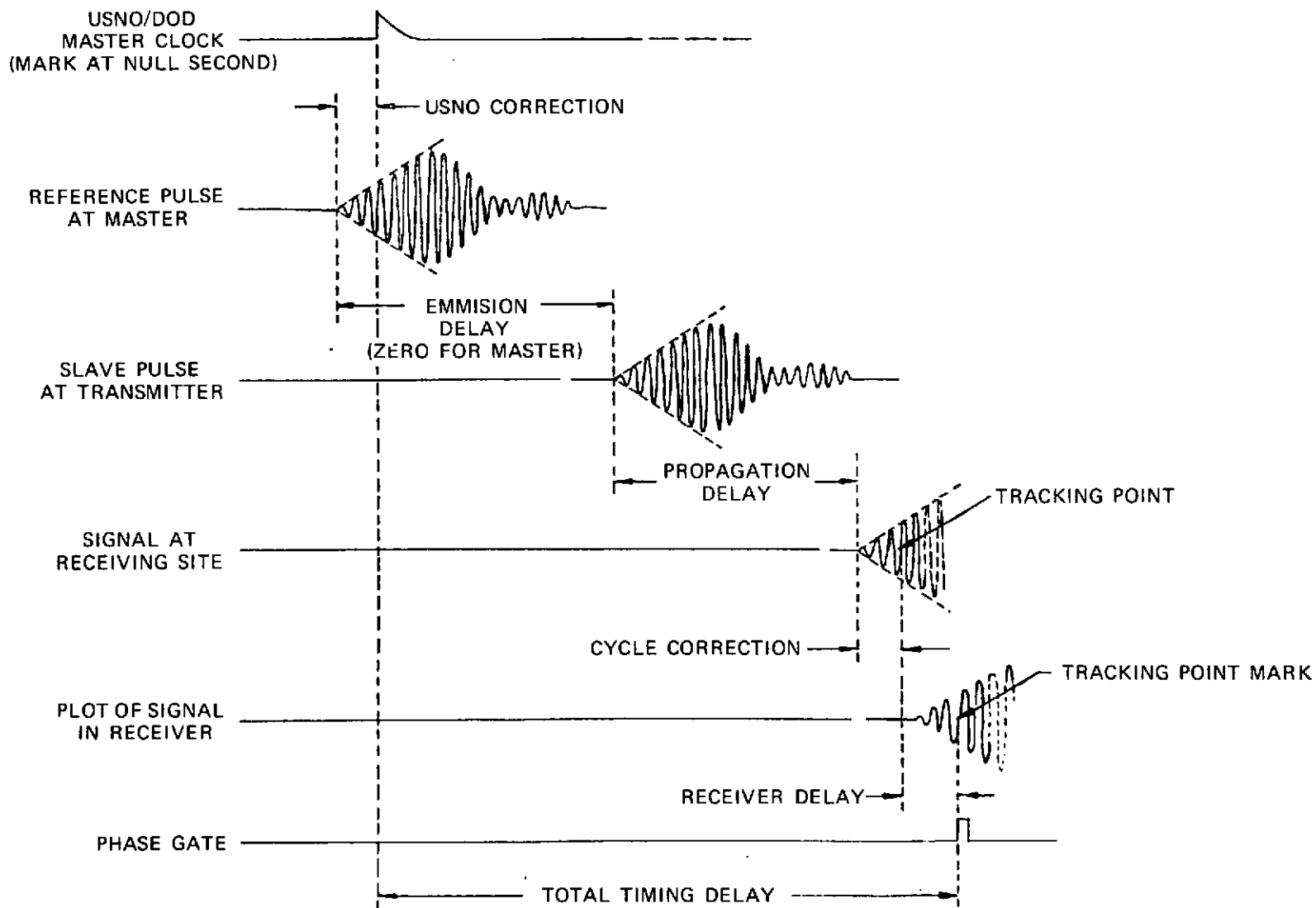

Figure 6-16. Factors in Total Timing Delay

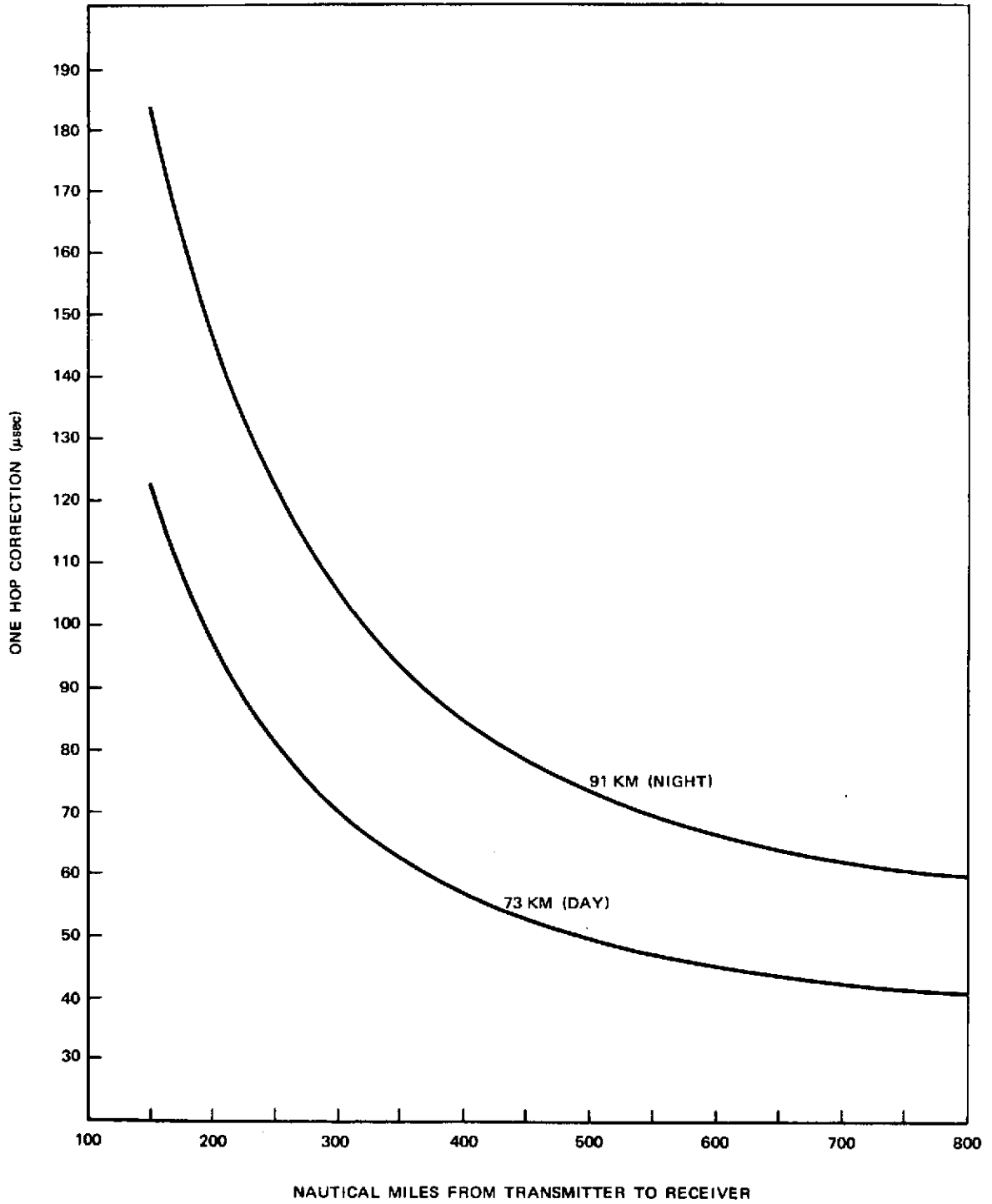

Figure 6-17. One Hop-Skywave Correction

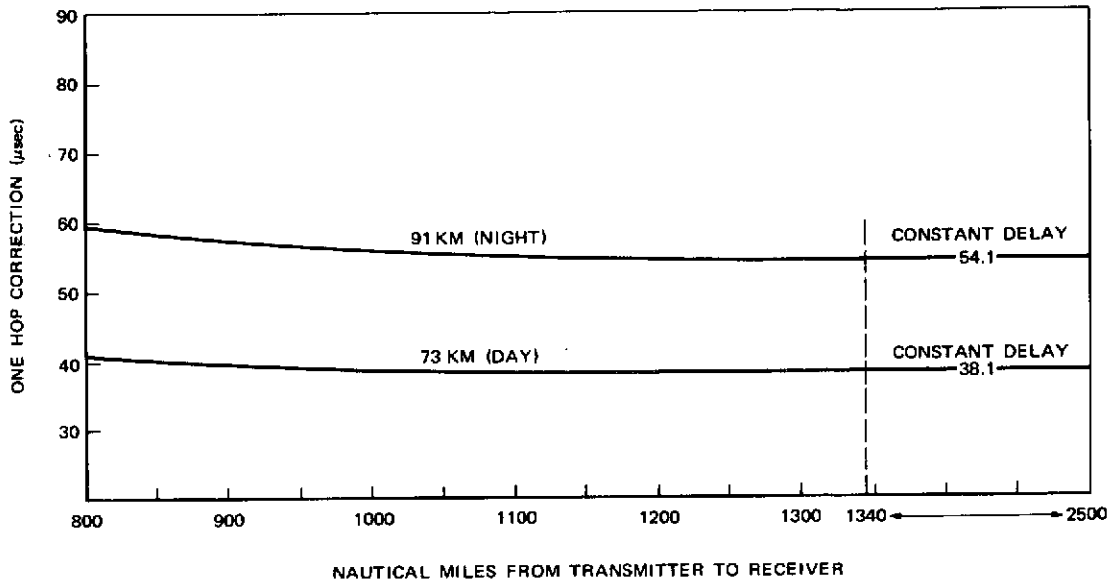

Figure 6-17. One-Hop Skywave Correction

- Cycle Correction**, the Loran-C reference pulse is nominally timed to begin on a second of UTC (NO). Because the signal pulse has essentially zero amplitude at the beginning, the phase gate is normally locked to the signal one or more cycles after the beginning of the pulse. Thus, to determine a standard cycle correction of 10, 20, 30, etc., microseconds, it is necessary to find the nominal delay between the beginning of the pulse and the tracking point. The Loran-C Receiver accomplishes this by using an auxiliary recorder to prepare a record of the waveform. Figure 6-18 shows an example of such a record. To show the tracking point or location of the phase gate relative to the signal, the input to the recorder is returned to zero when the phase gate and signal scanning gate are coincident. Intersection of the straight lines that approximate the ascending envelope of the signal indicates the beginning of the pulse; counting the whole number of cycles from the tracking point back to the beginning of the pulse, allowing ten microseconds per cycle, establishes the appropriate correction.

NOTE

Alignment of the envelope with the carrier isn't always exact; i.e., the intersection of the envelope lines of Figure 6-18 may not always occur exactly on an extrapolated zero-crossing of the carrier. Misalignment of carrier cycles and envelope in the signal as transmitted or dispersion in the propagation medium may account for this apparent misalignment. Nevertheless, these effects do not normally account for more than one-half cycle error, so that cycle identification may be accomplished easily.

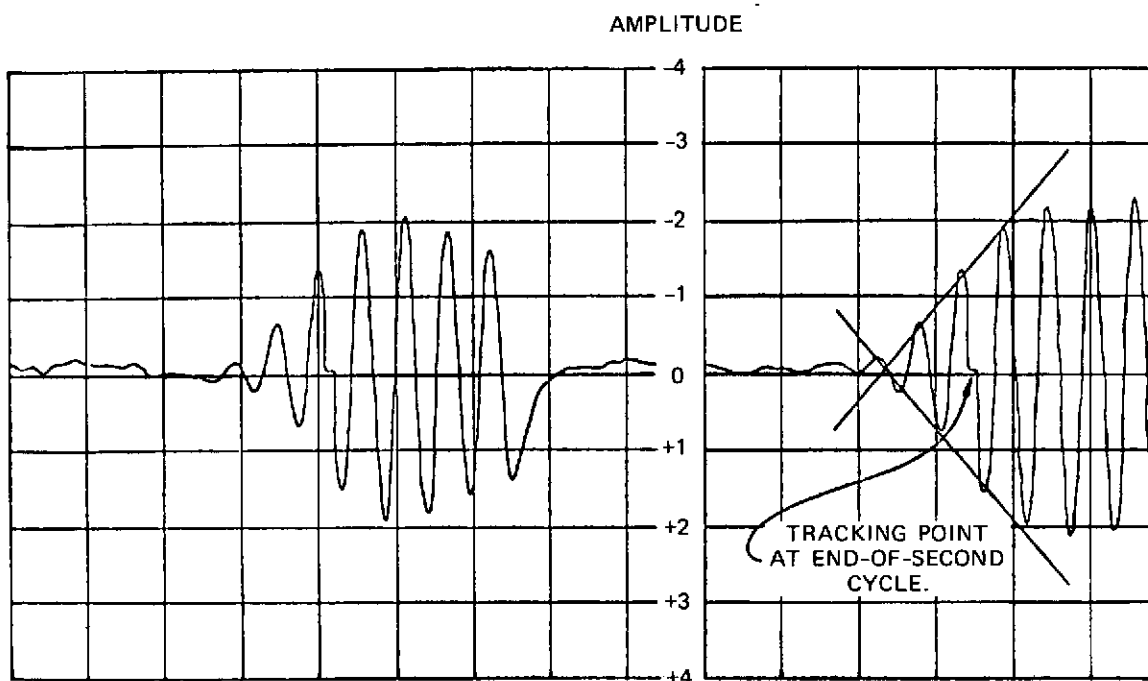

Figure 6-18. Typical Loran-C Waveform Record

- USNO Correction is a daily time correction that is published on a weekly basis by USNO. This correction relates the actual emission time of the reference pulse to UTC (NO). USNO Correction is always less than twenty-five microseconds, and has a resolution of 0.1 microsecond.

6.9.1.1 USNO Time-of-Coincidence (Null) Ephemeris

The Loran-C reference pulse may recur, depending on the specific Loran-C group repetition period of the chain, as often as once per second, or as infrequently as once in sixteen minutes. USNO has published tables that may be used to find Null Seconds of UTC (NO), to enable identifying reference pulses.

6.9.1.2 Loran-C Timing Worksheet

Worksheets have been developed as an aid to performing and permanently recording the computations that are required for Loran-C timing. Figure 6-19 shows an example of a worksheet that has been completed.

6.9.2 BASIC SYSTEM FOR MEASURING LOCAL TIME

Figures 6-20 and 6-21 show a basic system for measuring local time with the Loran-C receiver. It is assumed that the local clock in this system has been set within zero to ten milliseconds ahead of correct time by referring to WWV,

Chain Central Pacific

Period 59,600 μ sec

Station Upolu Point Lat _____ Long _____

Emission Delay 15971.8 μ sec

Receiver Model AUSTRON 2000 S/N 002

Receiver Delay 28.6 μ sec

Receiver Location: Lat 39° 05' 36" N Long 77° 08' 26" W

Propagation Distance 4142.0N miles

Groundwave Delay 25,626.2 μ sec

1. TIME OF COINCIDENCE (TOC)

1.1 Basic TOC	<u>09 06 20</u>	<u>09 11 18</u>	<u>09 16 16</u>	UTC
1.2 First TOC	<u>00 00 14</u>	<u>00 00 14</u>	<u>00 00 14</u>	UTC
1.3 TOC	<u>09 06 34</u>	<u>09 11 32</u>	<u>09 16 30</u>	UTC

2. TOTAL TIMING DELAY (T²D)

2.1 Emission Delay	<u>15971.8</u>	
2.2 Groundwave Delay	<u>25626.2</u>	
2.3 Skywave Correction	<u>108.2</u>	
2.4 Receiver Delay	<u>28.6</u>	
2.5 Cycle Correction	<u>30.0</u>	
2.6 USNO Correction	<u>5.0</u>	
2.7 T ² D	<u>41769.8</u>	μ sec
2.8 T ² D (Meas)	_____	
2.9 Local Time Error	_____	

Figure 6-19. Loran-C Timing Worksheet

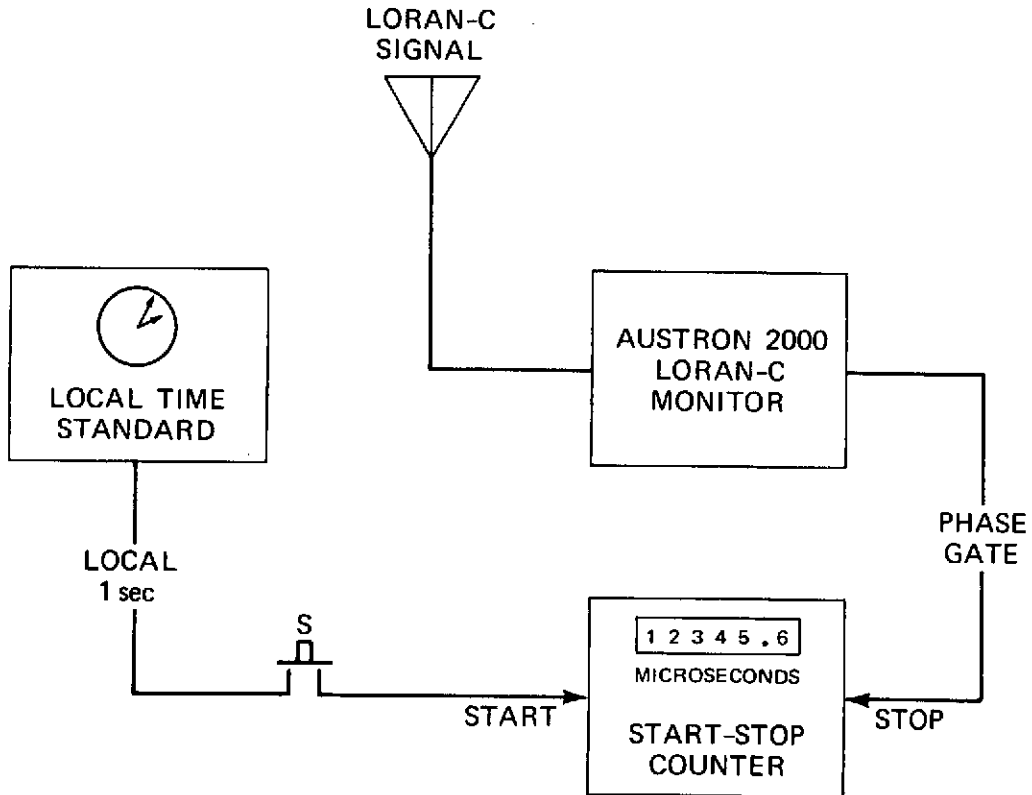

Figure 6-20. Basic System for Loran-C Timing

etc. Here, the operator uses the USNO time-of-coincidence (null) ephemeris tables and a timing worksheet to compute an upcoming null second. Less than a second before the null second, the operator closes switch S. Therefore, immediately following null second of local time, the start-stop counter starts accumulating time interval. The counter stops at the first subsequent phase-gate pulse from the Loran-C receiver. The counter reading, therefore, represents the measured total timing delay (T^2D meas); the operator then enters this quantity on the timing worksheet (2.7) for comparison to the computed value (2.6) to find the local time error (2.8).

6.9.3 MEASURING FREQUENCY

The frequency measurement of a local frequency standard is accomplished by two simple steps:

1. A phase tracking record is prepared using the signal radiated by a synchronized Loran-C transmitter. The record should cover a period that is appropriate to the desired measurement accuracy. For example, in most locations a groundwave phase record extending over twenty-four hours is adequate for relative frequency determinations

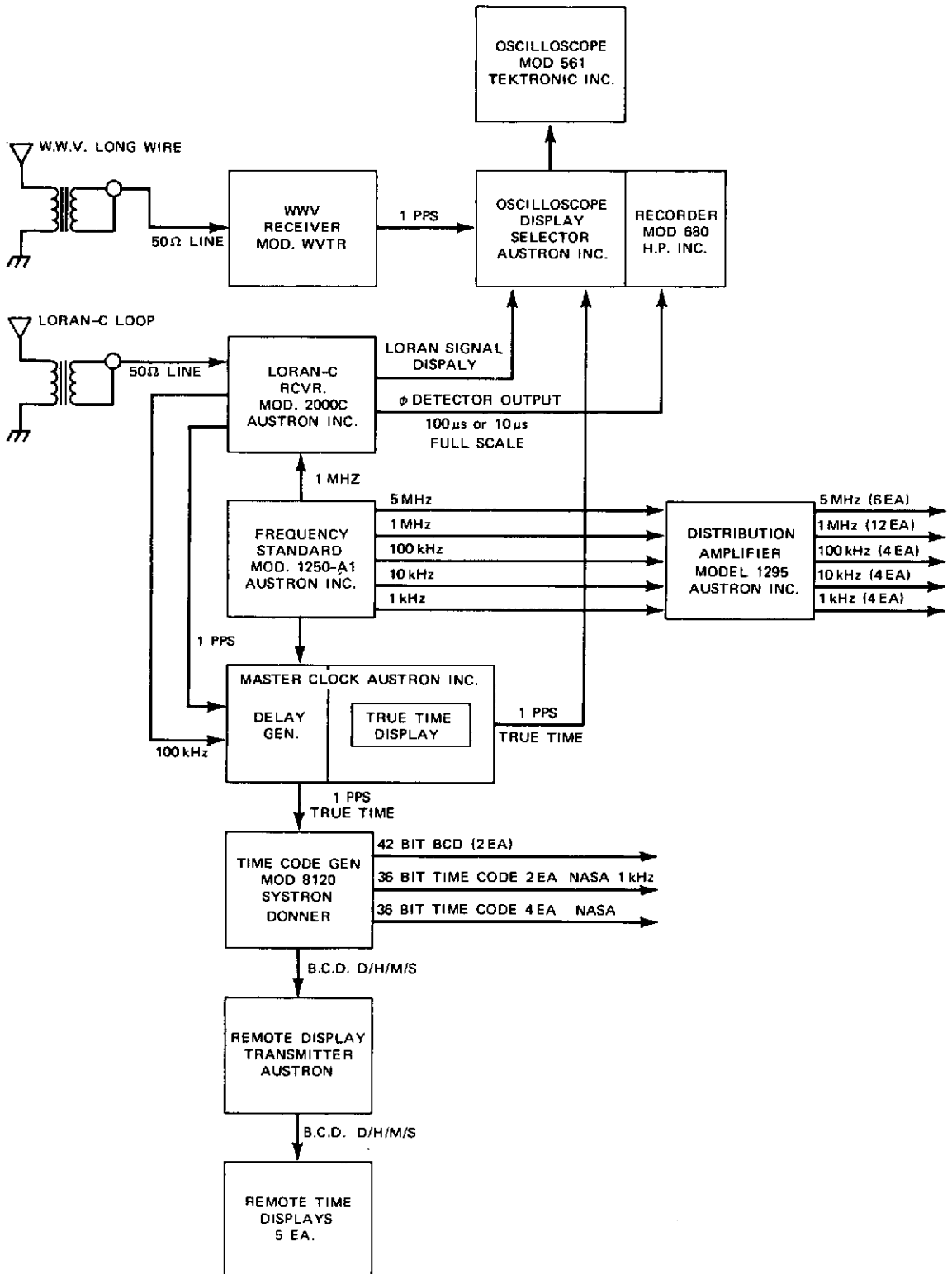

Figure 6-21. Master Timing System

having a probable error of one or two parts in 10^{12} . Similarly, measurements extending over an averaging period of ten days will afford a resolution of parts in 10^{13} . Shorter periods may be tracked, when extreme accuracy is not the immediate objective.

2. Data provided by the record is reduced to yield frequency difference or offset. The basic expression that is used for this purpose is:

$$(a) \quad \frac{\Delta f}{f} = \frac{t_2 - t_1}{\Delta T}, \text{ where } \frac{\Delta f}{f} \text{ is the fractional frequency offset ex-}$$

isting between the local standard and the Loran-C "carrier", as received, and t_1 and t_2 are initial and final phases or time differences, respectively, obtained from the record over the averaging time interval ΔT .

6.9.3.1 Probable Error

Under normal laboratory conditions, cycle phase-tracking stability and resolution of the Loran-C monitor are approximately 50 nanoseconds. Further, the phase stability of the groundwave propagation path is normally a few tens of nanoseconds, even at relatively great ranges. Therefore, at most locations, the limitation on the accuracy of frequency-offset measurements, that are made using the Loran-C monitor, is normally imposed by natural and man-made interference.

6.9.3.2 Traceability

Frequency offset measurements that are made by following the routine that is outlined above are "traceable" to the National Standards of frequency and time, when use is made of signals from synchronized Loran-C transmitters.

6.9.3.3 Substantiation of Data

The Loran-C groundwave, unlike less stable VLF or LF transmissions that are employed for frequency calibration, has no characteristic phase signature such as the diurnal phase shift of the skywave at VLF, or the WWVB type of periodic phase offset and return. If, in the absence of "built-in" phase disturbances of this type, substantiation of the Loran-C phase record is desired, it may easily be accomplished in several ways:

1. A signal envelope record showing the position of tracking point may be made on a second chart channel. Use of a slow-signal strobe scan rate prevents use of an exorbitant amount of chart paper for this purpose.

2. A concurrent record of signal amplitude may be made; however, this is not as definite and clear evidence of tracking as the recycling envelope trace suggested in (1).
3. The tests that are listed for verifying tracking in the operating instructions may be performed; the results may then be entered on the phase difference or amplitude records as annotations in support of the phase record's validity.

Characteristics of the Loran-C receiver are:

Selected features: Model 2000C

RF: Frequency	100 kHz
Sensitivity	Ten nanovolts rms into 50 ohms at tracking point.
Offset voltage	Less than one nanovolt rms, referred to 50-ohm input.
Bandwidth	20 kHz or 50 kHz in tracking channel, switch selected; 5-kHz nominal, acquisition channel.
RF gain controls	0 to 90 db in 10-db steps, and 0 to 9 db in 1-db steps.
Notch filter	One screwdriver adjustment notch filter (3-db bandwidth, 3 kHz or less), tunable from 70 to 130 kHz is provided. Filter controls are accessible from the front panel.
Repetition-rate Synthesizer:	Three-decade control permits selecting any repetition-rate period from 20,000 microseconds to 109,900 microseconds in 100-microsecond increments, including all Loran-C periods from H7 (29,300 microseconds) to SSO (100,000 microseconds).
Phase-code generator:	Phase-code generator synthesizes all code sequences for full-master and full-slave codes.

First-order phase tracking system:	<p>All-electronic phase shifter with better than 50-nanosecond resolution is provided.</p> <p>Time constant is variable in six steps between 10 and 500 seconds.</p> <p>Phase-lock sampling is accomplished by a phase gate one microsecond long.</p> <p>Servo disabling is accomplished by loss of signal. A warning light is furnished.</p> <p>Output timing pulse is synchronized to phase sampling pulse to better than 50 nanoseconds.</p>
Amplitude detector carrier relay:	<p>Amplitude-strobe detector provides indication of carrier level of decoded Loran-C signal. Sampling point 1/4 cycle ahead of or behind phase-tracking point.</p> <p>All-electronic carrier relay circuit stops tracking servo and lights warning lamp when signal disappears.</p>
Frequency Standard input:	1 MHz $\pm 10^{-7}$, to 10 volts peak-to-peak into 600 ohms.
Scan strobe:	Strobe detector scans through zone surrounding tracking point, as an aid to acquisition and cycle identification. Amplifier driven by detector provides output for chart recorder.
Antenna:	RF input compatible with appropriate 5-foot loop whip antenna.

6.10 WEATHER FACSIMILE (WEFAX)

A general requirement of the SMS program is to provide for transmission of WEFAX data obtained from both synchronous and low-orbiting satellites. This presently is being accomplished by use of a VHF downlink carrier frequency, which has a disadvantage of being in a band where RFI poses a severe problem.

A modulation scheme for the WEFAX transmissions utilizes a video signal which occupies a band from about zero to 1.6 kHz. The video signal then amplitude modulates a 2.4-kHz subcarrier, which is then applied as frequency modulation

to the S-band transmitter. An S-band antenna and converter (Figure 6-22) is therefore required by the WEFAX data users in order to receive the WEFAX transmissions.

6.11 DATA COLLECTION SYSTEM (DCS)

The DCS enables environmental data sensed by more than 10,000 data collection platforms (DCP's) to be relayed through SMS to the CDA station.

Examples of possible types of DCP's are:

- Atlantic, Pacific, and Caribbean Ships
- Remote weather stations
- Hydrological sensors
- Buoys
- Agricultural sensors
- Fire weather stations
- Seismic and seismic sea-wave sensors

There are two types of DCP radio sets (DCPRS's); the interrogated (Figure 6-23) and the self-timed (Figure 6-24). Table 6-9 lists the DCPRS modules and their functions. The interrogated DCPRS is equipped with a radio receiver and decoder, so that it can be interrogated through the satellite and commanded to send stored data at any time. The self-timed DCPRS is equipped with an accurate timer that initiates transmission of stored data at a predetermined time.

Both the interrogated and self-timed DCPRS's are equipped to automatically transmit to the satellite in case of emergency. The interrogated DCPRS transmits only its address to the satellite on a frequency assigned for emergency reporting. The CDA station then commands that DCPRS to send its stored data in the normal manner. The self-timed DCPRS transmits its stored data to the satellite on its assigned emergency reporting frequency whenever sensor levels exceed a preset value.

The DCP reports are received by the satellite UHF receiver which is cross-strapped to the S-band transmitter. The CDA station receives the reports on the S-band down-link, and coherently demodulates each frequency channel. The

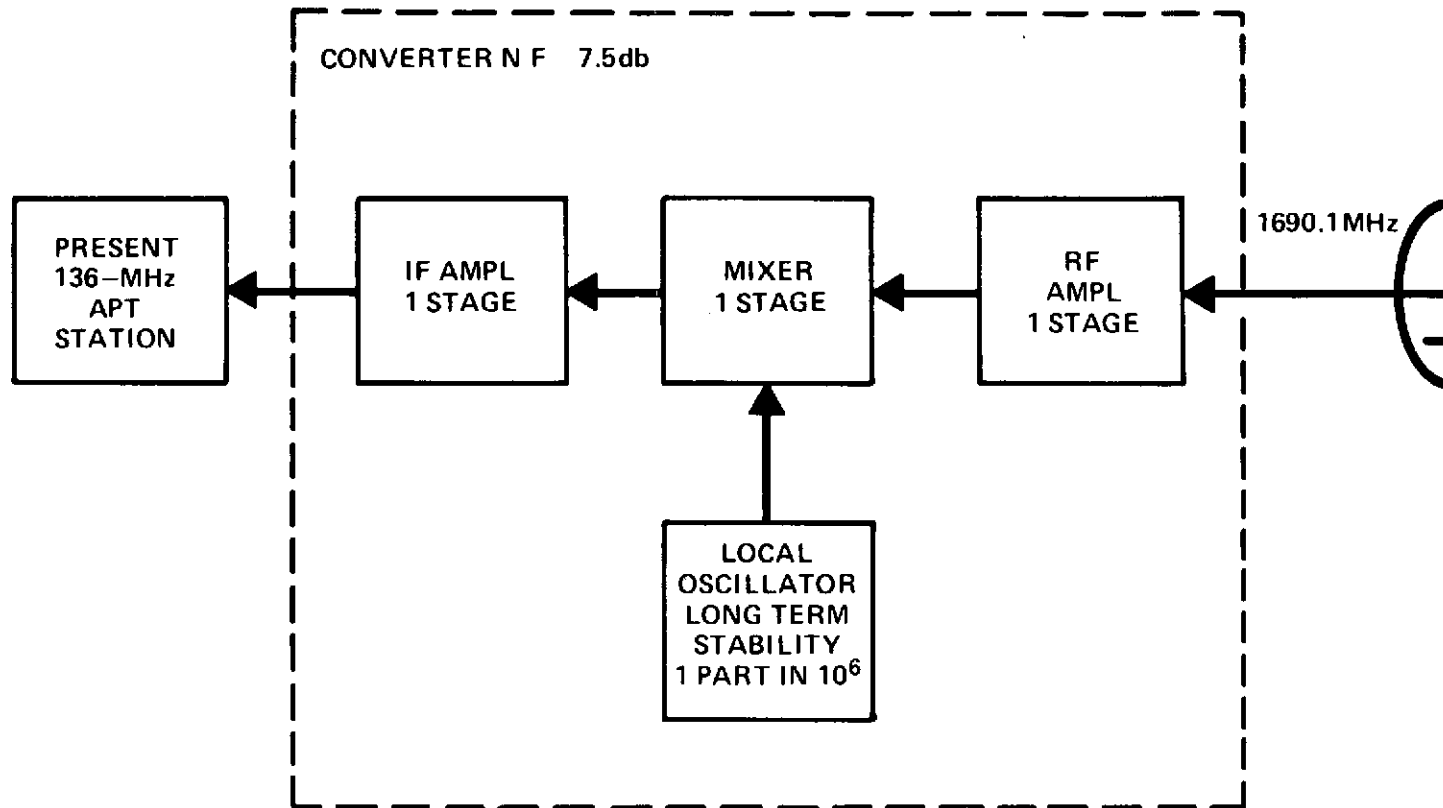

Figure 6-22. S-Band Conversion, Block Diagram

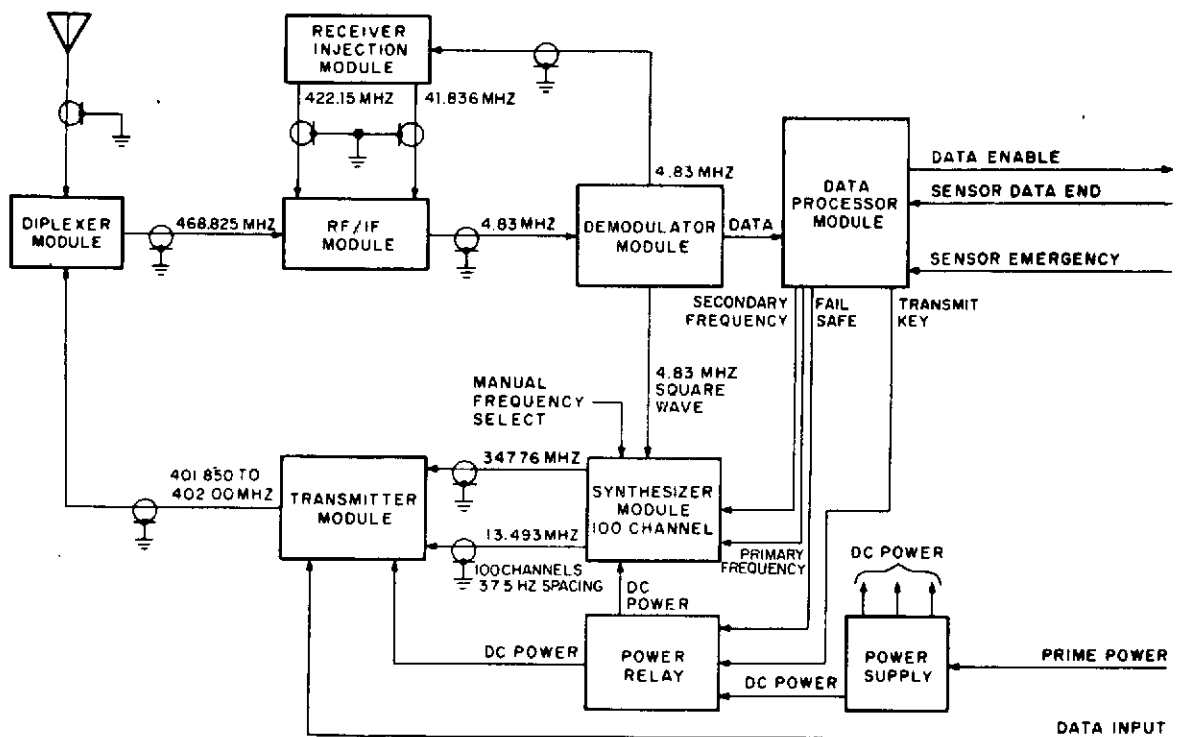

Figure 6-23. Interrogated DCPRS, Simplified Block Diagram

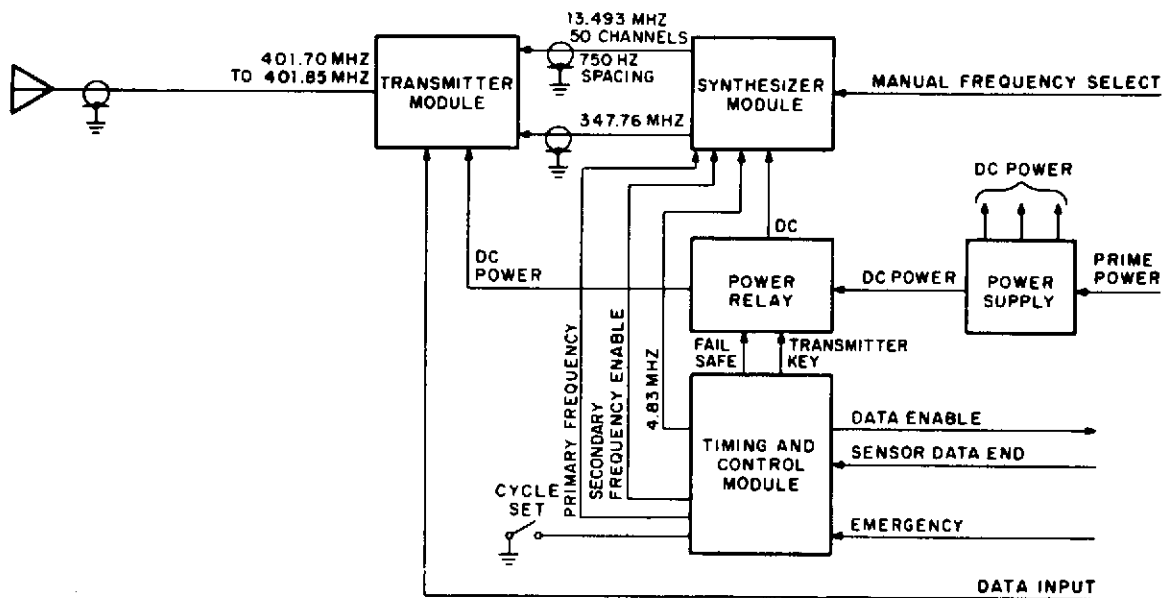

Figure 6-24. Self-Timed DCPRS, Simplified Block Diagram

Table 6-9

DCPRS Modules and Their Functions

Unit	Function
Diplexer module	<p>Couples transmitter and receiver to antenna.</p> <p>Filters transmitter wideband noise.</p> <p>Filters transmitter output from receiver RF stages.</p>
RF/IF module	<p>Provides receiver gain.</p> <p>Provides channel selectivity.</p>
Receiver injection module	<p>Generates injection frequencies for 1st and 2nd receiver mixers.</p> <p>Provides error cancelling oscillator to eliminate self jamming.</p>
Demodulator	<p>Locks receiver to carrier.</p> <p>Provides demodulated data to the data processor module.</p> <p>Provides the 4.833247-MHz reference for the receiver injection module.</p>
Data processor module	<p>Recovers bit rate.</p> <p>Decodes Manchester coded data into "1" and "0".</p> <p>Obtains bit synchronization.</p> <p>Obtains message synchronization.</p> <p>Decodes DCPRS address.</p> <p>Commands transmitter to proper reply in the interrogated mode.</p>
Synthesizer module	<p>Provides 100 channels locked to the received carrier or to the fixed TCXO in the self-timed case.</p>

Table 6-9 (continued)

Unit	Function
Synthesizer module (continued)	Provides for selection of one emergency frequency in either the self-timed or interrogated modes.
Transmitter power amplifier module	Provides RF power for transmission. Manchester-codes digital data. Modulates carrier with serial data bit stream.
Timing and control module	Commands transmitter to proper reply. Provides synthesizer reference for self-timed case. Provides fail-safe function for self-timed case.

data are then sent to the National Environmental Satellite Service (NESS), Suitland, Maryland, by land line for distribution to the user.

6.11.1 INTERROGATED DCPRS

The collection of data from the interrogated DCPRS begins with the preparation of a programmed sequence of interrogation commands which is recorded on magnetic tape. The interrogated DCPRS specification is shown in Table 6-10. The interrogation command consists of a digital word; the first part of which is a preamble common to all DCP's followed by an address unique to each DCP. These digital commands drive a PSK modulator at the CDA station. The interrogation signal transmitted from the CDA station is at an S-band frequency such that it falls within a satellite channel that translates the command to a UHF down-link frequency. At the DCPRS it is received, demodulated, and decoded. If the decoded address agrees with the address stored in the DCPRS, the set is placed into an active mode for transmission of data. Transmissions are spaced 1500 Hz in the band 401.849 588 to 401.998 095 MHz, and the received signals are at the assigned UHF interrogation frequency of 468.825 MHz. The DCPRS-to-spacecraft up-link at UHF is provided by a 5-watt transmitter driving a 10-db gain antenna system. The detailed DCPRS/SC/CDA detailed frequency plan is shown in Figure 6-25.

Table 6-10

Interrogated DCPRS Specification

Operating frequencies	
Receive	468,825,000 Hz
Transmit	401,849,588 to 401,998,095 Hz
Channel spacing	1500.04 Hz
Number of channels	100
Power output	5.0 watts minimum
Spurious response	Non harmonic down 50 db 2nd harmonic -26 db 3rd harmonic -35 db 4th harmonic -50 db
Frequency stability	1×10^{-9} / 0.25 sec short-term; long-term equal to received carrier (coherent system)
Modulation	
Receive	± 70 -degrees PSK Manchester coded data
Transmit	± 70 -degrees PSK Manchester coded data
Code format for transmission	ANSII format at 110 band
Sensitivity	-130 dbm
Bit error probability	1×10^{-6}
Bit rate (receive)	100 bit/sec
Code address	15 bit MLS message sync 31 bit command
Standby power dissipation	Less than 200 mw
Supply voltages	+5 and +12.5v
Antenna	60-degree beam width (maximum) at -3 db points, 10-db gain, right-hand circular polarization, 50-watt rating, and 50-ohm nominal impedance
Temperature range	-20 to +50°C
Size and weight	15.63 by 21.63 by 12.88 in. -17.07 lb

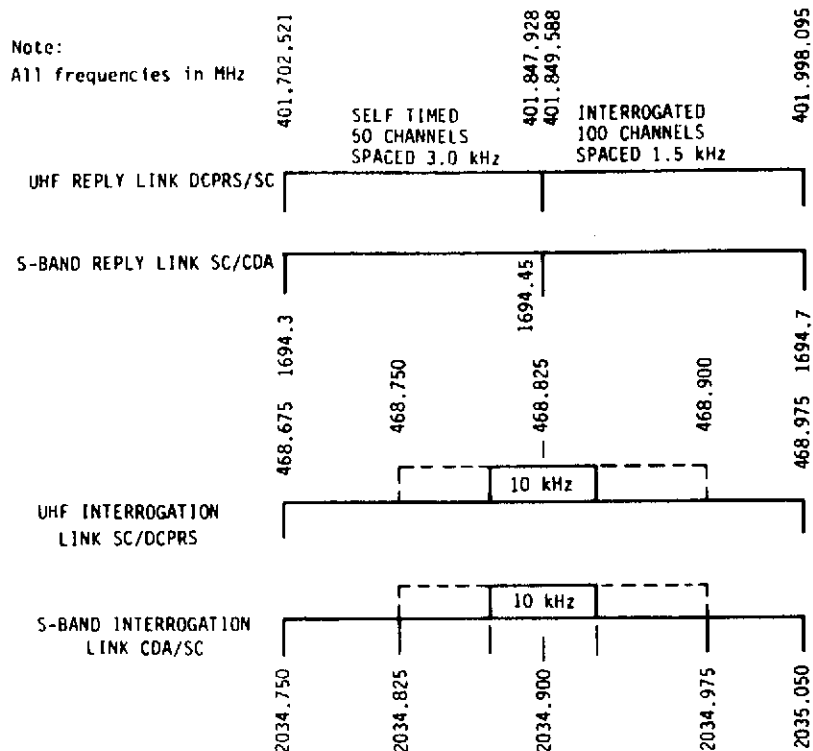

Figure 6-25. DCPRS/SC/CDA Detailed Frequency Plan

6.11.2 SELF-TIMED DCPRS

The self-timed DCPRS has a clock that synoptically turns on the transmitter in 1-to-12-hour intervals in 1-hour increments and settable to any period in the 1-to-12-hour interval. The self-timed DCPRS specification is shown in Table 6-11.

When not transmitting, the DCPRS is in a "power-down" mode in which only the synoptic clock is operating. When the synoptic time period is reached, sensor data enters the DCPRS and the transmitter carrier is phase-shift keyed by the data. The operating frequency is selectable at the DCPRS for any one of 50 channels spaced 3000 Hz apart in the band from 401.702 521 to 401.847 928 MHz (Table 6-11). At the end of data transmission, the set is "powered-down" to its clocking mode. Transmission times, dependent upon the type of DCP sensors, should average approximately 30 seconds. The DCPRS-to-spacecraft up-link at UHF is provided by a 5-watt transmitter driving a 10-db gain antenna system.

6.11.3 INTERROGATION FORMAT

The interrogation format is required to have sufficient length to address at least 100,000 DCP's. This can be done with 17 bits in the absence of any errors. A

Table 6-11

Self-Timed DCPRS Specification

Operating Frequencies	401,702,521 to 401,847,928 Hz
Channel spacing	3.0 kHz
Number of channels	50
Power output	5 watts minimum
Spurious response	Non-harmonic down 50 db 2nd harmonic -26 db 3rd harmonic -35 db 4th harmonic -50 db
Frequency stability	5×10^{-7} over temperature 1×10^{-6} aging per year 1×10^{-9} / 0.25 sec short term
Timing	1-to-12-hour reporting intervals in 1-hour increments; may be set to any 30-second period in the 1-to-12-hour interval.
Modulation	± 70 -degree PSK Manchester coded data
Code format	ANSII format at 110 baud
Antenna	60-degree beam width (maximum) at -3-db points, 10-db gain, righthand circular polarization 50-watt rating, 50-ohm nominal impedance
Standby power dissipation	Less than 100 mw
Supply voltages	+5 and +12.5 v
Temperature	-20 to +50°C
Size and weight	15.63 by 21.63 by 12.88 in. -12.07 lb

31, 21-Bose-Chaudhuri-Hocquenghem (BCH) code is used to provide 2^{21} separate address commands allowing a maximum of two errors in each command. This coding sequence provides over two million separate usable commands. A typical interrogation message is shown in Figure 6-26. A 15-bit maximum linear sequence (MLS) precedes the 31, 21-BCH code to provide synchronization.

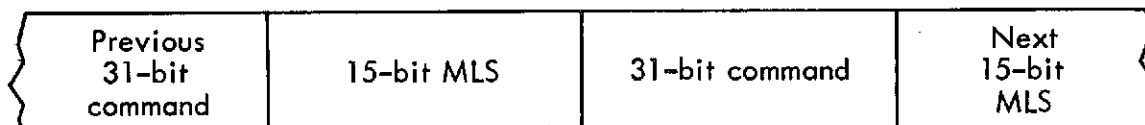

Figure 6-26. Typical Interrogation Message

6.12 TRILATERATION RANGING SYSTEM

The trilateration ranging system provides data which are used in determining the latitude and longitude grids for the stretched VISSR pictures. This is accomplished by employing a trilateration technique wherein a near simultaneous measurement of three range vectors are obtained from the CDA station and two turn-about-ranging stations (TARS) as shown in Figure 6-27. The three range vector measurements are as follows:

- CDA to SMS and back
- CDA to SMS to TARS-1 to SMS and back to CDA
- CDA to SMS to TARS-2 to SMS and back to CDA

Although range is a distance, it is usually referred to as a time delay, which is the quantity actually measured. Usually, zero range is defined as a point on the station antenna, such as the crossing of two axes.

The ranging system uses a five-sidetone PM modulation structure from the CDA station and a three-channel frequency division multiple access technique for simultaneous reception of the signals at the CDA station. The ranging tone frequencies are 200 kHz, 27.77 kHz, 3.968 kHz, 283.4 Hz, and 35.46 Hz. The total allocated system bandwidth is 8.2 MHz centered at 2029.1 MHz and 1687.1 MHz, which are the SMS receive and transmit frequencies, respectively.

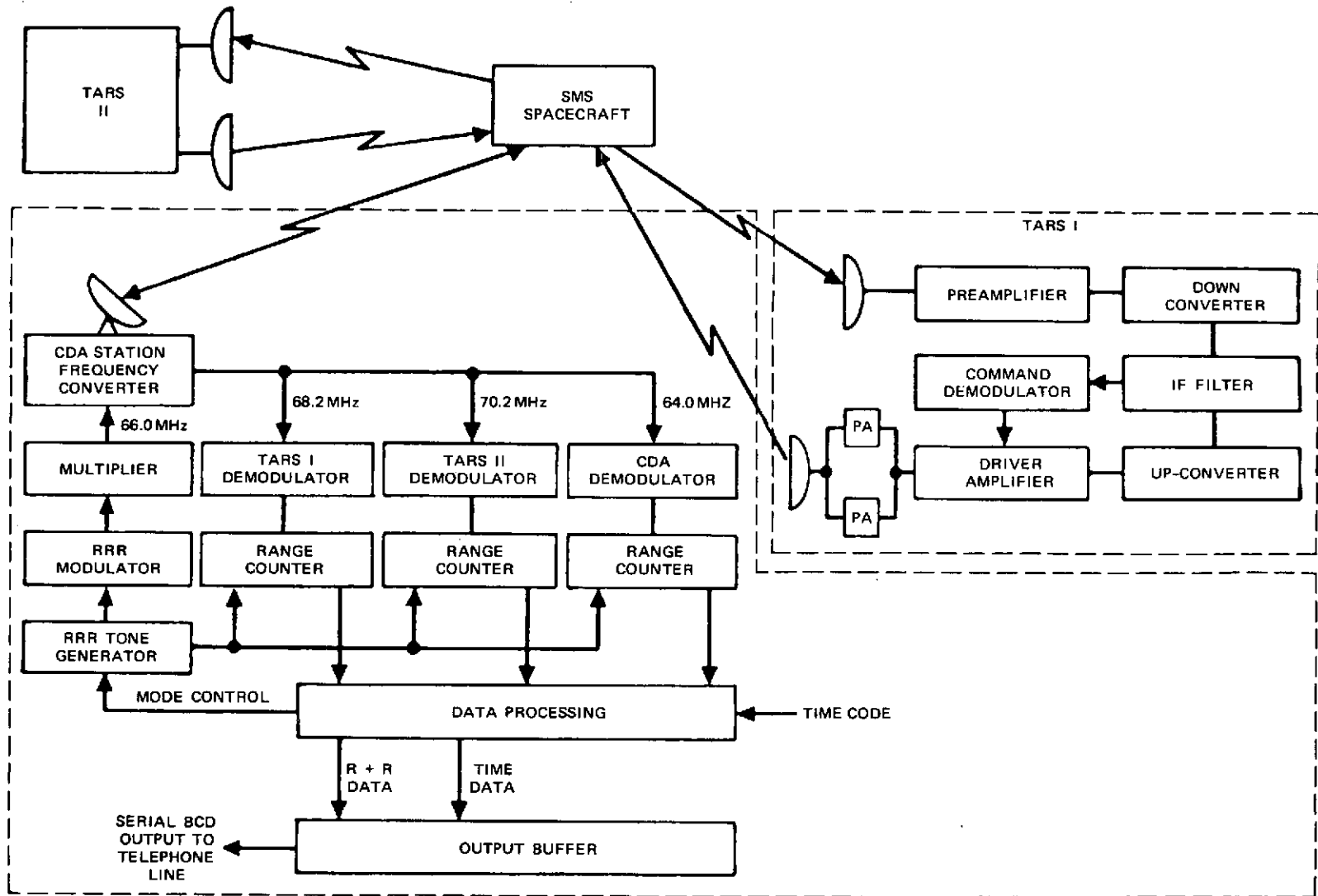

Figure 6-27. Trilateration Range and Range Rate System, Block Diagram

6.13 SYNCHRONIZER/DATA BUFFER (S/DB)

The SMS is placed in orbit at a synchronous altitude (approximately 22,300 nmi above the earth's surface) in a plane nearly orthogonal to the earth's spin axis. SMS carries a radiometer with both visible and infrared (IR) sensors. This visible infrared spin-scan radiometer (VISSR) depends upon the spacecraft spinning for line scanning. A stepped mirror provides scan-to-scan spacing (see Figure 6-28). The satellite rotates at a spin rate between 50 and 110 rpm with the spin axis nearly orthogonal to the orbit plane and oriented to normally scan from west to east. Successive scan lines of a frame normally progress from north to south.

There are ten sensors (eight visible and two IR). The instantaneous geometric field-of-view (IGFOV) of the two IR sensors is each nominally 200 by 200 micro-radians (μr); each of the visible sensors has a nominal IGFOV of 25 by 25 μr . The eight visible sensors are grouped so that the total north-south FOV is nominally 200 μr . The eight visible sensors and the two IR sensors cover the same swath on the earth during each scan; these sensors are displaced along the scan direction. The visible channel scans the earth first, as shown in Figure 6-29, followed, with a delay of 945 μr , by the primary IR channel (IR1). After an additional delay of 419 μr the redundant thermal sensor (IR2) scans the same earth point.

6.13.1 SPACECRAFT DATA INTERFACES

The VISSR video and scanner line number data are transmitted to the CDA station in real time using a wideband digital link employing quadrature modulation. A timing signal, to permit scan-to-scan alignment, is derived from the output of a sun-sensor signal and is transmitted both directly using an analog channel and indirectly as part of the quadrature channel.

6.13.1.1 Quadrature Data Format

The VISSR data are placed in digital form in the satellite by sampling and A/D conversion. The visible data are sampled and, by a non-linear process which approximates the square root function, are converted to a 6-bit number. The VISSR output is then placed in multiplexed digital form and transmitted using quadrature modulation once-per-satellite rotation. This transmission starts while the radiometer azimuth angle (measured in the spin plane with respect to the earth's polar axis) is at -11.1 ± 0.5 degrees and ends at $+9.7 \pm 0.5$ degrees. The period from the start to -9.7 ± 0.5 degrees is used for synchronization preamble data. With 0.2 degrees allowed for power on and off transients, the total

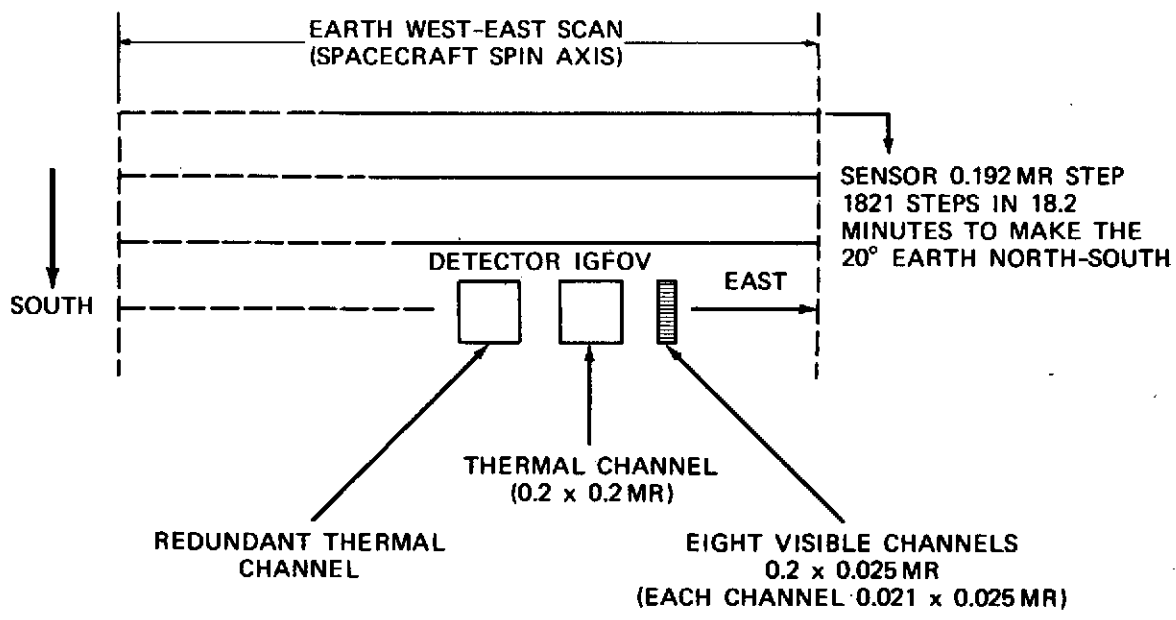
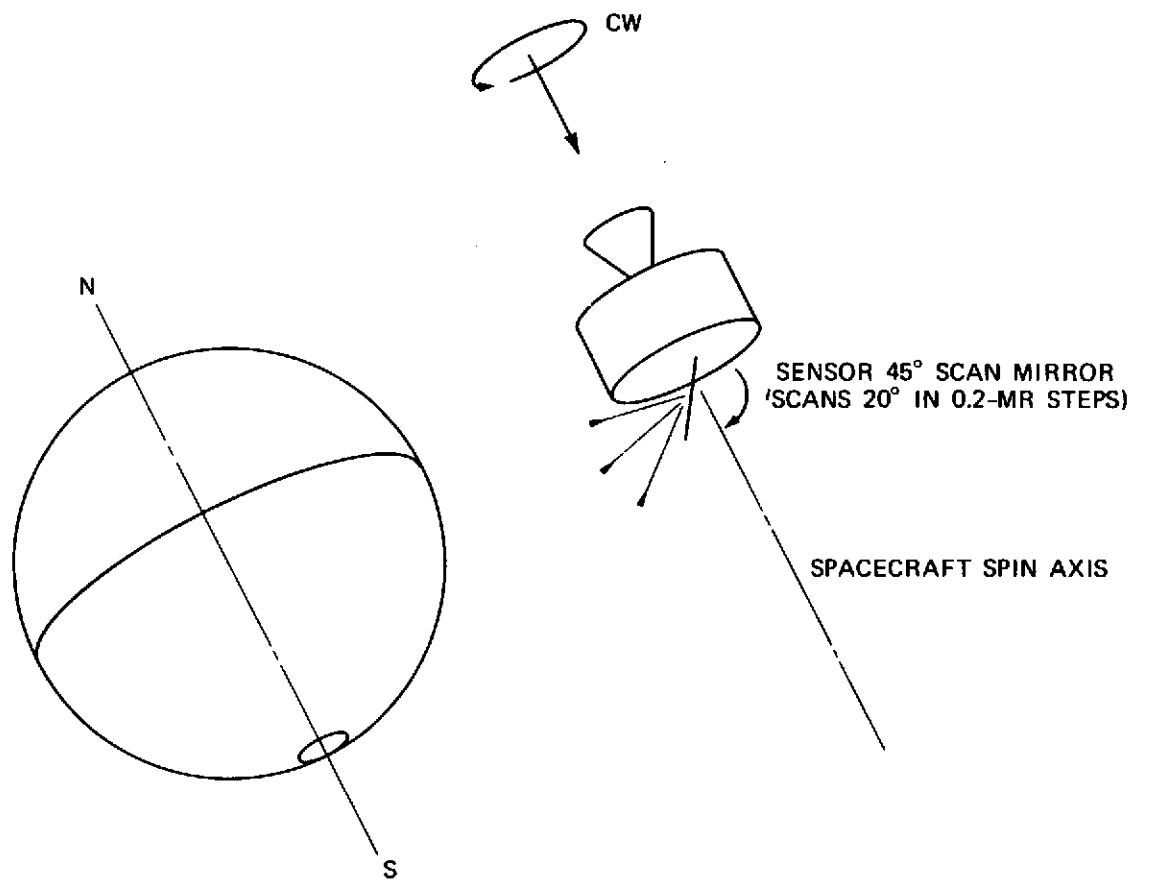

Figure 6-28. Synchronizer/Data Buffer System Configuration

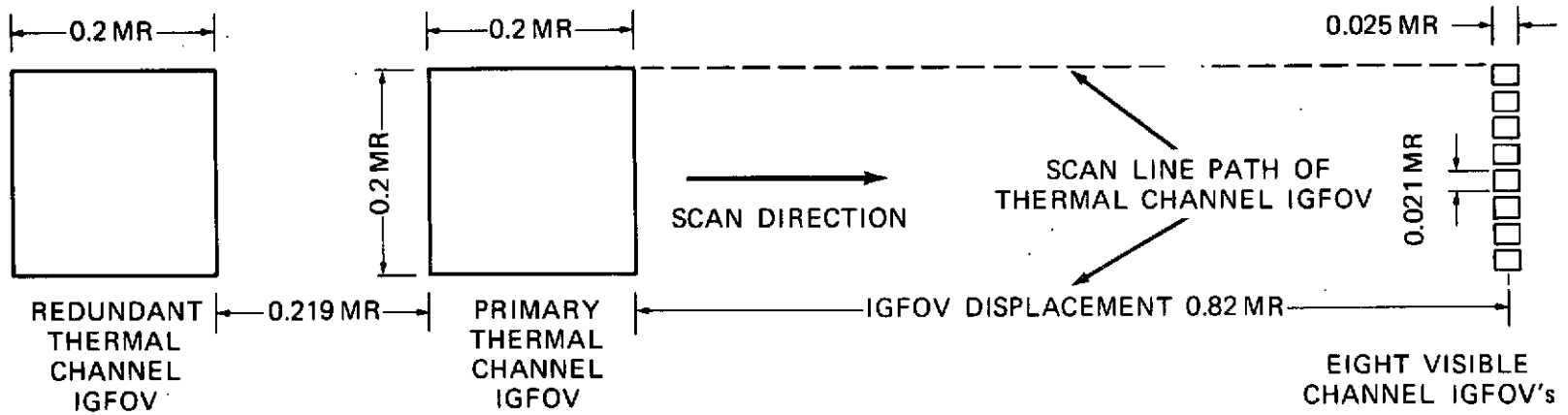

Figure 6-29. VISSR Thermal Channel and Visible Channels IGFOV Arrangement

transmission employs at most 22 degrees of satellite rotation and includes, at least, 18.4 degrees of properly centered earth data.

6.13.1.2 VISSR Scan Control

The satellite normally produces the first line of a picture by scanning from west to east with the VISSR near its north limit. By inverting the satellite orientation, these directions are all reversed. In the following discussion the inverted orientation of the satellite is not explicitly mentioned. However, interchange of the words north and south and also east and west provide a correct description in the inverted mode.

The resting position of the scanner is the north limit; when this is reached, scanning ceases unless commanded.

There are five major commands which are used to control scanning:

- Scanner stepping on: Scanner stepping commences in a direction and at a rate determined by the state of the scanner when scanning ceases.
- Scanner stepping off: This commands the cessation of scanner stepping. This command is not normally employed since scanner stepping stops automatically when the north limit is reached.
- Scanner stepping direction reverse: This command causes the stepping to change from its present direction (southward or northward) to the reverse direction. The stepping rate in retrace (northward) is $10 \frac{2}{3}$ times normal while the southward rate is determined by the step-rate state as controlled by the following two commands.
 - Normal step rate: This command causes the scanner, when stepping southward, to step at the rate of one step per satellite rotation.
 - Rapid step rate: This command causes the scanner to step at the rate of $10 \frac{2}{3}$ steps per satellite rotation.

The S/DB automatically executes the reverse command using an interface with the command encoder. The command encoder sends the S/DB an execute enable signal (logic ONE) indicating that the reverse command has been loaded and verified and that the command encoder can accept the execute pulse. Otherwise, this enable signal is at logic ZERO.

Normally, the picture starts just below the north limit after the scanner stepping is commanded on. There are two types of radiometer calibration which may occur near the start of such a normal frame of data. Designating the scan count at the north limit as N and successive scan counts (representing steps towards the south) as N+1, N+2, etc., the first scan which contains calibration data has scan number N+3. This calibration occurs only each time it is commanded using the "internal calibrate, on" command. It produces a thermal calibrate using a shutter. The following scan, N+4, always contains calibration data involving an electronic staircase waveform.

The first calibration method of the thermal channel is provided using an ambient blackbody shutter arrangement actuated by command. The shutter, with temperature monitored, is placed in the FOV near the filter-detector assembly; therefore, it does not detect possible gain changes caused by the primary optical system.

6.13.2 MECHANICAL DESCRIPTION

The S/DB equipment consists of four single cabinets containing electronic subsystems, an ASR Model-35 teletype with paper tape punch and reader, and an Electronic Image System Corp. (EISC) photorecorder.

All units in the cabinets, except breaker panels, control panels, power supplies, and the magnetic tape unit, are installed on chassis slides to facilitate removal and provide access for maintenance. The slides are equipped with safety catches to hold the unit in the extended position; when the catch is released, the unit may be returned to the cabinet. Each cabinet has its own power supply, and an individual power breaker and elapsed time meter located at the top of the cabinet. AC power is routed to individual units within each cabinet by molded power distribution busses mounted vertically on inside rails.

Figures 6-30 and 6-31 indicate the front panel assignments of the individual cabinet assignments. The computer and peripherals cabinet contains the time display, the magnetic tape deck, the TEMPO computer and core extension module, the computer control panel, and a pull-out writing surface.

The central timing unit contains a frequency counter, the data source selector, an oscilloscope, a planar array bucket, a frequency synthesizer, and a power supply assembly.

The data handling unit cabinet contains three core memories including integral power supplies, the rear mounted gray scale program board, two planar array buckets, and a power supply assembly.

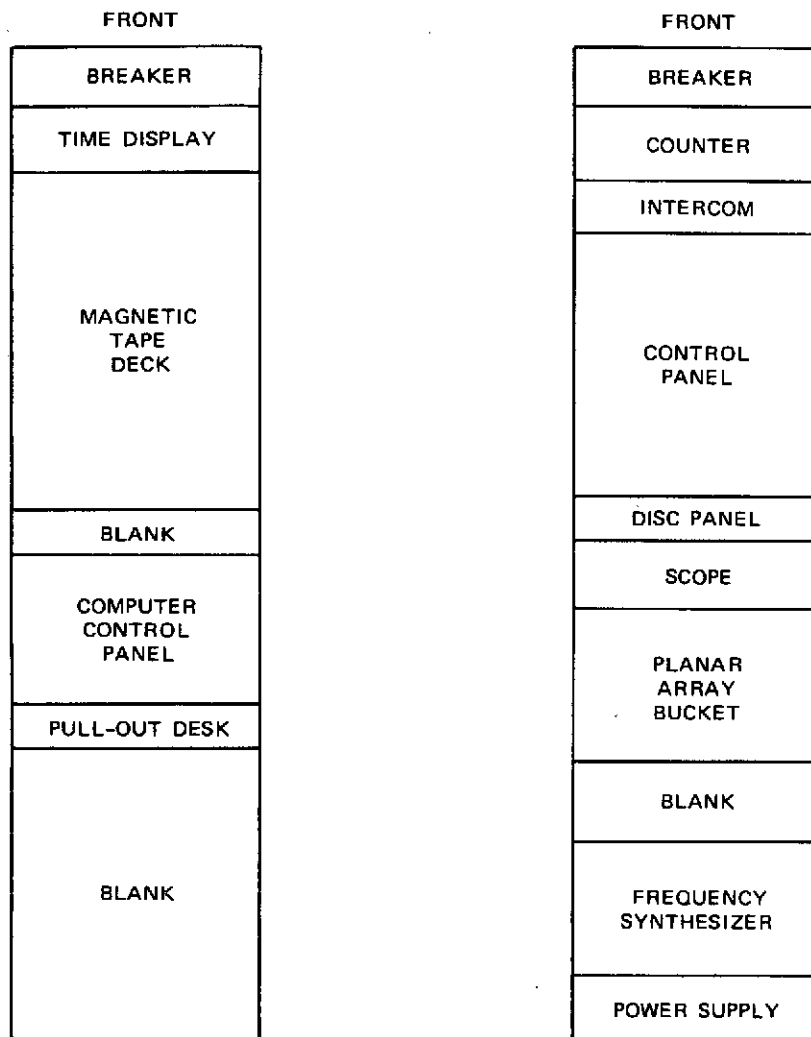

Figure 6-30. Computer & Peripherals and Central Timing Unit Equipment Layout

The analog processing unit contains the quadriphase test modulator, demodulator, demultiplexer, a power supply assembly, the bi-phase modulator, and the bit-rate frequency lock loop.

All electronic subsystem logic is placed on planar array boards. The planar array is a G-10 glass epoxy board 11.3 by 7.3 inches including the two 60-pin card edge connectors. The front side of the board contains spring contact sockets for mounting up to 100 sixteen-pin dual-in-line integrated circuit packages. The rear side of the board contains wiring posts for use with a tape controlled automatic wiring machine.

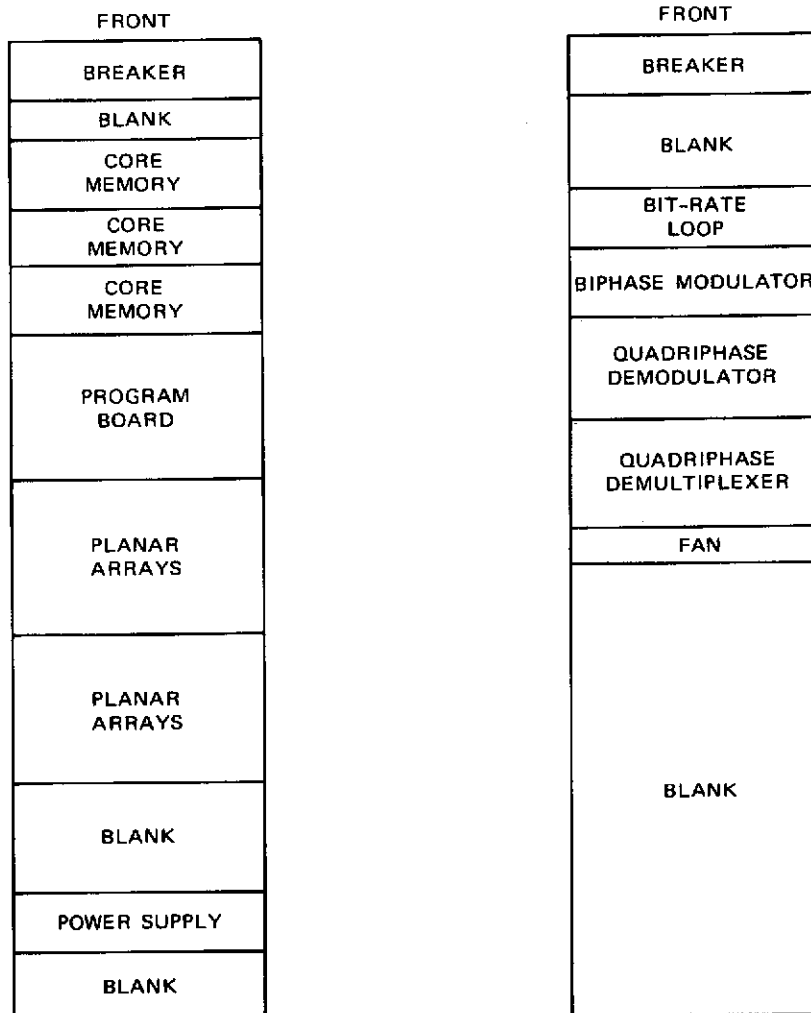

Figure 6-31. Data Handling Unit and Analog Processing Unit Equipment Layout

The planar array boards are mounted in a multi-card rack (bucket) assembly which may contain up to 10 boards per bucket. The bucket has card edge connectors which mate with the planar array boards. The bucket has machined card slots and phosphor bronze card guide spring fingers for each board. Access to the individual IC's on the board can be gained by using an extender board.

Cabinet cooling is accomplished by forced air flow from the false floor. In addition, units such as the computer, core memories, and oscilloscope have their own individual fans.

6.13.2.1 External Interfaces

All input/output (I/O) connections are made by the false floor through the bottom of each cabinet. All wires and cables are brought immediately to an I/O connector panel. Each connector panel is aluminum with female TNC connectors attached to a micarta insert to permit isolating the coaxial cable shields from cabinet ground. Each panel also includes multipin connectors for accepting digital multiconductor cable.

6.13.3 SYSTEM DESCRIPTION

The data flow through the S/DB is discussed with reference to Figure 6-32. The 4 ϕ DEMOD/DEMUX accepts the 70-MHz signal derived from the satellite's wide-band transmission. This unit demodulates the input to form a baseband digital signal which is then bit synchronized. After bit synchronization, word synchronization is achieved; during this process the data are grouped in eight or six-bit groups and sent to the input processor on eight data lines. In addition to these data lines, which are provided by the DEMUX, there are data strobes and control signals.

The central timing unit controls the operations of most of the other units in the S/DB; however, these control lines are not shown in the block diagram. The most critical function of this control is performed by the phase locked loop (PLL) subunit. The PLL divides the satellite rotation into 6289920 equal parts, regardless of spin period, and referenced to the sun. The time at which the satellite's sensor sweeps past the sun is sent to the CDA station as a real-time analog sun pulse and as a digital sun count. The analog sun pulse is supplied to the S/DB from the telemetry receiver after being thresholded there. The sun pulsewidth is $90 \pm 25 \mu\text{sec}$; the leading edge contains the timing information. The digital sun count is provided by the 4 ϕ DEMOD/DEMUX as a number representing the eight least significant bits of a counter in the spacecraft operating at a 3.5-MHz rate. This count is used to infer precisely the location of the analog sun pulse.

In operation, the PLL predicts the time at which each sun pulse arrives. The difference in time between the arrival of the actual and the predicted sun pulses is termed the PLL error, and is subsequently used to control the phase and frequency of the PLL.

The frequency is produced by a digitally-controlled synthesizer having a stable 1-MHz input. The synthesizer frequency is precisely equal to $\frac{6289920}{2P}$ for a spin period P. The maximum frequency, achieved at 110 rpm, is 5765670 Hz.

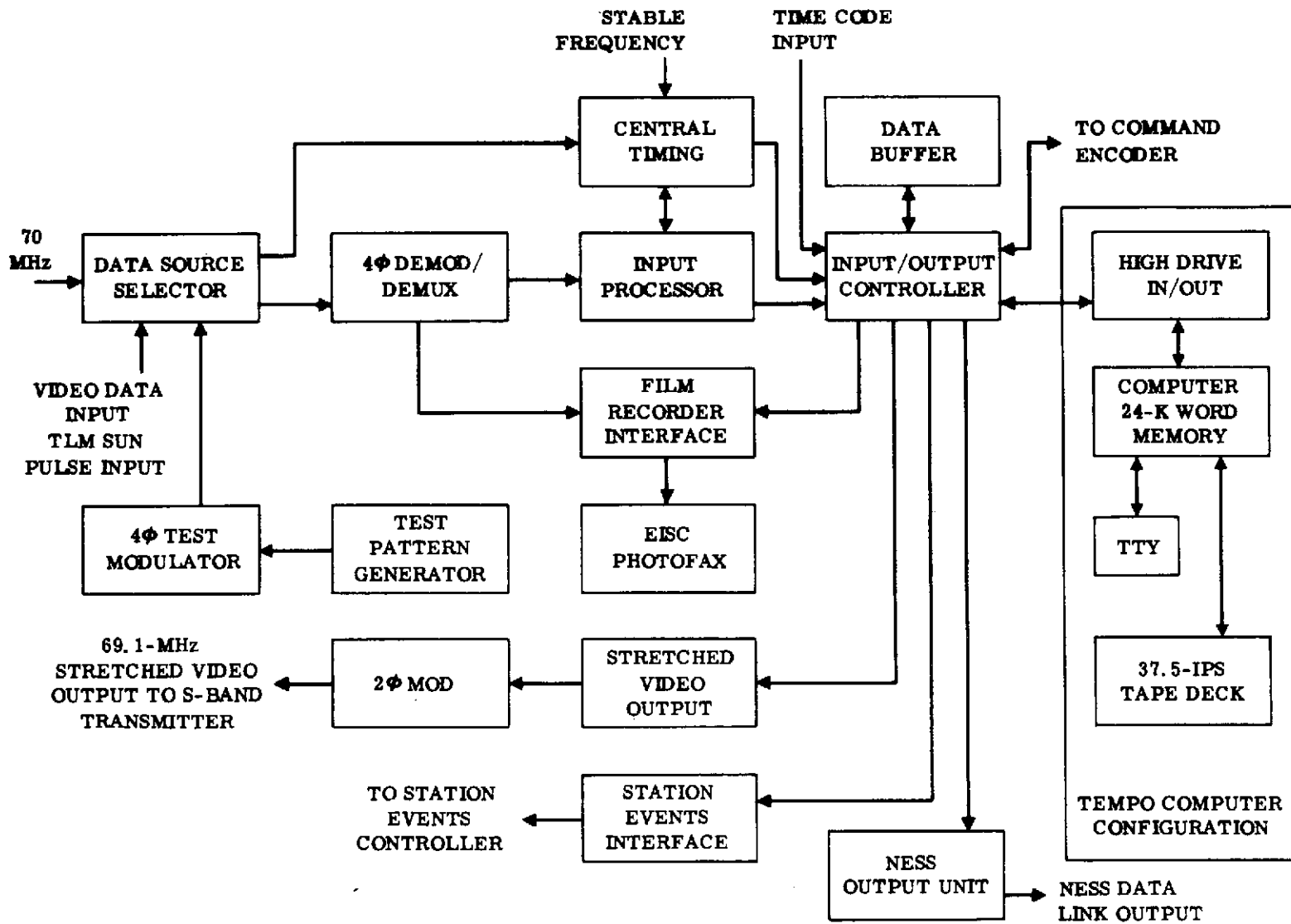

Figure 6-32. Synchronizer/Data Buffer System, Block Diagram

The basic S/DB clock frequency, termed the VCO frequency, is double the synthesizer frequency.

Among the major timing signals output by central timing is the equal angle clock formed by dividing the VCO frequency by 21. The second set of major outputs relate to the stretched video (SV) retransmission. This includes dividing the satellite's rotation into 10 sectors; the phasing of these sectors is controlled by an offset related to the satellite's rotation angle during propagation of the satellite's signal to the CDA station. The SV bit clock is derived by dividing the VCO frequency by six in the highest resolution SV mode.

The steady state bandwidth of the PLL is adjustable in two steps to minimize the tracking error as a function of the sun pulse noise and satellite spin acceleration. In addition, at narrow bandwidth settings, the bandwidth during mirror retrace is increased to reduce the tracking error. This bandwidth is then returned to its normal value at the beginning of each frame to minimize the effects of the step-in-mirror acceleration.

To acquire data from the earth, the sun-referenced PLL output must be offset by an angle equal to the sun-earth separation as viewed from the satellite. This offset angle, β , changes with time due mainly to the earth's spin; to a satisfactory approximation expressed as follows:

$$\beta = \beta_0 + \beta_0(t-t_0)$$

where β_0 is β at time t_0 .

The angle β need be computed only once per satellite rotation and is implemented by software in the computer.

The input processor receives the parallel digital data from the 4 ϕ DEMOD/DEMUX as indicated in Figures 6-33 and 6-34. The first 56 bits received are treated specially; the scan number and scan direction bits are stored for later transmission to the computer and the digital sun count is sent to the PLL. No check of the sync word is made as it is assumed that this function has already been adequately performed. During the remainder of the transmission the sync-1 and sync-2 words are checked; a count is kept of the number of times these sync words are in error. This error count is used as a measure of the bit error rate.

The visible and IR data, as well as some documentation words, are transferred to the I/O controller. In mode C (maximum stretched visible data) the visible data are averaged to reduce their resolution to that of the IR data. These visible

WORD ZERO FORMAT

- A. SCAN SYNC - 16 BITS
- B. SCAN COUNT - 12 BITS
- C. SUN PULSE - 8 BITS
- D. FILLER BITS - 20 BITS

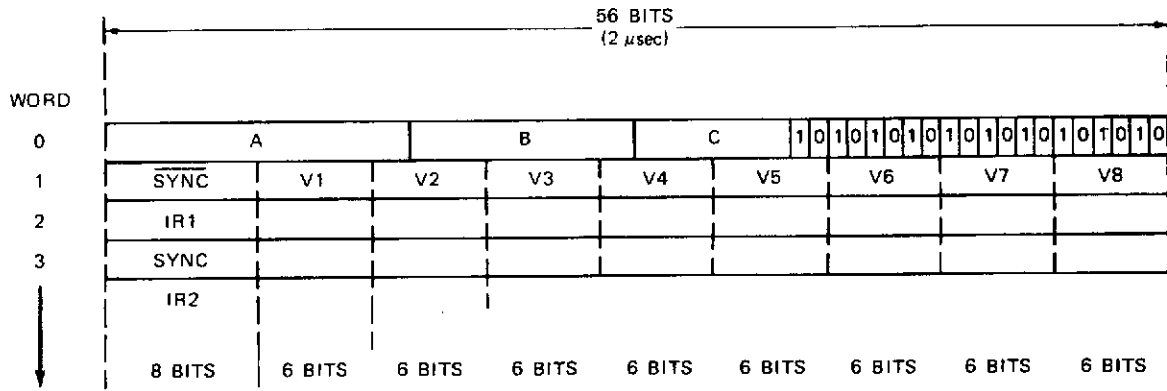

28 MBS MODE

Figure 6-33. VISSR PCM Data Format, Mode 1

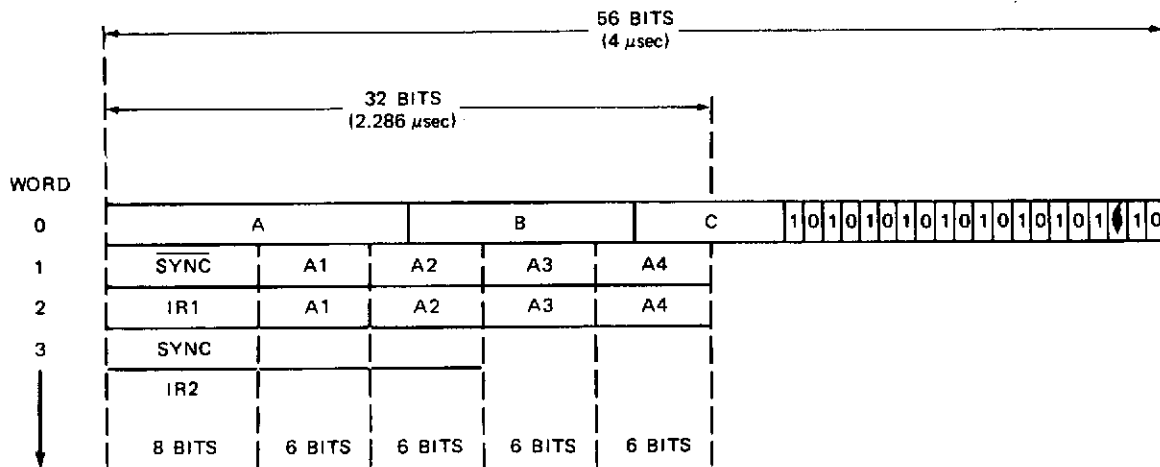

14 MBS MODE

Figure 6-34. VISSR PCM Data Format, Mode 2

data then replace IR1 or IR2 during output of the I/O controller. Virtually all data pass through the I/O controller. During data acquisition the visible data are passed to the buffer while the IR data (and in mode C, the average visible data) are passed to the computer. Other data required by the computer, such as time from the time code translator and the PLL error from central timing, are also passed to the computer.

While this data acquisition is taking place the I/O controller is outputting visible data from the buffer. In mode B the visible data are also averaged during output to reduce its resolution. During the pre-IR period, while a random pattern

is transmitted to the satellite, the PLL tracking correction is made, the sun-earth (β) angle is incremented, and time is provided to the computer. During the following sector the IR data from the computer are transmitted.

The buffer stores all the visible data in three sections of memory. Two sections are used to record the satellite data while the third is outputting stretched video. The buffer accepts data samples for all eight sensors in parallel and provides the output of one sensor at a time in sequence.

A major function of the computer is the processing of IR data. This includes table look-up, buffering, spatial alignment of IR1 and IR2 with respect to the visible data, selection or combination of the IR for retransmission, and performing diagnostics on the data. In addition, the computer reads the grid tape and merges the proper grid with the IR data by inserting a bit in the most significant location of the nine-bit group transmitted to the satellite. This same bit is also used to insert fiducial marks and annotation on the picture. A 32-step gray scale is introduced by replacing VISSR data with the desired fixed intensity values.

In the maximum stretch modes (C and D) the grid and other annotation are inserted in these data by replacing the normal video and selected black or white points. This approach minimizes the required data bit rate and also simplifies the facsimile equipment.

The SV output unit converts the parallel inputs from the buffer and computer to a serial bit stream. For the visible data in modes A and B, the bit and word synchronizing pattern is inserted as well as a number to identify the sector (or group of sectors). The visible data gray scale, selected by a patch board, is also introduced here. Finally, alternate bytes (after the word sync pattern) are complemented to permit bit sync to be maintained at the DUS. The data stream is coded using a pseudo-noise sequence generator which also provides the word sync pattern. Subsequently, the data are converted to NRZ-S (each bit transition implies a ZERO bit state) and supplied to the 2 θ modulator which generates a biphase modulated 69.1-MHz IF signal.

In addition to the stretched video to the spacecraft there is a stretched video land-line link to NESS at Suitland, Maryland. This link is fed from the computer.

A station events controller (SEC) interface is also included to route up to 64 bits of status and error indicators to the SEC for subsequent transmission to NESS.

6.13.3.1 Monitor

The video baseband data stream can be monitored using the analog outputs from the 4Ø DEMUX/DEMODO or the stretched digital data prior to the SV output unit, using a film recorder. The film recorder was used for ATS-1 and ATS-3 image recording in black and white. This unit was modified to accept up to 1821 lines each having 3822 samples of analog or digital data.

Input to this film recorder is provided by the film recorder interface unit. This unit selects the proper data for display and supplies these data on one analog and eight digital lines together with strobes and line and frame reset signals all in the proper form. Normally, in mode A every fourth sample of every eighth line is used. There is a line selection switch to permit the choice of any one line of the group of eight formed during each satellite scan. This approach is also extended to the other modes to always form the same number of samples and lines; where appropriate, a line select choice is made available.

The final function of the S/DB is that of testing. With a built-in test capability, the entire system is checked out under controlled conditions without the need for satellite data. The test pattern generator provides several high resolution patterns in the form of a digital bit stream at 28 or 14 Mb/sec. These data are outputted as a sequence of 2-bit words at a word transfer rate equal to half the bit rate. Following this is the test 4Ø modulator which generates a 70-MHz modulated signal. This signal can then be introduced to the 4Ø demodulator instead of the normal 70-MHz signal received from the satellite. Switching of such normal and test signals is accomplished by the data source selector.

The remainder of the units operate normally to produce the stretched video. In fact, if desired, this test stretched signal can be relayed through the satellite for checkout of the data utilization stations (DUS's).

6.13.3.2 Retransmission Modes

The satellite is capable of transmitting digital video data for the complete 360 degrees of each rotation. However, the digital wideband data from the VISSR at 28 or 14 Mbps is transmitted for, at most, 22 degrees of satellite rotation. During the remaining 338 degrees of rotation the satellite acts as a repeater and retransmits the uplink digital video from the CDA station. The major function of the S/DB is to acquire the wideband data and process it for this uplink transmission. This retransmission period is divided into nine parts to permit the data from the IR and eight visible sensors to be outputted. This 338-degree period, if divided equally, requires at most 37.5 degrees for each line of video. This is achieved by assigning one-tenth of each rotation (36 degrees) to each visible sensor, V1-V8. This left, at most, $360 - 8 \times 36 - 22 = 50$ degrees for

the IR retransmission. By providing 45 degrees (one-eighth of a rotation) for this output, 5 degrees spare was achieved. This remaining 5.0 degrees is used (a) to provide a 2.0-degree signal for carrier recovery at the data utilization station, (b) to provide a 0.2-degree tolerance in S/DB timing, (c) to provide a 0.9-degree tolerance for variation in spacecraft to CDA station range, and (d) to provide a 1.9-degree margin. The 27 degrees total of this 5-degree interval and the 22 degrees wideband transmission are termed the pre-IR period since it immediately precedes the 45-degree IF period of retransmission.

Each IR or visible data line divides the satellite rotation into (8 or 10) equal parts so that the retransmitted video can directly be formed into an image using a drum recorder.

The resolution of the image data is expressed in terms of the nominal spacing, at the subsatellite point, of the video samples. For example, at 100 rpm, in the highest resolution mode, the spacing of visible samples along a line is $21\mu r$ and between lines is $24\mu r$. At a satellite range of 22,300 nmi, the line spacing corresponds to 0.54 nmi and the spacing in the scan direction corresponds to 0.47 nmi. This 0.54 by 0.47-nmi spacing is nominally expressed as 1/2 by 1/2-nmi spacing. Similarly, the IR resolution is nominally expressed as 4 by 2-nmi spacing.

By averaging video samples, the resolution is reduced to 1 by 1 nmi, and the number of visible lines per scan is reduced from 8 to 4. Each of these lines is retransmitted using 72 degrees per line, thus dividing the spacecraft rotation into five equal parts.

In the 1/2 by 1/2-nmi mode the photorecorder drum rotates at 10 times the satellite spin rate, but lines are recorded for only 8 out of 10 drum rotations. Similarly, for the 1 by 1-nmi mode, the drum rate is 5 times the satellite spin rate with lines recorded for 4 out of 5 drum rotations. Under latter conditions, the facsimile recorder line advance mechanism must be able to be controlled independently of drum rotation. This capability is not, in general, available on most facsimile recorders and requires a special design such as is being developed by Image Information, Inc. (III) of Norwalk, Connecticut.

The final mode selected has 4 by 4-nmi resolution and employs approximately the full 288 degrees available for each line. With this mode, however, it is necessary to change the final image size. Since the drum and satellite rotation

rates are the same, it would require 360 degrees of video to write a line of the same size as for the other modes. A system constraint introduced by the III recorder is that 7/8 of each drum rotation contain video data. For the 4 by 4-nmi mode, this changes so that $(7/8)^2$ of the rotation contains video. Thus, in this case, the image is 7/8 normal size. This 4 by 4-nmi mode is capable of being used for either visible or IR data.

Note that in all modes the 4 by 2-nmi IR data are transmitted in the same manner. Four retransmission modes are defined in Table 6-12 in terms of their data content. Figure 6-35 illustrates the typical stretched video formats for a nominal satellite spin rate of 100 rpm.

Table 6-12

Retransmission Modes

Mode	Sensor	Resolution	Bits/Sample
A	V	1/2 x 1/2	6
B	V	1 x 1	6
C/D	V or IR	4 x 4	8
All modes	IR	4 x 2	9

The 4 by 2-nmi IR data use 9 bits per sample of which the most significant bit is set to logic ONE to denote the presence of an overlay dot. These overlay dots may represent the elements of a grid, for example.

6.13.3.3 Image Format

The organization of the normal frame output is shown in Figure 6-36 and is independent of the stretched-video transmission mode. As shown, the image width corresponds to $18 \frac{3}{8}$ degrees. At the top of the picture there are three scan lines corresponding to scans 3, 4, and 5, where scan 1 is defined as the north limit. Scans 4 and 5 contain calibrate data, while scan 3 is a normal scan.

6.14 DIRECT READOUT GROUND STATION (DRGS)

The DRGS has been developed to provide ground terminal facilities for receiving, recording, and displaying the visible and infrared data collected by the very high resolution radiometer (VHRR) of the ITOS and the VISSR data of the SMS.

MODE A 1/2 by 1/2	E	IR	V5	V6	V7	V8	V1	V2	V3	V4
	V									
	resolution	4 by 2				1/2 by 1/2				
	time interval	75 msec				60 msec				
	bits/sample	9				6				
bit rate	524,160				1,747,200 bits/sec					

MODE B 1 by 1	E	IR	V5-6	V7-8	V1-2	V3-4	
	V						
	resolution	4 by 2		1 by 1			
	time interval	95 msec		120 msec			
	bits/sample	9		6			
bit rate	524,160 bits/sec		436,800 bits/sec				

MODE C/D 4 by 4	E	IR	V1-8 or IR								
	V										
	resolution	4 by 2		4 by 4							
	time interval	75 msec		480 msec							
	bits/sample	9		8 (implanted grids)							
bit rate	524,160 bits/sec		33,280 bits/sec								

Figure 6-35. Stretched Video Format

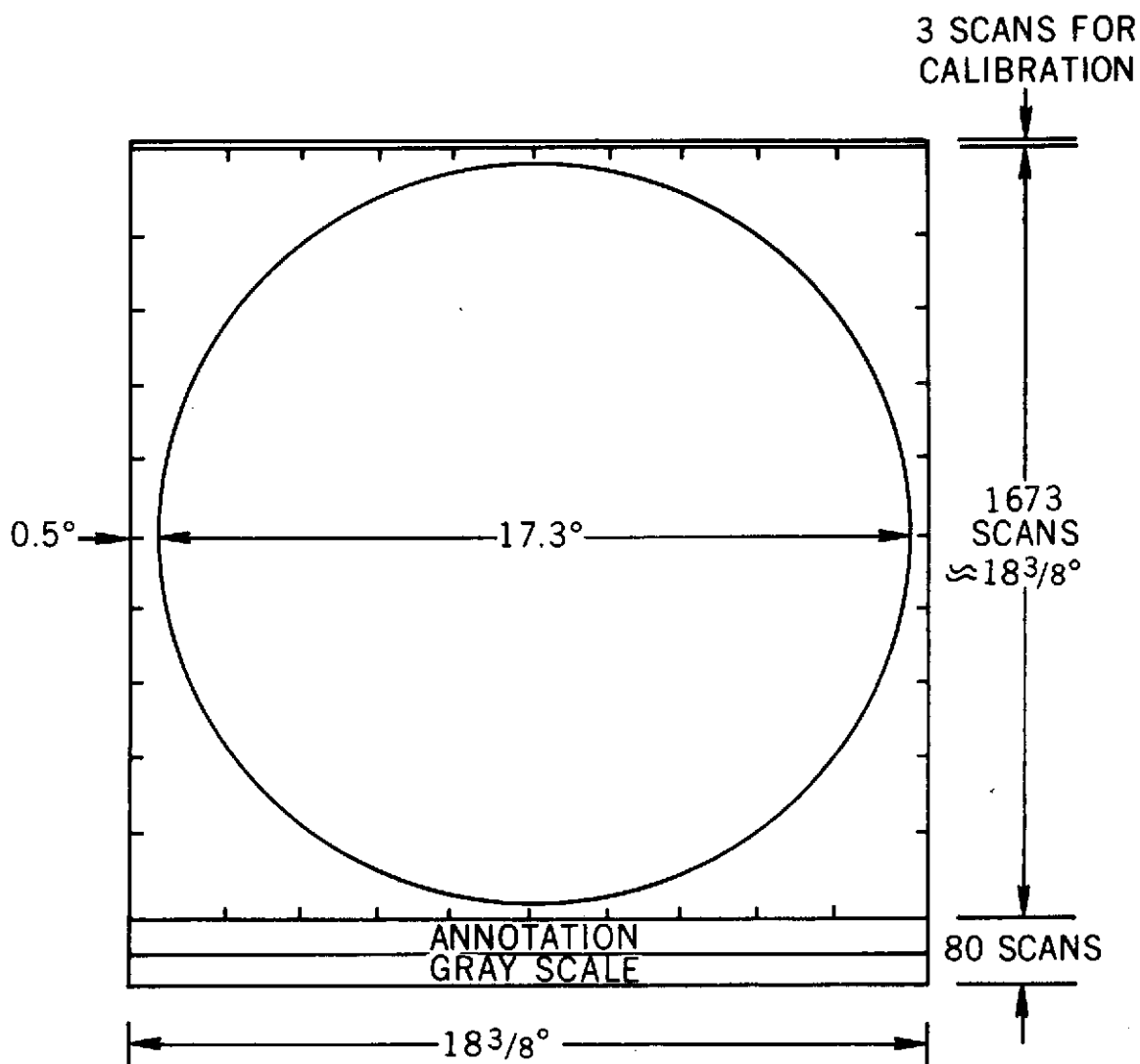

Figure 6-36. VISSR Image

The DRGS is a transportable receiving station, consisting of a flat-bed antenna trailer, (Scientific Atlanta 3200-R18) weighing approximately 26,500 pounds, and a 30-foot instrumentation van with a maximum gross weight under 16,000 pounds (tire limitation).

The DRGS will be located at the Wallops CDA station for a period of time prior to and following the launch of SMS, for spacecraft/ground system evaluation tests, and in the establishment of operational and procedural steps for optimum use of the data.

Upon completion of SMS operations support, the DRGS will be located at GSFC in the Network Test and Training Facility (NTTF) area in support of the ITOS satellites.

6.14.1 INSTRUMENTATION VAN

Figure 6-37 indicates the equipment layout for the instrumentation van. The van interior design provides facilities for work areas, storage space, safety features, and conveniences necessary for effective and efficient system operation.

6.14.1.1 Ceiling and Lighting

A false ceiling is provided to contain the required air conditioning exit and return ducts and the overhead lights. The overhead lighting fixtures are of the incandescent type with an on/off switch for each bank of six fixtures, with switches located on the wall by the personnel entry door.

A dry cell emergency lantern is provided close to the personnel door and at the main circuit breaker location. The emergency lights are wired to an on/off switch located near the personnel door. A 15-watt, 115-volt night light is also installed near the circuit breaker panel.

6.14.1.2 Walls and Floor

The van interior walls consist of 1/4-inch prefinished plywood. An air vent is provided on a side wall with a suitable flexible duct for connection to the heat exchanger rack.

A raised floor is provided to support the expected loads. Cable hangers are used for the underfloor cable installation. The cable hanger insures a minimum of 3 inches of clearance between the cable run and the van floor, and is installed at 2-foot intervals along the cable run. The floor surface above the cable run hangers is covered with removable floor panels.

6.14.1.3 Furnishings

Van interior furnishings are provided, and consist of the following items:

- Work bench
- Desk incorporating a photographic light table and storage drawers with latches to retain them in a closed position.
- Storage cabinets for maintenance tools and small parts.

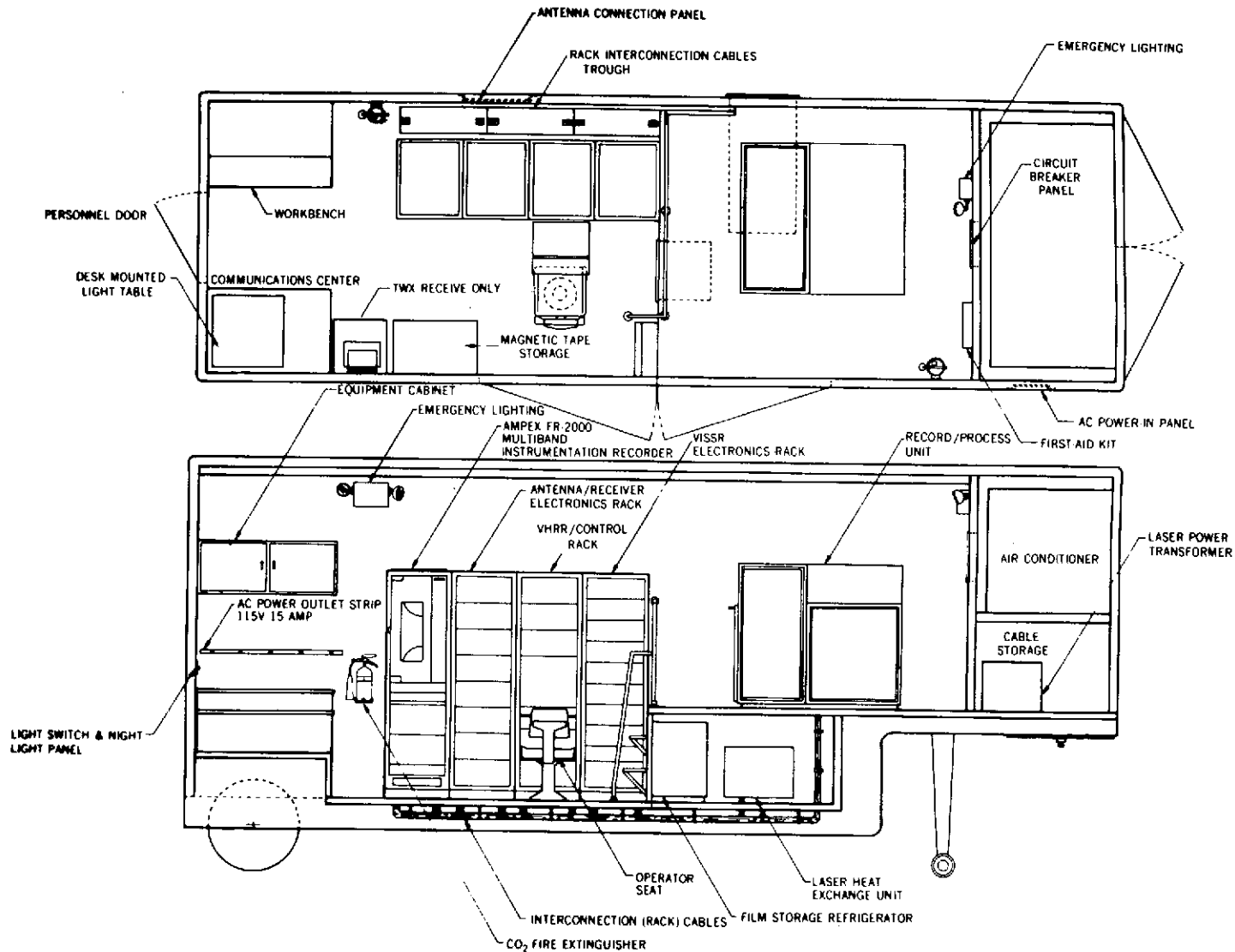

Figure 6-37. Direct Readout Ground System Instrumentation Van

- A refrigerator for film storage, with a capacity sufficient for a 30-day operation.
- Storage shelves are provided for approximately 200 reels of 1-inch magnetic tape.

6.14.1.4 Safety Equipment

An approved first aid kit is mounted in a conspicuous place and at a position for easy access. Fire extinguishers of the CO₂ type (electrical fire) are also provided.

6.14.1.5 Environmental Control Equipment

The electronic technical loads and lighting exceed 12 kw. The heat exchanger load of approximately 9kw is externally vented. Since it is desirable to maintain the ambient air at 72° F with outside temperatures of 100 to 110° F, and Ellis & Watts Model-EWMOAC7 air conditioner is provided.

6.14.1.6 Electrical Power Distribution

The instrumentation van is designed to accept 208-volt, 3-phase power. Connection to the van is made by means of two Russel Stoll male connectors, 3138 W Type FC, housed in a weatherproof recessed housing. One connector is used for utility power and the other is used for technical power. The utility power is brought to a main contactor and fused for a maximum of 15kw. From there it is routed to a circuit breaker panel which distributes the lighting load to two separate banks of lights, and through another circuit breaker to supply auxiliary AC power to outlets located within the van. The technical power connector is brought to a main power contactor fused at a maximum of 20kw. One phase of the 3-phase input technical load is connected to a step-up transformer capable of delivering 35 amperes to the laser/heat exchanger racks through a circuit breaker. The other phases are evenly loaded to provide 120-v AC power to each of the five equipment racks. Each equipment rack receives power through a circuit breaker terminated in a female three-prong heavy-duty AC receptacle at the rear of each rack. Provisions are made for AC hookup to base power for both auxiliary and technical load at a distance of 200 feet.

6.14.2 ANTENNA TRAILER

The flatbed antenna trailer system, Figure 6-38, is designed to provide a firm foundation or operating platform during operations with the spacecraft, and to provide storage and tie downs for the system's components during overland

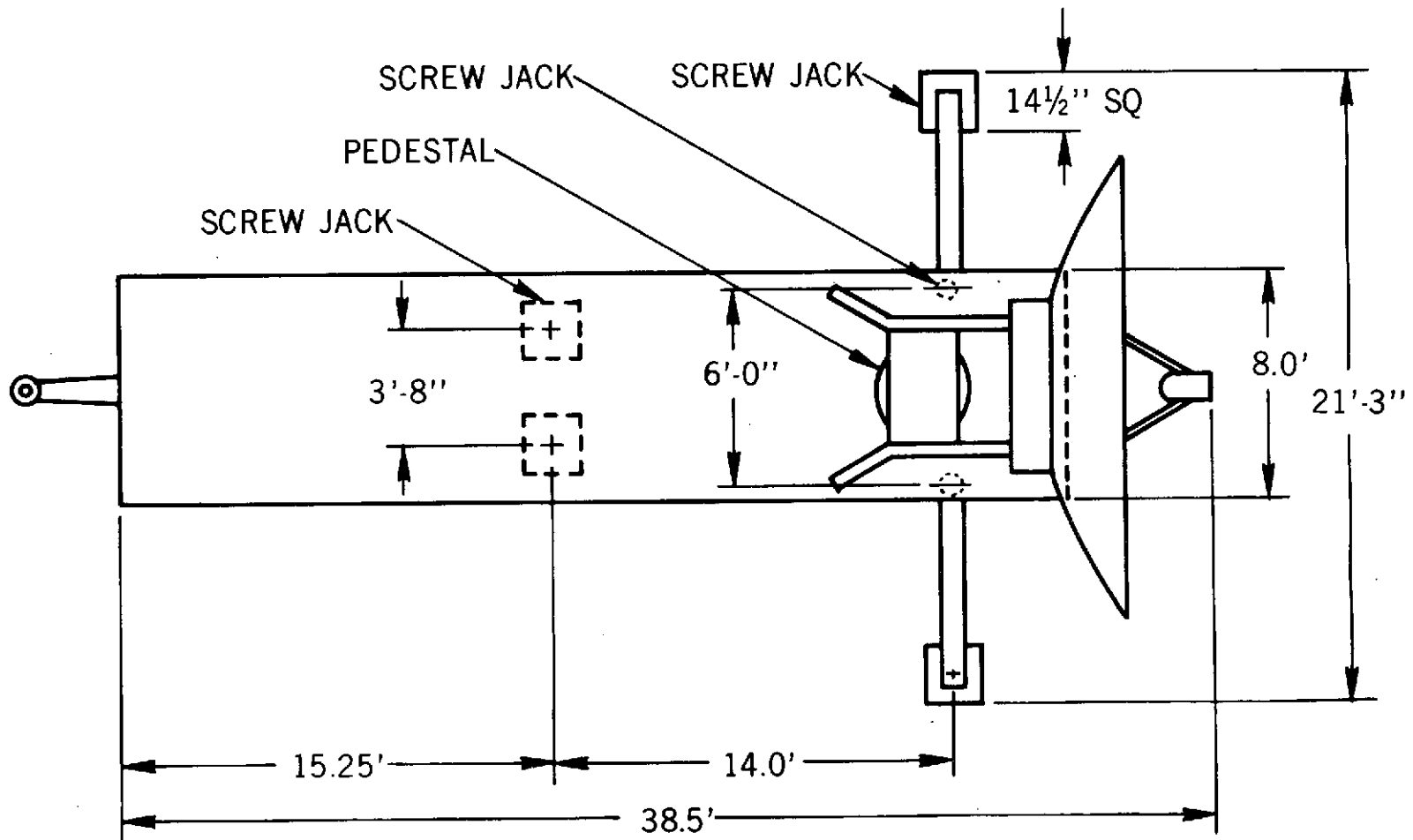

Figure 6-38. Direct Readout Ground System Antenna Trailer

transportation. The system comes complete with all necessary hand tools, ladders, space hardware and fasteners, tie-down straps, etc., to allow complete erection of the system from a transportable configuration to an operating configuration in a four hour period by a crew of four men. The trailer is used to support an 18-foot antenna, which comes apart in four pieces for transporting, and the feed system which is packaged in a fifth container.

6.14.2.1 Characteristics

The trailer body is constructed of heavy channel members, crossbraced to add support to the entire assembly. The trailer structure is reinforced at the pedestal tie-down points and the trailer deck is constructed of metal tread plate to provide safety for personnel.

While the system is performing a tracking mission, stability of the trailer is insured through the use of outriggers. These outriggers are easily swung into operating position from their stowed position on the side of the trailer by removing lock-down bolts.

The trailer is a two-axle design, with the rear axle being equipped with dual wheels. There are six 8.25 by 15 inch, 12-ply tires on the trailer. No spare is furnished.

The brake system is of the air-actuated type with air being furnished through air hoses (from the tow vehicle), which are supplied as part of the system. There are no brakes provided on the front axle.

All brake lines are flared to prevent leakage and all brake lines are mounted in rubber to prevent fatigue failure. A parking brake is supplied which may be manually operated.

Safety chains are provided. Road shock is minimized through the use of leaf springs on both front and rear axles. The rear axle is equipped with shock absorbers.

The trailer lighting system fully meets ICC regulations, and an electrical connector on the front of the trailer accepts power from the tow vehicle to operate the lamps.

6.14.2.2 Specifications

Weight: Empty	16,800 lbs
With antenna/pedestal	26,000 lbs

6.14.2.2 Specifications (continued)

Length:	33 feet
Width: Frame	4 feet
Overall	8 feet
Height: Deck	3 ft 4 inches
Overall (equipment stowed)	8 ft 8 inches
Ground clearance:	1 ft 2 inches
Turning radius: Tread	50 feet
clearance	55 feet
Wheel base:	30 feet
Track	6 ft 6 inches
Spring centers	4 ft 4 inches

6.14.2.3 Capabilities and Limitations

The trailer meets ICC regulations for normal over-the-road operation and may be towed without special permits. The trailer may be towed between sites with the equipment stowed at speeds up to 40 mph. The trailer and pedestal assembly is structurally capable of higher speeds, however, the recommended speed should be maintained whenever possible.

The trailer may be leveled on any terrain with a minimum soil bearing capacity of 2500 lb/sq ft and a maximum slope of 5 degrees.

With the system in the operating position and the azimuth and elevation axis stowed, the system withstands 60 mph winds. If winds exceed 80 mph, the pedestal must be lowered to the stowed position; however, the antenna may be left in place on the pedestal side arms. The antenna must be removed from the pedestal as if in preparation for transit if winds exceed 120 mph.

6.14.3 SYSTEM DESCRIPTION

The DRGS (Figure 6-39) is a versatile system designed to receive and record stretched VISSR and VHRR data in various operational modes. The three major subsystems are:

- Antenna/pedestal assembly

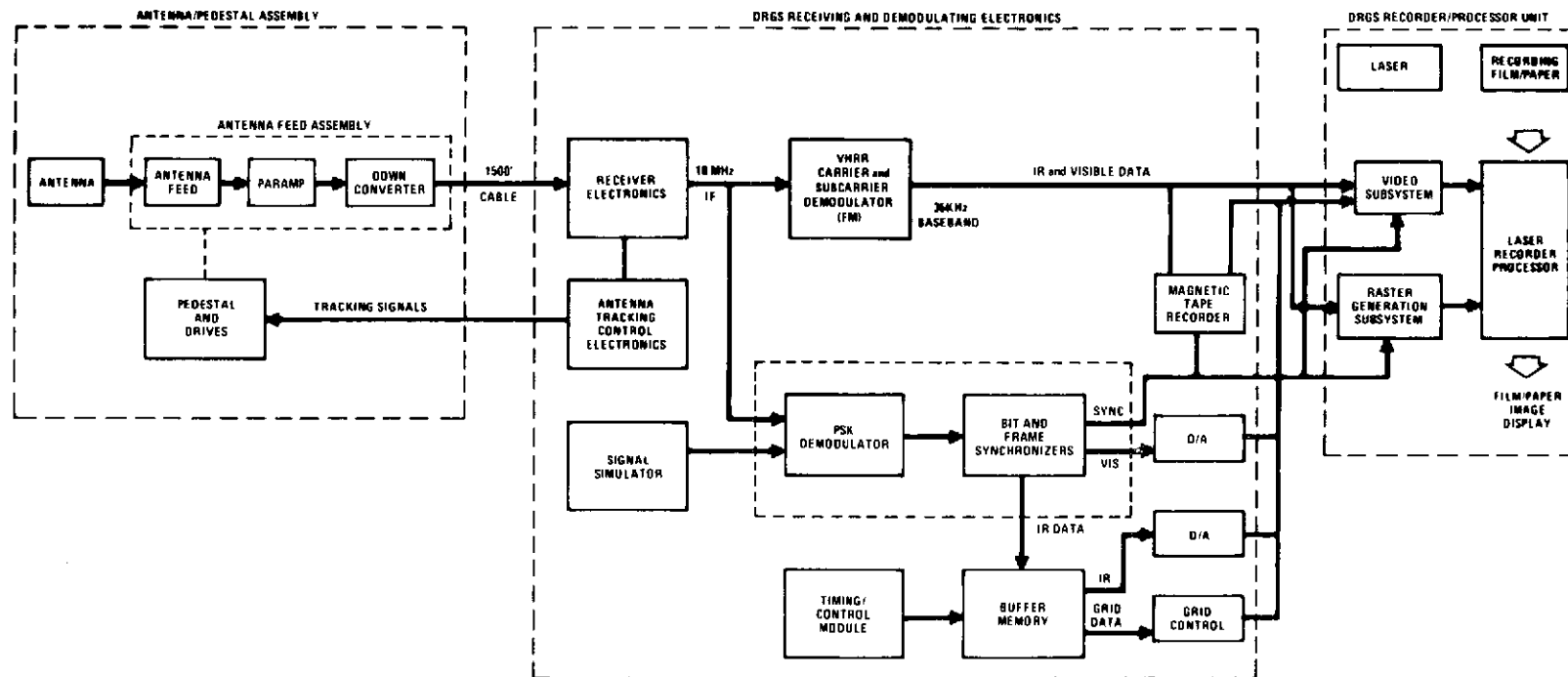

Figure 6-39. Direct Readout Ground System, Block Diagram

- Receiver and demodulating electronics
- Recorder/processor display subsystem

6.14.3.1 Antenna/Pedestal Assembly

The antenna/pedestal assembly consists of a solid surface parabolic reflector 18 feet in diameter, a parametric amplifier and down-converter mounted in the feed assembly, and the pedestal. The antenna/pedestal assembly is designed for operation over a range of environmental conditions that are expected at remote station sites, and can be located up to 1500 feet from the recorder/processor subsystem to facilitate site planning.

6.14.3.2 Receiving and Demodulator Processing

The receiving and demodulating electronics provides facilities for data receiving and demodulation of the stretched VISSR data that are received from SMS. The RF signal is received by the antenna and fed to a parametric amplifier by a single-channel monopulse feed assembly. The RF signal is down converted, and fed to the receiver over a coax cable. The receiver down converts the RF through two IF stages to a 10-MHz IF frequency. For SMS stretched VISSR reception, the IF signal is fed to a PSK demodulator which outputs a serial-bit stream to the bit and frame synchronizers. The IR data are directed to a core storage module and then read out for image recording purposes. The visible data are fed directly to the D/A converters, and then to the recorder/processor's video electronics. Grid data is extracted from the IR channel and used to grid both IR and visible image displays. Synchronization is extracted from the two channels of data and is used to synchronize the recorder's raster generating electronics.

6.14.3.3 VISSR Demodulation and Synchronization Electronics

The function of the VISSR demodulation and synchronization electronics is to convert the PSK/PCM signal from the receiver to an analog video signal, and to detect the transmitted sync signals for use by the recorder for synchronization. The system generates biphase PSK-NRZS demodulation and subsequent conversion to a word serial output accompanied by a number of synchronization signals.

The digital interface electronics system configuration is shown in Figure 6-40. It utilizes a special 10-MHz PSK Demodulator, two standard EMR signal conditioners (bit synchronizers), with four standard selector modules, in conjunction with a pattern recognizer/correlator (frame synchronizer) subsystem

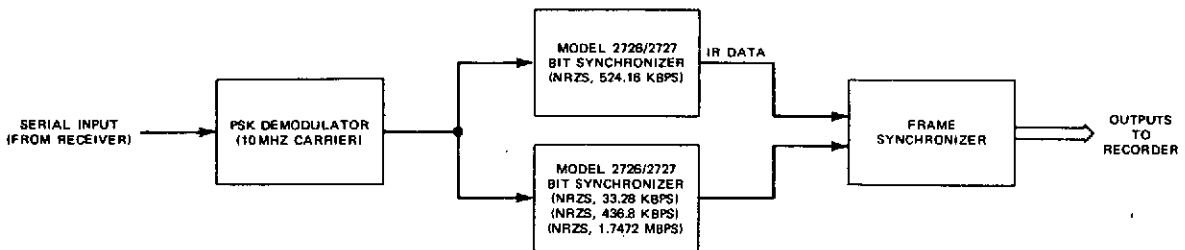

Figure 6-40. Digital Interface Electronics System Configuration

especially designed to optimize frame synchronization for the specified formats. The system also provides a complete self-contained interface between the receiver and the recorder/processor.

The serial, biphase, PSK, NRZS signal from the receiver is accepted by a special PSK demodulator capable of demodulating a 10-MHz PSK carrier and providing a serial PCM NRZS bit-stream output. This signal is routed to two EMR Model-2726/2727 bit synchronizers for further conditioning. One bit synchronizer is equipped with a selector module fixed at the IR data rate (524.16 kbps). A second bit synchronizer is provided which accepts one of the three visible-data selector modules. Each bit synchronizer accepts the serial NRZS signal and provides a noise-free serial NRZ-L output, accompanied by bit-rate clock pulse trains. The bit-synchronizer outputs are routed to the special frame synchronizer which performs word and frame (line) synchronization and serial-to-parallel data conversion. The frame synchronizer data and timing outputs are then routed to the recorder.

The input characteristics are:

Data transmitted	VISSR visible/IR data
Modulation	Bi-phase PSK NRZ-S
Carrier frequency	10 MHz
Bandwidth	6 MHz
Bit rates	Mode A - 1.7472 MBPS (visible) 524.16 KBPS (IR)
	Mode B - 436.8 KBPS (visible) 524.16 KBPS (IR)
	Mode C - 33.28 KBPS (visible) 524.16 KBPS (IR)

Number of words per line:

1672 6-bit words sync + 512 6-bit words documentation +
15,288 6-bit words video mode A (visible)

836 6-bit words sync + 256 6-bit words documentation +
7,644 6-bit words video mode B (visible)

69 8-bit words sync + 16 8-bit words documentation +
1,911 8-bit words video mode C (visible)

418 9-bit words sync + 128 9-bit words documentation +
3,822 9-bit words video All modes (IR)

A line is defined as the data interval containing sync, documentation, and video.

The above bit rates are based on a 100 rpm nominal spacecraft spin rate. The actual spin rate, however, may lie between -50 and 110 percent of the nominal value. The number of words per line remains constant but bit rates are determined by the eventual spacecraft spin rate. For example, the 1.7472-MBPS bit rate may end up to be as high as 1.92 MBPS or as low as 800 KBPS. The digital interface electronics has the capability to cover the bit-rate ranges of all three modes. The units may consist of interchangeable modules, selected on the basis of operating modes (A, B, or C) and the actual bit rate.

6.14.3.4 Signal Simulator

A signal simulator is provided as part of the digital electronics, capable of generating selectable signals i. e. , frequency burst, 16-levels gray scale, and horizontal bar patterns. The bar patterns have line groupings of 1, 2, 4, and 8 lines. The frequency bursts have provisions for data word groupings of 1, 2, 4, and 8 words. The output of the simulator is a PSK-modulated 10-MHz carrier. There is the capability of adding Gaussian noise and for accepting externally generated RF carrier and bit-rate inputs. The simulator design allows the operator to select fixed value (constant level) or 6-bit counting sequence where each word increases counter by one. A PN generator is also provided to generate the PN sequence employed in the initial sync period.

6.14.3.5 Frame Synchronization

The initial sync interval consists of a portion of a pseudonoise (PN) sequence generated by a 15-bit feedback shift register. This register fills to 15 one's with the transmission of the last sync bit prior to the first documentation word. This sequence is used for all formats. Feedback taps are at bits 8 and 15 (MSB) of the shift register.

6.14.3.6 Data Randomization and Word Complimenting

Documentation and video data are randomized (selectable) at the transmitting end by combining them with the output of the PN generator in an exclusive OR gate. In addition, every other word of data (documentation and video) are complimented (the first word in the documentation is sent un-complimented). The DRGS equipment has provisions to recover the original data from the randomized and complimented data stream.

6.14.4 RECORDER/PROCESSOR

The image recorder/processor subsystem consists of a laser drum recorder with an associated rapid-access dry processor. The raster coverage of the total drum surface is produced by coordinated indexing of an optical carriage upon which is mounted the spot-forming optics. The recorder/processor achieves recording spot size, density levels, and geometric fidelity through the combination of a precision drum-scanning and laser-light modulation system. The film processing is achieved through the controlled application of heat. The processor provides automatic transfer of the film from the recorder drum to the processor, and automatically ejects the processed image. Since the film is automatically loaded onto the recorder drum from a supply cassette, operation of the system is fully automatic at normal room temperatures. A summary of the design parameters for the recorder/processor when operating with the stretched VISSR data formats are:

Recording paper/film size	22 by 2 inches
Film type	3M Type 7869
Paper type	3M Type 774
Number of $\sqrt{2}$ density levels	16 (film) 12 (paper)
Optical spot sizes	1 1/2, 2 1/4, 3, 4 1/2, and 12 mils
Recording time/picture frame	20 minutes
Processing time/picture frame	4 minutes
Scan rate	50 to 1100 lines/minute
Resolution	14,000 elements/line
Laser source	Argon
Laser collant	Water