

**NASA CONTRACTOR
REPORT**



NASA CR-2424

NASA CR-2424

**AN ECONOMIC ASSESSMENT
OF STOL AIRCRAFT POTENTIAL
INCLUDING TERMINAL AREA
ENVIRONMENTAL CONSIDERATIONS**

Volume I

by H. L. Solomon and S. Sokolsky

Prepared by

THE AEROSPACE CORPORATION

El Segundo, Calif.

for Ames Research Center



NATIONAL AERONAUTICS AND SPACE ADMINISTRATION • WASHINGTON, D. C. • MAY 1974

1. Report No. NASA CR -2424		2. Government Accession No.		3. Recipient's Catalog No.	
4. Title and Subtitle "An Economic Assessment of STOL Aircraft Potential Including Terminal Area Environmental Considerations" Volume I				5. Report Date MAY 1974	
				6. Performing Organization Code	
7. Author(s) H. L. Solomon and S. Sokolsky				8. Performing Organization Report No.	
9. Performing Organization Name and Address The Aerospace Corporation El Segundo, California				10. Work Unit No.	
				11. Contract or Grant No. NAS 2-6473	
12. Sponsoring Agency Name and Address National Aeronautics and Space Administration Washington, D.C.				13. Type of Report and Period Covered Contractor Report Final Report	
				14. Sponsoring Agency Code	
15. Supplementary Notes					
16. Abstract This report presents the results of an economic and environmental study of short haul airline systems using short takeoff and landing (STOL) aircraft. The STOL system characteristics were optimized for maximum patronage at a specified return on investment, while maintaining noise impact compatibility with the terminal area. Supporting studies of aircraft air pollution and hub airport congestion relief were also performed. The STOL concept specified for this study was an Augmentor Wing turbofan aircraft having a field length capability of 2,000 ft. and an effective perceived noise level of 95 EPNdB at 500 ft. sideline distance. Commercial operation was simulated between major city pairs of the California Corridor, Midwest Triangle and Northeast Corridor in the 1980 time frame. Results are published in 2 volumes. Volume I presents an economic and environmental assessment of the defined STOL system and a summary of the methodology, STOL system characteristics and arena characteristics. Volume II amplifies the description of the methodology, STOL system characteristics and arena characteristics, and presents supplemental results of economic simulations at the city-pair level. Results show that economic viability can be achieved with vehicle capacities between 100 and 200 passengers with essentially the same level of patronage. A patronage drop of 35% was realized for 50 passenger vehicles. Significant increases in air travel were obtained in the Midwest Triangle and Northeast Corridor, but not in the California Corridor which currently has lower intrastate air fares. At 95 EPNdB, the STOL aircraft had no difficulty maintaining noise compatibility with land adjacent to the air fields. The improved engine technology yielded significantly lower air pollution than is realized with current aircraft.					
17. Key Words (Suggested by Author(s)) Short-Haul Air Transportation STOL Aircraft STOL Economics STOL Environmental Impact			18. Distribution Statement UNCLASSIFIED-UNLIMITED CAT.02		
19. Security Classif. (of this report) UNCLASSIFIED		20. Security Classif. (of this page) UNCLASSIFIED		21. No. of Pages 124	22. Price* 4.50

AN ECONOMIC ASSESSMENT OF STOL AIRCRAFT
POTENTIAL INCLUDING TERMINAL AREA
ENVIRONMENTAL CONSIDERATIONS

VOLUME I

SECRET No. 1150-1-19-11-11-11

Page Intentionally Left Blank

FOREWORD

This report is published in two volumes. Volume I presents the findings in seven sections:

Summary

Introduction

Approach

STOL System Characteristics

Arena Descriptions

Results

Conclusions

Volume II contains appendices with supporting reference data and methodology as follows:

Appendix A: STOL System Characterization

Appendix B: Arena Characterization

Appendix C: Transportation System Simulation

Appendix D: Supplementary Results

Page Intentionally Left Blank

ACKNOWLEDGEMENTS

This study, performed for the Ames Research Center under NASA Contract No. NAS 2-6473, is part of the NASA study of V/STOL aircraft applications as a possible means of solving the growing air transportation problems in the U. S. The present study evaluated the economic viability and environmental compatibility of STOL service in short haul high density arenas. Appreciation is extended to Mr. George Kenyon and Mr. Elwood Stewart, the NASA Technical Monitors of the study, for their assistance and guidance provided.

Particular acknowledgement of members of the technical staff of The Aerospace Corporation for valuable contributions is given to:

Richard W. Bruce
(Northeast Corridor data)

Jon R. Buyan and Larkin Veigel
(Transportation System Simulation development and production)

Leon R. Bush
(Arena characterization)

Paul K. Dygert^{*}
(Noise buffer zone cost programs)

Jesse H. Katz
(Noise and land use programs)

Walter J. Portenier
(Aircraft characteristics)

Hector Rodriguez
(Congestion analysis)

Wolfgang Roessler
(Pollution analysis)

Terry Schoessow
(Noise analysis)

Ronald M. Selter
(Economics)

* Consultant to The Aerospace Corporation

CONTENTS

I.	SUMMARY	1
II.	INTRODUCTION	3
III.	APPROACH	7
	A. Study Guidelines and Ground Rules	8
	B. Methodology	10
IV.	STOL SYSTEM CHARACTERISTICS	17
	A. STOL Aircraft Description	17
	B. STOLport Requirements	24
	C. Economics	26
V.	ARENA DESCRIPTIONS	33
	A. Region Descriptions	33
	B. Intercity Travel Demand	38
	C. Intercity Transportation Characteristics	38
VI.	RESULTS	55
	A. Parametric Sensitivities	55
	B. Selected System Definition	69
	C. Environmental Results	89
	D. Extended Range Application	108
VII.	CONCLUSIONS	113
	A. STOL Patronage Potential	113
	B. Principal STOL System Attributes	113
	C. Aircraft Size	114
	D. Fleet Requirements	114
	E. Extended Range Potential	115

CONTENTS (Continued)

F. Noise Impact	115
G. Air Pollution Impact	115
H. Hub Airport Congestion Relief	116
I. Open Issues--Aircraft Design Alternatives	116
REFERENCES	117
GLOSSARY	121

FIGURES

1.	Transportation System Simulation Application to STOL System Definition, Summary of Inputs and Outputs	7
2.	Transportation System Simulation Approach	12
3.	Noise Buffer Zone Cost Methodology	15
4.	General Arrangement, Two-Stream Augmentor Wing Aircraft	17
5.	Noise Characteristics, 150-Passenger Augmentor Wing Aircraft	22
6.	Comparative Emissions for 150-Passenger STOL and CTOL Aircraft	23
7.	Variation of Direct and Indirect Operating Costs	30
8.	California Corridor	34
9.	Midwest Triangle	35
10.	Northeast Corridor	36
11.	Los Angeles Region Port Locations	43
12.	San Francisco Region Port Locations	44
13.	San Diego Region Port Locations	45
14.	Sacramento Region Port Locations	46
15.	Chicago Region Port Locations	47
16.	Detroit Region Port Locations	48
17.	Cleveland Region Port Locations	49
18.	New York Region Port Locations	50
19.	Philadelphia Region Port Locations	51
20.	Boston Region Port Locations	52
21.	Washington, D.C., Region Port Locations	53

FIGURES (Continued)

22.	STOL Patronage, California Corridor	57
23.	STOL Patronage, Midwest Triangle	59
24.	STOL Patronage, Northeast Corridor	60
25.	Fare Structure, California Corridor	63
26.	Fare Structure, Midwest Triangle	64
27.	Fare Structure, Northeast Corridor	64
28.	Comparison of Arena STOL Demand Sensitivities	66
29.	Fleet-Size Requirements, California Corridor	68
30.	Fleet-Size Requirements, Midwest Triangle	68
31.	Fleet-Size Requirements, Northeast Corridor	69
32.	CTOL Block Speed Comparisons	77
33.	CTOL Fare Comparisons	77
34.	STOL and CTOL Comparisons	78
35.	CTOL and STOL Fare Comparisons, New York-Washington City Pair	80
36.	STOL Impact on Other Northeast Corridor Modes	88
37.	Effective Perceived Noise Level Contours	89
38.	General Aviation Aircraft Noise Characteristics	92
39.	Fullerton Airport Noise Analysis	93
40.	Secaucus STOLport Noise Analysis	97
41.	Aviation-Produced Emissions, California Corridor	101
42.	Aviation-Produced Emissions, Midwest Triangle	101
43.	Aviation-Produced Emissions, Northeast Corridor	102

FIGURES (Continued)

44.	Peak-Hour Passenger Factor	105
45.	Chicago-New York STOL Air Demand	110

TABLES

1.	Aircraft Block Performance	19
2.	Extended Range Aircraft Parameters	20
3.	STOL Aircraft Production Base and Unit Costs	27
4.	Regional Data Sources and Socioeconomic Characteristics	37
5.	California Corridor and Midwest Triangle Demand Data Summary	39
6.	Northeast Corridor Demand Data Summary	40
7.	1980 Mode Characteristics	41
8.	STOL System Economic Viability Comparison	56
9.	Optimum Number of STOL Service Paths, California Corridor	58
10.	Optimum Number of STOL Service Paths, Midwest Triangle	61
11.	Optimum Number of STOL Service Paths, Northeast Corridor	62
12.	Selected STOL System Service Characteristics, California Corridor	71
13.	Selected STOL System STOLport Requirements, California Corridor	72
14.	Selected STOL System Service Requirements, Midwest Triangle	74
15.	Selected STOL System STOLport Requirements, Midwest Triangle	74
16.	Selected STOL System Service Characteristics, Northeast Corridor	75
17.	Selected STOL System STOLport Requirements, Northeast Corridor	76

TABLES (Continued)

18.	Selected STOL System Fare Comparison	79
19.	Selected STOL System Potential, 150-Passenger Vehicle, ROI = 8 Percent	82
20.	STOL Service Impact, California Corridor	83
21.	STOL Service Impact, Midwest Triangle	85
22.	STOL Service Impact, Northeast Corridor	86
23.	General Aviation Aircraft Flight Characteristics	91
24.	STOLport Operations, California Corridor	94
25.	STOLport Operations, Midwest Triangle	96
26.	STOLport Operations Northeast Corridor	97
27.	Noise Sensitivity to Aircraft Operations	99
28.	Noise Sensitivity to Flight Path	99
29.	Comparison of Aircraft Exhaust Emissions at Air Terminals	103
30.	Effect of STOL Service Introduction of CTOLport Congestion	108
31.	1980 Chicago-New York CTOL Service	109
32.	Chicago-New York Demand	109
33.	Extended Range STOL System Characteristics, 150-Passenger Vehicle, ROI = 8 Percent	111

I. SUMMARY

This report presents the results of an economic and environmental study of 1980 short haul airline systems using short takeoff and landing (STOL) aircraft. The purpose of the study was to evaluate the ability of STOL aircraft to produce economically viable and environmentally compatible systems in order to provide guidance to appropriate National Aeronautics and Space Administration (NASA) aircraft research and development programs. The candidate STOL aircraft concept chosen by NASA for the study was an Augmentor Wing turbofan aircraft having a hot day balanced field length capability of 2000 feet. Assessing the impact of an effective perceived noise level of 95 EPNdB at a 500-foot sideline distance was a significant factor in the study approach. Commercial operation of the aircraft was simulated between major city pairs of the California Corridor, Midwest Triangle, and Northeast Corridor.

For the most part, the STOL system utilized either existing general aviation airports or dedicated STOLports. This feature, coupled with the high maneuverability of the aircraft, allowed the operation of STOL to take place in "dedicated airspace" where interactions with other air systems were minimal. Adverse community noise impact was precluded in the STOL system by changing land use as necessary in the affected area. The costs of creating such buffer zones, as well as any new airfields or terminals required to support the service, were fully borne by the STOL system and ultimately passed on the travelers in the form of higher fares. Projected 1980 conventional takeoff and landing (CTOL) service was assumed to operate with current block times (i. e., with existing levels of congestion). Rail service in the Northeast Corridor was upgraded to the Interim High-Speed Rail System-Option 1 defined by the Northeast Corridor Transportation Project.

Maximum STOL patronage was attracted when using the largest vehicle examined (200 passengers). Less than a 10-percent reduction in demand was

observed when operating with vehicle capacities as low as 100 passengers, but this grew to a 35-percent reduction for the smallest vehicle (50 passengers).

A STOL system based upon the use of 150-passenger vehicles and attaining an 8-percent return on investment (ROI) produced a 6-percent increase in short haul origin and destination air travelers (STOL plus CTOL) within the California Corridor, a 66-percent increase in the Midwest Triangle, and an 88-percent increase in the Northeast Corridor. The STOL system attracted over 95 percent of the origin and destination air travelers between the major city pairs of the Northeast Corridor and Midwest Triangle and 50 percent of the air travelers between the three economically viable city pairs in the California Corridor. These differences stem principally from the more competitive time and cost attributes of the California intrastate CTOL air service.

Extending the range of the STOL aircraft by increasing fuel capacity and compensating for the increased fuel and tankage weight by carrying fewer passengers appears to be commercially attractive and could offer a significant addition to what otherwise might be a marginal production base.

At its defined noise level, the STOL aircraft had no difficulty maintaining compatibility with the noise limitations predicated on the land use adjacent to its airfields. Reflecting the improved engine technology imbedded in the design, the aircraft produce significantly lower quantities of air pollutants than do current CTOL aircraft. Operations out of local airports, in addition to offering decidedly better access to the air traveler, also reduce CTOL congestion and would permit delays in facility expansion at major hub airports.

II. INTRODUCTION

The National Aeronautics and Space Administration (NASA) has conducted a series of studies of advanced aircraft concepts to better serve the short haul, high-density air carrier markets of the United States. These studies have been responsive to:

- The growing restriction to air travel being imposed by congestion both in the air and on the ground at terminal areas.
- The adverse environmental impact of aircraft operations on the surrounding community.

One element of this program was an examination of STOL aircraft utilizing quiet propulsive-lift concepts. STOL aircraft concepts investigated include the Mechanical Flap, Over-the-Wing, Externally Blown Flap, and Augmentor Wing configurations covering a range of hot day balanced field length capabilities from 4000 to 1500 feet.

In parallel with investigations of the technology, design, and cost of these concepts by airframe and engine manufacturers, Aerospace conducted an independent economic and environmental assessment of candidate STOL aircraft concepts in scheduled air carrier service along high-density, short haul routes. The first-year activities of this effort encompassed three concepts operating in two arenas (the California Corridor and Midwest Triangle), and included only economic assessments. The results of the initial effort were published in an interim study report given limited distribution in July 1972 (Refs. 1 and 2). These initial efforts included:

- Development of necessary demographic and travel data.
- Definition of economic characteristics of baseline design concepts.
- Development of design tradeoff information to enable evaluation of economic impact of design variations.

This document reflects a broadening of the analysis to include an examination of aircraft noise and a determination of the resulting impact on STOL system economic viability. Also included were supporting studies of aircraft

air pollution and hub airport congestion relief. Furthermore, the three candidate STOL aircraft concepts were narrowed to a single concept whose characteristics reflect more current design and cost characteristics obtained through NASA's airframe and engine design studies.

The objectives of the present study were to:

- Examine the impact of technological, economic, and operational characteristics of STOL transportation systems in selected arenas.
- Determine the economic viability of STOL airline systems required to absorb the full cost of achieving environmental noise compatibility.
- Provide guidance to NASA on STOL research and development programs by evaluating, in realistic operating scenarios, the significance of technological advances in noise suppression as well as propulsive efficiencies embodied in the representative STOL aircraft concept.

The STOL aircraft concept furnished by NASA for this study was an Augmentor Wing turbofan-powered aircraft having a hot day balanced field length capability of 2000 feet. The engines were based on characteristics developed in the quiet, clean STOL engine technology program. An overall noise goal of 95 EPNdB at a 500-foot sideline was set for the aircraft. In order to maximize congestion relief at hub airports, as well as to evaluate the quiet-engine technology in its most severe environment, the study avoided the use of hub airports to the greatest extent possible and maximized the use of general aviation community airports located close to centers of demand. New STOLports were constructed only where they were essential to support high-density routes and where the full cost of their development and operation could be underwritten by the revenue potential of the STOL system. The latter was assumed to be implemented completely as a free-enterprise venture. No cost sharing was assumed for the development of facilities required to support STOL operations [except for Federal Aviation Administration (FAA)-furnished air traffic control facilities necessary for flight safety], but neither was the STOL system required to support unprofitable low-density service with the revenues obtained from the more profitable routes. To provide

additional variations in regulatory environments and demographic, economic, and travel patterns, as well as in competing transportation modes, the Northeast Corridor was added to the California Corridor and Midwest Triangle arenas.

Results of this study are published in two volumes. Volume I presents the results of the economic and environmental assessment of the defined STOL airline system, together with a summary of the methodology, STOL system characteristics, and arena characteristics used as the basis of the study. Volume II (Ref. 3) contains appendixes amplifying the description of the methodology, STOL system characteristics, and arena characteristics. It also presents supplemental results on a city pair level along with additional parametric system descriptions corresponding to other combinations of return on investment (ROI) and vehicle size.

Page Intentionally Left Blank

III. APPROACH

The approach adopted for this study optimized STOL system characteristics for maximum patronage at a specified return on investment (ROI), while maintaining noise impact compatibility with the terminal area. This was accomplished through use of the Aerospace Corporation's Transportation System Simulation (TSS), which not only takes into account performance, noise, and cost characteristics of the study aircraft but also the environment in which the air service is to operate (i.e., land use in the terminal area, characteristics of the competing modes, and demographic and income distributions within the arena). The costs of airport expansion required by the STOL air carrier--be they airfield, terminal, or noise buffer zone--were passed back to the air carrier in the form of higher landing fees or terminal rentals.

Examples of inputs to and outputs from the TSS are summarized in Figure 1. Of the five input quantities, three were varied parametrically in this study. STOL service was evaluated in three arenas; vehicle sizes were

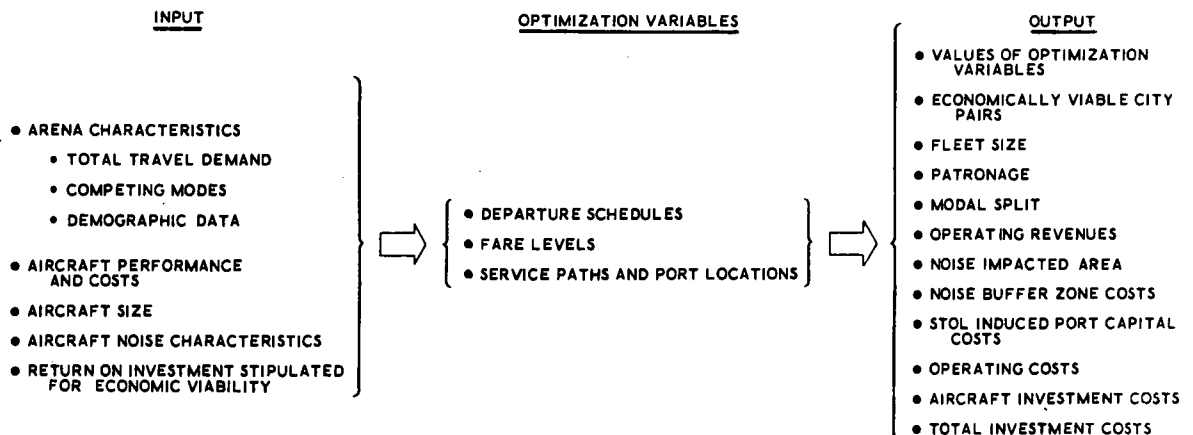

Figure 1. Transportation System Simulation Application to STOL System Definition, Summary of Inputs and Outputs

varied from 50 to 200 passengers in 10-passenger increments; and four values of ROI were examined.*

Multiple arenas were incorporated into the study to provide a diverse set of operating environments. Vehicle capacity and ROI were varied to derive sensitivities of the STOL service potential with respect to each of those parameters. In all, 192 sets of STOL system characteristics were defined, each specifically optimized for the given set of input variables. To focus the analysis on the study objectives and to better bound the scope of work, a number of guidelines and ground rules were adopted.

A. STUDY GUIDELINES AND GROUND RULES

Time Period. The 1980 time period was selected to be consistent with the minimum lead time required for the development and subsequent certification of a number of candidate STOL concepts. Market growth potential beyond 1980 was not incorporated into this study.

Arenas. The study examined STOL operations in three arenas defined as follows:

- California Corridor including Los Angeles, San Francisco, San Diego, and Sacramento.
- Midwest Triangle made up of Chicago, Detroit, and Cleveland.
- Northeast Corridor encompassing New York, Washington, D. C., Boston, and Philadelphia.

STOL Aircraft Concept. The Augmentor Wing concept, which has been widely analyzed through other NASA studies and experimental programs, was chosen as being operationally representative of STOL capabilities. The configuration selected had a design range of 500 statute miles and a hot day balanced field length capability of 2000 feet. The derivation of parametric

*The upper limit in the Midwest Triangle and Northwest Corridor was 12 percent; the upper limit in the California Corridor was 12.5 percent.

weight and performance characteristics as a function of vehicle capacity was based on point design data supplied by the NASA Ames Research Center.

STOLport Siting. Maximizing STOL patronage was the initial criterion for STOLport siting. The option was retained to relocate, if required to attain noise compatibility. Most STOLports were sited at existing general aviation airports. New STOLports were sited only when a potential existed for substantial increases in STOL travel demand.

Dedicated Airspace. The ability of STOL aircraft to approach and depart the airport along steeply inclined paths, coupled with the fact that STOLports were not colocated with CTOL hub airports,* led to the ground rule that STOL aircraft could operate in dedicated airspace independent of any congestion in the CTOL system.

Noise Impact Criteria. The Noise Exposure Forecast (NEF) technique was chosen to measure land use compatibility; NEF levels ≤ 30 , 35 and 40 were considered acceptable for residential, commercial, or manufacturing land uses, respectively (Ref. 4).

Dollar Basis. All costs were converted to and are expressed in 1970 dollars.

Criteria for Economic Viability. The operators annual ROI, calculated in accordance with the Civil Aeronautics Board (CAB) formula, was used as the measure of economic viability.

Competitive Mode Characterization. The projected characteristics of the 1980 competitive modes of transportation were assumed to be equivalent to those of current systems, with anticipated growth in demand accommodated by increased vehicle capacities or additional highways for the public and car

* Logan International was used as the primary Boston STOLport at the request of local planning agencies. A dedicated STOL runway at that facility may permit operations independent of the CTOL systems.

modes, respectively. Two exceptions were the increased operating frequencies on what are currently low-density CTOL service paths, and the assumed introduction of a new high-speed rail system (Interim High-Speed Rail-Option 1) in the Northeast Corridor (Ref. 5). These characteristics, having once been established, were not varied in response to implementation of the STOL service.

Maximum Average Load Factor. While the effects of diurnal demand distributions are considered in the system simulation, the effects of daily, weekly, or seasonal variations in demand were not incorporated in the approach. To offset the possibility of obtaining unrealistically high load factors, an average load factor upper limit of 65 percent was applied to each STOL service path.

Schedules. STOL schedules were uniform over the operating day, with first departure no earlier than 7:00 A.M. and last departure nominally occurring not later than 9:00 P.M. A minimum of four round trips per day was required on each service path.

Fares. STOL fares were permitted to seek levels that produced a specified ROI unencumbered by regulatory constraints. Fares on all STOL service paths serving the same city pair were constrained to a common value.

B. METHODOLOGY

After each arena was characterized, STOL aircraft characteristics determined, and desired ROI stipulated, schedules, fares, and service path combinations that optimized the STOL system were progressively determined. The interaction of elements used in this process is described in the following overview.

1. OVERVIEW

These steps are directly keyed to the flow diagram in Figure 2.

- ① The total demand and modal split programs are used in combination with arena characteristics to define STOL patronage, schedules, and fleet size requirements for each combination of service paths and fares. Schedules are adjusted to comply with a limit on the average daily load factor of 65 percent, which was selected to accommodate daily, weekly, and seasonal demand variations.
- ② The stipulated ROI is used to determine a one-way STOL fare for each candidate service path set postulated for each city pair.
- ③ The candidate STOL service path sets, which have been carried parametrically for each city pair, are compared and the set that maximizes patronage at the desired ROI is selected.
- ④ The arena aggregation process totals the number of STOL operations and STOL passengers at each port, including those common to more than one service path or city pair. This provides the basis for calculating a port-related indirect operating cost (Δ IOC), which is applied equally to each departure between all city pairs in an arena.
- ⑤ Port-related IOCs are computed for each STOLport as a function of aircraft size, number of STOL operations, and STOL passengers. The IOCs include STOL-induced port capital costs converted to either landing fees or terminal rentals, plus station operating costs. These data, together with STOL traffic levels at each STOLport, from Step ④, are used to derive a system-wide, port-related IOC per departure.
- ⑥ An estimated port-related IOC is inherent in and influences the computations of Step ②. An iterative procedure is used from Step ② through Step ⑤ until convergence between the estimated and derived values of port-related IOC is realized at the specified ROI.
- ⑦ The resulting STOL system characteristics (Figure 1) are identified and used in support of subsequent air pollution and hub airport congestion studies.

A summary of each of the key TSS programs is presented in the following paragraphs.

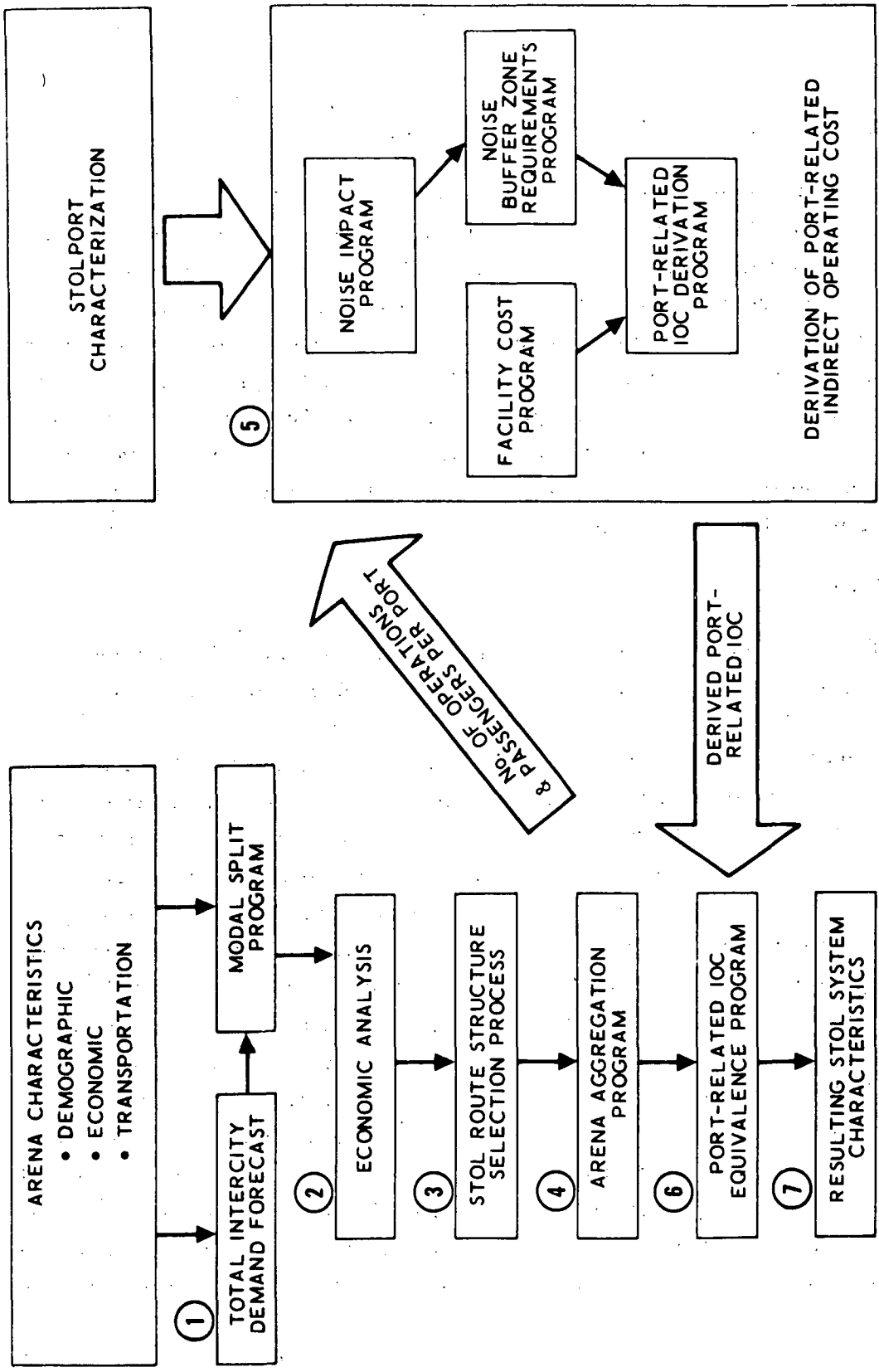

Figure 2. Transportation System Simulation Approach

2. TOTAL INTERCITY TRAVEL DEMAND

The approach assumes that changes in intercity travel demand from that found for a base year can be measured by changes in the product of the populations of the origin and destination regions. The credibility of this method is enhanced by the fact that the statistics utilized to determine actual intercity travel demand for a base year reflect all factors influencing demand between a city pair. This technique avoids the problems inherent in most gravity models, which typically consider only population product and distance while ignoring such important factors as the proximity of other cities and the induced travel influence of educational and governmental institutions, military facilities, and recreational attractions.

3. MODAL SPLIT

The division of total travel demand among the competing modes is determined by the modal split simulation. Travelers are individually simulated with a Monte Carlo technique which selects exact origin and destination location within a region, trip purpose, desired departure time, sensitivity to frequency of service, car ownership, trip duration, party size, time value, and modal preference factors. The latter factors account for the nonquantifiable (in terms of time or cost) elements of the modal choice decision process and are used to calibrate the model to the travel statistics for a known point in time. Distributions from which most of the traveler attributes are drawn are derived by utilizing projections of metropolitan area demographic and economic characteristics on a zonal basis, in combination with regional travel habit patterns extracted from the 1967 Census of Transportation Public Use Tape. For each simulated traveler, an "effective trip cost" is computed for all possible combinations of local (door-to-port and port-to-door) and intercity (port-to-port) transportation modes. Effective trip cost reflects total out-of-pocket expenses, door-to-door trip time, modal preferences, and traveler time values. The traveler is assigned to that combination of local and intercity modes which produces the minimum effective trip

cost. The resulting allocation of all simulated travelers to their respective minimum effective-trip-cost modes produces the modal split.

Accuracy of the modal split results is directly related to the degree of realism achieved when characterizing the arena, its travelers, and the transportation system alternatives. Considerable effort was directed toward identifying and quantifying characteristics that will have an impact on a traveler's mode choice. These include port location, port processing time, port parking time and cost, local travel time and cost, and the intercity travel time, cost, and frequency of service as a function of mode and service path.

Random samples from probability distributions, rather than averages, are employed to establish traveler attributes. This technique results in a realistic representation of intercity travelers, including not only characteristics identifying "typical" travelers, but also simulating "atypical" travelers, such as:

- Large families (party size) that are motivated to use private cars rather than pay the multiple fares required for use of the common carriers.
- Individuals who just won't fly regardless of the possible time and cost benefits associated with an air mode.
- Rail buffs who will take the train at almost any cost.
- Travelers who don't own or have access to a car and are therefore forced to use a common carrier.

Such characteristics are included in an attempt to reflect "real world" conditions. The modal split procedure is not masked by complex mathematical expressions and is, therefore, easily accessible for detailed analysis.

4. NOISE BUFFER ZONE REQUIREMENTS AND COSTS

The creation of a noise buffer zone involving changes in land use is one method of ensuring that noise levels attributable to STOL system operations are compatible with the environment. Figure 3 illustrates the methodology used to determine the necessity and cost to create such a zone.

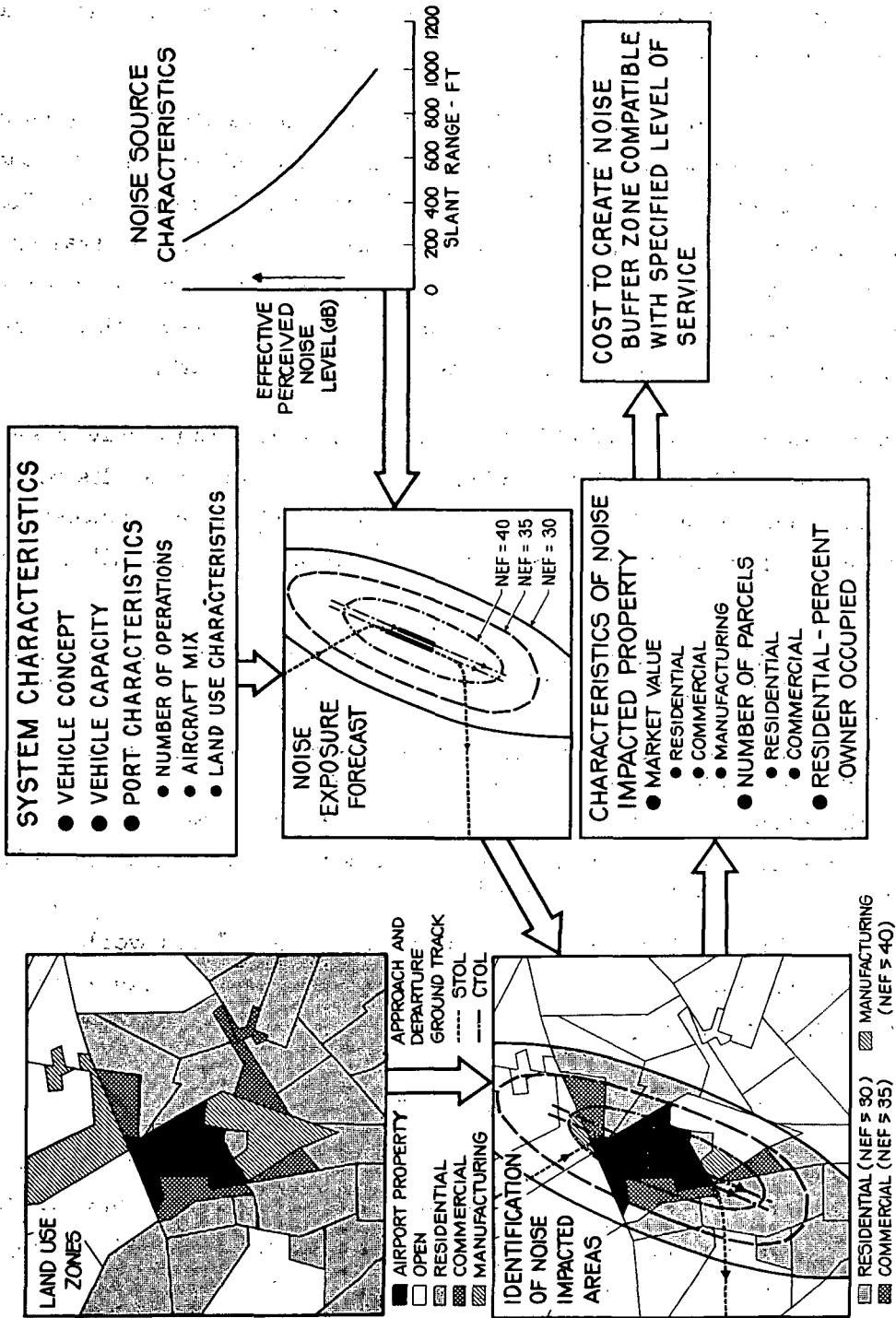

Figure 3. Noise Buffer Zone Cost Methodology

A computer model depicting the geometry and value of land parcels in the vicinity of airports was utilized to assign numbers and values to noise-impacted land areas. The model directly interfaces with an Aerospace-modified Department of Transportation (DOT)/Transportation Systems Center program used to derive the coordinates of NEF contours. In essence, these NEF contours are "overlaid" onto the stored land-use model, and intersections between the NEF contours and corresponding coordinates on land parcels are determined. Thus, the adversely impacted areas, (i. e., those areas of each affected land parcel contained within the prescribed NEF contour) are computed and their dollar value determined from the cost-per-acre data stored for each land parcel. The results are port dependent, since no two ports have similar boundaries or surrounding land uses or identical levels of aircraft operations. Total costs are based on impacted property values as well as relocation expense, environmental impact studies costs, and project administration costs. The resulting investment is amortized in the form of higher landing fees and/or terminal rentals charged to the STOL system operator.

IV. STOL SYSTEM CHARACTERISTICS

A. STOL AIRCRAFT DESCRIPTION

The STOL systems defined in this study utilized a quiet powered-lift Augmentor Wing aircraft. NASA defined a family of such 4-engine aircraft in four sizes from 50 to 200 passengers. The general arrangement and pertinent physical characteristics of these aircraft are shown in Figure 4.

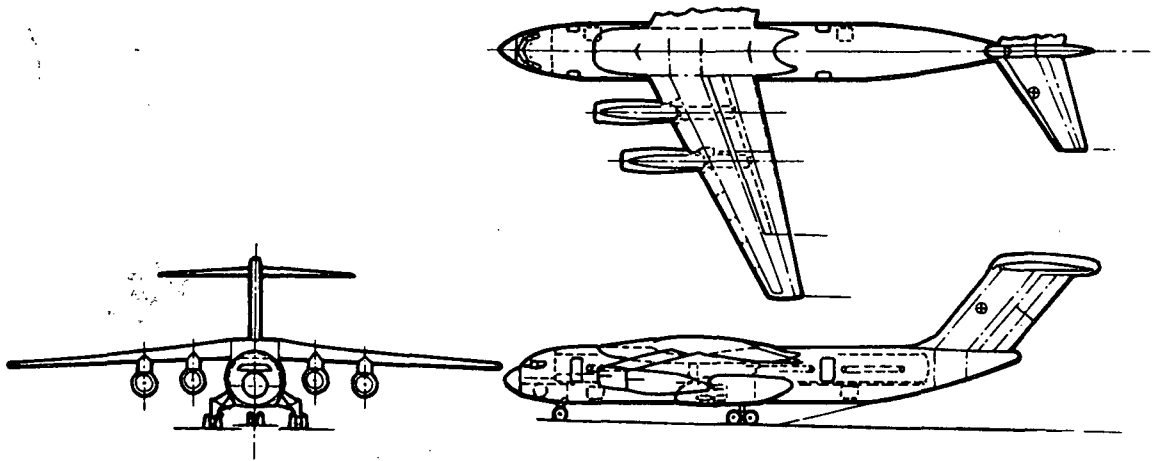

NUMBER OF PASSENGERS	50	100	150	200
FUSELAGE LENGTH, ft	70	105	132	159
FUSELAGE WIDTH, ft	12	14	14	14
WING SPAN, ft	69	94	112	128
OPERATING EMPTY WEIGHT, lb	34,710	61,927	87,324	113,408
PAYLOAD (w/o fuel), lb	11,000	22,000	33,000	44,000
TAKE-OFF GROSS WEIGHT, lb	54,801	100,000	142,782	186,169
THRUST/ENGINE, lb	5,875	10,715	15,300	19,950

Figure 4. General Arrangement, Two-Stream Augmentor Wing Aircraft

Aerospace interpolated the NASA-supplied data to define a family of aircraft sizes from 50 to 200 passengers in steps of 10 passengers. The hot day balanced field length was 2000 feet and the design range was 500 statute miles plus reserves.* Computations of performance characteristics for this family of aircraft assumed the use of weight-reducing composite materials in the wings and fuselage, and horizontal and vertical stabilizers. The materials consisted of 85-percent aluminum and 15-percent low-weight composites. Engine and nacelle acoustic treatment technology levels were as needed to limit sideline noise to 95 EPNdB at 500 feet. These characteristics are similar to designs developed by Boeing under contract to NASA (Ref. 6). A major difference between the Boeing and NASA designs, however, is that the latter uses the Allison PD287-43 two-stream engine in place of a Pratt & Whitney advanced engine concept. The NASA design requires less thrust per engine and results in a reduction in total aircraft weight for a given passenger capacity. Cruise Mach number is 0.8 at 30,000 feet.

1. DESIGN FEATURES AND PERFORMANCE CHARACTERISTICS

The NASA design studies were performed using a version of the VASCOMP II V/STOL Aircraft Sizing and Performance Computer Program (Ref. 7). Studies of sensitivities of Augmentor Wing aircraft designs to such parameters as wing aspect ratio, sweep, and thickness/chord ratio had been performed in earlier studies and were adopted with little modification. The computer effort concentrated on sizing aircraft to meet design range and cruise requirements with the Allison engines. All aircraft were sized for an 80-pound-per-square-foot wing loading and a 0.42 takeoff thrust-to-weight ratio.

*Reserves are defined as the additional fuel needed to fly 230 statute miles at 20,000 feet at cruise speed plus that needed to fly 15 minutes at 10,000 feet at 250 knots equivalent airspeed (EAS).

The VASCOMP II computer program also produced a set of mission profiles which were modified to account for the following properties of a real flight profile:

- Initial climb speed from takeoff to 10,000-foot altitude is equal to less than half the 250 knots (EAS) used.
- Maneuvering after takeoff is required to intercept the enroute airway.
- Speed on descent through 10,000 feet should be reduced to 250 knots (EAS).
- Further reduction in speed is required in the terminal area to permit intercept of final approach course and to prepare for landing.
- Some air traffic delays, occasioned by other traffic in the terminal area, are inevitable. A value of three minutes was selected, predicated on dedicated STOL airspace.

Appropriate changes to block time and block fuel were made to account for these effects and for taxiing-in/taxiing-out and takeoff/landing roll. The resulting block time and fuel consumption are shown in Table 1.

Table 1. Aircraft Block Performance

Stage Length (mi)	Cruise Altitude (ft)	Block Time (hr)	Fuel Requirements (lb)			
			Aircraft Size (No. of Passengers)			
			50	100	150	200
50	7,500	0.364	1,928	3,451	4,843	6,244
100	14,000	0.459	2,855	5,158	7,119	9,084
200	26,000	0.650	3,932	7,085	9,998	12,925
300	30,000	0.840	4,737	8,394	11,690	14,988
500	30,000	1.220	6,701	11,825	16,403	20,980

2. EXTENDED RANGE DESIGN

The basic Augmentor Wing STOL aircraft described in Figure 4 had its passenger capacity reduced to compensate for the increased fuel required to convert it to an extended range aircraft capable of serving the New York/Chicago nonstop market. The tradeoff was made on the basis of the following assumptions:

- Rate of fuel consumption during cruise is equal to that of the basic aircraft.
- One passenger and his baggage is equivalent to 220 pounds.
- Fuel system weight increases in proportion to fuel weight requirements.
- Additional fuel is carried within the volume and balance limits of the basic aircraft.
- Allowance for food service is necessary due to extended time of flight.

Table 2 lists the modified aircraft design parameters used in the extended range analysis.

Table 2. Extended Range Aircraft Parameters

No. of Passengers (Basic Aircraft)	50	100	150	200
Takeoff Gross Weight, lb	54,801	100,000	142,782	186,169
Adjusted Operating Weight Empty, lb*	34,970	62,400	87,946	114,206
Adjusted Passenger Capacity (750-mile trip)	33	72	110	148

* Additional tankage weight based on 1150-mile capability

3. NOISE CHARACTERISTICS

STOL aircraft noise curves were developed using data supplied by NASA. Specifically, Boeing data (Ref. 6) were modified to reflect the use of the Allison PD287-43 engine, instead of the Pratt & Whitney STF-395D engine used by Boeing. The source noise, in terms of perceived noise level in decibels (PNdB), was converted to effective perceived noise level (EPNdB) by adding an overflight duration correction. The effective perceived noise level was then propagated to the ground by including attenuation due to spherical divergence appropriately corrected for atmospheric attenuation. Strong tones were eliminated by the sonic inlet design. It was found that curves for equivalent engine power levels could not be distinguished from one another for flap settings from 20 to 35 degrees. Furthermore, because operation of tuned-acoustic linings was more efficient in the augmentor ducting at high flap settings, 65 degrees of flap actually produced slightly less noise than did lower flap settings. Figure 5 indicates the effect of slant range from observer to aircraft on the noise produced by a 150-passenger Augmentor Wing STOL aircraft. The curves in Figure 5 were based on information obtained from References 6 & 8. Typical departure and approach noise levels are shown. Not included in these data are either spatial effects due to focusing noise in certain directions or excess ground attenuation effects. These are, however, accounted for in noise impact computations.

4. AIR POLLUTION

The aircraft emissions considered in this study are carbon monoxide (CO), hydrocarbons (HC), and oxides of nitrogen (NO_x). Recent studies (Refs. 9, 10, 11) show that advanced state-of-the-art multistage turbofan engines incorporating high bypass ratios and advanced combustor and fuel-injection systems can be operated with only 27, 16, and 41 percent of the CO, HC, and NO_x emissions, respectively, of current technology engines at comparable thrust levels. These reductions are based on a comparison of

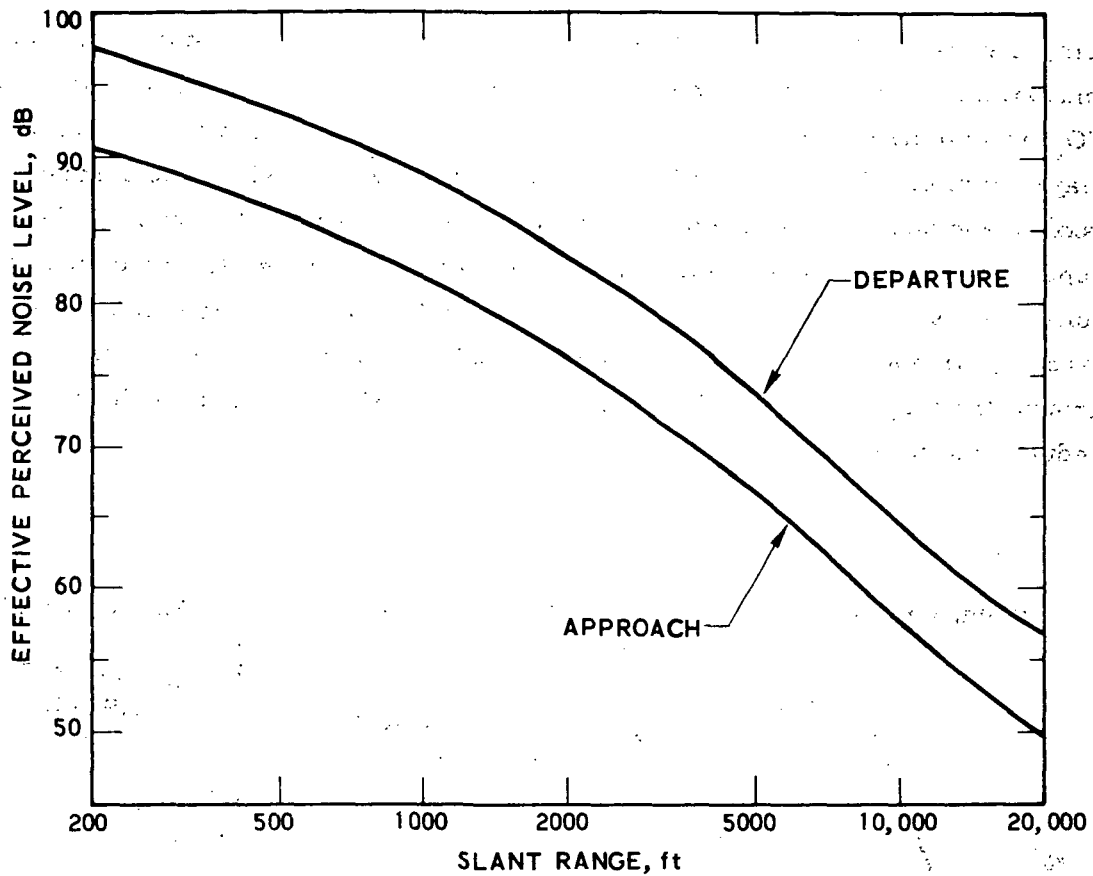

Figure 5. Noise Characteristics, 150-Passenger Augmentor Wing Aircraft

emissions from the Allison PD287-43 engine with those projected for the Pratt & Whitney JT8D-15 turbofan engine as both engines operate through identical landing/takeoff cycles (Refs. 12, 13).

The rate of formation for each pollution constituent varies throughout the landing/takeoff cycle. At the high thrust levels experienced during takeoff and climbout, combustor air inlet and exhaust temperatures are high, resulting in the formation of large amounts of NO_x . Conversely, these high

temperatures promote oxidation reactions of HC and CO, resulting in low emission levels for these two constituents. At the lower throttle settings, NO_x emissions decrease while CO and HC emissions increase. Thus, a major portion of the CO and HC emissions are created while the aircraft is taxiing and waiting for takeoff. Figure 6 indicates that a ten-minute delay in departure with engines running will substantially increase the amount of these constituents produced over the landing/takeoff cycle. Any traffic control, airport, or operational improvements capable of reducing the amount of ground time spent with engines running can therefore yield significant reductions in emissions.

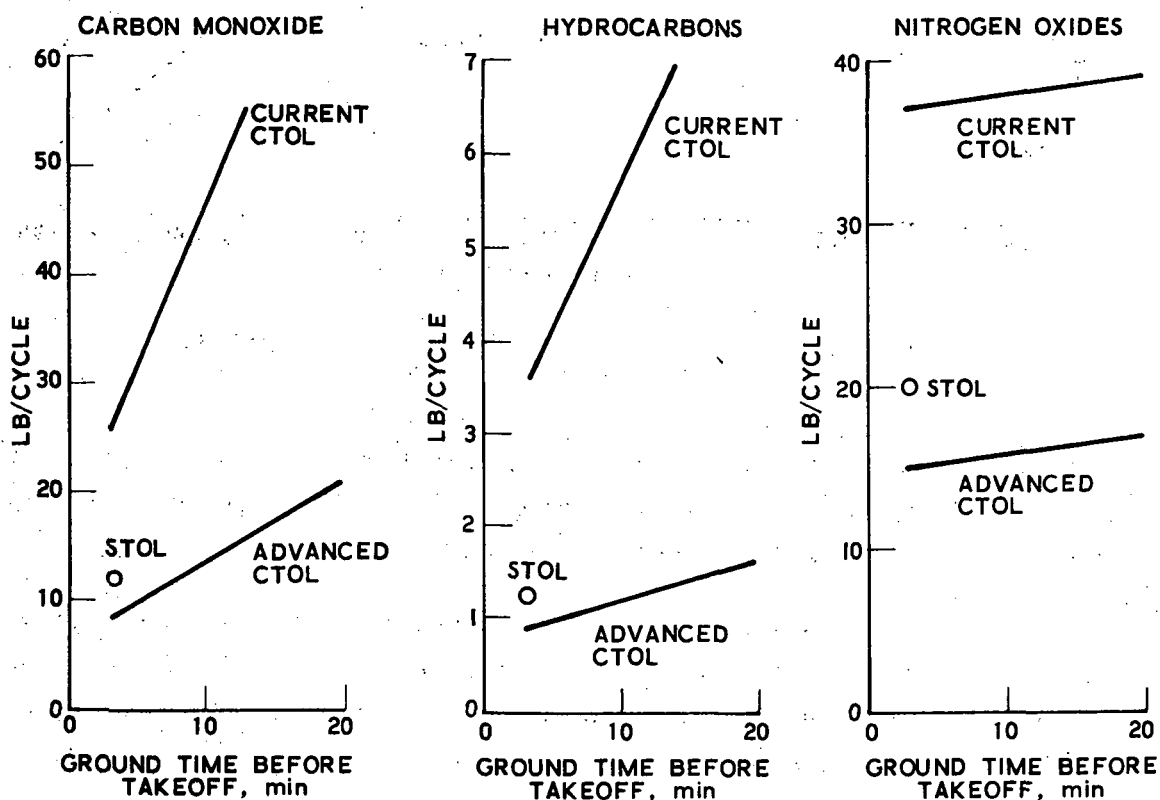

Figure 6. Comparative Emissions for 150-Passenger STOL and CTOL Aircraft

Nominal STOL takeoff ground time is 3 minutes, while that for CTOL at major domestic ports has been estimated to be as high as 19 minutes by the Environmental Protection Agency (Refs. 9 and 10).

Accounting for differences in installed thrust between STOL and CTOL, Figure 6 shows that when both incorporate advanced engine technology, the CTOL aircraft produces less emissions as long as its ground time before take-off does not exceed that of STOL aircraft by more than five to six minutes.

B. STOLPORT REQUIREMENTS

Total airport terminal area requirements are determined by the size and configuration of aircraft used and the annual number of passengers expected. In this study, land, facilities, and improvements explicitly required to support commercial STOL service are charged against the STOL system.

1. AIRFIELD

Required runway and taxiway lengths of 2000 feet were defined by the design parameters of the Augmentor Wing STOL aircraft. Runway width was taken as 100 feet (Ref. 14) and taxiway width as 60 feet (Ref. 15). Pavement thicknesses are taken from Ref. 16, assuming aircraft with a dual-tandem landing gear arrangement. All airfield requirements were computed on the basis of flexible pavements (e.g., asphalt). For a STOLport located at an existing airport, the existing pavement thickness was subtracted from the required thickness to establish the increase needed.

2. TERMINAL

The required terminal size was found by modifying FAA guidelines for terminal area floor space (Ref. 17) to account for differences between long

and short haul operating systems. The floor space elements considered included areas for passenger service, airline operations, baggage claims, passenger waiting, dining, and other concessions. Results showed that a linear fit of total area as a function of peak-hour passengers was possible, resulting in required STOLport terminal floor space of 80 square feet per peak-hour passenger.

In addition to floor space requirements, the gate-position area adjacent to the terminal building was also derived on the basis of peak-hour operations, using apron areas obtained from Ref. 18. The number of gates required at each port was derived based on the aircraft turnaround time and size plus the number of peak-hour passengers accommodated. Aircraft turnaround times assumed a single door for enplaning and deplaning passengers.

3. NOISE BUFFER ZONES

The objective of creating noise buffer zones is to indemnify property owners in the vicinity of STOLports from adverse effects of noise generated by STOL aircraft. In addition to the purchase of land parcels at fair market value, the acquisition of a noise buffer zone includes the costs of an environmental impact study, housing cost differentials, moving expenses, a relocation assistance office, small business interruption, and appraisal and acquisition management.

Determining the size of a noise buffer zone required at a STOLport depends on three items:

- Noise contours produced by aircraft operations at the port.
- Existing boundaries of the port.
- Land uses in areas surrounding the port's existing boundaries.

In this study, the complete cost of creating STOL-induced noise buffer zones, without any benefits being assumed for resale or converted use of the property, was charged to the STOL system. This was done to ensure a conservative

estimate of economic viability of the STOL system. As a practical matter, however, the noise level predicted for the Augmentor Wing aircraft was so low that noise buffer zone costs did not significantly affect system economics.

The impact of noise on the community immediately adjacent to an airport boundary was studied with the aid of a figure of merit called the Noise Exposure Forecast (NEF). It was developed (Ref. 19) to combine single-event aircraft flyby noise effects on observers with the growing annoyance they feel as the number of flyby events increases. The noise analysis performed in this study was directed at determining the extent of adverse aircraft noise impact on land adjacent to selected STOLports. Noise exposure forecasts of 30, 35, and 40 were utilized to judge noise acceptability in residential, commercial, and manufacturing land use zones, respectively. An adverse noise impact was said to exist when a parcel of land, or a portion thereof, was contained within an unacceptably high NEF contour.

C. ECONOMICS

The economic methodology determined the costs of flight and ground equipment, airline operations, STOLport facilities, and noise buffer zones.

1. AIRCRAFT INVESTMENT

Flyaway cost was based on development of production quantities of STOL aircraft as a function of capacity in the manner described in an earlier study of V/STOL aircraft implementation (Ref. 20). These production quantities were utilized to introduce a variation in development costs with changes in aircraft size. Engine production quantities were assumed on the basis of five engines per airframe. Airframe development costs were estimated by studying the costs to develop CTOL airframes. Airframe manufacturing costs were also based on analyses of CTOL airframe manufacturing costs as functions of production quantities, design range, weight, and other factors.

Unit airframe manufacturing costs were combined with the amortized airframe development costs to find total airframe unit costs. Engine development and manufacturing costs were combined in data provided by the Allison Division of General Motors Corporation (Ref. 21). The combined engine development and manufacturing unit costs were obtained by extracting Allison engine unit cost data for the appropriate thrust level and production quantity. Table 3 indicates the production quantities assumed and the various costs determined.

In addition to flight equipment investment costs, allowances were added for ground facilities and equipment. Flight equipment investment is defined as aircraft flyaway cost plus spares, multiplied by fleet size. Spares constitute 10 percent of the airframe value and 30 percent of the engine value. Total investment is the sum of flight equipment, ground facility, and ground equipment costs, where the costs of the latter two are determined by taking a constant percentage of the value of the flight equipment.

Table 3. STOL Aircraft Production Base and Unit Costs

Aircraft Capacity, Passengers	Planned Production Base, (No. Aircraft)	Airframe Development Cost (\$ millions)	Unit Costs (\$ thousands)		
			Airframe	Engines (4)	Flyaway
50	980	200	2647	1112	3759
100	490	300	4586	1748	6334
150	330	400	6635	2124	8759
200	240	500	8792	2424	11216

2. OPERATING COSTS

Direct operating costs (DOCs) relate to flight equipment (including spare parts) depreciation, hull insurance, flight crew, fuel, oil, and maintenance (including maintenance burden). Excluded are aircraft-related variable costs such as landing fees and cabin crew costs. This is the general industry definition of DOCs and was the definition used for this study.

The Boeing 1971 DOC formula (Ref. 22) was used with modifications to reflect STOL operations. Items modified for this study were fuel cost, hull insurance, maintenance, flight crew size, airframe spares, depreciation, and utilization. Descriptions of specific modifications are contained in Volume II, Appendix A (Ref. 3).

All operating costs not classified as DOCs are included in indirect operating costs (IOCs). Interest expense is classified as a nonoperating cost and is considered a part of return on investment (ROI).

IOC models based entirely on CTOL cost experience necessarily reflect average system IOC levels, in which effects of operating from a mix of airports, (with varying levels of user charges reflecting the costs of existing terminals and airfields) are aggregated into a composite IOC level for the airline. For a STOL system to be operated from entirely new ports or improved general aviation ports, basing all IOC coefficients on historical CTOL experience would be a serious deficiency. In this study, all IOC elements which are determined by port user charges and port-peculiar operating costs were modeled explicitly and combined as Δ IOC. That is, STOLport terminals and airfields are costed directly, and the amortized capital costs and operating expenses are allocated to the STOL system. The Δ IOC term is the basis for ensuring that the STOL system generates sufficient revenue to finance essential STOLport facilities.

In total, the Δ IOC term covers the following port and port-related items:

- STOL airfield capital construction and operating costs.
- STOL terminal capital construction and operating costs.*
- Noise buffer zone acquisition costs.
- Port or airline station operating costs for the functions of passenger, baggage, and aircraft handling.
- Maintenance and depreciation costs of airline ground property and equipment.

Non-port-related IOC elements (including passenger service, reservations and ticket sales, advertising, and general and administrative expense) were derived and allocated in two separate IOC models. For the intrastate California Corridor arena, the experience of Pacific Southwest Airlines (PSA) was used. For the interstate Northeast Corridor and Midwest Triangle arenas, U. S. domestic trunk airline experience was used. The variation of direct and indirect operating costs with respect to block distance and vehicle size is illustrated in Figure 7.

3. RETURN ON INVESTMENT

Return on investment is used as a comparative measure of economic viability. It is an appropriate measure for a system at a single time period and does not require time-discounting of future returns and costs. A positive ROI is required to provide for the cost of capital and thus ensure the viability of a commercial enterprise.

The CAB formula for ROI includes interest payments in the same context as profit. The size of the interest payment is dependent on both the debt-to-equity ratio of the airline and the interest rate. For the specific values of these parameters used in this study, the CAB 8-percent ROI is

* Typical concessions, such as restaurants or parking lots, were assumed to be self-supporting.

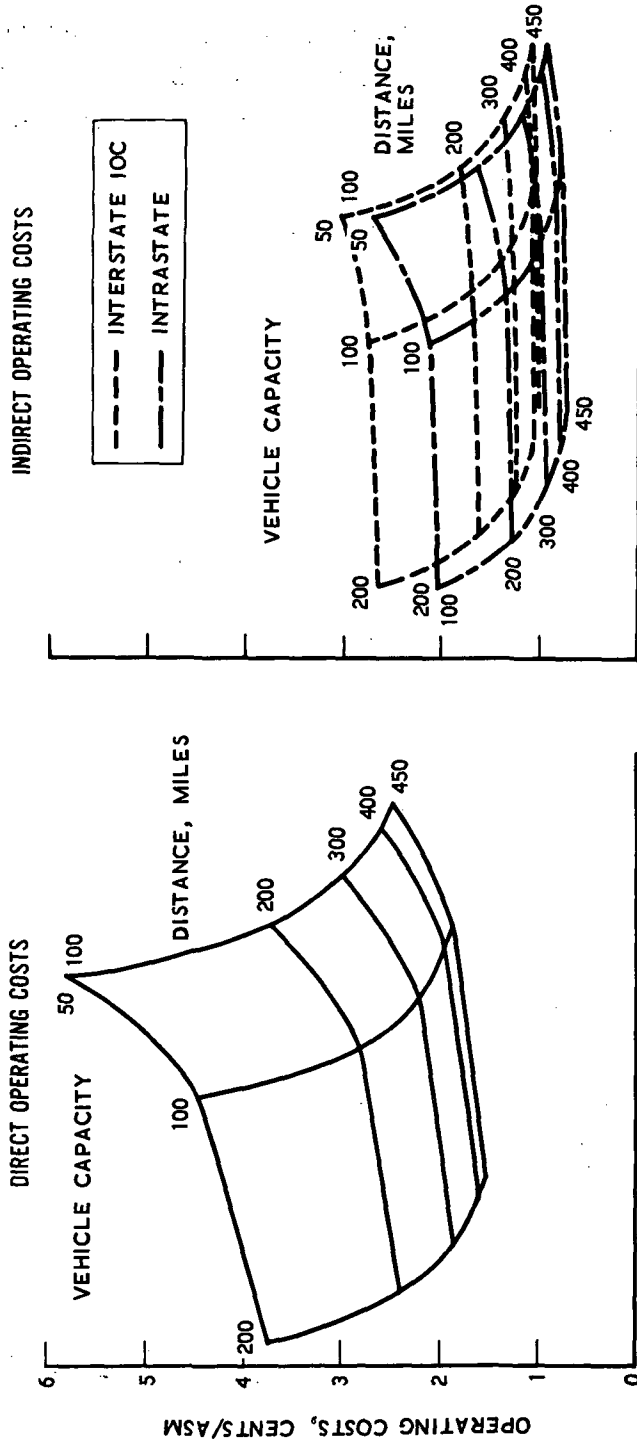

Figure 7. Variation of Direct and Indirect Operating Costs

equivalent to an 11-percent return on stockholder equity. The latter approximates the current average return on stockholder equity (10.4 percent) experienced in the U. S. economy during 1969/71 (Ref. 23). The CAB 8-percent ROI was chosen as the criterion for economic viability of the selected systems considered in this study.

Page Intentionally Left Blank

V. ARENA DESCRIPTIONS

The characteristics of an arena can be categorized into three groups. The first includes the geographic, demographic, and socioeconomic factors of each region* within the arena. The second identifies the total intercity travel demand. The last portrays the projected transportation systems.

One point of clarification should be noted. It is customary to refer to the travel characteristics between two regions as "city pair" characteristics. In this context, the word "city" is not the city itself as defined by the city limits, but actually includes the suburban areas and contiguous cities in the region surrounding the city as well. All references to "city pairs" should thus be interpreted as being regional pairs, e.g., (greater) New York City-(greater) Boston areas.

A. REGION DESCRIPTIONS

Figures 8, 9, and 10 show the regions defined in the study: Los Angeles, Sacramento, San Diego, and San Francisco in the California Corridor; Chicago, Cleveland, and Detroit in the Midwest Triangle; and Boston, New York, Philadelphia, and Washington in the Northeast Corridor. The regional boundaries, which were defined by the cognizant regional planning agency, included all existing major transportation ports in addition to large population and employment centers. These same agencies also provided the bulk of the population and income data on a zonal basis. A summary of regional socioeconomic characteristics and data sources is presented in Table 4.

*Throughout this study, each region carries the name of its major city and the terms city and region are synonymous.

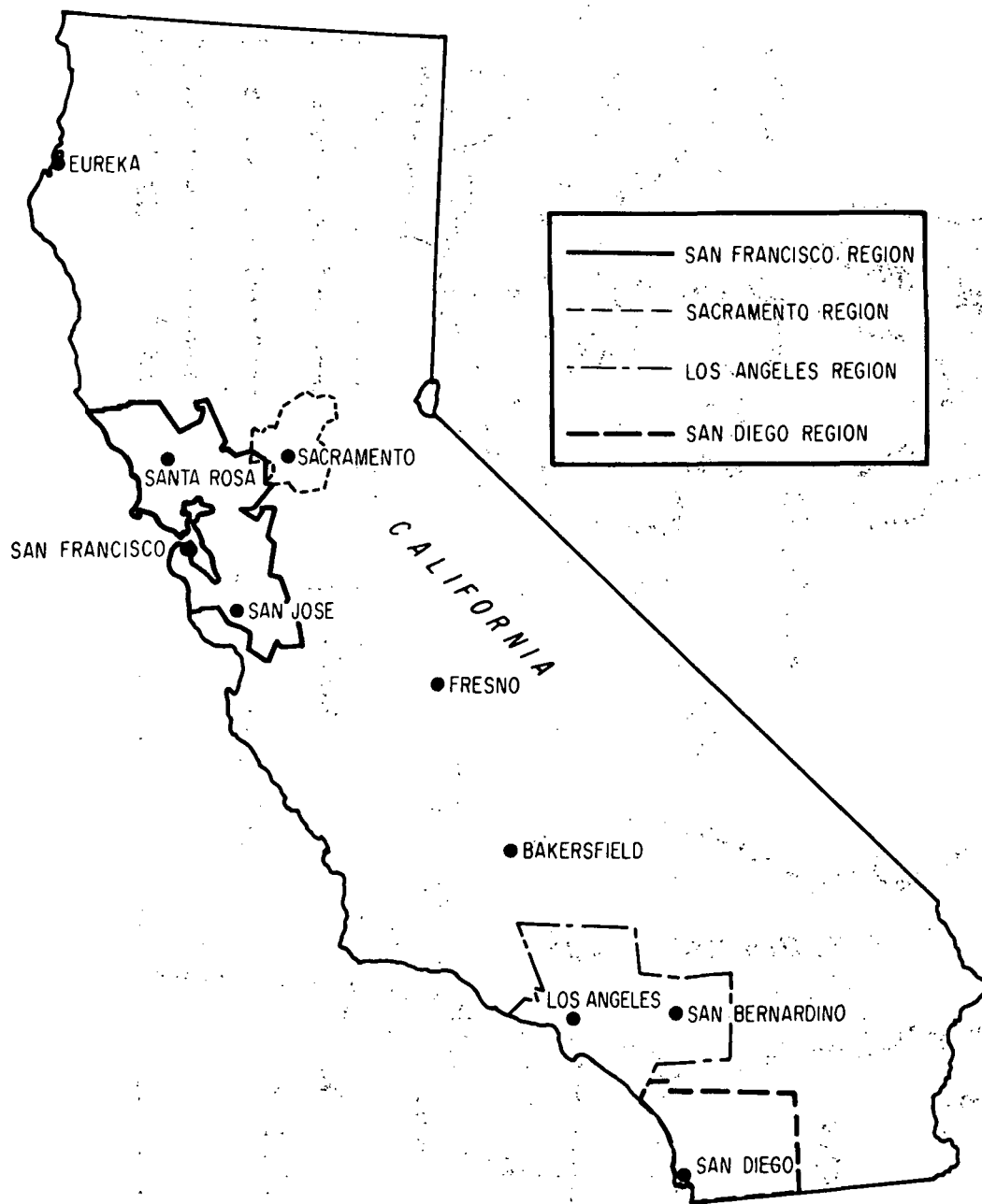

Figure 8. California Corridor

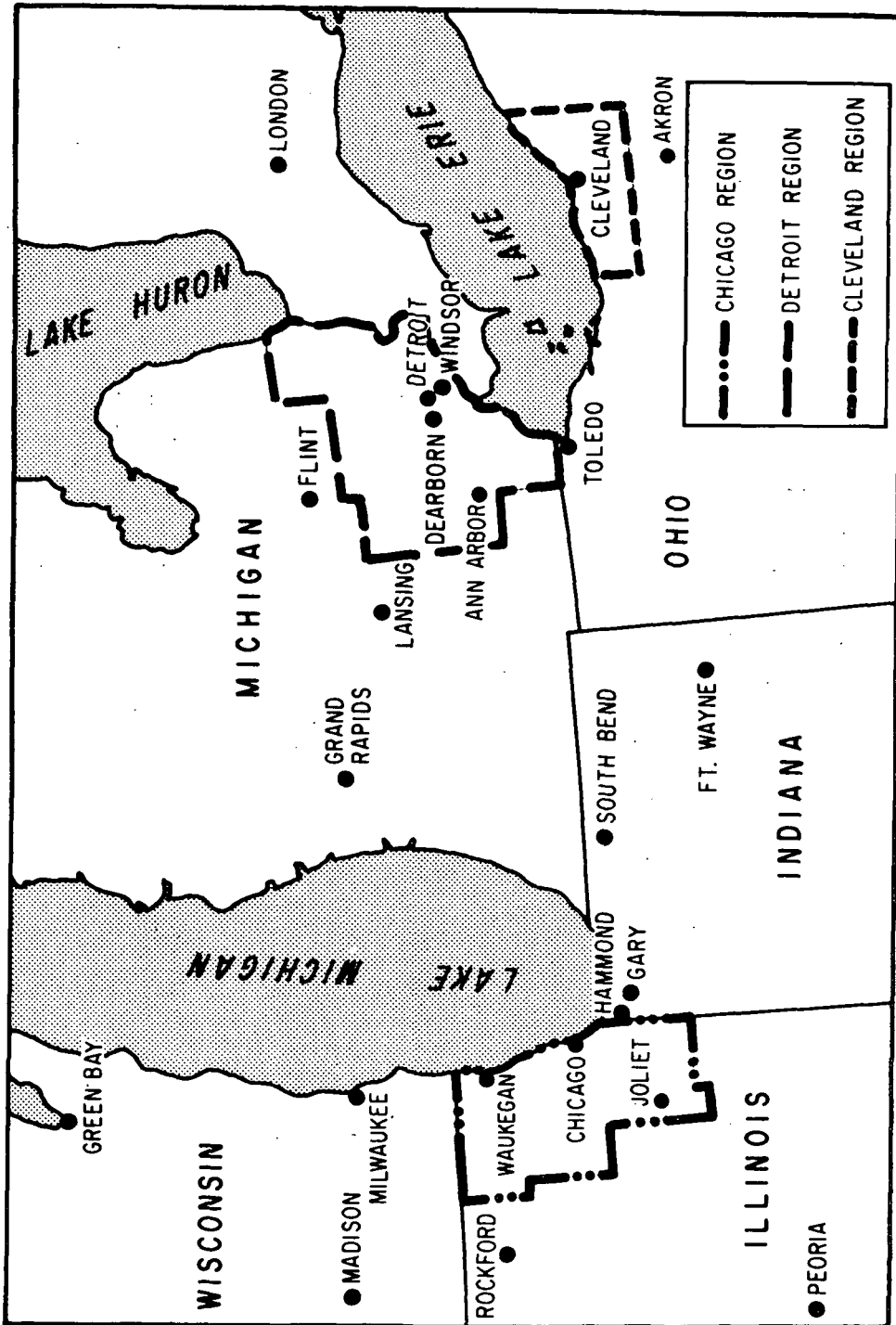

Figure 9. Midwest Triangle

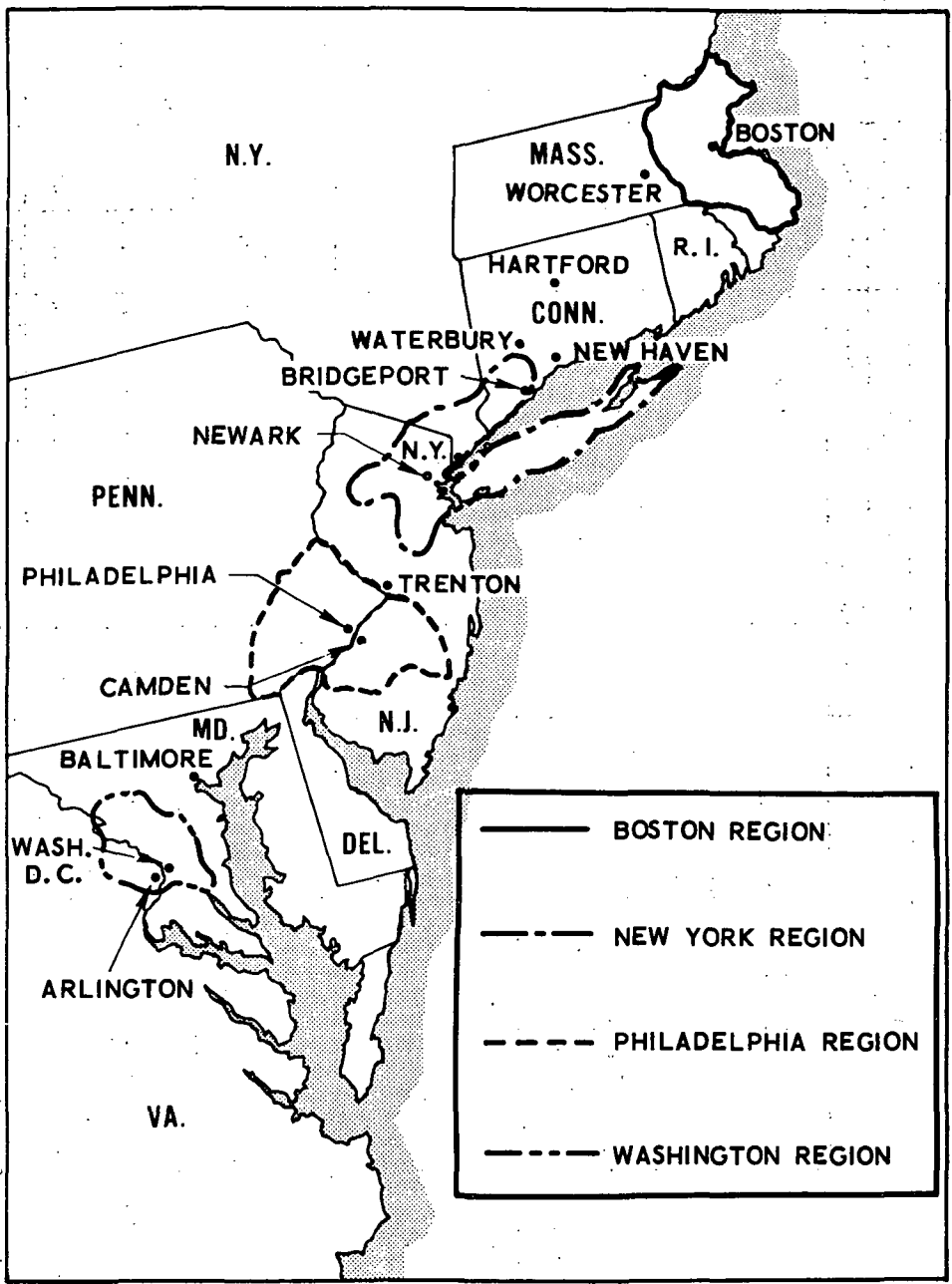

Figure 10. Northeast Corridor

Table 4. Regional Data Sources and Socioeconomic Characteristics

Corridor	Region	Regional Organization Data Source	Zone Nomenclature	Number of Zones	Stylized Area (mi ²)	Population		Median Income		Hotel/Motel Units Modeled
						1967	1980	1967	1980	
California	Los Angeles	Los Angeles Regional Transportation Study (LARTS)	LARTS Statistical Areas	75	6160	9,193,254	11,183,489	7756	9658	32,473
	Sacramento	Sacramento Area Transportation Study (SATS)	Regional Analysis Districts (RADs)	31	1960	756,103	1,015,503	7870	13857	3,687
	San Diego	San Diego Metropolitan Area Transportation Study (SDMATs)	Subregional Areas	37	2660	1,200,295	1,755,260	7608	16321	24,370
	San Francisco	Bay Area Transportation Study Commission (BAISC)	Districts	98	6520	4,250,367	5,322,169	9224	12146	26,486
	Totals:				17,300	15,400,019	19,276,421	8155	11173	87,016
Midwest	Chicago	Chicago Area Transportation Study (CATS)	Range-Township Areas	123	3450	6,878,671	8,705,530	10809	18586	111,002
	Cleveland	Northeast Ohio Area-wide Coordinating Agency (NOACA)	Planning Districts	63	1380	2,184,057	2,552,525	9469	14745	9,873
	Detroit	Detroit Regional Transportation and Land Use Study (TALUS)	Analysis Superdistricts	53	3790	4,536,205	5,779,050	8964	14692	15,891
Totals:					8620	13,598,933	17,037,105	9978	16681	136,766
Northeast	Boston	Boston Transportation Planning Review (BTPR)	BTPR Districts	89	2513	1968	3,804,250	1968	15413	11,203
	New York	Tri-State Regional Planning Commission	Data Aggregation Districts & Zones (DADZ)	152	3138	17,180,400	20,049,100	8987	13065	59,011
	Philadelphia	Delaware Valley Regional Planning Commission (DVRPC)	Data Collection Districts (DCD's)	192	3521	4,310,206	4,700,000	8152	11414	13,424
	Wash., D.C.	Metropolitan Washington Council of Governments	Policy Analysis Districts	140	1021	2,570,300	3,857,300	10901	18039	32,901
Totals:					10,793	27,865,156	32,813,300	9122	13714	116,054

B. INTERCITY TRAVEL DEMAND

Travel demand data were required for two basic purposes. The first was to calibrate the Aerospace modal split program, which required complete data on daily travel by all competing modes between each city pair for a specific calibration year. The second was to complete the data base needed to project the total travel for a future year.

The base year modal demand and total demand, and the projected 1980 total demand are shown in Table 5 for the California Corridor and Midwest Triangle city pairs. Similar data for the Northeast Corridor, using the DOT Northeast Corridor Transportation Project (NECTP) (Ref. 5) are shown in Table 6. Since the latter source provided trips disaggregated by business/nonbusiness trip purposes, this was used in the modal split calibration process for further refining preference-factor estimates.

C. INTERCITY TRANSPORTATION CHARACTERISTICS

The projected 1980 characteristics of existing transportation modes are substantially unaltered from their current values. All fares are expressed in 1970 dollars. This assumption is equivalent to assuming that the fare increases up to the 1980 time period would be equal to those due to inflation. Similarly, it was assumed the transportation equipment for non-STOL modes would not change significantly during this period, so that travel times would not change. One exception to this was the rail mode for the Northeast Corridor wherein the characteristics reflect the Interim High-Speed Rail System-Option 1 recommended by the Department of Transportation (Ref. 5).

Alternative modes considered for the 1980 time period were car, CTOL, bus, and rail. For certain city pairs, there was neither a current rail service nor any indications that service would be instituted in the near future. Typical intercity mode characteristics are shown in Table 7. Common carrier costs and times are based on major port-to-major port operations. Speeds and costs per mile were calculated using air mile distances;

Table 5. California Corridor and Midwest Triangle Demand Data Summary

Arena	City Pair	Population Product (X 10 ⁹)		Average Daily Demand															
		1967	1980	1967				1980				1980							
		Trips	% M. S.	Trips	% M. S.	Auto	Air	Bus	Rail	Total	Trips	% M. S.	Trips	% M. S.	Total	Trips	% M. S.	Trips	% M. S.
California Corridor	Los Angeles/ San Francisco	38316	56697	7466	55.11	5725	42.26	252	1.86	104	0.77	13547	100.00	18890	100.00				
	Los Angeles/ Sacramento	5640	7714	1349	63.36	700	32.88	59	2.77	21	0.99	2129	100.00	3427	100.00				
	Los Angeles/ San Diego	11551	18398	25230	90.19	1067	3.81	1498	5.35	182	0.65	27977	100.00	38235	100.00				
	San Francisco/ San Diego	5117	8178	813	54.36	643	43.01	39	2.63	-	-	1495	100.00	3204	100.00				
	San Francisco/ Sacramento	2499	3429	13800	95.48	101	0.70	552	3.82	-	-	14453	100.00	18852	100.00				
	San Diego/ Sacramento	753	1113	108	66.87	47	29.05	7	4.08	-	-	162	100.00	547	100.00				
Midwest Triangle	Chicago/ Cleveland	13,700	16,600	860	61.42	467	33.36	55	3.93	18	1.29	1400	100.00	2000	100.00				
	Chicago/ Detroit	27,500	35,000	1982	69.54	652	22.88	172	6.04	44	1.54	2850	100.00	4050	100.00				
	Cleveland/ Detroit	8,230	9,700	1375	78.13	272	15.45	113	6.42	None	--	1760	100.00	2300	100.00				

M. S. = Modal Split Trips = Person trips in each direction

Table 6. Northeast Corridor Demand Data Summary

City Pair	Population Product (X 10 ⁹)		Trip Purpose (1)	% of Total Trips	Average Daily Demand												
	1968	1980			1968				1980				1980				
					Auto		Air		Bus		Rail		Total (1)		1980		
Trips	% M. S.	Trips	% M. S.	Trips	% M. S.	Trips	% M. S.	Trips	% M. S.	Trips	% M. S.	Trips	% M. S.	Trips	% M. S.		
Boston/ New York	65359	84345	Business	36.05	1229	39.78	1710	55.35	64	2.09	86	2.79	3090	100			
			Non-Business	63.95	3816	69.60	894	16.31	535	9.76	237	4.33	5483	100			
			Total		5064	58.73	2617	30.34	608	7.05	334	3.87	8623	100	11,119		
Boston/ Philadelphia	17880	23138	Business		560	51.63	464	42.72	42	3.88	19	1.77	1085	100	1,767		
			Non-Business														
Boston/ Washington	9778	16227	Business	42.63	51	11.62	384	87.12	1	0.33	4	0.93	440	100			
			Non-Business	57.37	197	33.24	344	58.09	35	5.85	17	2.82	593	100			
			Total		249	24.04	728	70.39	37	3.55	21	2.02	1035	100	2,562		
New York/ Philadelphia	80748	110270	Business														
			Non-Business														
			Total		14658	78.27	88	0.47	589	3.15	3392	18.11	18727	100	23,840		
New York/ Washington	44159	77335	Business	36.97	111	33.51	1735	52.35	120	3.63	348	10.51	3315	100			
			Non-Business	63.03	3507	62.05	816	14.44	816	14.44	512	9.07	5651	100			
			Total		4626	51.20	2585	28.39	949	10.50	894	9.90	9034	100	15,282		
Philadelphia/ Washington	12080	21215	Business	34.76	1302	71.27	253	13.83	32	1.76	240	13.14	1827	100			
			Non-Business	65.24	2871	83.69	61	1.78	193	5.62	306	8.91	3430	100			
			Total		4179	78.74	314	5.91	245	4.63	569	10.72	5308	100	9,859		

(1) "Totals" include trips where trip purpose was not stated and are thus slightly larger than the sum of the business and nonbusiness trips

M. S. = Modal Split Trips = Person trips in each direction

Table 7. 1980 Mode Characteristics

Arena	City Pair	Intercity Distance (air miles)	Mode	Mode Characteristics				
				Time (hr)	Cost (\$)	Freq. (dep. per hour)	Cost ⁽¹⁾ per mile (¢/mi)	Speed ⁽¹⁾ (mph)
California Corridor	Los Angeles/ San Francisco	355	CAR	6.26	13.80	-	3.9	57
			CTOL	1.0	16.50	2.43	4.6	355
			BUS	9.0	13.50	1.35	3.8	39
			RAIL	10.67	16.00	0.07	4.5	33
	Los Angeles/ Sacramento	380	CAR	6.2	14.24	-	3.7	61
			CTOL	1.0	18.00	1.07	4.7	380
			BUS	9.58	12.50	0.77	3.3	40
	Los Angeles/ San Diego	101	CAR	1.4	3.52	-	3.5	72
			CTOL	0.5	8.29	1.8	8.2	202
			BUS	2.5	4.36	1.38	4.3	40
	San Diego/ San Francisco	456	CAR	2.75	4.75	0.20	4.7	37
			CTOL	8.68	19.68	-	4.3	53
			BUS	1.29	24.50	0.61	5.4	353
	San Diego/ Sacramento	481	BUS	13.0	17.40	0.69	3.8	35
			CAR	8.62	20.12	-	4.2	56
			CTOL	1.67	25.00	0.133	5.2	288
	San Francisco/ Sacramento	79	BUS	13.0	16.80	0.467	3.5	37
			CAR	1.07	2.30	-	2.9	74
CTOL			0.55	8.00	0.428	10.1	144	
Midwest Triangle	Chicago/ Detroit	238	BUS	2.2	3.84	1.78	4.9	36
			CAR	3.77	9.56	-	4.0	63
			CTOL	0.917	27.00	1.17	11.0	260
			BUS	5.55	12.70	0.64	5.3	43
	Chicago/ Cleveland	312	RAIL	5.50	16.25	0.143	6.4	43
			CAR	4.67	17.00	-	5.4	67
			CTOL	1.11	33.00	0.894	10.6	281
			BUS	7.5	15.55	0.785	5.0	42
	Cleveland/ Detroit	94	RAIL	6.6	19.75	0.072	6.3	47
			CAR	1.76	5.48	-	5.8	53
			CTOL	0.58	18.00	0.822	19.1	162
			BUS	3.15	8.25	0.715	8.8	30
Northeast Corridor	New York/ Washington	215	CAR	3.21	10.17	-	4.7	67
			CTOL	1.02	24.10	2.34	11.2	211
			BUS	4.05	10.95	2.62	5.1	53
			RAIL	2.35	15.95	2.10	7.4	91
	New York/ Boston	191	CAR	3.26	8.22	-	4.3	59
			CTOL	0.83	22.25	2.20	11.6	230
			BUS	4.5	9.25	2.84	4.8	42
	Boston/ Washington	406	RAIL	2.95	15.95	1.35	8.4	65
			CAR	8.47	23.79	-	5.9	48
			CTOL	1.28	35.23	1.78	8.7	317
	Washington/ Philadelphia	133	BUS	9.5	20.90	1.08	5.1	43
			RAIL	5.4	30.20	1.35	7.4	75
			CAR	1.79	5.80	-	4.4	74
	Philadelphia/ Boston	274	CTOL	0.67	19.47	1.14	14.6	199
			BUS	3.3	6.40	2.0	4.8	40
			RAIL	1.48	10.20	1.55	7.7	90
			CAR	6.0	15.79	-	5.8	46
				CTOL	1.0	28.74	1.71	10.5
BUS				7.5	14.37	1.0	5.2	37
RAIL				4.0	21.92	0.92	8.0	68

(1) Based on air miles

they thus tend to be low and high, respectively, for the nonair modes. Costs and times listed for car are intercity values between ports simulated at the periphery of a region and are, therefore, lower than would be the case for city center-to-city center values. In the modal split program, these differences are accounted for by using city-peculiar local travel functions. The per-mile car costs and speeds in the table were also estimated using nominal intercity air mile distances. Car costs also include tolls where applicable.

In addition to the intercity data listed, modal port characteristics were defined for each region. These included location, processing time, and cost predicated on a "curbside delivery," and the increments of time and cost (function of trip duration) associated with the drive-and-park form of local transportation. The port locations for all modes, including candidate STOL ports, are shown on the maps for each region (Figures 11 through 21). County and state boundaries, major cities and towns, and central business district (CBD) locations are also indicated.

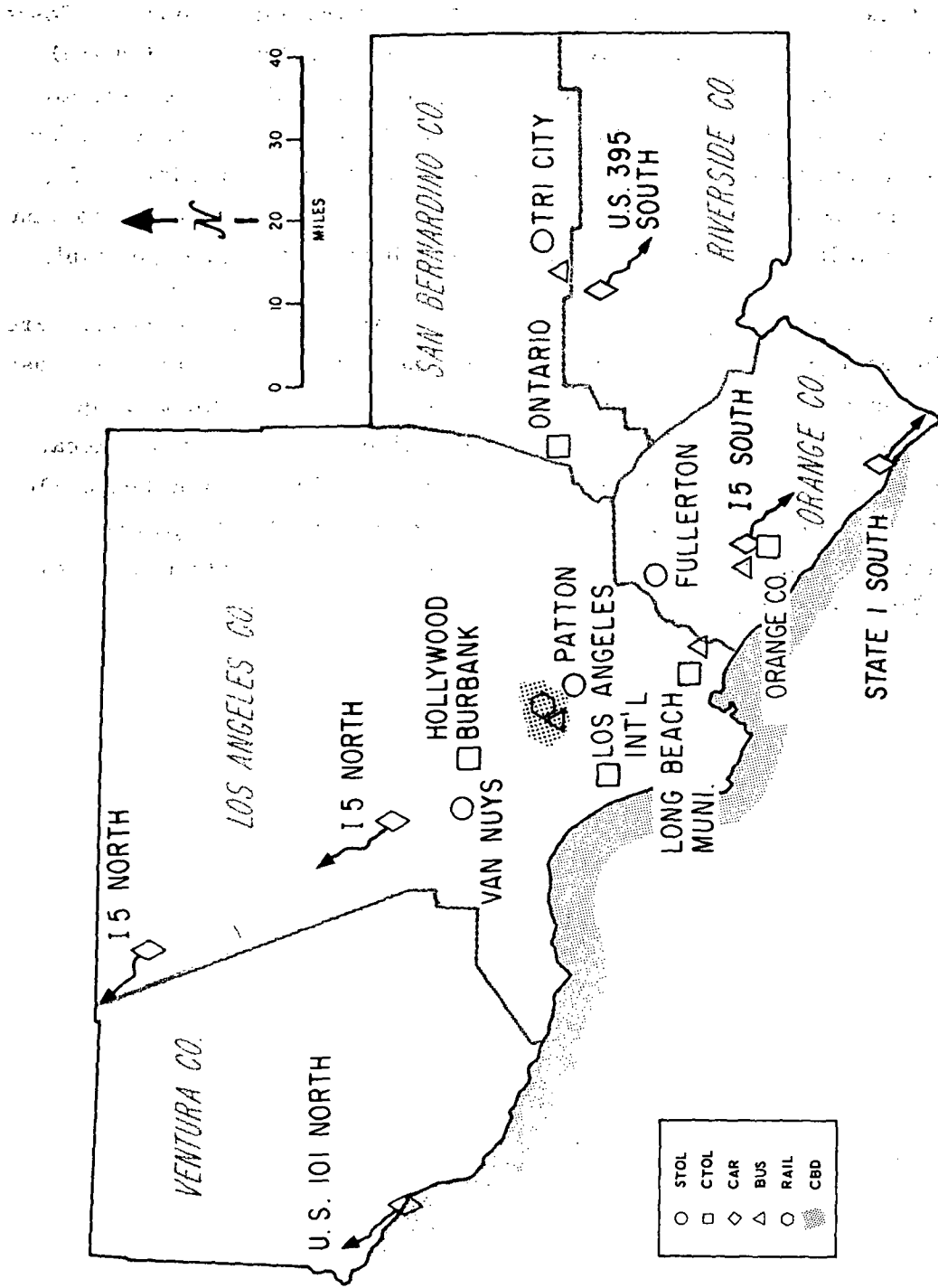

Figure 11. Los Angeles Region Port Locations

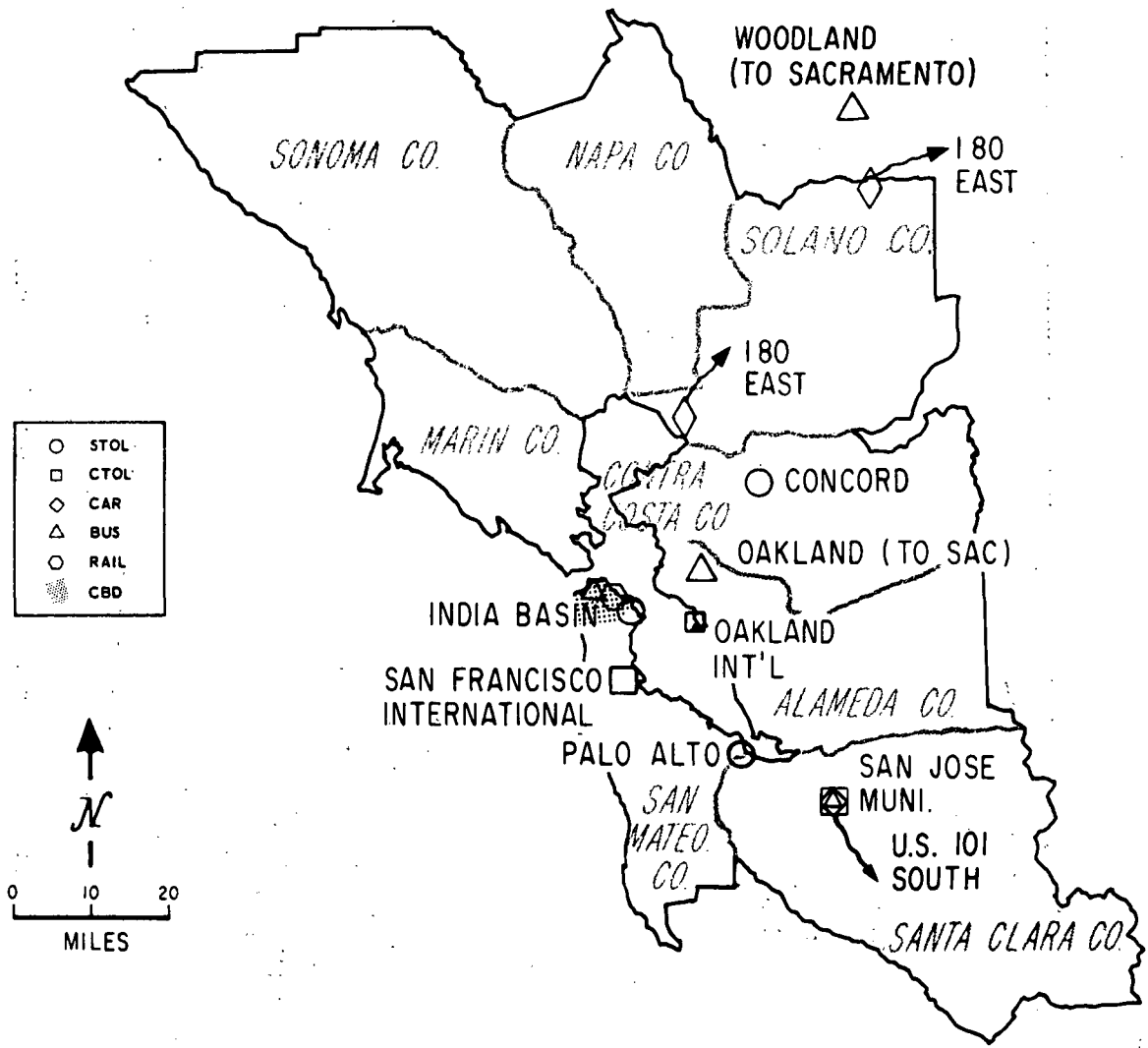

Figure 12. San Francisco Region Port Locations

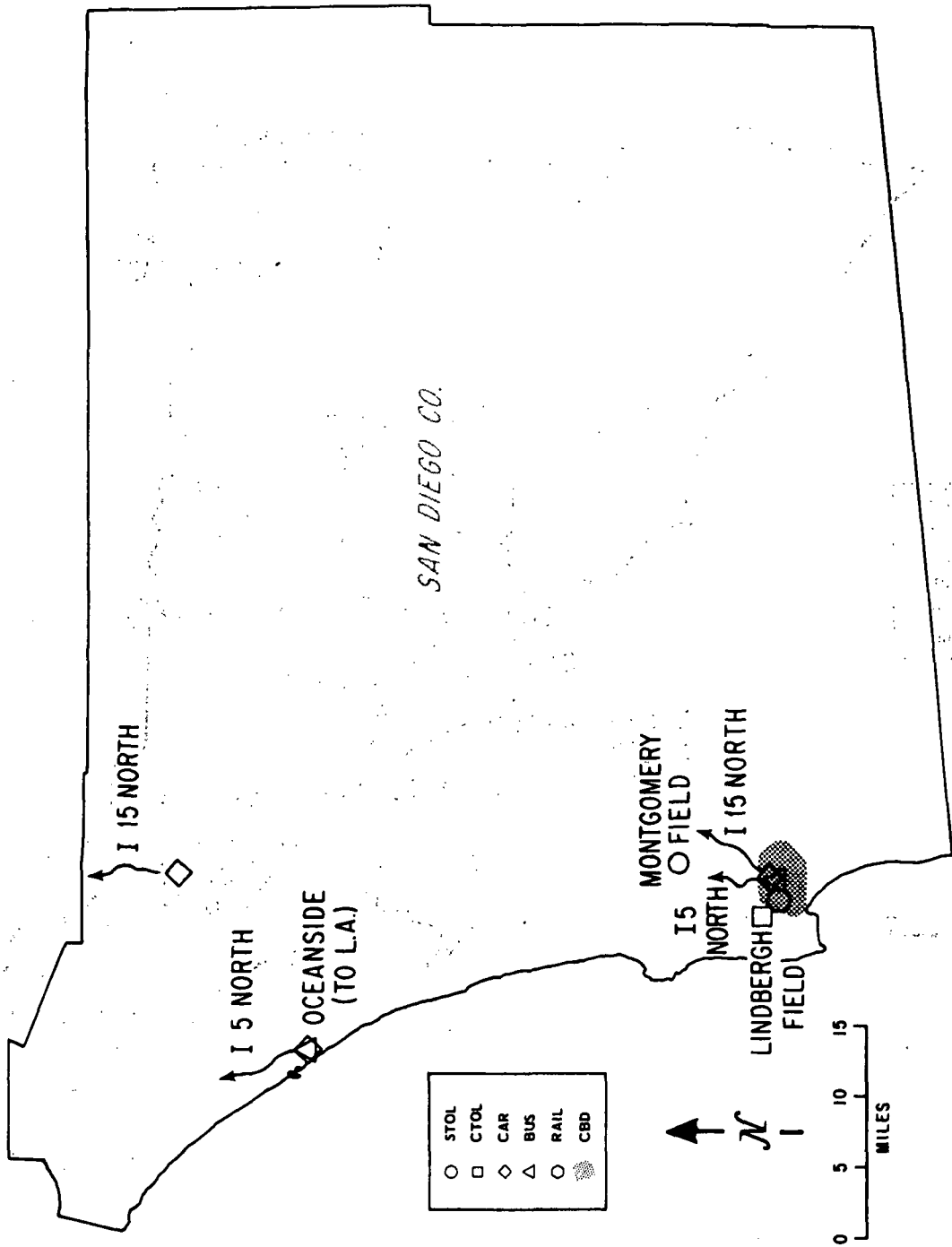

Figure 13. San Diego Region Port Locations

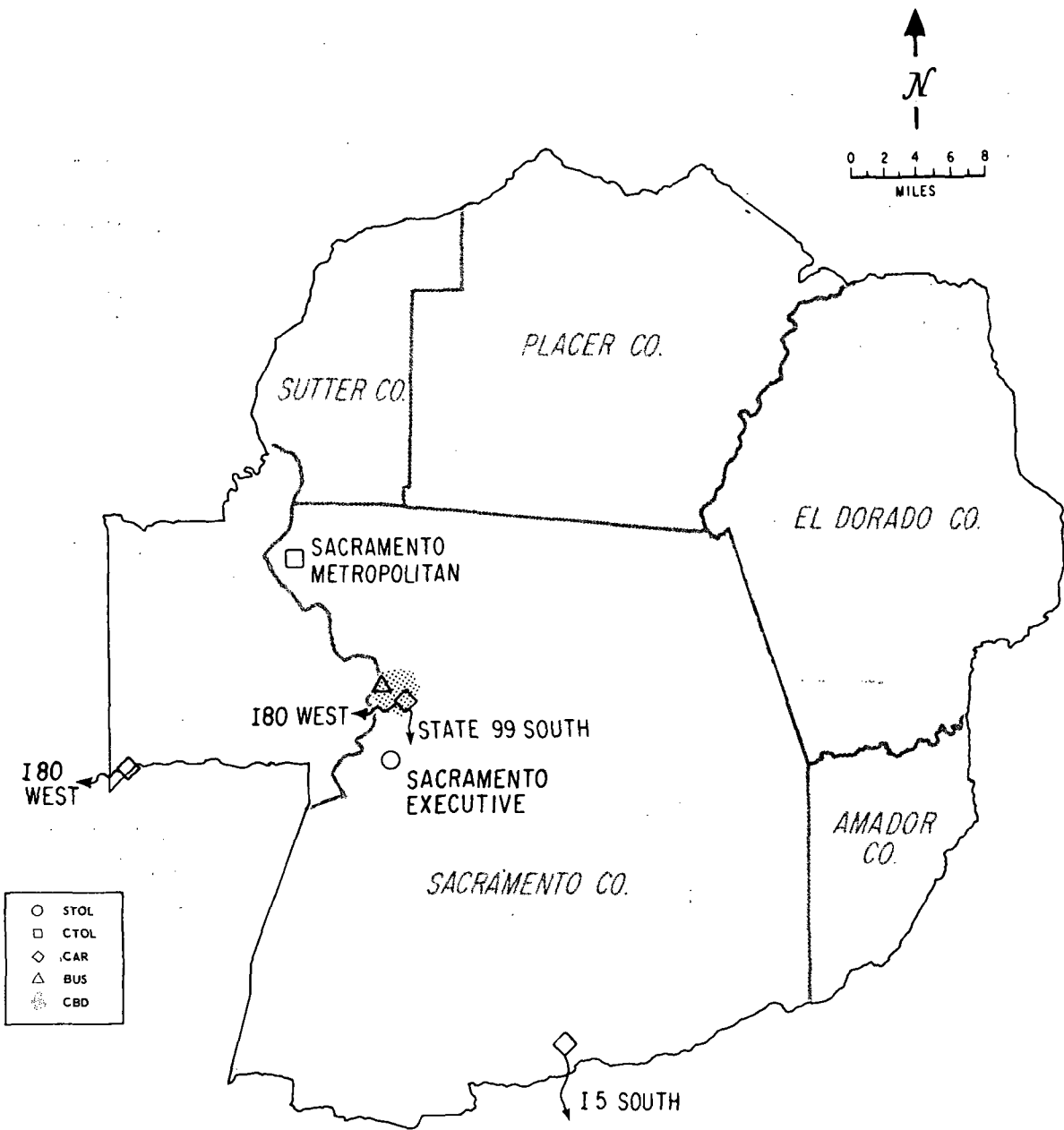

Figure 14. Sacramento Region Port Locations

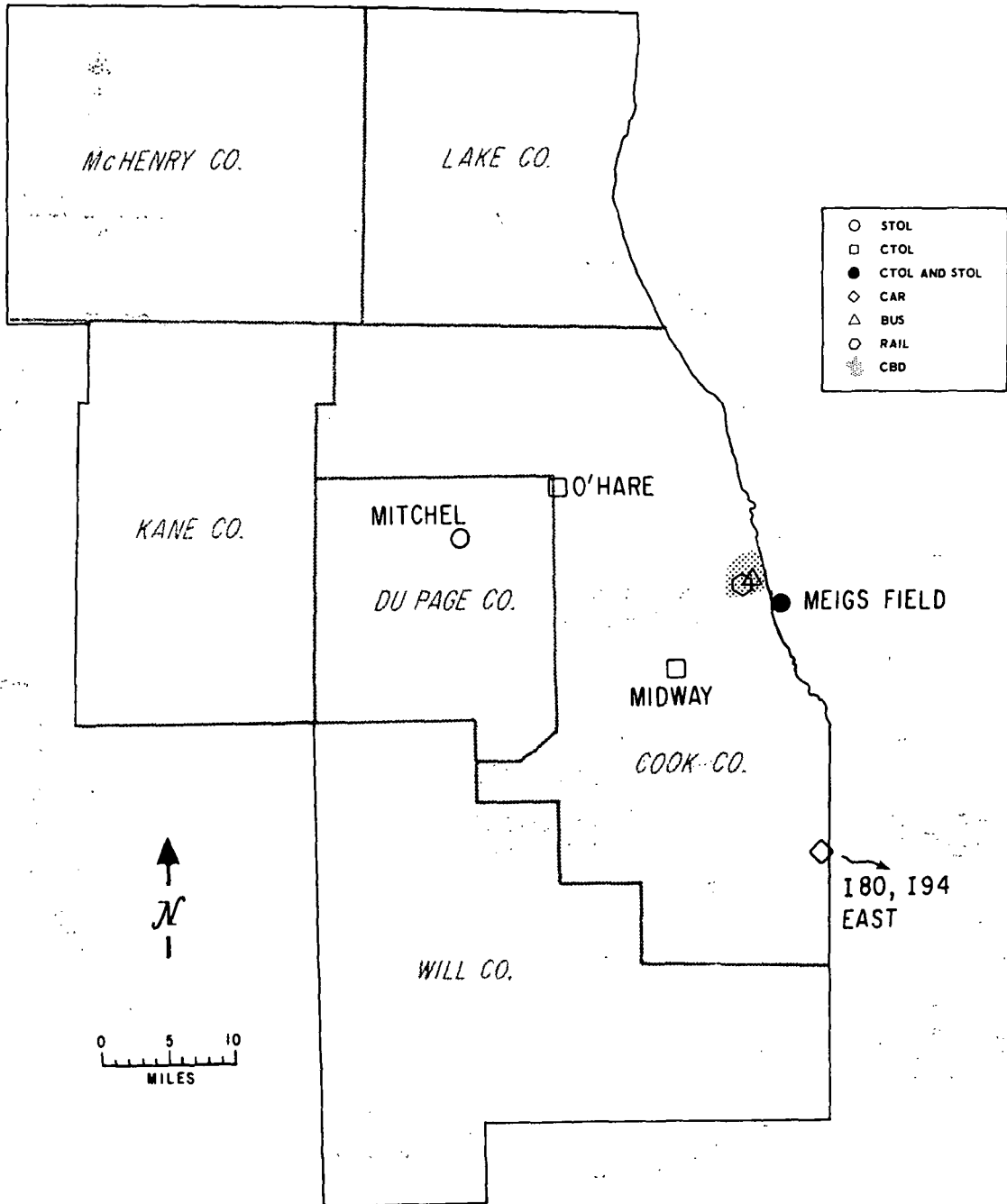

Figure 15. Chicago Region Port Locations

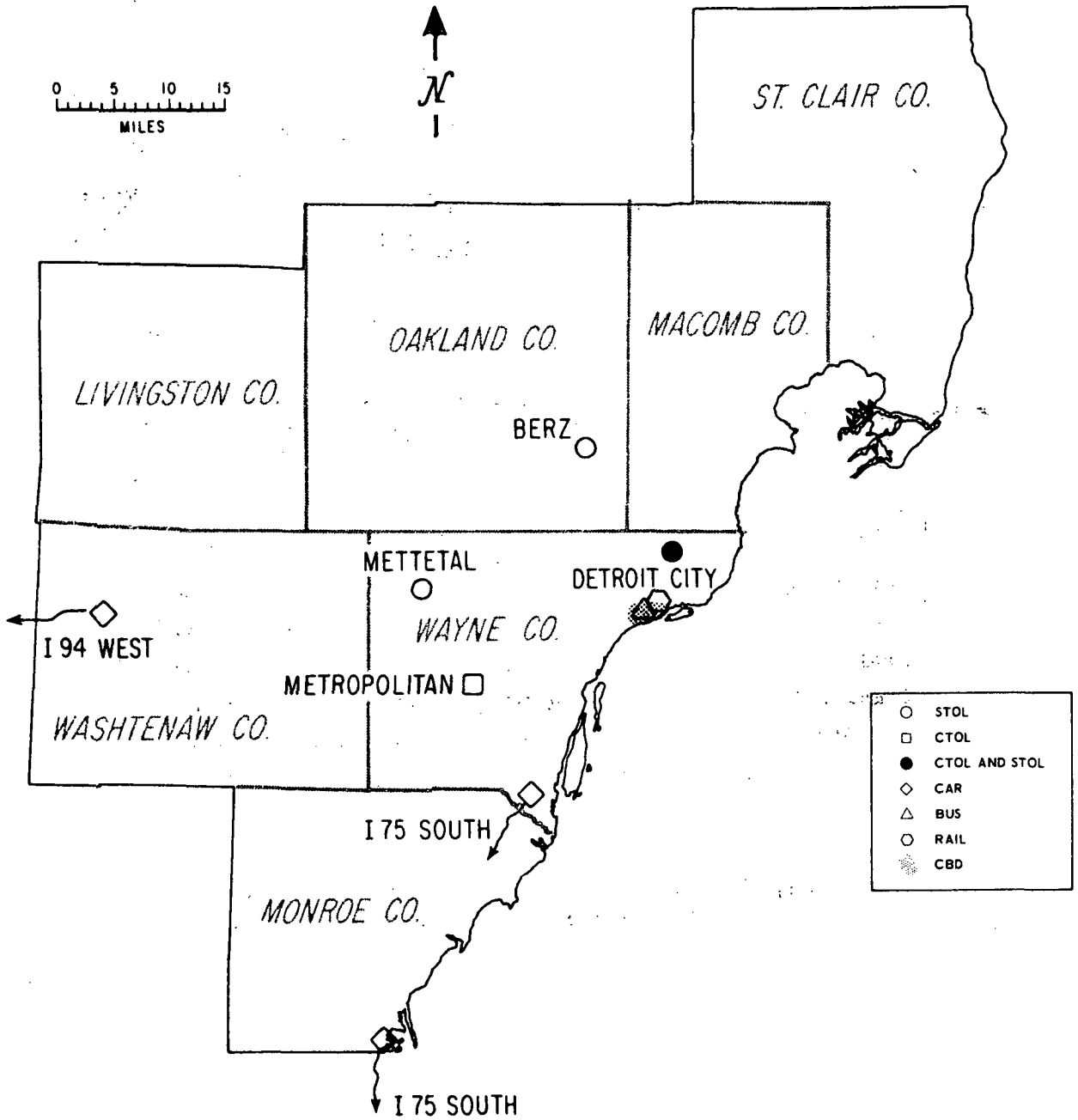

Figure 16. Detroit Region Port Locations

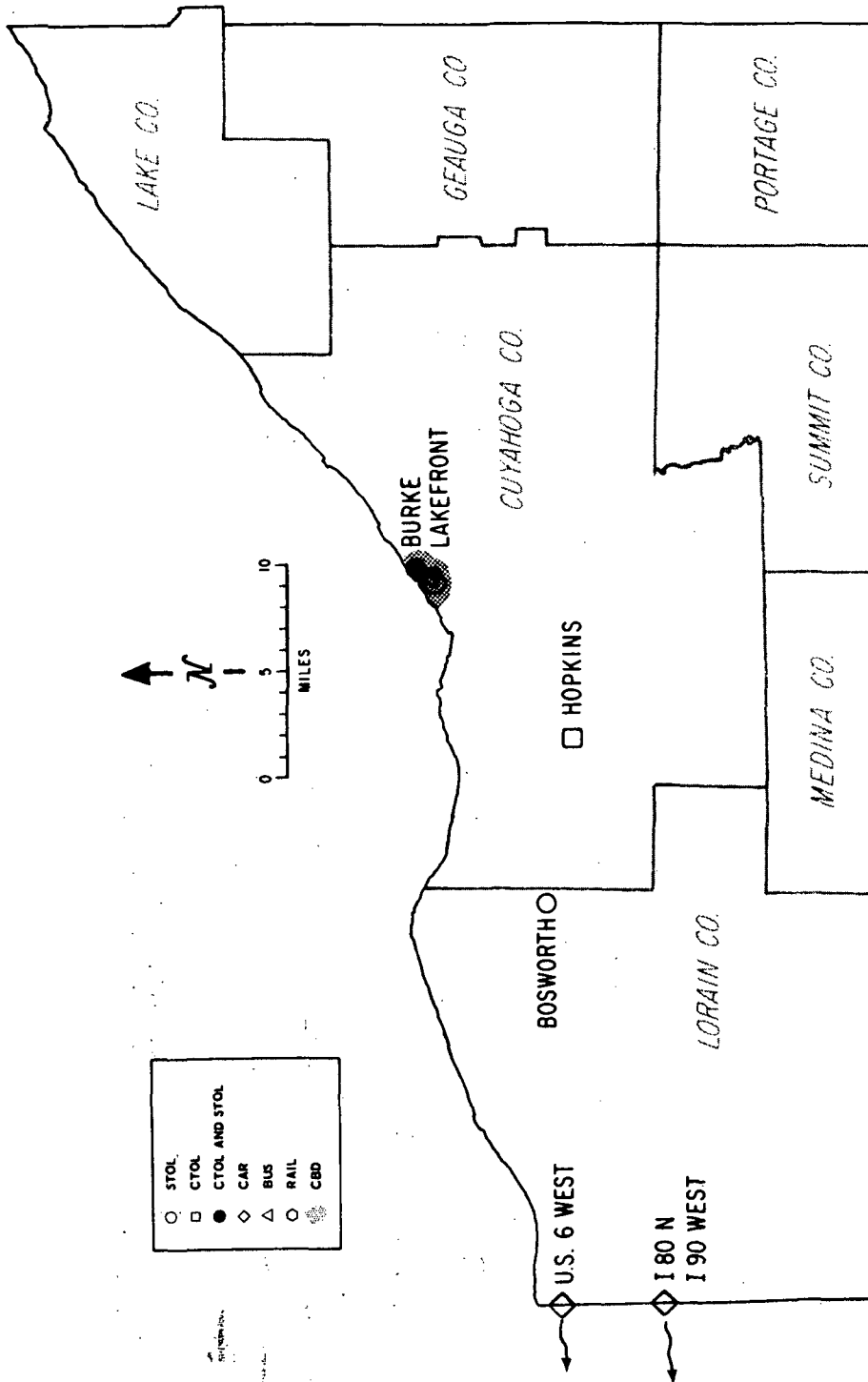

Figure 17. Cleveland Region Port Locations

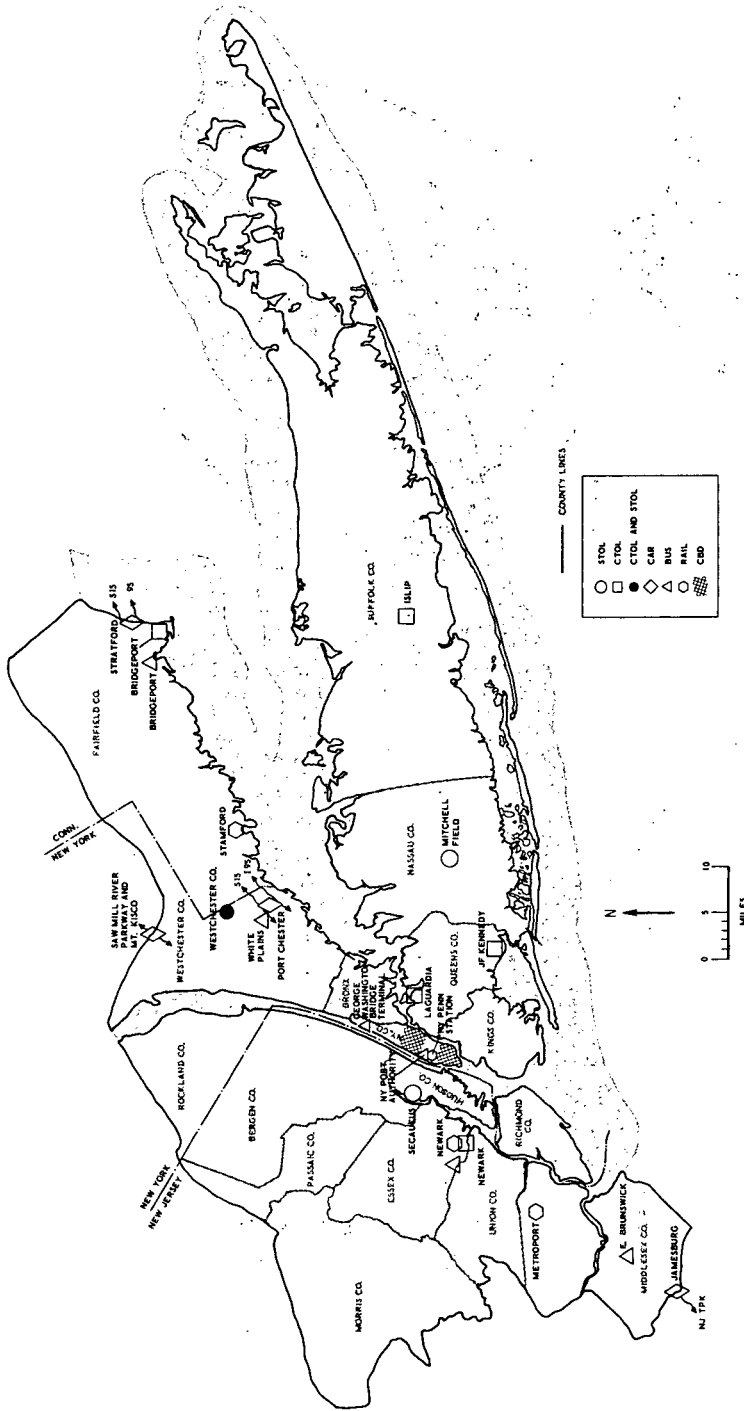

Figure 18. New York Region Port Locations

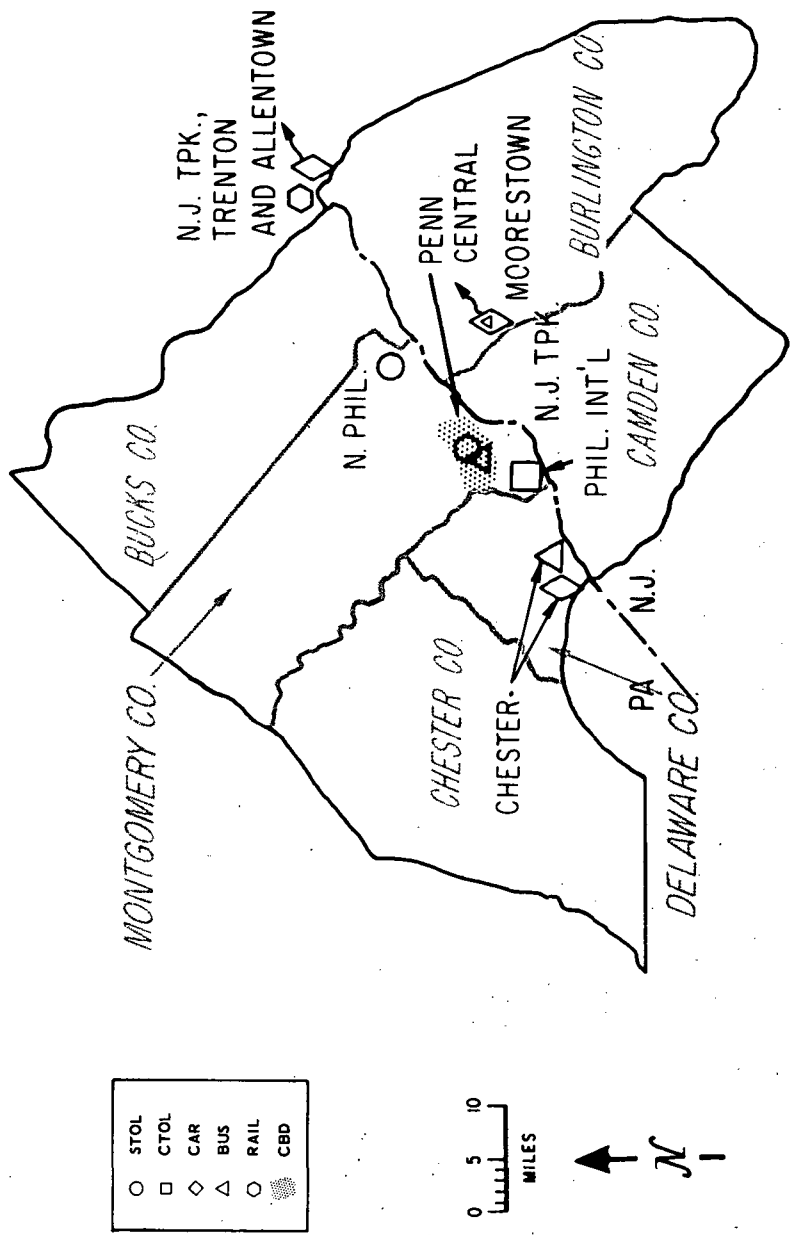

Figure 19. Philadelphia Region Port Locations

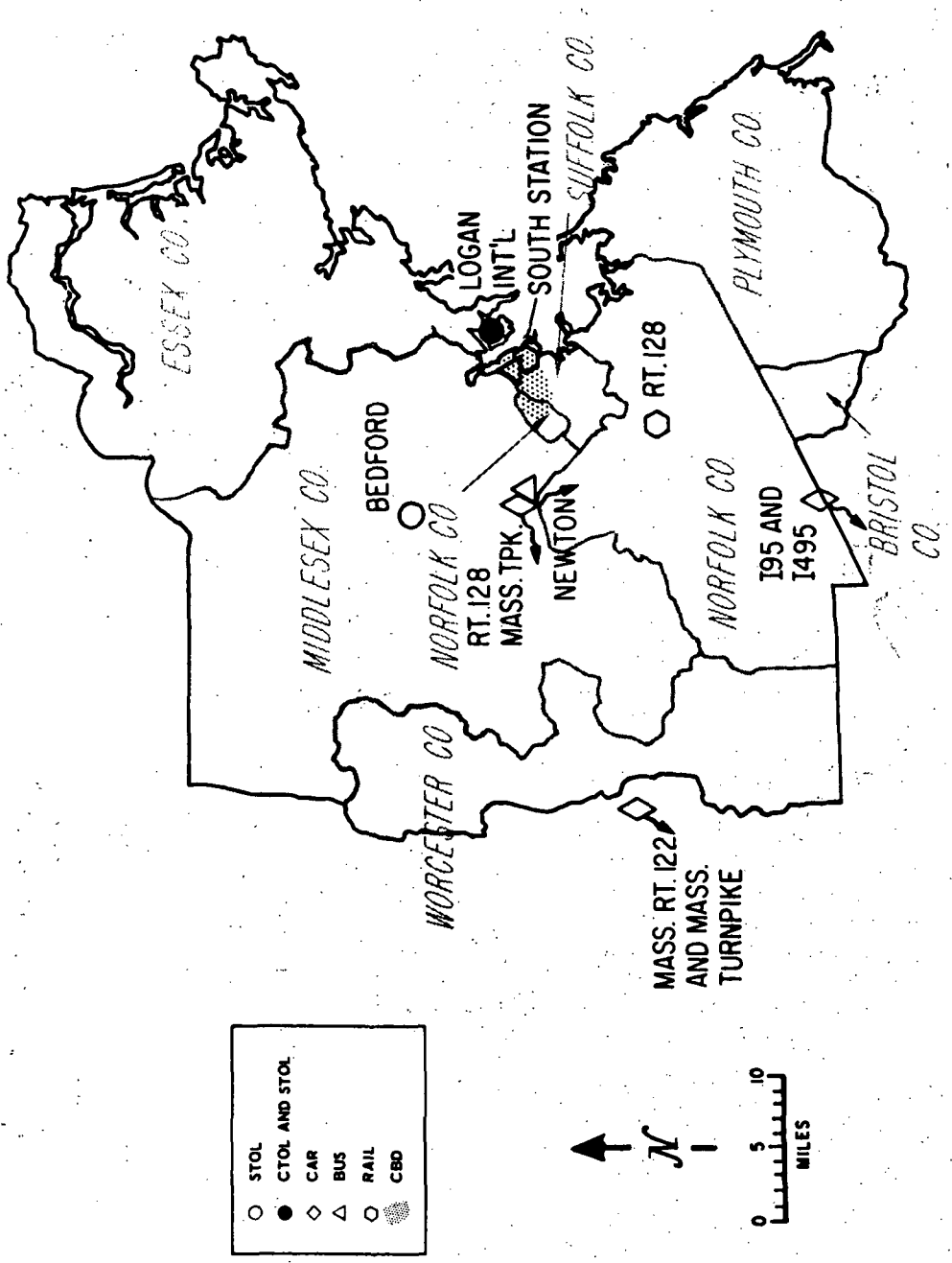

Figure 20. Boston Region Port Locations

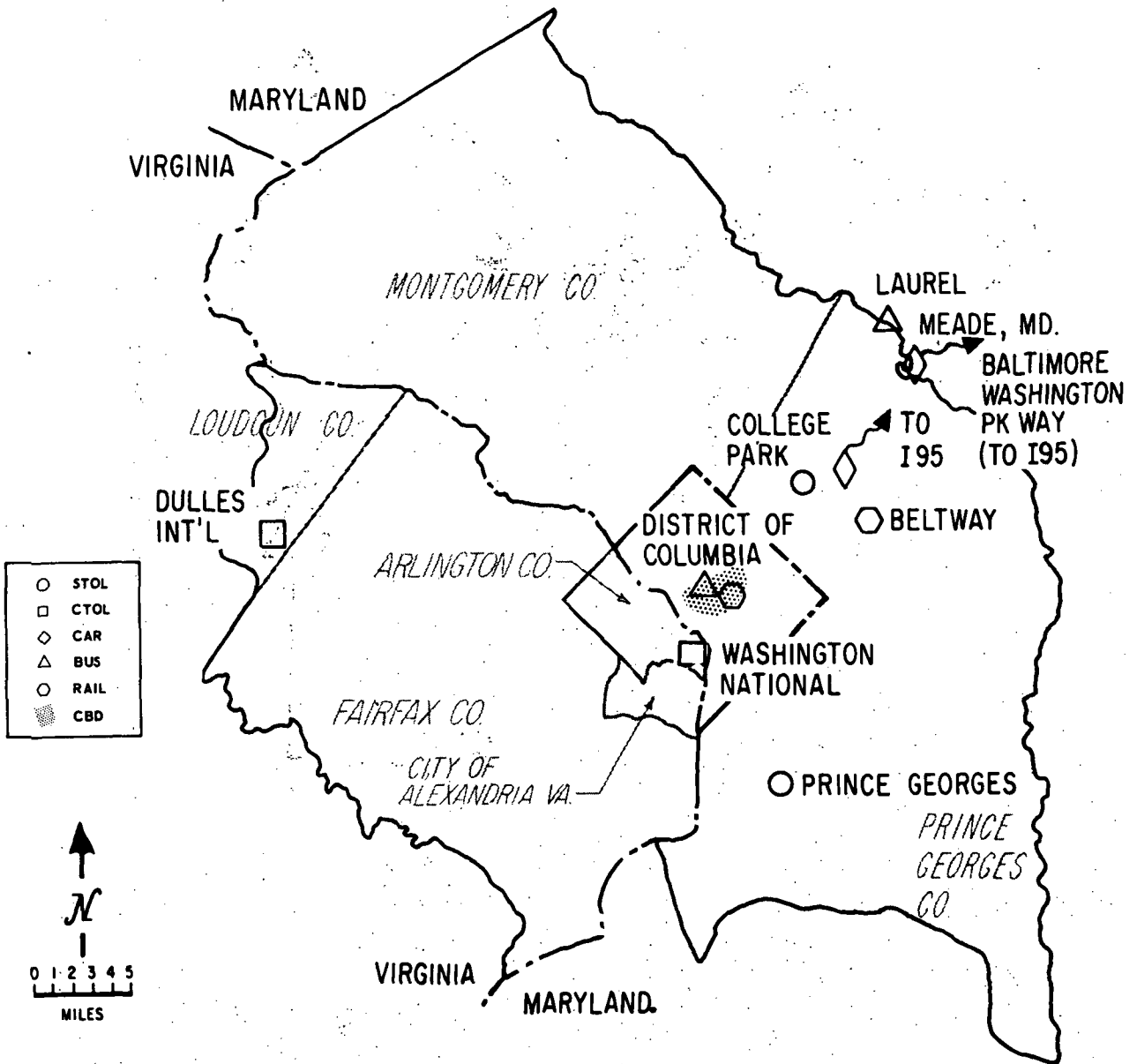

Figure 21. Washington, D.C., Region Port Locations

Page Intentionally Left Blank

VI. RESULTS

The preceding sections of this report have identified the means and supporting data that enable the definition of an optimum STOL system for a given combination of vehicle capacity, return on investment (ROI), and operating arena. In this section, this procedure was applied to different combinations of these parameters and resulted in the identification of a corresponding set of optimum STOL systems. From this information, the sensitivity of demand, fares, and the required fleet size to variations in vehicle capacity and ROI in each of the three arenas was evaluated. These parametric data were then used to help determine a "selected" STOL system in each arena by establishing the preferred range of vehicle capacities. Next, the influence of each arena's CTOL service on STOL system viability and the impact of the selected STOL systems on alternative travel modes and environmental factors were assessed. Finally, the potential for using STOL aircraft (designed for short haul service) over longer nonstop distances was examined.

A. PARAMETRIC SENSITIVITIES

The importance of vehicle size and ROI was assessed by determining the sensitivity of demand for STOL service (i. e., patronage) and the resulting fleet size as functions of these variables for each of the three arenas. The results of this analysis, together with an explanation of the observed trends, are presented in the following paragraphs.

1. STOL SYSTEM DEMAND

Variations in the planned ROI levels directly affect STOL patronage and also influence the selection of candidate city pairs for inclusion in the

STOL system. As indicated in Table 8, all of the 14 city pairs examined were able to produce an ROI = 0 for certain STOL aircraft sizes. However, 3 of the 14 city pairs could not achieve an ROI = 12 percent regardless of aircraft size, and 4 others were aircraft-size constrained.

The variation in the number of economically viable city pairs (city pairs able to produce the specified ROI) contributing to the total California Corridor demand account for some of the discontinuities in STOL patronage as shown in Figure 22. The remaining discontinuities can be attributed to variations in the optimum number of service paths selected for each city pair. The impact of the number of Los Angeles-San Francisco service paths on the California Corridor demand is illustrated by the three discontinuities of the ROI = 5.25 percent contour in Figure 22. The maximum

Table 8. STOL System Economic Viability Comparison

City Pair	Range of STOL Aircraft Sizes Able to Produce Specified Levels of Return on Investment			
	ROI = 0%	ROI = 5.25%	ROI = 8%	ROI = 12%*
LA-SF	All	All	All	80 to 200
LA-SAC	All	All	All	80 to 200
LA-SD	70 to 190	NV	NV	NV
SF-SD	All	All	All	All
SF-SAC	50 to 170	50 to 110	NV	NV
SD-SAC	50 to 110	All	50 to 90	NV
CHI-CLV	All	All	All	All
CHI-DET	All	All	All	All
DET-CLV	50 to 180	50 to 150	50 to 130	50 to 110
NY-BOS	All	All	All	All
NY-WASH	All	All	All	All
WASH-BOS	All	All	All	All
WASH-PHIL	All	All	All	50 to 180
BOS-PHIL	All	All	All	All

All - All sizes examined (50 to 200) produced the specified ROI
 NV - Nonviable, none of the sizes examined produced the specified ROI
 * - 12.5% in California corridor

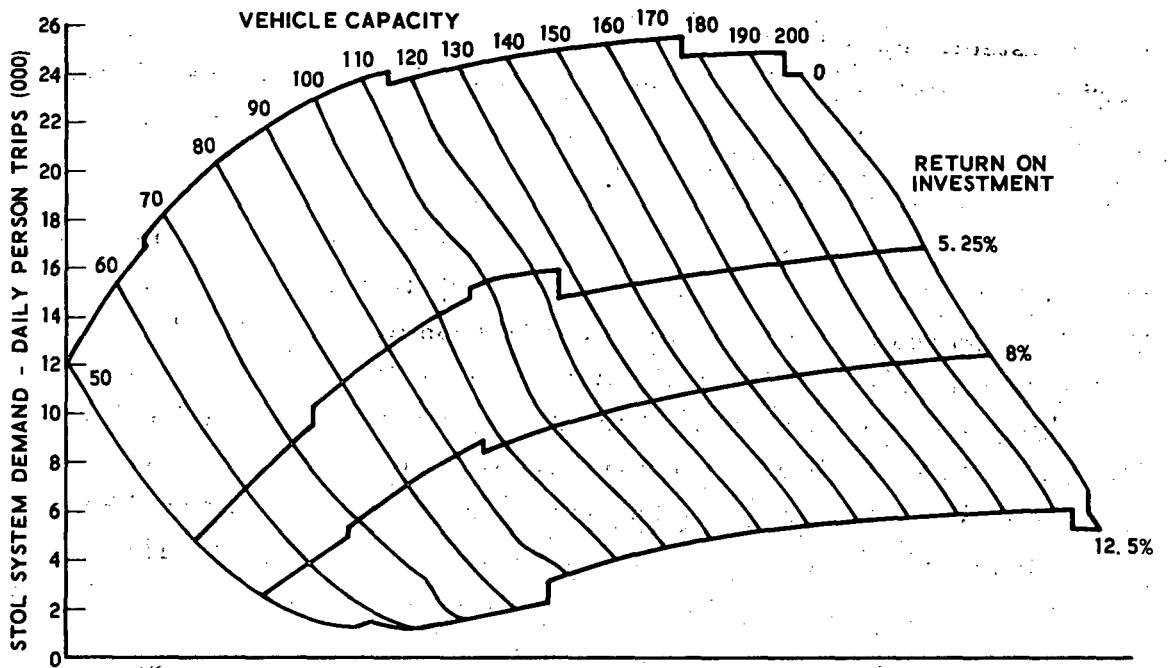

Figure 22. STOL Patronage, California Corridor

number of service paths that could produce a 5.25 percent ROI for STOL operations between the Los Angeles and San Francisco regions was 6, with the exception of vehicle sizes between 50 and 75* passengers where the number of service paths dropped to 3, and between vehicle sizes of 105 and 125 passengers where the number of service paths increased to 8. The preferred number of service paths in each city pair of the California Corridor, as determined for selected combinations of vehicle sizes and ROI, is presented in Table 9.

*Discontinuities were assumed to take place at the midpoint between the computed data points. Since only vehicle sizes that were multiples of 10 (passengers) were simulated, the midpoint always occurred at an odd multiple of 5.

Table 9. Optimum Number of STOL Service Paths, California Corridor

LOS ANGELES - SAN FRANCISCO				LOS ANGELES - SAN DIEGO			
VEHICLE CAPACITY NO. / ROI, % PASS	50	100	150	200	RANK ORDER	L. A. PORT	S. F. PORT
12.50	NV	1	1	1	1	PATTON	INDIA BASIN
8.00	1	2	2	2	2	PATTON	PALO ALTO
5.25	3	3	3	3	3	FULLERTON	INDIA BASIN
0	6	6	6	6	4	PATTON	CONCORD
	8	8	8	8	5	TRI CITY	INDIA BASIN
					6	FULLERTON	PALO ALTO
					7	VAN NUYS	INDIA BASIN
					8	VAN NUYS	PALO ALTO

SAN FRANCISCO - SACRAMENTO				SAN FRANCISCO - SAN DIEGO			
VEHICLE CAPACITY NO. / ROI, % PASS	50	100	150	200	RANK ORDER	S. F. PORT	SAC PORT
12.50	NV	NV	NV	NV	1	INDIAN BASIN	EXECUTIVE
8.00	NV	NV	NV	NV	2	PALO ALTO	MONTGOMERY
5.25	1	1	1	1	3	CONCORD	MONTGOMERY
0	1	1	1	1			

SAN FRANCISCO - SACRAMENTO				LOS ANGELES - SACRAMENTO			
VEHICLE CAPACITY NO. / ROI, % PASS	50	100	150	200	RANK ORDER	L. A. PORT	SAC PORT
12.50	NV	NV	NV	NV	1	PATTON	MONTGOMERY
8.00	1	1	1	1	2	PATTON	MONTGOMERY
5.25	1	1	1	1	3	PATTON	MONTGOMERY
0	1	1	1	1			

SAN DIEGO - SACRAMENTO				LOS ANGELES - SACRAMENTO			
VEHICLE CAPACITY NO. / ROI, % PASS	50	100	150	200	RANK ORDER	L. A. PORT	SAC PORT
12.50	NV	NV	NV	NV	1	PATTON	MONTGOMERY
8.00	1	1	1	1	2	PATTON	MONTGOMERY
5.25	1	1	1	1	3	PATTON	MONTGOMERY
0	1	1	1	1			

○ NUMBER OF STOL SERVICE PATHS, INCLUDING THOSE SERVICE PATHS OF THAT RANK ORDER AND HIGHER
 NV NONVIABLE, I. e., STOL SYSTEM COULD NOT PRODUCE STIPULATED ROI

Unlike the city pairs of the California Corridor, two of the Midwest Triangle city pairs, Chicago-Detroit and Chicago-Cleveland, supported STOL service to such an extent that, as shown in Table 8, an ROI of at least 12 percent could be achieved over the entire range of vehicle capacities. The remaining city pair, Detroit-Cleveland, was viable only when using the smaller vehicle sizes. The discontinuity in the STOL patronage demand shown in Figure 23 was due to the elimination of the Detroit-Cleveland demand component for the larger vehicle sizes and provides an interesting illustration of the impact of ROI on city pair viability. At an ROI of 12 percent, STOL service between Detroit-Cleveland becomes nonviable when using vehicles

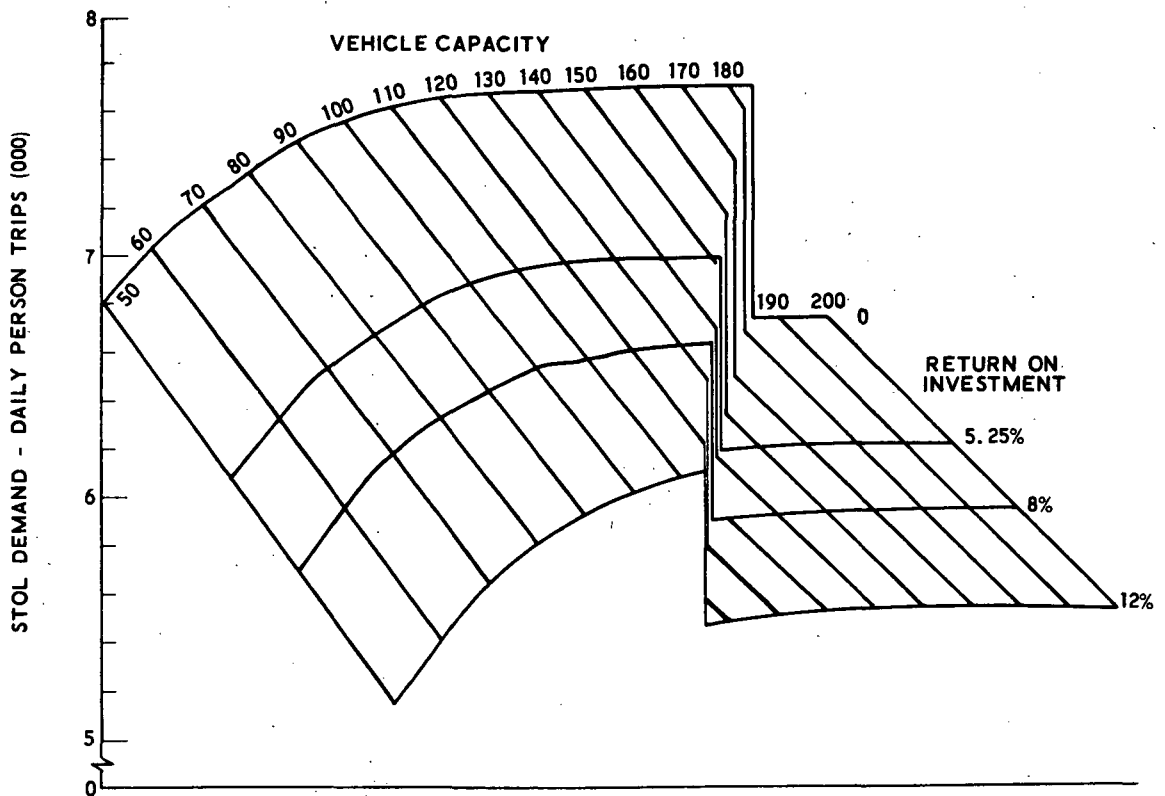

Figure 23. STOL Patronage, Midwest Triangle

larger than 115 passengers. When the ROI requirement is lowered to 0 percent, Detroit-Cleveland STOL service can maintain viability with vehicles as large as 185 passengers. The preferred number of service paths for each of the Midwest Triangle city pairs is defined in Table 10 as a function of vehicle size and ROI.

As defined for this study, the Northeast Corridor arena consisted of five city pairs (New York-Washington, D.C., New York-Boston, Boston-Washington, D.C., Philadelphia-Boston, and Philadelphia-Washington, D.C.). Only one city pair, Philadelphia-Washington, D.C., could not support STOL service using large vehicles at high ROIs. This accounts for the drop in demand in this region of the plot displayed in Figure 24. The preferred STOL service paths between the city pairs of the Northeast Corridor are defined in Table 11 for selected combinations of vehicle capacity and ROI.

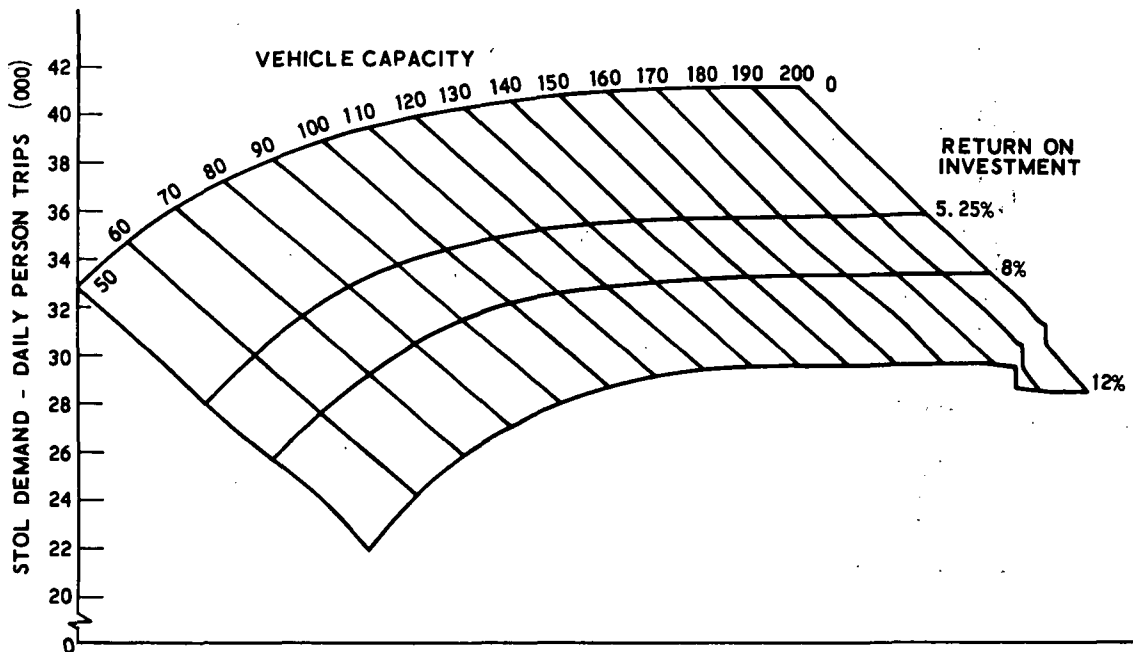

Figure 24. STOL Patronage, Northeast Corridor

Table 10. Optimum Number of STOL Service Paths, Midwest Triangle

		CHICAGO - DETROIT				CHICAGO - CLEVELAND			
VEHICLE CAPACITY NO. / ROI, % / PASS	RANK ORDER	CHI PORT		DET PORT		CHI PORT		CLEV PORT	
		MEIGS	MITCHEL	DETROIT CITY	METTETAL	MEIGS	MITCHEL	BURKE LAKEFRONT	BOSWELL
12.00	1	④	④	①	①	③	③	①	①
8.00	2	④	④	②	②	②	②	①	①
5.25	3	④	④	③	③	③	③	①	①
0	4	④	④	④	④	④	④	①	①

		DETROIT - CLEVELAND			
VEHICLE CAPACITY NO. / ROI, % / PASS	RANK ORDER	DET PORT		CLEV PORT	
		DETROIT CITY	BURKE LAKEFRONT	DETROIT CITY	BURKE LAKEFRONT
12.00	1	①	①	①	①
8.00		①	①	①	①
5.25		①	①	①	①
0		①	①	①	①

○ NUMBER OF STOL SERVICE PATHS, INCLUDING THOSE SERVICE PATHS OF THAT RANK ORDER AND HIGHER
 NV NONVIABLE, I. e., STOL SYSTEM COULD NOT PRODUCE STIPULATED ROI

Table 11. Optimum Number of STOL Service Paths, Northeast Corridor

NEW YORK - WASHINGTON

VEHICLE CAPACITY NO. / ROI, % / PASS	NEW YORK - WASHINGTON		NY PORT		WASH PORT	
	50	100	150	200	50	100
12.00	5	5	5	4	SECAUCUS	COLLEGE PARK
8.00	3	3	3	4	MITCHELL	COLLEGE PARK
5.25	3	3	3	4	WESTCHESTER CO	COLLEGE PARK
0	3	3	3	4	SECAUCUS	PG AIRPARK
				5	MITCHELL	PG AIRPARK

NEW YORK - BOSTON

VEHICLE CAPACITY NO. / ROI, % / PASS	NEW YORK - BOSTON		NY PORT		BOS PORT	
	50	100	150	200	50	100
12.00	4	4	4	4	SECAUCUS	LOGAN
8.00	3	3	3	4	MITCHELL	LOGAN
5.25	4	4	4	4	WESTCHESTER CO	LOGAN
0	3	3	3	4	SECAUCUS	BEDFORD
				4	MITCHELL	BEDFORD

BOSTON - WASHINGTON

VEHICLE CAPACITY NO. / ROI, % / PASS	BOSTON - WASHINGTON		BOS PORT		WASH PORT	
	50	100	150	200	50	100
12.00	4	4	4	4	LOGAN	COLLEGE PARK
8.00	3	3	3	3	LOGAN	COLLEGE PARK
5.25	3	3	3	3	LOGAN	PG AIRPARK
0	3	3	3	4		

PHILADELPHIA - BOSTON

VEHICLE CAPACITY NO. / ROI, % / PASS	PHILADELPHIA - BOSTON		PHILA PORT		BOS PORT	
	50	100	150	200	50	100
12.00	2	2	2	1	NORTH PHILA	LOGAN
8.00	2	2	2	1	NORTH PHILA	BEDFORD
5.25	2	2	2	1		
0	2	2	2	1		

PHILADELPHIA - WASHINGTON

VEHICLE CAPACITY NO. / ROI, % / PASS	PHILADELPHIA - WASHINGTON		PHILA PORT		WASH PORT	
	50	100	150	200	50	100
12.00	1	1	1	1	NORTH PHILA	COLLEGE PARK
8.00	1	1	1	1		
5.25	1	1	1	1		
0	1	1	1	1		

○ NUMBER OF STOL SERVICE PATHS, INCLUDING THOSE SERVICE PATHS OF THAT RANK ORDER AND HIGHER
 NY NONVIABLE, I. E., STOL SYSTEM COULD NOT PRODUCE STIPULATED ROI

2. STOL SYSTEM FARES

The one-way fares determined for each city pair, weighted by revenue passenger miles, were used to compute an average fare rate in cents per mile for each of the three arenas. The variations of these fare rates with vehicle capacity and ROI are illustrated in Figures 25 through 27. These fare rate values are influenced primarily by the operating costs and block distances of the routes comprising a given arena and, to a lesser degree, the fares of the competitive modes. Thus, in the California Corridor, where indirect operating costs were lower (Section IV.C.2), block distances longer, and competitive travel costs lower, the STOL system fare structure was from two to three cents per mile lower than the STOL fares of either the Midwest Triangle or the Northeast Corridor for comparable vehicle capacity-ROI combinations.

The higher seat-mile operating costs inherent in the smaller vehicles (Figure 7) resulted in relatively higher fare rates. The added flexibility of 50- to 100-passenger vehicles, conceptually encouraging operations over

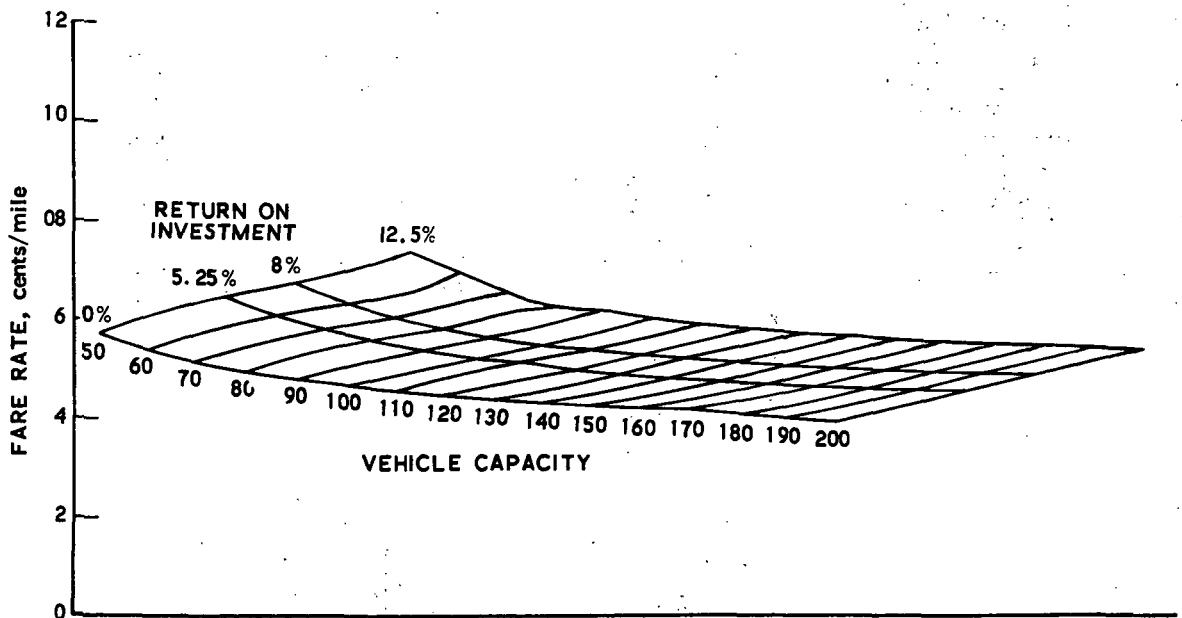

Figure 25. Fare Structure, California Corridor

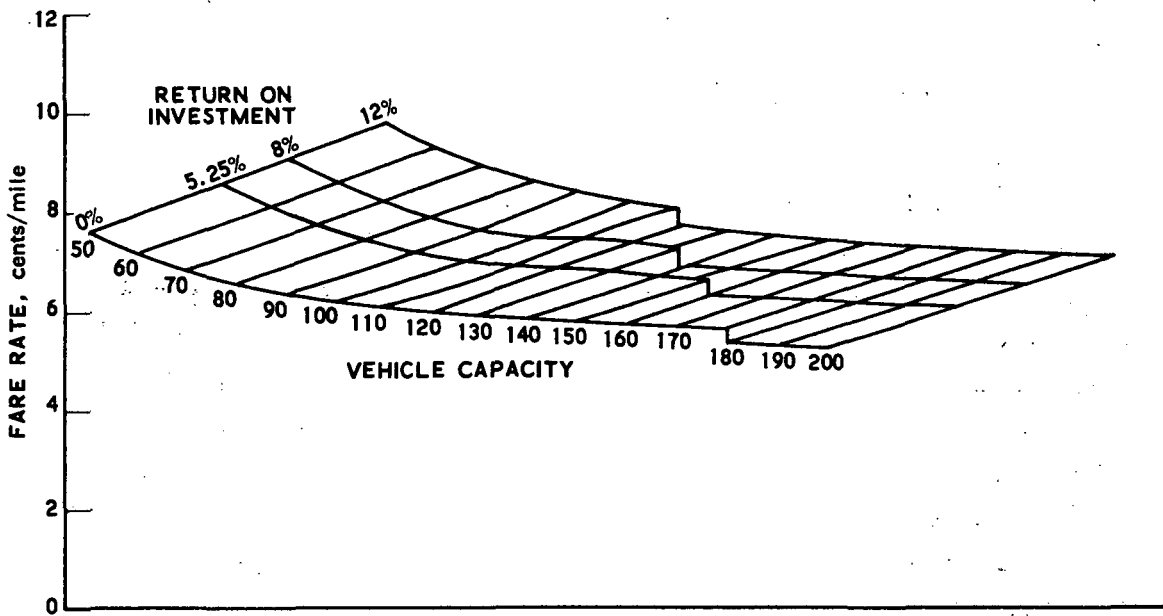

Figure 26. Fare Structure, Midwest Triangle

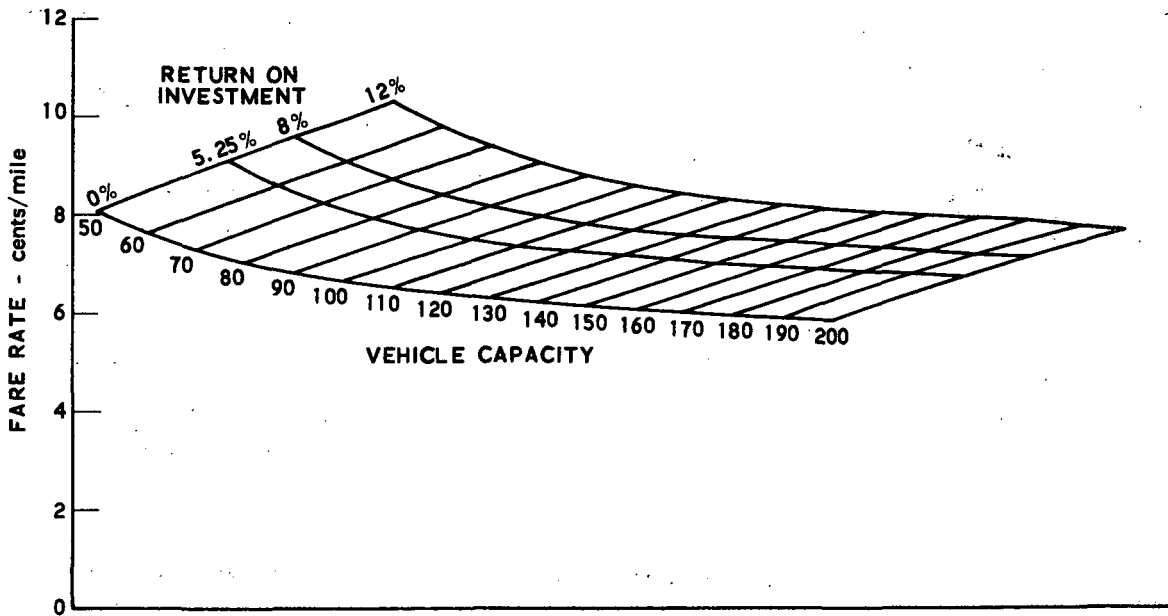

Figure 27. Fare Structure, Northeast Corridor

more service paths and higher frequency of service, apparently did not, however, enhance STOL service attributes to the degree necessary to compensate for the higher fares.

3. ARENA COMPARISON

A measure of the potential for STOL success in each arena can be obtained by comparing STOL demand with 1980 patronage predicted for CTOL in the absence of STOL competition. This CTOL patronage is the sum of that demand derived for each of the candidate city pairs comprising an arena and, unlike the STOL system, includes all candidate city pairs regardless of their ability to provide a reasonable ROI for the CTOL operator. The projected average daily 1980 CTOL demand levels were 26,400, 4,180, and 18,510 person trips for the California Corridor, Midwest Triangle, and Northeast Corridor, respectively. A comparison of CTOL (no STOL) with STOL demand levels is illustrated in Figure 28 which displays the outer contours of arena demand plots of Figures 22 through 24. STOL demand levels are seen to exceed CTOL (no STOL) patronage over the entire spectrum of STOL vehicle capacities and ROIs in both the Midwest Triangle and the Northeast Corridor. The reverse was true in the California Corridor with CTOL (no STOL) demand exceeding the maximum STOL demand levels. It should be noted that these relatively low California Corridor STOL demand levels occurred in spite of the fact that the STOL fare rates were lower than those in either of the other two arenas studied. Notwithstanding the difference in fare rates determined for each arena, the spread in fare rates over the entire spectrum of vehicle capacities and ROIs for any one arena was reasonably consistent. The minimum fare (200-passenger vehicle capacity, 0 percent ROI) was roughly one-half of the maximum fare (50-passenger vehicle capacity, 12 percent ROI). The sensitivity of STOL demand to this fare variation was an order of magnitude greater in the California Corridor than that observed in either of the other two arenas.

This difference in fare sensitivity can be attributed to the differences in the competitive CTOL systems. In the Midwest Triangle and Northeast

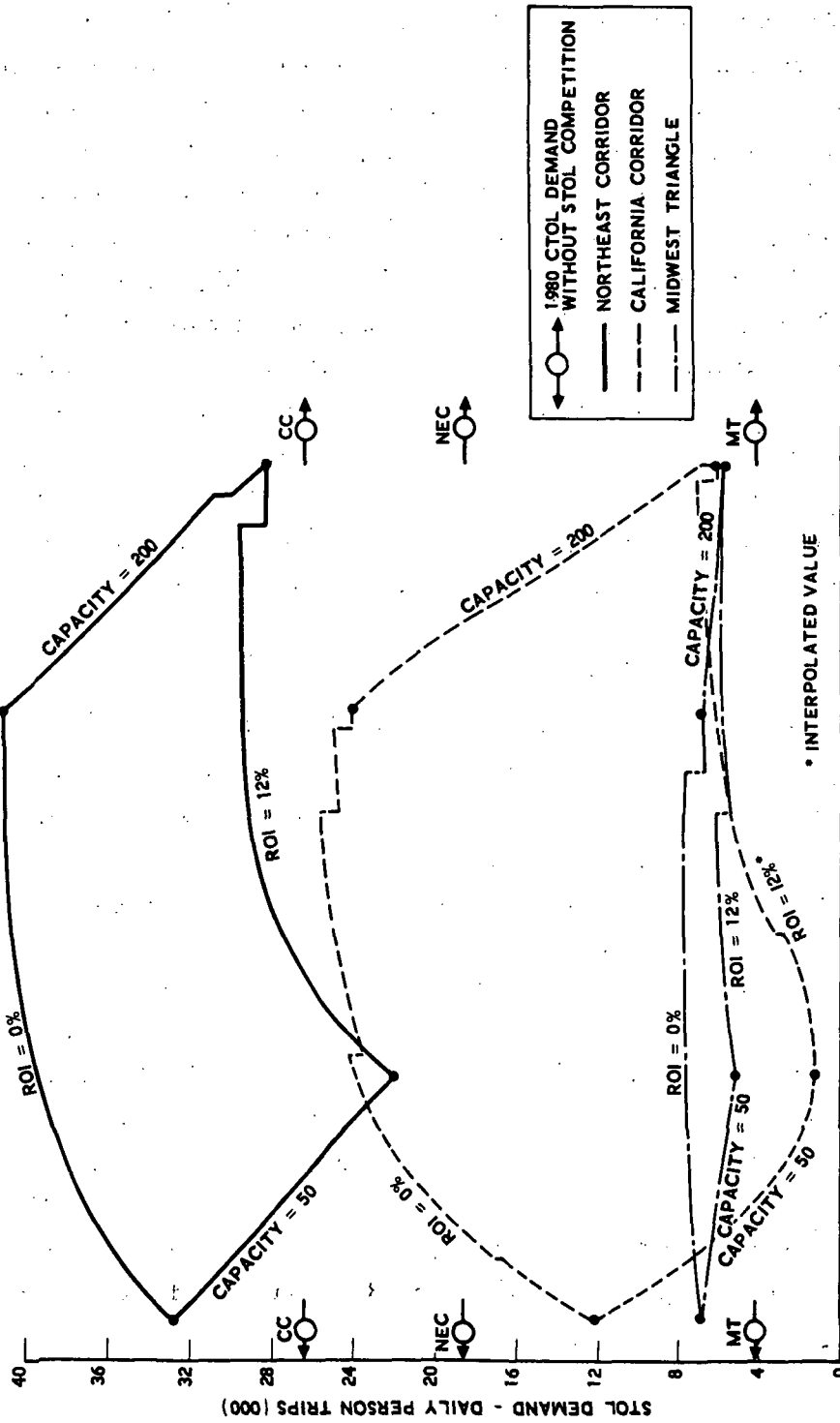

Figure 28. Comparison of Arena STOL Demand Sensitivities

Corridor, the CTOL systems paid for congestion with longer block times and correspondingly higher fares. This congestion was not as prevalent in the California Corridor CTOL system. As a result, in the California Corridor the CTOL system was highly competitive and, depending on the STOL fare, could retain virtually all or none of its 1980 "no STOL" demand potential. This shifting of air travelers between the CTOL and STOL systems accounts for the large variation in STOL demand as a function of vehicle capacity and ROI. In both the Midwest Triangle and the Northeast Corridor, the STOL system was sufficiently attractive, even at high fares, to capture most of the air (CTOL) travelers. The increase in total air demand at the lower fares in those arenas was primarily due to the diversion of nonair (i. e., car, bus, and rail) travelers to STOL. A more detailed discussion of this phenomenon is presented in Section VI. B. The sensitivity of origin and destination patronage for individual city pairs is presented in Volume II, Appendix D (Ref. 3).

4. STOL FLEET SIZE REQUIREMENTS

The interaction of demand, vehicle capacity, block time, gate time, and aircraft utilization [discussed in Volume II, Appendix A (Ref. 3)] dictated the fleet size requirements illustrated in Figures 29 through 31 for the California Corridor, Midwest Triangle, and Northeast Corridor, respectively. Where demand levels varied only moderately over the range of vehicle capacities (not greater than 25 percent relative to the demand levels of the 100-passenger vehicle) for a given ROI, such as in the Midwest Triangle and the Northeast Corridor, fleet size requirements increased with smaller vehicle sizes and produced the curves illustrated in Figures 30 and 31. In the California Corridor, however, the demand levels associated with the 50-passenger vehicle ranged between 33 to 50 percent of the 100-passenger configuration patronage. This demand drop-off rate more than compensated for the reduction in the vehicle capacity, resulting in lower fleet requirements identified for the smaller vehicles, and the slope reversal of the ROI contours displayed in Figure 29.

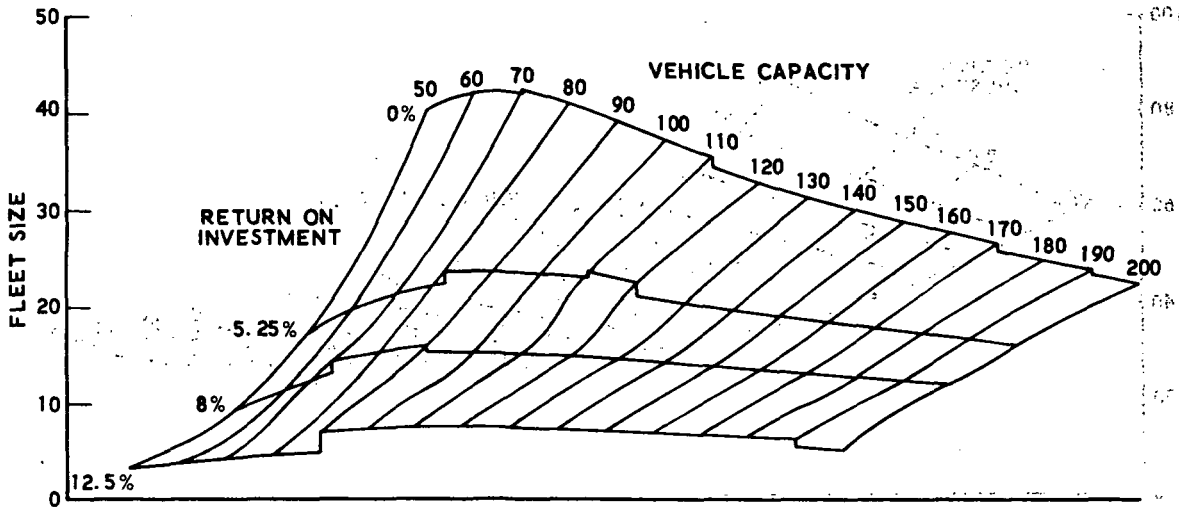

Figure 29. Fleet-Size Requirements, California Corridor

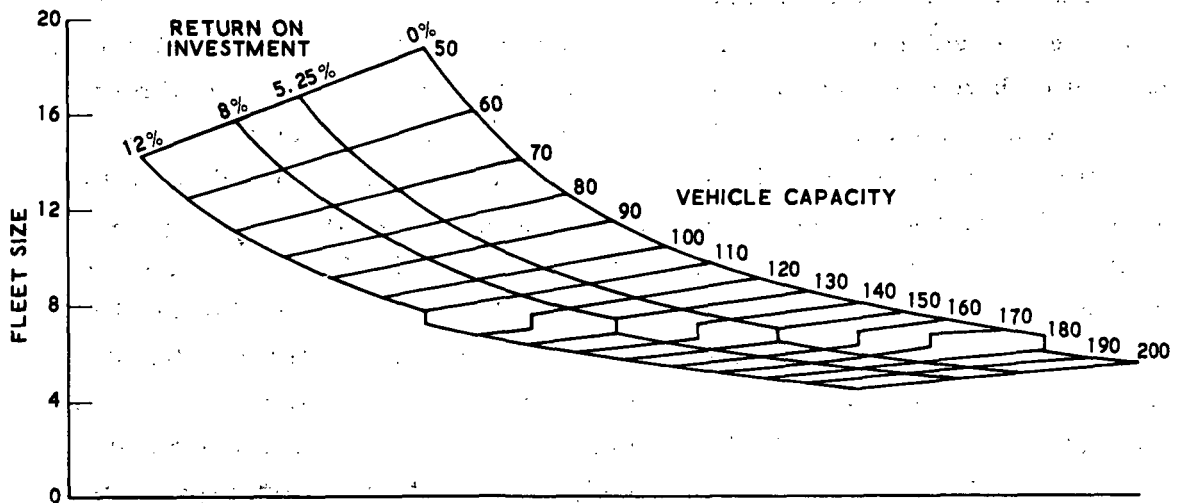

Figure 30. Fleet-Size Requirements, Midwest Triangle

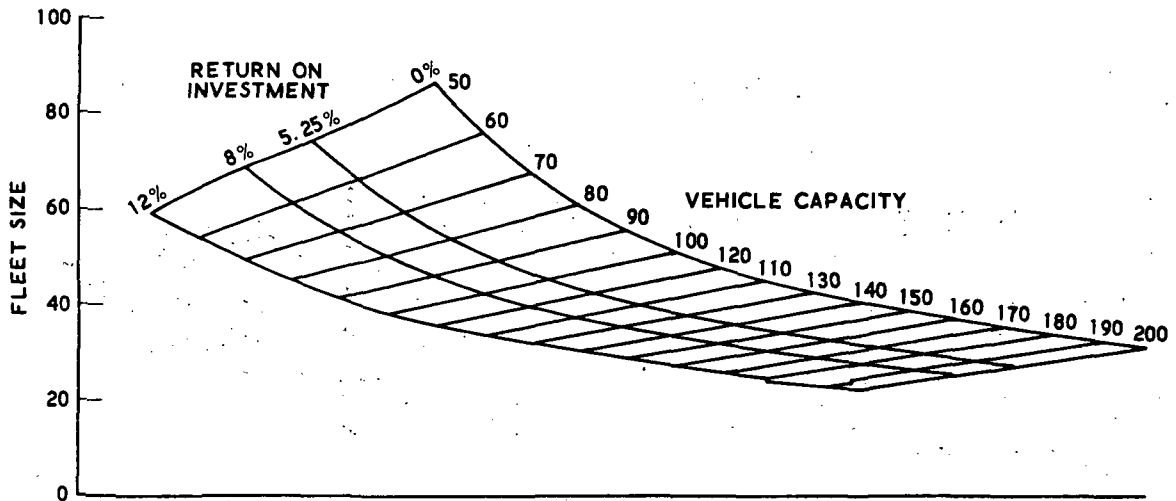

Figure 31. Fleet-Size Requirements, Northeast Corridor

B. SELECTED SYSTEM DEFINITION

In the preceding section the results were presented parametrically as a function of both vehicle size and ROI. To facilitate the presentation of more detailed results, a specified STOL system was defined by selecting a single combination of these two variables. While results of this study indicated the greatest STOL patronage occurred when operating with a fleet of 200-passenger aircraft, the potential viability of short haul high-density STOL service would not be markedly altered by the use of aircraft whose size was within the 100- to 200-passenger range. Hence, to permit comparison with the results of other STOL studies that have focused on the 150-passenger size, that size was also selected for a more detailed examination in this study. An 8-percent ROI was selected as a representative level, since that value corresponds to an 11-percent return on stockholder equity, which in turn approximates the

10.4 percent average experienced in the U.S. economy during the 1969/1967 period (Ref. 23).

1. SYSTEM CHARACTERISTICS

a. California Corridor

Because of the relative attractiveness of the intrastate CTOL system in the California Corridor, the selected STOL system could achieve the desired ROI (eight percent) in only three of the six candidate city pairs. When using a 150-passenger vehicle, the system generated maximum ROIs of between one and two percent for the two contiguous city pairs of Los Angeles-San Diego and San Francisco-Sacramento. STOL operations serving the city pair with the lowest total intercity travel demand (1094 daily person trips, San Diego-Sacramento) produced a negative ROI. The selected STOL system is, therefore, structured to serve only the three economically viable city pairs: Los Angeles-San Francisco, San Francisco-San Diego, and Los Angeles-Sacramento.

The system utilizes two STOLports in each of the Los Angeles and San Francisco regions and one each in the San Diego and Sacramento regions. Sufficient STOL demand was generated between Los Angeles and San Francisco to support operations over three service paths, while the San Francisco-San Diego and Los Angeles-Sacramento city pairs utilized two paths and one service path, respectively.

An estimated \$156 million investment would be required to purchase the fleet of fourteen 150-passenger aircraft and the supporting equipment needed to provide STOL service in the California Corridor. Operation of these aircraft would produce 118 flights per day over the six-service-path route structure, carrying an average of 6302 daily passengers. Fares averaging 5.07 cents per mile, obtained by weighting revenue passenger miles, would result in an annual profit before taxes of \$10 million, yielding the desired return on investment of 8 percent.

Table 12 identifies a number of operational and economic characteristics for each of the California Corridor service paths. The relatively high demand observed on the Fullerton-India Basin service path can be attributed to the higher fares associated with competitive CTOL service operating out of the closest Los Angeles Region CTOLport, Orange County.

Table 13 identifies the annual STOL system aircraft departures and origin and destination passengers forecast for each port. STOLport capital improvements necessary to support the specified level of STOL service is also defined for each port. The total STOL-induced port developments required for California are estimated to cost \$18 million. The \$50,000 associated with Sacramento Executive Airport is for an environmental impact report required prior to inauguration of commercial scheduled service.

Table 12. Selected STOL System Service Characteristics, California Corridor

City Pair	STOL Service Path	Block Distance (st mi)	Block Time (hr/min)	Fare (\$)	Service Frequency (round trips per day)	Demand (daily person trips)	Percent of Total Intercity Demand	Revenue (\$/day)	Operating Costs (\$/day)
(1)	(2)								(3)
LA-SF				18.28	33	6302	16.7	106,676	91,561
	LA1-SF1	347	0:56		9	1730	4.6		
	LA1-SF2	324	0:53		10	1866	4.9		
	LA2-SF1	362	0:58		14	2706	7.2		
SF-SD				18.63	17	3434	53.6	65,799	56,439
	SF1-SD1	448	1:07		10	2046	31.9		
	SF2-SD1	424	1:04		7	1388	21.7		
LA-SAC				20.69	9	1664	24.3	28,697	24,630
	LA1-SAC1	360	0:57		9	1664	24.3		
(1) CITY		(2) PORT		(3) Port-related IOC = \$164.37 per departure included in operating costs					
Los Angeles	LA	Patton	LA1						
San Francisco	SF	Fullerton	LA2						
San Diego	SD	India Basin	SF1						
Sacramento	SAC	Palo Alto	SF2						
		Montgomery	SD1						
		Executive	SAC1						

Table 13. Selected STOL System STOLport Requirements, California Corridor

Port City	Annual Passengers	Annual Departures	Capital Costs (\$000)		Physical Change			
			Airfield	Terminal	Site Acq.	New Field	New Term.	Field Aug.
TOTAL			9,245	8,861				
LOS ANGELES	2,907,724	14,911	3,015	3,104				
Patton	1,920,262	9,847	2,700	2,051	X	X	X	
Fullerton	987,462	5,064	315	1,053			X	X
SAN FRANCISCO	3,554,814	18,226	5,884	3,767				
India Basin	2,366,223	12,135.47	5,599	2,508	X	X	X	
Palo Alto	1,187,791	6,001.24	285	1,259			X	X
SAN DIEGO	1,253,509	6,428	296	1,326				
Montgomery	1,253,509	6,428	296	1,326			X	X
SACRAMENTO	607,219	3,114	50	664				
Executive	607,219	3,114	50	664			X	

b. Midwest Triangle

A STOL system operating between Detroit and Cleveland (constrained to a minimum of four round trips per day) produced a maximum ROI of 6.1 percent, falling short of the desired 8-percent level. As a result, the Detroit-Cleveland city pair was excluded from the selected STOL system configured to serve the Midwest Triangle. The resulting STOL system utilizes Meigs Field in Chicago, Detroit City and Mettetal in the Detroit region, and Burke Lakefront in Cleveland. Demand for STOL service was adequate to support two routes or service paths between Chicago and Detroit and a single service path between Chicago and Cleveland.

An estimated \$71 million investment would be required to acquire the fleet of six 150-passenger aircraft and the supporting equipment required to operate the selected STOL system between the two economically viable city pairs of the Midwest arena. These aircraft would provide 60 flights per day over the three-service-path route structure. The anticipated 5921 daily

passengers would pay fares whose weighted average was 6.78 cents per mile, producing annual profits estimated at \$5 million, before taxes.

Operational and economic characteristics of the selected STOL system segregated by service path are presented in Table 14; STOLport facility requirements are shown in Table 15. Although STOL-induced construction requirements in the Midwest (\$5 million) are less than one-third of those required in the California Corridor, the port-related IOC per departure is 50-percent higher. This reflects higher port and airline operating costs in the Midwest Triangle and the Northeast Corridor than those prevalent in the California Corridor.

c. Northeast Corridor

All of the five candidate city pairs in the Northeast Corridor generated sufficient demand to produce an 8-percent ROI using a 150-passenger aircraft and were, therefore, included as part of the selected STOL system. The high level of STOL demand prevalent in this arena made possible the use of multiple STOLports in three of the four Northeast Corridor cities. Secaucus, Mitchell, and Westchester County were sited in the New York region; North Philadelphia was sited in Philadelphia; Logan International and Bedford were sited in Boston; and College Park and Prince Georges Airpark were sited in the Washington, D.C. region. STOL patronage was maximized by using four service paths between New York and Washington, D.C.; five service paths between New York and Boston; two service paths between Boston and Washington, D.C.; and a single route between each of the Philadelphia-Boston and Philadelphia-Washington, D.C., city pairs.

A \$375 million investment would be required to purchase the fleet of thirty-two 150-passenger STOL aircraft and supporting equipment needed in the Northeast Corridor. The selected STOL system provides 340 flights per day over 13 routes, and attracts an average of 33,152 daily passengers.

A weighted average fare of 7.46 cents per mile (higher than STOL system fare levels in either the California Corridor or Midwest Triangle) produced an estimated annual profit of \$25 million.

Table 14. Selected STOL System Service Requirements, Midwest Triangle

City Pair	STOL Service Path	Block Distance (st mi)	Block Time (hr/min)	Fare (\$)	Service Frequency (round trips per day)	Demand (daily person trips)	Percent of Total Intercity Demand	Revenue (\$/day)	Operating Costs (\$/day)
(1)	(2)								(3)
CHI-DET	CHI 1-D 1	240	0:44	16.73	19	3770	46.5	58,396	50,510
	CHI 1-D 1	217	0:41		8	1570	19.4		
CHI-CLV	CHI 1-C1	307	0:51	18.87	11	2150	53.8	37,581	32,458
(1) CITY		(2) PORT		(3) Port-related IOC = \$246.77 per departure included in operating costs					
Chicago	CHI		Meigs Field	CHI 1					
Detroit	DET		Detroit City	D1					
Cleveland	CLV		Mettetal	D2					
			Burke Lakefront	C1					

Table 15. Selected STOL System STOLport Requirements, Midwest Triangle

Port City	Annual Passengers	Annual Departures	Capital Costs (\$000)		Physical Change			
			Airfield	Terminal	Site Acq.	New Field	New Term.	Field Aug.
TOTAL			582	4,637				
CHICAGO	<u>2,161,221</u>	<u>11,083</u>	<u>72</u>	<u>2,298</u>				
Meigs Field	2,161,221	11,083	72	2,298			X	X
CLEVELAND	<u>785,258</u>	<u>4,027</u>	<u>0</u>	<u>846</u>				
Burke Lakefront	785,258	4,027	0	846			X	
DETROIT	<u>1,375,963</u>	<u>7,056</u>	<u>510</u>	<u>1,493</u>				
Detroit City	802,474	4,115	126	864			X	X
Mettetal	573,488	2,941	384	629			X	X

Data describing the service path and the operational and economic characteristics of the selected STOL system are presented in Tables 16 and 17. The STOL-induced port development costs totaled \$38 million. The absence of any airfield construction costs for the Logan Field STOLport (Table 17) derives from the announced intention of that port authority to not differentially charge for the use of STOL facilities (i. e., STOL and CTOL aircraft will not have different landing fee structures).

Table 16. Selected STOL System Service Characteristics, Northeast Corridor

City Pair	STOL Service Path	Block Distance (st mi)	Block Time (hr/min)	Fare (\$)	Service Frequency (round trips per day)	Demand, (daily person trips)	Percent of Total Intercity Demand	Revenue (\$/day)	Operating Costs (\$/day)
(1)	(2)								(3)
NY-DC				16.23	73	14,270	46.6	214,519	185,914
	NY1-DC1	195	0:38		21	4,110	13.4		
	NY2-DC1	212	0:40		24	4,658	15.2		
	NY3-DC1	221	0:41		12	2,284	7.5		
	NY1-DC2	207	0:40		16	3,218	10.5		
NY-BOS				15.45	53	10,254	46.1	146,688	127,227
	NY1-B1	191	0:38		13	2,472	11.1		
	NY2-B1	177	0:36		8	1,600	7.2		
	NY3-B1	165	0:35		7	1,250	5.6		
	NY1-B2	183	0:37		16	3,192	14.4		
	NY2-B2	168	0:35		9	1,740	7.8		
BOS-DC				21.09	24	4,620	90.2	90,229	77,921
	B1-DC1	386	1:00		11	2,106	41.1		
	B2-DC1	378	0:59		13	2,514	49.1		
PH-BOS				17.70	13	2,602	73.6	42,647	36,913
	PH1-BOS1	260	0:46		13	2,602	73.6		
PH-DC				13.96	7	1,406	7.1	18,180	15,795
	PH1-DC1	126	0:31		7	1,406	7.1		
(1) CITY	(2) PORT	(3) Port Related IOC = \$259.57 per departure included in operating costs							
New York	NY	Secaucus			NY1				
		Mitchell			NY2				
		Westchester			NY3				
Philadelphia	PH	No. Philadelphia			PH1				
Boston	BOS	Logan International			B1				
		Bedford			B2				
Washington, D.C.	DC	College Park			DC1				
		Prince Georges			DC2				

Table 17. Selected STOL System STOLport Requirements,

Port City	Annual Passengers	Annual Departures	Capital Costs (\$000)		Physical Change			
			Airfield	Terminal	Site Acq.	New Field	New Term.	Field Aug.
TOTAL			10,636	26,860				
NEW YORK	8,952,086	45,908	9,818	10,731				
Secaucus	4,742,251	24,319	9,768	5,231	X	X	X	
Mitchell	2,919,331	14,971	50	3,076			X	
Westchester	1,290,503	6,618	0	1,364			X	
WASHINGTON, D.C.	7,408,462	37,992	768	7,842				
College Pk.	5,233,794	31,968	384	6,597			X	X
Prince Georges	1,174,668	6,024	384	1,245			X	X
BOSTON	6,379,018	32,713	50	5,746				
Logan Int	3,661,626	18,778	0	3,878	X	X	X	
Bedford	2,717,391	13,935	50	2,858			X	
PHILADELPHIA	1,463,003	7,503	0	1,541				
North Phila.	1,463,003	7,503	0	1,541			X	

2. CTOL SYSTEM INFLUENCE ON STOL POTENTIAL

As was discussed in Section IV. A. 2, STOL service in the Northeast Corridor and Midwest Triangle exhibited a higher patronage than did CTOL without STOL competition. In the California Corridor the reverse was true. This contrast in STOL patronage potential is in large measure attributable to the type of service provided by the CTOL mode. An evaluation of CTOL service in each of the three arenas indicates that CTOL service in the California Corridor is superior, both in time and fare, to short haul CTOL operations within the Midwest Triangle and the Northeast Corridor. Figure-32 shows that CTOL service between the California Corridor city pairs enjoy about a 50-mph advantage in block speed over CTOL service on the Midwest Triangle and Northeast Corridor routes. These differences in block speed, based on current schedules, reflect the higher level of terminal area congestion prevalent in the Midwest and Northeast.

The variation in CTOL fares between the arenas, as illustrated in Figure 33, presents an even more striking contrast. Different fare-setting criteria, intrastate vs. interstate, and higher operating costs in the Midwest Triangle and Northeast Corridor due in part to terminal area congestion account for this fare differential.

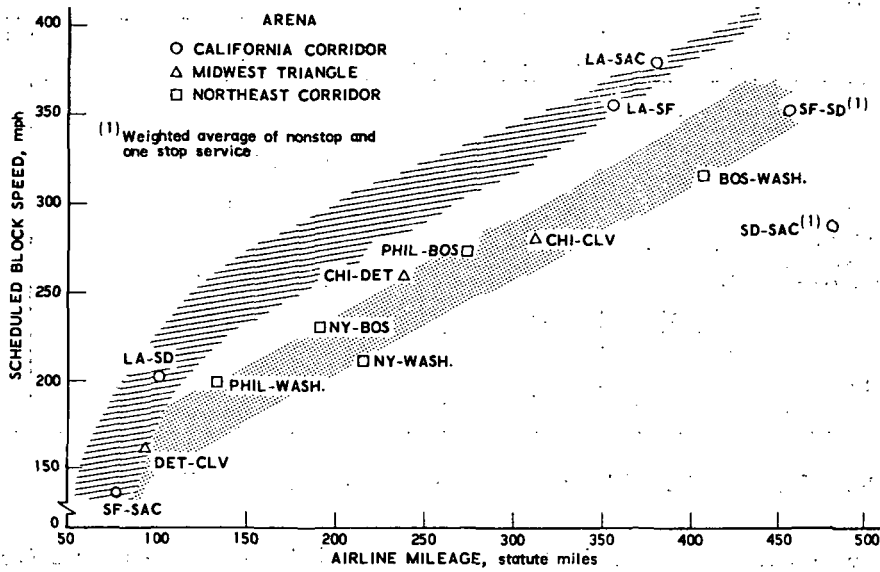

Figure 32. CTOL Block Speed Comparison

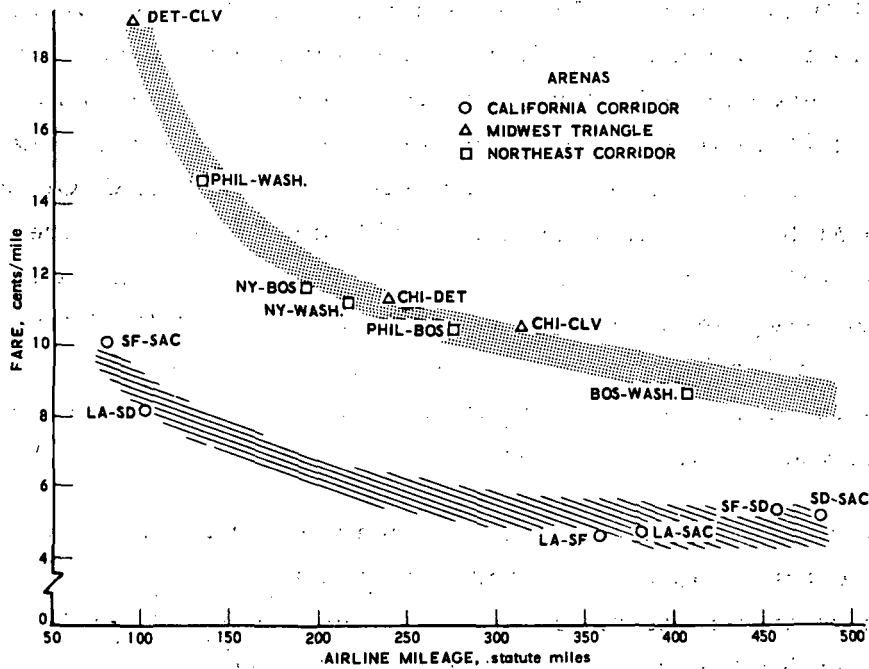

Figure 33. CTOL Fare Comparisons

The CTOL block speed and fare characteristics, Figures 32 and 33, are compared in Figure 34 to those of the selected STOL system for each city pair examined. This comparison at least partially explains why the STOL system appears relatively more attractive in the Midwest Triangle and Northeast Corridor than in the California Corridor. These differences are reiterated in Table 18, which lists the selected STOL system fares for each city pair, together with those of the primary common carriers (CTOL in all arenas plus high-speed rail in the Northeast Corridor). As shown in Section VI. B. 3, STOL can make its most significant contribution to the transportation system in arenas where congestion appears to restrict efficient CTOL service.

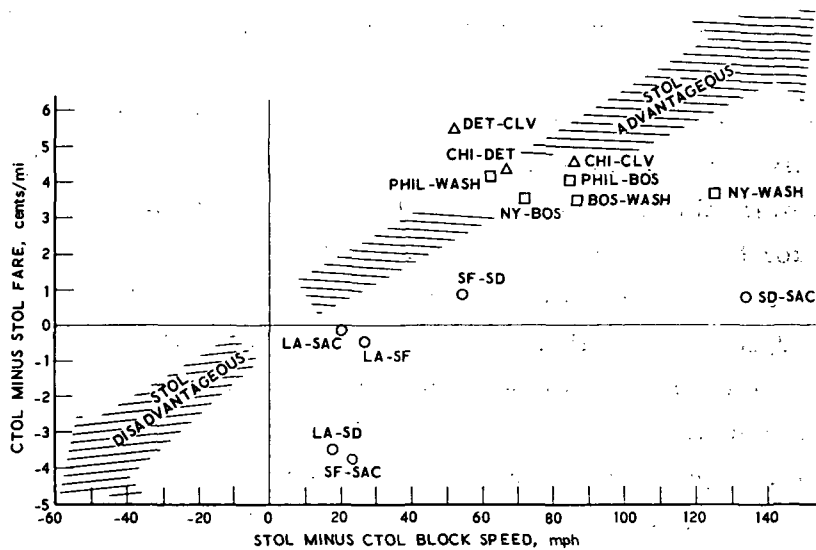

Figure 34. STOL and CTOL Comparisons

Table 18. Selected STOL System Fare Comparison

Arena	City Pair	One Way Fare (1970 Dollars)		
		STOL	CTOL	Rail ⁽¹⁾
California Corridor	Los Angeles-San Francisco	18.28	16.50	-
	San Francisco-San Diego	20.69	24.50	-
	Los Angeles-Sacramento	18.63	18.00	-
Midwest Triangle	Chicago-Detroit	16.73	27.00	-
	Chicago-Cleveland	18.87	33.00	-
Northeast Corridor	New York-Washington, D.C.	16.23	24.10	15.95
	New York-Boston	15.45	22.25	15.95
	Washington, D.C.-Boston	21.09	35.23	30.20
	Boston-Philadelphia	17.70	28.74	21.92
	Washington, D.C.-Philadelphia	13.96	19.47	10.20

(1) Interim High-Speed Rail-Option 1 (Ref. 5); Aerospace estimated fares.

The New York-Washington, D.C. air fare structure was examined in order to identify those factors leading to lower STOL fares (relative to CTOL) and to approximate the individual contributions of each factor. The derived one-way fare for the selected STOL system (150-passenger vehicle, 8-percent ROI) between New York and Washington, D.C., was \$16.23. The CTOL fare was established at \$24.10, also in 1970 dollars. This reduction of \$7.87 was made possible by a number of operational changes which more than compensated for the increased DOC associated with replacing a DC9-30 CTOL with a 150-passenger Augmentor Wing aircraft. The data presented in Figure 34 not only define the factors contributing to the CTOL-to-STOL fare decrease but also approximate the division of each contribution by component (i.e., DOC, IOC, profits required to achieve a given ROI, and an 8-percent transportation tax).

The columns of Figure 35 illustrate the contributions of the factors that cause the reduction from the nominal CTOL fare (\$24.10) to the nominal STOL fare (\$16.23). The first increment accounts for the increase in DOCs due to the replacement of a DC9-30 with a 150-passenger STOL, which resulted in a fare increase to \$29.38. Block distance was decreased 21 miles reflecting

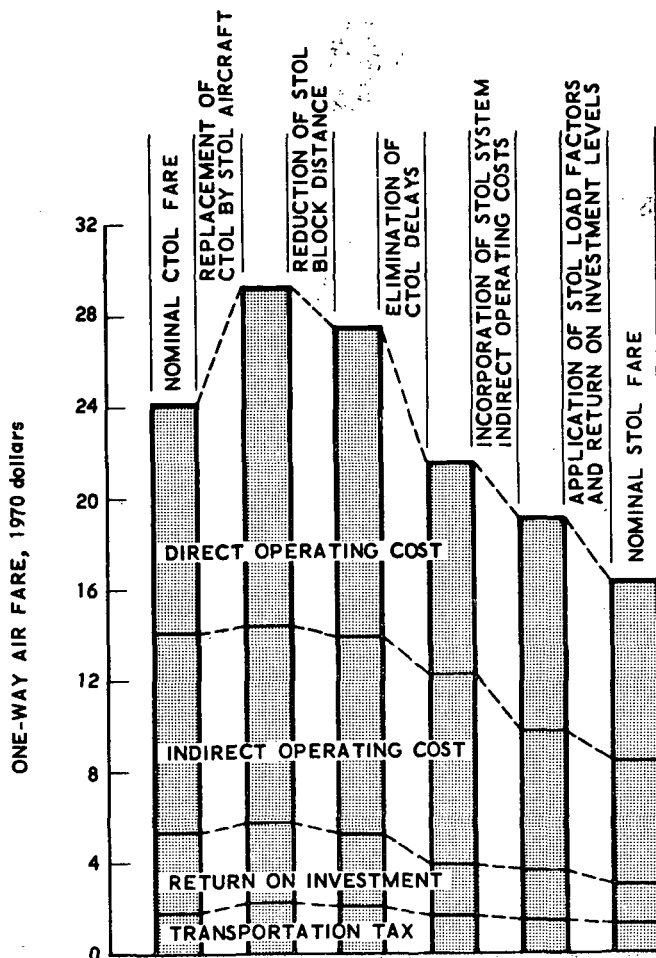

Figure 35. CTOL and STOL Fare Comparisons, New York-Washington City Pair

STOL operations between Secaucus and College Park (207 miles) compared to a CTOL block distance of 228 miles (La Guardia to Washington National). This lowered the fare to \$27.38. The elimination of an 18-minute, congestion-caused component of the scheduled CTOL block time, made possible by STOL's ability to utilize uncongested airfields and dedicated airspace, resulted in an additional fare reduction of \$5.88 (to \$21.50). This component alone is sufficient to compensate for the higher DOCs resulting from the replacement of CTOL by STOL aircraft. The lower port-related IOCs, reflecting the use of STOLports optimized to handle high-density short haul service exclusively, produced an even lower fare of \$18.98. Finally, since the New York-Washington, D.C., CTOL system load factor and ROI values were not readily available, the contribution of these elements was assumed to be equivalent to the remaining difference between the STOL and CTOL fares. Inherent in the CTOL ROI element is the greater fleet investment required for backup aircraft to support an air shuttle operation.

3. STOL IMPACT ON ALTERNATIVE MODES

The analysis employed in this study was based on a forecast of total 1980 intercity origin and destination demand, which was then distributed to the competing modes in accordance with their relative attributes [Volume II, Appendix C-1 (Ref. 3)]. Since the total demand was fixed (i. e., no induced demand), the patronage attracted to a new STOL service was totally at the expense of the alternative transportation modes operating between a given city pair (be they car, CTOL, bus, or possibly rail). To derive this information, the 1980 intercity transportation systems were simulated both with and without STOL operations, and the resulting modal splits were determined. The STOL system simulated in this analysis was characterized as defined in Section VI. B. 1 and included only those city pairs that were able to produce an 8-percent ROI when using 150-passenger vehicles. The percentage of total origin and destination demand attracted to STOL, the increase in origin and

destination air travelers--STOL plus CTOL--resulting from the implementation of STOL service, and the resulting distribution of origin and destination demand between the two air modes are summarized in Table 19.

For the economically viable city pairs in the California Corridor, Table 20 lists the 1980 origin and destination travel demand by mode both with and without STOL service, the net and percentage change in demand resulting from STOL service implementation, and the percent of modal split. An examination of the data reveals that STOL service between San Francisco and San Diego had a large impact on the competing modes. This STOL impact can be attributed to a greater reduction in air block time resulting from implementing a nonstop STOL service. The San Diego-San Francisco block times for CTOL were weighted by a mix of nonstop and one-stop flights. The STOL system also had relatively lower fares (Table 18).

Table 19. Selected STOL System Potential, 150-Passenger Vehicle, ROI = 8 Percent

Arena ⁽¹⁾	Percent Modal Split	Daily Person Trips	Increase in Air Demand Due to STOL Implementation (%)	Portion of Air Demand Using STOL (%)
California Corridor	22	11,400	6.5	49.4
Midwest Triangle	49	5,920	65.7	97.1
Northeast Corridor	41	33,200	87.8	95.5

⁽¹⁾ Includes only selected STOL system city pairs

Table 20. STOL Service Impact, California Corridor

Los Angeles - San Francisco						
Mode	1980 Travel Demand				Modal Split, %	
	Daily Person Trips			Percent Changes	Without STOL	With STOL
	W/O STOL	With STOL	Net Change			
Car	20,631	20,186	-445	-2.2	54	53
CTOL	16,340	10,563	-5,777	-35.4	43	28
STOL	-	6,302	6,302	-	-	17
Bus	631	567	-64	-10.1	2	1
Rail	178	162	-16	-9.0	<1	<1
Total	37,780	37,780	0	0	100	100
Total Air	16,340	16,865	525	3.2	43	45

San Francisco - San Diego						
Mode	1980 Travel Demand				Modal Split, %	
	Daily Person Trips			Percent Changes	Without STOL	With STOL
	W/O STOL	With STOL	Net Change			
Car	3,354	2,744	-610	-18.2	52	43
CTOL	2,936	158	-2,778	-94.6	46	3
STOL	-	3,434	3,434	-	-	53
Bus	118	72	-46	-39.0	2	1
Rail	-	-	-	-	-	-
Total	6,408	6,408	0	0	100	100
Total Air	2,936	3,592	656	22.3	46	56

Los Angeles - Sacramento						
Mode	1980 Travel Demand				Modal Split, %	
	Daily Person Trips			Percent Changes	Without STOL	With STOL
	W/O STOL	With STOL	Net Change			
Car	4,344	4,144	-200	-4.6	63	60
CTOL	2,378	938	-1,440	-60.6	35	14
STOL	-	1,664	1,664	-	-	24
Bus	132	108	-24	-18.2	2	2
Rail	-	-	-	-	-	-
Total	6,854	6,854	0	0	100	100
Total Air	2,378	2,602	224	9.4	35	38

The similarity of the two economically viable city pairs in the Midwest Triangle, Chicago-Detroit and Chicago-Cleveland, resulted in modal splits with only the subtle differences shown in Table 21. The longer distance between Chicago and Cleveland, as compared to the Chicago-Detroit mileage, accentuated the air mode time advantage and resulted in a higher percentage of air travelers between Chicago and Cleveland than between Chicago and Detroit. The Midwest Triangle STOL system with its low fares, good service frequency, and advantageous port locations provided a substantial improvement in the transportation service available within that arena. As a result, the STOL system captures virtually all of the CTOL travelers, as well as a significant number of automobile travelers.

As quantified by the modal split results presented in Table 22, the selected STOL system operating in the Northeast Corridor captured virtually all of the CTOL patronage. The proximity of Philadelphia to Washington, D.C., resulted in a very high car modal split of 75 percent. Conversely the longer distance and time requirement on ground modes passing through or bypassing the New York metropolitan region resulted in very high air modal splits between Philadelphia and Washington to Boston. STOL service between the latter city pair would attract almost all origin and destination travelers, producing a modal split of 91 percent. STOL service between the New York-Washington, D.C., and the New York-Boston city pairs (where intercity distances fall between the extremes of the three city pairs previously discussed) each attracted slightly less than one-half of all the origin and destination travelers.

Unlike travelers in the California Corridor and Midwest Triangle arenas, Northeast Corridor travelers have access to a relatively high-speed, high-frequency intercity rail passenger service which, prior to the introduction of STOL service, attracted as much as 25 percent of the intercity (New-York-Washington) demand. The impact of STOL service on rail, as well as on the other modes, is dependent on the intercity distance. Since air service becomes more competitive with alternative ground modes as intercity

Table 21. STOL Service Impact, Midwest Triangle

Chicago-Detroit						
Mode	1980 Travel Demand				Modal Split, %	
	Daily Person Trips			Percent Changes	Without STOL	With STOL
	W/O STOL	With STOL	Net Change			
Car	5,254	4,032	-1,222	-23.3	65	50
CTOL	2,338	118	-2,220	-95.0	29	1
STOL	-	3,770	3,770	-	-	47
Bus	414	156	-258	-62.3	5	2
Rail	94	24	-70	-74.5	1	<1
Total	8,100	8,100	0	0	100	100
Total Air	2,338	3,888	1,550	66.3	29	48

Chicago-Cleveland						
Mode	1980 Travel Demand				Modal Split, %	
	Daily Person Trips			Percent Changes	Without STOL	With STOL
	W/O STOL	With STOL	Net Change			
Car	2,466	1,724	-742	-30.1	62	43
CTOL	1,342	60	-1,282	-95.5	33	1
STOL	-	2,150	2,150	-	-	54
Bus	126	44	-82	-65.1	3	1
Rail	66	22	-44	-66.7	2	<1
Total	4,000	4,000	0	0	100	100
Total Air	1,342	2,210	868	64.7	33	55

Table 22. STOL Service Impact, Northeast Corridor

New York - Washington						
Mode	1980 Travel Demand				Modal Split, %	
	Daily Person Trips			Percent Changes	Without STOL	With STOL
	W/O STOL	With STOL	Net Change			
Car	14,176	11,054	-3,122	-22.0	46	36
CTOL	6,302	660	-5,642	-89.5	21	2
STOL	-	14,274	14,274	-	-	-
Bus	2,456	1,348	-1,108	-45.1	8	4
Rail	7,630	3,228	-4,402	-57.7	25	-
Total	30,564	30,564	0	0	100	100
Total Air	6,302	14,934	8,632	137.0	21	49

New York - Boston						
Mode	1980 Travel Demand				Modal Split, %	
	Daily Person Trips			Percent Changes	Without STOL	With STOL
	W/O STOL	With STOL	Net Change			
Car	12,400	9,802	-2,598	-20.9	56	44
CTOL	6,298	658	-5,640	-89.6	28	3
STOL	-	10,256	10,256	-	-	46
Bus	1,788	876	-912	-51.0	8	4
Rail	1,752	646	-1,106	-63.1	8	3
Total	22,238	22,238	0	0	100	100
Total Air	6,298	10,914	4,616	73.3	28	49

Boston - Washington						
Mode	1980 Travel Demand				Modal Split, %	
	Daily Person Trips			Percent Changes	Without STOL	With STOL
	W/O STOL	With STOL	Net Change			
Car	1,040	412	-628	-60.4	20	8
CTOL	3,680	22	-3,658	-99.4	72	1
STOL	-	4,666	4,666	-	-	91
Bus	76	6	-70	-92.1	2	<1
Rail	328	20	-308	-93.9	6	<1
Total	5,124	5,124	0	0	100	100
Total Air	3,680	4,688	1,008	27.4	72	92

Table 22. STOL Service Impact, Northeast Corridor (Cont)

Philadelphia - Boston						
Mode	1980 Travel Demand				Modal Split, %	
	Daily Person Trips			Percent Changes	Without STOL	With STOL
	W/O STOL	With STOL	Net Change			
Car	1,342	814	-528	-39.3	38	23
CTOL	1,696	26	-1,670	-98.5	48	<1
STOL	-	2,602	2,602	-	-	74
Bus	166	38	128	-77.1	5	1
Rail	330	54	276	-83.6	9	2
Total	3,534	3,534	0	0	100	100
Total Air	1,696	2,628	932	55.0	48	74

Philadelphia - Washington						
Mode	1980 Travel Demand				Modal Split, %	
	Daily Person Trips			Percent Changes	Without STOL	With STOL
	W/O STOL	With STOL	Net Change			
Car	14,946	14,532	-414	-2.8	76	74
CTOL	528	188	-340	-64.4	3	1
STOL	-	1,406	1,406	-	-	7
Bus	892	806	-86	-9.6	4	4
Rail	3,352	2,786	-566	-16.9	17	14
Total	19,718	19,718	0	0	100	100
Total Air	528	1,594	1,066	201.9	3	8

distance increases, the impact of STOL service would be greater at longer distances. This is borne out by the trend lines of Figure 36 which identifies the degradation of patronage on each individual mode (relative to the "no STOL" levels) as a function of intercity distance. The degree of STOL impact is also directly related to the similarity of a given mode's system characteristics to those of STOL. Thus CTOL, a high-speed common carrier appealing to the same group of travelers as STOL, is the recipient of the greatest impact. Private car--a relatively slow, low-cost mode--is least affected, with the two common carrier ground modes, rail and bus, falling between the other two.

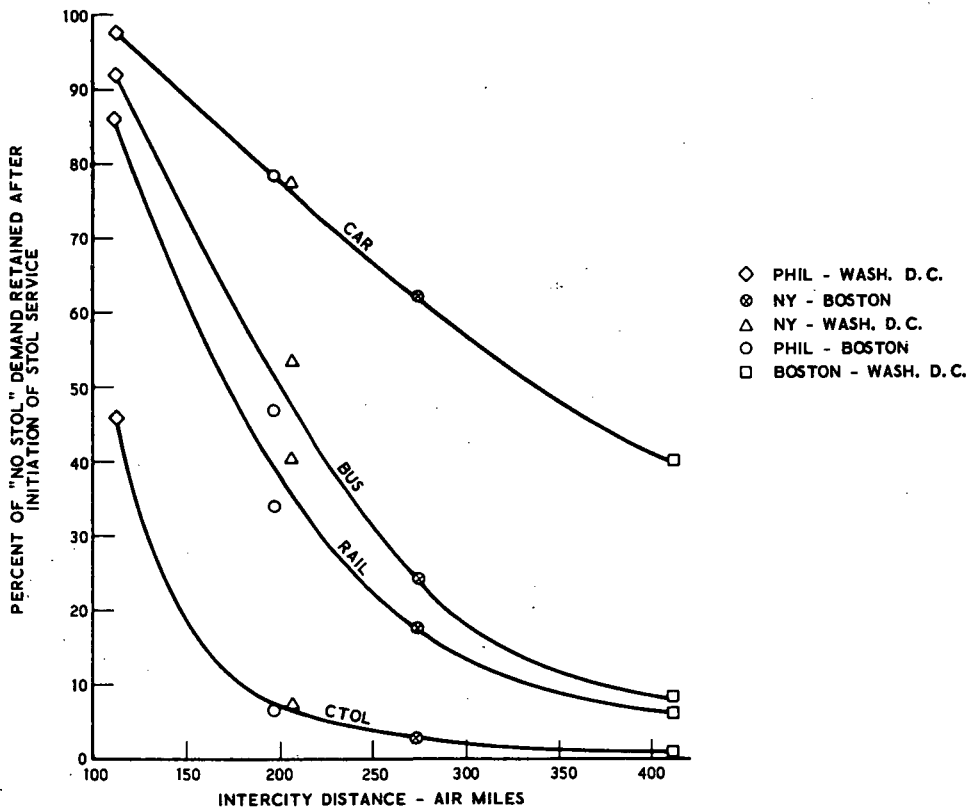

Figure 36. STOL Impact on Other Northeast Corridor Modes

C. ENVIRONMENTAL RESULTS

1. NOISE IMPACT

a. Single-Event Noise Contours

The noise characteristics of the STOL vehicles were examined on a single-event basis in order to indicate the extent of noise impact that could be anticipated at dedicated STOLports. Figure 37 contains contours of constant effective perceived noise (EPN) levels for the 150-passenger Augmentor Wing STOL aircraft, using a 7-degree approach path and a 14-degree departure path. Included in these results are the effects of added ground and spatial attenuation peculiar to Augmentor Wing powered-lift aircraft. The small size of these contours is striking. The 100-EPNdB contour would, for example, be essentially contained within the confines of a 2000-foot x 200-foot runway. This may be compared with the Douglas DC-10, wide-body CTOL transport's 100-EPNdB contour whose approximate overall length is 27,000 feet and

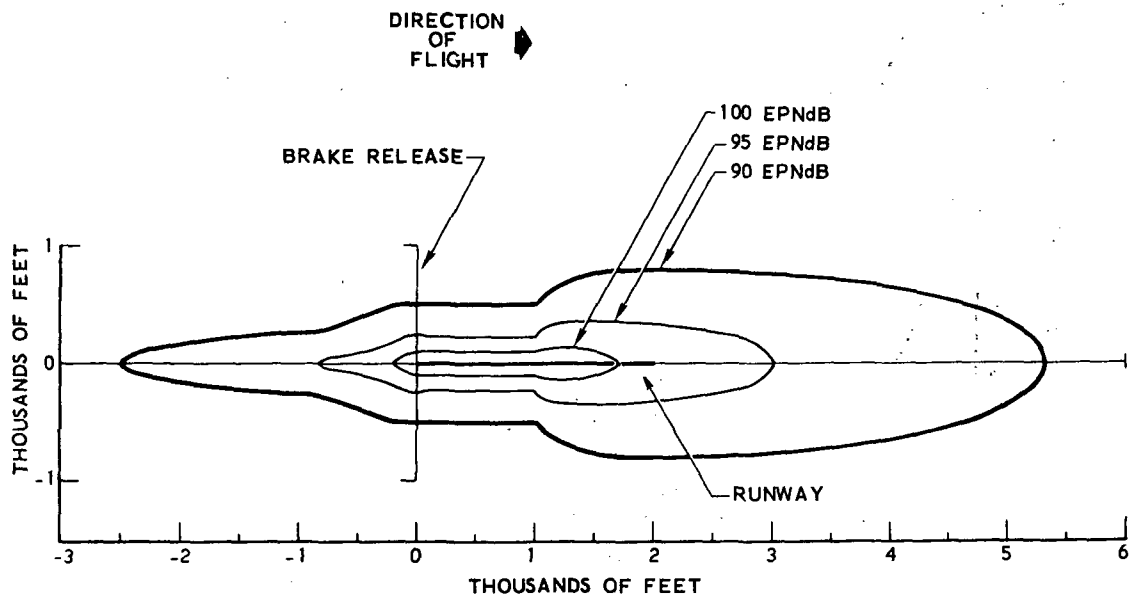

Figure 37. Effective Perceived Noise Level Contours

maximum width is 3000 feet (Ref. 24). The reference also indicates that current 4-engine, narrow-body turbofan CTOL transport aircraft produce a 100-EPNdB contour that is 90,000 feet long and 7000 feet wide.

The 100-EPNdB contour corresponds to NEF = 30 for 63 landing and 63 takeoff operations per day (a total of 126 aircraft movements) of unmixed traffic (one aircraft type). The impact of this number of STOL aircraft operations at a STOLport is clearly negligible. On the other hand, the impact at a CTOLport of the same number of wide-body CTOL aircraft operations is much more significant in terms of the length of the contour (over five miles) relative to the length of most ports (about two to three miles). Narrow-body CTOL aircraft produce a more severe impact.

b. Operational Scenarios

Eighteen STOLports are included in the selected STOL system: six in the California Corridor, four in the Midwest Triangle, and eight in the Northeast Corridor. Noise studies were performed at 16 of these ports, using the 150-passenger STOL aircraft mixed with appropriate numbers of general aviation aircraft at all nondedicated STOLports. The objective was to determine the incremental impact of STOL aircraft on the overall noise environment in the airport and surrounding areas. Numbers of STOL aircraft operations at each port were determined from the economic viability studies (Section VI.B.1).

The level of anticipated 1980 general aircraft operations at each port was derived from a 1971 data base and compared with the general aviation PANCAP* for each airport. The smaller of the two numbers was selected.

* PANCAP (Practical Annual Capacity) is a quantity indicative of the number of operations that may be handled on each runway at the airport without creating unacceptable delays in the terminal airspace (Ref. 25). While it is recognized that operational levels at some airports do exceed the calculated PANCAP, this is usually caused by local conditions which violate the PANCAP basis of calculation.

Thus, to provide estimates for each port that would be consistent with existing facilities, it was assumed that general aviation traffic would not exceed PANCAP in any case.

STOL operations were added to CTOL operations at all single-runway airports. At two-runway airports, STOL operations were conducted on one runway (normally the localizer runway) while CTOL operations were conducted on both runways. Three cases were evaluated at each port with general aviation operations: one with STOL traffic only, one with general aviation traffic only, and one with both STOL and general aviation traffic. The mix of general aviation operations was assumed to be 25-percent twin-engine and 75 percent single-engine aircraft.

General aviation trajectories were determined for representative twin-engine aircraft (Cessna 310) and high-performance single-engine aircraft (Beech Bonanza). Table 23 lists the conditions considered and the approach and departure path angles used. In all cases, straight-in approaches and departures were assumed.

STOL trajectories were computed for the curved approach and departure paths at several California ports. This type of path turned out to be unnecessary from the noise standpoint, however, because STOL noise proved to be confined to the region within or immediately adjacent to the airport.

Table 23. General Aviation Aircraft Flight Characteristics

Condition	Aircraft Type	
	Single Engine	Twin Engine
Initial Rate of Climb	1200 fpm	1500 fpm
Initial Climb Speed	91 knots	113 knots
Climb Path Angle	7.5 deg	7.5 deg
Rate of Descent	500 fpm	635 fpm
Approach Speed	70 knots	90 knots
Approach Path Angle	4 deg	4 deg

Noise data on the single- and twin-engine general aviation aircraft currently using many of the airports selected as STOLports in the present study was obtained from Reference 26. A sample of single- and twin-engine aircraft noise data is shown in Figure 38. The data are based on measurements made on a number of popular general aviation aircraft models.

c. California Corridor Noise Results

A result typical of the noise analyses performed is shown in Figure 39 for the Fullerton airport. Figure 39(a) is a computer plot of land zones with

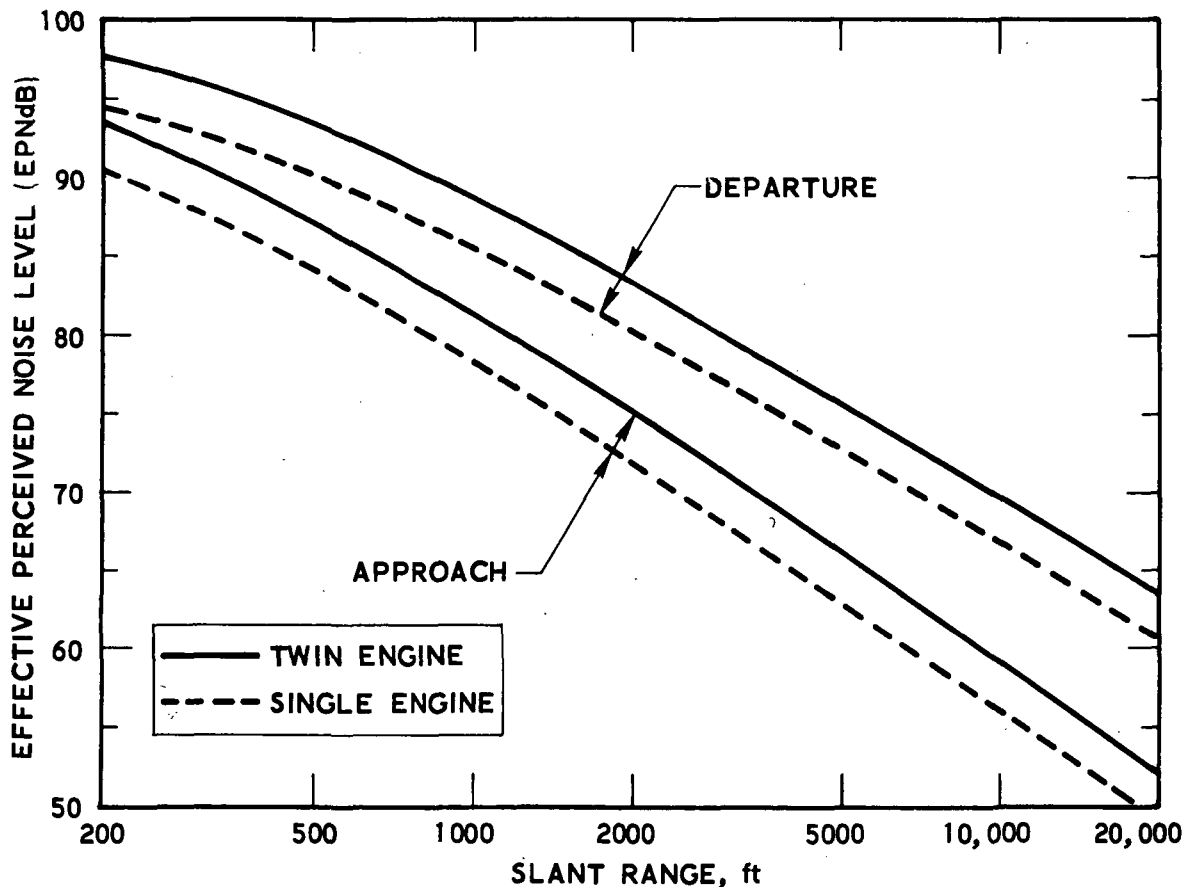
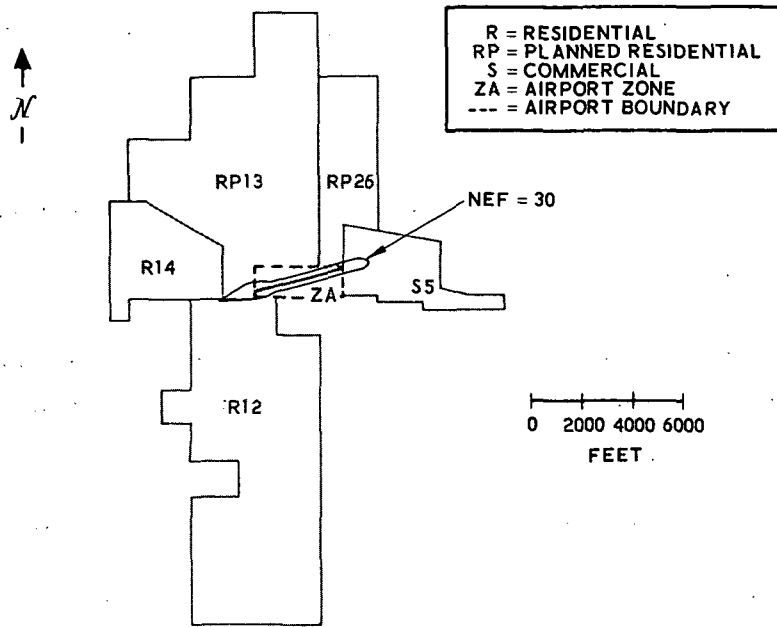
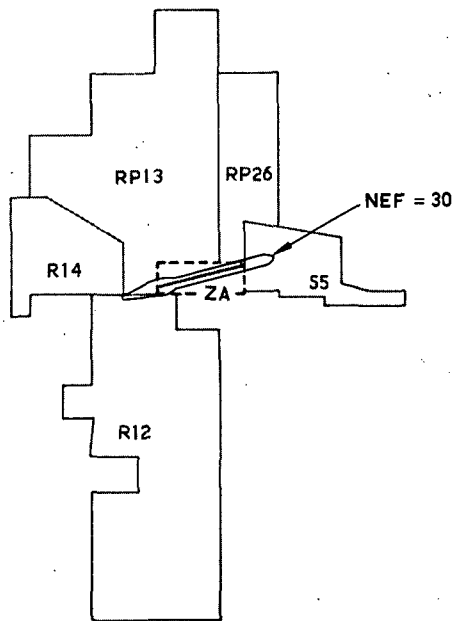

Figure 38. General Aviation Aircraft Noise Characteristics



(a) 0 STOL, 600 CTOL Daily Operations



(b) 28 STOL, 600 CTOL Daily Operations

Figure 39. Fullerton Airport Noise Analysis

the NEF = 30 contour resulting from 600 general aviation operations per day, superimposed. Some residential land parcels are impacted at this port by general aviation traffic. Figure 39(b) depicts the same location with the addition of 28 STOL operations per day. The effect of the STOL operations when they are combined with CTOL is imperceptible. Table 24 summarizes the results for all six California Corridor STOLports. Note that only five per cent (just under one and one-half acres) of the noise-impacted area outside the Fullerton Airport boundary may be attributed to the addition of STOL flights. Similar results are indicated for Palo Alto, Montgomery, and Executive. The largest noise impact increment due to STOL flights is at Palo Alto, but this occurs on open undeveloped land surrounding the airport near San Francisco Bay.

The reason for the minimal STOL impact may be better understood by examining the results (Table 24) for the two dedicated STOLports, Patton

Table 24. STOLport Operations, California Corridor

AIRPORT	RUNWAY LAYOUTS	OPERATIONS			IMPACTED AREA (ACRES)		
		GENERAL AVIATION (per runway)		1980 STOL	TOTAL WITHIN NEF=30	OUTSIDE AIRPORT, CTOL + STOL	OUTSIDE INCREMENT DUE TO STOL
		PANCAP	1980 PROJ				
FULLERTON	/	600	770	28	72.4	28.4	1.5
PATTON	/	-	0	54	2.4	0	0
INDIA BASIN	\	-	0	66	3.0	0	0
PALO ALTO	\	600	980	34	72.9	31.4	2.1
MONTGOMERY	//	525	690	36	158.3	46.0	2.0
SACRAMENTO	X	500	560	18	130.4	1.2	0.1

and India Basin. The total area contained within the NEF = 30 contours at each of these ports is less than three acres, and the noise contours remain within the airport boundaries at both ports, even though the number of STOL aircraft operations exceeds that at the general aviation airports. Thus, the noise contribution of general aviation aircraft operations far exceeds that of the STOL aircraft operations, both because basic STOL noise levels are low and STOL vehicles approach and depart the airports along steeply inclined paths. The total noise exposure due to the combined systems is, therefore, mainly attributable to general aviation.

d. Midwest Triangle Noise Results

Table 25 presents the results derived for the four Midwest Triangle ports. This arena has no dedicated STOLports. The STOL contribution to off-airport noise impact is greatest at Meigs, but the impacted areas are beachfront or park properties, with no residential areas involved. Even at Mettetal, where both runway thresholds are almost coincident with the airport boundary, the STOL system accounts for less than four percent of the adverse off-airport noise impact.

Table 25. STOLport Operations, Midwest Triangle

AIRPORT	RUNWAY LAYOUTS	OPERATIONS			IMPACTED AREA (ACRES)		
		GENERAL AVIATION (per runway)		1980 STOL	TOTAL WITHIN NEF = 30	OUTSIDE AIRPORT, CTOL + STOL	OUTSIDE INCREMENT DUE TO STOL
		PANCAP	1980 PROJ				
MEIGS		600	440	62	52.9	12.2	1.5
BURKE	≡	525	195	22	129.6	0.6	0.2
DETROIT CITY	>	500	580	22	140.3	15.8	0.2
METTETAL		600	740	16	71.2	34.7	0.9

e. Northeast Corridor Noise Results

The Northeast Corridor STOL system uses eight ports, of which only Secaucus is a dedicated STOLport. It is the only arena of the three studied in which a CTOL jetport was chosen as a site for a STOL runway. Logan Airport, near the Boston CBD, is planning such a runway on a new land fill location, and it may be amenable to almost completely segregated air and ground operations. A noise analysis was not made at Logan because its operations and its noise environment are dominated by large airline jet aircraft. Mitchell Field, on Long Island, was not analyzed because this former Air Force Base contains many thousands of acres of land for which no specific use has been identified. Thus, unless major land use changes were implemented, it would not present a noise problem if the centrally located runways were used for quiet STOL operations.

The results for the Northeast Corridor, shown in Table 26, once again indicate a minimal impact from quiet STOL operations. Of particular interest are the College Park and Secaucus STOLports, supporting the largest and second largest number of STOL operations in any of the arenas studied. At College Park, a small general aviation facility, STOL operations exceed projected general aviation movements. Even so, an increment of less than one acre of impacted land outside the airport boundary can be attributed to the STOL system, and the total area affected by noise is seen to be minimal. At Secaucus (Figure 40), a proposed facility under study by the New Jersey DOT, the NEF = 30 contour area is completely contained within the boundaries of the 200-acre port. In fact, it represents only three percent of the port's area. At Westchester County Airport, the noise impact on the surrounding community is essentially zero when only quiet STOLcraft are operated on airline routes into the airport.

Table 26. STOLport Operations, Northeast Corridor

AIRPORT	RUNWAY LAYOUTS	OPERATIONS			IMPACTED AREA (ACRES)		
		GENERAL AVIATION (per runway)		1980 STOL	TOTAL WITHIN NEF=30	OUTSIDE AIRPORT CTOL + STOL	OUTSIDE INCREMENT DUE TO STOL
		PANCAP	1980 PROJ				
SECAUCUS		-	0	134	6.0	0	0
MITCHELL		-	0	82	-	-	-
WESTCHESTER		500	750	36	143.6	3.3	0
COLLEGE PK		600	130	176	22.9	1.5	0.7
P.G. AIRPARK		600	235	34	25.1	0.4	0.1
LOGAN		-	-	104	-	-	-
BEDFORD		500	810	76	139.4	5.8	0.5
NO. PHILA.		500	470	42	102.4	16.5	0.2

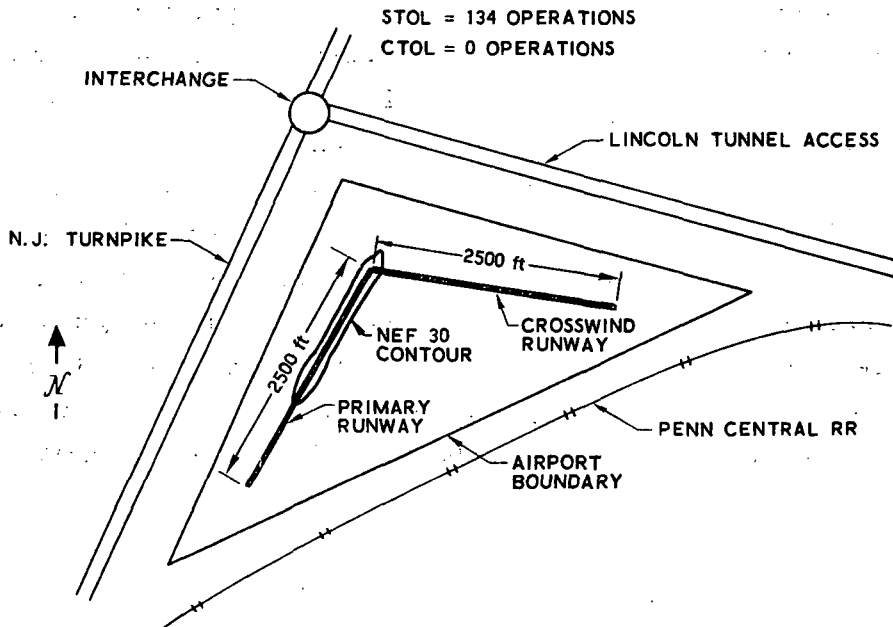

Figure 40. Secaucus STOLport Noise Analysis

f. Noise Tradeoff Analysis

An analysis was made of the effects of varying aircraft noise levels, flight path conditions, and numbers of operations on the area within an NEF = 30 contour. Baseline aircraft noise levels were varied from 95 EPNdB at 500 feet below the aircraft (representative of anticipated Augmentor Wing aircraft technology) to 110 EPNdB at 500 feet below the aircraft (representative of current DC-10/L-1011 aircraft technology). Daily operations were varied from a low of 20 landings and takeoffs to 200 landings and takeoffs of a single aircraft type flying the prescribed trajectory. Flight paths were varied from one typical of an Augmentor Wing STOL to one typical of a present-day CTOL. Imbedded in the flight path variations is a field length variation, as indicated in the following tabulation:

<u>Flight Path (approach/departure)</u>	<u>FAR Field Length (ft)</u>
7°/14°	2000
5°/11°	4000
3°/8°	8000

Results for a STOL-type flight path are shown in Table 27 and indicate the effects of varying baseline noise levels and daily aircraft operations. Results for a constant level of daily operations are shown in Table 28 and indicate the effects of varying baseline noise levels and flight path parameters.

The following observations can be made from an examination of Table 27 (STOL-type flight path) and Table 28 (200 daily operations):

- For the STOL-type flight path, six combinations of noise and operational levels can be found in which the length of the noise contour is 2500 feet or less. These contours can be expected to remain within the boundaries of most existing general aviation airports. In contrast, for a level of 200 daily operations, only the STOL-type flight path produces a contour small enough to remain within the normal airport boundary.

Table 27. Noise Sensitivity to Aircraft Operations

NEF = 30
 STOL Flight Path
 (7° Approach/14° Departure)

EPNdB at 500 ft Daily Aircraft Operations	95	98	104	110	
	20	1	2	12	77
1200 x 50		1300 x 100	2200 x 300	5100 x 1000	L x W, ft
60	4	8	54	292	Area, acres
	1500 x 150	1900 x 250	4300 x 800	10100 x 2000	L x W, ft
200	16	42	240	1070	Area, acres
	2500 x 400	3900 x 700	9000 x 1800	19600 x 3900	L x W, ft

Table 28. Noise Sensitivity to Flight Path

NEF = 30
 200 Daily Aircraft Operations

EPNdB at 500 ft Flight Path	95	98	104	110	
	7°/14°	16	42	240	1070
2500 x 400		3900 x 700	9000 x 1800	19600 x 3900	L x W, ft
5°/11°	43	100	430	1750	Area, acres
	4400 x 600	6100 x 1000	13100 x 2400	27300 x 5000	L x W, ft
3°/8°	75	160	650	2600	Area, acres
	7500 x 600	9900 x 1000	20500 x 2400	42300 x 5000	L x W, ft

- The quietest of today's commercial jet aircraft (near 110 EPNdB at 500 feet below the aircraft), flying a STOL-type flight path, would produce a noise contour nearly 5 miles long and encompassing almost 2 square miles of land for 200 daily operations (approximately the number of daily operations of the major intrastate carrier at San Francisco International Airport). A more typical flight path for this aircraft type results in a contour more than 8 miles long and encompassing more than 4 square miles of land.
- Aircraft with noise levels approaching the goal set for STOL aircraft (95 EPNdB at 500 feet) but flying a CTOL-type trajectory ($3^{\circ}/8^{\circ}$) produce a noise contour at 200 daily operations which would remain within the boundary of most jetports. The same is true for an aircraft twice as noisy but flying a steeper trajectory ($5^{\circ}/11^{\circ}$).
- Use of noise abatement procedures (here approximated by the $5^{\circ}/11^{\circ}$ trajectory) results in reduction of noise contour length and area approaching a factor of two when compared with standard CTOL trajectories at 200 daily operations.

2. AIR POLLUTION IMPACT

One aspect of introducing a STOL system was its impact on air pollution in each of the three arenas studied. When the pollution characteristics developed in Section IV were merged with the before-STOL and after-STOL air traffic presented previously, the total daily emissions shown in Figures 41, 42, and 43 were obtained. For three alternative aircraft mixes, each figure shows these emissions as a function of CTOL ground time before takeoff. The aircraft labeled "current" CTOL incorporates the emission characteristics of the P&W JT8D-15 engine. Both STOL and "advanced" CTOL incorporate the emission characteristics of the Allison engine used in this study. In all cases, STOL ground time is held constant at three minutes. Aside from the obvious advantage provided by advanced engine technology in improving terminal area environments, some interesting comparisons can be drawn between arenas.

It has been shown that the California Corridor provides the most resistance to introduction of widespread STOL service. Thus, a significant emission advantage would accrue to STOL only at the higher CTOL ground times

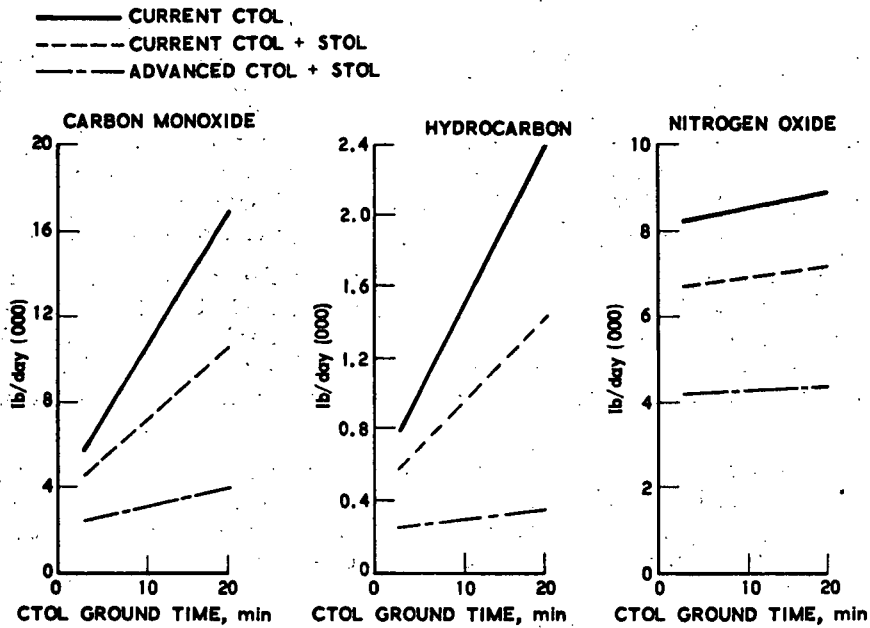

Figure 41. Aviation-Produced Emissions, California Corridor

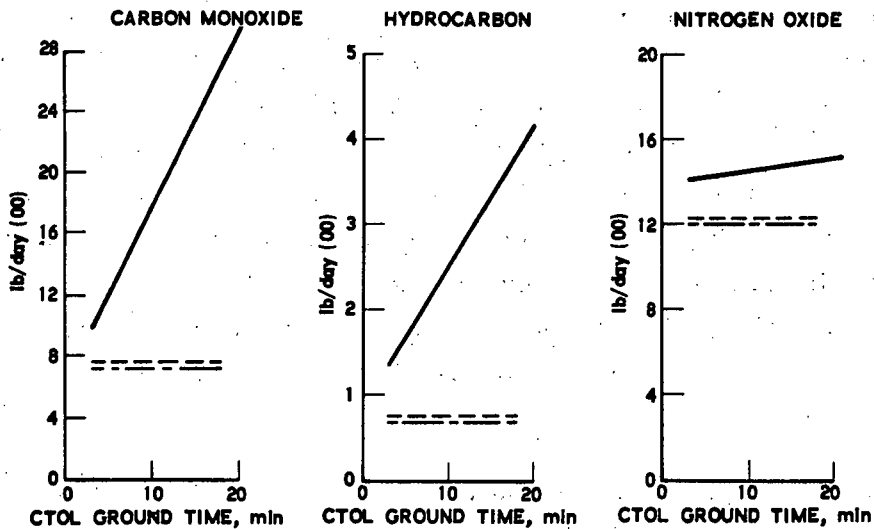

Figure 42. Aviation-Produced Emissions, Midwest Triangle

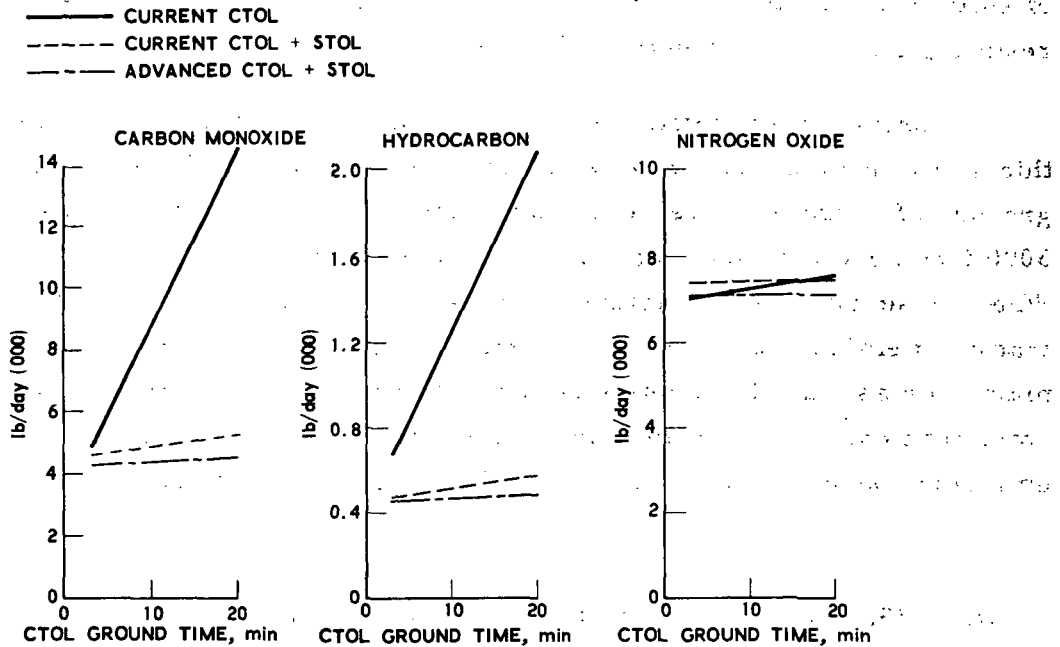

Figure 43. Aviation-Produced Emissions, Northeast Corridor

(Figure 41), but those longer times are less likely in the California Corridor than in the other arenas. On the other hand, introduction of advanced-propulsion technology to CTOL offers a large improvement over current CTOL and a significant improvement over the mix of STOL and current CTOL.

In the Midwest Triangle it was shown that STOL completely replaces CTOL service while stimulating an overall growth in air travel. The result is a significant reduction over the current spread of emission levels (Figure 42 - note difference in scale), but it shows no advantage for incorporating advanced propulsion in the CTOL aircraft.

In the Northeast Corridor it was shown that STOL creates a significant growth in air travel demand. However, the benefits of its advanced-technology engine still cause a net reduction in aviation-produced emissions, except for the NO_x constituent (Figure 43). Parallel CTOL service is still

of sufficient magnitude to provide a slight additional reduction in emissions resulting from an introduction of advanced propulsion.

A proper interpretation of results from the pollution impact portion of this study requires that they be reviewed in the context of the emission backgrounds of representative urban environments. Aircraft emissions below 3000 feet were calculated at the airports, as shown in Table 29 (Ref. 27). When these data are normalized to the area of the air terminal, the concentration of emissions around the airports is seen to be generally of the same magnitude as that of the entire region. Thus, substantial growth in aviation emissions cannot be assumed to create corresponding growth in community emission concentrations. Local weather and geography play an important

Table 29. Comparison of Aircraft Exhaust Emissions at Air Terminals

Location	Carbon Monoxide		Hydrocarbons		Nitrogen Oxides	
	Tons per Day	T/D per Sq. Mile	Tons per Day	T/D per Sq. Mile	Tons per Day	T/D per Sq. Mile
New York ^a JFK Airport	2,666 33	14.1 6.1	756 13	4.0 2.2	547 2.5	2.9 0.2
Virginia- Washington, D.C. ^b National Airport	1,586 35	15.4 15.0	361 5	3.5 2.2	175 0.6	1.7 0.3
Los Angeles Basin Los Angeles International ^c	10,137 36	8.1 9.3	2,740 14	2.2 3.7	750 2.5	0.6 0.3

*T/D = Tons per Day

^aKings and Queens Counties

^bD. C. ; Arlington County; and Alexandria City, Virginia

^cAircraft emissions based on ground operations only

role in determining the population exposure of aviation emissions. Although STOL inherently yields higher terminal emissions per passenger than does CTOL, the advanced STOL propulsion technology employed leads to a net reduction. The increased air travel that would be stimulated by STOL service can be met with total emissions that are well below present levels.

3. HUB AIRCRAFT IMPACT

One of the potential benefits to be derived from satisfying short haul travel demand with STOL aircraft operating out of general aviation airports is the diversion of traffic from, and corresponding reduction in the need for, gates and parking structures at major hub airports. In this section, estimates are made at selected hub airports of the benefits of traffic diversion due to the implementation of STOL service.

a. Derivation of Parking Requirements

Minimum parking requirements were established using the basic data and relationships of Ref. 28. The expression used to calculate parking space requirements is:

$$P = 1.18 \times P_k \times V_p$$

where

- P = minimum number of spaces required
- P_k = peak-hour passengers
- V_p = number of inbound vehicles per passenger at the airport

The constant in this expression was developed by calibrating on the basis of current data from operations at La Guardia and O'Hare airports. Peak-hour passengers are found by using Figure 44, which relates peak-hour passengers to total annual passengers. Projected total annual traffic in 1980 was obtained through discussions with the planning departments at the airports evaluated. The number of inbound vehicles per passenger was found in Ref. 28.

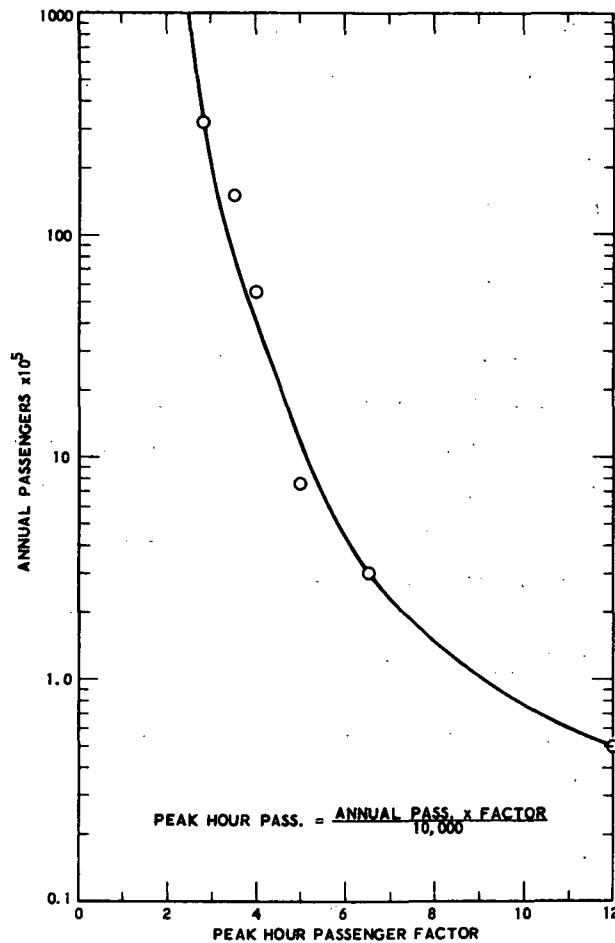

Figure 44. Peak-Hour Passenger Factor

b. Derivation of Gate Requirements

The number of gates needed is a function of peak-hour passengers and aircraft loading. Peak-hour passengers are found in Figure 44. As previously explained, the average airplane loading was developed by dividing the total number of passengers by the total number of operations at each airport. For forecasting purposes, the average loading for Los Angeles International Airport was obtained for 1969 and 1980 (the latter from the Airport Planning

Department), and this ratio was used to adjust other airport loading values to the forecast year. The expression used to compute gate requirements is:

$$G = 0.44 (P_k / E_d)$$

where

G = minimum number of gates needed

P_k = peak-hour passengers

E_d = enplanements per departure

The constant in this expression was developed by calibrating on the basis of current data from operations at La Guardia and O'Hare airports.

c. Benefits to Hub Airports

A quantitative evaluation of benefits was made for large CTOL airports in each of the arenas studied. The specific airports included were La Guardia in New York, O'Hare in Chicago, San Francisco International, and Los Angeles International. Planning departments were contacted at each of these airports to obtain estimates of current and future annual enplanements.

The Aerospace Corporation modal-split program was used to determine the modal split for CTOL, both with and without STOL service for each city pair of interest. This fractional CTOL traffic reduction was then multiplied by the two-way total daily demand for each city pair to obtain the net reduction in CTOL trips. To derive the passenger diversion for an airport in the California Corridor, this product was multiplied by the fraction of total city pair traffic using that specific airport, as found in California Public Utilities Commission publications (Ref. 29). In other arenas, the hub airports analyzed handle essentially all the short haul traffic for the city pairs involved. The results of these calculations were then summed over those city pairs able to support viable STOL service to obtain total passenger

diversions at each airport. Unit costs of \$2000 per parking space and \$100,000 per gate were used to calculate cost savings realized from the traffic diversion. Since enplanements at the CTOLports would be expected to continue growing, even after the introduction of STOL service, the diversion can be interpreted as a delay in the need for investment in expanded facilities. The delays were calculated using expected annual growth rates for each airport, as forecast by each airport's planning department.

Results of this analysis are shown in Table 30. The modest relief afforded the California ports can be attributed to the relatively small impact of STOL on CTOL traffic in that area. The impact on O'Hare Airport has a small time-delay effect because the fractional diversion is small, reflecting the traffic diversity at this airport and the relatively smaller fraction of that airport's short haul traffic represented by the study arena. The high degree of success of the STOL system in the Northeast Corridor manifests itself in the large impact shown for La Guardia Field.

To estimate the maximum congestion relief benefit, the foregoing calculations were repeated under the assumption that all origin and destination CTOL passengers in the city pairs studied would be diverted to STOL. These results are shown in the last three columns of Table 30, from which it can be seen that at La Guardia and O'Hare, the increased congestion relief is minimal, since most of the traffic is already captured by STOL. In the California Corridor, however, the additional relief to San Francisco and Los Angeles is substantial, since a larger fraction of travelers chose CTOL even when STOL was available.

It should be noted that these congestion-relief benefits apply only to the specific service paths considered in this study. As the use of STOL becomes more widespread and additional city pairs are served, the congestion-relief benefits at many major airports could become much more significant.

Table 30. Effect of STOL Service Introduction on CTOLport Congestion

Airport	1980 CTOL Forecast (without STOL)	Free Enterprise STOL Implementation			Forced Diversion of Short Haul O&D Traffic		
		Reduction Due to STOL Diversion	Cost Saving (\$)	Equivalent Delay in Construction (Years)	Reduction Due to STOL Diversion	Cost Saving (\$)	Equivalent Delay in Construction (Years)
<u>Los Angeles (LAX)</u>							
Passengers (Enplane & Deplane)	35,000,000	1,780,000		0.9	4,475,000		2.7
Parking Requirements (spaces)	14,481	594	1,190,000		1,622	3,244,000	
Gate Requirements	73	3	300,000		8	800,000	
<u>San Francisco (SFO)</u>							
Passengers (Enplane & Deplane)	25,000,000	2,100,000		1.4	4,350,000		3.0
Parking Requirements (spaces)	10,870	776	1,552,000		1,705	3,410,000	
Gate Requirements	56	4	400,000		8	800,000	
<u>O'Hare (ORD)</u>							
Passengers (Enplane & Deplane)	60,000,000	1,300,000		0.4	1,340,000		0.4
Parking Requirements (spaces)	17,708	391	782,000		462	924,000	
Gate Requirements	131	3	300,000		3	300,000	
<u>La Guardia (LGA)</u>							
Passengers (Enplane & Deplane)	24,000,000	4,150,000		3.3	4,615,000		3.7
Parking Requirements (spaces)	9,239	1,386	2,772,000		1,571	3,142,000	
Gate Requirements	60	8	800,000		10	1,000,000	

D. EXTENDED RANGE APPLICATION

The baseline STOL aircraft used in this study was designed for a range of 500 statute miles. An extended range version of this aircraft was examined on a route between New York City and Chicago STOLports. Since the nominal airline distance between these two cities is 720 miles, the baseline STOL aircraft was modified by offloading passengers and adding fuel capacity to provide the required range.

The 1980 CTOL service path characteristics were based on mid-1972 operations with a small frequency improvement forecast for the 1980 Midway-La Guardia service path. The fares are mid-1972 fares deflated to 1970 dollars. Table 31 shows the CTOL service path characteristics.

A complete modal split analysis of this extended range arena was not possible due to the lack of suitable origin and destination automobile traveler data. Hence, travel demand was based solely on projections of air travel growth. For 1968, the known Chicago-New York CTOL demand was estimated to be 75 percent of the total demand (Ref. 20). The 1980 total demand was found using the previously described total demand model. Applying the 1968 CTOL/total demand ratio to the projected 1980 total demand produced the results shown in Table 32. By comparison, an independent forecast of 1980 CTOL

Table 31. 1980 Chicago-New York CTOL Service

Service Path	Fare (1970 \$)	Time (hr)	Frequency (departures/hr)
ORD/LGA	54.69	1.95	2.8
ORD/EWR	54.69	1.95	0.9
ORD/JFK	54.69	2.10	0.5
MDW/LGA	54.69	1.90	0.43

ORD = O'Hare Airport, Chicago EWR = Newark Airport, N. Y.
MDW = Midway Airport, Chicago JFK = Kennedy Airport, N. Y.
LGA = La Guardia Airport, N. Y

Table 32. Chicago-New York Demand

Year	CTOL (Person-Trips)	Total (Person-Trips)
1968	1,719,000	2,292,000
1980	2,868,900	3,825,200

traffic (Ref. 30) amounted to 4,504,000 or 17.7 percent greater than the forecast obtained using the total-demand method.

Two Chicago STOLports (Meigs and Mitchell) and three New York STOLports (Secaucus, Mitchell, and Westchester) were considered, resulting in six possible service paths for analysis. STOL patronage was maximized when using the four-service-path case depicted in Figure 45. The potential viability of this hypothesized service is readily apparent, since, for aircraft sizes in excess of 100 passengers and an 8-percent ROI, this service captures over 90 percent of the air travelers in the Chicago-New York market.

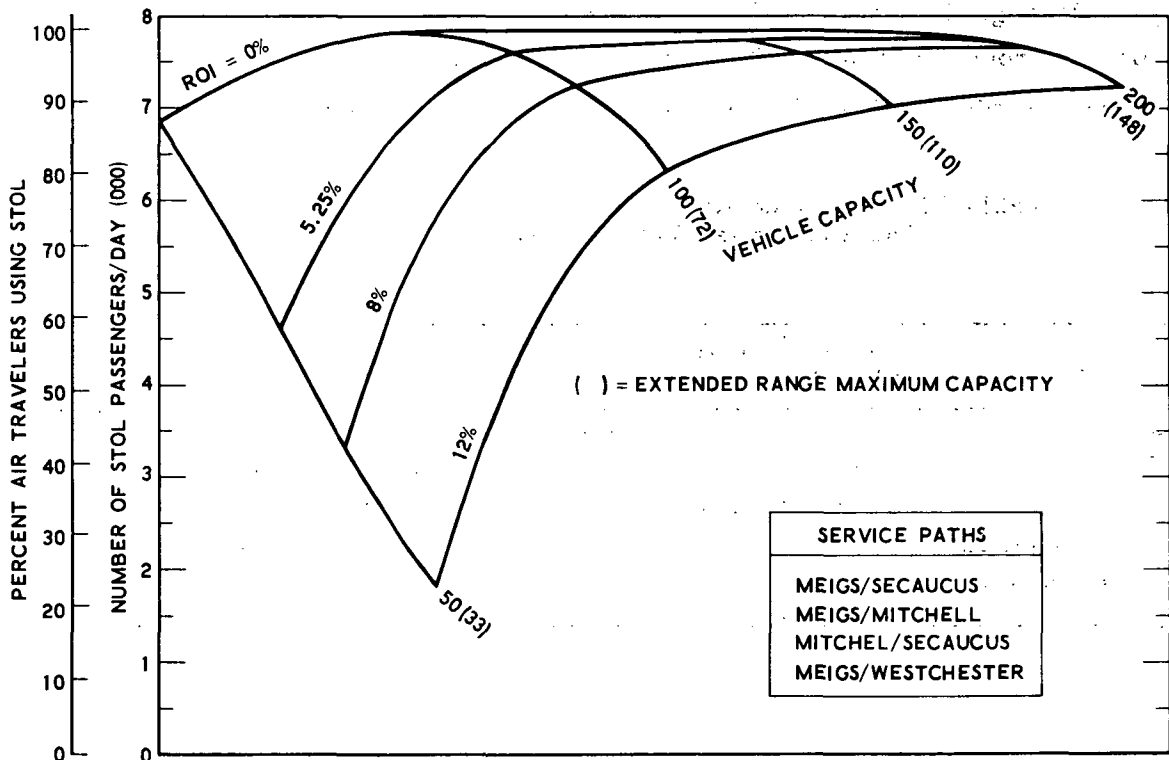

Figure 45. Chicago-New York STOL Air Demand

Some of the reasons for the success of the extended range STOL service can be seen in Table 33, which identifies characteristics of a 150-passenger aircraft which was limited to a maximum capacity of 110 passengers. For a nominal block distance of 720 miles, block times for STOL are approximately 1 hour and 40 minutes, compared to CTOL scheduled service of approximately 2 hours and 15 minutes. Block time savings are due principally to the assumed segregated air routes for the short haul STOL system. The passengers would also be attracted by reduced processing times in the smaller STOL ports and by the more convenient port locations. In addition to time savings, there is a 19-percent reduction in fare--from CTOL at \$54.69 (one-way) to STOL at \$44.45. The lower fare is primarily due to reduced operating costs resulting from the shorter block times.

Although the Chicago-New York service path is not considered as a short haul route, it can be efficiently served by the STOL aircraft system. Demand for such service would require a fleet of 24 STOL aircraft.

Table 33. Extended Range STOL System Characteristics, 150-Passenger Vehicle, ROI = 8 Percent

Service Path	Block Distance (mi)	Block Time (hr:min)	Fare (\$)	ROI (%)	Daily Person Trips	Headway (hr:min)	Fleet Size (No. A/C)
Chicago-New York			44.45	8.00	7590		24
Meigs-Secaucus	702	1:36		8.44	2524	0:49	
Meigs-Mitchell	727	1:39		7.68	1838	1:08	
Mitchel-Secaucus	724	1:39		7.77	1680	1:14	
Meigs-Westchester	719	1:38		7.92	1547	1:20	

Page Intentionally Left Blank

VII. CONCLUSIONS

A. STOL PATRONAGE POTENTIAL

When a STOL airline system, yielding a return on investment (ROI) of 8 percent and utilizing a 150-passenger aircraft, was placed in competition with a CTOL airline system, the combined systems produced a 6-percent increase in projected 1980 short haul origin and destination air travel within the California Corridor, a 66-percent increase in the Midwest Triangle, and an 88-percent increase in the Northeast Corridor. The STOL system attracted over 95 percent of the air travelers between the city pairs of the Northeast Corridor and the Midwest Triangle, but only about one-half of the air travelers in the California Corridor.

High-density STOL service between cities separated by distances of 100 miles or less appeared marginal due, primarily, to the highly competitive auto trip time and cost factors.

B. PRINCIPAL STOL SYSTEM ATTRIBUTES

The favorable potential of STOL service in both the Northeast Corridor and the Midwest Triangle can be attributed to a substantial reduction in both air travel time and cost. The block times of the STOL system are shorter than those of contemporary CTOL systems, which are assumed to continue operation in today's congested air and ground environments. Lower STOL fares reflect the shorter block times, and the resulting lower operating costs further enhance the short haul system's attractiveness. The fares also reflect, but to a lesser degree, the lower operating costs of a system whose service is virtually all high density, similar to current California intrastate operations.

The existing CTOL system in the California Corridor has superior time and cost characteristics and is less congested than those in the Northeast

Corridor and the Midwest Triangle. An examination of the dominant city pair of this arena, Los Angeles-San Francisco, indicated that about one-half of the 1980 origin and destination travelers would use the STOL system in spite of lower CTOL fares. Primary factors leading to this projection were STOLports located close to the centers of demand and minimum port-processing times. The STOL system succeeds best where CTOL congestion is highest or where geography or land use precludes locating CTOL airports nearer the centers of travel demand.

C. AIRCRAFT SIZE

Examination of STOL aircraft in sizes ranging from 50 to 200 passengers indicated that, because of the advantages of low operating costs, the 200-passenger configuration generated a higher passenger demand within the three arenas than did the smaller sizes. However, the levels of patronage were very similar for capacities between 100 and 200 passengers. At an 8-percent ROI, demand dropped less than 10 percent between 200- and 100-passenger sizes. However, between the 100- and 50-passenger sizes, operating efficiencies deteriorated rapidly, resulting in higher fares and corresponding reductions in STOL patronage. The combined results from all three arenas indicated that 50-passenger aircraft attracted only 65 percent of the 200-passenger demand. Where the competition with STOL was severe, as is the case in the California Corridor, the effect is more pronounced, with the 50-passenger aircraft attracting only 20 percent of the patronage drawn when using a 200-passenger aircraft.

D. FLEET REQUIREMENTS

Fleet-size requirements reflect the demand sensitivity to aircraft size. Where demand is less sensitive to aircraft size, as in the Northeast Corridor and the Midwest Triangle, reducing aircraft capacity from 100 to 50 passenger increases the required number of aircraft by over 60 percent. Where demand is very sensitive to size, as in California, the same size variation decreases the aircraft requirement by 30 percent.

The number of 150-passenger aircraft required to support a system configured to yield an 8-percent ROI in each of the three arenas is as follows:

- California - 14
- Midwest - 6
- Northeast - 32

E. EXTENDED RANGE POTENTIAL

A limited passenger version of the 500 statute mile aircraft design, operating on four service paths between two Chicago and three New York STOLports, attracts over 90 percent of all origin and destination air travelers in this market while still retaining economic viability. The requirement for 24 additional 150-passenger aircraft to implement this service suggests that extended-range applications may be a very important element in building an adequate production-base potential.

F. NOISE IMPACT

The STOL aircraft defined for this study has almost no adverse noise impact relative to the land use surrounding the selected airports. In those few cases where dedicated STOLports are assumed, the NEF=30 contour generated by the operations of STOL aircraft is contained totally within the airport boundaries. Therefore, special departure and approach corridors are not required to alleviate noise impact.

G. AIR POLLUTION IMPACT

The preliminary estimate of the amount of carbon monoxide, hydrocarbons, and oxides of nitrogen produced by the STOL aircraft system shows the level of these pollutants to be considerably lower than that of corresponding emissions from current-technology CTOL aircraft. Segregated airport operations and dedicated airspace help ensure low pollution levels by holding engine-on ground time to a minimum.

H. HUB AIRPORT CONGESTION RELIEF

Both ground and air congestion at major airports currently providing short haul air service can be relieved by dispersing short haul operations. The maximum relief at the four hub airports studied occurred at La Guardia, where 15 percent of the traffic could be removed by instituting STOL service at neighborhood airports. This could delay the need for expanding La Guardia capacity by approximately three years.

I. OPEN ISSUES--AIRCRAFT DESIGN ALTERNATIVES

In retrospect, two issues were identified which, while beyond the scope of the current study, are nevertheless significant in the continuing evaluation of the technology needed to satisfy future short haul air transportation requirements:

- The first issue is a better understanding of the sensitivity of total system economics and environmental impact to aircraft noise level. This study has shown that 95 EPNdB at a sideline distance of 500 feet may represent a higher level of noise suppression than is initially required. Some relaxation of this requirement may improve system economics without jeopardizing community acceptance, resulting in greater STOL patronage and a correspondingly higher production base.
- The second issue involves a better understanding of preferred field length capability. STOL aircraft designed to a 2000-foot, hot day balanced field length tend to yield a steeper terminal area flight profile (relative to longer field length designs) which, for equal noise levels, would reduce the noise impact. In addition, shorter field length capability permits STOL systems to operate out of a larger number of existing airports and provides more flexibility for siting new STOLports. New STOLport site acquisition and construction costs would also be lower with shorter field lengths. Countering these attributes are the higher development and operating costs anticipated for the shorter field length aircraft designs.

To better identify the appropriate design goals and required supporting technology, both with respect to aircraft noise levels and field length capability, additional aircraft concepts should be evaluated on a basis comparable to that in the present study.

REFERENCES

1. H. L. Solomon, Interim Report - Study of Short-Haul High-Density V/STOL Transportation Systems, Volume I. NASA Report No. CR-114466, The Aerospace Corporation, July 1972.
2. H. L. Solomon, Interim Report - Study of Short-Haul High-Density V/STOL Transportation Systems, Volume II Appendices, NASA Report No. CR-114467, The Aerospace Corporation, July 1972.
3. H. L. Solomon and S. Sokolsky, An Economic Assessment of STOL Aircraft Potential Including Terminal Area Environmental Considerations, ATR-73(7305)-1, Volume II, The Aerospace Corporation, June 1973.
4. Bolt, Beranek, and Newman, Inc., Noise in Urban and Suburban Areas, Results of Field Studies, U. S. Department of Housing and Urban Development, January 1967.
5. U. S. Department of Transportation, Assistant Secretary for Policy and Internal Affairs, Office of System Analysis and Information, Strategic Planning Division, Recommendations for Northeast Corridor Transportation, Volume II, Final Report, May 1971 (updated December 1971).
6. J. V. O'Keefe and G. S. Kelley, Design Integration and Noise Studies for Jet STOL Aircraft, Volume I, Program Summary, NASA CR-114471, The Boeing Company, May 1972.
7. Users Manual for VASCOMP II V/STOL Aircraft Sizing and Performance Computer Program prepared by Ventol Division, The Boeing Company, Philadelphia, Pa., Report No. D8-0375, March 1968, Revised October 1971.
8. W. C. Sperry, "Aircraft Noise Evaluation," FAA Report Number FAA-N0-68-34, September 1968.
9. L. Bogden and H. T. McAdams, Analysis of Aircraft Exhaust Emissions Measurements, Cornell Aeronautical Laboratory, Inc., Report No. CAL-NA-5007-K-1 and K-2, October 15, 1971.
10. Telecommunication with Dr. R. Sampson, Environmental Protection Agency, Ann Arbor, Michigan, January 19, 1973.

11. Proposed Standards for Control of Air Pollution from Aircraft and Aircraft Engines; General Motors Response to Proposed Part 87, Title 40, Code of Federal Regulations, 37 Federal Register 26488-26500, December 12, 1972; Environmental Activities Staff, General Motors Corporation, Warren, Michigan, February 10, 1973.
12. Takeoff and Landing Descriptions for Pollution Effect Comparison, The Aerospace Corporation, IOC from W. J. Portenier to Distribution, February 9, 1973.
13. Personal communication with Mr. D. E. Bell, Pratt and Whitney Aircraft, Los Angeles, California, January 18, 1973.
14. Planning and Design Criteria for Metropolitan STOLports, AC 150/5300-8, Federal Aviation Agency, November 5, 1970.
15. Airport Design Concepts for Short Haul Air Transportation Systems, ATM-70(7190), E. F. Schmidt, December 22, 1969.
16. Airport Paving, AC 150/5320-A6, Federal Aviation Agency, September 1968.
17. Airport Terminal Buildings, Federal Aviation Agency, Airport Division, September 1960.
18. Airport Aprons, AC 150/5335-2, Federal Aviation Agency, January 27, 1965.
19. Technique for Developing Noise Exposure Forecasts, Society of Automotive Engineers for Federal Aviation Agency - Department of Transportation, Technical Report FAA DS-67-14, August 1967.
20. H. M. Webb and W. J. Portenier, Study of V/STOL Aircraft Implementation, NASA Report No. CR-2227, The Aerospace Corporation, November 1972.
21. Economic Analysis of Engine Development, Detroit Diesel Allison Division of General Motors Corporation.
22. 1971 DOC and IOC Formula Update, Report D6-22514, The Boeing Company, July 1971.
23. 500 Largest Corporations, Fortune, May 1970, May 1972.
24. A. L. McPike, "Community Noise Levels of the DC-10 Aircraft," American Institute of Aeronautics and Astronautics, Journal of Aircraft, Volume 9, No. 8, August 1972.

25. Airport Capacity Criteria Used in Long-Range Planning, AC 150/5060-3A, Federal Aviation Agency, December 1969.
26. Bolt, Beranek, and Newman, Inc., Aviation Noise Evaluations and Projections, San Francisco Bay Area Region, ABAG, August 1967.
27. G. D. Kittredge and B. D. McNutt, "Role of NAPCA in Controlling Aircraft Pollutant Emissions," Society of Automotive Engineers, Conference on Aircraft and the Environment, Part 1, February 8-10, 1971.
28. "Access to Airports," Highway Research Record No. 274, Highway Research Board, 1969.
29. Passengers Onboard and Load Factors for Scheduled Air Carriers on Nonstop Flights Between California Airports, Quarters and 12 Months Ending June 30, 1971 and 1972. Calif. PUC Report No. 1504.26.
30. O&D Passenger Forecast, McDonnell-Douglas Corporation, September 1971.

GLOSSARY

A/C	aircraft
ACMD	Advanced Concepts and Missions Division
ANP	annual number of enplaning (STOL) passengers
AR	aspect ratio
ASM	available seat miles (statute miles)
ATR	Aerospace Technical Report
BATSC	Bay Area Transportation Study Commission
BT	block time
BTPR	Boston Transportation Planning Review
\bar{C}	mean aerodynamic chord
CAB	Civil Aeronautics Board
CATS	Chicago Area Transportation Study
CBD	central business district
CO	carbon monoxide
CT	Census of Transportation
CTOL	conventional takeoff and landing (aircraft)
DADZ	Data Aggregation Districts and Zones
DCD	Data Collection District
Δ IOC	port-related indirect operating cost
DOC	direct operating cost
DOT	Department of Transportation

DVRPC	Delaware Valley Regional Planning Commission
EAS	equivalent airspeed (knots)
EPA	Environmental Protection Agency
EPNL	effective perceived noise level
EWR	Newark Airport
FAA	Federal Aviation Agency
FAR	Federal Air Regulations
FPR	fan pressure ratio
GTOW	gross takeoff weight
HC	hydrocarbon
HPY	hours per year
IHSR-1	Interim High Speed Rail System, Option 1
IOC	indirect operating cost
JFK	Kennedy Airport
LARTS	Los Angeles Regional Transportation Study
LAX	Los Angeles International Airport
LGA	LaGuardia Airport
LTO	landing and takeoff
MDW	Midway Airport
NASA	National Aeronautics and Space Administration
ND	number of departures (annual)
NEC	Northeast Corridor

NECTP	Northeast Corridor Transportation Project
NEF	Noise Exposure Forecast
NOACA	Northeast Ohio Areawide Coordinating Agency
NO _x	oxides of nitrogen
Noy	unit used in calculation of PNL which weighs a noise spectrum based on subjective ratings of noise as a function of frequency and amplitude
NP	number of ports (STOL)
NPA	National Planning Association
NPR	nozzle pressure ratio
O&D	Origin and Destination
OASPL	overall sound pressure level
ORD	O'Hare Airport
P&W	Pratt & Whitney
PANCAP	practical annual capacity
Pax	passengers
pers mi	person miles
PK PNL	peak perceived noise level
PNL	perceived noise level
PSA	Pacific Southwest Airlines
PUC	Public Utilities Commission (California)
R	residential (zone)
ROI	return on investment
RP	planned residential (zone)

RPM	revenue passenger miles (statute miles)
S	commercial (zone)
SAE	Society of Automotive Engineers
SATS	Sacramento Transportation Study
SDMATS	San Diego Metropolitan Area Transportation Study
SFO	San Francisco International Airport
SM	statute mile
MSA	Standard Metropolitan Statistical Area
SPL	sound pressure level
STOL	short takeoff and landing (aircraft)
TALUS	Transportation and Land Use Study (Detroit)
TEB	tons of enplaning baggage
TSC	Transportation Systems Center
TSS	Transportation System Simulation
TWA	Trans World Airlines
UAL	United Airlines
VASCOMP	V/STOL Computer Program
W	manufacturing (zone)
WAL	Western Airlines
Z	unused land (zone)
ZA	airport zone



POSTMASTER: If Undeliverable (Section 158
Postal Manual) Do Not Return

"The aeronautical and space activities of the United States shall be conducted so as to contribute . . . to the expansion of human knowledge of phenomena in the atmosphere and space. The Administration shall provide for the widest practicable and appropriate dissemination of information concerning its activities and the results thereof."

—NATIONAL AERONAUTICS AND SPACE ACT OF 1958

NASA SCIENTIFIC AND TECHNICAL PUBLICATIONS

TECHNICAL REPORTS: Scientific and technical information considered important, complete, and a lasting contribution to existing knowledge.

TECHNICAL NOTES: Information less broad in scope but nevertheless of importance as a contribution to existing knowledge.

TECHNICAL MEMORANDUMS: Information receiving limited distribution because of preliminary data, security classification, or other reasons. Also includes conference proceedings with either limited or unlimited distribution.

CONTRACTOR REPORTS: Scientific and technical information generated under a NASA contract or grant and considered an important contribution to existing knowledge.

TECHNICAL TRANSLATIONS: Information published in a foreign language considered to merit NASA distribution in English.

SPECIAL PUBLICATIONS: Information derived from or of value to NASA activities. Publications include final reports of major projects, monographs, data compilations, handbooks, sourcebooks, and special bibliographies.

TECHNOLOGY UTILIZATION PUBLICATIONS: Information on technology used by NASA that may be of particular interest in commercial and other non-aerospace applications. Publications include Tech Briefs, Technology Utilization Reports and Technology Surveys.

Details on the availability of these publications may be obtained from:

SCIENTIFIC AND TECHNICAL INFORMATION OFFICE

NATIONAL AERONAUTICS AND SPACE ADMINISTRATION

Washington, D.C. 20546