

NASA TECHNICAL NOTE



NASA TN D-7703

NASA TN D-7703

FLIGHT EVALUATION OF ADVANCED
CONTROL SYSTEMS AND DISPLAYS
ON A GENERAL AVIATION AIRPLANE

*by Paul C. Loschke, Marvin R. Barber,
Einar K. Enevoldson, and Thomas C. McMurtry*

*Flight Research Center
Edwards, Calif. 93523*



NATIONAL AERONAUTICS AND SPACE ADMINISTRATION • WASHINGTON, D. C. • JUNE 1974

1. Report No. NASA TN D-7703		2. Government Accession No.		3. Recipient's Catalog No.	
4. Title and Subtitle FLIGHT EVALUATION OF ADVANCED CONTROL SYSTEMS AND DISPLAYS ON A GENERAL AVIATION AIRPLANE				5. Report Date June 1974	
				6. Performing Organization Code	
7. Author(s) Paul C. Loschke, Marvin R. Barber, Einar K. Enevoldson, and Thomas C. McMurtry				8. Performing Organization Report No. H-783	
9. Performing Organization Name and Address NASA Flight Research Center P. O. Box 273 Edwards, California 93523				10. Work Unit No. 501-23-21	
				11. Contract or Grant No.	
12. Sponsoring Agency Name and Address National Aeronautics and Space Administration Washington, D. C. 20546				13. Type of Report and Period Covered Technical Note	
				14. Sponsoring Agency Code	
15. Supplementary Notes					
16. Abstract A flight-test program was conducted to determine the effect of advanced flight control systems and displays on the handling qualities of a light twin-engined airplane. A flight-director display and an attitude-command control system, used separately and in combination, transformed a vehicle with poor handling qualities during ILS approaches in turbulent air into a vehicle with good handling qualities. The attitude-command control system also improved the ride qualities of the airplane. A rate-command control system made only small improvements to the airplane's ILS handling qualities in turbulence. Both the rate- and the attitude-command control systems reduced stall warning in the test airplane, increasing the likelihood of inadvertent stalls. The final approach to the point of flare was improved by both the rate- and the attitude-command control systems. However, the small control wheel deflections necessary to flare were unnatural and tended to cause over-controlling during flare. Airplane handling qualities are summarized for each control-system and display configuration.					
17. Key Words (Suggested by Author(s)) General aviation Stability augmentation systems General aviation handling qualities				18. Distribution Statement Unclassified - Unlimited CAT. 02	
19. Security Classif. (of this report) Unclassified		20. Security Classif. (of this page) Unclassified		21. No. of Pages 49	22. Price \$3.25

FLIGHT EVALUATION OF ADVANCED CONTROL SYSTEMS AND DISPLAYS
ON A GENERAL AVIATION AIRPLANE

Paul C. Loschke, Marvin R. Barber,
Einar K. Enevoldson, and Thomas C. McMurtry
Flight Research Center

INTRODUCTION

A survey of a cross section of light general aviation aircraft (ref. 1) indicated that the handling qualities of these aircraft, although generally satisfactory for visual and instrument flight in smooth air, were severely degraded by atmospheric turbulence. The degradation was most noticeable during ILS approaches because of the increase in pilot workload.

A broad spectrum of stability and control deficiencies contributed to the high workload. High control-system friction, low levels of longitudinal and spiral stability, high adverse yaw, objectionable Dutch-roll characteristics, large trim changes with changes in gear, flaps, and power, and control-system float combined to make precise instrument tracking in turbulence difficult even for experienced instrument pilots. Poor and inconsistent instrument displays compounded the problem.

In general, aircraft behavior can be improved by changes in the airplane's aerodynamic design or by the installation of advanced control systems. Improved displays are needed to complement either approach. In a flight-test program at the NASA Flight Research Center, an advanced control system and a flight director display were installed in a light twin-engined airplane, and the airplane's handling qualities were evaluated during ILS approaches in turbulent air. This report describes the hydraulic control system and flight control modes evaluated during the program and summarizes the results of the program. References 2 and 3 present preliminary program results.

SYMBOLS

Physical quantities in this report are presented in the International System of Units (SI) and parenthetically in U.S. Customary Units. The measurements were taken in U.S. Customary Units. Factors relating the two systems are presented in reference 4.

a_n	normal acceleration, g
a_y	transverse acceleration, g
F_a	aileron force, N (lb)
F_e	elevator force, N (lb)
F_r	rudder force, N (lb)
p	roll rate, deg/sec
q	pitch rate, deg/sec
r	yaw rate, deg/sec
s	Laplace transform variable
t	time, sec
V_i	indicated airspeed, knots
α	angle of attack, deg
β	angle of sideslip, deg
Δ	change in aircraft heading angle, deg
δ_a	total aileron deflection, deg
δ_{a_w}	aileron wheel position, deg
δ_e	elevator deflection, deg
δ_{e_w}	elevator wheel position, cm (in.)
δ_f	wing-flap deflection, deg
δ_r	rudder deflection, deg
δ_{r_p}	rudder pedal position, cm (in.)

θ	pitch angle, deg
φ	bank angle, deg
ψ	aircraft heading angle, deg

TEST AIRPLANE AND RESEARCH SYSTEMS

Test Airplane

The systems evaluated were tested in the airplane shown in figure 1. The airplane was a six-place, low-winged, twin-engined airplane that is representative of privately owned general aviation aircraft. Control was provided by conventional control surfaces. An all-movable horizontal stabilator with a geared antiservo tab provided longitudinal control. The stabilator could be deflected 4° trailing edge down and 14° trailing edge up. Both ailerons could be deflected 14° down and 18° up, and the rudder could be deflected $\pm 27^\circ$. The airplane was equipped with both mechanical and electrical longitudinal trim systems. Directional trim was provided by a mechanical bungee system.

Research Flight Control System

Control system mechanization.— The research flight control system installed in the test airplane consisted of a three-axis hydraulic system, electrically powered three-axis rate and attitude gyros, pilot control force and position transducers, and an electronics assembly box. Figure 2 shows the control system's mechanization in the pitch axis. The controls on the left side of the cockpit were mechanically disconnected from the conventional cable and pulley controls of the airplane. Artificial-feel bungees and electrical force and position transducers were installed on the left control wheel and rudder pedals. A hydraulic system was installed which included hydraulic pumps on both engines, electrohydraulic servovalves, and high-response actuators. The actuators were connected in parallel with the existing control cables and pulleys, which were controlled by the pilot on the right side of the cockpit. In all three axes, the control surfaces were at full authority when the actuators were fully extended.

The hydraulic system was designed to operate at a working pressure of 2.07×10^7 N/m² (3000 lb/in²) and a maximum flow rate of 0.012 m³/sec (1.85 gal/min). The design surface rate for all control surfaces was 60 deg/sec at one-third the maximum hinge moment. This allowed the actuators to be mechanized with wide bandwidth frequency response characteristics, which insured control over the aerodynamic modes that influenced the airplane's handling qualities.

The flight control system was designed for single-channel fail-safe operation. In the event of a failure in either the electrical or the hydraulic system, control of the airplane was transferred automatically from the evaluation pilot (left controls)

to the safety pilot (right controls). Since the actuators were connected in parallel with the mechanical control system, differential pressure across the actuators had to be relieved before the safety pilot could move the control surfaces freely. Therefore, redundancy was designed into the actuator depressurizing function to provide fail-safe control transfer. Figure 3 shows a schematic drawing of the servoactuator and hydraulic manifold that were used for all three control surfaces. The figure illustrates two methods for relieving pressure in the actuator.

The first method was through a solenoid valve, which was normally open. In the event of an electrical power failure, the solenoid valve dropped open and fluid passed through the valve. In addition, the solenoid valve opened automatically when preset levels of aircraft normal acceleration, angular rates, and control surface rates were exceeded. This insured the immediate transfer of control from the hydraulic controls to the safety pilot's controls if a failure induced a surface hard-over. The safety pilot could also deenergize the solenoid valve with a manual disconnect switch on his control wheel.

Pressure in the actuator could also be released through pressure relief valves connected in parallel with the actuator. If the solenoid valve malfunctioned, the safety pilot could exert override forces on the right controls to raise the relief valve. The relief valves opened at preset relief pressures and were installed so that pressure could be relieved from either end of the actuator. In selecting the relief pressure levels for each control axis, an attempt was made to minimize the override force for the safety pilot while maintaining an acceptable level of hinge-moment capability. If the relief pressure levels were set too low, the relief valves limited the available hinge moments and reduced the response capabilities of the actuators. The override forces chosen were ± 178 N (± 40 lb) for pitch, ± 134 N (± 30 lb) for roll, and ± 445 N (± 100 lb) for yaw.

An automatic hinge-moment nulling system was installed in the longitudinal axis to prevent large disengage transients. The stabilator hinge moment was automatically kept near zero when the hydraulic system was engaged. The stabilator antiservo tab was driven by strain gages attached to the actuator lever arm. This system insured that the airplane would not be overstressed by excessive stabilator hinge moments due to the automatic disengagement of the hydraulic system during high-g maneuvers.

Control system modes.— The research flight control system was designed so that the test airplane could be controlled through the hydraulic servoactuators in any of three control modes: the basic mode, the rate-command mode, or the attitude-command mode.

Basic mode: The basic mode provided the pilot with direct control of surface position. The servoactuators were mechanized with actuator position feedback and had a closed-loop natural frequency response of 6 hertz and a damping ratio of 0.7. The control gains were set so that the wheel-to-surface and pedal-to-surface gearing was the same as for the conventional mechanical controls.

The artificial-feel bungees were adjusted to approximate the force characteristics of the conventional controls during a 100-knot approach flight condition. Figures 4(a)

to 4(c) show the artificial-feel characteristics of the elevator, aileron, and rudder controls, respectively. These characteristics were not varied during the program.

Rate-command mode: The rate-command control system consisted of rate-command control in the pitch and roll axes and a rate damper in the yaw axis. The first mechanization used pitch and roll wheel position as the command signal. However, inherent deadband and hysteresis in the position transducer signal made precise trim control of pitch and roll rate difficult, especially when the attitude changes desired were small. Significant improvement resulted from using wheel force as the command signal: Deadband in the command signal was eliminated and exact control centering was possible.

Figure 5 shows a transfer function block diagram of the pitch-rate-command control system with the gains and shaping used during the ILS approach evaluations. The rate error signal was integrated in the shaping network and fed to the actuator, which drove the stabilator at a precise rate and direction. The result was that the airplane rate equaled the commanded rate. Lag compensation in the shaping network provided closed-loop damping of the phugoid mode, and therefore allowed precise control of pitch rate. The closed-loop natural frequency and damping of the longitudinal short-period mode did not differ significantly from the natural frequency and damping of the unaugmented longitudinal short-period mode.

Figure 6 shows a block diagram of the roll-rate-command control system. The gains and compensation shown are representative of the system's configuration during the ILS evaluations. The system was similar in design to the pitch-rate-command control system. The rate error signal was integrated to provide a roll rate equal to the commanded roll rate. The lead compensation in the shaping network provided closed-loop neutral spiral stability and also interacted with the roll mode to provide closed-loop second-order roll-rate response. The second-order roll-rate response had a natural frequency of approximately 1 hertz and a damping ratio of 0.5.

The yaw axis was mechanized with a yaw-rate damper during the evaluation of the rate-command control system. Figure 7 shows a block diagram of the yaw damper system. An aileron-to-rudder interconnect was mechanized as part of the yaw damper to minimize adverse aileron yaw. The time constant of the lagged interconnect signal was matched to the adverse yaw characteristics of the airplane when flown at the approach speed of 100 knots (see ref. 5). A washout network in the system eliminated actuator responses to steady-state yaw rate during constant rate turns. The yaw-rate damper increased the airplane's Dutch-roll damping ratio in the approach configuration from 0.1 to approximately 0.7.

Attitude-command mode: The attitude-command mode was mechanized to provide attitude command in the pitch and roll axes and a heading-hold capability in the yaw axis. Wheel position was used as the command signal for the pitch- and roll-attitude-command control systems. The poor centering characteristics of the wheel position signal did not degrade the control task appreciably, because the pilots could make precise corrections in pitch and roll attitude with the beep trim system. Force command, which had good centering characteristics, was used at first, but cross-coupling commands that were annoying during instrument approaches occurred

in pitch and roll. In general, wheel position provided the pilot with cues for determining the attitude of the airplane.

Figure 8 shows a block diagram of the pitch-attitude-command control system showing the shaping characteristics and feedback gains used during the instrument approach evaluations. When the pitch-attitude loop was closed, the pitch-rate inner loop provided short-period stability. The shaping network integrated the error signal, which resulted in the airplane's pitch attitude equaling the commanded pitch attitude. The lead term in the shaping network damped the highly oscillatory longitudinal phugoid mode, tightening pitch-attitude control.

Figure 9 shows a block diagram of the roll-attitude-command control system. Roll-rate feedback was mechanized as an inner loop that was similar to the inner loop in the pitch-axis mechanization. The use of roll-rate feedback increased the loop's sensitivity, which allowed the roll-attitude loop gains to be much smaller. Unlike the systems previously discussed, no integrating network was mechanized in the forward loop. The divergent spiral mode of the airplane, which had a very long time constant, was utilized as the error signal integrating device in the forward loop, and the mechanization of the system was therefore less complex. The shaping network provided closed-loop positive spiral stability. The dominant closed-loop roll response, which was second order, had a natural frequency of approximately 1 hertz and a damping ratio of 0.7.

Figure 10 shows a block diagram of the heading-hold mode mechanized in the yaw axis. The system was designed to maintain constant heading during level flight by mechanizing yaw rate and heading angle as feedback parameters to the rudder actuator. Yaw-rate feedback attenuated the Dutch-roll oscillation and increased the Dutch-roll damping to approximately 0.7. The heading-angle feedback loop opened when roll angle equaled or exceeded $\pm 3^\circ$ to permit turns. At the same time that the heading-angle loop opened, washed-out yaw rate was fed back to eliminate actuator responses during constant rate turns. An aileron-to-rudder interconnect was mechanized to eliminate high adverse aileron yaw as the pilot rolled into and out of the turn. The heading-hold loop also opened when the pilot activated the yaw beep trim. This allowed the pilot to trim sideslip with the wings level after a new heading was established. Moving the rudder pedals 0.64 centimeter (0.25 inch) or more also opened the heading loop. However, the pilots observed that they never needed to use the rudder pedals because the aileron-to-rudder interconnect provided coordination during turns.

Control-system step response characteristics.— The effects of the basic control system, the rate-command control system, and the attitude-command control system on the response characteristics of the airplane to control step inputs are compared in figures 11(a) and 11(b).

Longitudinal response: Figure 11(a) shows time histories of pitch angle, pitch rate, angle of attack, normal acceleration at the center of gravity, and stabilator response to a pilot control step input. With the basic control system, the step input was followed by an essentially constant angle-of-attack response and varying pitch angle, pitch rate, and normal acceleration. The control surface followed the pilot control input. The airplane tended to maintain elevated g until speed reduction

caused the g to dissipate. The airplane then stabilized at a new 1g trim speed and angle of attack.

With the rate-command control system, the step input produced a constant pitch-rate response and varying pitch angle, angle of attack, and normal acceleration. The system commanded the control surface at a constant rate to maintain constant pitch rate. The airplane tended to maintain a constant pitch rate as long as the command was present, and angle of attack increased until either the airplane stalled or the command was removed.

With the attitude-command control system, a step input produced constant pitch angle and variations in pitch rate, angle of attack, and normal acceleration. The control-surface response was rapid and quickly established a constant pitch attitude. Normal acceleration increased until the pitch angle stabilized. From then on, the airplane either climbed or dived, depending on the command, in trimmed 1g flight. Airspeed varied until the airplane stabilized on a new trim speed. Therefore, except for throttle changes, the attitude-command control system essentially provided flight-path control.

Lateral-directional response: A comparison of the effects of the basic control system, the rate-command control system, and the attitude-command control system on the lateral-directional response of the airplane is shown in figure 11(b). Time histories of bank angle, roll rate, yaw rate, and sideslip angle after an aileron step command are shown.

With the basic control system, the step input produced a reasonably constant roll rate and varying bank-angle, yaw-rate, and sideslip responses. The light damping of the Dutch-roll oscillations and the adverse yaw are apparent in the yaw-rate and sideslip responses. The negative spiral stability of the airplane is illustrated by the slight divergence in the roll rate.

With the rate-command control system, the step input resulted in a constant roll-rate and varying roll-angle, yaw-rate, and sideslip responses. The system provided effective yaw damping and essentially eliminated the adverse aileron yaw, as shown by the yaw-rate and sideslip responses.

With the attitude-command control system, a step input produced a constant bank angle and varying roll-rate, yaw-rate, and sideslip responses. The airplane remained at the commanded roll attitude until the stick input was removed. The yaw damper attenuated the Dutch-roll oscillations associated with yaw rate, and the interconnect eliminated adverse yaw and minimized the sideslip response as the aircraft rolled into the turn.

Instrument Displays

Basic display.— Figure 12 shows the basic instrument display, which was used during the first phase of the program. ILS approaches were flown with the basic display and the basic control system, rate-command control system, and attitude-command control system. As the directional gyro and artificial horizon indicators

show, the instruments were typical of general aviation aircraft. The basic guidance display operated from a conventional radio receiver, and glide-slope and localizer error information were presented on a conventional cross-pointer indicator.

Flight-director display.— To investigate the effects of advanced integrated displays on handling qualities during instrument approaches in turbulence, a flight-director display was installed in the test airplane. The flight-director display (fig. 13) included two large and well organized instruments which presented the airplane's attitude, orientation, and position relative to the ILS beam (ref. 6). The display included a pitch and roll command symbol, which, when nulled, relieved the pilot of mental workload for such tasks as intercepting the ILS beam. Pitch and roll steering commands were computed from data received from the glide-slope and localizer receivers, a gyro-stabilized magnetic compass, and a vertical gyro. The heading, course, and steering modes were selected by the pilot and manually entered into the system.

INSTRUMENTATION

Data Recording System

A pulse-code-modulation (PCM) digital data acquisition system was used during the flight-test program. Data were recorded on board the airplane and by telemetry at a ground station. Table 1 lists the range and sensitivity of each parameter recorded during the evaluations. Angle of attack and angle of sideslip were measured with boom-mounted vanes on the wing of the airplane; the measurements were not corrected for angular velocity or boom bending. A cockpit camera was used to photograph the instrument display, and a tail-mounted camera photographed the aircraft's ground track relative to the runway during the approaches.

Turbulence-Intensity Measurement System

It was obvious at the outset that the research flight control system would conceal turbulence from the pilot to some extent. Therefore, a turbulence-intensity measurement system was used during the program to measure the turbulence in which the airplane was operating (ref. 7). The turbulence-intensity measurement system is described in detail in the appendix.

TEST CONDITIONS

Task

ILS approaches were used to evaluate the effect of the advanced control systems on the handling qualities of the test airplane. To complete an instrument approach to minimums and land an airplane, a pilot must use all the controls, make power changes, maintain radio communication, and make efficient use of the instrument

display. The task enables a pilot to evaluate airplane stability, control harmony, display location and efficiency, and man-machine integration.

To simulate IFR conditions during the approaches, orange plastic was installed on the windshield and side windows, and the evaluation pilot wore blue goggles. The orange-blue combination effectively prevented the evaluation pilot from seeing outside the airplane. The instrument panel was illuminated with high-intensity white light so the evaluation pilot could read the instruments while wearing the blue goggles. However, the orange plastic did not prevent the safety pilot from maintaining VFR flight conditions. Data recording was initiated approximately 5 nautical miles from the end of the runway for each approach and terminated at a decision height of 63 meters (200 feet).

Because atmospheric turbulence severely degraded the airplane's handling qualities under instrument flight conditions, quantitative and qualitative data were recorded during ILS approaches flown in various levels of turbulence intensity. Each control system and display configuration was evaluated over a wide range of turbulence intensity.

Evaluation Pilots

Two experienced flight-test pilots made most of the handling qualities evaluations during the program. However, other instrument-rated pilots with widely varying backgrounds also made evaluations. Approximately 20 instrument approaches were flown with each control-system configuration, and all the pilots evaluated each control system and display configuration at least once.

RESULTS AND DISCUSSION

Effect of Control Systems and Displays on Handling Qualities

Basic control system.— Figure 14 shows Cooper-Harper pilot ratings for the ILS approaches flown in the basic airplane. The figure shows the effect of atmospheric turbulence on the pilot's ability to perform the task. The ordinate is a condensation of the Cooper-Harper rating scale. The abscissa is the measured root-mean-squared (rms) value of turbulence intensity. The indications of light and moderate were determined from previous tests of the turbulence-intensity measurement system in the test airplane; the U.S. Weather Bureau's turbulence reporting criteria (table 2) were used as a basis for the determinations (ref. 8).

In relatively smooth air the airplane's handling qualities during the ILS approaches were rated 4, somewhat less than satisfactory. The rating degraded to 8 when the turbulence reached a moderate level. This rating indicated that the airplane's handling characteristics were unacceptable and that substantial pilot skill was necessary to maintain control. The airplane exhibited continual Dutch-roll oscillations and trim changes with power, both longitudinal and directional. Because of the poor instrument display and the light damping of the Dutch-roll

oscillations, the pilot could not keep the average airplane heading within 10° . Frequent power changes, which were necessary to correct for up and down drafts, resulted in directional and longitudinal trim changes. In addition, the airplane tended to pitch into each gust, amplifying the trim changes caused by the gusts.

Figure 15 shows a time history of the last 2 minutes of a typical ILS approach in turbulence with the basic controls and the basic instrument display. A turbulence intensity of 0.44 meter per second (1.45 feet per second) rms was measured during the approach. The aircraft motion excited by gust disturbances is apparent in the rate and attitude traces. The large, lightly damped Dutch-roll oscillations shown in the yaw-rate trace continually rolled the airplane off the desired heading, which resulted in deviations from the localizer track. The high adverse yaw of the airplane compounded the azimuth control problem by introducing heading lag when small changes in heading were desired. Frequent and sometimes large lateral control inputs were necessary to keep the airplane within 1° of the localizer beam. Continuous disturbances in pitch attitude due to turbulence made it difficult to maintain trim and therefore caused large offsets and variations in the glide-slope error. Constant pilot inputs were necessary to keep the airplane within the $\pm 0.5^\circ$ limits of the glide-slope beam.

Rate-command control system.— Figure 16 shows pilot ratings of the airplane's handling qualities with the rate-command control system and compares them with a fairing of the ratings obtained with the basic control system. With the rate-command control system, the handling qualities are still rated unsatisfactory. The ratings show that the airplane was no easier to control with the rate-command control system than with the basic control system in smooth air, but that the rate-command control system did improve the airplane's handling qualities at higher turbulence intensities. The pilots attributed the improvement partly to the damping of the airplane's response to gusts. The rate-command control system also improved the airplane's handling qualities by eliminating the trim changes with changes in power, gear, and flaps. However, the system was difficult to trim, and the airplane drifted continuously about the pitch and roll axes at a rate of approximately 5 degrees per minute. For this reason, constant attention was necessary to keep the airplane on the ILS beam.

Figure 17 shows a time history of an ILS approach in turbulence with the rate-command control system and the basic instrument display. The measured turbulence recorded for the approach was 0.43 meter per second (1.40 feet per second) rms. A comparison with figure 15 shows the improvement in the airplane's handling qualities with the rate-command control system. Airplane motion was noticeably reduced. Yaw-rate response to turbulence was well damped except when large bank angles were commanded. Pitch and roll pilot inputs were considerably smaller than with the basic control system. The ILS glide-slope and localizer deviations were somewhat smaller than with the basic control system, although there was no significant improvement in tracking the beam.

Attitude-command control system.— Figure 18 presents pilot ratings of the airplane's handling qualities for approaches flown with the attitude-command control system and shows the improvement in the ratings over those for the basic and rate-command control system. The airplane's handling qualities with the

attitude-command control system were rated satisfactory out to high levels of turbulence intensity.

The attitude-command control system damped the response of the airplane to turbulence, and, because it provided attitude stabilization, controlling the airplane required little of the pilot's attention. Thus, when flying the ILS approach, the pilot could devote his attention to such other matters as reading an approach plate and be sure that the airplane would be in the same attitude when he returned to the control task. The attitude-command control system also eliminated trim changes with changes in gear, flaps, and power; provided a high level of pitch and roll stability, reducing the airplane's tendency to pitch into gusts; and eliminated the airplane's objectionable Dutch-roll characteristics. In addition, the aileron-to-rudder interconnect eliminated the adverse yaw.

Additional ILS approaches were flown with various combinations of basic and attitude-command control to determine the effect of augmenting each control axis on the airplane's handling qualities. Each axis was flown in the basic control configuration with the remaining two axes in the attitude-command configuration. The pilots found that removing augmentation from any of the control axes approximately doubled the workload of flying with augmentation in all axes.

A time history of an ILS approach in turbulence with the attitude-command control system and the basic instrument display is shown in figure 19. The measured turbulence intensity during the approach was 0.49 meter per second (1.60 feet per second) rms. A comparison of this figure with figures 18 and 20 illustrates that the attitude-command control system significantly improved the airplane's handling qualities, even though the intensity of the turbulence for the attitude-command control system was higher. The system maintained longitudinal trim without pilot input. However, the increased stability provided by the attitude-command control system did not reduce the controllability of the airplane, as shown by the pitch and roll control force and attitude traces: The attitude-command control system allowed the pilot to make precise control inputs when necessary in addition to providing a high level of stability that kept the airplane at trim attitudes.

Basic instrument and flight-director display.— Figure 20 presents the pilot ratings of handling qualities for ILS approaches flown with the basic instrument and flight-director displays in varying intensities of turbulence. With both display configurations, the basic control system was used during the approaches. The figure shows that the flight-director display significantly improved the pilots' opinions of the task. However, the handling qualities still degraded as turbulence intensity increased.

The pilots commented that to monitor the basic instrument display (fig. 12) they had to scan half the instrument panel. Furthermore, the engine performance instruments were on the other side of the cockpit. The head movement necessary to monitor them caused a significant time loss because the pilot's eyes had to refocus. Monitoring the ILS instruments in conjunction with the directional gyro was particularly difficult. In addition, the attitude indicator was difficult to interpret rapidly because of its lack of sensitivity, small size, and cluttered appearance. These deficiencies made the instruments impossible to monitor with peripheral vision.

The instruments were better located in the flight-director display (fig. 13). The area of the primary scan pattern was significantly smaller, although engine monitoring still required large head movements. The size of the attitude and compass displays made it possible to interpret them rapidly and to sense display movement with peripheral vision. The placement of the two displays (one above the other) also made peripheral interpretation easier. In addition, the flight-director compass display was slaved to the magnetic heading, so the pilot did not have to set the compass manually, a difficult and inaccurate procedure in the presence of turbulence.

The command features of the flight-director display also reduced the pilot's mental workload during ILS approaches. Estimation of the proper heading to keep the airplane on the localizer beam in the presence of a crosswind and the integration necessary to determine heading leads on rollout were eliminated by the steering commands of the flight-director display. However, the pilots commented that they were helped more by the improvement in the scan pattern than by the command features of the flight-director display.

Figure 21 shows a time history of an ILS approach in turbulence with the basic control system and the flight-director display. A turbulence intensity of 0.40 meter per second (1.32 feet per second) rms was measured during the approach. A comparison of this figure and figure 15, which is for the basic control system and the basic display, illustrates the improvement in performance due to the flight-director display. Both time histories show large airplane response due to gusts and large pilot control inputs. However, the flight-director display provided proper pitch and roll commands, enabling the pilot to follow the localizer and glide-slope beam more accurately than the basic display configuration. Figure 22 presents pilot ratings for the ILS approaches flown with the attitude-command control system with and without the flight-director display. The average pilot rating changed from approximately 2.5 for the attitude-command control system alone to 1.3 for the attitude-command control system with the flight-director display. Several perfect ratings were given at the lower turbulence levels.

A comparison of figures 20 and 22 reveals that in smooth air the ratings of the basic display with the attitude-command control system and the flight-director display with the basic control system are approximately equal. However, turbulence degraded the ratings of the flight-director display with the basic control system at approximately the same rate as it did the ratings of the basic display with the basic control system.

Effect of advanced control systems on the performance of noninstrument-rated pilots.— A limited evaluation was made of the effects of the attitude-command control system on the performance of noninstrument-rated pilots during an IFR mission. The evaluation was made to determine whether the system was of benefit to the noninstrument-rated pilot who strays into IFR flight conditions. The evaluation was made by training three noninstrument-rated pilots, who each had approximately 200 hours of VFR flight time, to make a typical IFR flight using the attitude-command control system. They were then asked to fly the same pattern using the basic control system. No attempt was made to evaluate the effect of the flight-director display on the performance of these pilots because the sequencing of the flight-director display varies from mission to mission. Thus, although the pilot

could have learned to use the display during one mission, he may not have been able to sequence it properly for any other.

The pattern of the IFR mission is shown in figure 23. The evaluation pilot was to take control of the airplane at a predetermined point. The pattern he was to fly consisted of straight flight for 15 nautical miles, a turn toward Palmdale VOR, and an entry into the holding pattern for a VOR approach. After completing the VOR approach, he was to be vectored to return to Edwards, where he was to perform an ILS approach to minimums. This approach terminated the evaluation flight. Communications were to be handled by the safety pilot, but all other functions were to be performed by the evaluation pilot.

All three pilots performed the mission satisfactorily after two flights with the attitude-command control system. One of the three pilots was then able to perform the mission using the basic control system, but the other two were unable to fly even the straight 15-nautical-mile segment of the flight. Figure 24 shows the performance of one of the pilots with the attitude-command control system and the basic control system. He was able to complete the mission with the attitude-command control system, but he flew only 3 nautical miles with the basic control system before the safety pilot had to resume control. Without the attitude-command control system he could not even keep the airplane upright. (There was only light turbulence during these flights.)

The evaluations indicated that the attitude-command control system did reduce the VFR pilot's workload under IFR conditions and that the improved handling qualities provided by the system would help the noninstrument-rated pilot cope with an inadvertent IFR encounter.

Gust alleviation.— Figure 25 illustrates the improvement in the airplane's response to turbulence due to the attitude-command control system. The time histories shown were obtained during consecutive intervals of one flight, with the attitude-command control system switched on and then off in level flight. Since the data were taken during one flight, the turbulence level was approximately the same for both control-system configurations (0.52 meter per second (1.7 feet per second)). The data show that the attitude-command control system reduces the airplane's response to turbulence. Normal-acceleration deviations are significantly smaller at the short-period frequencies. The reduced lateral-directional motion is primarily the result of increased Dutch-roll damping and spiral stability; during the control-system-off tests, the pilot had to make occasional aileron control inputs to keep the airplane upright.

Stalls.— With medium power settings, the basic airplane developed a rolloff just before stalling. This rolloff became very sharp if full power was used throughout the stall. When stalled with power settings low enough to remain free of the rolloff, the airplane could establish longitudinal trim at an angle of attack higher than that required for stall. The trim condition was established as the pilot commanded full nose-up stabilator at the first indication of stall. The airplane had relatively good stall warning in the form of airframe buffet, and a large amount of nose-up stabilator was required to pull the airplane into a stall.

Both the rate- and attitude-command control systems eliminated the rolloff tendency inherent in the airplane. Even at high power settings, the systems kept the wings level. However, both systems provided nose-up elevator commands that placed the airplane in a poststall trim condition. This was deemed to be undesirable, because in an airplane without good stall warning the pilot may believe that he has control of the airplane when actually he must still recover from the stall. The recovery usually means losing approximately 61 meters (200 feet) of altitude before the airplane will fly a level flight path.

Both control systems increased the likelihood of inadvertent stalls. As mentioned, a large nose-up stabilator deflection was necessary to pull the test airplane into a stall. With the rate-command system, a small control command produced a nose-up pitch rate that was sustained until full-up stabilator was reached. During the tests with the rate-command control system, a highly experienced test pilot inadvertently stalled the airplane. With the basic control system, the trim changes with power tended to lower the nose when power was reduced, helping the pilot to maintain the desired airspeed. The attitude-command control system did not have this effect. As power was reduced, the altitude-command system commanded more up stabilator to maintain trim altitude, which tended to create inadvertent stall conditions. However, there were no inadvertent stalls during the attitude-command evaluations.

Because of these characteristics, changes should be made to the command control systems that improve stall warning or eliminate stall; one possibility would be limiting angle of attack.

Takeoff and landing.— Both the rate- and the attitude-command control systems improved the final approach to the flare point. This improvement was primarily the result of better attitude stability and the alleviation of the handling-qualities problems caused by gusts. Neither system improved the airplane's flare characteristics. With both control systems, the nose-up control wheel deflections necessary to maintain the flare attitude were small, which was disconcerting to the pilots. They commented that the large deflections required to perform the flare in unmodified light aircraft provided a measure of stall warning and speed control and reduced the tendency to overcontrol the airplane. The pilots disliked the rate-command control system during flare more than the attitude-command control system because with it they had to return the control wheel to the neutral position after establishing the flare attitude. The pilots observed that years of conditioning made it unnatural to move the control wheel in a nose-down direction during the landing flare. For the attitude-command control system to provide satisfactory handling qualities during the flare, it should be modified to require larger wheel deflections during the landing flare. However, no effort was made during the course of the program to make such a modification.

Both the rate- and the attitude-command control systems improved the takeoff characteristics of the airplane because they eliminated the trim changes associated with changes in gear, flaps, and power, thereby providing the pilot with better attitude control.

Sudden engine failure.— To simulate a sudden engine failure, one throttle was rapidly closed to the idle power setting. Failures of both the right and left engines were simulated during climbs for the rate- and the attitude-command control systems. Both control systems eliminated the large, rapid yaw and roll responses in the direction of the failed engine that characterized the basic airplane. With both systems, the airplane entered shallow turns in the direction of the failed engine. With the rate-command control system the airplane entered a shallow dive, but with the attitude-command control system pitch attitude remained constant and airspeed decreased by approximately 10 knots in 30 seconds. Both systems provided the pilot with enough time to initiate recovery.

CONCLUSIONS

A research flight control system and a flight-director display were installed on a typical twin-engined general aviation airplane. A flight-test program was conducted to evaluate the effects of these systems on the handling qualities of the airplane during ILS approaches in turbulence. The effects of the flight control system on the airplane's ride qualities in turbulent air was also investigated. The systems were also evaluated under other operational conditions. The following conclusions were drawn:

- (1) A flight-director display and an attitude-command control system used in combination during ILS approaches in turbulent air significantly improved the handling qualities of the airplane.
- (2) The flight-director display and the attitude-command control system were also of significant benefit during ILS approaches when used separately.
- (3) The attitude-command control system improved the ability of noninstrument-rated pilots to cope with IFR flight.
- (4) The rate-command control system made only small improvements to the airplane's handling qualities during ILS approaches.
- (5) Both the rate- and the attitude-command control systems improved the final approach to the flare point. However, the small control stick deflections necessary to flare were unnatural and tended to cause overcontrol during flare. The airplane's takeoff characteristics were improved because the trim changes associated with changes in gear, flaps, and power were eliminated.
- (6) Both control systems effectively prevented rolloff in the test airplane during stalls. However, stall warning was reduced, increasing the likelihood of inadvertent stalls.
- (7) The airplane's response to simulated engine failure was considerably improved by both the rate- and the attitude-command control systems. Large, rapid

yaw and roll responses in the direction of the failed engine were eliminated. With both systems the airplane entered a gentle turn into the dead engine.

Flight Research Center

National Aeronautics and Space Administration

Edwards, Calif., April 12, 1974

APPENDIX

TURBULENCE-INTENSITY MEASUREMENT SYSTEM

Figure 26 shows the mechanization of the turbulence-intensity measurement system. A pitot-static probe and a differential pressure transducer measured the longitudinal pressure fluctuations in front of the airplane. A bandpass filter attenuated deviations above 20 hertz and below 6 hertz to exclude unwanted high-frequency noise and low-frequency airplane response to turbulence and control inputs. The signal was then integrated in the computer and recorded in the data system. The computer also compensated for variations in the signal due to airplane velocity.

The recorded signal is directly proportional to the shaded area in the turbulence power spectrum in figure 26. The power spectrum shown represents the standard format for quantitative turbulence measurements. This format is the result of extensive turbulence research (ref. 9) which showed empirically that the log-log plot of the gust-velocity power spectrum is linear and has a constant and repeatable slope throughout the wavelength range from 3.05 meters to 305 meters (10 feet to 10,000 feet). Therefore, changes in turbulence intensity change the magnitude of the spectrum but not its slope. The invariance of the slope is illustrated in the figure by the levels of light-to-moderate and moderate-plus turbulence spectra taken from reference 10. Therefore, the shaded area varies directly with the level of turbulence intensity. This area is also directly proportional to the root-mean-squared value of the gust velocity, which is equal to the magnitude of the area under the entire power spectral curve.

REFERENCES

1. Barber, Marvin R.; Jones, Charles K.; Sisk, Thomas R.; and Haise, Fred W.: An Evaluation of the Handling Qualities of Seven General-Aviation Aircraft. NASA TN D-3726, 1966.
2. Loschke, Paul C.; Barber, Marvin R.; Jarvis, Calvin R.; and Enevoldson, Einar K.: Handling Qualities of Light Aircraft With Advanced Control Systems and Displays. NASA Aircraft Safety and Operating Problems, Volume 1, NASA SP-270, 1971.
3. Loschke, Paul C.; Barber, Marvin R.; Jarvis, Calvin R.; and Enevoldson, Einar K.: Flight Evaluations of the Effect of Advanced Control Systems and Displays on the Handling Qualities of a General Aviation Airplane. Paper no. 720316, SAE, Mar. 15-17, 1972.
4. Mechtly, E. A.: The International System of Units - Physical Constants and Conversion Factors (Rev.). NASA SP-7012, 1969.
5. Blakelock, John H.: Automatic Control of Aircraft and Missiles. John Wiley & Sons, Inc., c.1965, pp. 149-152.
6. Anon.: FD-108/FD-108G/FD-109G Integrated Flight Systems - Maintenance Manual. 523-0759331-101114, Collins Radio Co., Mar. 15, 1967 (rev. June 15, 1967).
7. Mac Cready, Paul B., Jr.; Williamson, Robin E.; Berman, Stephen; and Webster, Alexander: Operational Application of a Universal Turbulence Measuring System. NASA CR-62025, 1965.
8. Anon.: IFR - Supplement. United States. DOD Flight Information Publication, June 21, 1973, to July 19, 1973. Defense Mapping Agency Aerospace Center (St. Louis Air Force Station, Mo. 63118), p. 460.
9. Houbolt, John C.; Steiner, Roy; and Pratt, Kermit G.: Dynamic Response of Airplanes to Atmospheric Turbulence Including Flight Data on Input and Response. NASA TR R-199, 1964.
10. Anon.: Airplane Strength and Rigidity Reliability Requirements, Repeated Loads, and Fatigue. Military Specification MIL-A-8866(ASG), May 18, 1960.

TABLE 1. - RECORDED PARAMETERS

Parameter	Range	Sensitivity
Altitude, m (ft)	6100 (20,000)	16 (54)
Airspeed, knots	270	1
Angle of attack, deg	-5 to 18	0.1
Angle of sideslip, deg	±20	0.1
Longitudinal acceleration, g	±0.25	0.002
Lateral acceleration, g	±0.25	0.002
Normal acceleration, g	0 to 2	0.02
Pitch rate, deg/sec	±20	0.07
Roll rate, deg/sec	±60	0.2
Yaw rate, deg/sec	±20	0.07
Pitch angle, deg	±15	0.06
Roll angle, deg	±20	0.1
Heading angle, deg	360	0.6
Longitudinal wheel force, N (lb)	±360 (80)	1.8 (0.4)
Lateral wheel force, N (lb)	±360 (80)	1.8 (0.4)
Pedal force, N (lb)	±712 (160)	8.9 (2)
Elevator wheel position, m (in.)	0 to 0.228 (0 to 9)	0.0004 (0.014)
Aileron wheel position, deg	±60	0.75
Rudder pedal position, m (in.)	±0.099 (3.9)	0.00027 (0.0106)
Stabilator position, deg	-15 to 5	0.05
Total aileron position, deg	±34	0.15
Rudder position, deg	±24	0.2
ILS glide-slope error, deg	±0.5	0.02
ILS localizer error, deg	±2.5	0.1
Turbulence intensity, m/sec (ft/sec)	2.1 (7)	0.003 (0.01)

TABLE 2.— TURBULENCE REPORTING CRITERIA

[From ref. 8]

INTENSITY	AIRCRAFT REACTION	REACTION INSIDE AIRCRAFT
LIGHT	<p>Turbulence that momentarily causes slight, erratic changes in altitude and/or attitude (pitch, roll, yaw). Report as Light Turbulence;[*]</p> <p>or</p> <p>Turbulence that causes slight, rapid and somewhat rhythmic bumpiness without appreciable changes in altitude or attitude. Report as Light Chop.</p>	<p>Occupants may feel a slight strain against seat belts or shoulder straps. Unsecured objects may be displaced slightly. Food service may be conducted and little or no difficulty is encountered in walking.</p>
MODERATE	<p>Turbulence that is similar to Light Turbulence but of greater intensity. Changes in altitude and/or attitude occur but the aircraft remains in positive control at all times. It usually causes variations in indicated airspeed. Report as Moderate Turbulence;[*]</p> <p>or</p> <p>Turbulence that is similar to Light Chop but of greater intensity. It causes rapid bumps or jolts without appreciable changes in aircraft altitude or attitude. Report as Moderate Chop.</p>	<p>Occupants feel definite strains against seat belts or shoulder straps. Unsecured objects are dislodged. Food service and walking are difficult.</p>
SEVERE	<p>Turbulence that causes large, abrupt changes in altitude and/or attitude. It usually causes large variations in indicated airspeed. Aircraft may be momentarily out of control. Report as Severe Turbulence.[*]</p>	<p>Occupants are forced violently against seat belts or shoulder straps. Unsecured objects are tossed about. Food service and walking are impossible.</p>
EXTREME	<p>Turbulence in which the aircraft is violently tossed about and is practically impossible to control. It may cause structural damage. Report as Extreme Turbulence.[*]</p>	

^{*} High level turbulence (normally above 15,000 feet MSL) not associated with cumuliform cloudiness, including thunderstorms, should be reported as CAT (clear air turbulence) preceded by the appropriate intensity, or light or moderate chop.

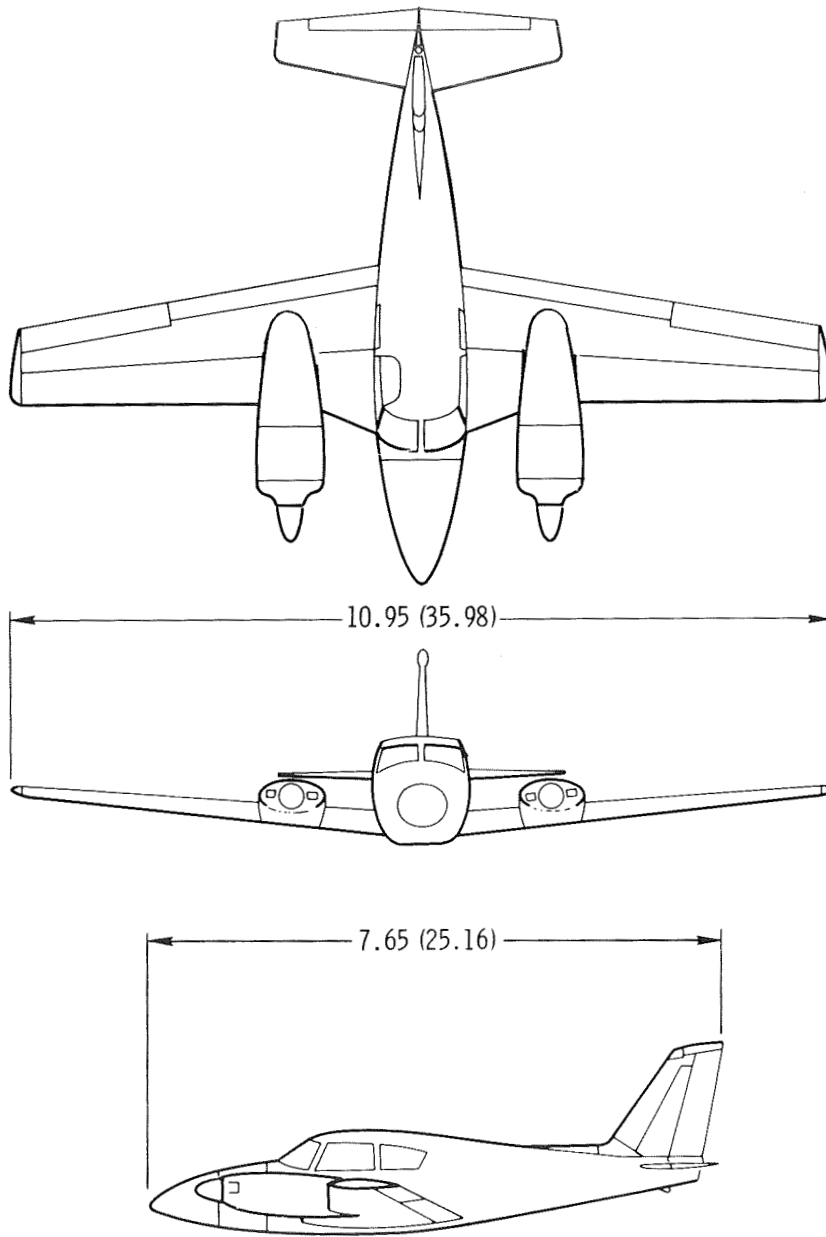

Figure 1. Three-view drawing of test airplane. Dimensions are in meters (feet).

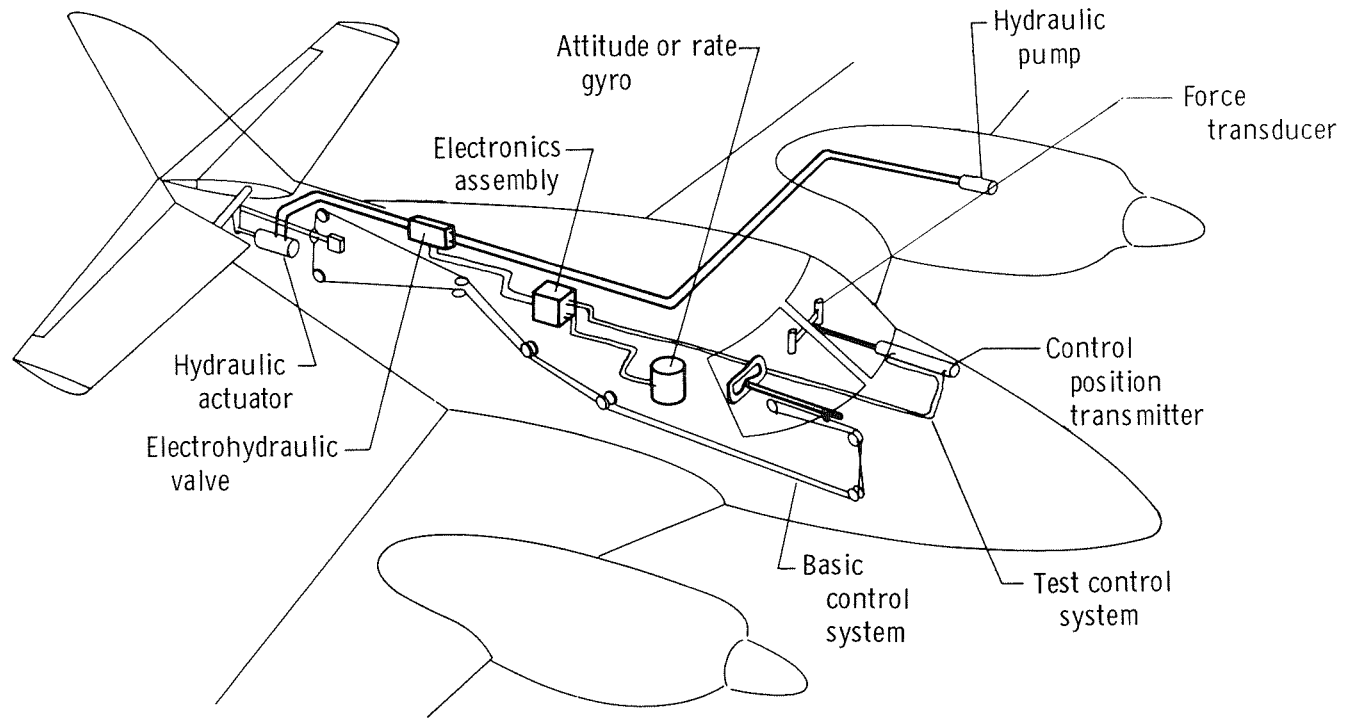

Figure 2. Test control system mechanization in pitch axis.

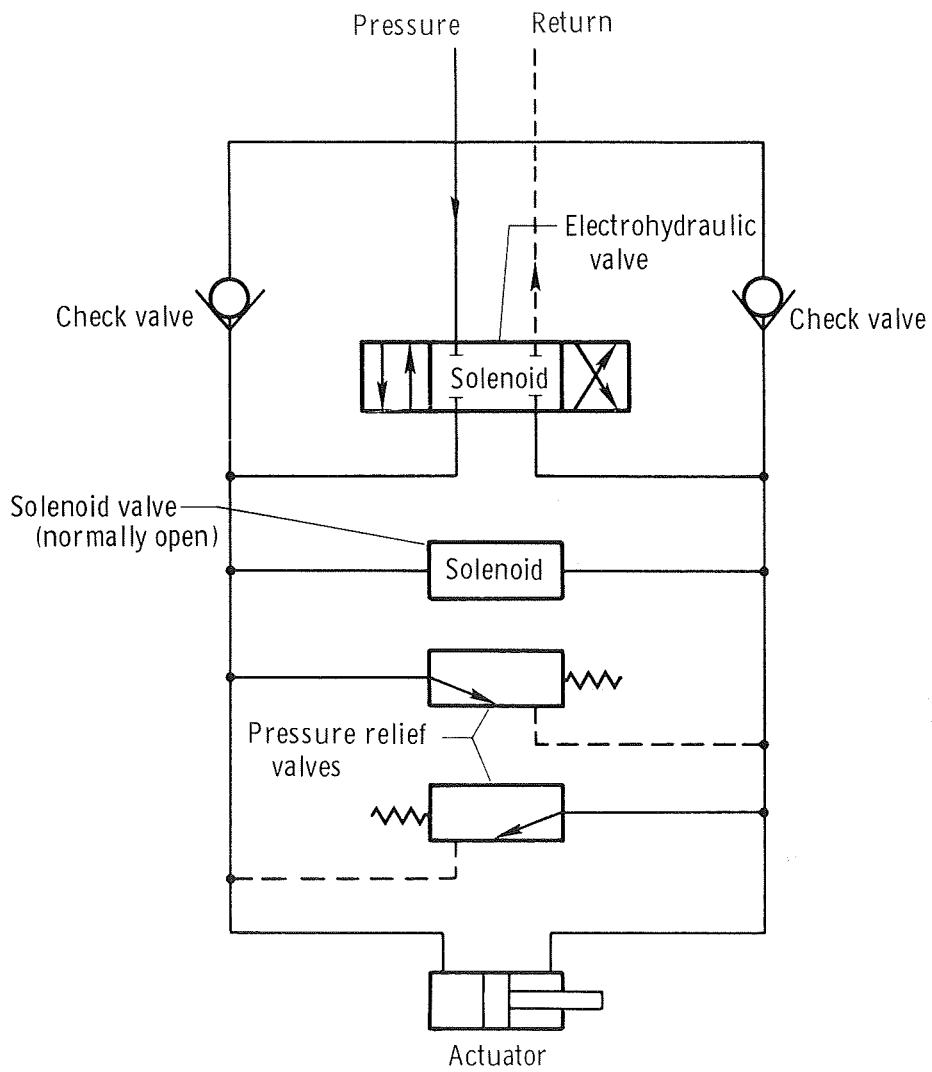
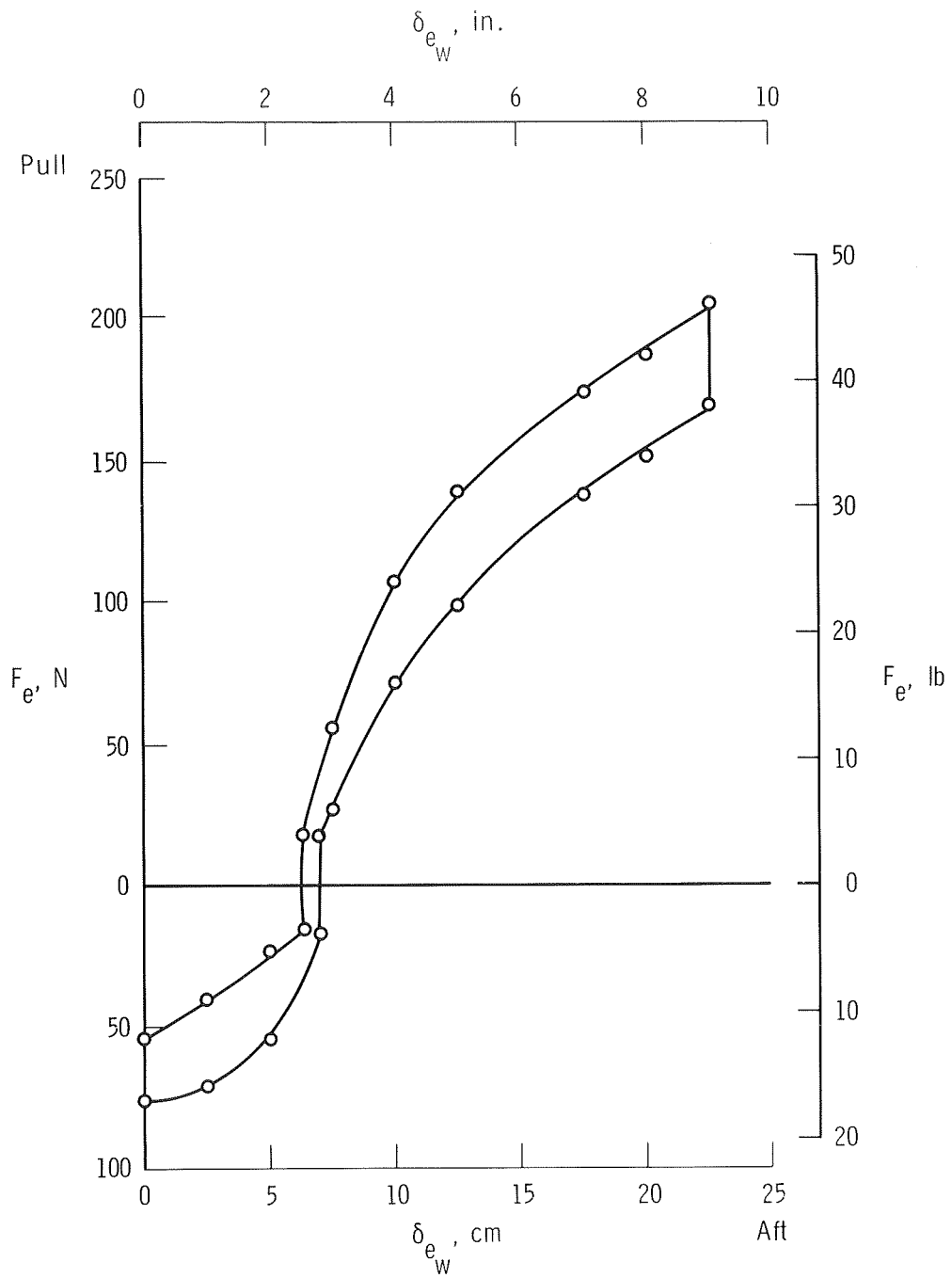
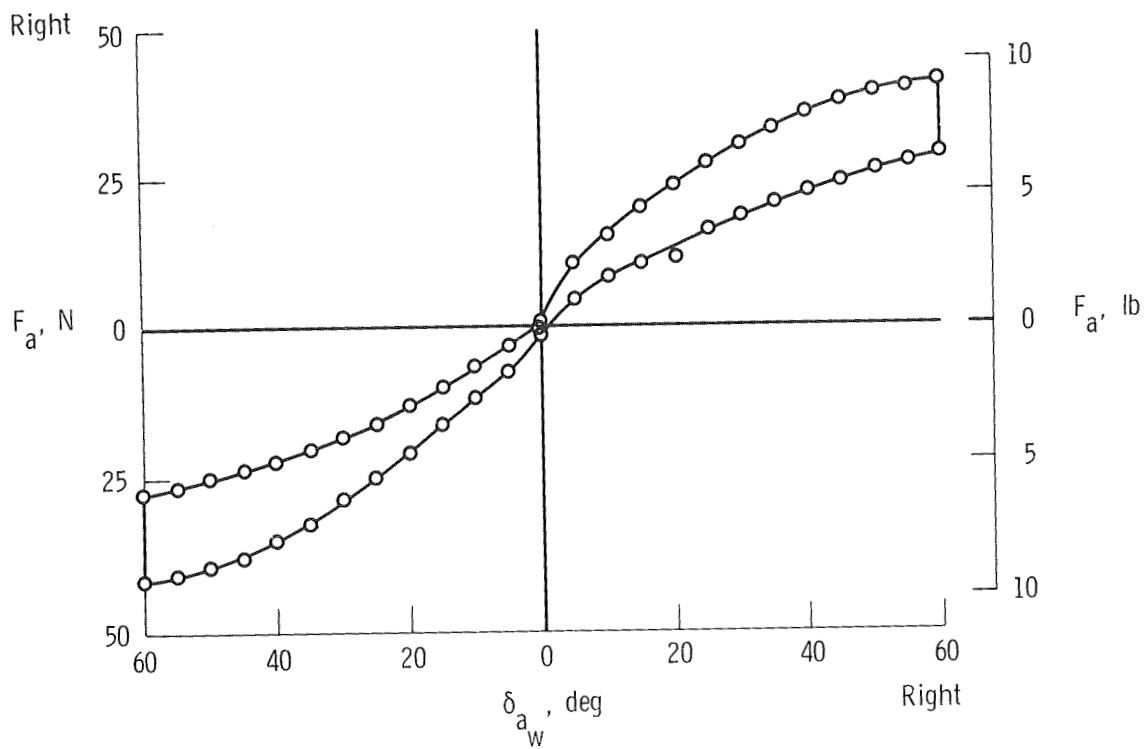

Figure 3. Servoactuator and hydraulic manifold.



(a) Elevator.

Figure 4. Artificial-feel bungee characteristics.



(b) Aileron.

Figure 4. Continued.

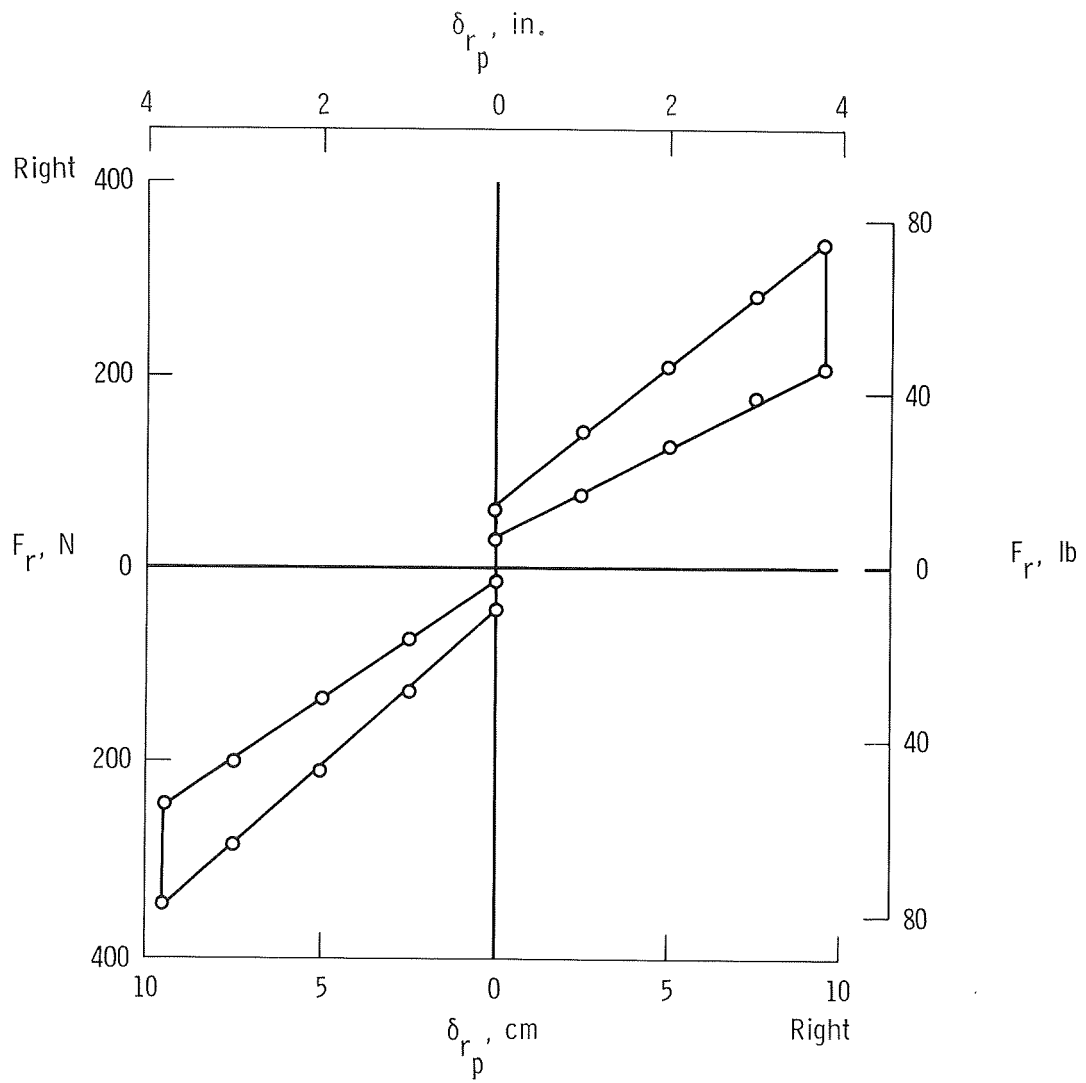

(e) Rudder .

Figure 4. Concluded .

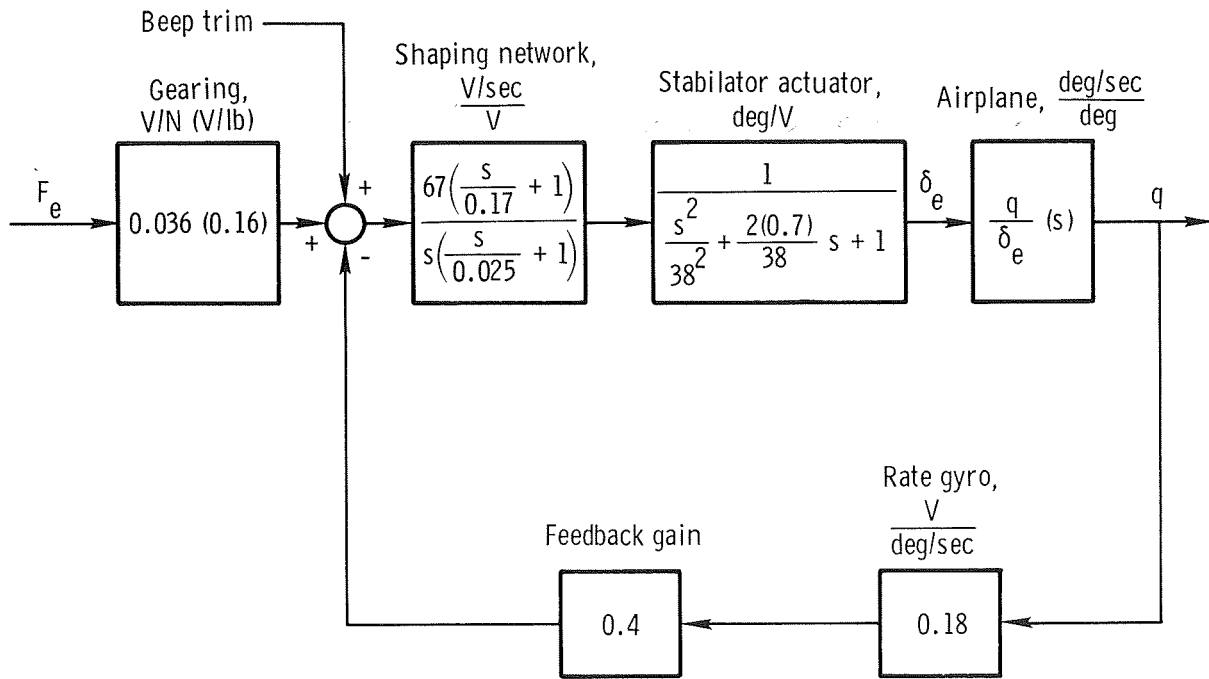

Figure 5. Pitch-rate-command control system.

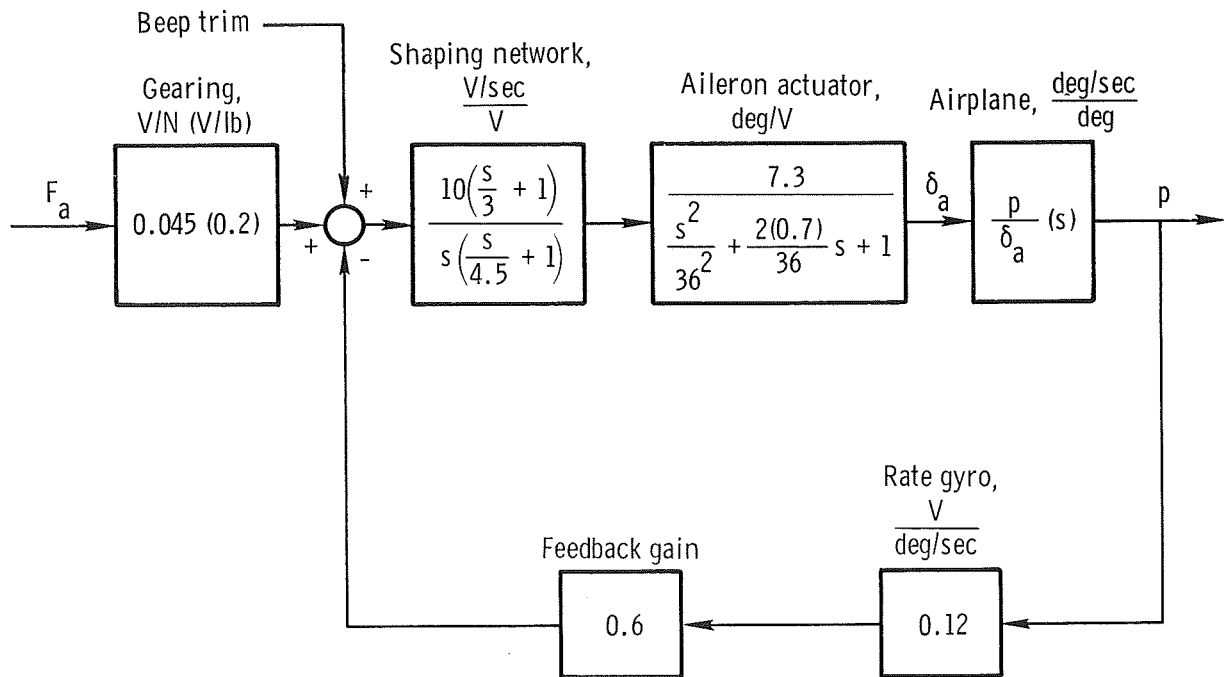

Figure 6. Roll-rate-command control system.

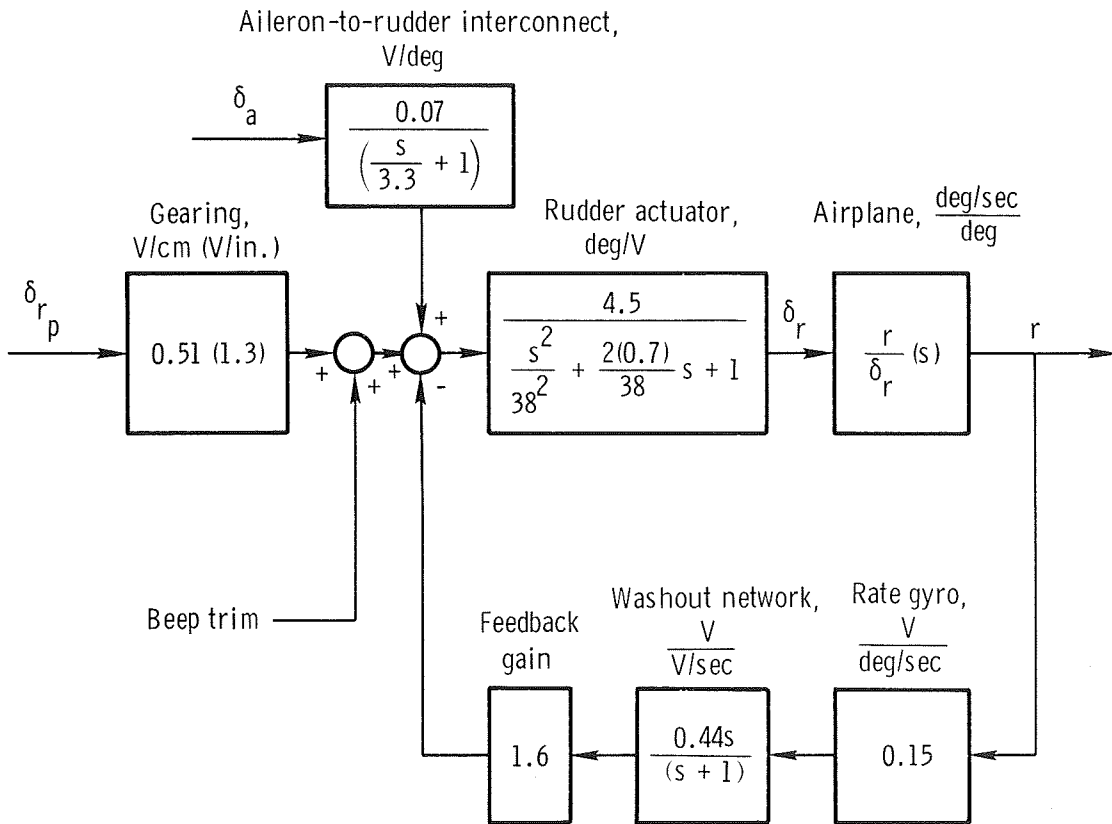

Figure 7. Yaw-rate damper and aileron-to-rudder interconnect.

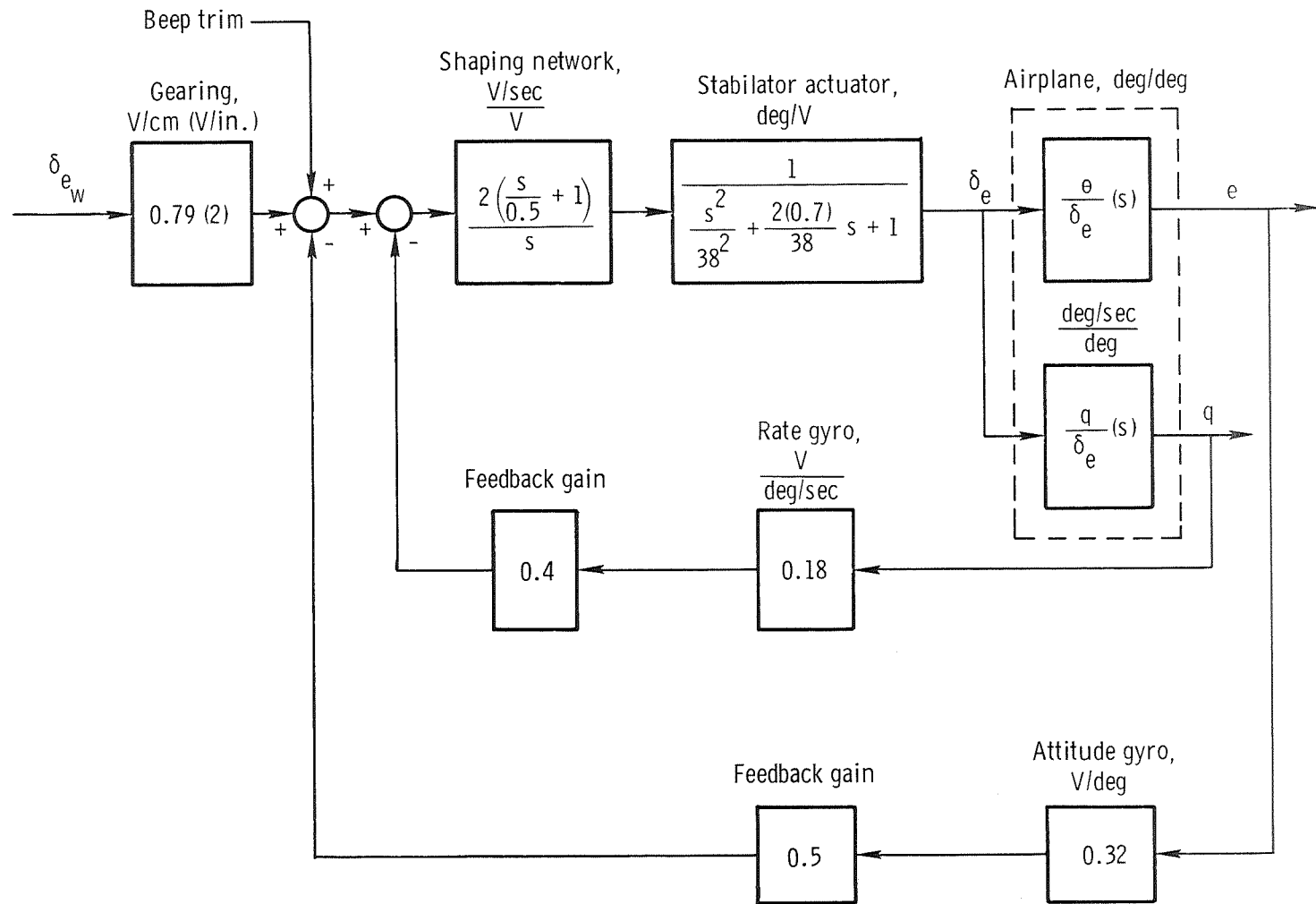

Figure 8. Pitch-attitude-command control system.

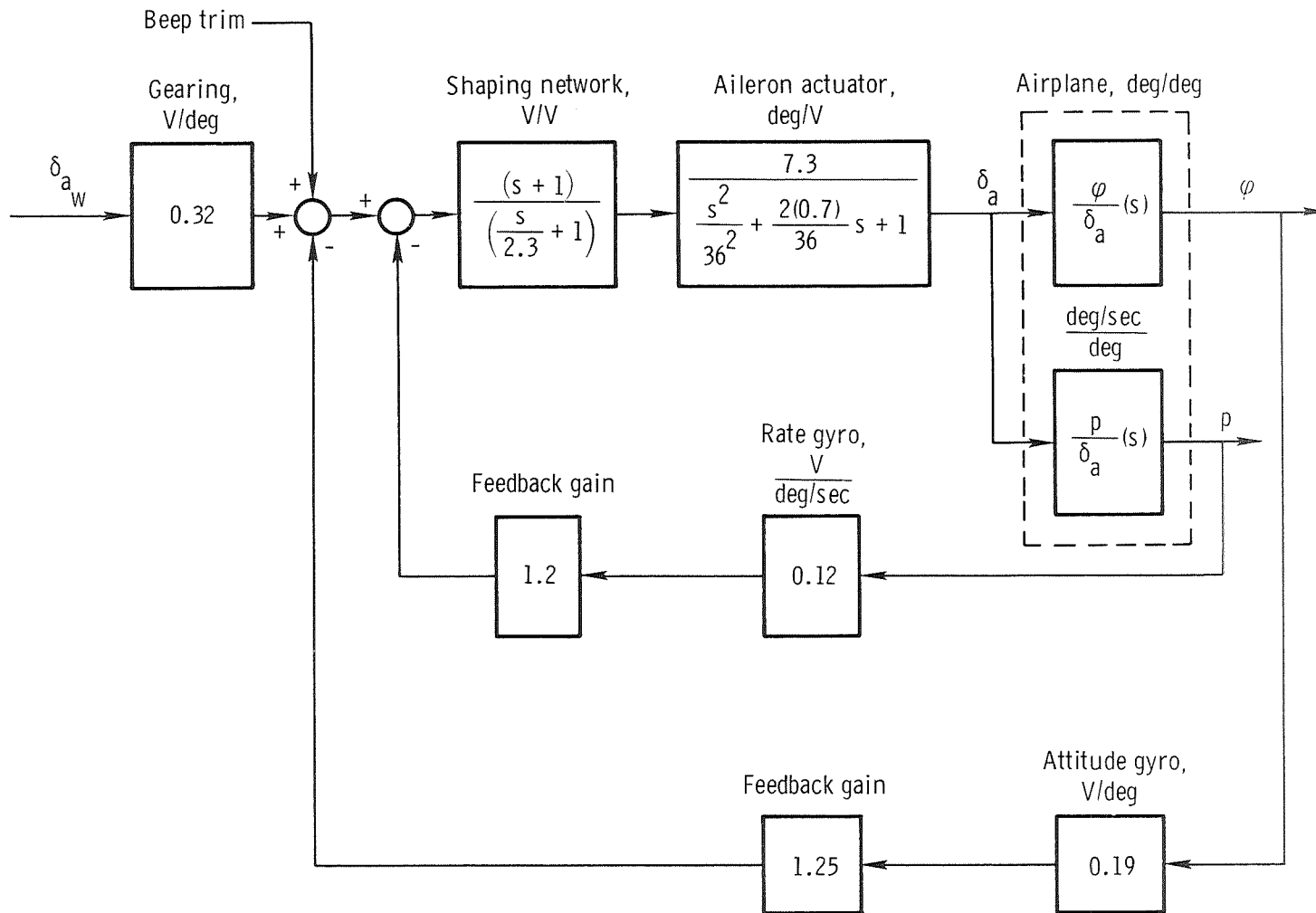
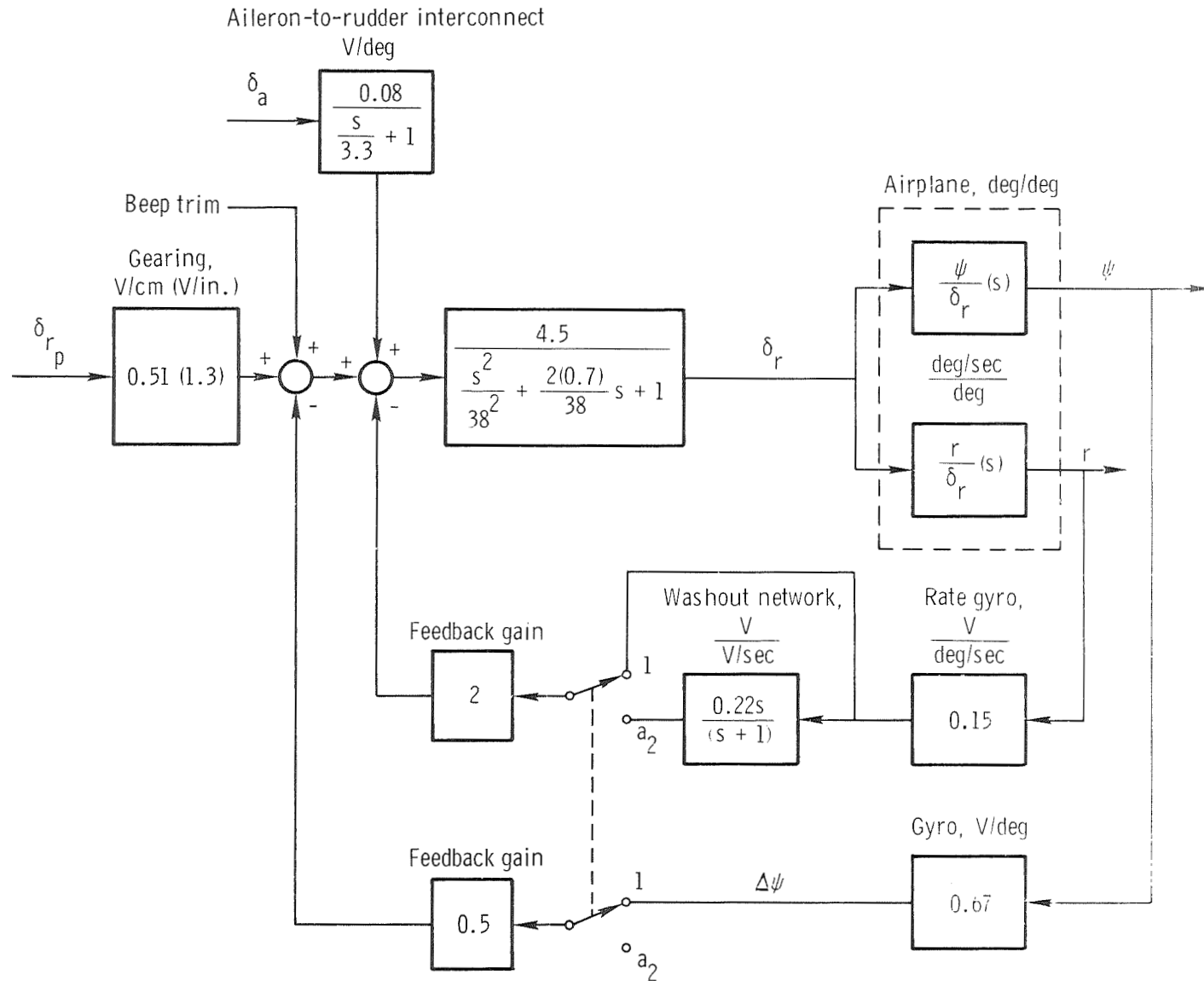
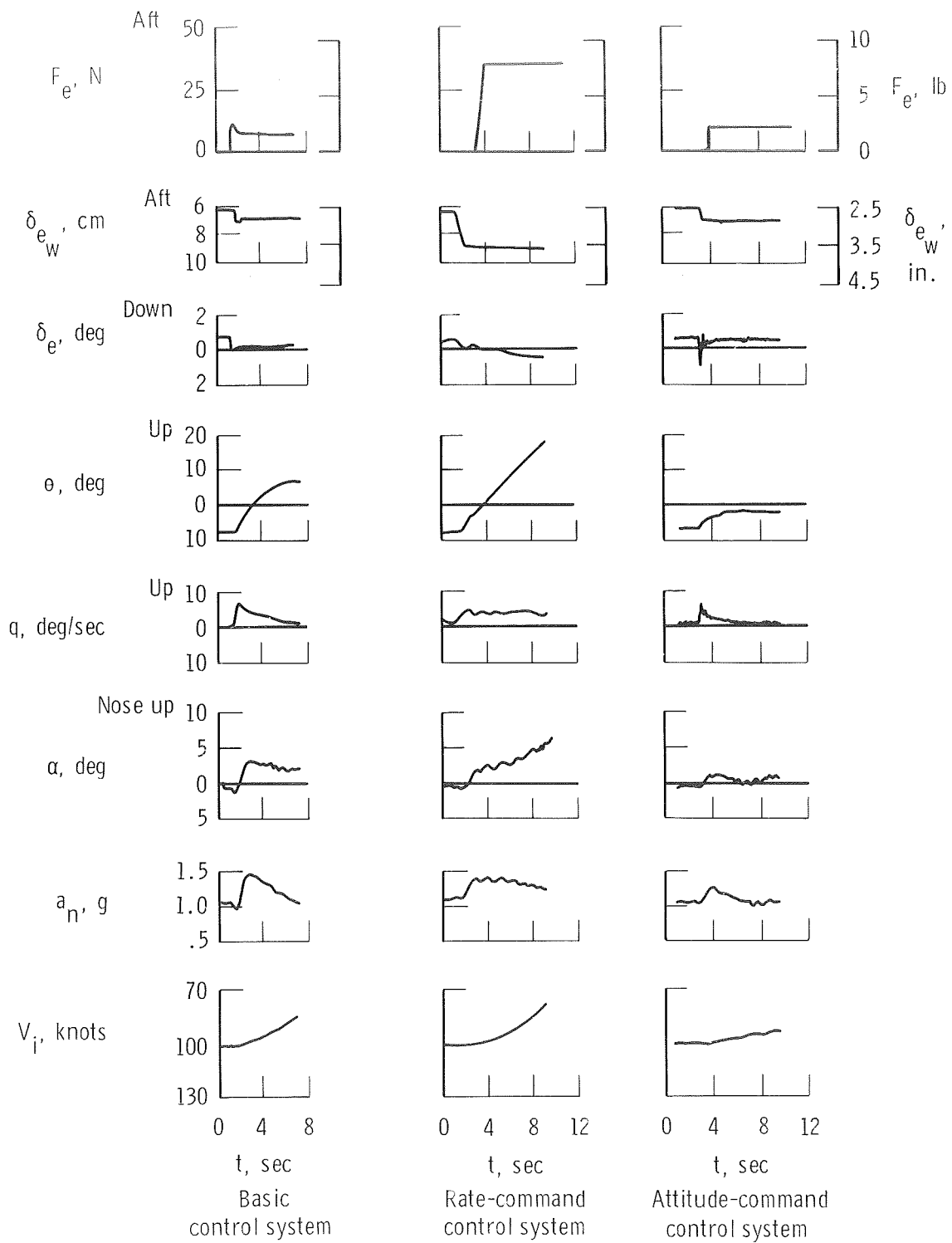

Figure 9. Roll-attitude-command control system.



^aPosition 2 when $|\psi| \geq 3^\circ$ or beep trim on or both.

Figure 10. Yaw-heading-hold system.



(a) Longitudinal response.

Figure 11. Effect of control systems on response of test airplane to step input. $V_i = 100$ knots; $\delta_f = 27^\circ$; gear down.

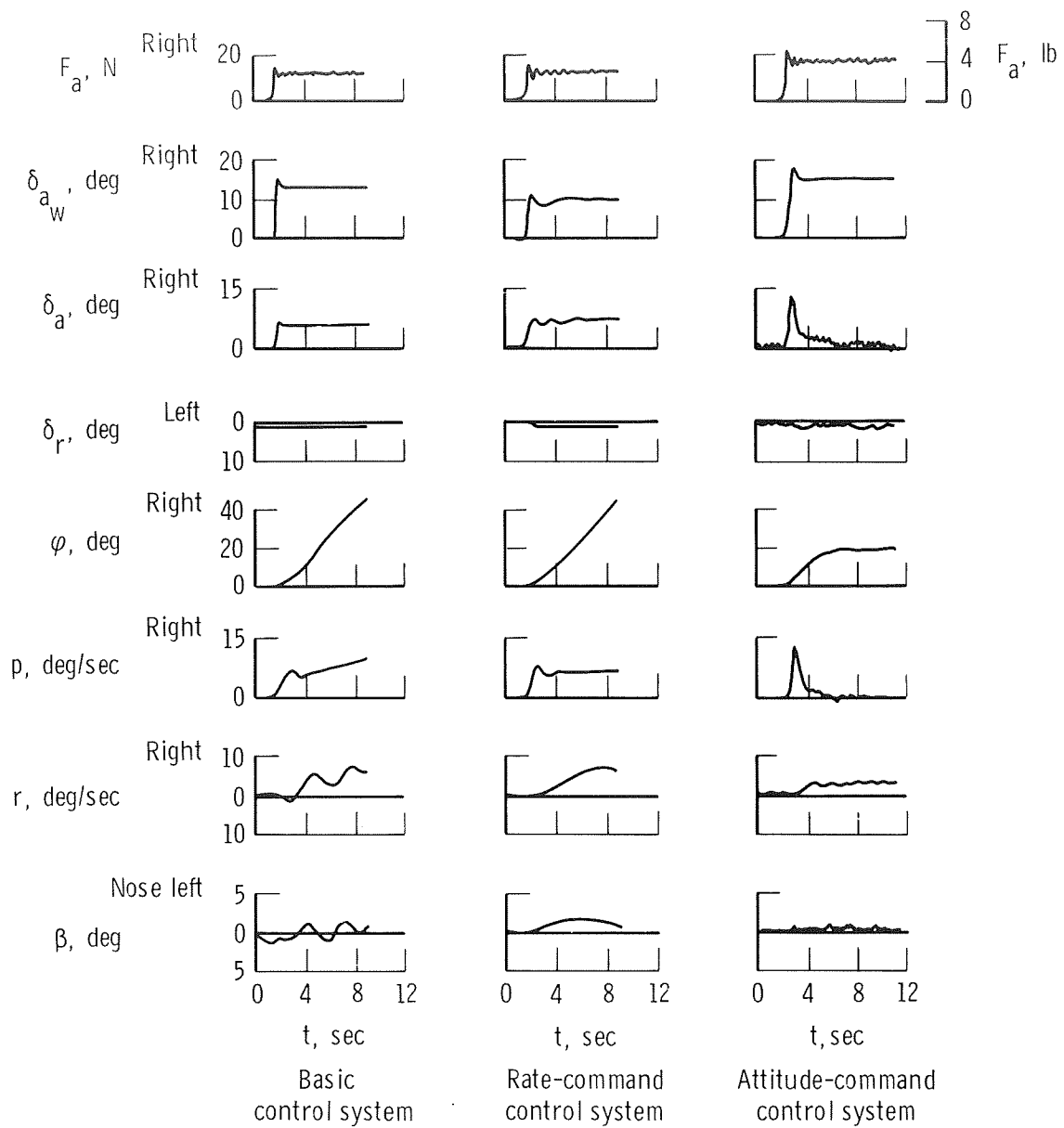

(b) Lateral-directional response.

Figure 11. Concluded.

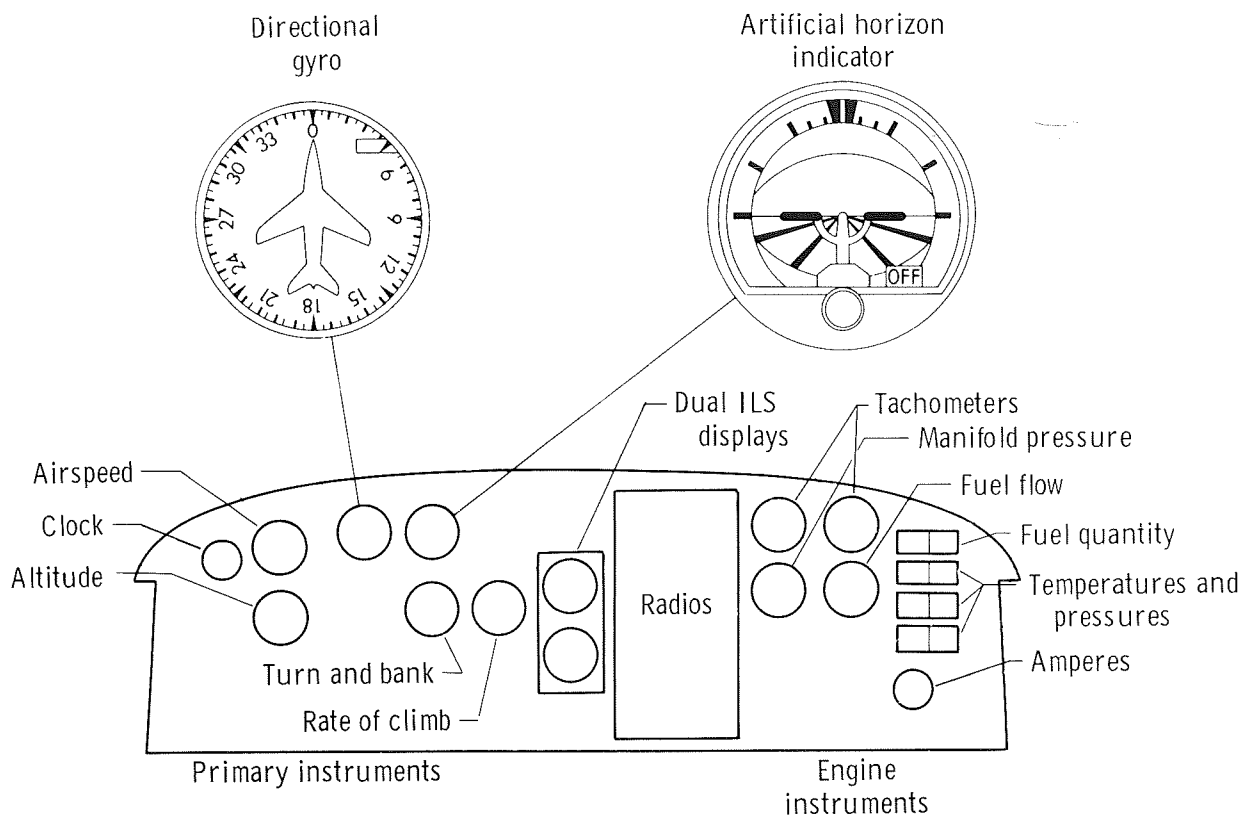

Figure 12. Basic instrument display.

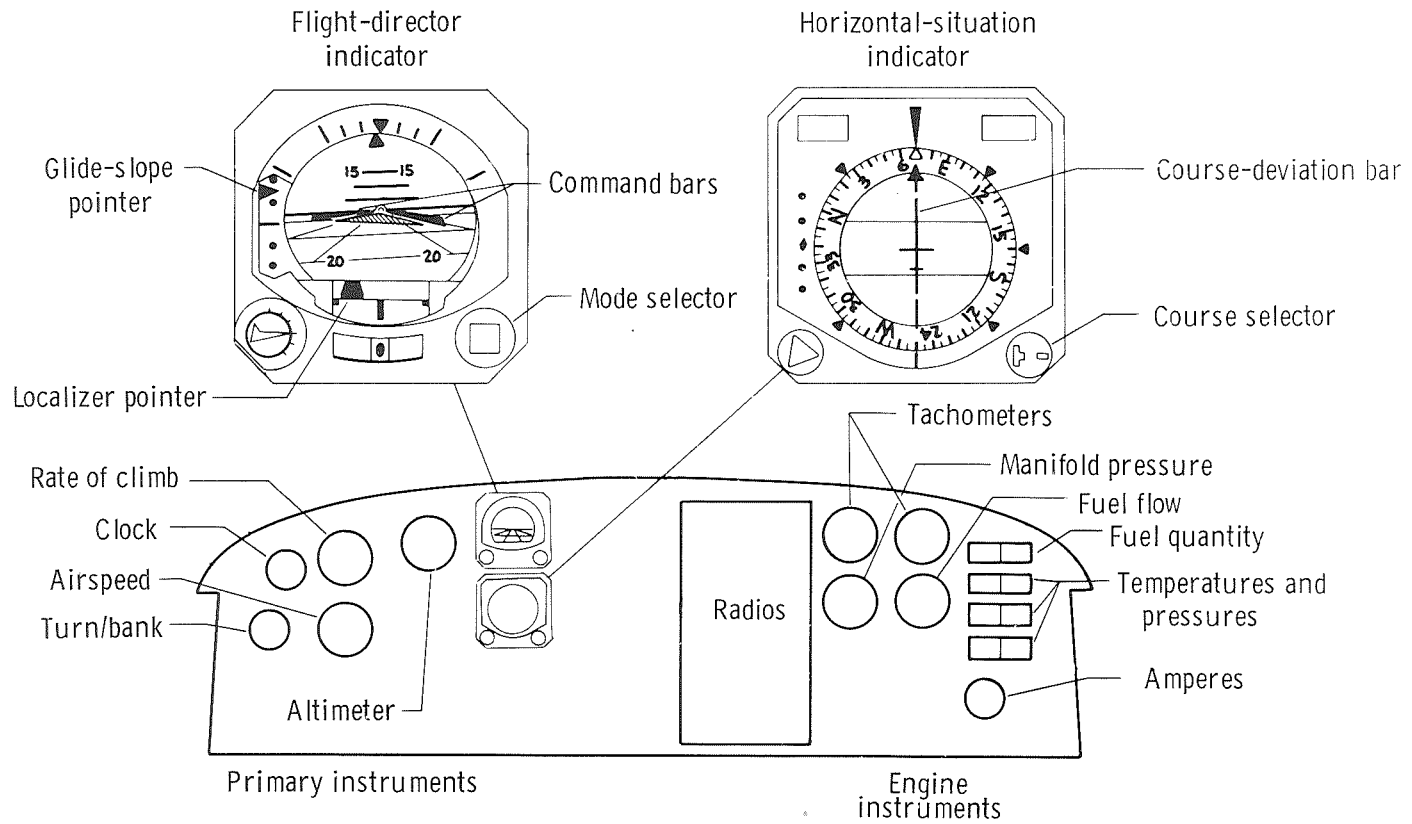

Figure 13. Flight-director display.

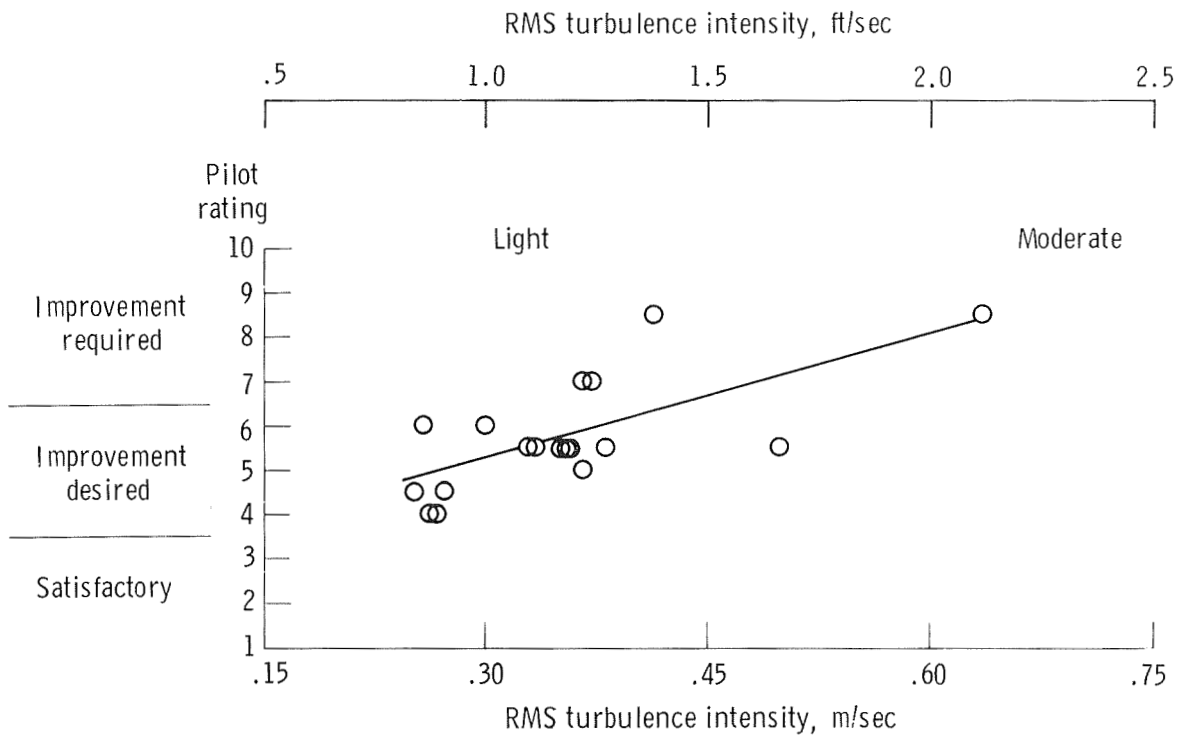

Figure 14. Pilot ratings of handling qualities for ILS approach task with basic control system.

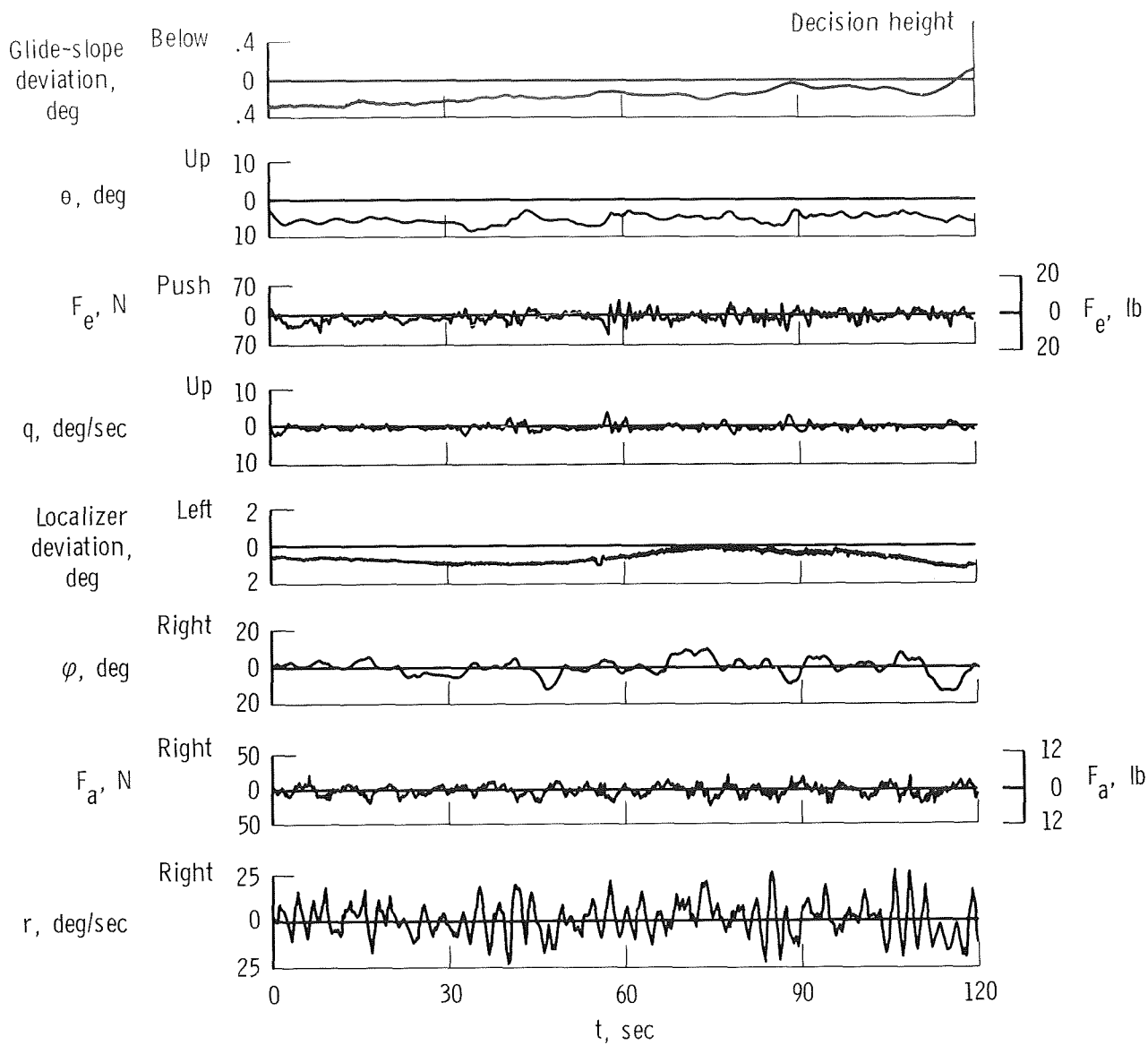

Figure 15. ILS approach in turbulence with basic control system and display.
 $V_i = 100$ knots; $\delta_f = 27^\circ$; gear down; measured turbulence = 0.44 m/sec
 (1.45 ft/sec) rms.

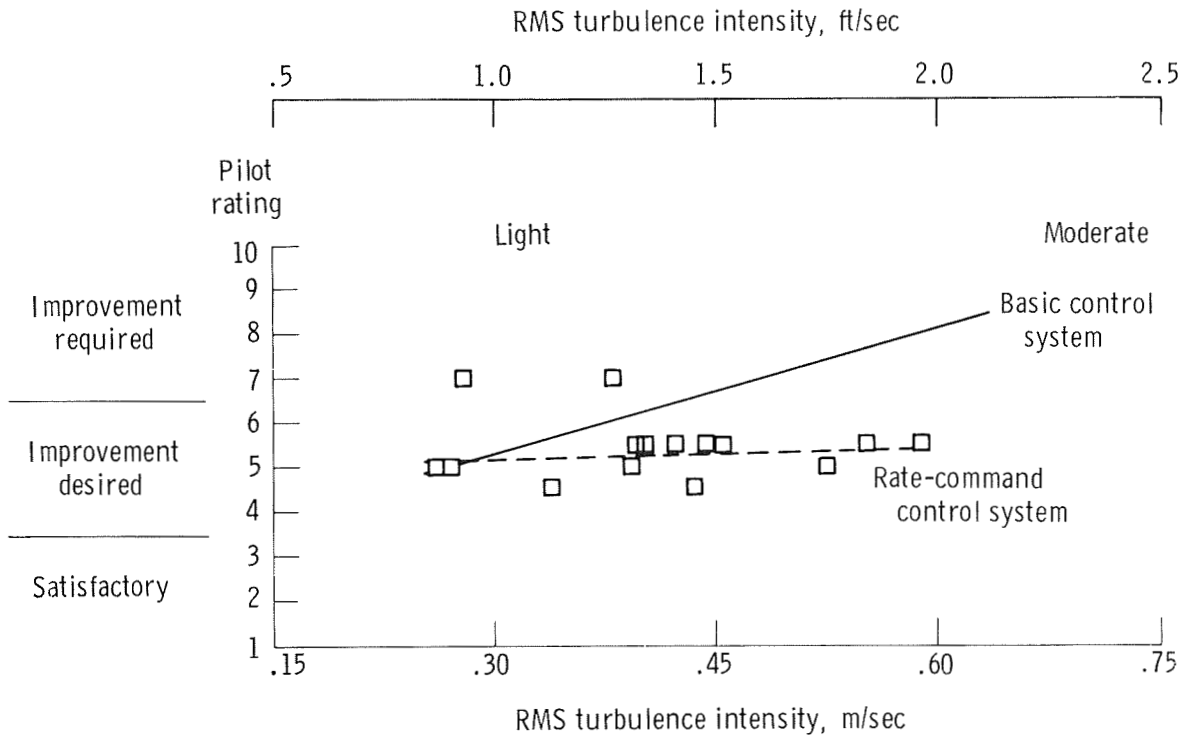

Figure 16. Pilot ratings of handling qualities of ILS approach task with basic and rate-command control systems.

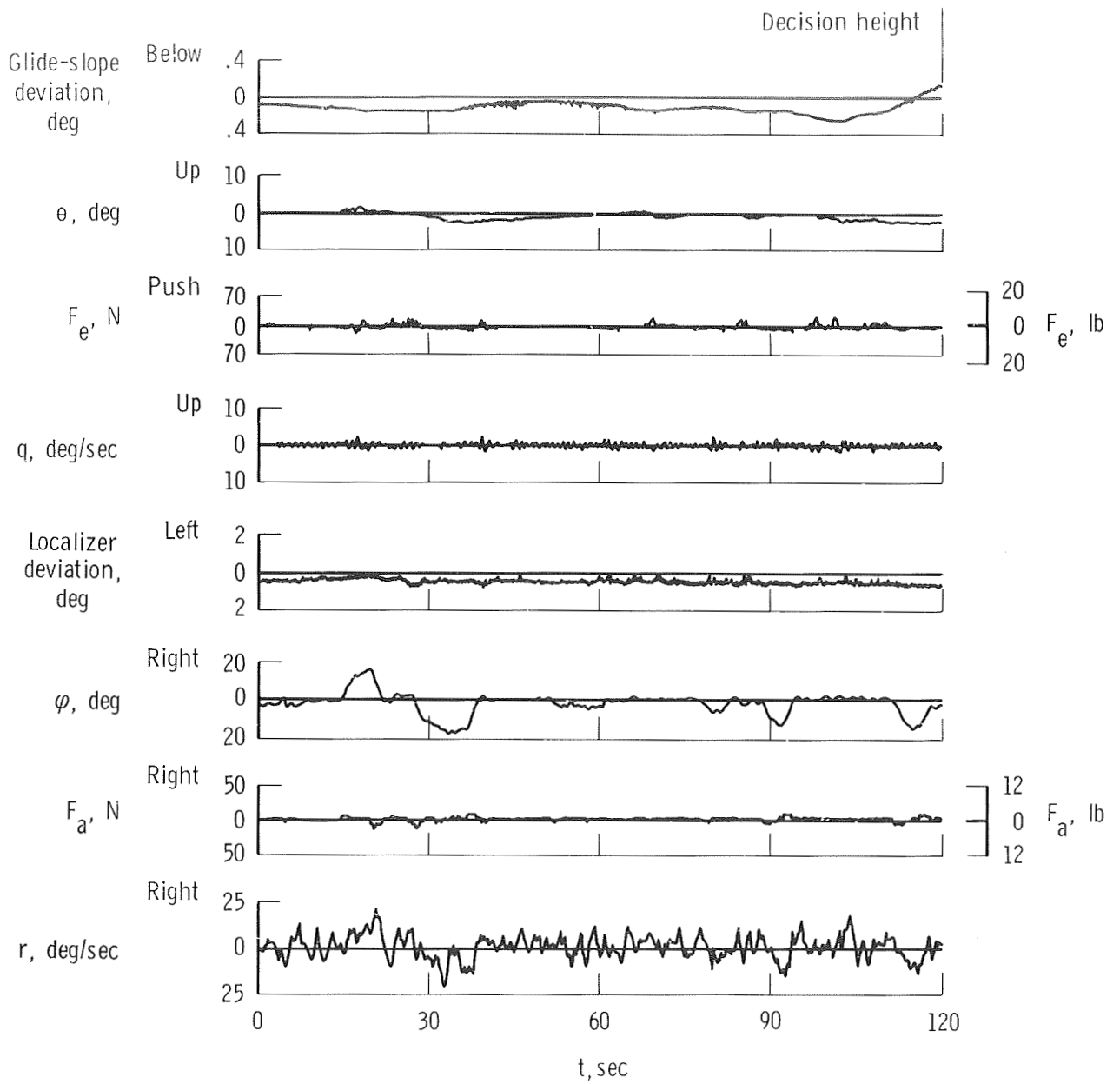

Figure 17. ILS approach in turbulence with rate-command control system and basic display. $V_i = 100$ knots; $\delta_f = 27^\circ$; gear down; measured turbulence = 0.43 m/sec (1.40 ft/sec) rms.

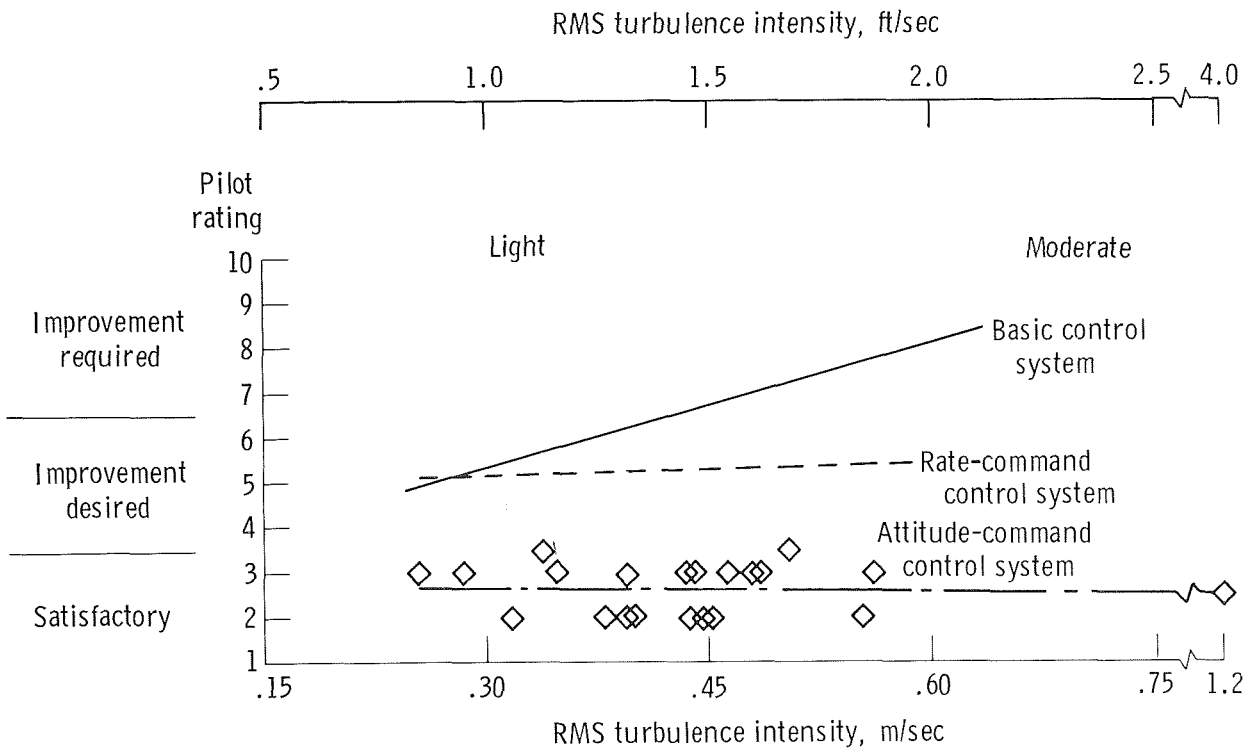

Figure 18. Pilot ratings of handling qualities for ILS approach task with basic, rate-command, and attitude-command control systems.

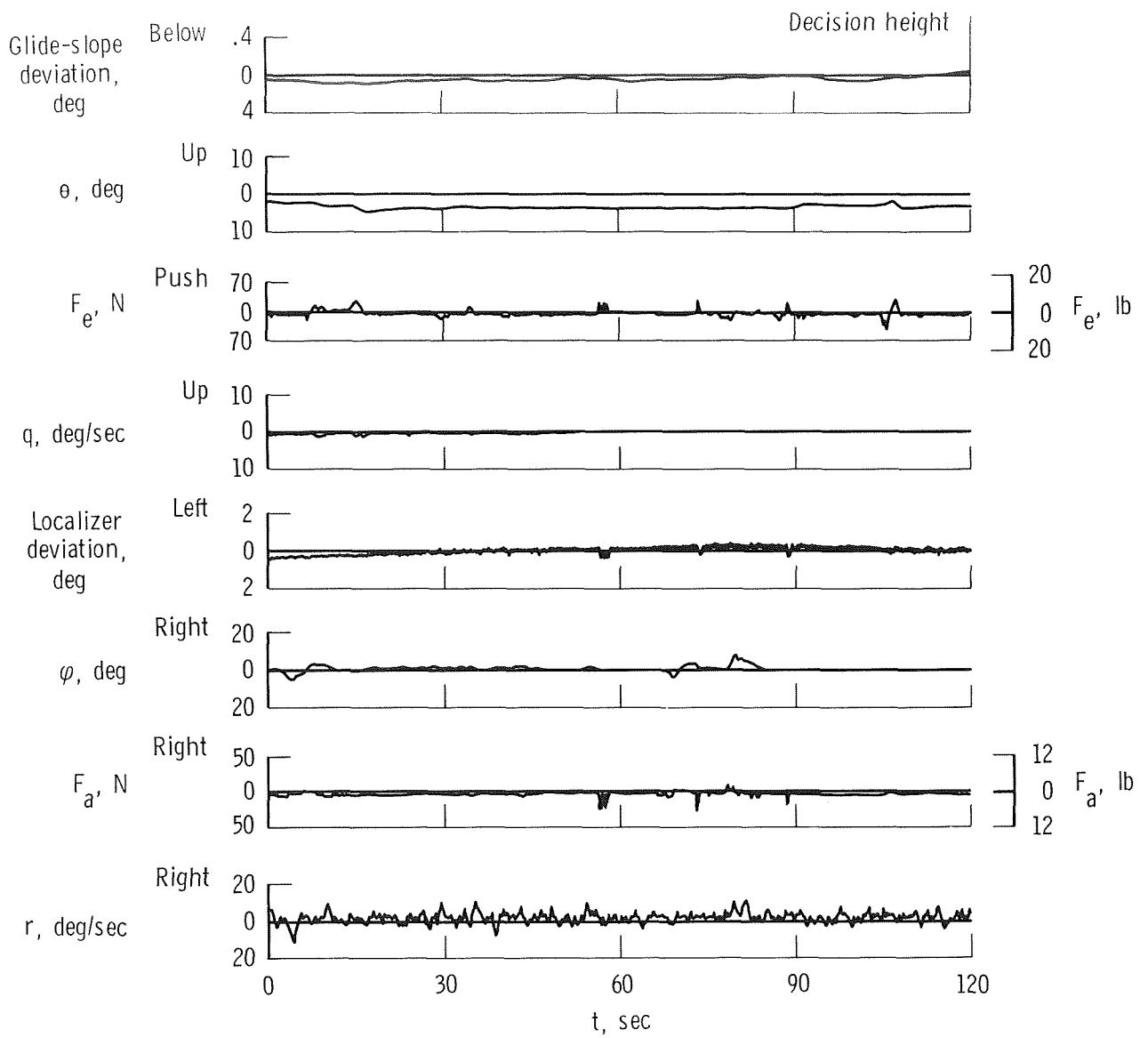

Figure 19. ILS approach in turbulence with attitude-command control system and basic display. $V_i = 100$ knots; $\delta_f = 27^\circ$; gear down; measured turbulence = 0.49 m/sec (1.60 ft/sec) rms.

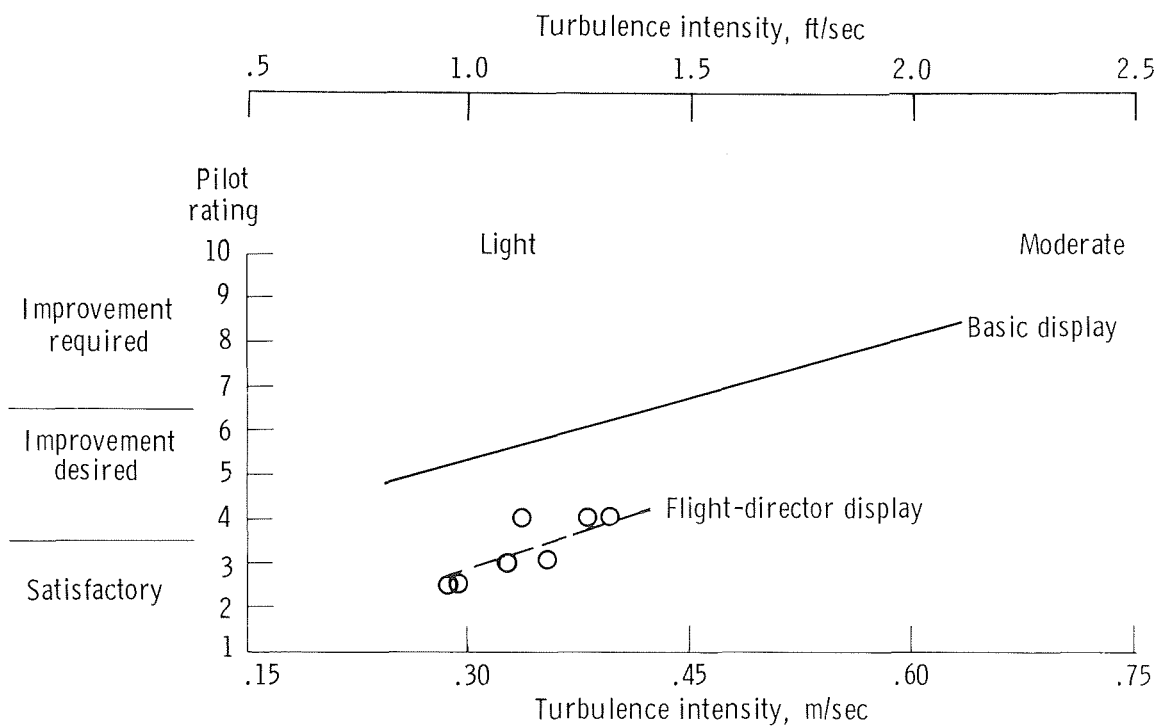

Figure 20. Pilot ratings of handling qualities for ILS approach task with basic control system with basic display and flight-director display.

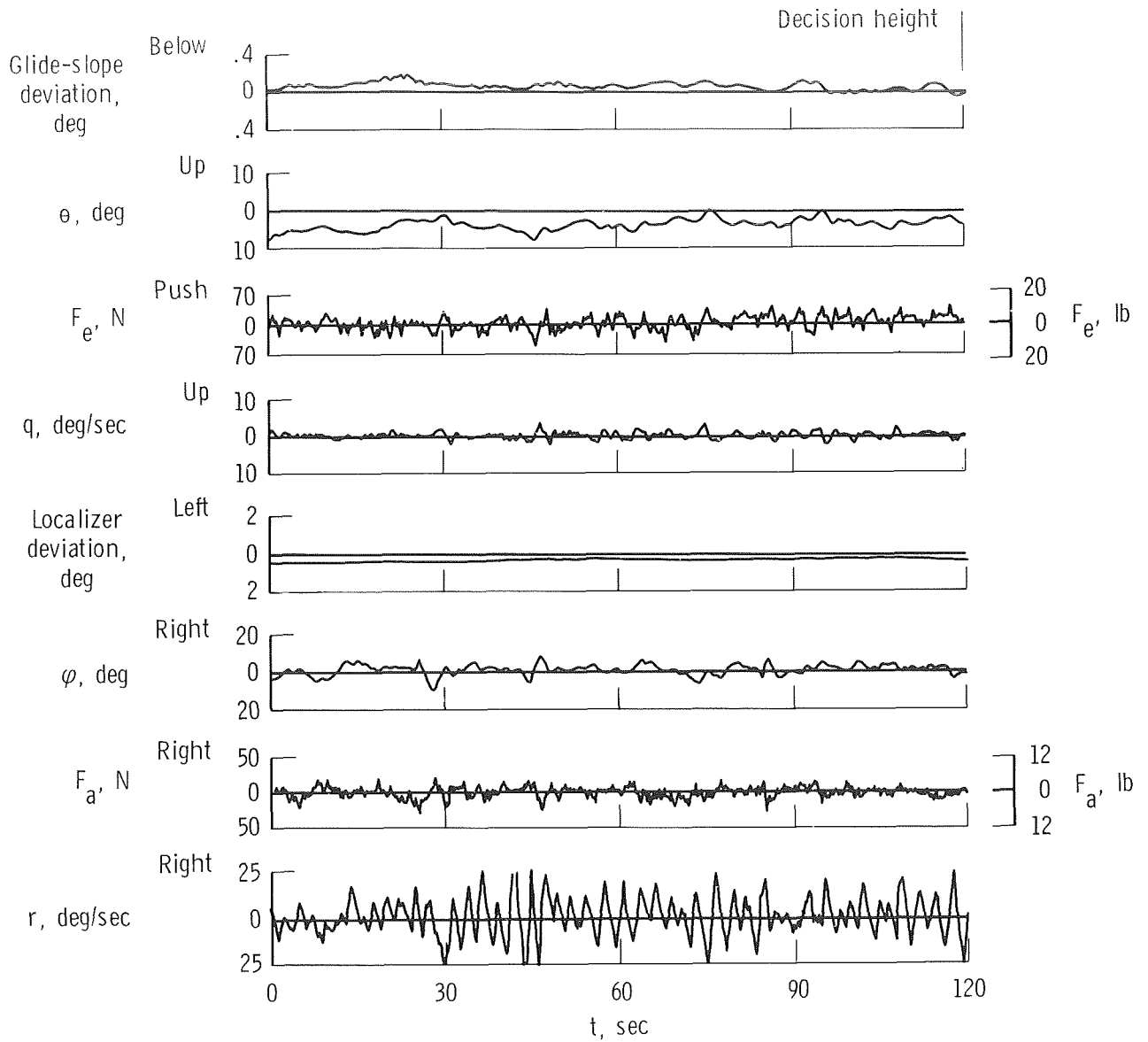

Figure 21. ILS approach in turbulence with basic control system and flight-director display. $V_i = 100$ knots; $\delta_f = 27^\circ$; gear down; measured turbulence = 0.40 m/sec (1.32 ft/sec) rms.

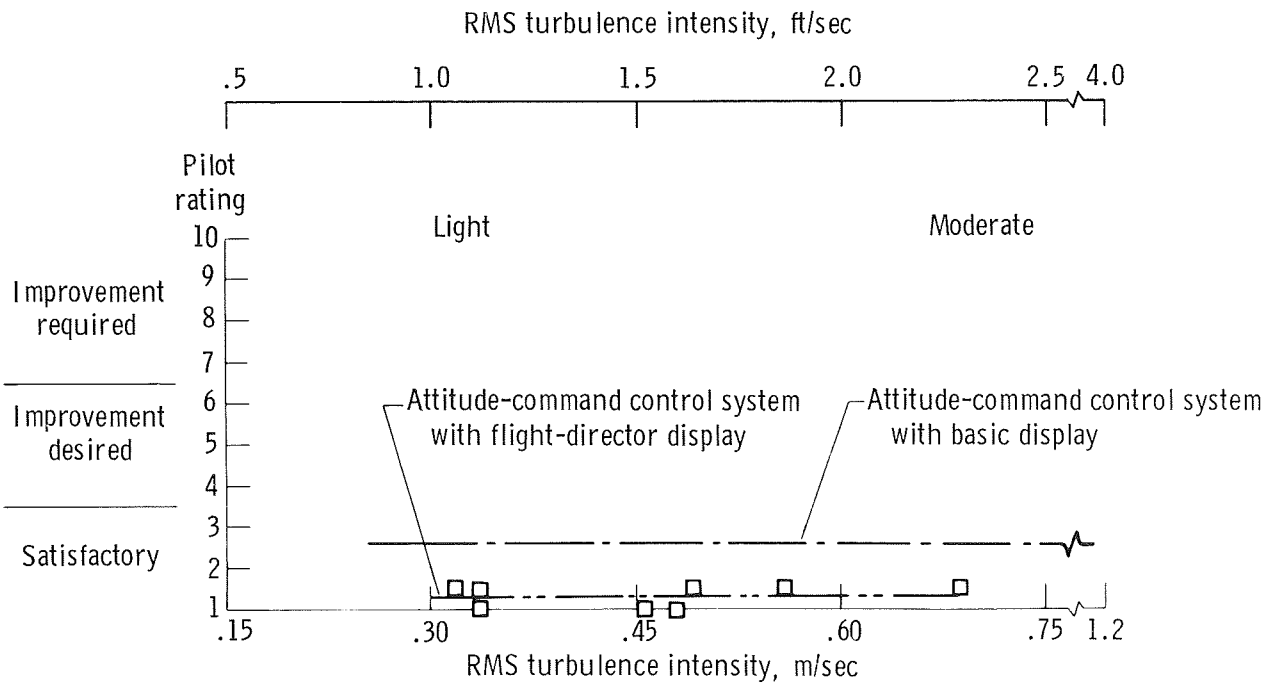

Figure 22. Pilot ratings of handling qualities for ILS approach task with attitude-command control system with basic display and flight-director display.

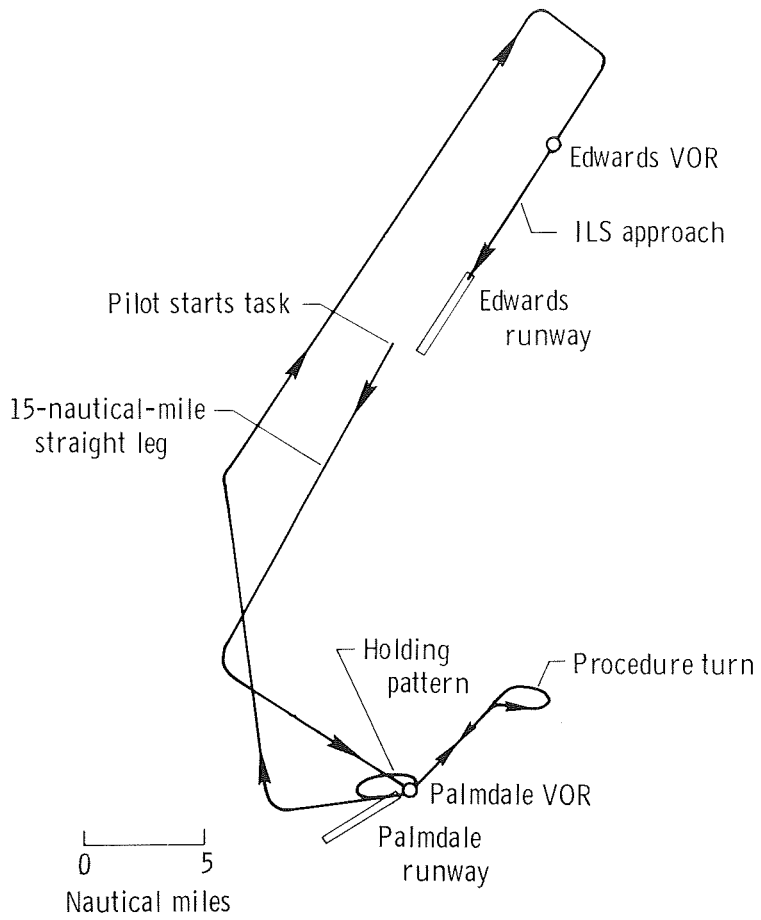

Figure 23. Pattern of IFR mission flown by noninstrument-rated pilots.

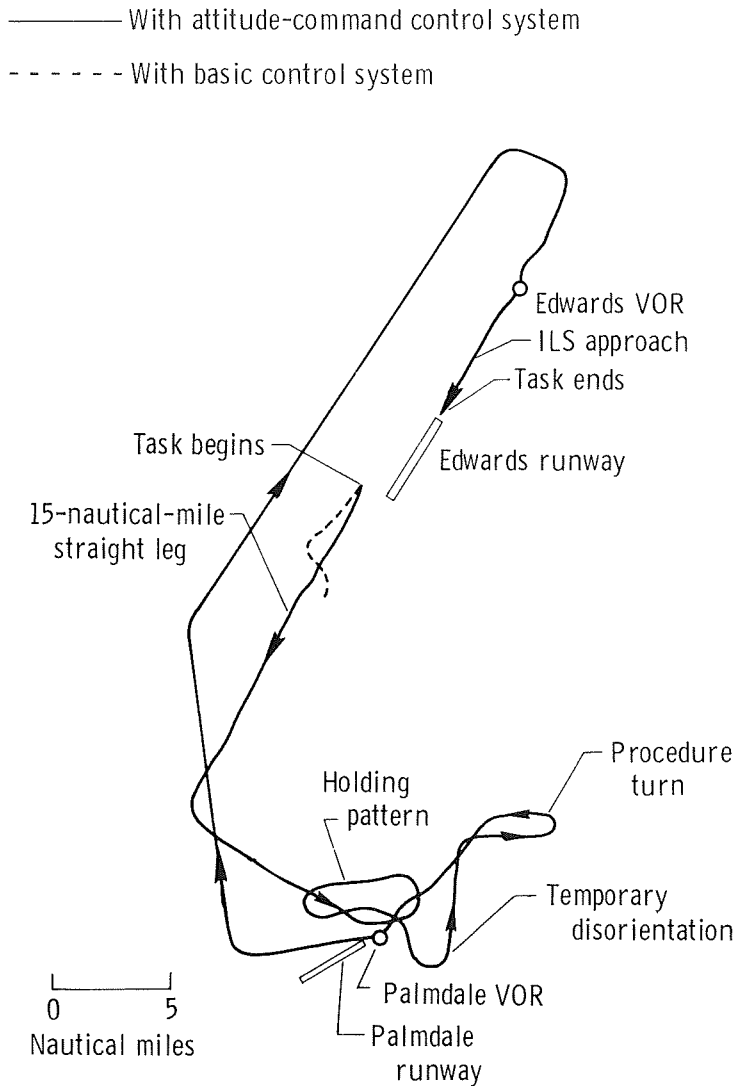

Figure 24. Performance of one VFR pilot flying the IFR mission with and without attitude-command control system.

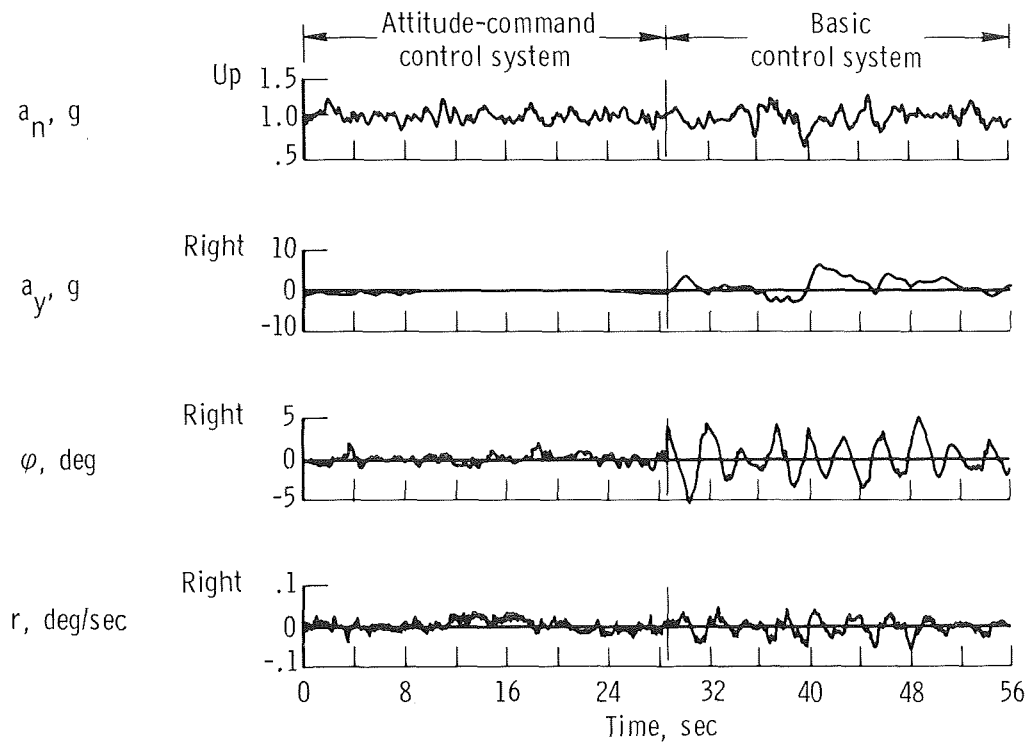

Figure 25. Comparison of airplane response to turbulence with attitude-command and basic control systems. Measured turbulence = 0.52 m/sec (1.7 ft/sec).

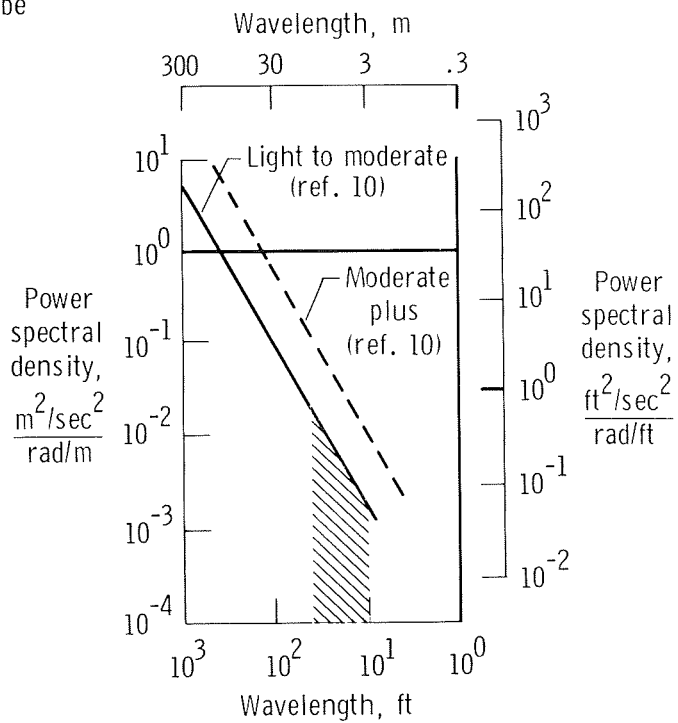
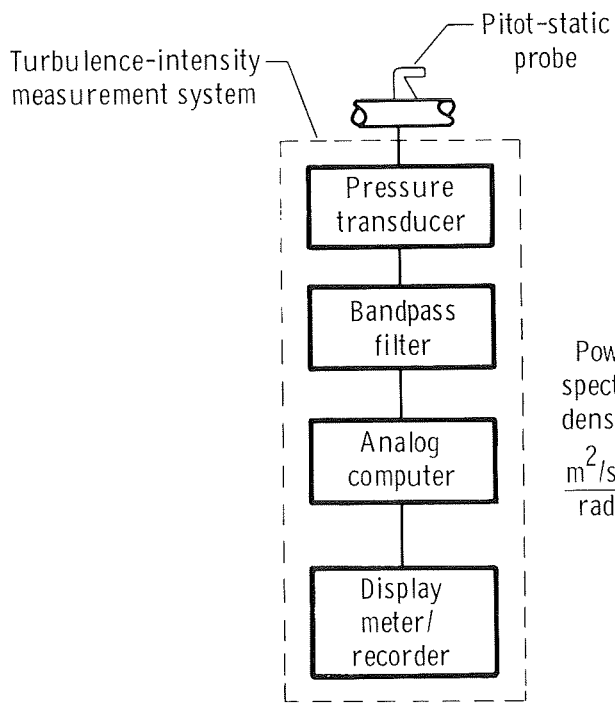

Figure 26. Turbulence-intensity measurement system.



POSTMASTER: If Undeliverable (Section 158
Postal Manual) Do Not Return

"The aeronautical and space activities of the United States shall be conducted so as to contribute . . . to the expansion of human knowledge of phenomena in the atmosphere and space. The Administration shall provide for the widest practicable and appropriate dissemination of information concerning its activities and the results thereof."

—NATIONAL AERONAUTICS AND SPACE ACT OF 1958

NASA SCIENTIFIC AND TECHNICAL PUBLICATIONS

TECHNICAL REPORTS: Scientific and technical information considered important, complete, and a lasting contribution to existing knowledge.

TECHNICAL NOTES: Information less broad in scope but nevertheless of importance as a contribution to existing knowledge.

TECHNICAL MEMORANDUMS: Information receiving limited distribution because of preliminary data, security classification, or other reasons. Also includes conference proceedings with either limited or unlimited distribution.

CONTRACTOR REPORTS: Scientific and technical information generated under a NASA contract or grant and considered an important contribution to existing knowledge.

TECHNICAL TRANSLATIONS: Information published in a foreign language considered to merit NASA distribution in English.

SPECIAL PUBLICATIONS: Information derived from or of value to NASA activities. Publications include final reports of major projects, monographs, data compilations, handbooks, sourcebooks, and special bibliographies.

TECHNOLOGY UTILIZATION PUBLICATIONS: Information on technology used by NASA that may be of particular interest in commercial and other non-aerospace applications. Publications include Tech Briefs, Technology Utilization Reports and Technology Surveys.

Details on the availability of these publications may be obtained from:

SCIENTIFIC AND TECHNICAL INFORMATION OFFICE

NATIONAL AERONAUTICS AND SPACE ADMINISTRATION

Washington, D.C. 20546