

**NASA CONTRACTOR  
REPORT**



**NASA CR-2416**

**NASA CR-2416**

**FABRICATION OF NEUROPHYSIOLOGICAL  
MONITORING SYSTEMS**

*by James D. Frost, Jr.*

*Prepared by*

**THE METHODIST HOSPITAL**

**Houston, Texas 77025**

*for Lyndon B. Johnson Space Center*



**NATIONAL AERONAUTICS AND SPACE ADMINISTRATION • WASHINGTON, D. C. • JUNE 1974**

1. Report No. NASA CR-2416		2. Government Accession No.		3. Recipient's Catalog No.	
4. Title and Subtitle FABRICATION OF NEUROPHYSIOLOGICAL MONITORING SYSTEMS				5. Report Date June 1974	
				6. Performing Organization Code	
7. Author(s) James D. Frost, Jr., M.D.				8. Performing Organization Report No.	
9. Performing Organization Name and Address The Methodist Hospital 6515 Bertner Blvd. Houston, TX 77025				10. Work Unit No. 961-50-50-89-DB	
				11. Contract or Grant No. NAS 9-13065	
12. Sponsoring Agency Name and Address National Aeronautics and Space Administration Washington, D.C. 20546				13. Type of Report and Period Covered Contractor Report - Final	
				14. Sponsoring Agency Code	
15. Supplementary Notes					
16. Abstract This report describes a system designed to collect electroencephalographic (EEG), electro-oculographic (EOG), electromyographic (EMG), and head motion data. The portable instrumentation provides a rapid and simple means by which neurophysiological data can be obtained by the patient in his home and the taped data returned to the laboratory for analysis. The system was designed primarily for the study of sleep.					
17. Key Words (Suggested by Author(s)) . Data Acquisition . Electro-oculography . Neurophysiology . Electroencephalography . Sleep . Electromyography . Fabrication . Tape Recorders . Data Processing			18. Distribution Statement STAR SUBJECT CATEGORY - 05		
19. Security Classif. (of this report) Unclassified		20. Security Classif. (of this page) Unclassified		21. No. of Pages 69	22. Price* 3.75

## CONTENTS

BACKGROUND.....	Page 1
WORK COMPLETED.....	Page 2
RESEARCH PROTOCOL.....	Page 3
GENERAL SPECIFICATIONS.....	Page 4
INSTRUCTION MANUAL MODIFICATIONS.....	Page 5
APPENDIX	
Instruction Manual for CH 104-T Neurophysiological Monitoring System.....	Page 7
Instruction Manual for CH 104 Neurophysiological Monitoring Assembly.....	Page 41

## BACKGROUND

Previous work conducted in this laboratory (NASA contracts NAS 9-10747, NAS 9-11855) resulted in the development of an onboard system to accomplish automatic sleep monitoring. This system, used on the Skylab I and II flights and currently in use on Skylab III (M133 Sleep-Monitoring Experiment), consists of data acquisition components and data processing capacity. The data acquisition scheme includes a recording cap with pre-filled sponge electrodes, a preamplifier-accelerometer assembly, and a control-panel assembly with automatic electrode-testing circuitry, power amplifiers, and analog tape recorders. The acquisition system outputs two channels of electroencephalographic (EEG) activity, one channel of electro-oculographic (EOG) activity, and one channel of electromyographic (EMG) activity representative of head motion detected by an accelerometer mounted on the recording cap. A special-purpose onboard computational device processes these signals and produces an output indicative of the test subject's current level of sleep.

The data acquisition portion of the M133 system has been specifically designed to operate under adverse environmental conditions. The preparation procedures required are very simple, and no special training is necessary. Time requirements are minimal; usually no more than two to three minutes are needed prior to a recording session. The electronic configuration has been developed to insure a high degree of reliability, safety, and rejection of extraneous signals. These features, although designed specifically for space flight, are highly desirable for monitoring in other situations.

Limited trials of flight-type equipment have shown that data of good quality may be obtained under conditions that ordinarily would severely limit, or even prevent, successful use of conventional recording equipment. For example, EEG monitoring is of considerable importance in detecting certain complications during open-heart surgery; conventional equipment is too cumbersome to permit routine use, but the system developed in this laboratory has been used successfully to obtain such recordings. Similarly, monitoring has been conducted in cardiac intensive care units where, in addition to space limitations, the ability to record for extended periods is essential.

The equipment's portability has also permitted recording to be carried out in a subject's own home (baseline studies for Apollo and Skylab astronauts), and this capability has been extended to monitoring selected patients in their own homes, thereby saving them the expense of hospitalization.

Use of the apparatus described above has thus far been very limited because of the few existing units and their commitment to the Skylab program. The contract permitted construction of nine monitoring systems, thereby allowing evaluation of their suitability in a wide range of situations. Economical production of these additional units required a number of design changes. For example, the magnetic tape recorders had to be procured from a different supplier, since the previously used Gemini-type recorders (Cook Electric Company, MSC-REC-SYS-GF-C1) were no longer manufactured, and they presented technical problems during playback which made them unsuitable for our purposes had they been available.

#### WORK COMPLETED

The Contractor utilized the general concepts and designs previously developed for the Skylab M133 Sleep-Monitoring System in creating the neurophysiological-monitoring systems described below. Specific design alterations were undertaken only when necessary to make hardware suited to ground-based uses. The following items were delivered:

I. Five (5) each Neurophysiological Monitoring Systems, each consisting of the following components:

One (1) sleep-monitoring cap containing prefilled sponge electrodes in the Skylab M133 configuration

One (1) preamplifier containing necessary elements to record EEG, EOG, EMG, and head motion

One (1) control panel assembly including:

- a. power amplifiers
- b. power supplies
- c. automatic electrode-testing circuitry
- d. magnetic tape recorder (4-channel) for preserving EEG, EOG, EMG and head motion signals. Recorders shall be capable of at least 8 hours of continuous operation without tape change
- e. output interface to drive external recording device

- II. Four (4) each Neurophysiological Monitoring Assemblies, each assembly consisting of the following components:
- One (1) sleep-monitoring cap containing prefilled sponge electrodes in the Skylab M133 configuration
  - One (1) preamplifier containing necessary elements to record EEG, EOG, EMG, and head motion
  - One (1) control panel assembly including:
    - a. power amplifiers
    - b. power supplies
    - c. automatic electrode-testing circuitry
    - d. output interface to drive external recording device
- III. Nine (9) each Preamplifier-Accelerometer Assemblies containing necessary elements to record EEG, EOG, EMG and head motion
- IV. One hundred and ten (110) each Recording Caps containing sponge electrodes as follows:
- a. 45 each configuration suitable for recording a single channel each of EEG, EOG, EMG, and head motion
  - b. 65 each Skylab M133 configuration (2 channels EEG, 1 EOG, 1 head motion)
- V. Complete documentation including schematics, operating instructions, and schematics for each of the nine (9) neurophysiological monitoring systems.

## RESEARCH PROTOCOL

The contract period was divided into several phases. Phase I involved the design and construction of a prototype neurophysiological monitoring system, Phase II covered extensive testing of the prototype under laboratory and nonlaboratory conditions, Phase III dealt with finalization of prototype design and verification of it, and Phase IV encompassed construction of the nine (9) monitoring systems and additional preamplifiers and caps for delivery to NASA.

## GENERAL SPECIFICATIONS

### 1. Recording Caps

These units are essentially the same as those described in the final reports for Contracts NAS 9-10747 and NAS 9-11855. These disposable recording caps contain miniaturized, flexible sponge electrodes that have been prefilled with an electrolyte solution. The electrodes, attached inside the elastic spandex cap, are joined by wires to a miniature connector at the vertex which permits rapid linkage with the preamplifier assembly. The cap contains seven electrodes. In one configuration, four electrodes provide two EEG channels ( $C_1O_1$  and  $C_2O_2$ ), two provide one EOG channel (one lateral to and one above the left eye), and one serves as a ground. In the other configuration, two electrodes provide one EEG channel ( $C_1O_1$ ), two provide one EOG channel as before, two located in the chin strap provide one EMG channel, and one acts as ground.

### 2. Preamplifier-Accelerometer Assemblies

Detailed specifications of these units are supplied in Final Report, Contract NAS 9-10747. Matched pairs of field-effect transistors are used within this unit to provide a gain of approximately 10 for the EEG, EMG, and EOG signals. A dual-axis accelerometer and associated preamplifier are also included in this unit for detecting head motion in the lateral (side-to-side) and vertical (up-down) axes. Amplified signals from the preamplifier-accelerometer assembly pass through a 4-foot flexible cable to the control panel assembly.

### 3. Control Panel Assembly

This circuitry accomplishes electrode testing and signal amplification and provides outputs to the self-contained analog tape recorders and outputs to drive the external recorders.

The electrode-test section of the control panel assembly performs automatic testing of each recording electrode before the sleep period begins. The front panel, readily visible to the subject in the sleep compartment while he is applying the cap, contains a series of indicator lamps, each representing one sponge electrode sensor in the cap. The lamps are arranged in a configuration simulating their relative position on the head. When the subject dons the cap he moves the mode-selection switch from the off to the

test position, thereby activating the test circuitry. A small test current passes through the single ground electrode to each of the six recording electrodes, and the amount of current passed by each electrode is sensed to provide an indication of inter-electrode resistance. If a given electrode is in proper scalp contact, its resistance will be 50,000  $\Omega$  or less, and this condition is indicated by illumination of the corresponding lamp on the panel display. Improper contact, indicated by failure of any lamp to illuminate, usually can be resolved by slightly rocking the sensor to position the electrode tip through the hair and against the scalp.

A number of changes were made in the design of this unit because of the necessity to use a different analog tape recording system. The system described for the M133 Experiment (see Final Report, Contract NAS 9-10747) utilized the Gemini type 7-channel magnetic tape recorder (Cook Electric Co., MSC-REC-SYS-GF-C1). Since these units were no longer commercially available, and also presented problems in data playback, the control panel assembly had to be reconfigured to accommodate a suitable FM-type recorder (the Tandberg model Series 100).

#### INSTRUCTION MANUAL MODIFICATIONS

There were no hardware modifications made between the time the preliminary instruction manuals for the CH104 Neurophysiological Monitoring Assembly and the CH104-T Neurophysiological Monitoring System were written and distributed with the units delivered and the writing of the Final Report. However, it was felt desirable to elaborate briefly upon the section describing the amplification circuitry in both manuals. Therefore, included with the Final Report are substitute title pages and page threes for each of the manuals delivered prior to the Final Report. Persons working with the units would be advised to replace the original page with these substitutes at their convenience.



APPENDIX

INSTRUCTION MANUAL FOR CH 104-T  
NEUROPHYSIOLOGICAL MONITORING SYSTEM

and

INSTRUCTION MANUAL FOR CH 104  
NEUROPHYSIOLOGICAL MONITORING ASSEMBLY

INSTRUCTION MANUAL FOR  
CH104-T NEUROPHYSIOLOGICAL MONITORING SYSTEM  
(Final)

Prepared in accordance with Contract NAS 9-13065

## CONTENTS

I.	GENERAL DESCRIPTION OF UNIT . . . . .	11
	Recording Cap . . . . .	11
	Electrode Placement . . . . .	12
	Preamplifier, Accelerometer, and Control Panel. . . . .	12
	Circuitry. . . . .	13
II.	SPECIFICATIONS . . . . .	15
	Preamplifier . . . . .	15
	Tandberg Series 100 Tape Recorder . . . . .	15
	Modifications of Tandberg . . . . .	16
	Magnetic Tape . . . . .	16
III.	CONDUCTING A RECORDING SESSION . . . . .	17
	Preliminary Preparation . . . . .	17
	EEG or EMG Mode . . . . .	17
	Final Preparation . . . . .	18
	Use of EMG Cap . . . . .	18
IV.	INSTRUCTIONS FOR PLAYING BACK DATA . . . . .	20
V.	MAINTENANCE . . . . .	21
	Storage and Care of Recording Caps . . . . .	21

Refilling Electrodes with Electrolyte . . . . . 21

Tandberg Series 100 Tape Recorder . . . . . 22

VI. FIGURES . . . . . 23

## I. GENERAL DESCRIPTION OF UNIT

Each monitoring system (Fig. 1) consists of the following components:

- one (1) sleep-monitoring cap containing prefilled sponge electrodes in the Skylab M133 configuration or in the EMG configuration;
- one (1) preamplifier containing necessary elements to record EEG, EOG, EMG, and head motion; and
- one (1) control-panel assembly including
  - a. power amplifiers
  - b. 60-Hz notch filters
  - c. automatic electrode-test circuitry, and
  - d. modified Tandberg Series 100 magnetic tape recorder (4-channel) for preserving EEG, EOG, EMG, and head-motion signals; capable of at least 12 h continuous operation without tape change; tape input-output to drive external recording device.

### Recording Cap

The cap (shown in Fig. 2) is constructed from an elastic (lycra-like) material, fitting snugly on the scalp to provide enough tension to maintain scalp-electrode contact. The cap comes in three sizes, small, medium, and large, which accommodate most head sizes. Fig. 3 gives the respective cap dimensions.

Proper electrode positioning is assured by the fit of the cap around the ears and across the forehead. The padded chin strap, secured with velcro fasteners, maintains the assembly on the head.

Prefilled, electrolyte-saturated sponge electrodes are attached to the inside of the cap, and the electrode wires are led to a miniature electrical connector at the vertex which allows quick attachment of the preamplifier and accelerometer assembly. Each cap is stored in a sealed polyethylene bag while awaiting use.

The electrodes are made of a chlorided silver disc soldered to an insulated wire imbedded in a silicone-rubber base. A conical silicone-rubber sponge is attached to the base with silicone-rubber adhesive, then the entire assembly is coated with red liquid vinyl,

dried, and coated with clear liquid vinyl. The vinyl covering the tip of the sponge is removed, allowing injection of electrolyte, then the tip is resealed with vinyl.

A cross section of a completed, filled electrode may be seen in Fig. 4. The proper place to cut the electrode to release the electrolyte is the junction of the tab and the conical portion of the sponge. A uniform electrode opening is thus achieved with little effort and skill required of the subject.

#### Electrode Placement

1. Standard Configuration. Seven electrodes are utilized: four for EEG ( $C_1-O_1$ ,  $C_2-O_2$ , according to the ten-twenty system of the International Federation, Electroenceph. clin. Neurophysiol., 1958, 10: 371-375), two for EOG (left lateral canthus and central forehead), and one frontally located ground (see Fig. 5). This arrangement provides for two central-to-occipital EEG channels and one EOG channel that registers both right-left and up-down eye movements. An example of a recording made from a subject wearing such a cap is shown in Fig. 6.

2. EMG Configuration. In this configuration, two electrodes provide one EEG channel ( $C_2O_2$ ), two provide one EOG channel as above, two located in the chin strap provide one EMG channel, and one acts as a ground. As illustrated in Fig. 7, one EEG channel has been eliminated so that no change in the preamplifier or following stages is necessary. An example of a recording made using such a cap is provided in Fig. 8.

#### Preamplifier, Accelerometer, and Control Panel

The preamplifier-accelerometer unit provides initial amplification of the EEG and EOG signals in addition to supplying information regarding motion of the subject's head; this assembly is fastened to the recording cap near the vertex of the head, where minimal interference with the subject's comfort is assured. The amplified signals pass through a 7' cable connected to the control-panel assembly, which provides final amplification of the signals in addition to the necessary subject operational controls and the electrode-test circuitry. These two assemblies (shown in Fig. 1) receive their power from the Tandberg's power supply.

## Circuitry

The preamplifier-accelerometer and the control panel units are greatly interrelated electronically, therefore the circuit is described here as a single unit. The physical separation of the components is, however, indicated in accompanying diagrams.

Amplification Circuitry. As shown in the schematic (Fig. 10), initial amplification of EEG and EOG signals is accomplished in the preamplifier. Two TIS69s, a matched pair of N-channel field-effect transistors, are arranged in a differential input configuration and accept the unamplified signal from the electrodes. A 2N3707 transistor supplies a constant current to the common-source junction of the two TIS69s to provide improved rejection of common-mode signals which may appear at the inputs. The  $100\text{ k } \Omega$  potentiometer in the base circuit of the 2N3707 is adjusted so that the drain voltage of the TIS69s is approximately +5 V (referred to ground) when both inputs are shorted to ground. Two diodes (GE IN914A) are provided in the common-source circuit of the TIS69s and act in conjunction with the two IN914As in the common drain to prevent flow of current between electrodes during the electrode-testing mode of operation (see below). The initial stage of amplification provides a gain of approximately 10 and supplies a signal of low output impedance ( $\sim 1500\ \Omega$ ) to the following stage.

The preamplified EOG, EMG, and EEG signals are led to the amplification circuitry located in the control panel through individually shielded flexible cables. A Fairchild type 741 operational amplifier accomplishes first amplification, and associated filter circuits limit the bandwidth to the specified range. The signals then travel through the 60-Hz line notch filters and the final amplifier with gain control for input to the Tandberg recorder.

Accelerometer Circuitry. As indicated in Fig. 10, a dual-axis accelerometer and associated amplification circuitry are included within the preamplification unit, and these provide information concerning motion of the subject's head. Signals from the accelerometer are amplified by the field-effect transistor (TIS69) and led to the control panel assembly through flexible shielded cable. The accelerometer circuitry is shown in isolated form in Fig. 9A.

The accelerometer and the associated FET are located within a small cylinder (see Fig. 9B, construction view). The accelerometer itself is an Astatic 11T7B stereo crystal cartridge which has been

modified by the addition of a 0.08 gm mass at the tip of the recording stylus.

As indicated in Fig. 9C, the accelerometer is oriented within the preamplifier assembly so that its axes of maximal sensitivity are aligned in the vertical (i. e., up-down) and lateral (i. e., side-to-side) directions when the preamplifier is correctly mounted on the recording cap.

Electrode-Test Circuitry. This section performs automatic testing of each recording electrode before the sleep period begins. The control panel, easily visible to the subject during application of the cap, contains a series of indicator lamps, each representing one of the sponge-electrode sensors on the cap. When the cap is donned by the subject, he moves the panel-selector switch from the "off" position to the "test" position, thereby activating the automatic test circuitry. A small test current (0-10  $\mu$ A) is passed through the ground electrode to each recording electrode, and this current is sensed to provide an indication of interelectrode resistance. If a given electrode is in proper contact with the scalp, its average resistance will be 50,000  $\Omega$  or less, and this condition is indicated by illumination of the corresponding lamp in the simulated control-panel display. Improper contact can usually be resolved by slightly rocking the sensor to reposition the sponge through the hair and against the scalp.

Circuit Details. Operation of the electrode-test circuitry is illustrated in Fig. 10. By applying power to the electrode-test circuitry, the input N-channel (FET) in the preamp is connected to the test circuit by the mode switch as shown. All FET drains connect to a common ground through 1 M  $\Omega$  potentiometers. Each FET gate connects, as usual, to an individual electrode on the recording cap, and the electrodes in turn make contact with the subject's scalp. A single cap electrode serves to ground the subject to the system common ground.

In the normal recording mode the FETs are used as amplifiers, and the drain and source points are always biased positive with respect to ground, thus keeping the gate-source/drain junction reverse-biased, resulting in no significant current flow (high input impedance). In the electrode-testing mode, the astable multivibrator output is connected to the cap ground electrode. When the cap ground electrode goes positive, the FET gate-drain junction is biased in a forward direction,



permitting current flow from gate to drain. If the cap ground electrode and the recording electrode are both in contact with the subject's scalp when cap ground goes positive, current will flow from the cap ground, through the two involved electrodes, across the forward-biased gate-drain junction, and through the  $1\text{ M } \Omega$  potentiometer in the sensing circuit to signal ground. The amount of current passing through the  $1\text{ M } \Omega$  resistor, and thus the voltage developed across it, will depend upon the interelectrode impedance ( $R_e$ ) at the scalp. As  $R_e$  becomes lower (i. e., the better the electrode contact), the voltage developed across the sensing resistor increases.

The FET in the sensing circuit, the 2N3820 (FET), detects and amplifies the voltage developed across the  $1\text{ M } \Omega$  resistance. The amplified voltage serves to turn the following stage, the 2N3702 transistor, fully on when  $R_e$  drops below 100,000 (each electrode averages 50,000  $\Omega$ , indicating adequate scalp-electrode contact). The 2N3702 drives the final stage, 2N2270, which, in turn, operates the panel-indicator lamp for the appropriate recording electrode. A separate sensing circuit exists for each of the 6 recording electrodes, and the indicator lamps are arranged in a display simulating the cap-electrode configuration, permitting the subject to rapidly identify the faulty electrode. If the common-ground electrode on the cap is at fault, no sensing circuit will operate, and all indicator lamps will be extinguished.

## II. SPECIFICATIONS

### Preamplifier

Input impedance: greater than  $1000 \times 10^6 \Omega$   
 Common-mode signal rejection:  $\sim 60$  dB  
 Frequency response: 0.11 Hz - 40 Hz (-6 dB)  
 Noise level (referred to input):  $3 \mu\text{ V}$  peak-to-peak

### Tandberg Series 100 Tape Recorder

See the Tandberg Operating and Service Manual, Vol. 1, and note the modifications listed below.

### Modifications of Tandberg

1. Past experience in this laboratory indicates that the highest amplitude EEG signals (of interest in the study of sleep) are no greater than 300  $\mu\text{V}$  p-p. Consequently, the gain factors have been set as follows:

EEG and EOG channels. . . . + 200  $\mu\text{V}$  equivalent to maximum tape input signal (± 60% deviation)

2. An external Record lever (Record linkage) has been added to start or stop recording while the front of the recorder is covered by the control-panel assembly. (See Figs. 11 and 12a )

3. A lock pin and holders depress the Erase and Record buttons, holding the unit in the record mode (Fig. 12 a ).

4. Output connectors and channels (Fig. 13) on the left side of the modified recorder assembly.

output impedance: approx. 20  $\Omega$ , single ended, from the recorder in the reproduce mode

jack numbers: Ch. 1, EOG; Ch. 2, EEG or EMG;  
Ch. 3, EEG; Ch. 4, accelerometer

output gain adjustment: none

output voltage: ± 7.5 peak for ± 60% deviation

5. The slowest tape speed has been reduced from 1-7/8 ips to 15/16 ips.

### Magnetic Tape

Brand used: Scotch #290

Size: 1/4 inch X 3600 ft, 0.5 mil

Recording time: 12 h at 15/16 ips

## Tape Handling

The tape should be handled carefully so as to avoid wrinkles that may prevent a smooth tape motion. Protect the tape from being contaminated by dust, adhesives or lubricants. All such impurities will disturb tape motion, and dust may even contain particles that cause excessive wear of the head fronts.

Reels with recorded tape should be kept away from magnetic fields, and must not be exposed to high temperatures.

## III. CONDUCTING A RECORDING SESSION

### Preliminary Preparation

This may be done in the laboratory well before the recording session is to be held to minimize the time required to prepare equipment at the recording site.

1. Insert tape (see section 4.2, Vol. 3, Tandberg manual), and place tape in motion by lifting the Record lever (Fig. 11). This checks tape movement only. Depress Record lever, and close the cover over the tape reels.
2. Open the front cover and depress the Erase and Record buttons (Fig. 12a), inserting the lock pin.
3. Plug in the preamplifier cable to the EEG plug receptacle on the front of the control panel. (See Fig. 14 and Fig. 1.)
4. Attach the shorting connector to the preamplifier plug.

### EMG or EEG Mode

To use the EMG mode, both switches on the inside of the front cover (Fig. 12b) should be turned up. This blocks channel 2 EEG ( $C_1 O_1$ ) and picks up EMG.

To use the normal EEG mode, the switches should be turned down.

5. Set the Selector switch on the control panel to the check position. All the lamps, which represent the location of the electrodes actually used in the recording cap, should flash.

6. Turn the Selector switch to the run position. Allow the pre-amplifiers and power amplifiers to equilibrate; this can be checked by observing each channel in the monitor scope. The input/output switch on the Tandberg should be set on Prerecord. Use the input offset controls as required to center the light beams on the monitor scope at zero (no deflection).

7. Turn the Selector switch to off, disconnect the shorting plug and the preamplifier from the EEG plug on the control panel.

#### Final Preparation

1. Set the recorder and control-panel assembly on a table or the floor next to the subject, with the front of the control facing him. Plug the instrument into a 110 V ac outlet.

2. Either prepare for bed (if a sleep recording is to be done), or settle comfortably in the environment where the recording takes place.

3. Remove the sleep cap from the plastic bag, and attach the preamplifier to the vertex of the cap as in Fig. 1.

4. Attach the preamplifier cable to the control-panel assembly (as in Fig. 1).

5. Carefully prepare the sponge electrodes by clipping the sealing tab off each electrode (Fig. 15). It may be necessary to cut off a little more than just the tab at the junction of the conical part of the sponge to obtain satisfactory scalp/electrode contact.

6. Put the cap on and secure the chin strap (it should be comfortably snug).

#### Use of EMG Cap

The EMG cap differs from the standard (M133 configuration) cap in that it has two additional electrodes in the chin strap, EMG 1 and

EMG 2. These electrodes should be filled with electrolyte in the same manner as the other electrodes. When fastening the chin strap, be sure that these electrodes are centered as much as possible. There is ample velcro at either end of the chin strap for length adjustment.

Great care should be used in adjusting the length on the left side where the wires leading to the EMG electrodes are attached.

TO LENGTHEN: gently pull out the slack created by looping the EMG wires loosely on the left side of the cap.

TO SHORTEN: gently increase the slack in the EMG wires on the left side of the cap.

NEVER JERK THE WIRES while adjusting the chin-strap length.

The chin strap should be comfortably snug with all electrodes in good contact with the skin. Check these electrodes on the control panel along with the others during the electrode-check procedure.

7. If it is a sleep recording, get into bed; if it is not a sleep recording, assume a comfortable position.

8. Start the recorder by lifting the Record lever (Fig. 11).

9. Turn the Selector switch on the control panel to the check position (Fig. 14). Rock each electrode slightly to position the exposed sponge tip against the scalp through the hair. Correct contact is verified by illumination of the red lamps on the control panel (Fig. 14) which correspond to the arrangement of electrodes on the cap.

10. Turn the Selector switch to run. Do not turn the recorder off until the recording period is terminated. If it is necessary to get up during recording, simply disconnect the preamplifier cable from the control panel and let the recorder continue running. Upon returning, again connect the cable to the recorder and repeat step 9. Then switch to run and continue as before. NEVER unplug the recorder from the wall socket during a recording period.

11. At the end of the recording period, turn the Selector switch to the check position to determine if all the electrodes are still in proper contact.

12. Turn the Selector switch to the off position, and disconnect the preamplifier cable from the recorder. Stop the recorder by depressing the Record lever.

13. Remove the cap and disconnect the preamplifier, then unplug the recorder from the electrical outlet.

In numerous laboratory trials, it has been determined that the entire preparation procedure as outlined above can easily be accomplished by the subject himself in 3-5 min. Post-recording "breakdown" time is only about 1 min, since it is only necessary for the subject to remove the cap.

#### IV. INSTRUCTIONS FOR PLAYING BACK DATA

To connect the recorder to an external reproducer, such as an EEG machine, use the external plugs supplied with the Neurophysiological Monitoring System. Attach these to the output connectors before following the instructions given below.

1. Place the Selector switch on the control panel in the off position. The control panel is not needed for data playback.
2. Rewind the tape (see Tandberg manual, Vol. 3, section 4.3).
3. Before applying power to the recorder unit, remove the lock pin from the Erase/Record buttons.
4. Place the output Prerecord/Reproduce switches in the Reproduce position for all channels.
5. Lift the Record lever, making sure that the Erase and Record buttons are not illuminated.
6. After playback, depress the Record lever.
7. Turn the Power switch on the Tandberg recorder off.

## V. MAINTENANCE

### Storage and Care of Recording Caps

New caps with filled and sealed electrodes can be stored on the shelf at room temperature for up to 2 months as long as the bag remains sealed. After 2 months or after the caps have been used, they must be prepared as outlined below and placed under refrigeration. With proper care they can be reused many times.

1. Wash the cap in lukewarm water and pHisoHex, being sure to wash out all electrolyte that may be on the cap material.
2. Rinse well in water.
3. Wrap in a towel for a few minutes (do not wring or shake).
4. Place on a clean towel and air dry. (This should take 2-3 hours.)
5. When the cap is dry, insert a small amount of electrolyte in each electrode (see procedure below), checking each electrode as it is filled for cracks in the vinyl coating and/or breaks in the wires or insulation.
6. Place a damp square of gauze over the cut end of each electrode, seal the cap in a vinyl bag, and refrigerate. If the cap is not used within 2 weeks, remove it, check it, refill it with electrolyte, and refrigerate again.

### Refilling Electrodes with Electrolyte

Use a syringe with a 20-gauge hypodermic needle. Fill the syringe (without the needle attached) with electrolyte solution (KM-137), plunging the syringe deep into the solution so that no air bubbles are sucked in with the solution. If the syringe contains air bubbles, empty it and refill it. Wipe the outside of the syringe and fasten the needle in place.

Check each electrode for cracks before filling. Insert the needle straight down, well into the sponge portion of the electrode. Slowly

inject electrolyte until the sponge is full but not overflowing onto the cap. Place a small square of moist gauze over each electrode opening.

#### Tandberg Series 100 Tape Recorder

See Volume 6 of the Tandberg Operating and Service Manual for instructions.



VI. FIGURES

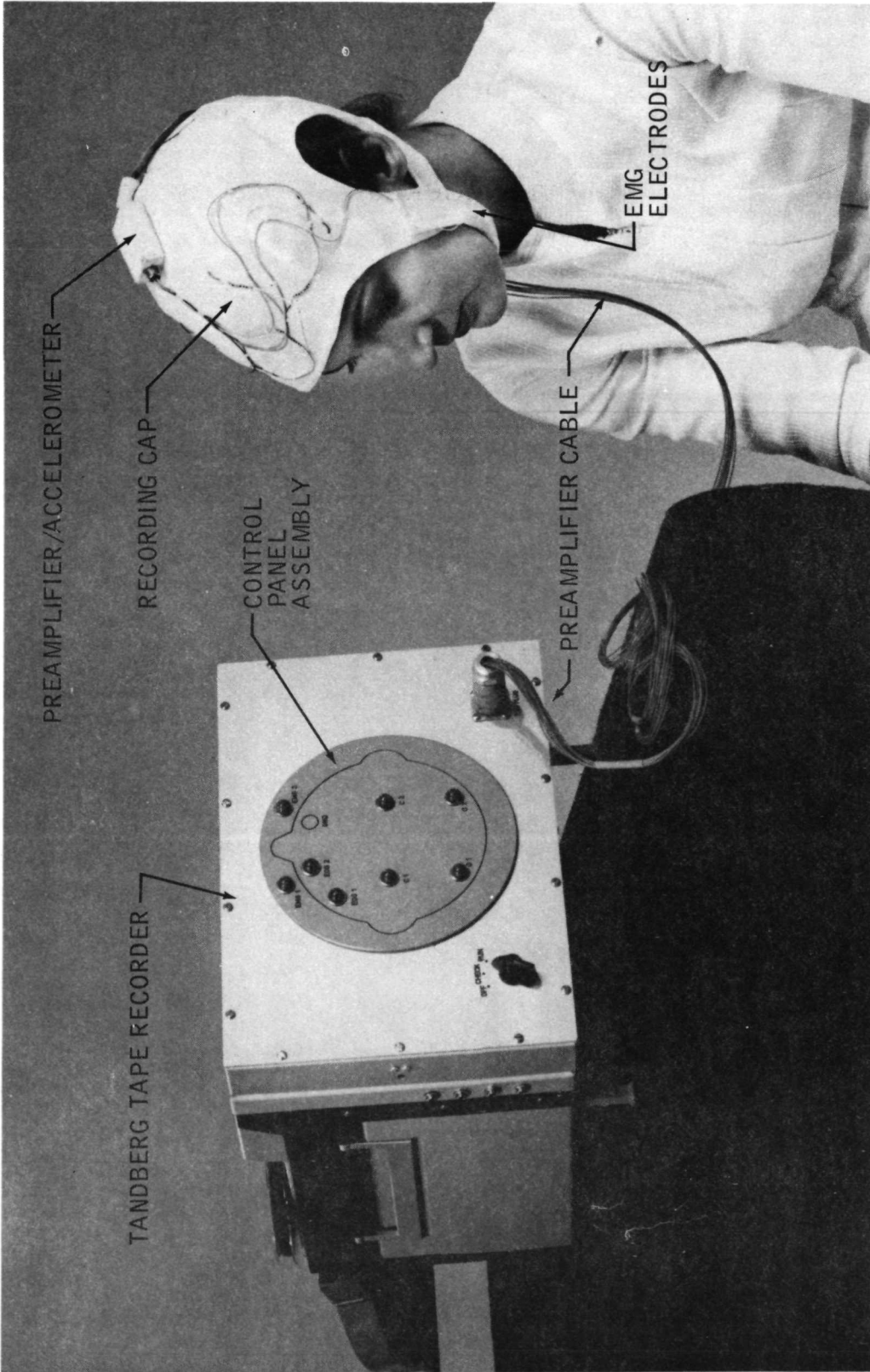

FIGURE 1. - THE NEUROPHYSIOLOGICAL MONITORING SYSTEM

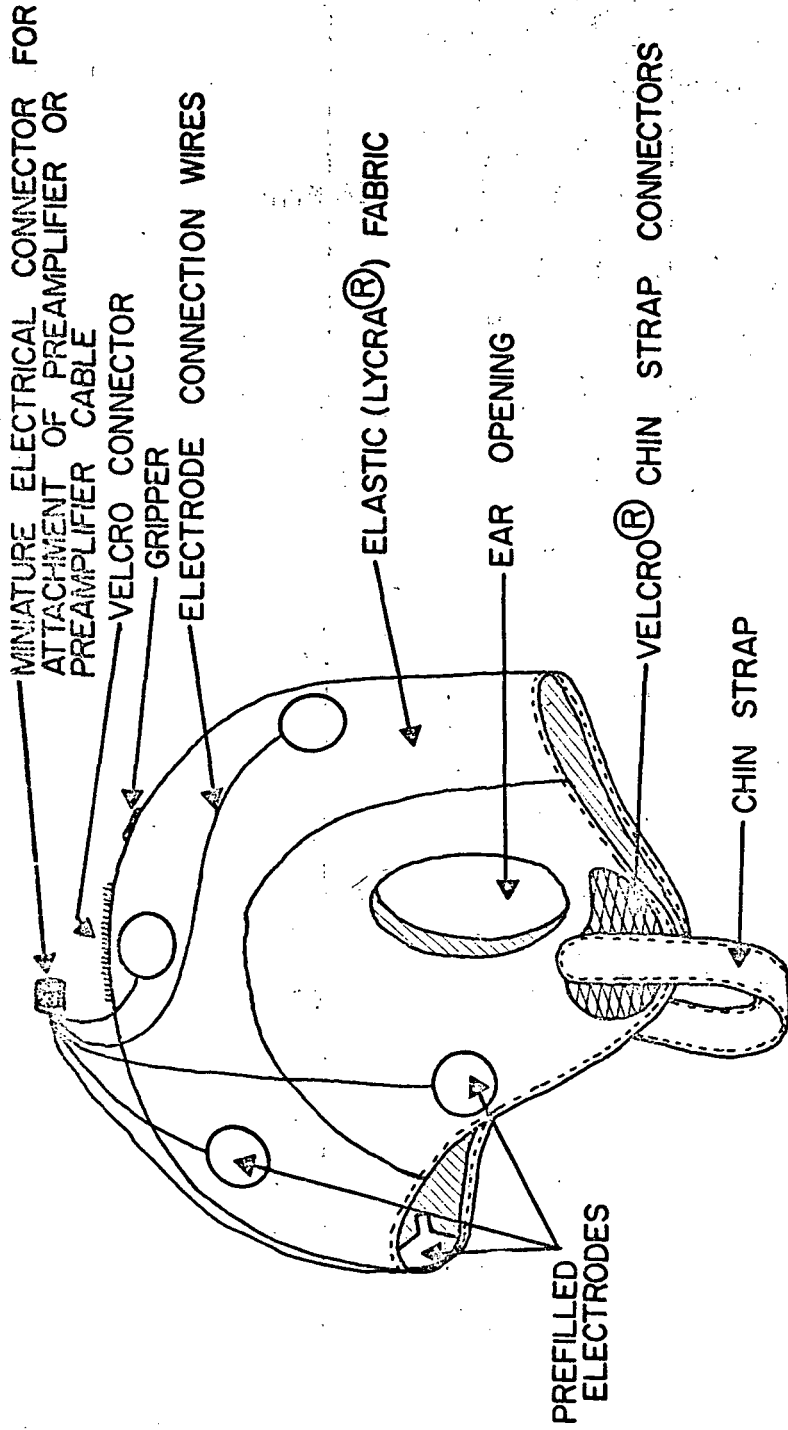
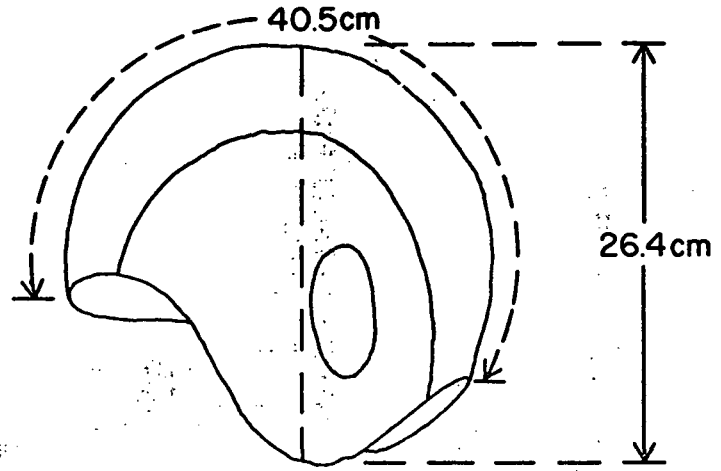
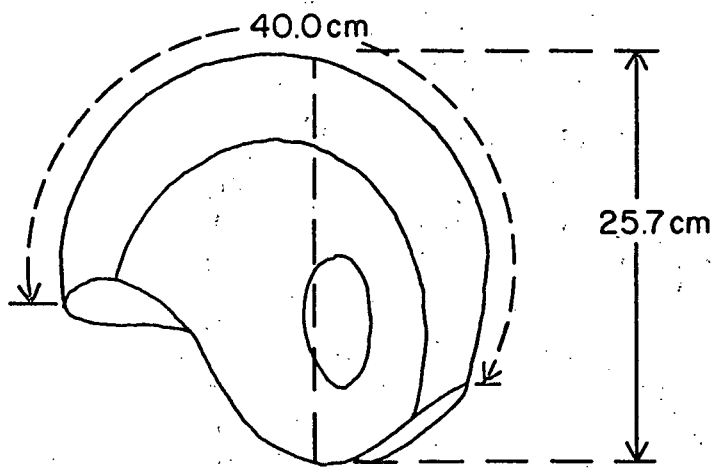

FIGURE 2. - EEG RECORDING CAP

LARGE



MEDIUM



SMALL

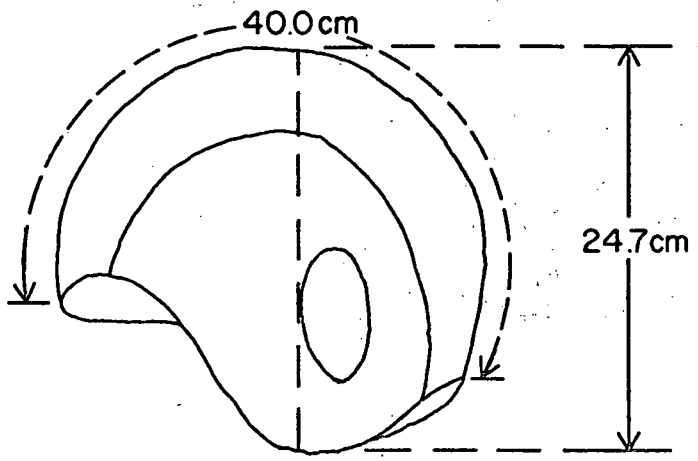

FIGURE 3. - COMPARISON OF CAP SIZES

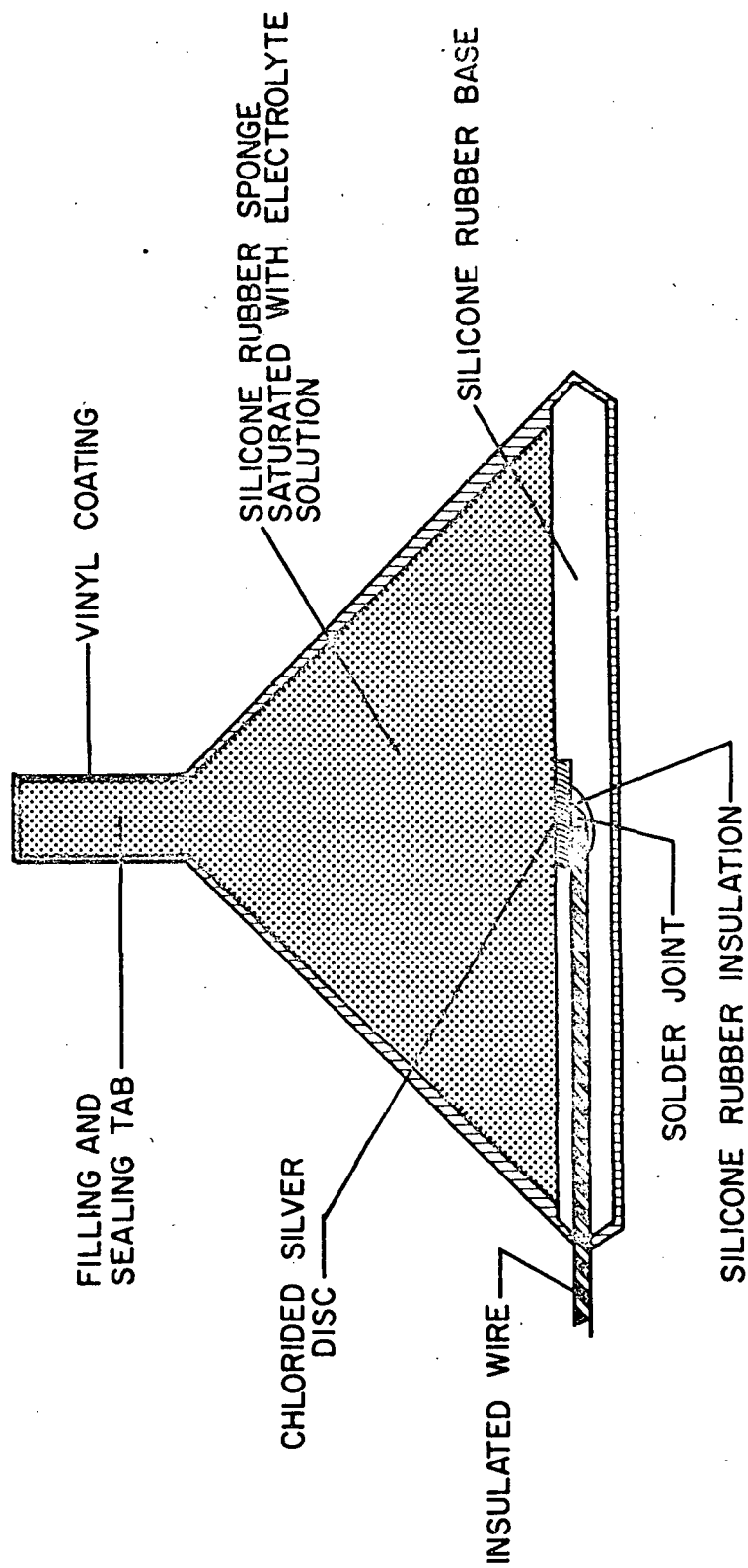

FIGURE 4. - CROSS SECTION OF PREFILLED SPONGE ELECTRODE

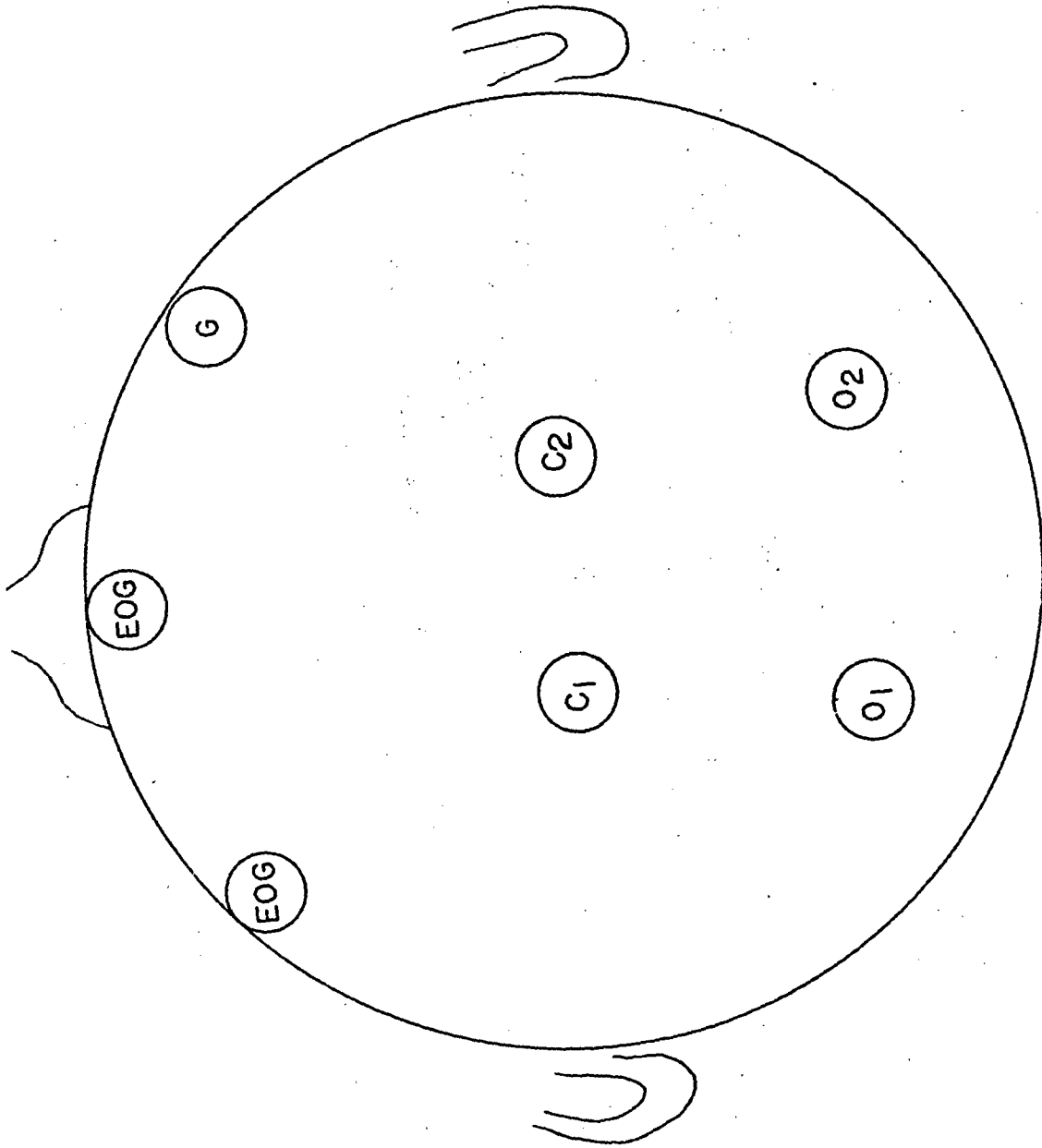

FIGURE 5. - STANDARD CAP ELECTRODE POSITIONS

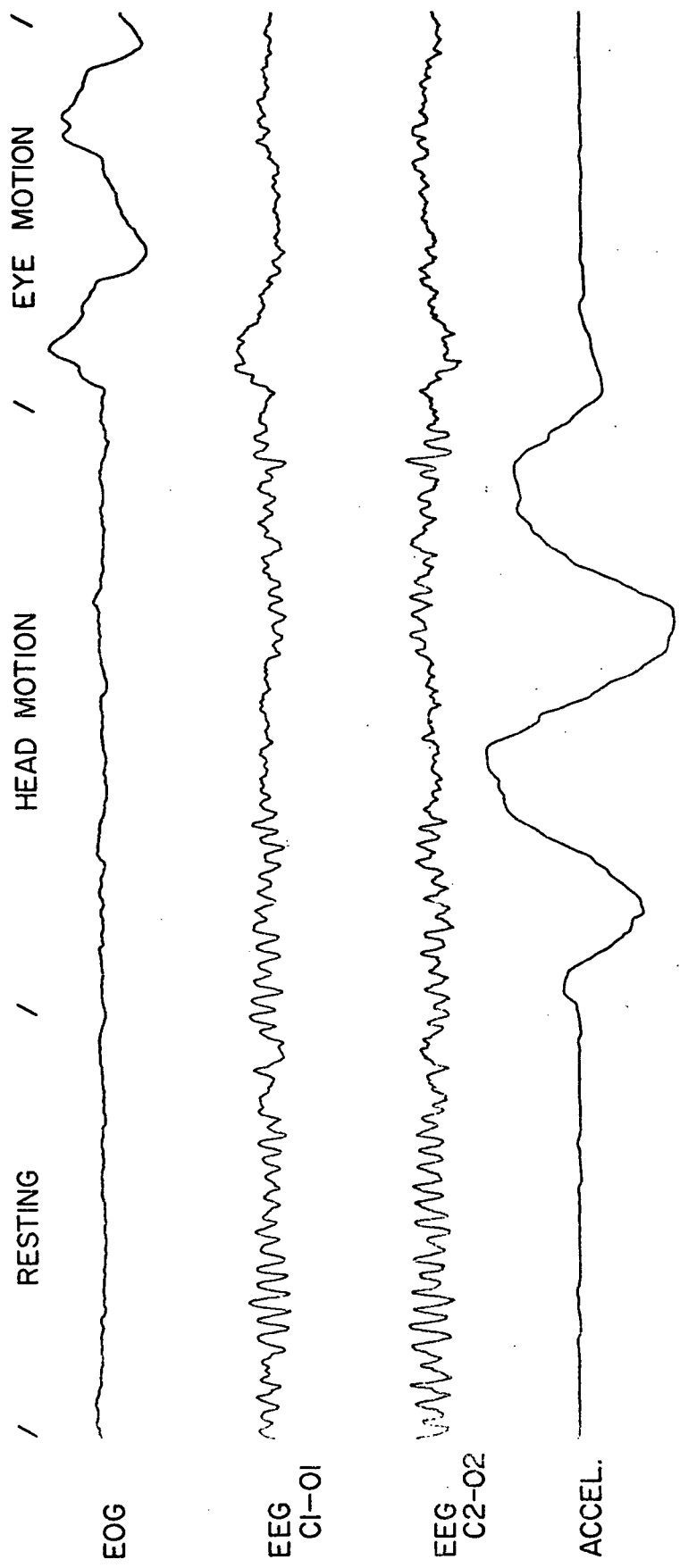

FIGURE 6. - EEG, EOG, ACCELEROMETER FROM STANDARD ELECTRODE CAPS

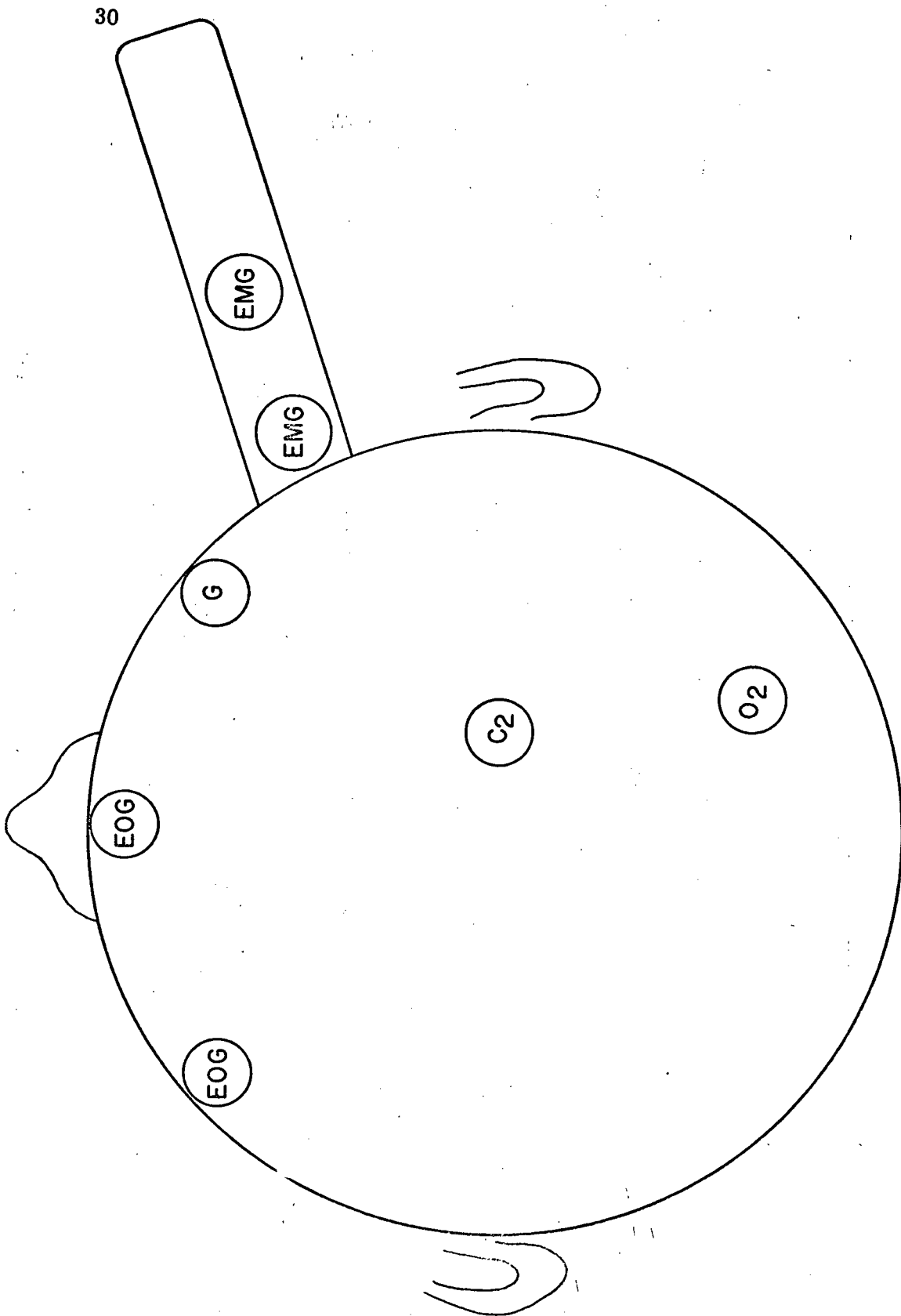

FIGURE 7. - EMG CAP ELECTRODE POSITIONS



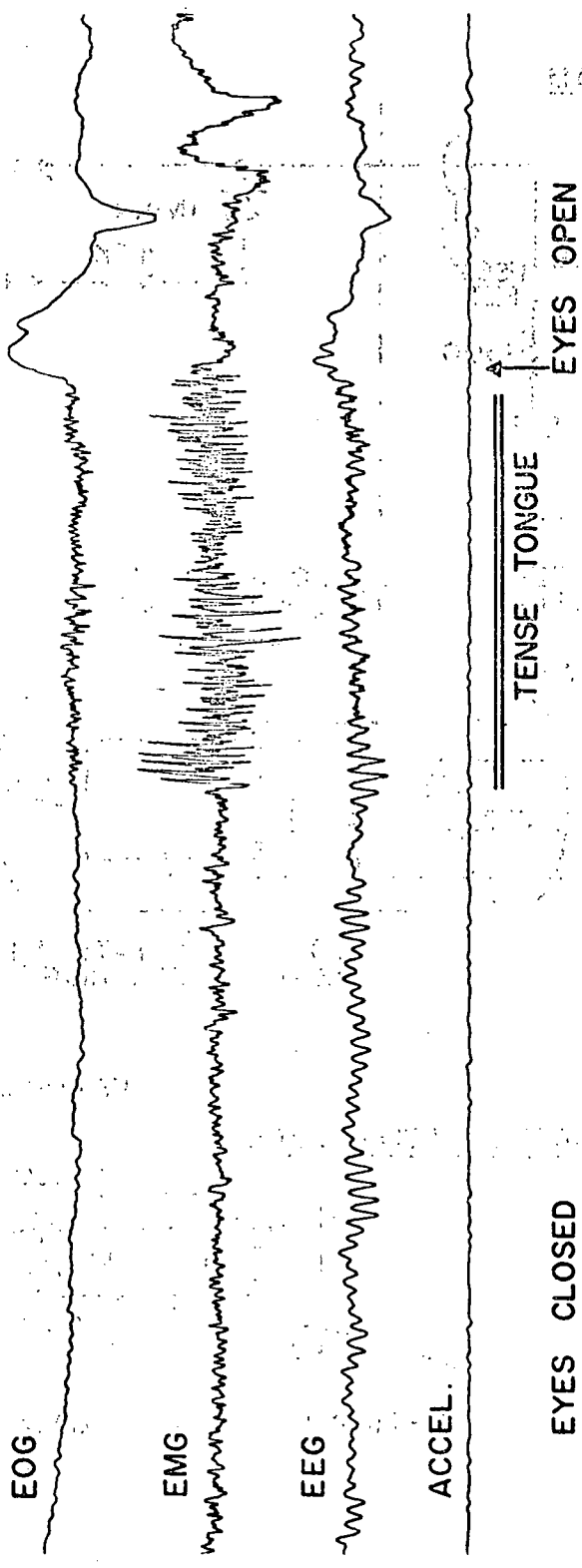
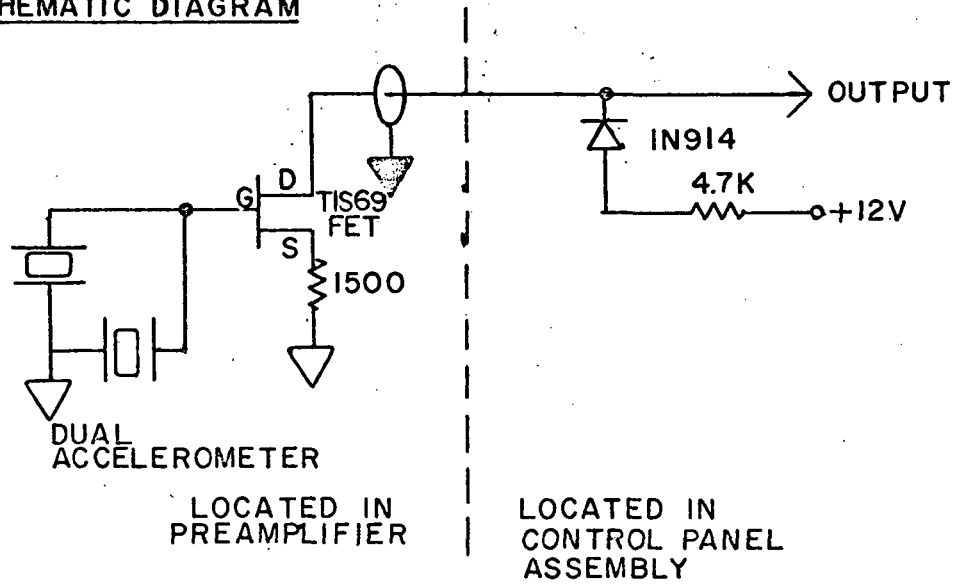
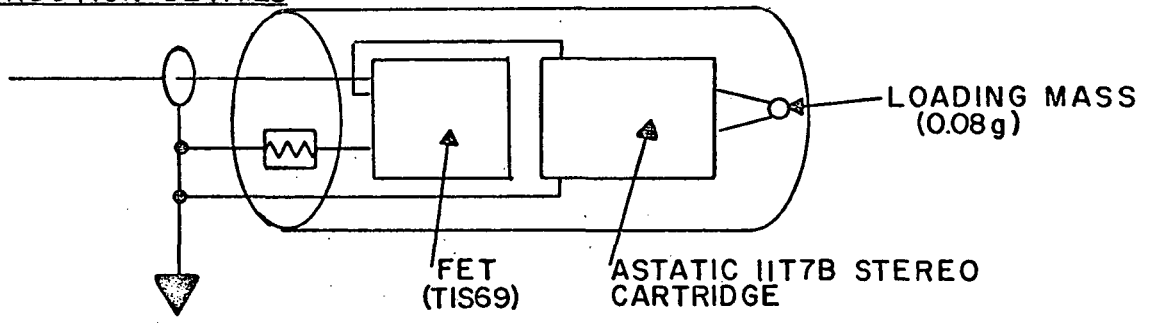

FIGURE 8. - EXAMPLE OF CH104-T RECORDING WITH EMG CAP CONFIGURATIONS.

A. SCHEMATIC DIAGRAM



B. CONSTRUCTION DETAILS



C. ORIENTATION OF ACCELEROMETER AXES

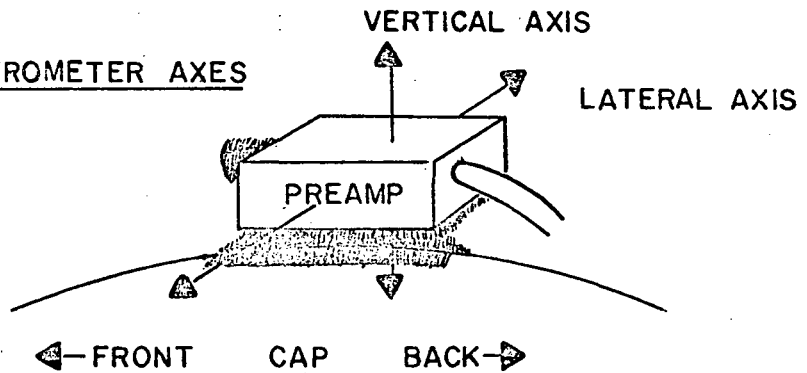

FIGURE 9. - DUAL ACCELEROMETER

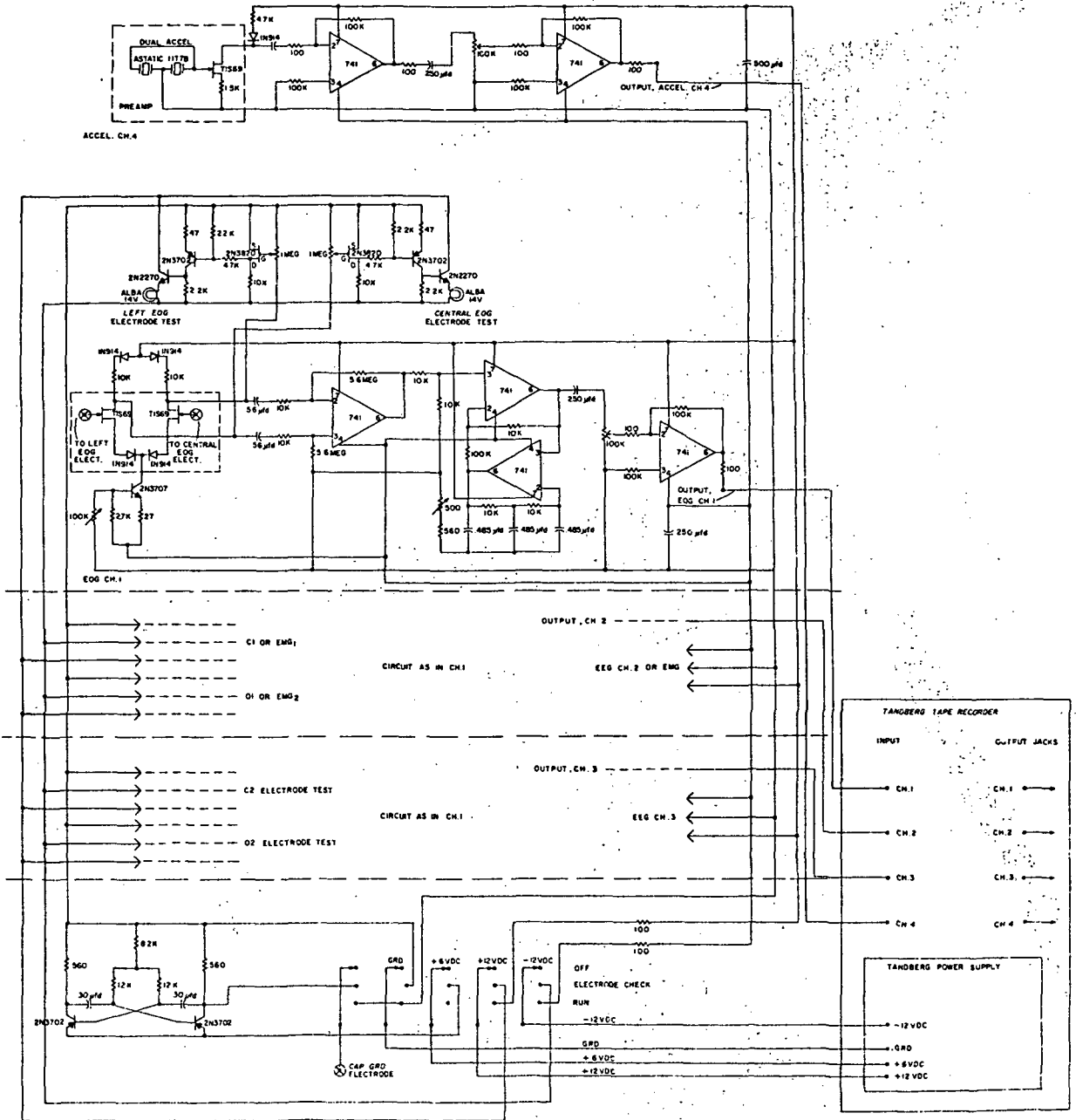

FIGURE 10. - AMPLIFICATION CIRCUITRY SCHEMATIC DIAGRAM.

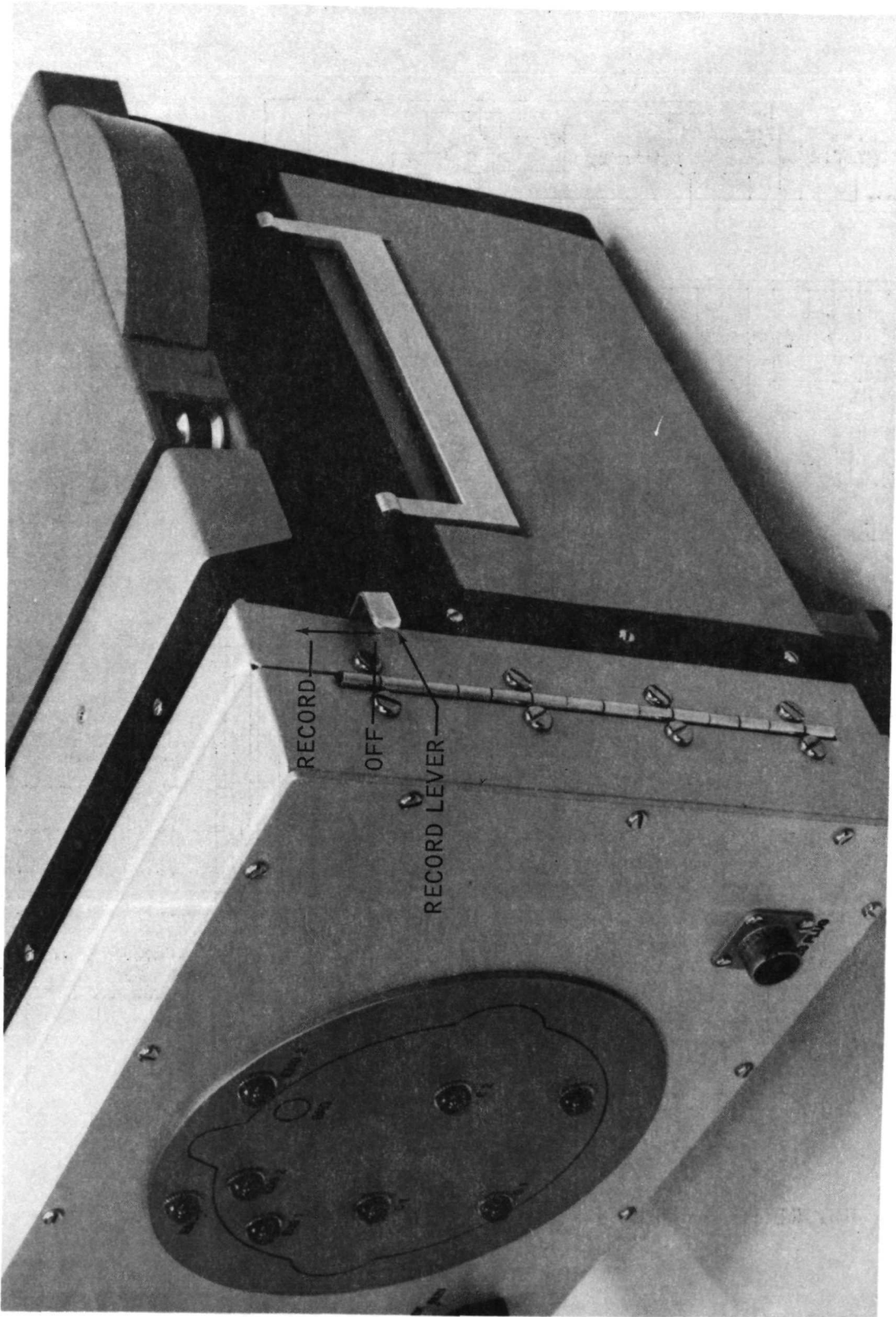

FIGURE 11. - SIDE VIEW OF CONTROL PANEL ASSEMBLY

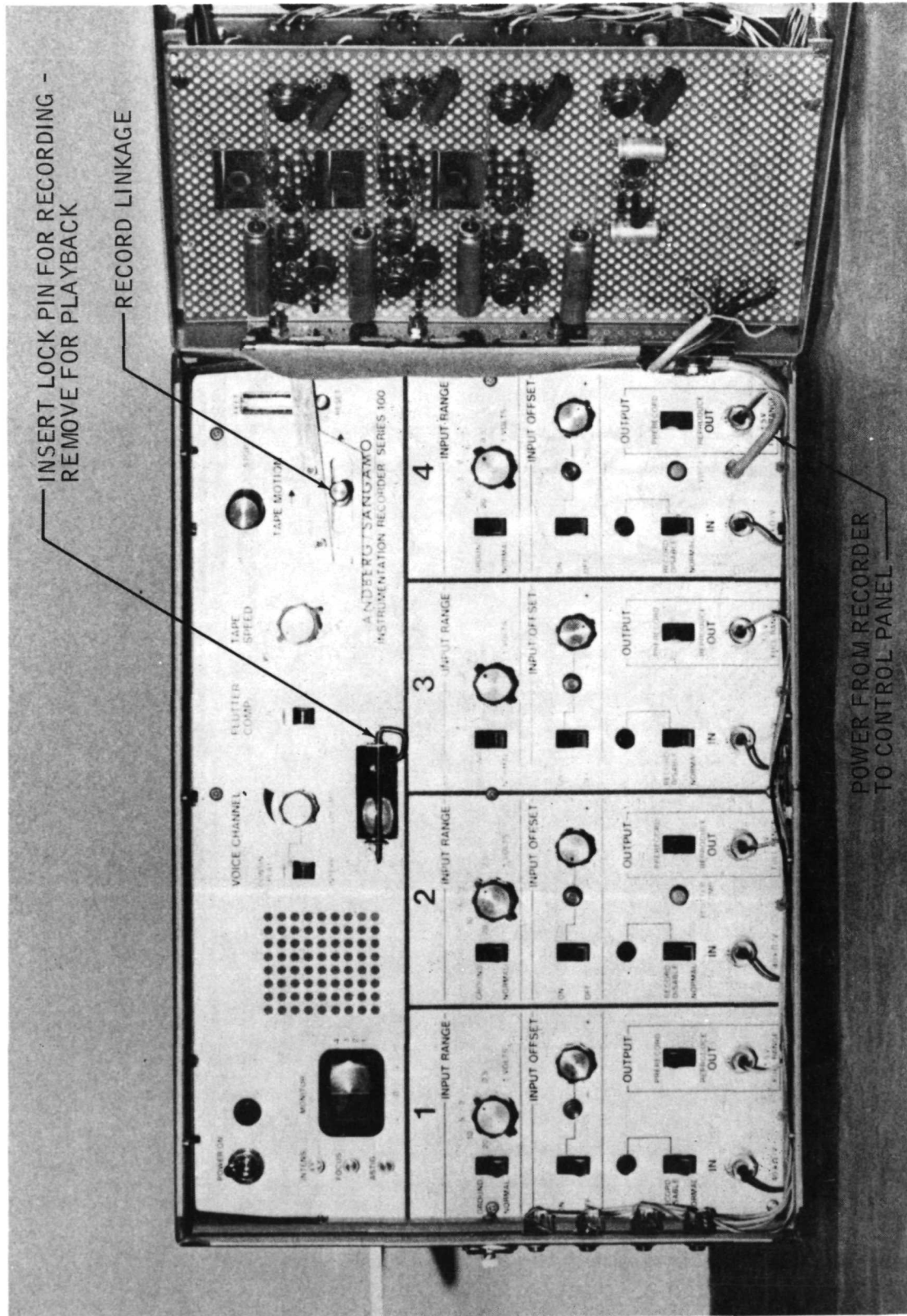

FIGURE 12a. - TANDBERG RECORDER WITH FRONT OPEN

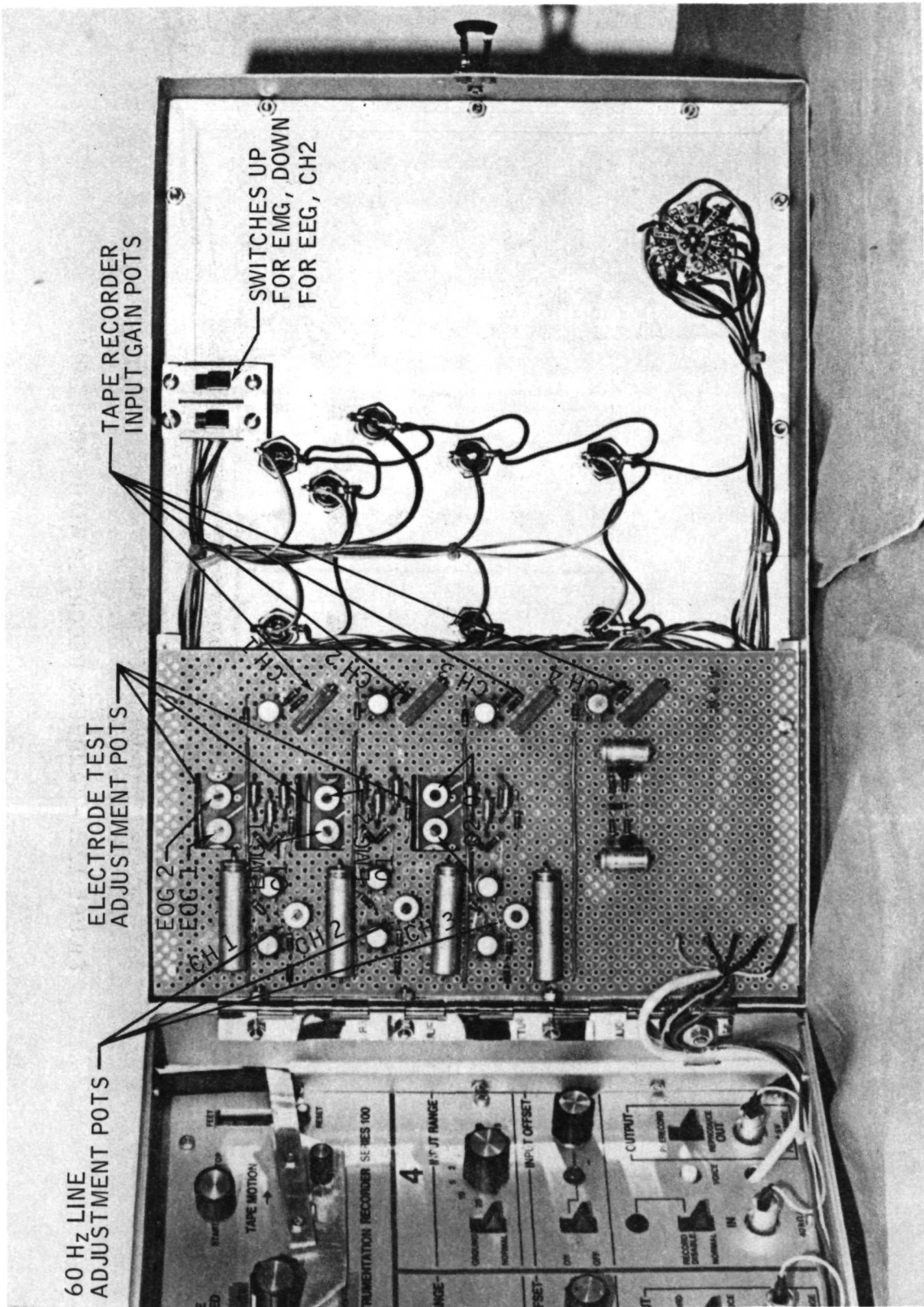

FIGURE 12b. - CONTROL PANEL OPEN

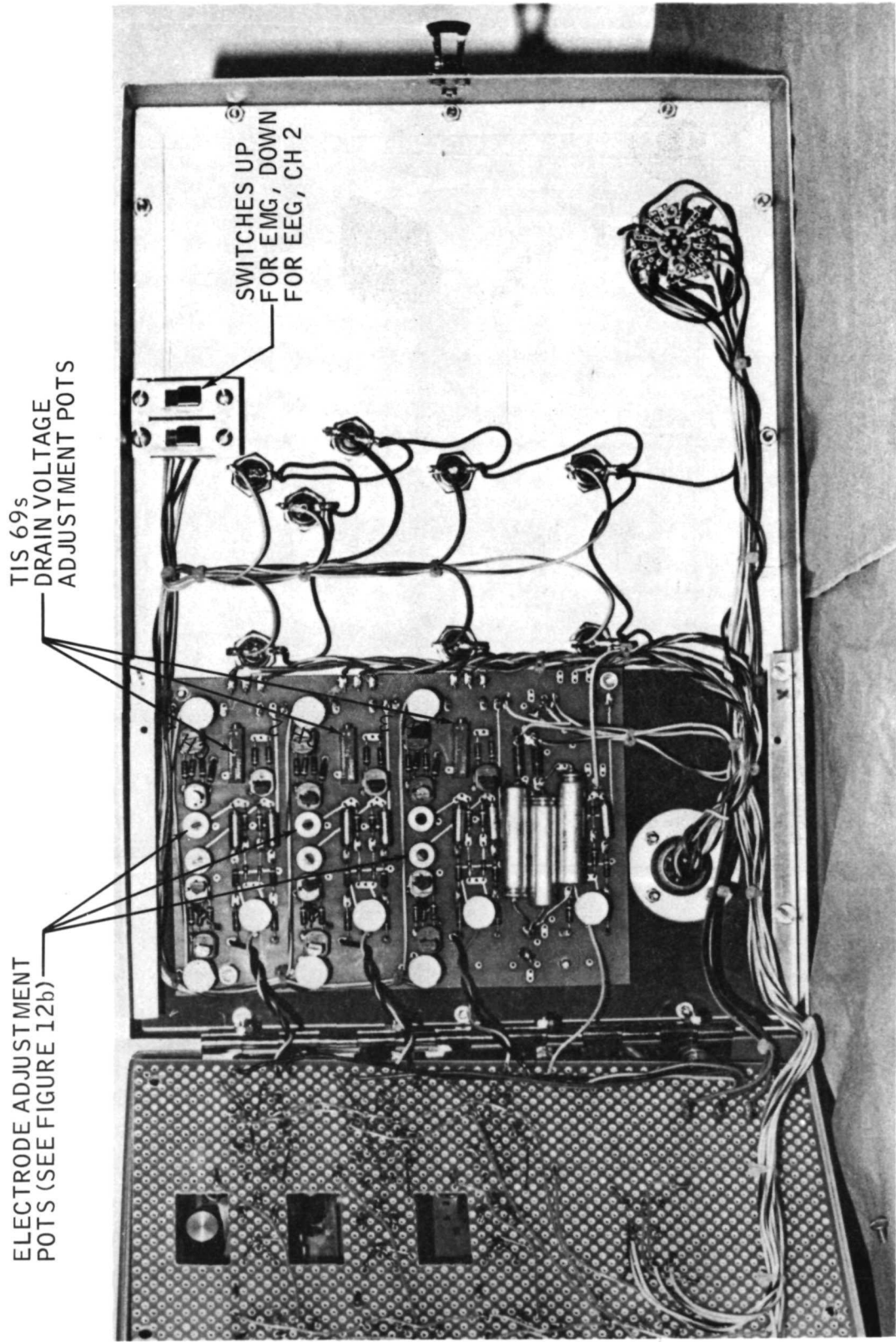

FIGURE 12c. - CONTROL PANEL OPEN

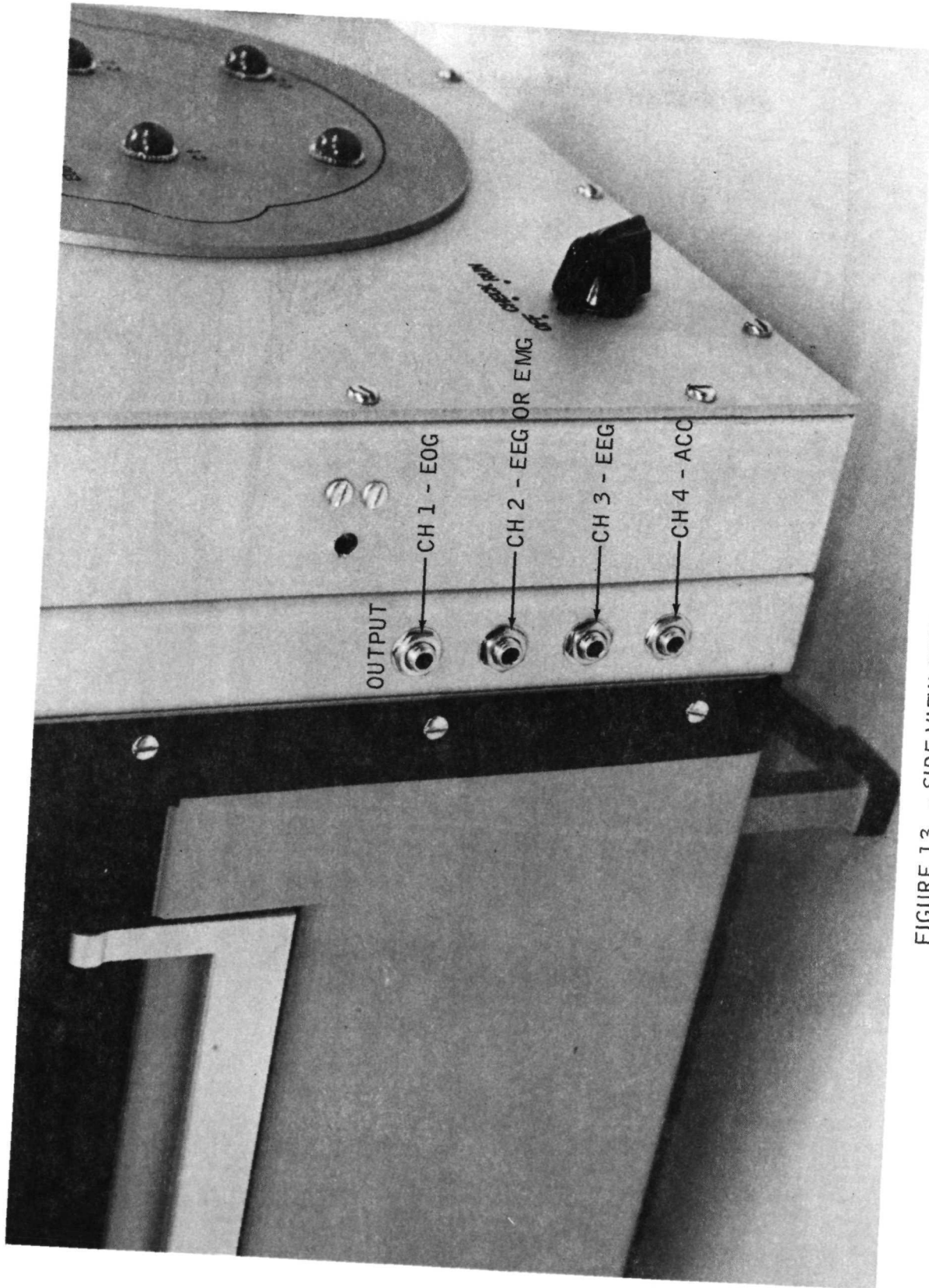

FIGURE 13. - SIDE VIEW SHOWING OUTPUT JACKS



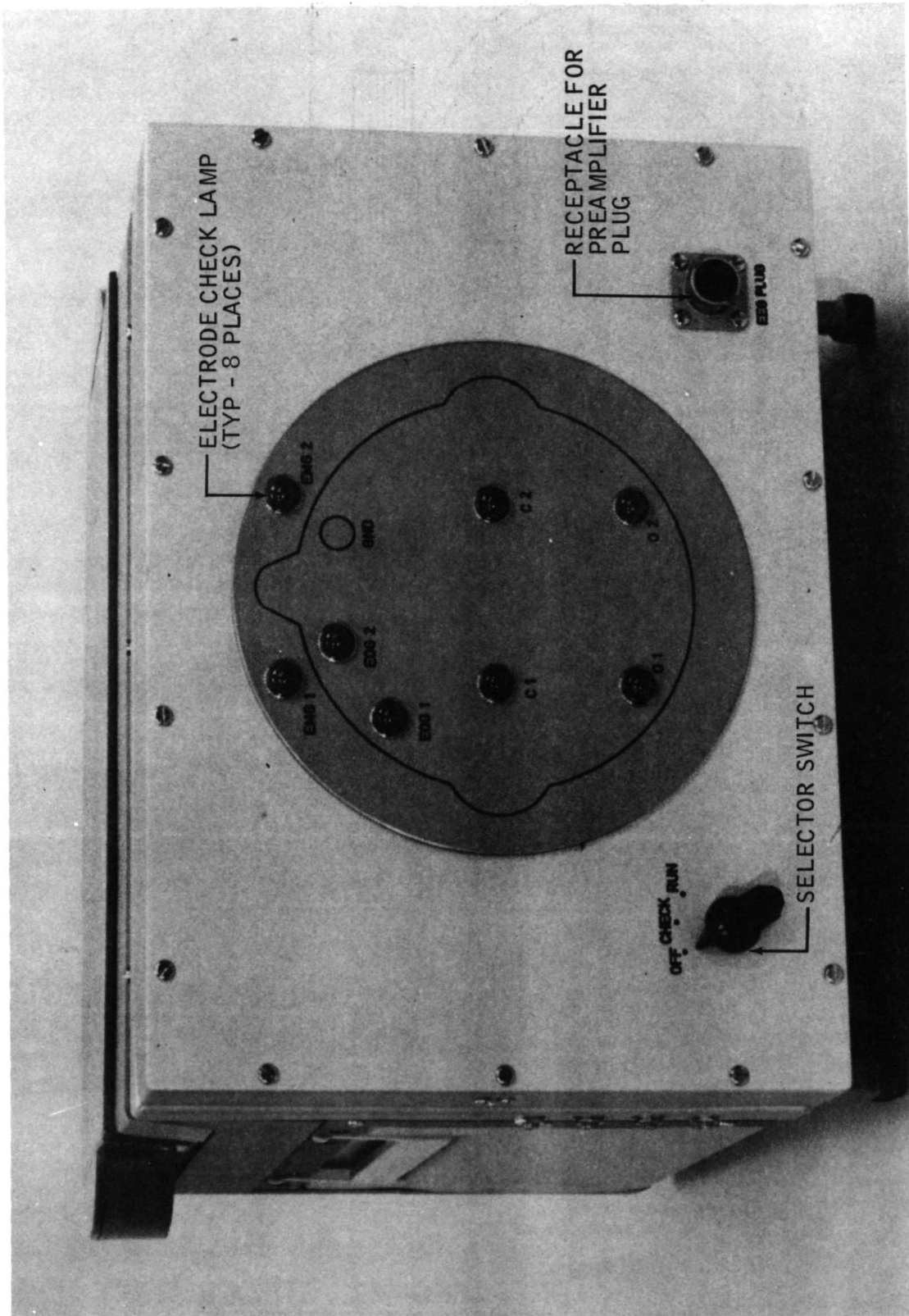
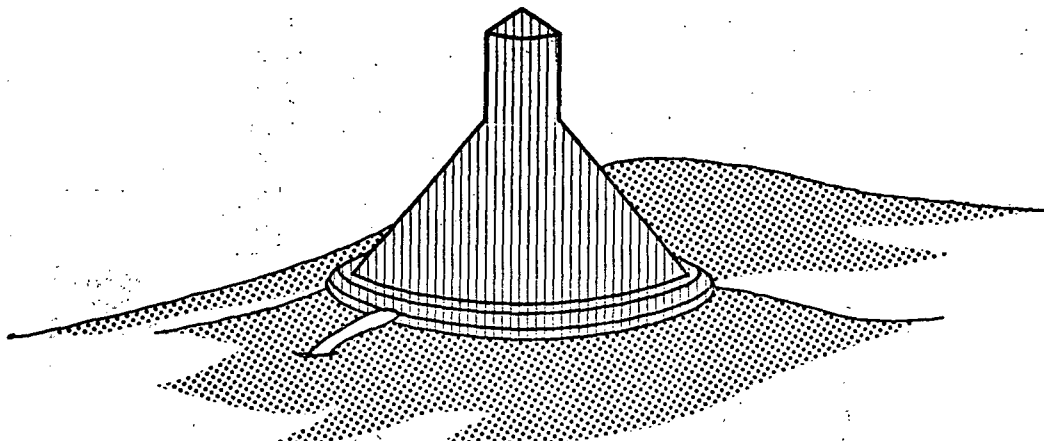
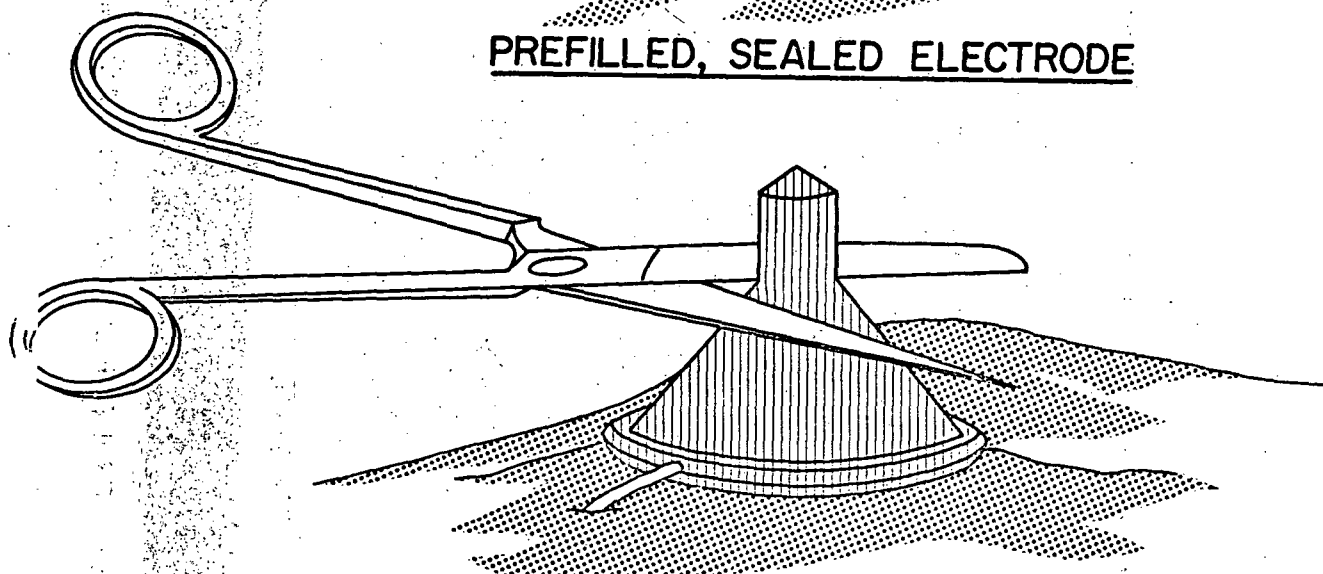

FIGURE 14. - FRONT OF CONTROL PANEL ASSEMBLY



PREFILLED, SEALED ELECTRODE



REMOVAL OF SEALING TAB

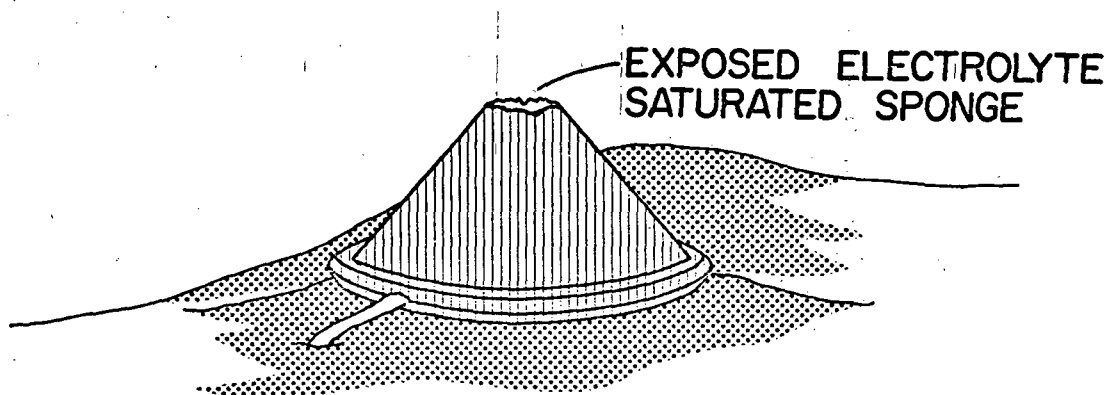

PREPARED ELECTRODE

FIGURE 15. - PREPARATION OF ELECTRODE FOR USE.

INSTRUCTION MANUAL FOR  
CH104 NEUROPHYSIOLOGICAL MONITORING ASSEMBLY

(Final)

Prepared in accordance with Contract NAS 9-13065

## CONTENTS

I. GENERAL DESCRIPTION OF UNIT . . . . .	43
Recording Cap . . . . .	43
Electrode Placement . . . . .	44
Preamplifier, Accelerometer, and Control Panel . . . . .	44
Circuitry . . . . .	44
II. SPECIFICATIONS . . . . .	47
Preamplifier . . . . .	47
III. CONDUCTING A RECORDING SESSION . . . . .	47
Preliminary Preparation . . . . .	47
EEG or EMG Mode. . . . .	47
Final Preparation . . . . .	48
Use of EMG Cap . . . . .	48
Use with External Recording/Reproducing Device . . . . .	50
IV. MAINTENANCE . . . . .	50
Storage and Care of Recording Caps . . . . .	50
Refilling Electrodes with Electrolyte . . . . .	51
V. FIGURES . . . . .	52

## I. GENERAL DESCRIPTION OF UNIT

Each CH104 neurophysiological monitoring assembly (Fig. 1) consists of the following components:

- one (1) sleep-monitoring cap containing prefilled sponge electrodes in the Skylab M133 configuration or in the EMG configuration;
- one (1) preamplifier containing necessary elements to record EEG, EOG, EMG, and head motion; and
- one (1) control-panel assembly including
  - a. power amplifiers
  - b. 60-Hz notch filters
  - c. automatic electrode-test circuitry
  - d. outputs to drive external recording devices.

### Recording Cap

The cap (shown in Fig. 2) is constructed from an elastic (lycra-like) material and fits snugly on the scalp to provide enough tension to maintain scalp-electrode contact. The cap comes in three sizes, small, medium, and large, which accommodate most head sizes. Fig. 3 gives the respective cap dimensions.

Proper electrode positioning is assured by the fit of the cap around the ears and across the forehead. The padded chin strap, secured with velcro fasteners, maintains the assembly on the head.

Prefilled, electrolyte-saturated sponge electrodes are attached to the inside of the cap, and the electrode wires are led to a miniature electrical connector at the vertex which allows quick attachment of the preamplifier and accelerometer assembly. Each cap is stored in a sealed polyethylene bag while awaiting use.

The electrodes are made of a chlorided silver disc soldered to an insulated wire imbedded in a silicone-rubber base. A conical silicone-rubber sponge is attached to the base with silicone-rubber adhesive, then the entire assembly is coated with red liquid vinyl, dried, and coated with clear liquid vinyl. The vinyl covering the tip of the sponge is removed, allowing injection of electrolyte, then the tip is resealed with vinyl.

A cross section of a completed, filled electrode may be seen in Fig. 4. The proper place to cut the electrode to release the electrolyte is the junction of the tab and the conical portion of the sponge. A uniform electrode opening is thus achieved with little effort and skill required of the subject.

### Electrode Placement

1. Standard Configuration. Seven electrodes are utilized: four for EEG ( $C_1-O_1$ ,  $C_2-O_2$ , according to the ten-twenty system of the International Federation, Electroenceph. clin. Neurophysiol., 1958, 10: 371-375), two for EOG (left lateral canthus and central forehead), and one frontally located ground (see Fig. 5). This arrangement provides for two central-to-occipital EEG channels and one EOG channel that registers both right-left and up-down eye movements. An example of a recording made from a subject wearing such a cap is shown in Fig. 6.

2. EMG Configuration. In this configuration, two electrodes provide one EEG channel ( $C_2O_2$ ), two provide one EOG channel as above, two located in the chin strap provide one EMG channel, and one acts as a ground. As illustrated in Fig. 7, one EEG channel has been eliminated so that no change in the preamplifier or following stages is necessary. An example of a recording made using such a cap is provided in Fig. 8.

### Preamplifier, Accelerometer, and Control Panel

The preamplifier-accelerometer unit provides initial amplification of the EEG and EOG signals in addition to supplying information regarding motion of the subject's head; this assembly is fastened to the recording cap near the vertex of the head, where minimal interference with the subject's comfort is assured. The amplified signals pass through a 7' cable connected to the control-panel assembly, which provides final amplification of the signals in addition to the necessary subject operational controls and the electrode-test circuitry. These two assemblies (shown in Fig. 1) receive their power from two Powertec model 3D12-1.5 power supplies and a 6.75 V Mallory mercury battery, type TR-135R.

### Circuitry

The preamplifier-accelerometer and the control-panel units are greatly interrelated electronically, therefore the circuit is described here as a single unit. The physical separation of the components is, however, indicated in accompanying diagrams.

Amplification Circuitry. As shown in the schematic (Fig. 9), initial amplification of EEG and EOG signals is accomplished in the preamplifier. Two TIS69s, a matched pair of N-channel field-effect transistors, are arranged in a differential input configuration and accept the unamplified signal from the electrodes. A 2N3707 transistor supplies a constant current to the common-source junction of the two TIS69s to provide improved rejection of common-mode signals which may appear at the inputs. The 100 k  $\Omega$  potentiometer in the base circuit of the 2N3707 is adjusted so that the drain voltage of the TIS69s is approximately +5 V (referred to ground) when both inputs are shorted to ground. Two diodes (GE IN914A) are provided in the common-source circuit of the TIS69s and act in conjunction with the two IN914As in the common drain to prevent flow of current between electrodes during the electrode-testing mode of operation. The initial stage of amplification provides a gain of approximately 10 and supplies a signal of low output impedance to the following stage.

The preamplified EOG, EMG, and EEG signals are led to the amplification circuitry located in the control panel through individually shielded flexible cables. A Fairchild type 741 operational amplifier accomplishes first amplification, and associated filter circuits limit the bandwidth to the specified range. The signals then travel through the 60-Hz line notch filters and the final amplifier with gain control to the mini phone jacks (Fig. 15) to drive high-level external recording devices, then through attenuators to the amphenol connector (Fig. 15) for low-level external recording devices.

Accelerometer Circuitry. As indicated in Fig. 9, a dual-axis accelerometer and associated amplification circuitry are included within the preamplification unit, and these provide information concerning motion of the subject's head. Signals from the accelerometer are amplified by the field-effect transistor (TIS69) and led to the control panel assembly through flexible shielded cable. The accelerometer circuitry is shown in isolated form in Fig. 10A.

The accelerometer and the associated FET are located within a small cylinder (see Fig. 10B, construction view). The accelerometer itself is an Astatic 11T7B stereo crystal cartridge which has been modified by the addition of a 0.08 gm mass at the tip of the recording stylus.

As indicated in Fig. 10C, the accelerometer is oriented within the preamplifier assembly so that its axes of maximal sensitivity are aligned in the vertical (i. e., up-down) and lateral (i. e., side-to-side) directions when the preamplifier is correctly mounted on the recording cap.

Electrode-Test Circuitry. This section performs automatic testing of each recording electrode before the sleep period begins. The control panel, easily visible to the subject during application of the cap, contains a series of indicator lamps, each representing one of the sponge electrode

sensors on the cap. When the cap is donned by the subject, he moves the panel-selector switch from the "off" position to the "test" position, thereby activating the automatic test circuitry. A small test current ( $0-10\mu\text{A}$ ) is passed through the ground electrode to each recording electrode, and this current is sensed to provide an indication of interelectrode resistance. If a given electrode is in proper contact with the scalp, its average resistance will be  $50,000\ \Omega$  or less, and this condition is indicated by illumination of the corresponding lamp in the simulated control-panel display. Improper contact can usually be resolved by slightly rocking the sensor to reposition the sponge through the hair and against the scalp.

Circuit Details. Operation of the electrode-test circuitry is illustrated in Fig. 9. By applying power to the electrode-test circuitry, the input N-channel (FET) in the preamp is connected to the test circuit by the mode switch as shown. All FET drains connect to a common ground through  $1\ \text{M}\Omega$  potentiometers. Each FET gate connects, as usual, to an individual electrode on the recording cap, and the electrodes in turn make contact with the subject's scalp. A single cap electrode serves to ground the subject to the system common ground.

In the normal recording mode the FETs are used as amplifiers, and the drain and source points are always biased positive with respect to ground, thus keeping the gate-source/drain junction reverse-biased, resulting in no significant current flow (high input impedance). In the electrode-testing mode, the astable multivibrator output is connected to the cap ground electrode. When the cap ground electrode goes positive, the FET gate-drain junction is biased in a forward direction, permitting current flow from gate to drain. If the cap ground electrode and the recording electrode are both in contact with the subject's scalp when the cap ground goes positive, current will flow from the cap ground, through the two involved electrodes, across the forward-biased gate-drain junction, and through the  $1\ \text{M}\Omega$  potentiometer in the sensing circuit to signal ground. The amount of current passing through the  $1\ \text{M}\Omega$  resistor, and thus the voltage developed across it, will depend upon the interelectrode impedance ( $R_e$ ) at the scalp. As  $R_e$  becomes lower (i. e., the better the electrode contact), the voltage developed across the sensing resistor increases.

The FET in the sensing circuit, the 2N3820 (FET), detects and amplifies the voltage developed across the  $1\ \text{M}\Omega$  resistance. The amplified voltage serves to turn the following stage, the 2N3702 transistor, fully on when  $R_e$  drops below  $100,000$  (each electrode averages  $50,000\ \Omega$ , indicating adequate scalp-electrode contact). The 2N3702 drives the final stage, 2N2270, which, in turn, operates the panel-indicator lamp for the appropriate recording electrode. A separate sensing circuit exists for each of the 6 recording electrodes, and the indicator lamps are arranged in a display simulating the



cap-electrode configuration, permitting the subject to rapidly identify the faulty electrode. If the common-ground electrode on the cap is at fault, no sensing circuit will operate, and all indicator lamps will be extinguished.

## II. SPECIFICATIONS

### Preamplifier

Input impedance: greater than  $1000 \times 10^6 \Omega$   
 Common-mode signal rejection:  $\sim 60$  dB  
 Frequency response: 0.11 Hz - 40 Hz (-6 dB)  
 Noise level (referred to input):  $3 \mu\text{V}$  peak-to-peak

## III. CONDUCTING A RECORDING SESSION

### Preliminary Preparation

This may be done in the laboratory well before the recording session is to be held to minimize the time required to prepare equipment at the recording site.

1. Connect the power cord to the receptacle on the back of the control panel (Fig. 11), and then plug the cord into a 110 V ac outlet.
2. Plug in the preamplifier cable to the EEG plug receptacle on the front of the control panel (See Fig. 12 and Fig. 1).
3. Attach the shorting connector to the preamplifier plug.

### EEG or EMG Mode

To use the EMG mode, turn the toggle switch on the inside of the front cover to the up position (Fig. 13). This switches channel 2 EEG ( $C_1O_1$ ) to pick up EMG.

To use the EEG mode, the toggle switch should be turned down.

4. Set the Selector switch on the control panel to the check position. All the lamps, which represent the location of the electrodes actually used in the recording cap, should flash.
5. Turn the Selector switch to the run position. Allow the preamplifiers and the power amplifiers to stabilize; this can be checked by observing each channel on a monitor oscilloscope or on an EEG machine.
6. Turn the Selector switch to off; disconnect the shorting plug and the preamplifier from the EEG plug on the control panel.

### Final Preparation

1. Set the recorder and control-panel assembly on a table or the floor next to the subject, with the front of the control facing him. Plug the instrument into a 110 V ac outlet.
2. Either prepare for bed (if a sleep recording is to be done), or settle comfortably in the environment where the recording takes place.
3. Remove the sleep cap from the plastic bag, and attach the preamplifier to the vertex of the cap as in Fig. 1.
4. Attach the preamplifier cable to the control-panel assembly (as in Fig. 1).
5. Carefully prepare the sponge electrodes by clipping the sealing tab off each electrode (Fig. 14). It may be necessary to cut off a little more than just the tab at the junction of the conical part of the sponge to obtain satisfactory scalp/electrode contact.
6. Put the cap on and secure the chin strap (it should be comfortably snug).

### Use of EMG Cap

The EMG cap differs from the standard (M133 configuration) cap in that it has two additional electrodes in the chin strap, EMG 1 and EMG 2. These electrodes should be filled with electrolyte in the same manner as the other electrodes. When fastening the chin strap, be sure that these electrodes are centered as much as possible. There is ample velcro at either end of the chin strap for length adjustment.

Great care should be used in adjusting the length on the left side where the wires leading to the EMG electrodes are attached.

**TO LENGTHEN:** gently pull out the slack created by looping the EMG wires loosely on the left side of the cap.

**TO SHORTEN:** gently increase the slack in the EMG wires on the left side of the cap.

**NEVER JERK THE WIRES** while adjusting the chin-strap length.

The chin strap should be comfortably snug with all electrodes in good contact with the skin. Check these electrodes on the control panel along with the others during the electrode-check procedure.

7. If it is a sleep recording, get into bed; if it is not a sleep recording, assume a comfortable position.

8. Turn the Selector switch on the control panel to the check position (Fig. 11). Rock each electrode slightly to position the exposed sponge tip against the scalp through the hair. Correct contact is verified by illumination of the red lamps on the control panel (Fig. 11) which correspond to the arrangement of electrodes on the cap.

9. Turn the Selector switch to run. If it is necessary to get up during recording, simply disconnect the preamplifier cable from the control panel and let the recorder continue running. Upon returning, again connect the cable to the recorder and repeat step 8. Then switch to run and continue as before. NEVER unplug the control panel from the wall socket during a recording period.

10. At the end of the recording period, turn the Selector switch to the check position to determine if all the electrodes are still in proper contact.

11. Turn the Selector switch to the off position, and disconnect the preamplifier cable from the control panel.

12. Remove the cap and disconnect the preamplifier.

In numerous laboratory trials, it has been determined that the entire preparation procedure as outlined above can easily be accomplished by the subject himself in 3-5 min. Post-recording "breakdown" time is only about 1 min, since it is only necessary for the subject to remove the cap.

### Use With External Recording/Reproducing Devices

The output mini phone jacks shown in Fig. 15 are single ended. These are used to drive external devices such as tape recorders, oscilloscopes, or high-level Dynograph recorders. A signal of  $\pm 1$  V rms (2.8 V p-p) at these jacks corresponds to a  $\pm 200 \mu$ V input signal to the preamplifier.

The amphenol connector #126-221 shown in Fig. 15 is single ended. The signals to this connector come from the mini phone jacks through attenuators for low-level output. These attenuators are set so the overall gain of the system is one, thereby permitting direct connection to the high-gain inputs of recording devices (for example, an EEG machine headboard).

## IV. MAINTENANCE

### Storage and Care of Recording Caps

New caps with filled and sealed electrodes can be stored on the shelf at room temperature for up to 2 months as long as the bag remains sealed. After 2 months or after the caps have been used, they must be prepared as outlined below and placed under refrigeration. With proper care they can be reused many times.

1. Wash the cap in lukewarm water and pHisoHex, being sure to wash out all electrolyte that may be on the cap material.
2. Rinse well in water.
3. Wrap in a towel for a few minutes (do not wring or shake).
4. Place on a clean towel and air dry. (This should take 2-3 hours.)
5. When the cap is dry, insert a small amount of electrolyte in each electrode (see procedure below), checking each electrode as it is filled for cracks in the vinyl coating and/or breaks in the wires of insulation.
6. Place a damp square of gauze over the cut end of each electrode, seal the cap in a vinyl bag, and refrigerate. If the cap is not used within 2 weeks, remove it, check it, refill it with electrolyte, and refrigerate again.

### Refilling Electrodes with Electrolyte

Use a syringe with a 20-gauge hypodermic needle. Fill the syringe (without the needle attached) with electrolyte solution (KM-137), plunging the syringe deep into the solution so that no air bubbles are sucked in with the solution. If the syringe contains air bubbles, empty it and refill it. Wipe the outside of the syringe and fasten the needle in place.

Check each electrode for cracks before filling. Insert the needle straight down, well into the sponge portion of the electrode. Slowly inject electrolyte until the sponge is full but not overflowing onto the cap. Place a small square of moist gauze over each electrode opening.

Reference is made to the report of the

of the Commission on the subject of the  
of the Commission on the subject of the  
of the Commission on the subject of the  
of the Commission on the subject of the

of the Commission on the subject of the  
of the Commission on the subject of the  
of the Commission on the subject of the  
of the Commission on the subject of the

V. FIGURES

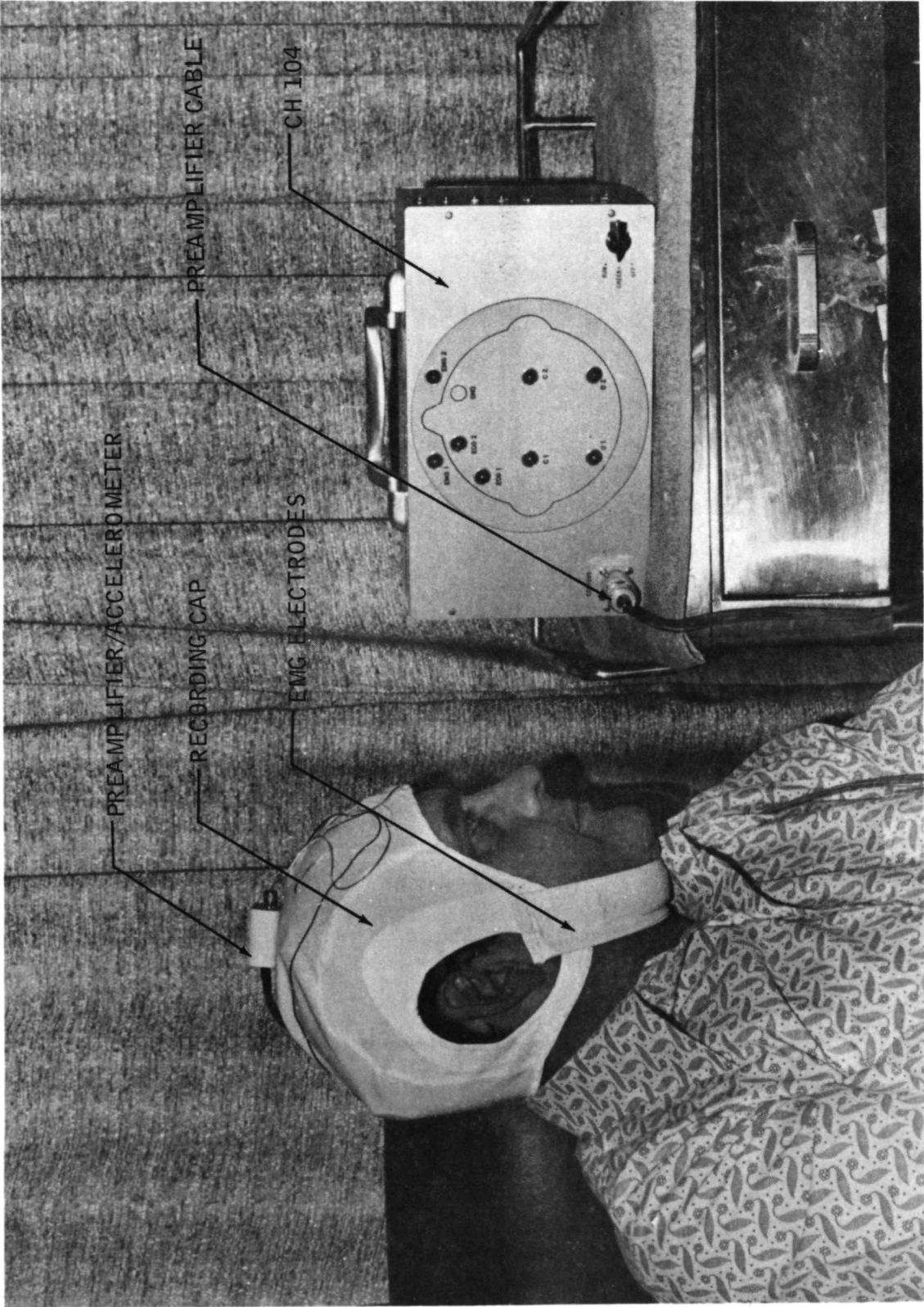

FIGURE 1. - CH 104 NEUROPHYSIOLOGICAL MONITORING ASSEMBLY

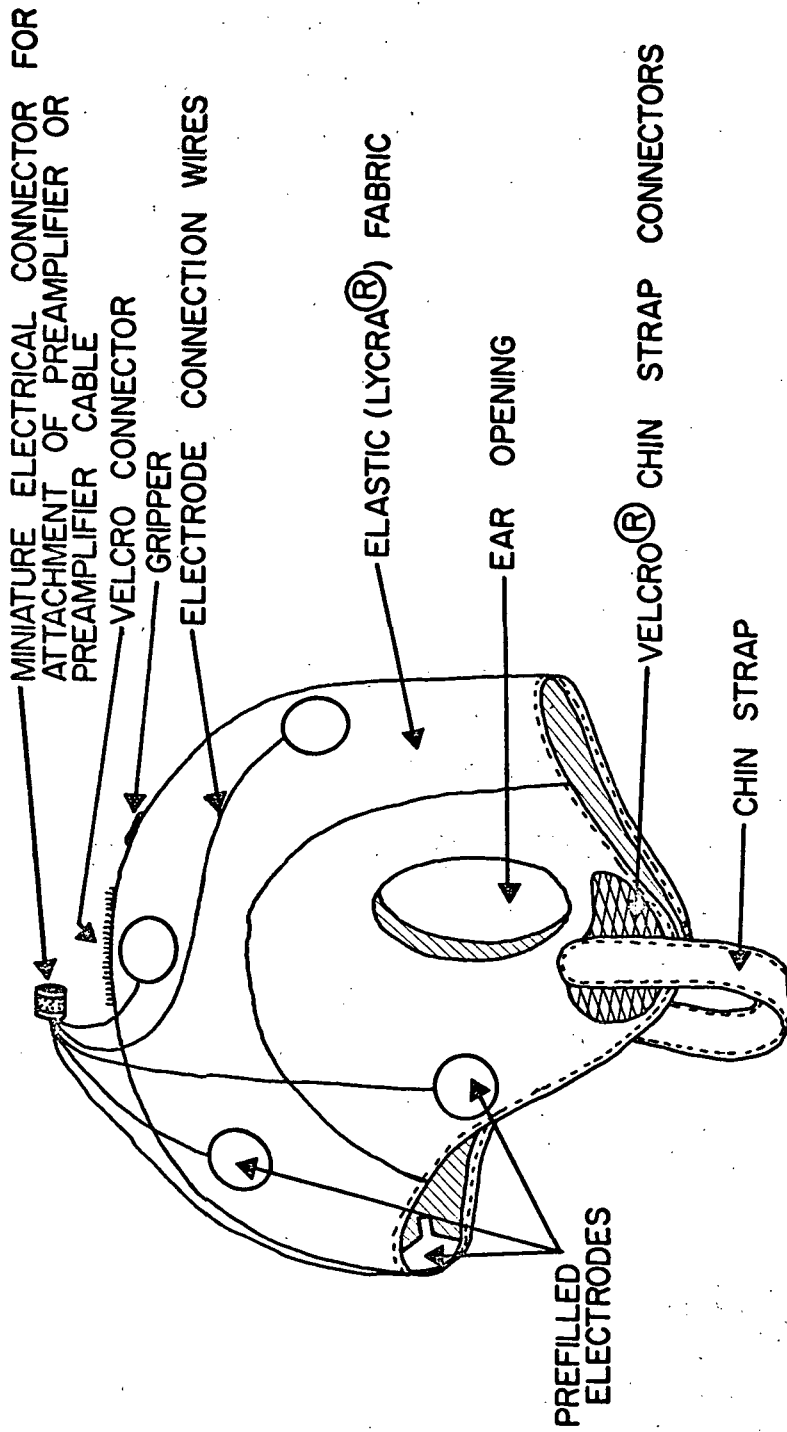

FIGURE 2. - EEG RECORDING CAP



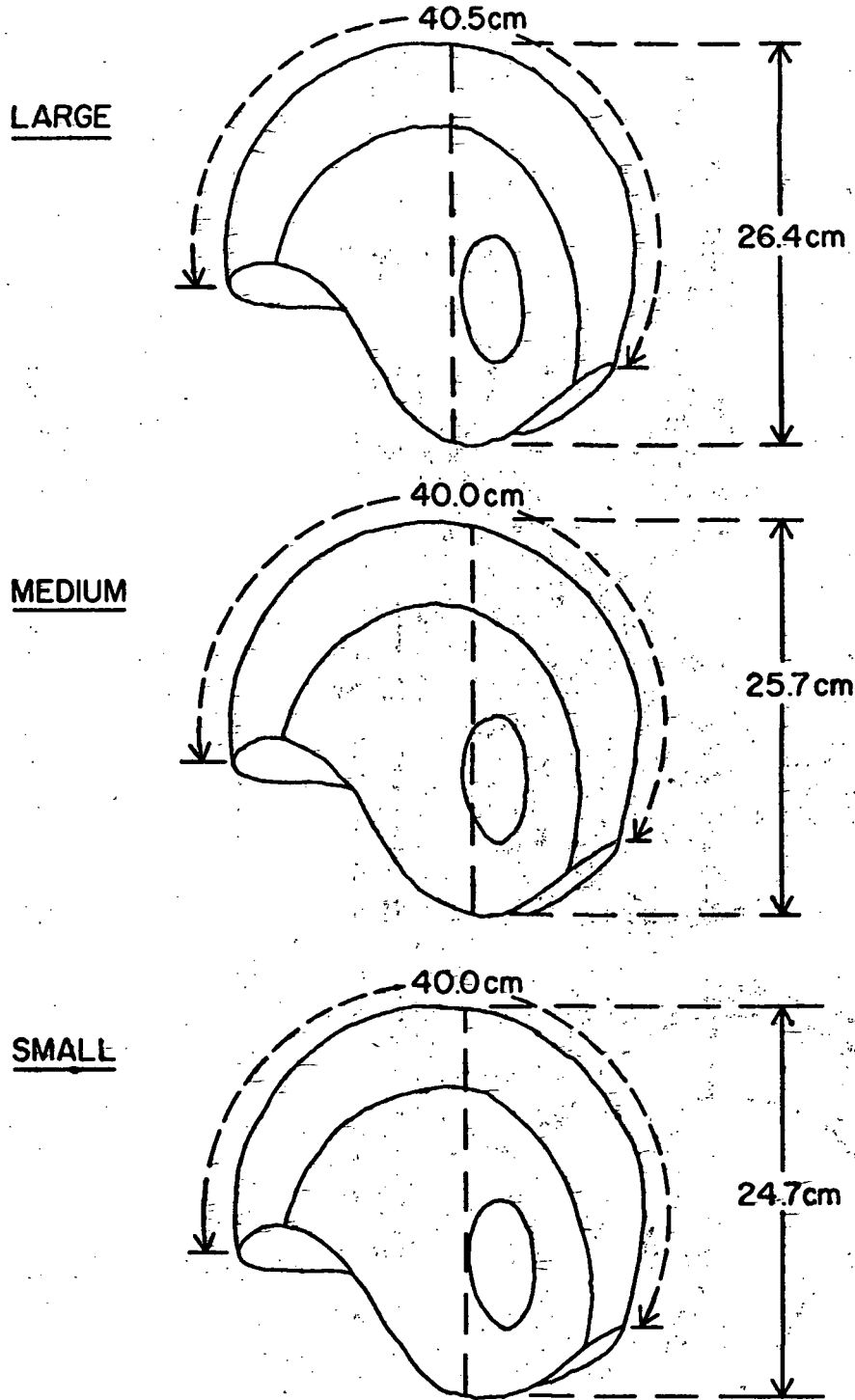

FIGURE 3. - COMPARISON OF CAP SIZES

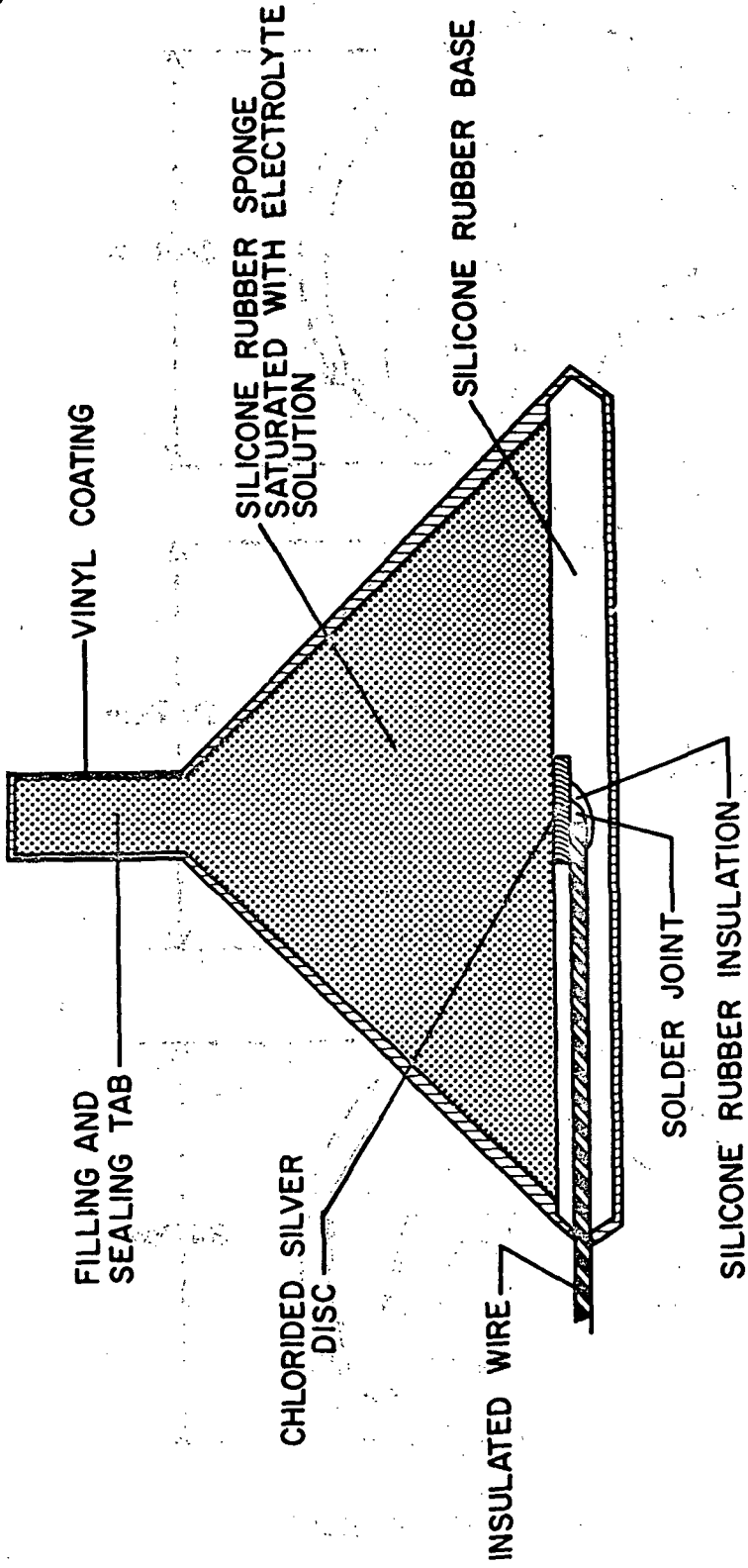

FIGURE 4. - CROSS SECTION OF PREFILLED SPONGE ELECTRODE

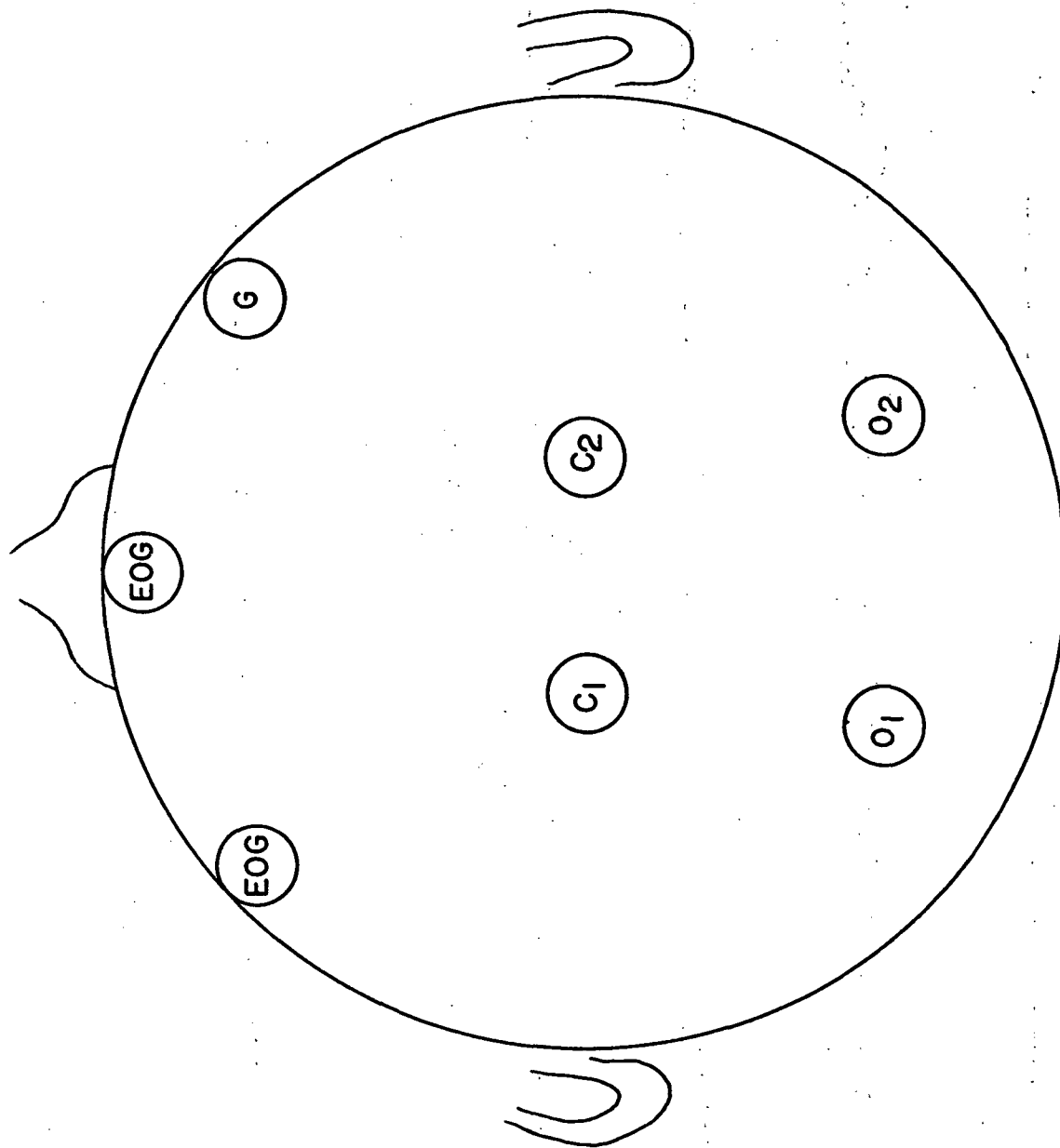

FIGURE 5. - STANDARD CAP ELECTRODE POSITIONS

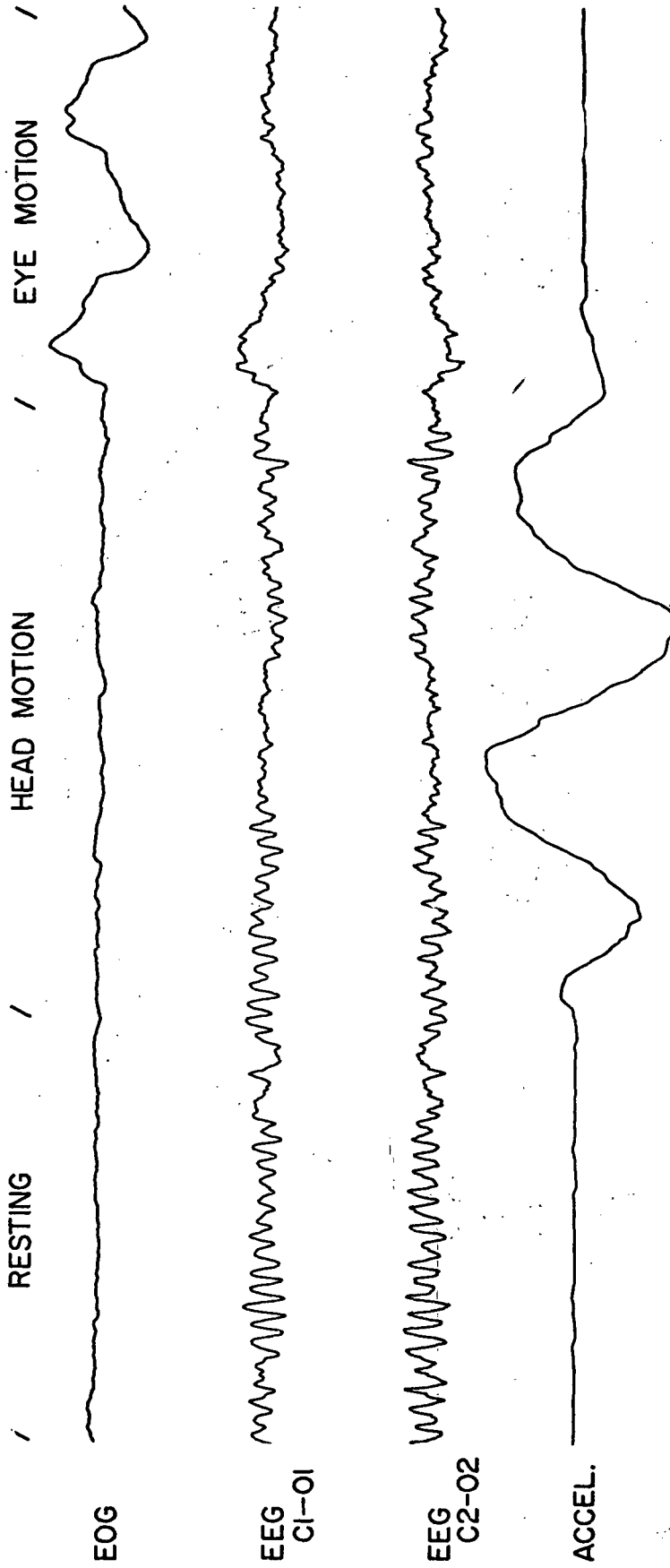

FIGURE 6. - EEG, EOG, ACCELEROMETER FROM STANDARD ELECTRODE CAPS

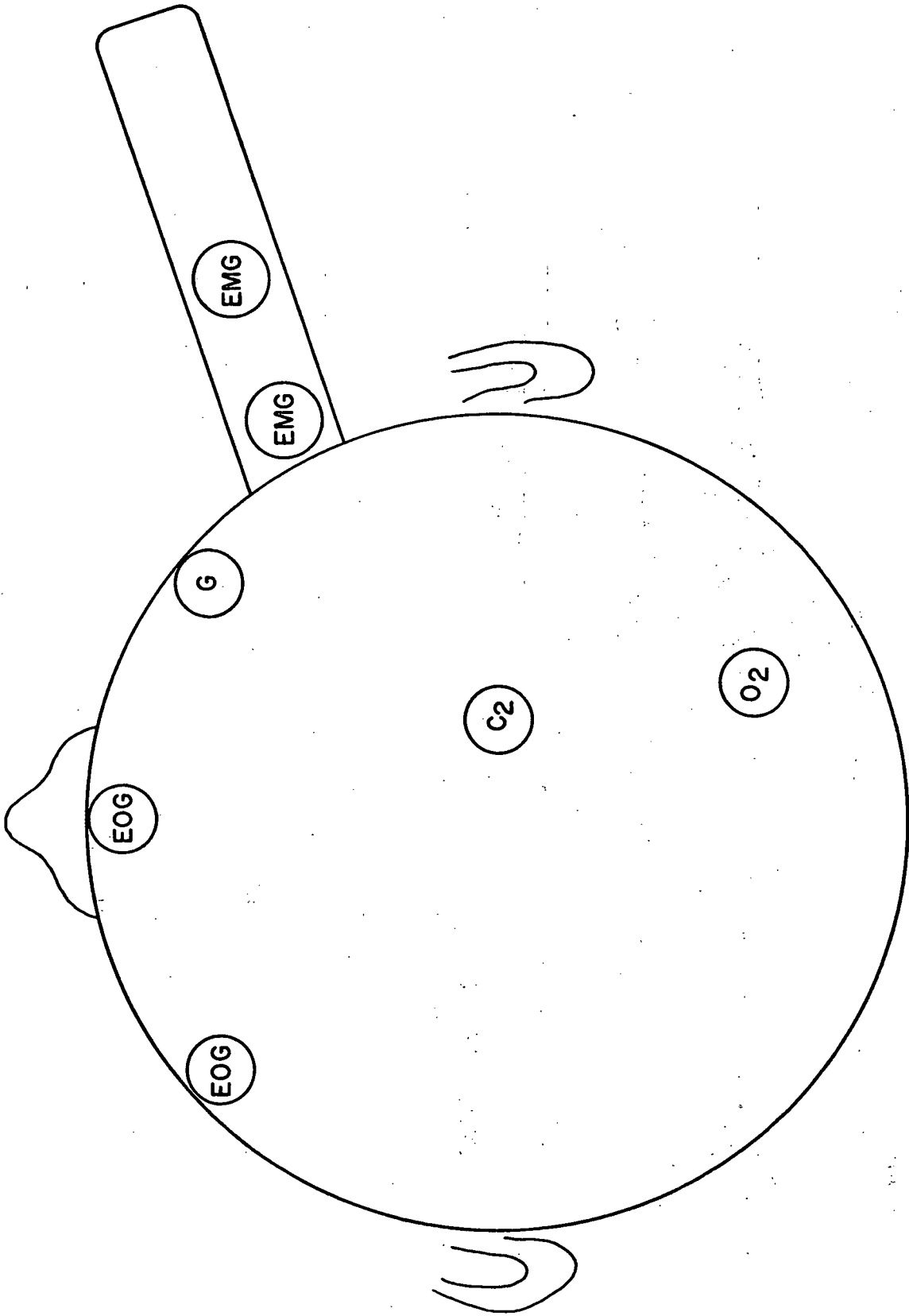

FIGURE 7. - EMG CAP ELECTRODE POSITIONS

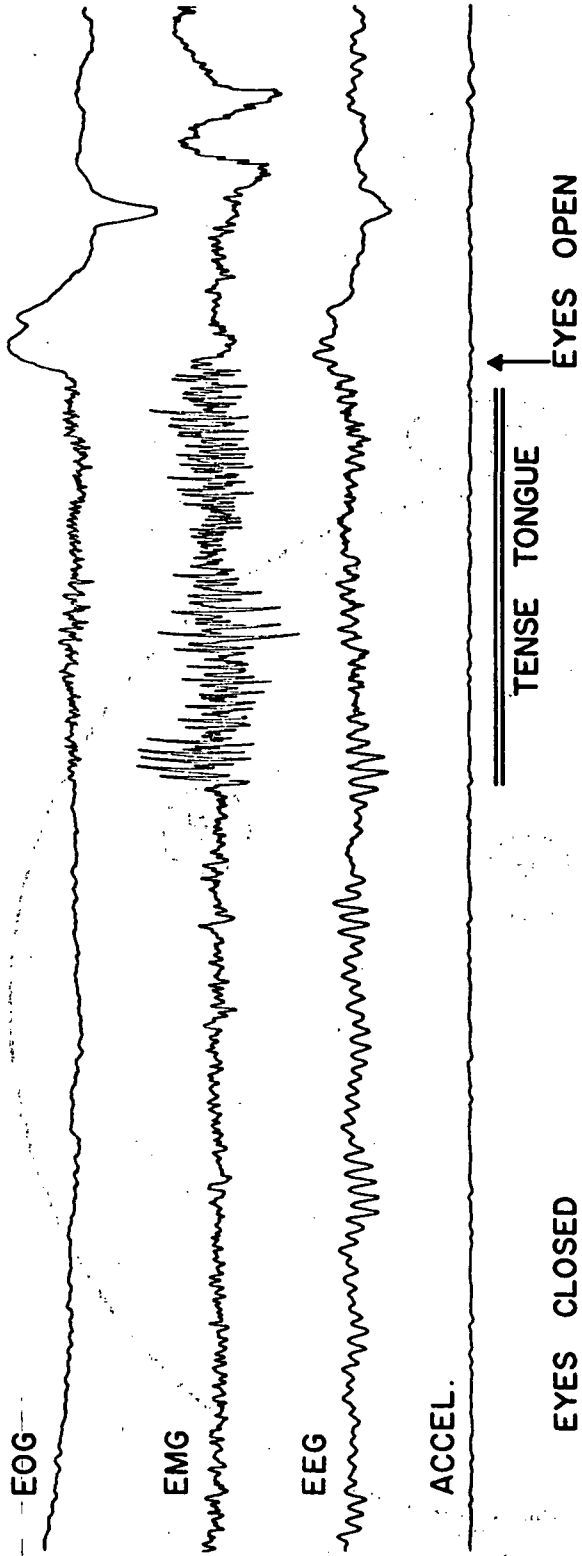

FIGURE 8. - EXAMPLE OF CH104 RECORDING WITH EMG CAP CONFIGURATION.

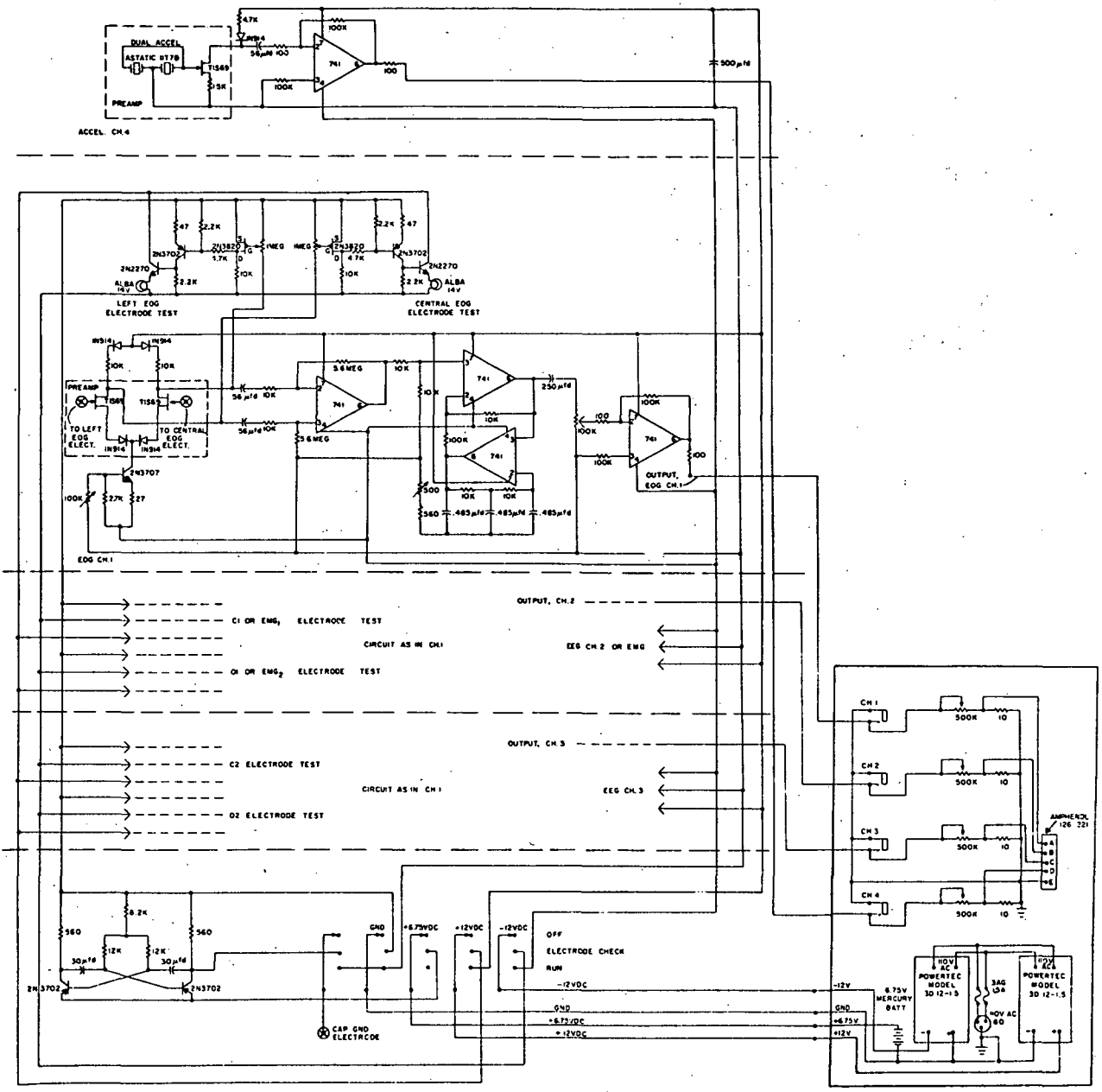
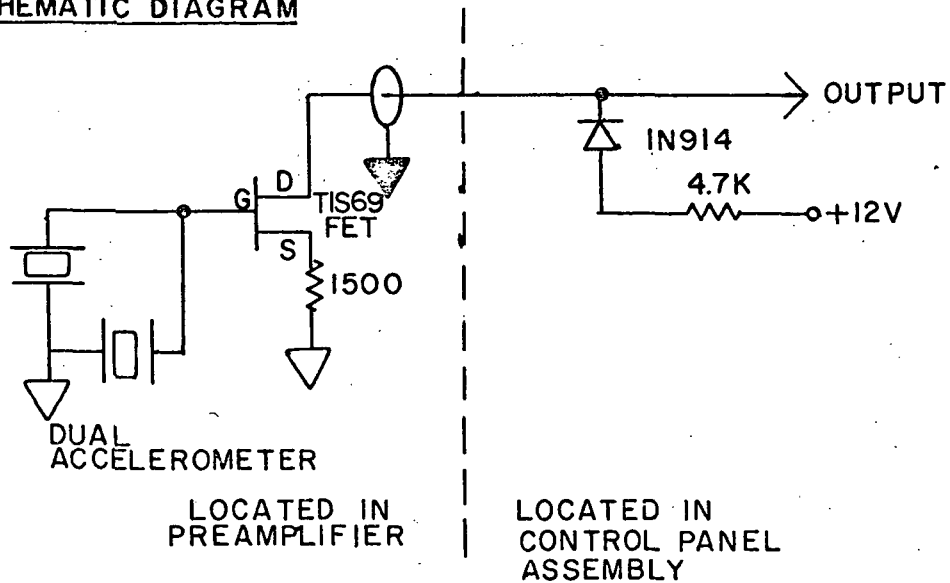
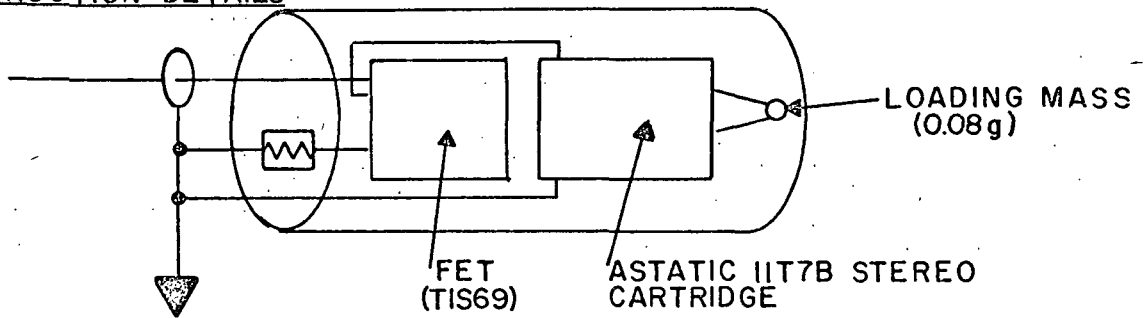

FIGURE 9. - ELECTRODE-TEST CIRCUITRY SCHEMATIC DIAGRAM.

**A. SCHEMATIC DIAGRAM**



**B. CONSTRUCTION DETAILS**



**C. ORIENTATION OF ACCELEROMETER AXES**

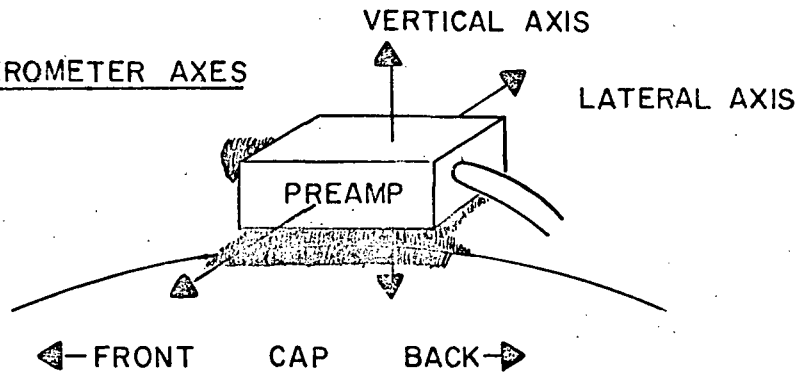

FIGURE 10. - DUAL ACCELEROMETER



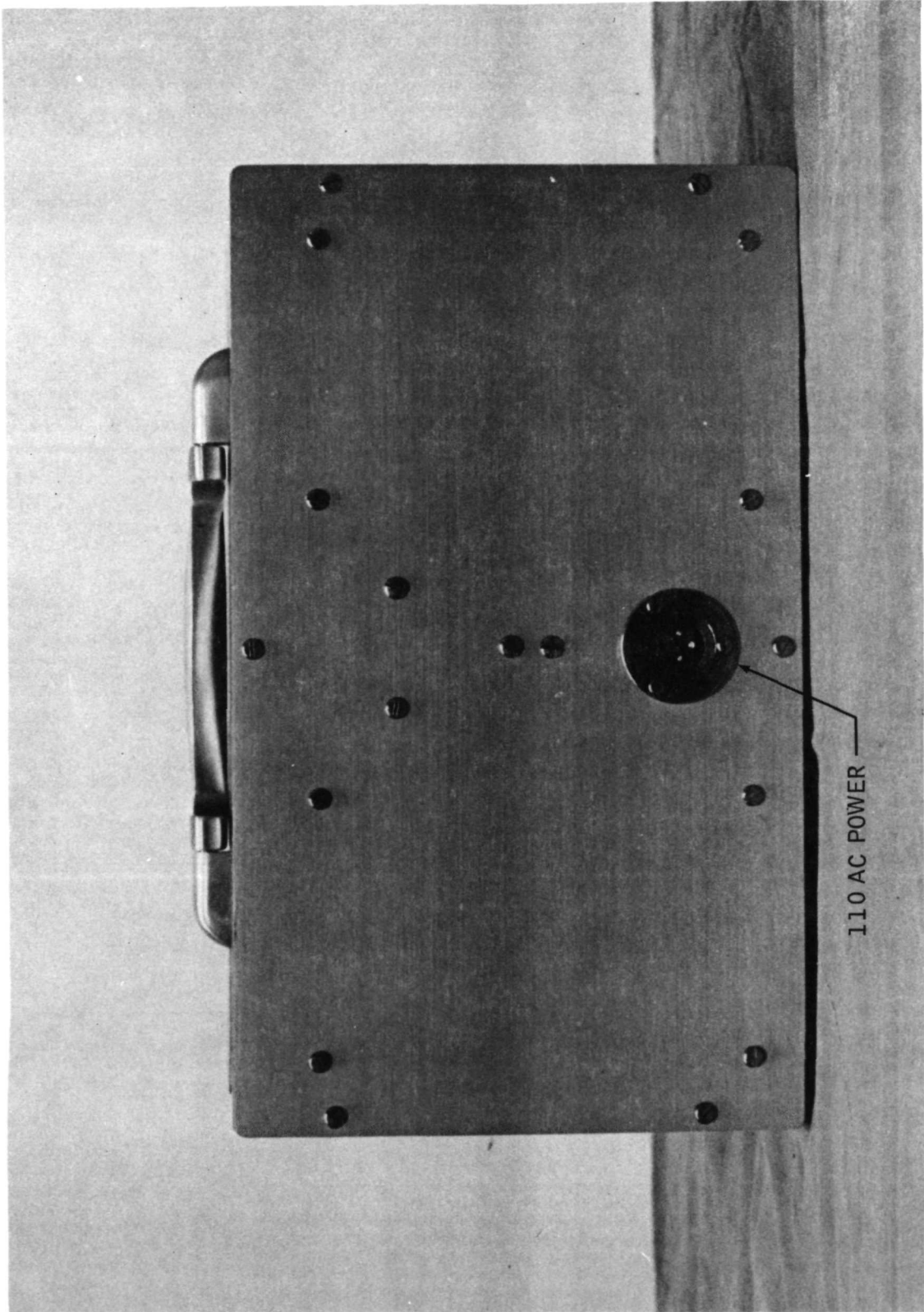

FIGURE 11. - BACK OF CONTROL PANEL ASSEMBLY

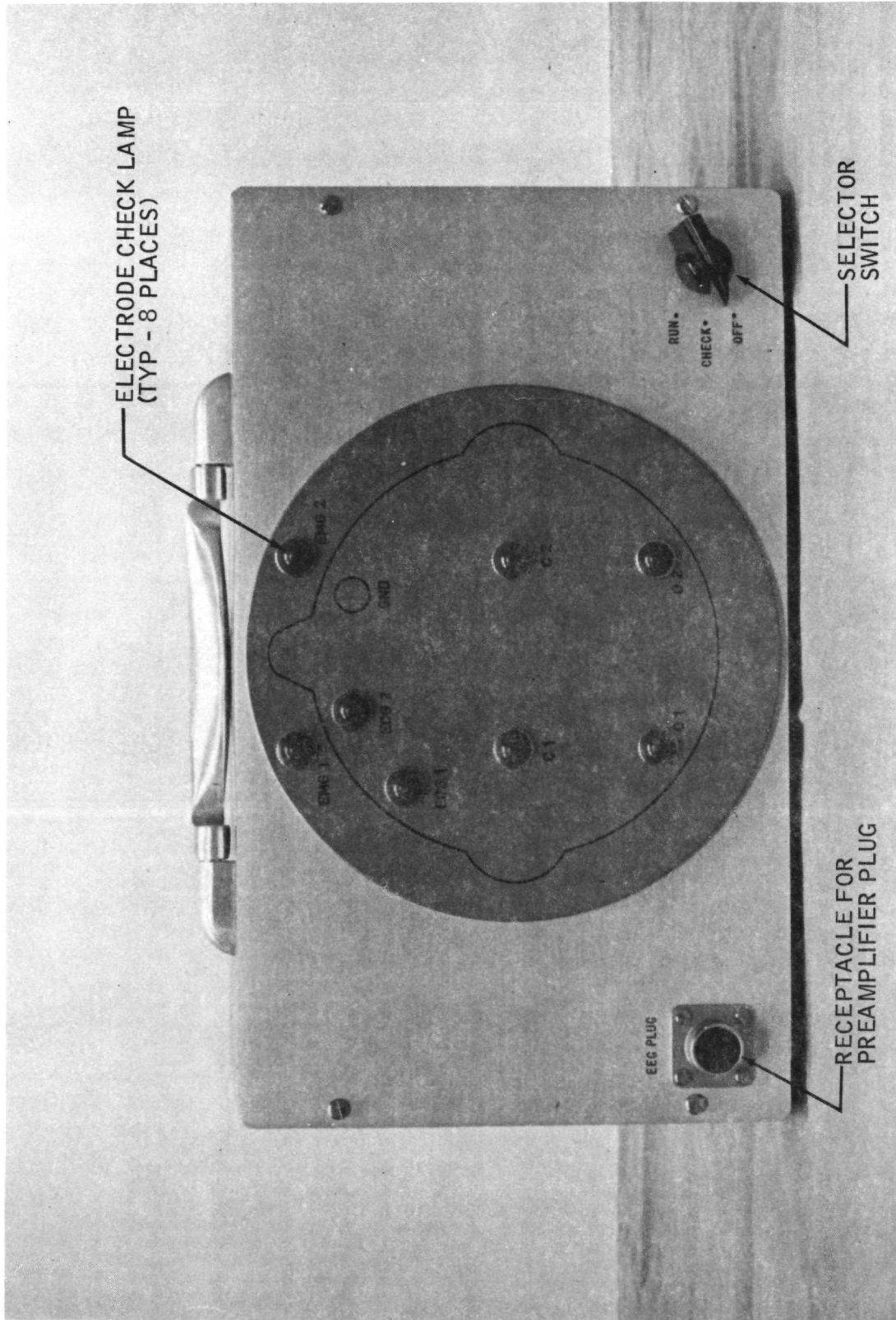

FIGURE 12. - FRONT OF CONTROL PANEL ASSEMBLY

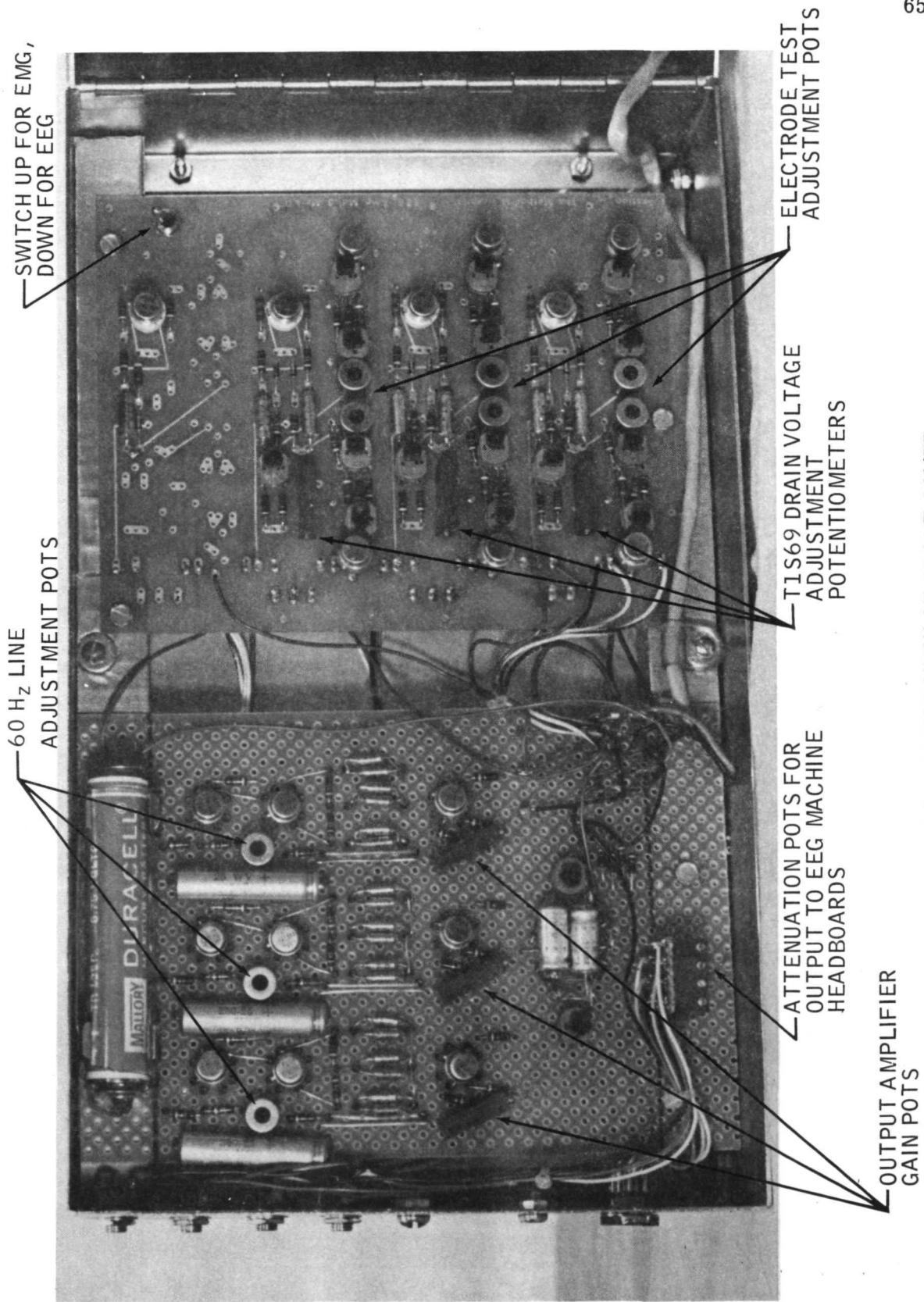
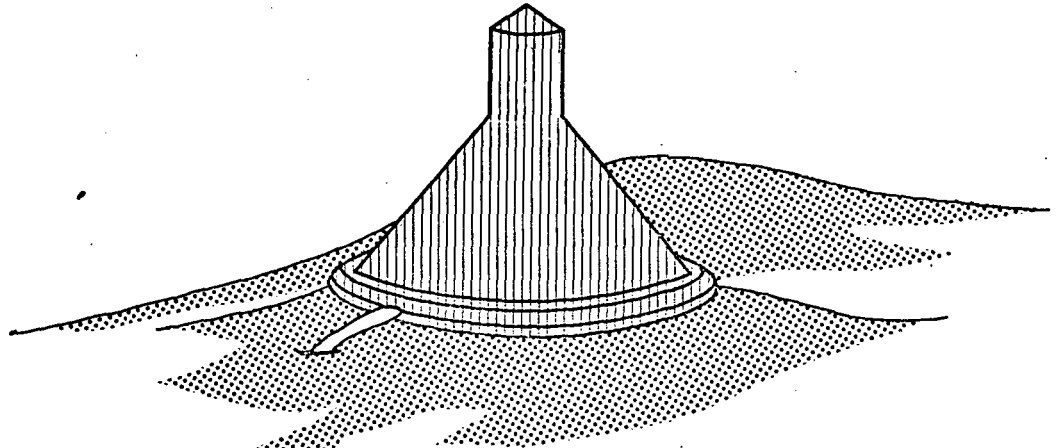
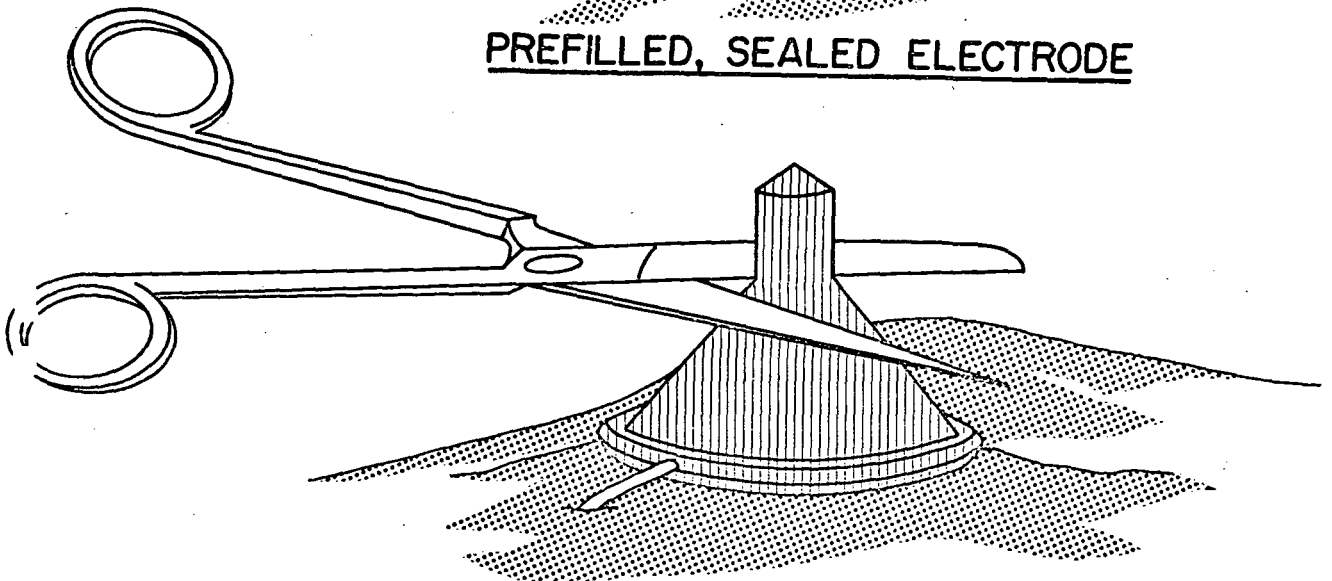

FIGURE 13. - INSIDE VIEW OF FRONT COVER



PREFILLED, SEALED ELECTRODE



REMOVAL OF SEALING TAB

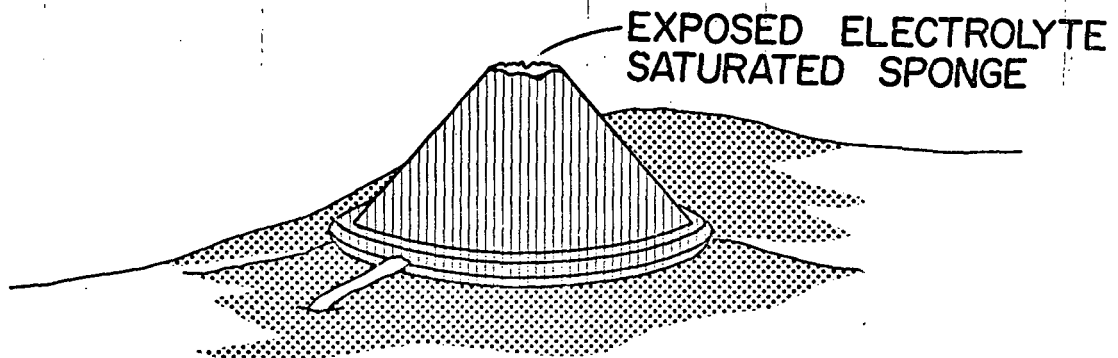

PREPARED ELECTRODE

FIGURE 14. - PREPARATION OF ELECTRODE FOR USE.

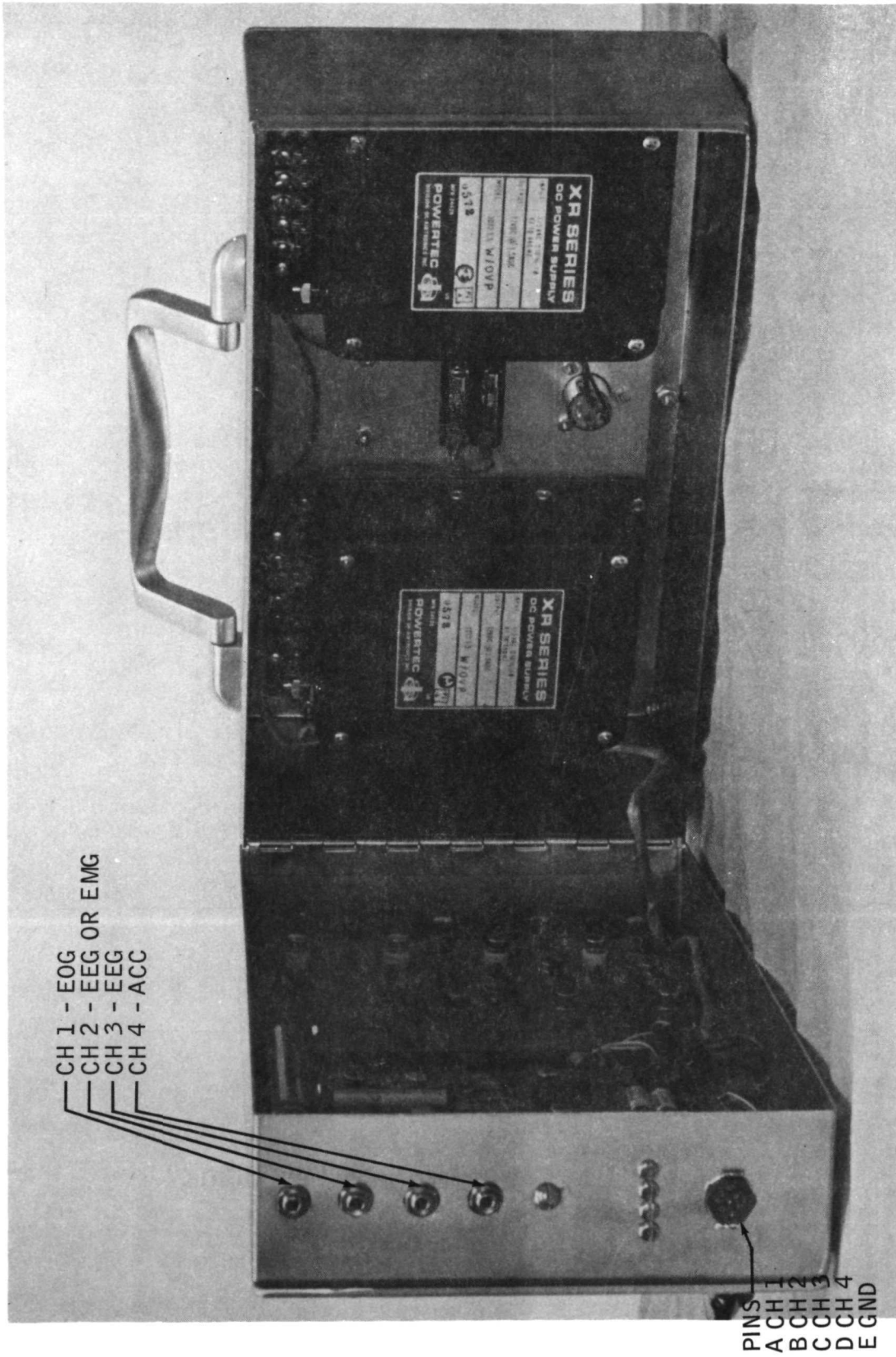

FIGURE 15. - VIEW SHOWING OUTPUT JACKS

**Page Intentionally Left Blank**

NATIONAL AERONAUTICS AND SPACE ADMINISTRATION  
WASHINGTON, D.C. 20546

OFFICIAL BUSINESS  
PENALTY FOR PRIVATE USE \$300

**SPECIAL FOURTH-CLASS RATE  
BOOK**

POSTAGE AND FEES PAID  
NATIONAL AERONAUTICS AND  
SPACE ADMINISTRATION  
451



POSTMASTER: If Undeliverable (Section 158  
Postal Manual) Do Not Return

*"The aeronautical and space activities of the United States shall be conducted so as to contribute . . . to the expansion of human knowledge of phenomena in the atmosphere and space. The Administration shall provide for the widest practicable and appropriate dissemination of information concerning its activities and the results thereof."*

—NATIONAL AERONAUTICS AND SPACE ACT OF 1958

## NASA SCIENTIFIC AND TECHNICAL PUBLICATIONS

**TECHNICAL REPORTS:** Scientific and technical information considered important, complete, and a lasting contribution to existing knowledge.

**TECHNICAL NOTES:** Information less broad in scope but nevertheless of importance as a contribution to existing knowledge.

**TECHNICAL MEMORANDUMS:** Information receiving limited distribution because of preliminary data, security classification, or other reasons. Also includes conference proceedings with either limited or unlimited distribution.

**CONTRACTOR REPORTS:** Scientific and technical information generated under a NASA contract or grant and considered an important contribution to existing knowledge.

**TECHNICAL TRANSLATIONS:** Information published in a foreign language considered to merit NASA distribution in English.

**SPECIAL PUBLICATIONS:** Information derived from or of value to NASA activities. Publications include final reports of major projects, monographs, data compilations, handbooks, sourcebooks, and special bibliographies.

**TECHNOLOGY UTILIZATION PUBLICATIONS:** Information on technology used by NASA that may be of particular interest in commercial and other non-aerospace applications. Publications include Tech Briefs, Technology Utilization Reports and Technology Surveys.

*Details on the availability of these publications may be obtained from:*

**SCIENTIFIC AND TECHNICAL INFORMATION OFFICE**

**NATIONAL AERONAUTICS AND SPACE ADMINISTRATION**

**Washington, D.C. 20546**