

FINAL REPORT DRAW FORMING OF SCALE SHUTTLE EXTERNAL TANK DOME GORES

May 1974

By: G. GARFIELD

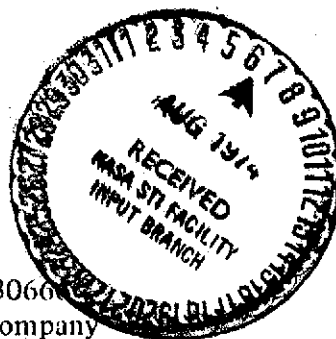

Prepared under Contract NAS8-3066
McDonnell Douglas Astronautics Company
5301 Bolsa Avenue
Huntington Beach, California 92647

for

GEORGE C. MARSHALL SPACE FLIGHT CENTER
HUNTSVILLE, ALABAMA 35812

(NASA-CR-120311) DRAW FORMING OF SCALE
SHUTTLE EXTERNAL TANK DOME GORES Final
Report, 1 Mar. - 15 May 1974
(McDonnell-Douglas Astronautics Co.) 32 P
HC \$4.75 CSCL 13H G3/15 54597 Unclas

N74-29930

**FINAL REPORT
DRAW FORMING OF SCALE
SHUTTLE EXTERNAL TANK DOME GORES**

May 1974

By: G. GARFIELD

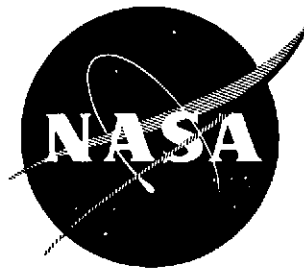

Prepared under Contract NAS8-30666
McDonnell Douglas Astronautics Company
5301 Bolsa Avenue
Huntington Beach, California 92647

for

GEORGE C. MARSHALL SPACE FLIGHT CENTER
HUNTSVILLE, ALABAMA 35812

ABSTRACT

This document presents a description of Phase I work to manufacture, document, and deliver subscale critical sections of the External Tank Dome Gores and of Phase II work to prepare preliminary die design for the full-scale dome gores.

Highlights of the Phase II work include:

- Test work performed to determine press tonnage requirements
- Draw die to fit an available press
- Manufacturing plan including tool concepts for the entire production sequence

PRECEDING PAGE BLANK NOT FILMED

FOREWORD AND ACKNOWLEDGMENTS

This report was prepared by the McDonnell Douglas Astronautics Company (MDAC), Huntington Beach, California, in compliance with Contract NAS8-30666. This final report describes work completed in the work from 1 March 1974 to 15 May 1974. This program is sponsored by the National Aeronautics and Space Administration's George C. Marshall Space Flight Center, Huntsville, Alabama. Mr. Robert Shankle is the contracting officer, Mr. E. J. Minter principal representative and Mr. V. H. Yost alternate representative.

The following McDonnell Douglas Corporation personnel were the principal contributors to this program: Mr. J. Y. Kumagai, Assistant Project Supervisor; R. D. Glick, Die Design; E. A. Grant, Manufacturing Plan; G. A. Hill, Producibility; and G. Garfield, Project Supervisor.

PRECEDING PAGE BLANK NOT FILMED

CONTENTS

Section 1	INTRODUCTION AND SUMMARY	1
Section 2	FABRICATION OF SUBSCALE DOME GORES	3
	2.1 Material Preparation	3
	2.2 Forming	3
Section 3	TEST FIXTURE	7
	3.1 Test Fixture for Press Tonnage Determination	7
	3.2 Fixture Description	7
	3.3 Test Procedure	7
Section 4	DRAW FORMING DIE	11
	4.1 Die Design	11
	4.2 Die Material	11
	4.3 Die Additions for LO ₂ Gores	14
	4.4 Alternate Press	14
	4.5 Press Tonnage	14
	4.6 Gores that Go with a 180-Inch Diameter Cap	14
Section 5	MANUFACTURING	17
	5.1 Manufacturing Plan	17
	5.2 Forming	17
	5.3 Trimming	17
	5.4 Cleaning	17
	5.5 Heat Treating	17
	5.6 Chem Milling	19
	5.7 Shipping	
Section 6	TOOLING	21

FIGURES

2-1	Material Layout for Draw Forming Subscale Gores	4
2-2	View Showing Die in Press	5
2-3	View Showing 4 Percent and 2-1/2 Percent Subscale Gores	5
3-1	Test Fixture for Press Tonnage Determination	8
3-2	View Showing Test Fixture in Tensile Tester	9
3-3	View Showing Test Coupons Before and After Test	9
4-1	Preliminary Die Design for 12- and 9-Gore Configuration	12
4-2	Hydraulic Press, 5,000 Ton	13
5-1	Gore Fabrication Production Flow Chart	18
6-1	Hoist Handling Fixture HHF1 No. 1	22
6-2	Hoist Handling Fixture HHF2 No. 2	22
6-3	Hoist Handling Fixture HHF3 No. 1	23
6-4	Contour Check Fixture	23
6-5	Trim Fixture	24
6-6	Heat Treat Fixture	24
6-7	Shipping Container	25

TABLES

2-1	Forming Record-Subscale Gores	6
4-1	LH ₂ Gores 0.187-Inch Thick 2219-T-37 Aluminum	15

PRECEDING PAGE BLANK NOT FILMED

Section 1
INTRODUCTION AND SUMMARY

This report presents a description of the fabrication effort accomplished in Phase I and the results of die design accomplished in Phase II.

The objective of Phase I was to draw-form critical subscale sections of the dome gores and ship them to MSFC for test and evaluation.

The objective of Phase II was to perform certain tests to ascertain minimum press tonnage requirements for forming full-size gores on an available press, determine the least number of gores per External Tank dome which can be produced by the draw-form method, to prepare a manufacturing plan

In Phase I, six subscale gores were formed to a 2.5 percent biaxial elongation and six subscale gores were formed to a 4 percent biaxial elongation. The formed parts were shipped to MSFC.

In Phase II it was determined that the least gore configuration was nine gores per dome because of the available clearance between columns of the press. It was also determined that full-scale gores that go with a 140-inch cap in accordance with MMC Drawing 82600202001 could not be draw-formed on the available press because of the excessive overhang of the die in the press.

The manufacturing plan presented here is based on the current state-of-the-art with predictable manufacturing rates.

Section 2
FABRICATION OF SUBSCALE DOME GORES

2.1 MATERIAL PREPARATION

Two sheets, 0.250 by 48 by 120 inch 2219-T37 aluminum were scribed and identified as shown on Figure 2-1 and the 27-inch-diameter circles and the 20.7 by 30.0 inch rectangles were cut out.

2.2 FORMING

Six blanks marked A1 through A6 were drawn in a die to a 2-1/2 percent biaxial elongation as measured on the diametral increase on 2- and 4-inch-diameter circles.

The 2-1/2 percent was determined by deducting the chord length of a gore which would be required to make a nine-gore dome from 1/9 of the circumference of the 330.2-inch dome diameter, per MMC drawing 82600202000 plus 1/2-inch springback overforming allowance, multiplying the difference by 100 and dividing the result by the chord length.

Six blanks marked B1 through B6 were drawn in a die to a 4 percent biaxial elongation as measured on the diametral increase on 2-, 4-, and 6-inch diameter circles. The 4 percent figure was determined by adding 1-1/2 percent to the previously determined 2-1/2 percent per contract requirement.

The die, which forms an 8.53-inch spherical inside radius was mounted in a 650-ton HPM hydropress as shown in Figure 2-2. The cushion pressure was set at 70 tons, based on experience, to prevent the blank from shrinking. To obtain a 2-1/2 percent elongation, the draw depth was determined to be approximately 0.9 inch and to obtain a 4 percent elongation the draw depth was determined to be approximately 1.57 inches.

Forming rate was 4 inches per minute to enable press operator to terminate the draw at a repetitive point. A comparison of blanks drawn to 2-1/2 percent and 4 percent are shown in Figure 2-3.

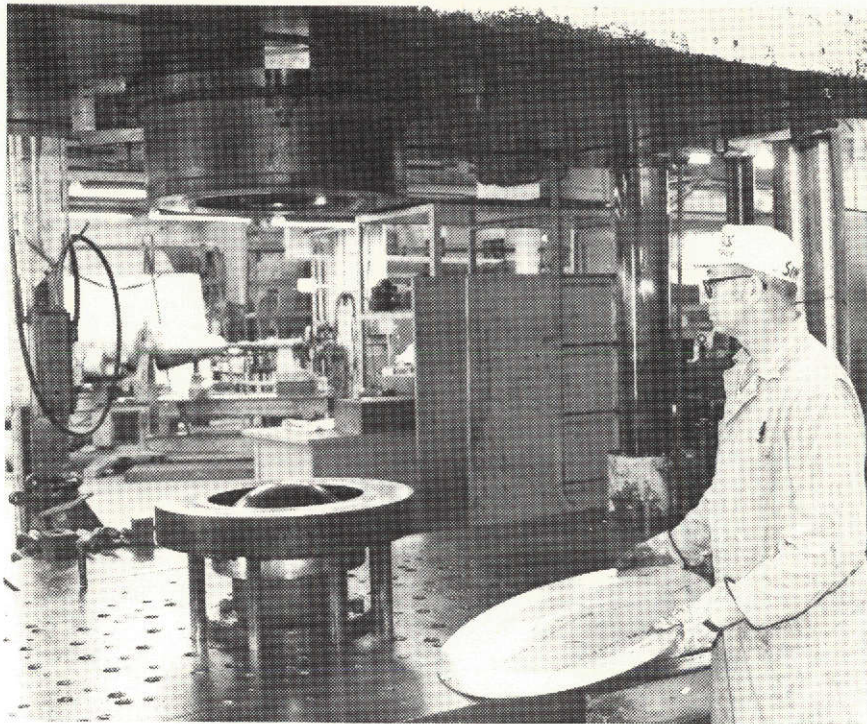

Figure 2-2. View Showing Die in Press

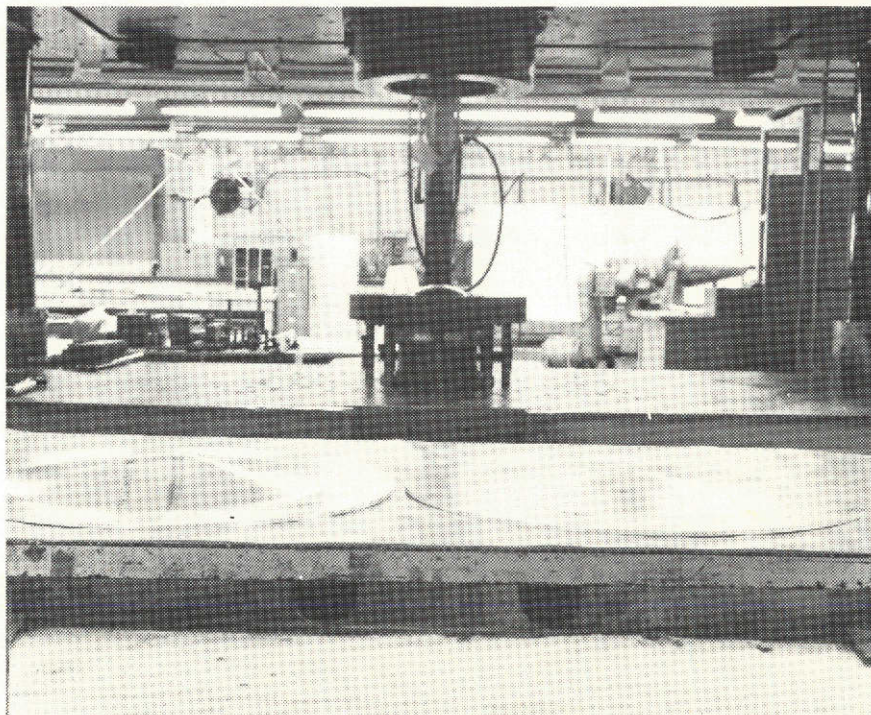
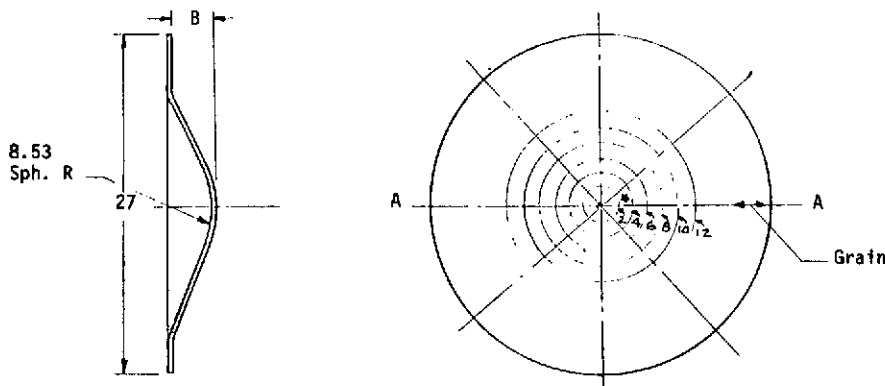

Figure 2-3. View Showing 4 Percent and 2-1/2 Percent Subscale Gores

Measured changes in circle diameters and material thickness are shown in Table 2-1.

Table 2-1
FORMING RECORD - SUBSCALE GORES



Ram pressure 140 tons
Hold down pressure 70 tons
Forming rate 4 in/min

Blank No.	A-1	A-2	A-3	A-4	A-5	A-6	B-1	B-2	B-3	B-4	B-5	B-6
Elongation (%)												
Within 4 in. dia circle	2.6	2.5	2.6	2.6	2.5	2.8						
Within 6 in. dia circle							4.0	4.1	4.0	4.1	4.0	3.9
Depth of Draw B	0.90	0.91	0.89	0.90	0.88	1.1	1.54	1.59	1.58	1.57	1.57	1.50
Material Thickness at * 3 in. dia												
Before draw	0.246	0.246	0.249	0.247	0.248	0.247	0.247	0.247	0.247	0.247	0.247	0.247
After draw	0.241	0.242	0.243	0.241	0.242	0.241	0.237	0.237	0.236	0.238	0.237	0.236
Measured dia on C/L A-A												
At 2-in. circle BD	2.000	2.000	2.000	2.000	1.995	1.995	2.000	2.000	1.995	2.000	2.000	1.995
At 2-in. circle AD	2.050	2.050	2.050	2.050	2.040	2.050	2.070	2.075	2.070	2.075	2.075	2.070
At 4-in. circle BD	3.990	3.995	3.995	3.995	3.975	3.995	4.000	3.995	3.995	3.995	3.995	3.995
At 4-in. circle AD	4.105	4.105	4.100	4.110	4.080	4.120	4.160	4.160	4.160	4.160	4.155	4.155
At 6-in. circle BD							6.000	6.000	6.000	6.000	6.000	6.000
At 6-in. circle AD							6.240	6.250	6.240	6.250	6.240	6.230
No. of draws	1	1	1	1	1	2	1	1	1	1	1	3

PHASE II

7

Section 3 TEST FIXTURE

3.1 TEST FIXTURE FOR PRESS TONNAGE DETERMINATION

A special fixture was constructed to simulate full scale die blank holding characteristics. Figure 3-1 shows the details and assembly of the test fixture. The fixture was designed to accept 0.250-inch-thick test coupons. Coupon dimensions are shown in the lower portions of Figure 2-1.

3.2 FIXTURE DESCRIPTION

The fixture preforms coupons to a draw bead configuration by forcing punch (-7) into die (-3). The force is supplied by hydraulic cylinder (-15) which receives its pressure from hand pump (-17). The cylinder is backed up by plate (-1) which is coupled to die by tension rods (-11). A 0 to 10,000 psi gage graduated in 100-psi increments was used to determine internal pressure. The cylinder bore has an effective area of 4.439 in.².

3.3 TEST PROCEDURE

Fixture was attached to the stationary, lower portion of a 60,000-lb Baldwin Tensile Tester by the 1-inch threaded hole in -3. Coupons were held with standard serrated jaws in the upper, movable portion of the tester. Test setup is shown in Figure 3-2. Pressure ranged between 7,000 psig and 4,000 psi. At 4,000, 4,500, and 4,700 psig coupons moved in fixture; 5,000 psig was the lowest pressure which contained the coupons. A 15 percent elongation in a 1-inch gage length was achieved at coupon failure. Two coupons were elongated 9 and 10 percent respectively without proceeding to failure, with a tensile load of 13,800 lb.

Coupons before and after test are shown in Figure 3-3.

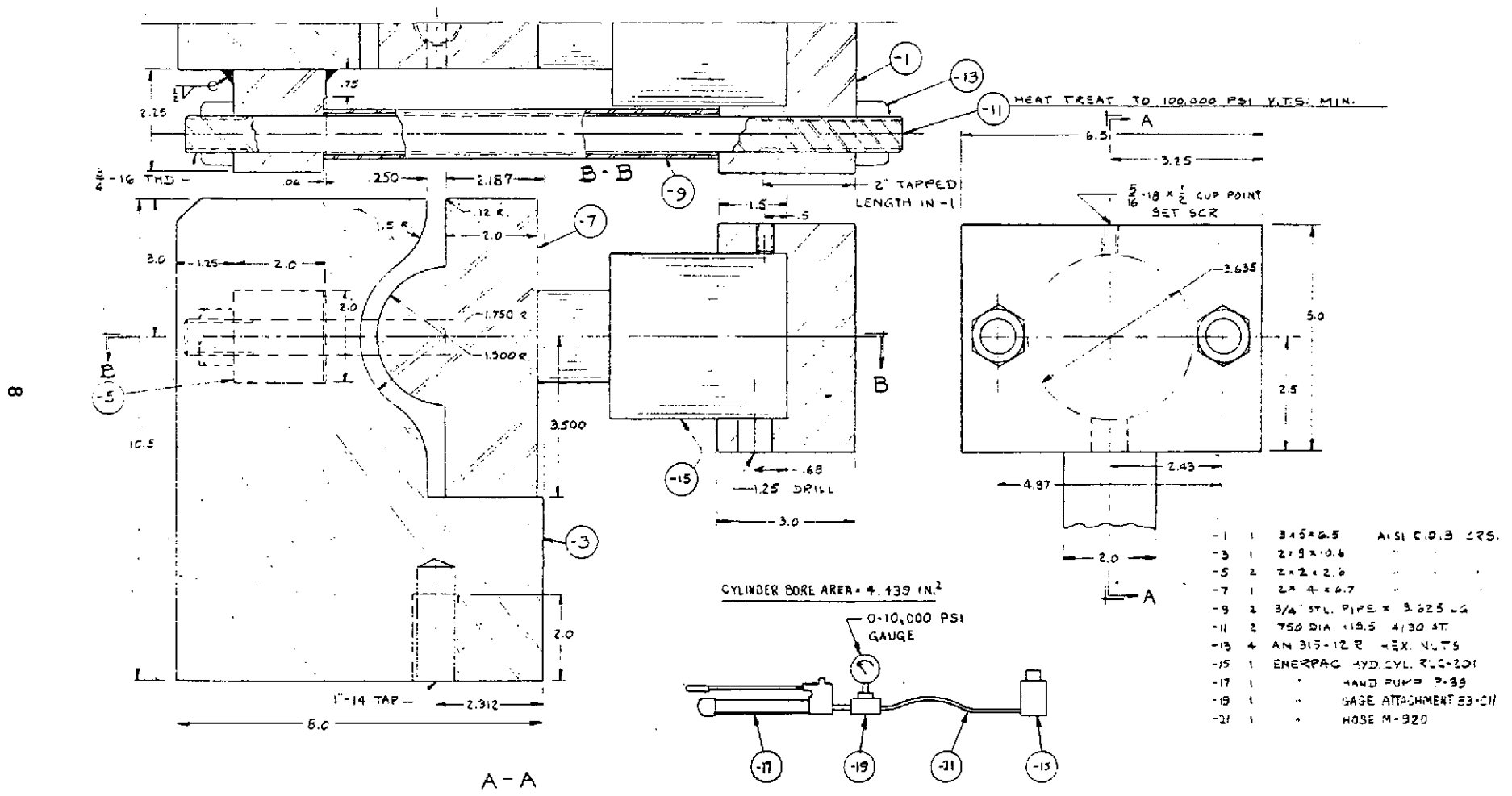

Figure 3-1. Test Fixture for Press Tonnage Determination



Figure 3-2. View Showing Test Fixture in Tensile Tester

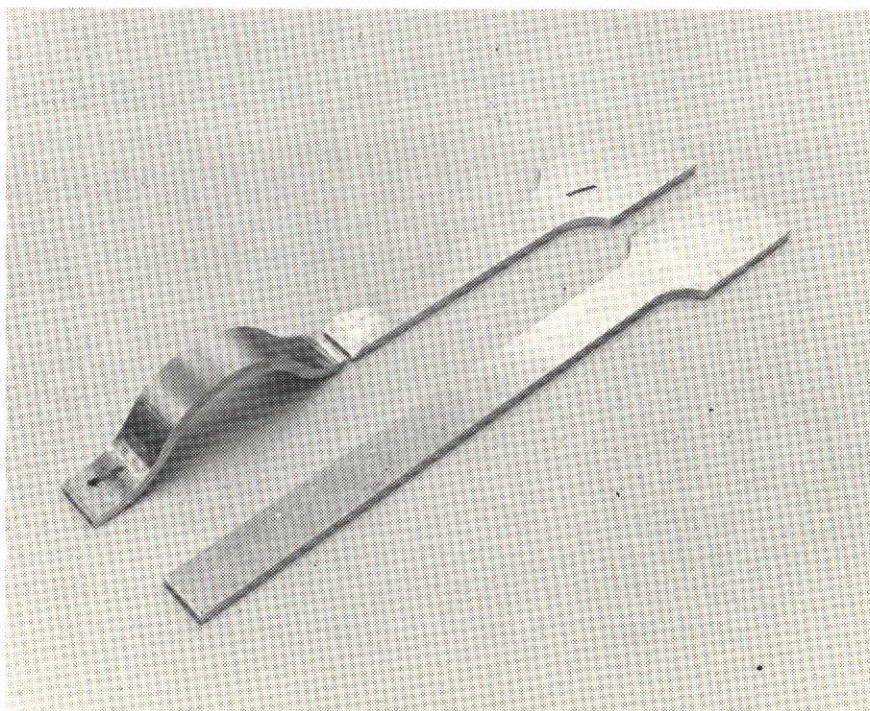

Figure 3-3. View Showing Test Coupons Before and After Test

3.4 TEST RESULTS

The 5,000-psi gage pressure is equivalent to 11.1 tons for restraining 0.250-inch-thick, 1-inch wide 2219-T37 aluminum past the yield point. Extrapolating the 0.250-inch dimension to 0.187 and 0.390-inch which are the material thicknesses for the LH₂ and LO₂ gores respectively, we get forces of 8.3 tons per inch for LH₂ gores and 17.32 tons for LO₂ gores.

These loads are used to estimate the total tonnage requirements for the draw die and pressure in Section 4.

Section 4 DRAW FORMING DIE

4.1 DIE DESIGN

The preliminary die design was made for a 12- and 9-gore configuration as shown on Figure 4-1. This die is suitable for a single acting press such as the 5,000-ton Kaiser press shown in Figure 4-2. The die consists of a cast steel punch on a fabricated steel riser, surrounded by a cast steel lower holddown ring. The ring rests on 40 single-acting hydraulic cylinders which are on a common manifold. The manifold (not shown) is connected to an adjustable pressure relief valve which is connected to an accumulator. The accumulator (not shown) is low pressure (100 psi) with a volume sufficient to receive all the oil from the hydraulic cylinders on the down stroke of the press. The pressurant above the hydraulic oil is shop air. The hydraulic cylinders and punch riser are mounted on a common bolster plate.

The upper part of the die consists of a fabricated steel pressure ring mounted on a fabricated steel bolster. The bolster is required because the shut height of the press is insufficient to close the die. The die can accept a blank in the flat condition without preforming.

Draw beads, similar to those shown on test fixture, Figure 3-1, are located on sides and ends of the die. The beads on the sides lock the material and prevent it from sliding, while the beads on the ends are relieved and lubricated to allow material to slide inward, but to restrain it enough to prevent wrinkle formation. The beads do not extend the entire length of the die rings to permit movement of material in the corners.

4.2 DIE MATERIAL

For the cast portions of the die, the material selected is steel per ASTM A216 Grade WCC, and for the fabricated sections the material selected is steel per ASTM A36.

FOLDOUT FRAME

CR44

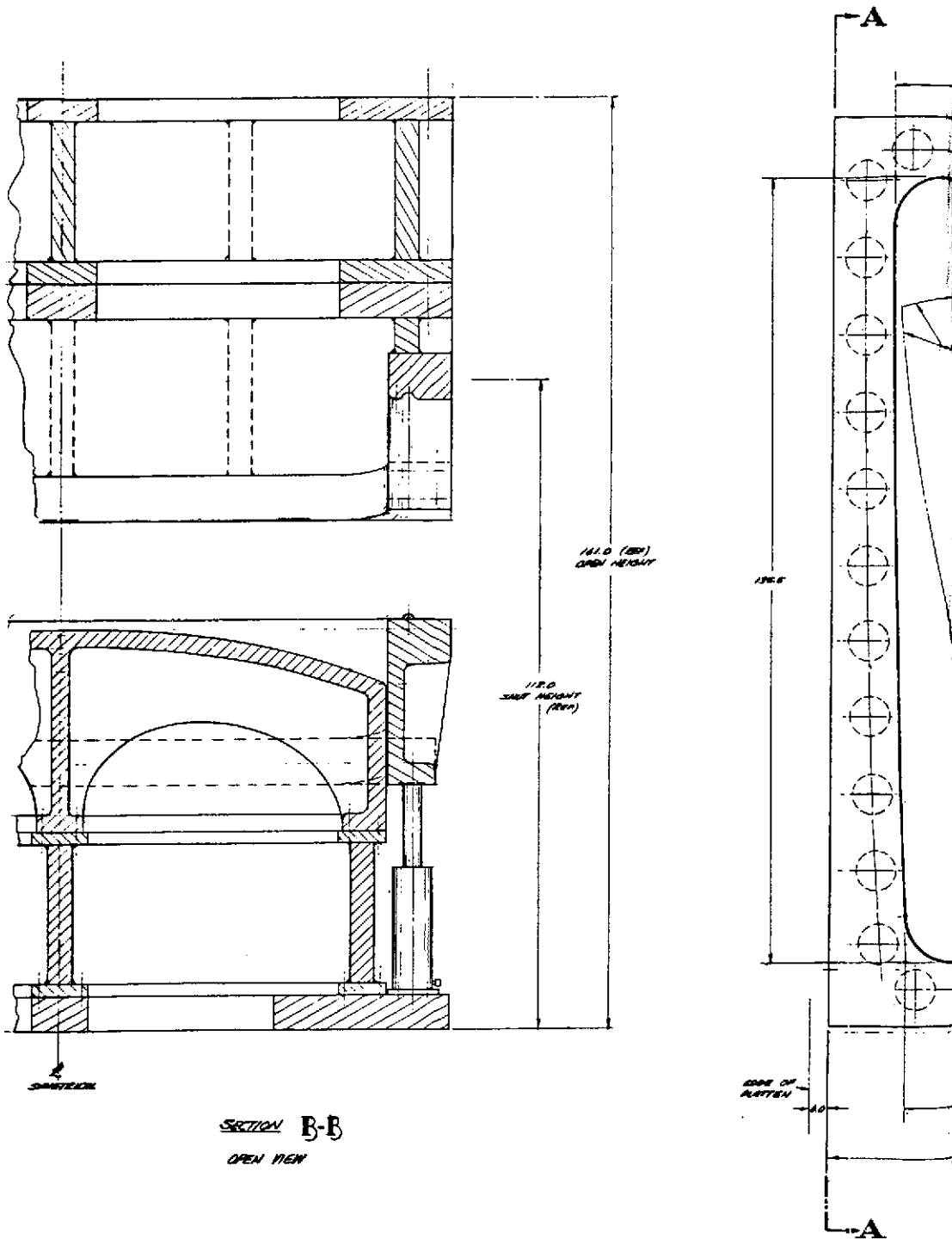

Figure 4-1. Preliminary Die Design for 12- and 9-Gore Configuration

SPEED @:

FREE FALL - 114 IN/MIN

DOWN 950T - 80"

2850T - 27"

4700T - 4"

RETURN 440T - 114"

TONNAGE @

AUX CYLS. 3000 PSI - 950T

FULL 3000 PSI - 2850T

" 5000 PSI - 4700T

RETURN 2000 PSI - 440T

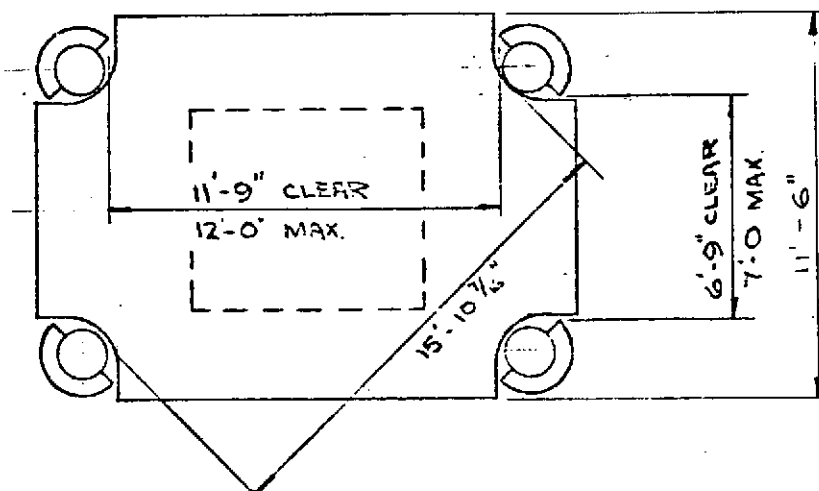
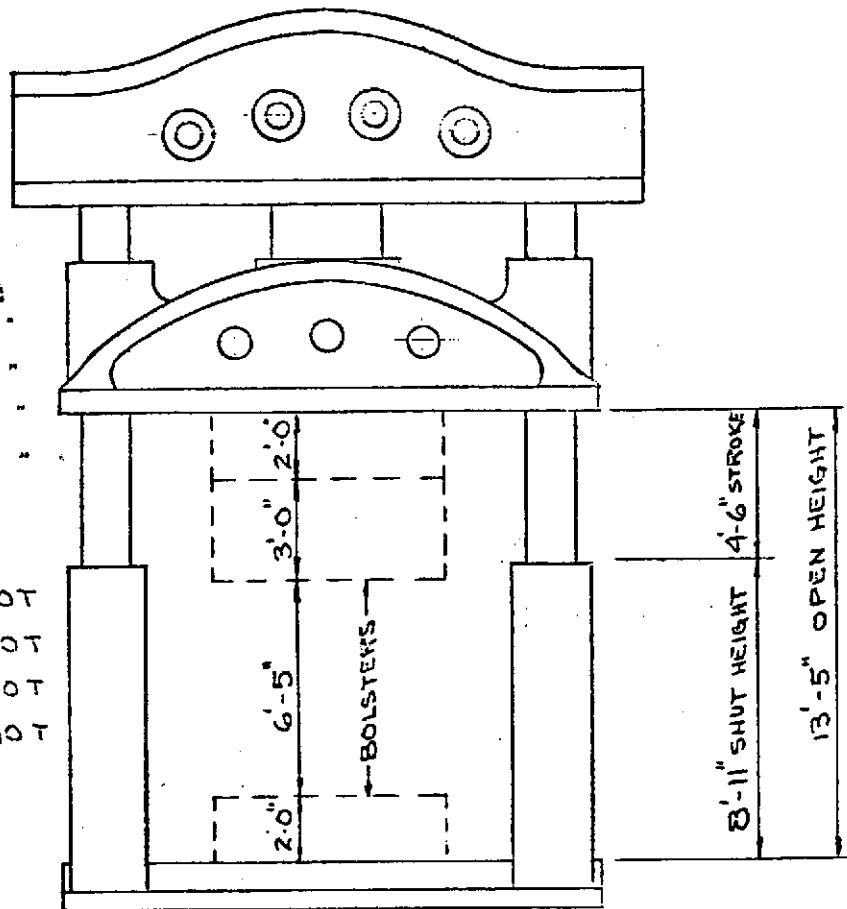

Figure 4-2. Hydraulic Press, 5,000 Ton

4.3 DIE ADDITIONS FOR LO₂ GORES

The die as shown on Figure 4-1 will form LH₂ gores. For LO₂ gore forming, an alternate lower holddown ring is used, because the draw beads for the LH₂ gore thickness will not properly grip the LO₂ gore blanks. Since this ring is floating, the changeover from one ring to the other is relatively fast, approximately 2 hours.

4.4 ALTERNATE PRESS

A triple-action Birdsborough hydraulic press was considered. The daylight (open height) of the Birdsborough press would require some changes in the die, such as elimination of the upper bolster, and reducing of the height of the upper draw ring. These savings would not offset the added costs per gore which would include preforming of the blanks by rolling, and preforming of the ends by press braking.

The multiple actions of the Birdsborough press cannot be used to advantage, because the holddown tonnage required for forming LO₂ gores is greater than the available cushion pressure (2,000 tons), or blank holder pressure (3,000 tons). It would therefore be necessary to use the press in a single-action mode.

4.5 PRESS TONNAGE

Table 4-1 is a pressure profile summary for forming a nine-gore configuration for LH₂ and LO₂ gores on a single acting press, and shows that 2,116 tons are required for forming LH₂ gores and 4,672 tons for forming LO₂ gores.

4.6 GORES THAT GO WITH A 180-INCH DIAMETER CAP

This study and the cost per gore study that follows deals with LH₂ and LO₂ gores that go with a 200-inch-diameter cap per MMC Drawing 82600202000. The gores that go with 140-inch cap were excluded from this study because of excessive overhand of die in the press. However, LH₂ and LO₂ gores that go with a 180-inch cap would have an acceptable press overhang, and would be feasible to manufacture in the same manner as described herein.

Table 4-1

LH₂ GORES 0.187-INCH THICK 2219-T-37 ALUMINUM

Total side bead length 232 in. x 8.3 tons/in.	=	1,925 tons
Total end bead length 182 in. x 1.6 tons/in.	=	291 tons
Forming pressure	=	450 tons
		Subtotal:
		2,666 tons
Less weight of ram and die:		550 tons
		Total:
		2,116 tons

LO₂ Gores 0.390 in. thick 2219-T-37 Aluminum

Total side bead length 232 in. x 17.32 tons/in.	=	4,018 tons
Total end bead length 182 in. x 1.2 tons/in.	=	309 tons
Forming pressure	=	900 tons
		Subtotal:
		5,227 tons
Less weight of ram and die:		550 tons
		Total:
		4,672 tons

The available press tonnage for forming LO₂ gores that go with the 180-inch cap may be marginal if plain draw beads as described before are used. The friction between side draw beads and aluminum plate can be increased by plasma-arc or flame spraying beads with a coarse-grained, tungsten carbide bonded-nickel coating, thus reducing additional press tonnage requirements. A similar application is described in NASA Tech Brief B73-10234.

The overall effect on tooling costs by increasing gore length by 10 inches, is approximately 4 percent. Draw forming time is not affected by the added gore length.

Section 5 MANUFACTURING

5.1 MANUFACTURING PLAN

The gore fabrication production flow chart is shown in Figure 5-1. The chart starts with the receipt of material precut from the mill, followed by inspection and transportation to the press. Sheet handling is accomplished by means of vacuum lift hoist and transport dollies.

5.2 FORMING

Sheets are loaded in press by means of a special handling fixture equipped with vacuum lifts. Sheets are drawn in press and special indexing (tooling) marks are punched on ends of drawn parts. Gores are removed from press with the handling fixture, visually inspected and loaded on handling dollies which transport them in dome sets.

5.3 TRIMMING

Formed gores are loaded on trim fixture with a vacuum lift, positioned to indexing marks, trimmed, allowing 1/4 inch excess for final trim on weld fixture, and tooling holes drilled through indexing marks on tabs. Gores are inspected and unloaded with a vacuum lift onto dollies and moved to cleaning.

5.4 CLEANING

Trimmed gores are alkaline cleaned and water rinsed and transported on dollies to age hardening.

5.5 HEAT TREATING

Cleaned gores are loaded on heat treat fixture by means of vacuum lifts and clamped in place. Fixture is moved into oven and gores are precipitation age hardened to T-87 condition. After removal from oven gores are inspected, loaded on dollies, and moved to chem milling.

PRECEDING PAGE BLANK NOT FILMED

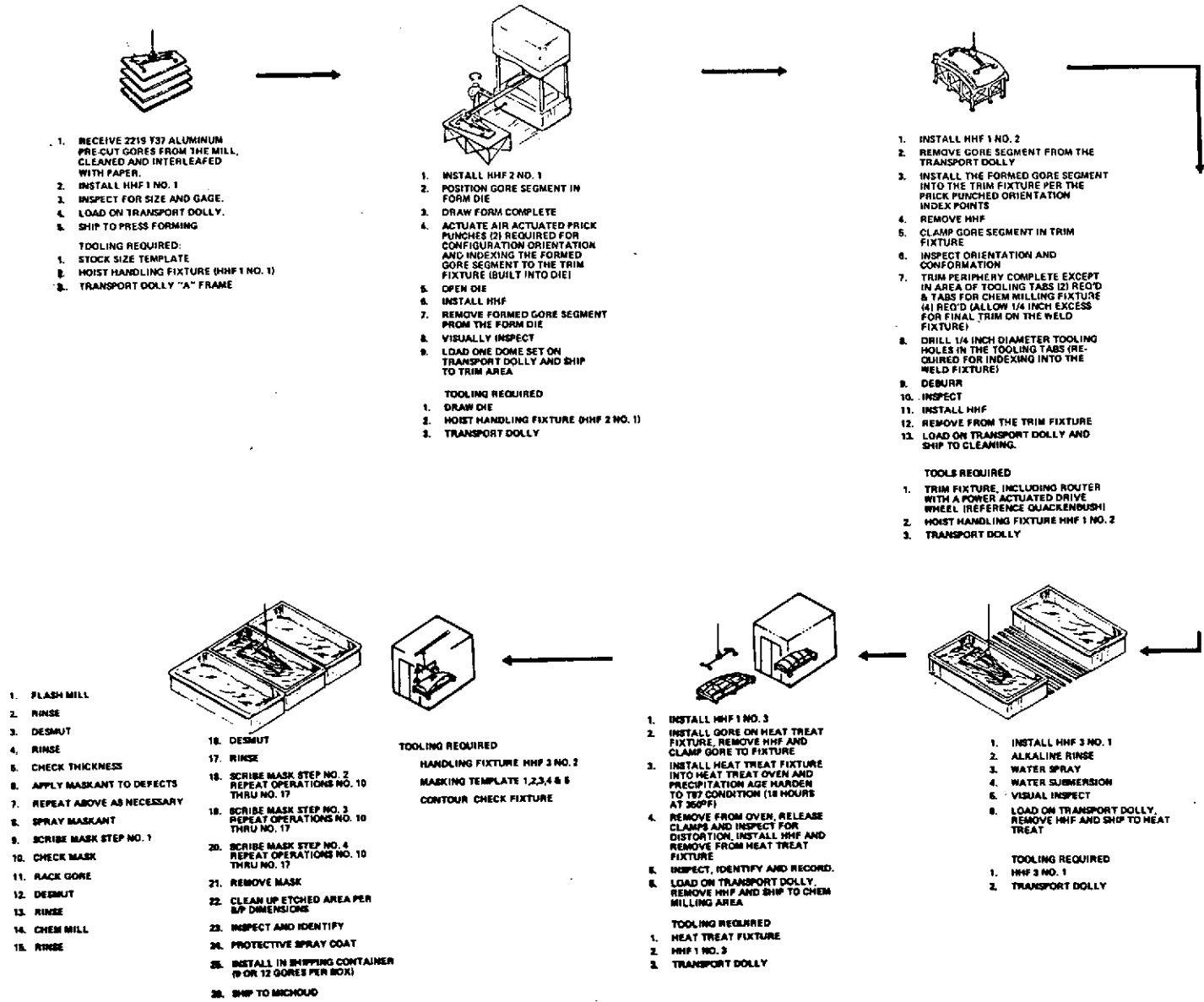

Figure 5-1. Gore Fabrication Production Flow Chart

5.6 CHEM MILLING

The production flow chart describes a chem milling procedure typically used at MDAC. This procedure consists of operations such as flash milling, rinsing, masking, etc. If the chem milling operations are subcontracted, some variations in the chem milling procedures may take place.

5.7 SHIPPING

Gores are loaded in special shipping containers in dome sets. Protection is provided in the containers to prevent shipping and handling damage. Gores are then shipped to Michoud for final trimming and welding.

Section 6 TOOLING

The various tooling concepts used in the costing section of this study are shown in the following figures. Figure 6-1 shows a vacuum lift fixture attached to a hoist. Figure 6-2 shows a vacuum lift fixture attached to a hoist on a swivel gantry. Figure 6-3 shows a hoist handling fixture which picks up gores at tabs. Figure 6-4 shows a contour check fixture which is a typical aircraft type. Figure 6-5 shows a trim fixture for use with routers. Figure 6-6 shows a heat treat fixture which holds part in proper position during precipitation age hardening. Figure 6-7 shows shipping containers suitable for transporting dome sets of 9 or 12 gores. The containers are reusable, with hoisting provisions.

After arrival at Michoud Assembly Facility, the overbox of the shipping container is removed in receiving and the skidded base hoisted and moved by crane to the next production area, where individual gores can be removed by vacuum lifts.

PRECEDING PAGE BLANK NOT FILMED

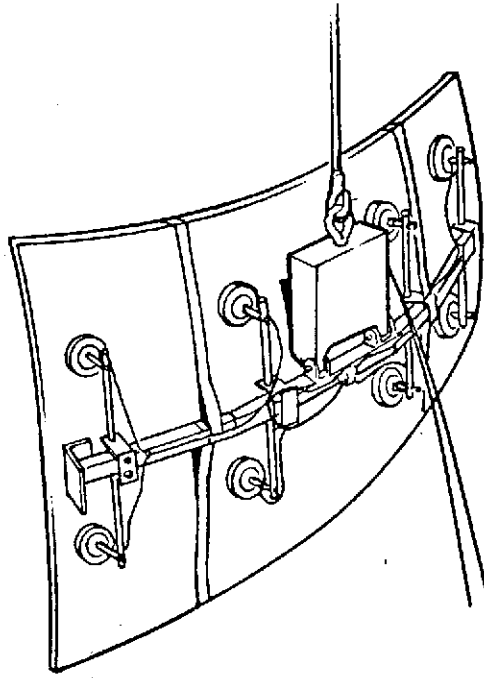

Figure 6-1. Hoist Handling Fixture HFF1 No. 1

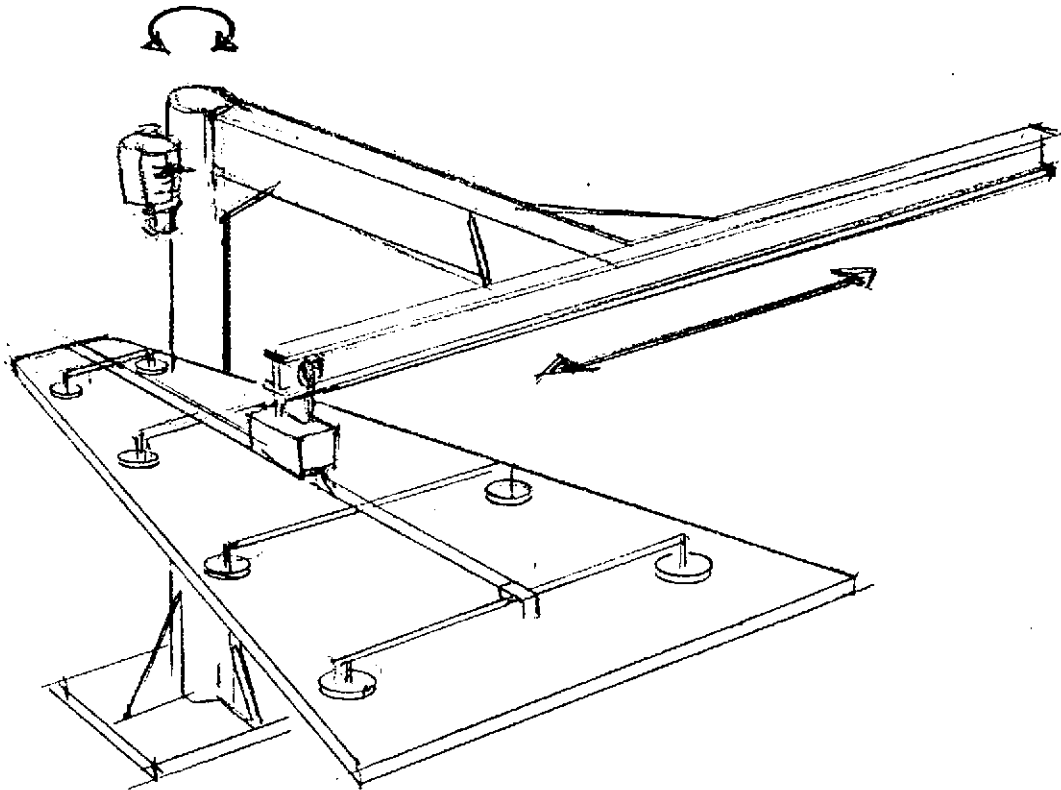

Figure 6-2. Hoist Handling Fixture HFF2 No. 1

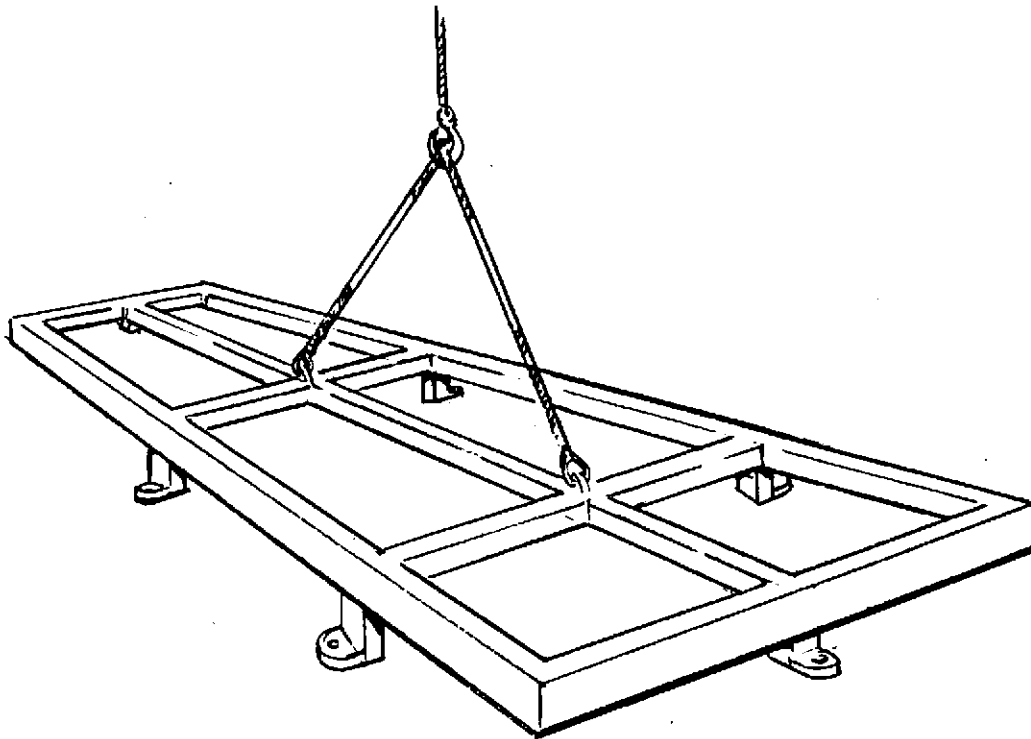

Figure 6-3. Hoist Handling Fixture HHF3 No. 1

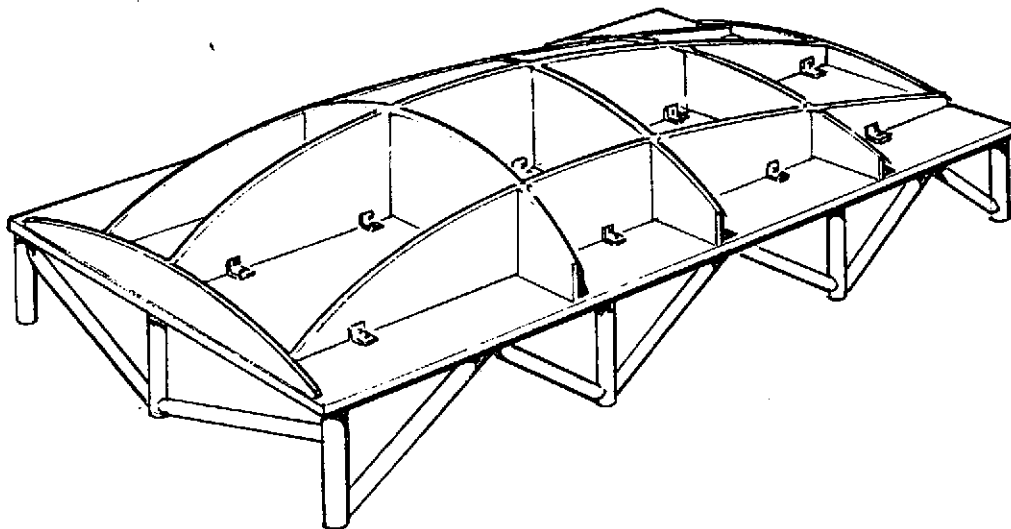

Figure 6-4. Contour Check Fixture

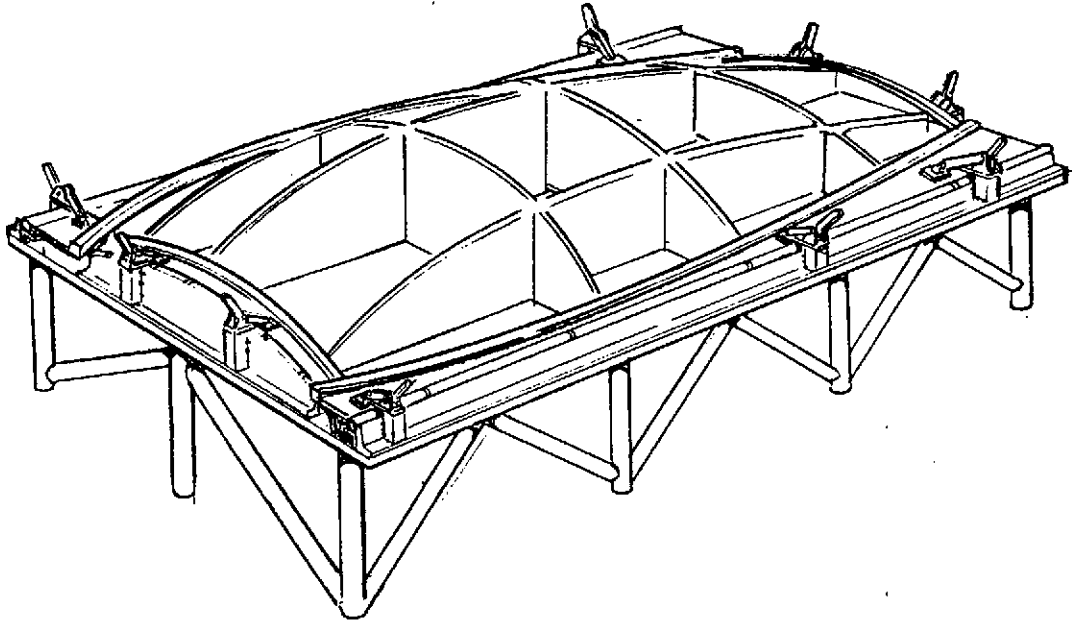

Figure 6-5. Trim Fixture

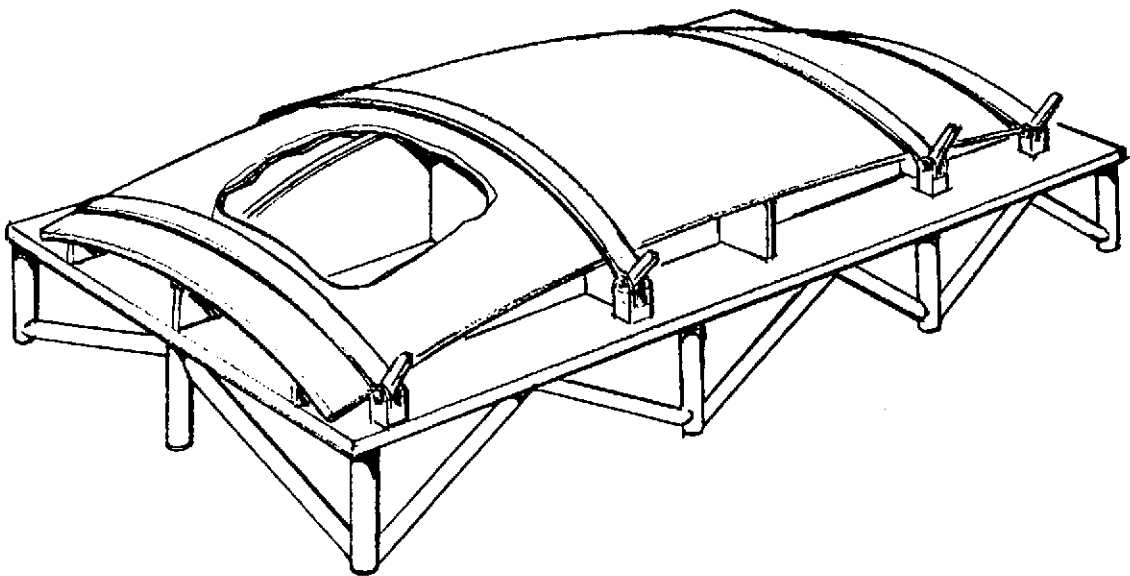

Figure 6-6. Heat Treat Fixture

CONFIS.	DIM. A	DIM. B	DIM. C
9 GORE	119	120	37
12 GORE	119	89	33

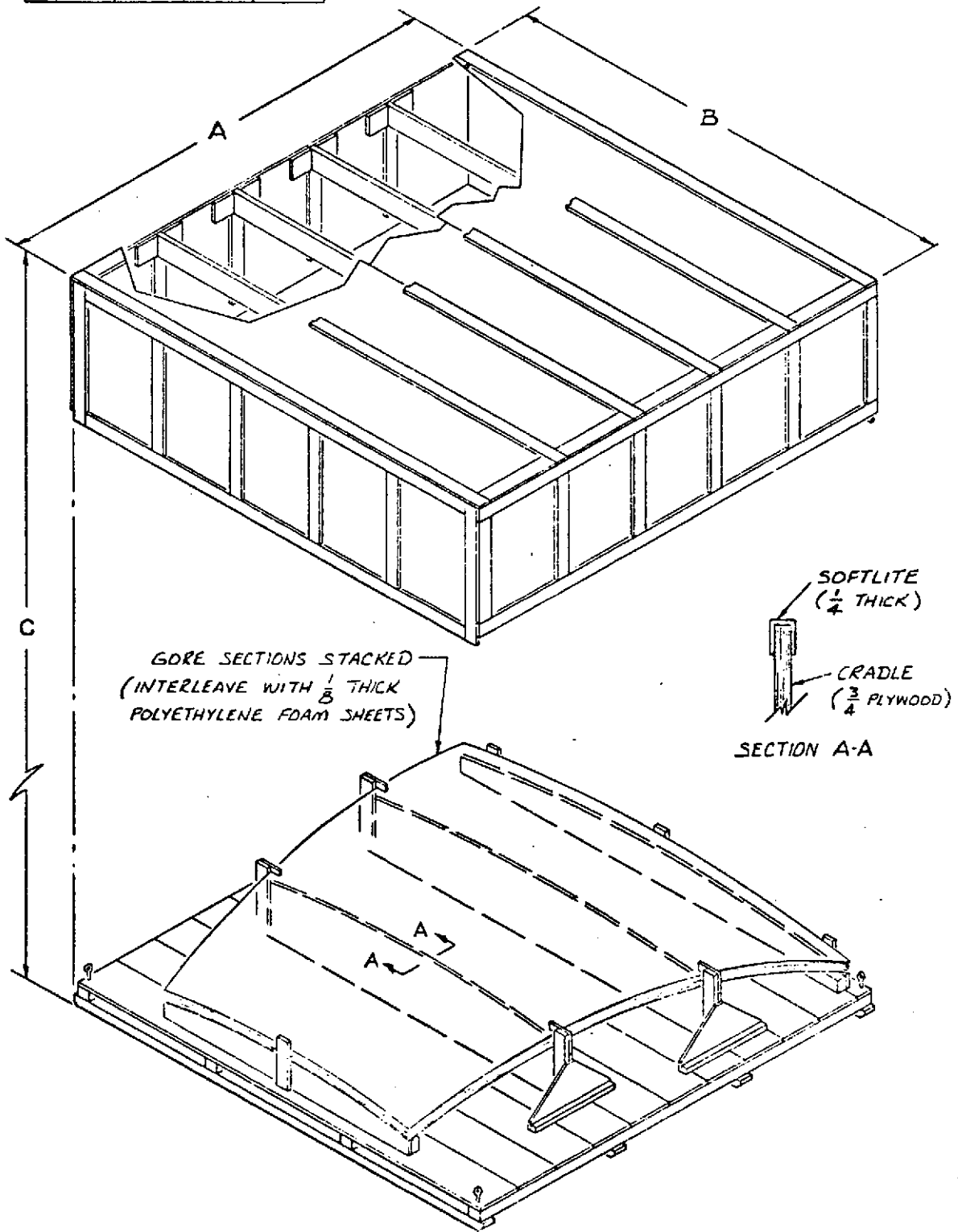

Figure 6-7. Shipping Container