

2 mif

JPL SP43-8

AUTOMATED FIREARMS IDENTIFICATION SYSTEM (AFIDS): PHASE I

Jet Propulsion Laboratory
California Institute of Technology
Pasadena, California 91103

| | | |
|--------------------------------|---------------------------|-------------|
| (NASA-CR-139371) | AUTOMATED FIREARMS | N74-30381 |
| IDENTIFICATION SYSTEM (AFIDS), | PHASE 1 | |
| (Jet Propulsion Lab.) | 28 p HC \$4.50 | |
| | 34 | |
| | CSCL 05A | Unclas |
| | | G3/34 44993 |

Prepared for
Applications Technology Office
NATIONAL AERONAUTICS AND SPACE ADMINISTRATION

AUTOMATED FIREARMS IDENTIFICATION SYSTEM (AFIDS): PHASE I

R. J. Blackwell
E. P. Framan

Jet Propulsion Laboratory
California Institute of Technology
Pasadena, California 91103

July 1, 1974

Prepared for
Applications Technology Office
NATIONAL AERONAUTICS AND SPACE ADMINISTRATION

PREFACE

This work was sponsored by the Applications Technology Office of the National Aeronautics and Space Administration through Contract NAS 7-100.

PRECEDING PAGE BLANK NOT FILMED

CONTENTS

| | | |
|------|---|----|
| I. | INTRODUCTION | 1 |
| II. | OBJECTIVES | 2 |
| | A. Overall Objective | 2 |
| | B. Phase I Objectives | 2 |
| III. | REPRODUCIBILITY | 3 |
| | A. Literature Search and Discussions With Authorities on Reproducibility | 3 |
| | 1. Criteria of Identify | 3 |
| | 2. Discussion of Problem of Reproducibility of Striations on Bullets From Rifled Firearms | 6 |
| | B. Test Firings of Representative Firearms | 6 |
| | C. Simulation Study to Determine Statistical Parameters | 6 |
| | 1. Approach | 8 |
| | 2. Conclusions from Simulation Study | 9 |
| IV. | MEASUREMENT OF DEPTH OF GROOVE | 10 |
| | A. General | 10 |
| | B. Surface Profiling | 10 |
| V. | DEVELOPMENT OF GENERALIZED CONCEPTUAL SOFTWARE FOR AFIDS | 12 |
| | A. Test Data Accumulation | 12 |
| | B. Goals of Image Processing of Bullet Data | 12 |
| VI. | CONCLUSIONS AND RECOMMENDATIONS | 20 |
| | A. Conclusions | 20 |
| | B. Recommendations | 20 |
| | REFERENCES | 20 |
| | APPENDIX. AUTOMATED FIREARMS IDENTIFICATION SYSTEM (AFIDS): PHASE 0 | 21 |
| | TABLE | |
| | A-1. Rejected measuring techniques | 24 |
| | FIGURES | |
| | 1. Example illustrating concept of consecutiveness of lines | 4 |
| | 2. Probability estimates for consecutive matching lines (series) | 5 |
| | 3. Idealized striations positioned by random numbers | 7 |

| | | |
|------|--|----|
| 4. | Computer-produced idealized striations | 7 |
| 5. | Comparison of sequences | 8 |
| 6. | Typical surface profiling recording around a bullet | 10 |
| 7. | Lead bullet, 100 X | 11 |
| 8. | Three-fourths jacket bullet, 475 X | 11 |
| 9. | Lubaloy jacketed bullet, 500 X | 11 |
| 10. | Full copper jacketed bullet, 525 X | 11 |
| 11. | Schematic diagram of image processing system for bullet data | 14 |
| 12. | Scanned photograph of an "unwrapped" bullet | 15 |
| 13. | "Unwrapped" bullet image after geometric correction for off-center rotation and elimination of excess scan | 15 |
| 14. | Geometric transformation of Fig. 13, to permit Fourier transformation | 16 |
| 15. | Fourier transform of geometrically rectified bullet image of Fig. 14 | 16 |
| 16. | Idealization (bottom) of bullet image — amplitude threshold 5 | 18 |
| 17. | Idealization (bottom) of bullet image — amplitude threshold 8 | 19 |
| A-1. | Automated light microscope system | 25 |
| A-2. | Samples of profile data obtained by stylus methods | 25 |
| A-3. | Example of image-type bullet data | 26 |

ABSTRACT

Items critical to the future development of an automated firearms identification system (AFIDS) have been examined, with the following specific results:

- 1) Types of objective data, that can be utilized to help establish a more factual basis for determining identity and nonidentity between pairs of fired bullets, have been identified.
- 2) A simulation study has indicated that randomly produced lines, similar in nature to the individual striations on a fired bullet, can be modeled and that random sequences, when compared to each other, have predictable relationships.
- 3) A schematic diagram of the general concept for AFIDS has been developed and individual elements of this system have been briefly tested for feasibility.

Future implementation of such a proposed system will depend on such factors as speed, utility, projected total cost and user requirements for growth. The success of the proposed system, when operational, would depend heavily on existing firearms examiners.

SECTION I

INTRODUCTION

Calvin Goddard, the father of modern firearms identification, described the process of comparing fired bullets as both an art and a science. The growth of this art/science has been primarily due to the adaptation of the comparison microscope to firearms identification.

The identification of firearms by this method is based upon the principle that the bullet, in passing through the barrel, is engraved by the irregularities of the barrel produced during manufacture and subsequently modified by wear, corrosion, etc. These engravings, i.e., the "class" characteristics and striations (which are "individual" characteristics), are then a negative, composite image of the irregularities of the barrel. These irregularities will vary from one bullet to the next in a way dependent on many variables; e.g., hardness and dimensions of bullet, the dimensions and state of wear of the barrel, the amount of powder, foreign material in the barrel, etc. The examiner observes the similarities and dissimilarities between the class characteristics and striations of the bullets being compared. From the knowledge he has gained through observing known specimens, he renders an opinion as to whether these similarities or dissimilarities are sufficient to establish identification, nonidentification, or no positive conclusion.

The striations imparted to different bullets by the same gun barrel are rarely identical, even over limited areas of the bullets, and are constantly and permanently changing as each successive bullet is fired. A perfect match around the entire circumference of a bullet is only a theoretical possibility and probably a practical impossibility when one considers how the striations on a bullet are formed (Ref. 1). It may be logically asked, what then constitutes an identity or nonidentity of two fired bullets? A search of the literature up to the present has revealed no verifiable general laws that can be used in establishing identity or nonidentity. One can only conclude that the determination of identity or nonidentity of fired bullets is, in

reality, nothing more than the professional opinion of each individual firearms examiner — competent or incompetent.

In 1956, Alfred H. Biasotti wrote a thesis entitled "Bullet Comparison, A Study of Fired Bullets, Statistically Analyzed" (Ref. 2) for the Graduate School of Criminology, University of California at Berkeley, California. Biasotti's thesis attempted to establish some fundamental objective basis for solving the problem of identity and nonidentity of fired bullets. Biasotti's work is the only effort uncovered to date which seriously attempts to establish firearms identification on a basis of fact and not opinion. He sought to accomplish this by conducting a statistical study of the relative frequency of occurrence of the elements which actually form the basis of the identity or nonidentity (viz., class characteristics and striations). He attempted to establish some verifiable general laws based upon statistical fact which other examiners could use as a guide and reference in reaching and confirming their conclusions of identity or nonidentity.

Biasotti was able to conclude from his study that such parameters as average line count, numbers of matching lines, percent matching lines, etc. were an unreliable means of establishing identity. This unreliability was due to the high chance occurrence (about 20%) of individual match lines for bullets from different guns and the low average percent match for bullets from the same gun (all without regard to consecutiveness).

It was demonstrated by Biasotti that the criterion of consecutive matching lines (3 for lead bullets and 4 for metal-cased bullets) appears to be an effective and reliable means of establishing identity. That is, if bullets coming from different guns exhibit 3 or less consecutive matching lines there is a high statistical probability that the bullets did not come from the same gun.

SECTION II OBJECTIVES

A. Overall Objective

The overall objective of the Automated Firearms Identification System (AFIDS) Task is to demonstrate a system, based on existing technology, that has the capability of automated examination, characterization, and identification of bullets for the purpose of firearms identification. The feasibility of this system will be demonstrated in an operational environment. The costs and operating capabilities will be within the requirements and constraints of the expected user.

B. Phase I Objectives

The general objectives of Phase I of this task were to examine, test, and evaluate individual elements that are critical to the overall task objective of AFIDS and examine the overall feasibility of the system. Programmatic restrictions prevented accomplishing this and so a limited Phase I was undertaken. Hardware development was thus not included in the scope of work. Other elements of critical technology could still, however, be studied and developed.

Accordingly, the specific objectives of the limited Phase I were as follows:

- 1) Conduct a test program and an in-depth investigation into the reproducibility of class characteristics and striations of bullets fired from the same firearm. Determine how many matching striations must be present for the identification to be considered statistically significant.
- 2) Examine in detail the utility and value of depth-of-groove data as a measured class characteristic. In addition, determine what effect the surface deformation caused by the stylus used in measuring depth of groove has on the validity of the identification process.
- 3) Develop schematically a software plan which will provide for the use of a computer in feature extraction and pattern analysis of the bullet image data.

As a result of the limitations, the resolution of some of the elements of critical technology identified in the task plan have not been examined to the extent deemed necessary.

SECTION III REPRODUCIBILITY

The first specific objective, shown as item (1) in Subsection II-B, was to investigate the problem of reproducibility; i.e., to determine the extent to which bullets fired from the same gun are similarly marked. Of primary concern was the determination of the limits on the number of matching striations which will have statistical significance for identification. The effort to achieve the first specific objective was divided into three subtasks: 1) literature search and discussions with authorities; 2) test firings of representative firearms and examination of the bullets; and 3) a simulation study to determine some of the statistical parameters of randomly produced lines or striations. The results of these subtasks are discussed below.

A. Literature Search and Discussions With Authorities on Reproducibility

1. Criteria of Identity

From the number of texts devoted exclusively to the subject of firearms and toolmark identification, it might appear that this specialized area of physical comparison is a highly developed science, with well-defined criteria for evaluating evidence and establishing identity. On the contrary, a review of the literature reveals a very superficial treatment of this basic problem. The literature in this field is devoted almost entirely to topics ancillary to the main objective of establishing identity. Only three references can be cited which are concerned specifically with developing objective criteria for establishing identity. First, in 1931, Lucas (Ref. 3) recorded the frequency of occurrence of striations and attempted to describe the general character of the striations on some 200 fired bullets; however, the scope and general nature of the presentation makes this reference of little more than historical value. Next, in 1942, Burd and Kirk (Ref. 4) made a statistical study of the frequency of matching striations in toolmarks; the results were presented in terms of percent match. Lastly, Biasotti (Ref. 2), in 1959, reported on a statistical study of the striations of fired bullets in which the results were presented in terms of consecutive matching striations. In general, the texts on firearm identification take the position that each practitioner must develop his own intuitive criteria for identity from practical experience.

The major effort under this subtask was to study the work of Biasotti (Ref. 2) and interpret his findings. As discussed in other sections of this report, Biasotti's investigations are chiefly concerned with a statistical analysis of striations, a key element in firearms identification.

The primary and most important result of Biasotti's findings is that the criterion of "consecutive matching lines" (see below) appears to be an effective and reliable means of statistically analyzing the true elements of identity.

Biasotti used a direct approach: he observed and quantitatively recorded the relative frequency of occurrence of matching and non-matching lines in order to find some factual data which could be used in answering the basic question of what constitutes identity of two bullets fired by the same gun and nonidentity of two bullets fired from different guns.

Definition of the Criteria of Consecutive Matching Lines

When striations are grouped or related by the criteria of consecutiveness, which is the compounding of a number of striations, the chance occurrence of even a very small number of consecutive matching lines (e.g., more than 3 or 4) is for all practical purposes impossible except as a result of a common agent (*viz.*, same gun).

Figure 1 illustrates very simply the concept of consecutiveness of lines. The validity of this concept of consecutiveness is substantiated by the probability estimates calculated from the relative frequency of occurrence of consecutive matching lines both for bullets fired from the same gun and for bullets fired from different guns. These estimates are reproduced graphically in Fig. 2. Figure 2a relates the findings of lead bullets in used guns showing a net decrease in the total number of detected lines. Figure 2b illustrates some of the findings of Biasotti's research. The graph shows that there is a 10% probability that two lead bullets fired from different guns can have as many as 3 consecutive matching lines. The graph also indicates that two lead bullets fired from the same gun can have as many as 10 or 12 consecutive matching lines. The interesting and important point is that the base line of separability for identification of lead bullets is 3 consecutive matching lines. Figure 2c is a graph of the same findings as related to metal-jacketed bullets. Figure 2d shows that new guns with metal-cased bullets yield greater numbers of lines (consecutive) than do lead bullets fired from new guns or used guns, using only the lines detected on the lands-portion of the bullet. Figure 2e shows the same analysis as applied to the grooves portion of the bullet.

The graphs indicate that three consecutive lines for lead bullets and four consecutive lines for metal-jacketed bullets

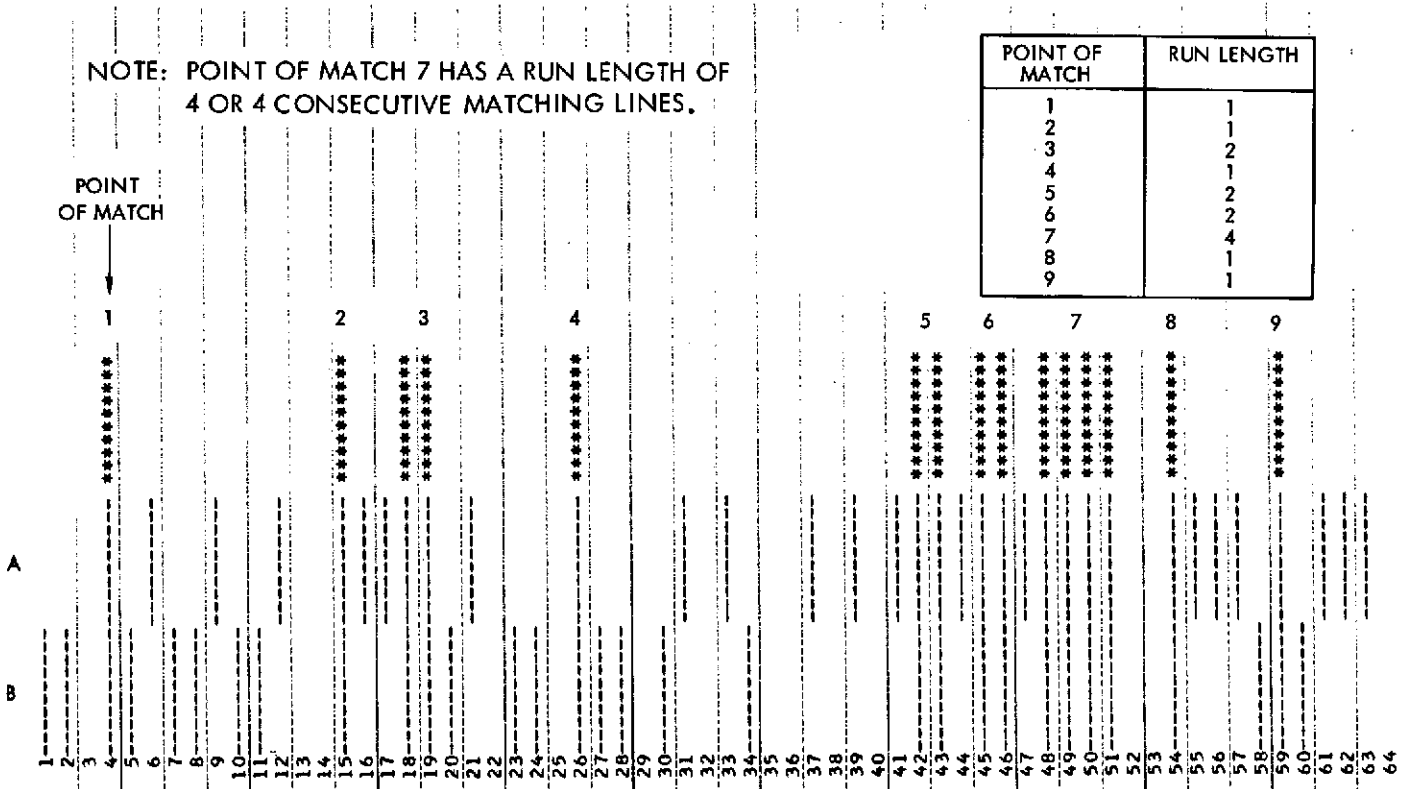
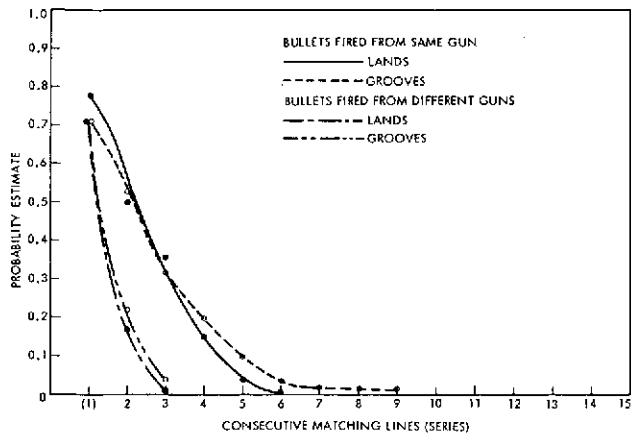
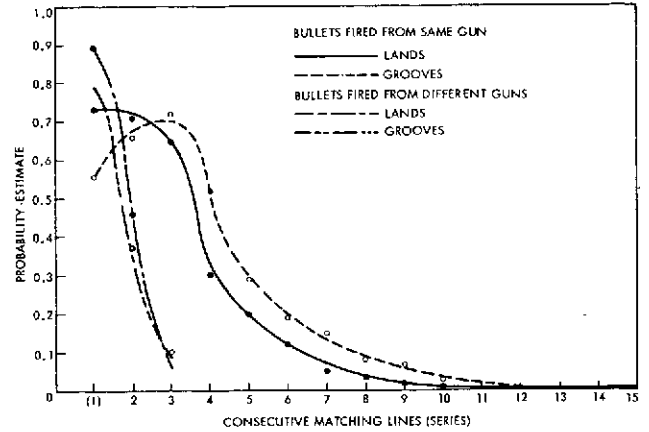

Figure 1. Example illustrating concept of consecutiveness of lines



a. Used guns (lead bullets)



b. New guns (lead bullets)

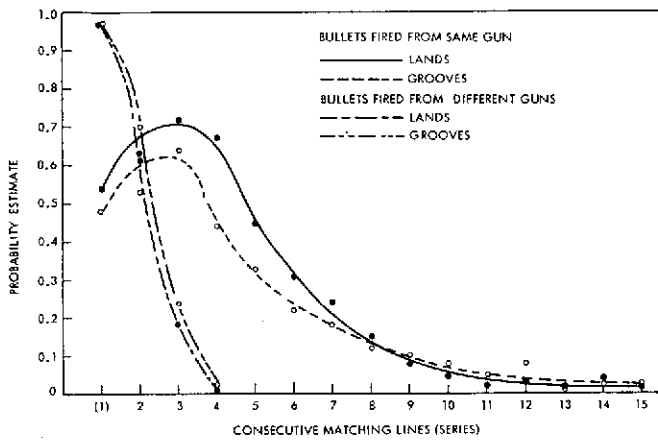

c. New guns (metal-cased bullets)

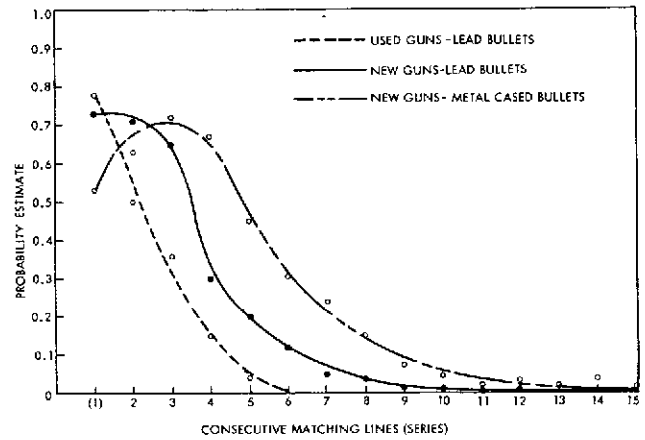

d. Lands-bullets fired from same gun

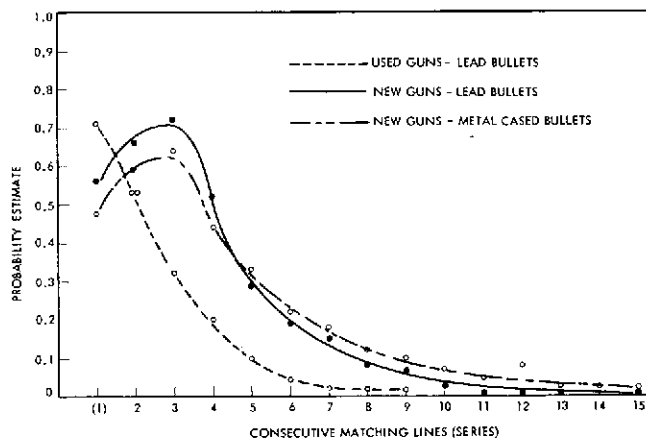

e. Grooves-bullets fired from same gun

Figure 2. Probability estimates for consecutive matching lines (series)

appear to be the baseline for establishing identity/nonidentity for bullets fired from different guns.

Biasotti's gun-bullet sample was small (16 used .38 cal. and 8 new .38 cal. with 6 bullets fired through each); but it is believed that the results of his research may be typical of results achieved from a larger sample.

2. Discussion of Problem of Reproducibility of Striations on Bullets From Rifled Firearms

D. Wolfer of the Los Angeles Police Department (LAPD) Firearms Laboratory, in a discussion on this subject on January 19, 1972, made the following points:

Bullets fired from the same firearm over a period of time may or may not exhibit the same individual characteristics. Since the unique characteristics which identify any individual firearm are contingent upon many factors, the problem of reproducibility becomes complex. For example, a police officer, operating under departmental policies, is required to fire approximately 100 rounds per month to maintain his proficiency. Since the officer's firearm is such an important part of his equipment, he develops pride and interest in maintaining it in superior working condition.

The police officer, because of his frequent use of the firearm, more often than not will completely obliterate many, if not all, of the original identifying imperfections in the bore by his constant attention to cleaning and polishing. According to Wolfer, many officers mount their pistols in a drill press and actually wire-brush the bore to the point that individual features originally in the bore are removed, and new ones created.

At the other end of the reproducibility spectrum are military small arms. These firearms, because of the nature of mass production, frequently retain their identifying characteristics for the life of the firearm. During manufacture, the bores are not carefully polished or lead lapped and the small blemishes that cause striations are retained virtually unchanged. Subsequent perfunctory or even diligent cleaning frequently does not obliterate them.

In between these two extremes are the firearms that most frequently find their way into the firearms identification laboratory. These firearms are frequently police-type firearms such as calibers .32, .38, and .45, but are not, as a rule, maintained as well as the police officer maintains his, nor are they fired with such frequency. This group also contains many of the easily identifiable military weapons. It is because of this unique combination of types of users and types of firearms that firearms identification is able to function. The criminal uses his firearm infrequently and for the most part does not maintain it with such care that he removes identifying features. There are exceptions, such as members of organized

crime and professional gunmen, but firearms from these sources do not make up the bulk or majority of weapons coming into the firearms laboratory.

Burrard, in his book, "The Identification of Firearms and Forensic Ballistics" (Ref. 5), states that, for lead bullets, the finer striations change completely after 50 rounds have been fired in a firearm. For jacketed bullets such a change may take place after as few as 25 rounds. Discussions with Biasotti indicated that Burrard's numbers are in basic agreement with his own experience.

B. Test Firings of Representative Firearms

The original plan for this subtask was to conduct a series of independent test firings to attempt to establish some measure of reproducibility.

It was rather quickly realized that such a program, while well-intentioned and probably meaningful in terms of some figure of merit for reproducibility, could not be carried out. It had been hoped that the LAPD Firearms Laboratory would assist, but the task — which involved firing bullets in .22, .32, .38, and .45 caliber firearms and examining each bullet for multiple unique striations — proved to be too large. However, test firings of lead and jacketed bullets through two .38 caliber Super Colt automatics were conducted and these samples were subsequently used for data input for future software development.

C. Simulation Study To Determine Statistical Parameters

This subtask was to conduct a simulation study of striations to determine some of the statistical parameters of randomly produced lines or striations.

The idea for this study resulted from a paper by Brackett (Ref. 6) who attempted to use idealized striations to develop a theoretical basis for striation analysis.

Brackett was able to show that idealized lines produced by various random and nonrandom methods can be described as having a predictable relationship to each other when compared and analyzed. His approach was, for example, to use a random number table to dictate the positioning of an idealized line. The results of each determination were then plotted serially on cross-section paper and the number and distribution of matched striations then noted.

An example of this approach is shown in Fig. 3. The vertical marks above the horizontal line are positioned by one row of the random number table, and the vertical marks below the horizontal line are positioned by another row from the random number table. If the marks above and below meet, it is considered a match. If not, it is considered a nonmatch.

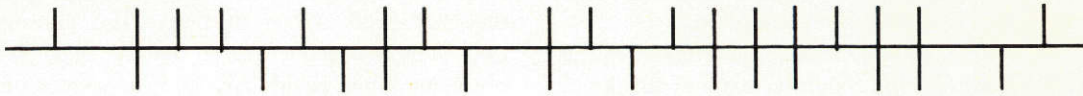

IN THIS EXAMPLE, THE DIGITS FROM THE RANDOM
NUMBER TABLE ARE USED AS FOLLOWS:

- 1 AND 2 = 1 SPACE
- 3 AND 4 = 2 SPACES
- 5 AND 6 = 3 SPACES
- 7 AND 8 = 4 SPACES
- 9 AND 0 = IGNORED

Figure 3. Idealized striations positioned by random numbers

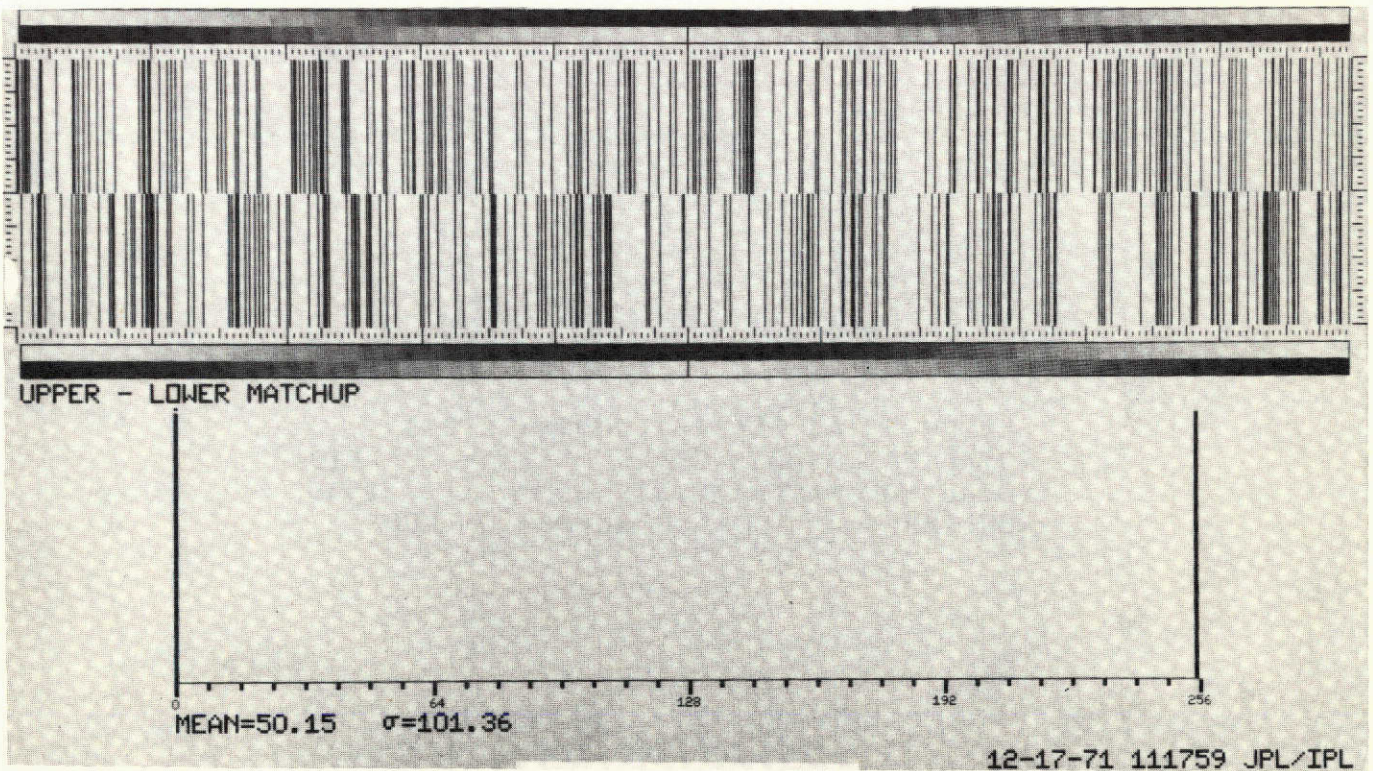

Figure 4. Computer-produced idealized striations

Brackett was able to show that for various probabilities, the randomly produced lines, when compared for consecutiveness and run length, had a predictable relationship.

The purpose of the simulation study undertaken in this subtask was to implement on the computer some of Brackett's methods.

1. Approach

The approach used consisted of generating two vectors or arrays of random numbers representing two sets of vertical

marks as seen in Fig. 3. The two vectors were then compared for match-nonmatch and for run length. Figure 4 illustrates a sequence produced in this way. This photograph represents two simulated sequences so set up that the probability of obtaining a line equals 20% and the chance of not obtaining a line equals 80%.

Another program was created which would compare the sequences so as to determine the statistics of such comparisons. Figure 5 illustrates one such comparison. Sequence (A) and sequence (B) are two randomly produced sequences

| SEQUENCE (A) | | SEQUENCE (B) | |
|---------------|---------|---------------|---------|
| TOTAL STRIAE | = 1025 | TOTAL STRIAE | = 1023 |
| TOTAL SAMPLES | = 2048 | TOTAL SAMPLES | = 2048 |
| PROBABILITY | = 0.500 | PROBABILITY | = 0.500 |
| 1 | 266 | 1 | 275 |
| 2 | 135 | 2 | 117 |
| 3 | 60 | 3 | 70 |
| 4 | 34 | 4 | 26 |
| 5 | 15 | 5 | 18 |
| 6 | 6 | 6 | 7 |
| 7 | 5 | 7 | 3 |
| 8 | 2 | 8 | 2 |
| 9 | 0 | 9 | 1 |
| 10 | 0 | 10 | 0 |
| 11 | 1 | 11 | 2 |
| 12 | 0 | 12 | 0 |
| 13 | 0 | 13 | 0 |
| 14 | 0 | 14 | 0 |
| 15 | 0 | 15 | 0 |
| 16 | 0 | 16 | 0 |
| 17 | 0 | 17 | 0 |
| 18 | 0 | 18 | 0 |
| 19 | 0 | 19 | 0 |
| 20 | 0 | 20 | 0 |

| SEQUENCE (A) AND (B) COMPARISONS | |
|----------------------------------|----------------|
| TOTAL MATCHING STRIAE | = 513 |
| TOTAL NON-MATCHING STRIAE | = 1535 |
| RUN LENGTH | NUMBER OF RUNS |
| 1 | 302 |
| 2 | 63 |
| 3 | 20 |
| 4 | 5 |
| 5 | 1 |
| 6 | 0 |
| 7 | 0 |
| 8 | 0 |
| 9 | 0 |
| 10 | 0 |

Figure 5. Comparison of sequences

with equal probabilities of having lines or no lines. The tabulations under both sequences represent the various run lengths contained by each. For example, sequence (A) has 266 single lines (each line is a mark with a blank space on each side of it). Sequence (A) also has 135 doublets, or two lines consecutively, etc. The total number of striations for each sequence is approximately the same (1025 vs. 1023).

When (A) is compared to (B) the run lengths shown are produced. The parameters produced for the sequences are in very close agreement with those produced manually by Brackett. Brackett found that the distributions for these idealized striations obey the relationship:

$$N/P = S_1 (1 + 2/r + 3/r^2 + 4/r^3 + \dots)$$

where

$$r = S_1/S_2; r^2 = S_2/S_3; \text{ etc}$$

N = total number of striations

P = reciprocal of the probability of match

S_1 = number of runs of length 1; S_2 = number of runs of length 2; etc.

When $r = r^2 = r^3 \dots = P$, the probability of any striation matching is independent of the other striations. When r^2, r^3, \dots are all functions of r , dependent systems are prescribed. When r^2, r^3, \dots are unrelated, the general case exists, including identical and near-identical sets.

2. Conclusions from Simulation Study

It is interesting to note that when there are two different random sequences of similar character (both have a 50% chance of having striations or not having striations) such as seen in Fig. 5, the results closely parallel those of Biasotti's data. Biasotti expected runs of 3 or 4 consecutive matching lines for bullets from different guns. The simulation run indicates a single run of 5 consecutive lines. This difference can be attributed to the fact that the simulation run contains approximately four times the total number of striae than did Biasotti's. As a consequence of this there is a greater probability of matching consecutive lines.

The important fact is that the simulation of bullet comparisons by random number methods is a viable means of understanding the process of identification.

To extend Brackett's and Biasotti's research further, the problem of changing the phase relationship between sequences was undertaken. When two *random* sequences are compared with the phase of one sequence shifted relative to the other, a different set of run length statistics is obtained. When this procedure is followed (of shifting one sequence a unit at a time and compiling the run length statistics), the results substantiate Biasotti's hypothesis. Regardless of the phase relationship of one sequence with the other, the chance occurrence of consecutive matching lines exceeding those proposed by Biasotti did not occur. Due consideration was given to the fact that the simulated sequences were 3 or 4 times longer than Biasotti's actual bullet data.

SECTION IV

MEASUREMENT OF DEPTH OF GROOVE

The second specific objective, shown as item 2) in Subsection IIB, was to examine more closely the problem of the measurement of depth of groove, which is one of the class characteristics. In addition, it was planned to investigate surface profiling, a particular technique used to measure this class characteristic.

A. General

In the survey of firearms laboratories that was conducted under Phase 0, it was learned that, in general, only three class characteristics of a bullet are recorded or noted:

- 1) Caliber.
- 2) Number of lands/grooves.
- 3) Direction of twist.

These three characteristics can be determined by visual inspection, with little effort, and in most cases will adequately describe the bullet for the *examiner's* purposes.

The remaining three class characteristics can only be obtained through the use of some measurement technique. These characteristics are:

- 4) Width of the lands and grooves.
- 5) Pitch, or degree of twist of the rifling.
- 6) Depth of groove.

The last of these three (depth of groove) is the most troublesome to measure, when the various techniques available are considered. An additional reason for examining this parameter is the knowledge that the depth of groove is a function of the size of the bullet entering the chamber. Furthermore, there is great variability in the manufacture of ammunition, which sometimes results in bullets that do not completely fill the grooves as they pass through the bore, thereby altering the true measure of depth of the groove in the firearm.

When the returns from the questionnaire were re-examined, it was learned that only one laboratory (out of 46 responding) indicated it would measure this parameter. Even this response must be viewed with skepticism since the labora-

tory indicated that *all* class characteristics were always measured and recorded in only 10 minutes, thereby departing from the norm of 30 minutes average time required for measuring 3 or 4 of the class characteristics (items 1, 2, 3, and 4 above.)

It was desired to carefully examine the utility of this parameter before eliminating it as a required class characteristic.

The reasons stated above and discussions with firearms experts indicated that it would not be necessary to include the measurement of depth of groove as one of the characteristics considered.

B. Surface Profiling

Concurrently with the inquiry relative to the depth of grooves, a laboratory investigation was undertaken to determine the magnitude of the surface deformation of the bullet caused by surface profiling (e.g., techniques employing a stylus).

Lead, copper-jacketed, and lubaloy bullets were test fired and then taken to a commercial gauging company for subsequent profiling. The instrument used was a Bendix Profilorder. A typical recording of a single profile around a bullet is shown in Fig. 6 (photographically reduced). It can be seen that this technique could be utilized to produce measurements of the approximate and average depth of the grooves; however, the physical process involved — a sharp-tipped stylus moving over relatively soft metal — is such that the bullet surface is damaged and consequently information and data are destroyed or deformed.

To assess this deformation, the bullets, after being profiled, were examined with a Scanning Electron Microscope (SEM). Figures 7, 8, 9 and 10 show the SEM images and the resulting deformation caused by the stylus method of measuring depth of groove.

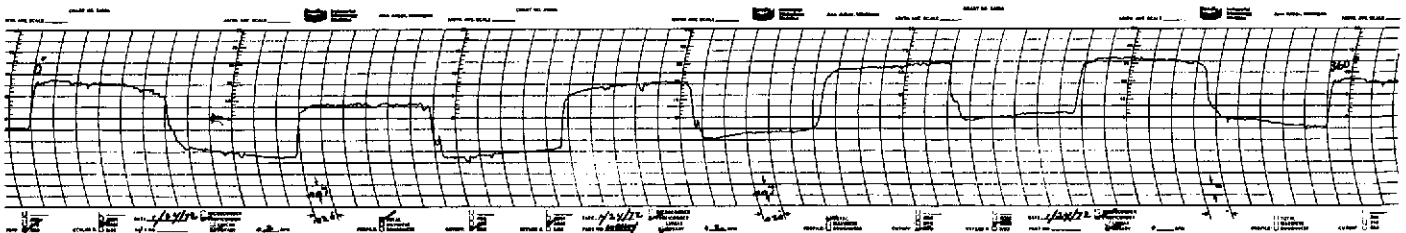

Figure 6. Typical surface profiling recording around a bullet

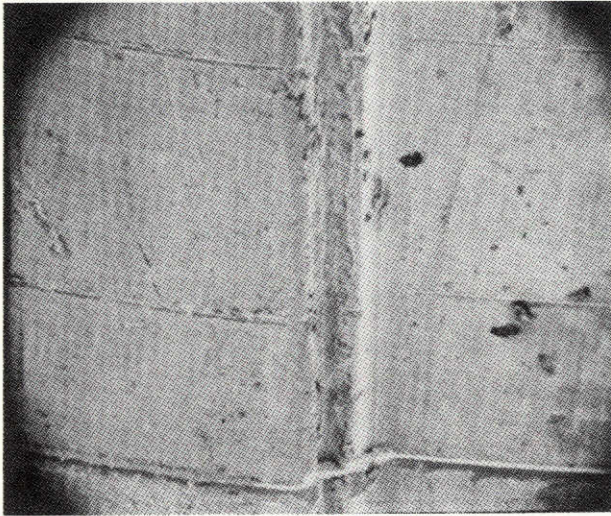

Figure 7. Lead bullet, 100X

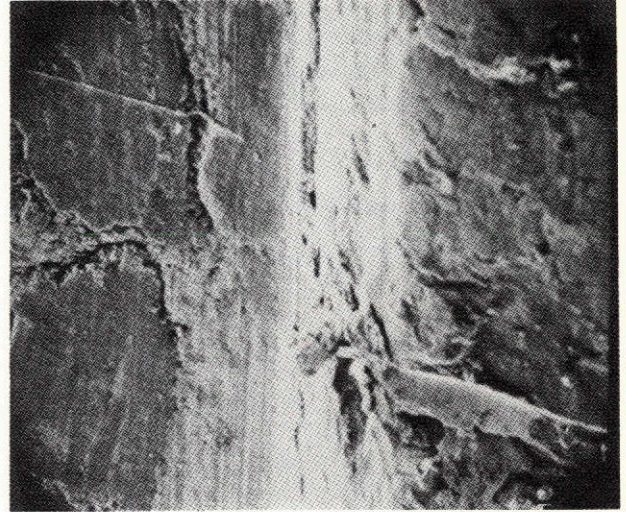

Figure 9. Lubaloy jacketed bullet, 500X

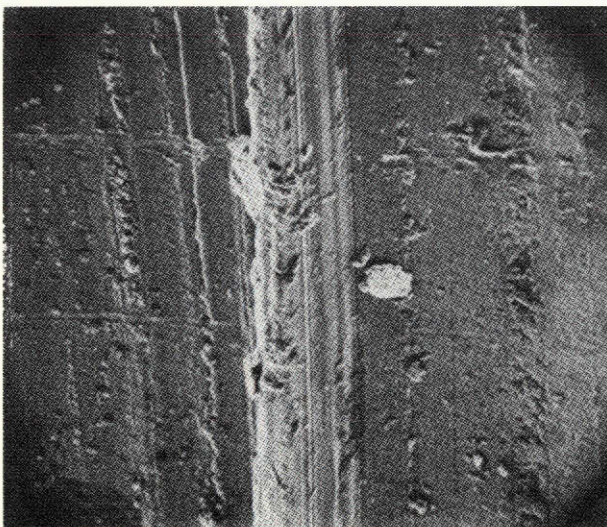

Figure 8. Three-fourths jacket bullet, 475X

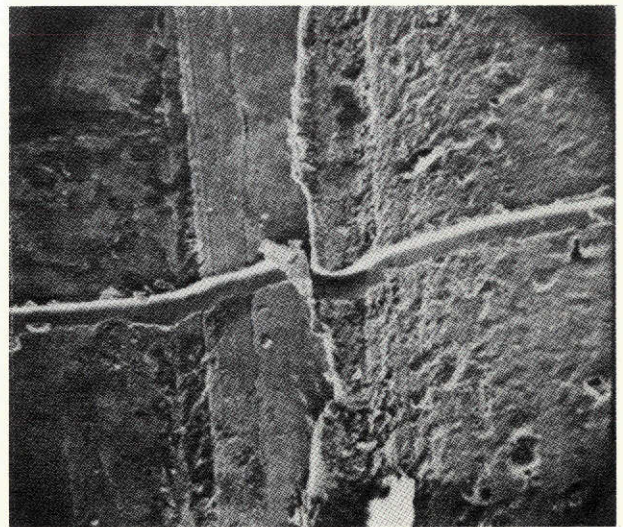

Figure 10. Full copper jacketed bullet, 525X

SECTION V

DEVELOPMENT OF GENERALIZED CONCEPTUAL SOFTWARE FOR AFIDS

The third specific objective, shown as item 3) in Sub-section II-B was to develop a generalized conceptual software system. The activity undertaken to meet this objective was directed to the application of existing computer algorithms and the development of new techniques to permit feature extraction and pattern analysis of bullet surface information.

To undertake the application and development of image processing programs, it was necessary to identify and implement a method of entering the bullet surface information into a computer. Initially, it had been proposed to use apparatus available at the LAPD Firearms Laboratory to photograph the exterior surface of a bullet. This equipment consists of a rotating slit camera that exposes film at a rate equal to that of a rotating drum upon which a fired bullet is set. The product is a photographic negative of the "unwrapped" bullet. During Phase 0 this technique was used to evaluate the applicability of this approach of getting bullet data into a computer.

The major disadvantage of this particular equipment is that the photographic image is recorded on a piece of 8 in. X 10 in. film. The subsequent photo reduction to approximately 70 mm (2-3/4 in.) for the format necessary for digital flying spot scanning by the Image Processing Laboratory caused serious degradation and significant loss of detail of striation information.

To overcome this shortcoming plus other logistical problems associated with using the equipment, a different and improved device was located.

Actron Industries, Inc., a subsidiary of McDonnell-Douglas Corp., has produced, in very limited quantities, a Balliscan camera which operates on the same principle as the device at LAPD Firearms Laboratory. It is basically an updated redesign of the LAPD equipment.

The advantages of this device are as follows: 70 mm recording film (the image is therefore directly scannable by the image processing laboratory scanner), higher intensity light source, more uniform drive train for bullet rotation, portability, and ease of operation.

Permission was granted by the Department of the Chief Medical Examiner-Coroner, City of Los Angeles, for limited use of their newly purchased Balliscan camera for demonstration purposes.

A. Test Data Accumulation

As mentioned previously, some limited test firings were conducted; bullets from these firings were to be used for software development. In addition, bullets from other sources were subsequently located.

Discussions with A. Biasotti revealed that he still had in his possession the .38 cal. revolver bullets used in his research (Ref. 2). He released a limited number of jacketed and lead bullets for use as a data source in software development.

The inherent advantage of using these bullets is that they have been completely mapped with regard to individual striations. Their use also permitted working with known data having defined statistical characteristics.

These test specimens were photographed by the Balliscan camera at the Los Angeles County Coroner's Laboratory.

B. Goals of Image Processing of Bullet Data

The fundamental ideas and approaches used in image processing of bullet data are complex. The basic intent is to introduce into the computer the "unwrapped" bullet image, as seen by the Balliscan camera and, subsequently, by the Image Processing Laboratory flying spot camera.

The image processing of bullet data has two basic goals:

- 1) Establish the group source of the bullet. This would include the quantification of its class characteristics:
 - a) Caliber.
 - b) Number of lands/grooves.
 - c) Direction of twist.
 - d) Width of the lands and grooves.
 - e) Pitch, or degree of twist of the rifling.

Note

A sixth class characteristic, depth of groove, has been rejected as a viable piece of data.

- 2) Develop a technique or approach that makes it possible to uniquely characterize the striations on a bullet so that identification can be accomplished.

In attempting to reach these goals one encounters a variety of problems, identification and isolation of which are part of this task.

Ideally, one would wish to develop a system in which each bullet is processed in such a way that a file can be built up in which the bullets are indexed in terms of class characteristics. This file would be keyed on caliber, number of grooves, left or right twist, etc. After this cataloging, the computer

would then process the bullet image for characterization of the striations. In this process, all detectable striations would be located and idealized. The computer would search for other bullets that have similar features by comparing profiles at selected points around the bullets and by comparing statistical properties. Should a match or near match be detected the two images would then be presented to the examiner for inspection and verification. Should no match be obtained, the data for the questioned bullet would be entered into the appropriate file.

In this process, all detectable striations above a certain threshold would be located and idealized. The threshold would be contingent upon the resolution capability of the input scanning device, and the striation exhibiting continuity along the bullet. That is, the striation must conform to a pre-specified set of minimum dimensions to qualify as a striation. The computer would then assess the statistical properties of the bullet at prescribed locations around the bullet. These statistical properties could, in fact, be similar to the data seen in sequence a, Fig. 5. The total number of striations seen and a breakdown of the various runs and their lengths could well form a code work for that particular band around the bullet. The computer would then search its files for bullets having a similar set of code words. The purpose of the code words would be to provide a file search capability for bullets of similar characteristics, having already eliminated those that did not match via class characteristics.

Figure 11 shows a schematic diagram of such a projected system. The individual elements are for the most part self-explanatory. There are three critical steps involved that will require considerable effort to develop. These three are titled on the schematic as

- 1) Image preprocessing.
- 2) Class Characteristics processing.
- 3) Process image for characterization of individual striations.

Item (1) is essentially a preconditioning step, necessary before proceeding to (2) and (3). The activity involved in (1) would include:

- 1) Decalibration of the Balliscan and flying spot scanning system.
- 2) Selection of an appropriate starting and stopping point to ensure only 1 revolution or 360° of data (since the Balliscan camera records, on the average, about 1-1/2 revolutions of the bullet).
- 3) Introduction of geometric rectification to correct for eccentricity of the Balliscan drive-rotation. (The eccentricity is caused by inability to set the bullet perfectly flat on the rotating drum on the Balliscan.)

The correction action is accomplished by geometric rotation of the "unwrapped" image in the

computer, with the circumference of the bullet (i.e., the part which represents the unwrapping process) perfectly parallel to the edge of the photograph.

Figures 12 and 13 show the results of this process. Figure 12 is a scanned photograph of an unwrapped bullet. This image exhibits a scan (by the Balliscan camera) in which the bullet was rotated slightly off center. This is seen in the photo as a relative displacement of the top of the frame shifted to the right relative to the bottom. In addition, Figure 12 contains more than 360° of rotation (some of the same features can be seen twice). Figure 13 illustrates a geometric correction for the off-center rotation and an elimination of the excess scan, so that the picture now contains exactly 360° of data (1 full rotation).

- 4) An additional step could include a subjective enhancement step to increase visual resolution of features. This could be accomplished by contrast stretching or by the application of specially designed digital filters to increase contrast.
- 5) Another step might include magnification or demagnification changes via geometric rectification steps to restructure the data to 2^N size for subsequent Fourier transformation. Figure 14 shows the transformation of Fig. 13 (960 lines, 320 samples) to 1024 lines, 256 samples (i.e., $2^{10} \times 2^8$).

Item (2) is the feature extraction process whereby the class characteristics of the bullet will be measured. It is not yet clear whether this process should be interactive, with the examiner using the scanned image to supplement the characteristics he observes, or if the entire process should be automatic.

Several of the class characteristics can be easily acquired visually by the examiner. Class characteristics such as caliber, number of lands and grooves, and direction of twist can be determined very quickly and entered into the system along with case number, bullet type, weight, and other required observables.

The other characteristics can be obtained by computer processing techniques. Pitch and widths of lands and grooves are difficult to measure manually and can be acquired by appropriate digital techniques.

One technique, which has been tried briefly, is the conversion of the bullet image to frequency space through the Fourier transform. Figure 15 is the Fourier transform of the geometrically rectified bullet image seen in Fig. 14.

Analysis of Fig. 15 will yield the pitch direction, pitch angles, and the number of lands/grooves and perhaps additional parameters leading to other class characteristics. It is clear that filtering techniques in the Fourier domain can be

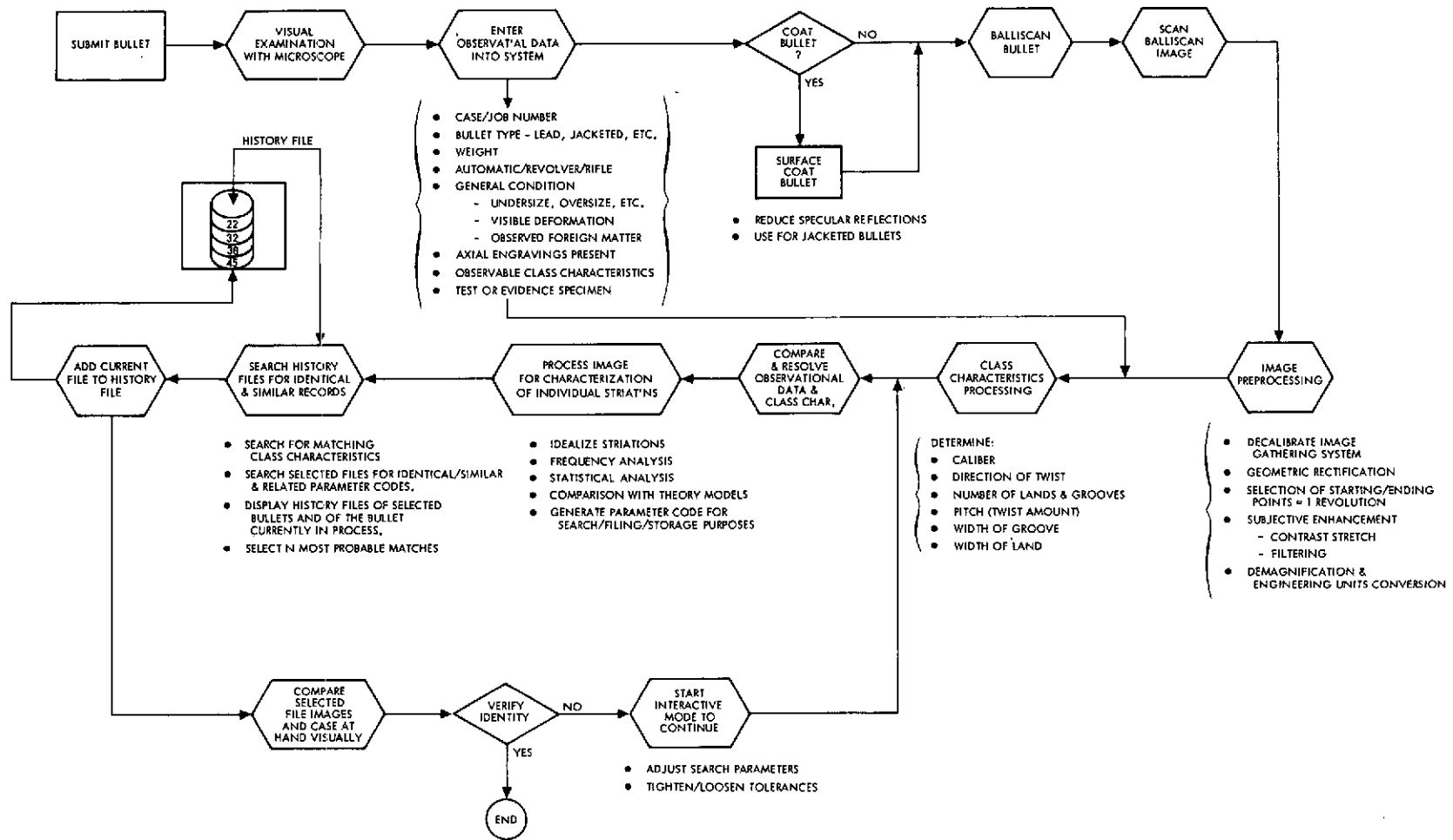

Figure 11. Schematic diagram of image processing system for bullet data

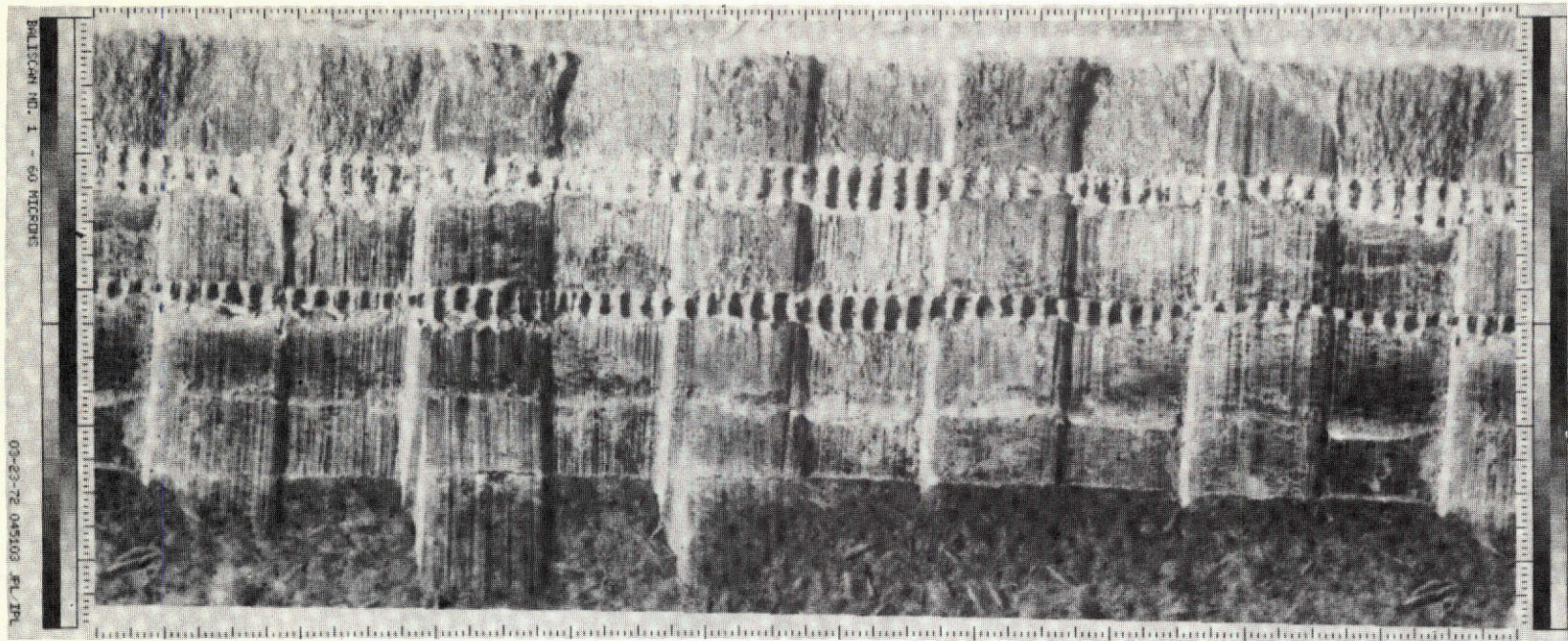

Figure 12. Scanned photograph of an "unwrapped" bullet

15

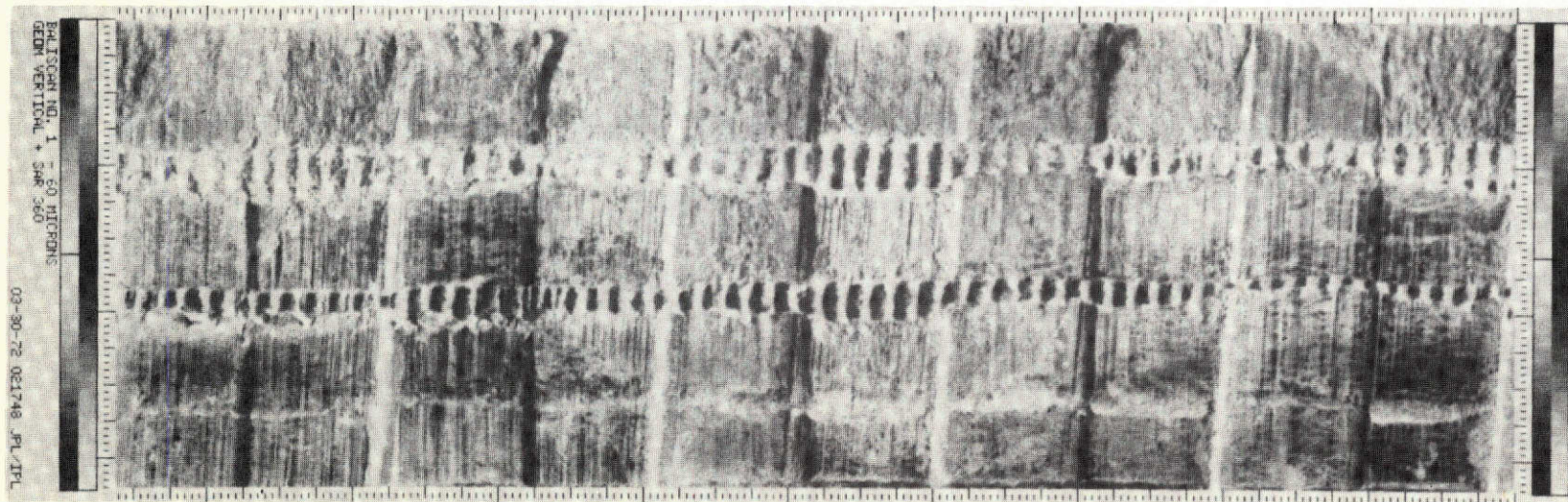

Figure 13. "Unwrapped" bullet image after geometric correction for off-center rotation and elimination of excess scan

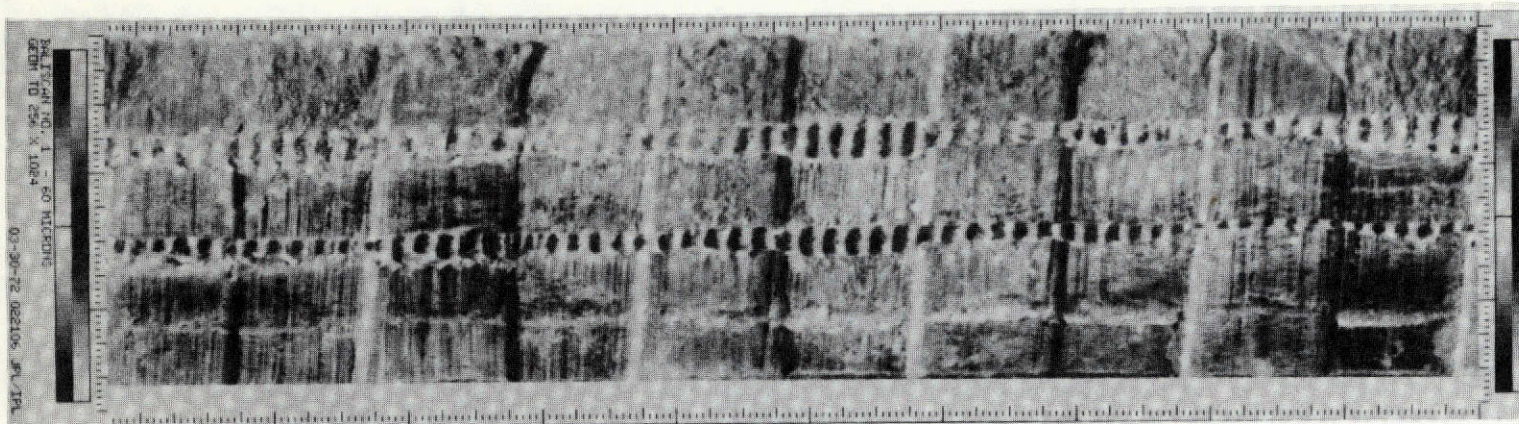

Figure 14. Geometric transformation of Fig. 13, to permit Fourier transformation

16

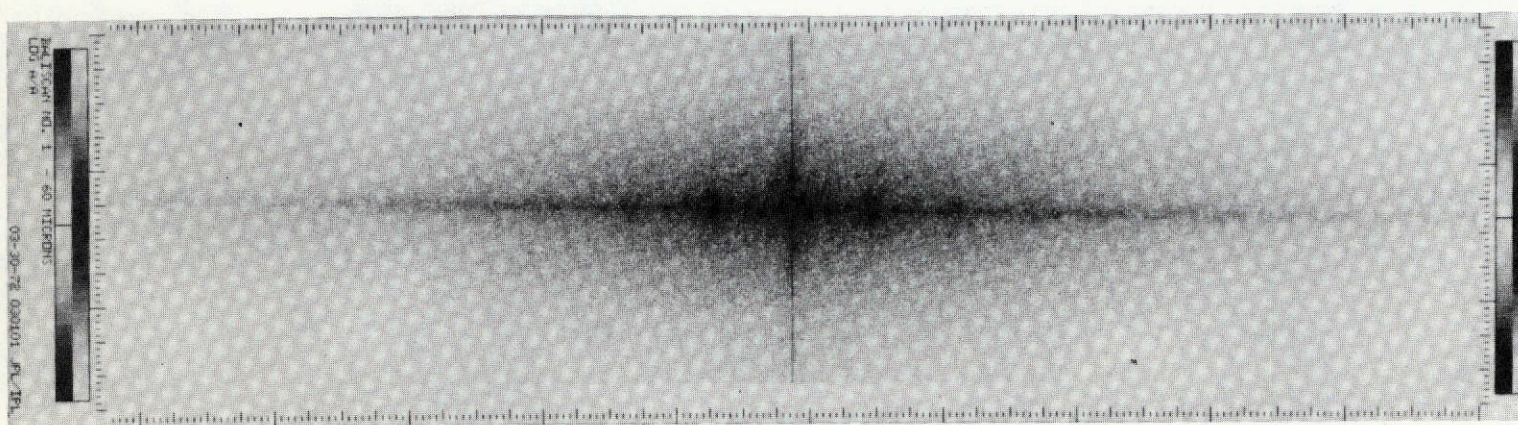

Figure 15. Fourier transform of geometrically rectified bullet image of Fig. 14

applied to allow additional enhancement to be developed. Specific frequency components can be selected and, after back transformation to the real image, other programs may be applied to determine more accurately the width of the lands and grooves.

Item 3), the final critical process to be developed and tested in any proposed automated system, is the development of a method of processing, characterizing, and encoding for search purposes the individual striations on a bullet.

The first step in this proposed process will be to convert the preprocessed image to the extent necessary to achieve idealization of the individual striations.

The primary reason for the idealization step is to reduce the problem of attempting to correlate gray-scale photography. Because of basically inconsistent processes involved in photographing and scanning any subject, the problem of computer interpretation of the shape, width, and contour of individual lines and subsequent comparison with other lines in other photographs would be too large to overcome.

To idealize a striation the first derivative test for maxima and minima was applied. What is essentially being sought is a local test for critical values of a function. At each point where a local maximum is located (with some corresponding minimums), the original line or striation is replaced with a single black line.

Figure 16 shows such an idealization process. The top portion of Fig. 16 shows a portion of a Balliscan image. The bottom half of Fig. 16 shows the idealization process as applied to the upper half. The process is repeated in Fig. 17, but in this case the amplitudes which are accepted must be slightly larger.

The next step would be production of specific statistical parameters similar to those in Fig. 5. A series of these records would be produced for various bands around the bullet. Six to 10 bands would probably be adequate to cover the bullet surface.

The comparison process could consist of the following steps:

- 1) Locate the best group source (i.e., class characteristic of specimen at hand vs best matched class characteristic from history file).
- 2) Perform the comparison phase in the following steps:
 - (a) Locate any band in the history file that contains statistical parameter code words that are similar or identical to those for the bullet under test. (These code words would indicate number of striations and run lengths, and give a probability estimate.)
 - (b) Upon locating a specific band in the history file having similar statistical parameter code words, begin to compare the band from the bullet in question to the band from the history file. Repeat this process, at slightly different rotations of the suspect band relative to the history band; repeat until all possible orientations are completed. The end product will be a best possible match, with a display of the various run lengths at the best orientation. Specific cutoffs and thresholds may be developed to prevent or reject obviously bad matches which do not meet the criteria of consecutive runs.
 - (c) Verify these computer-produced matches by visual examination.

It should be recognized that the steps outlined above assume that the bullets scanned and processed have not been severely damaged or deformed. The ability to process deformed bullets could only be achieved – if at all – through a major rethinking of the total system concept.

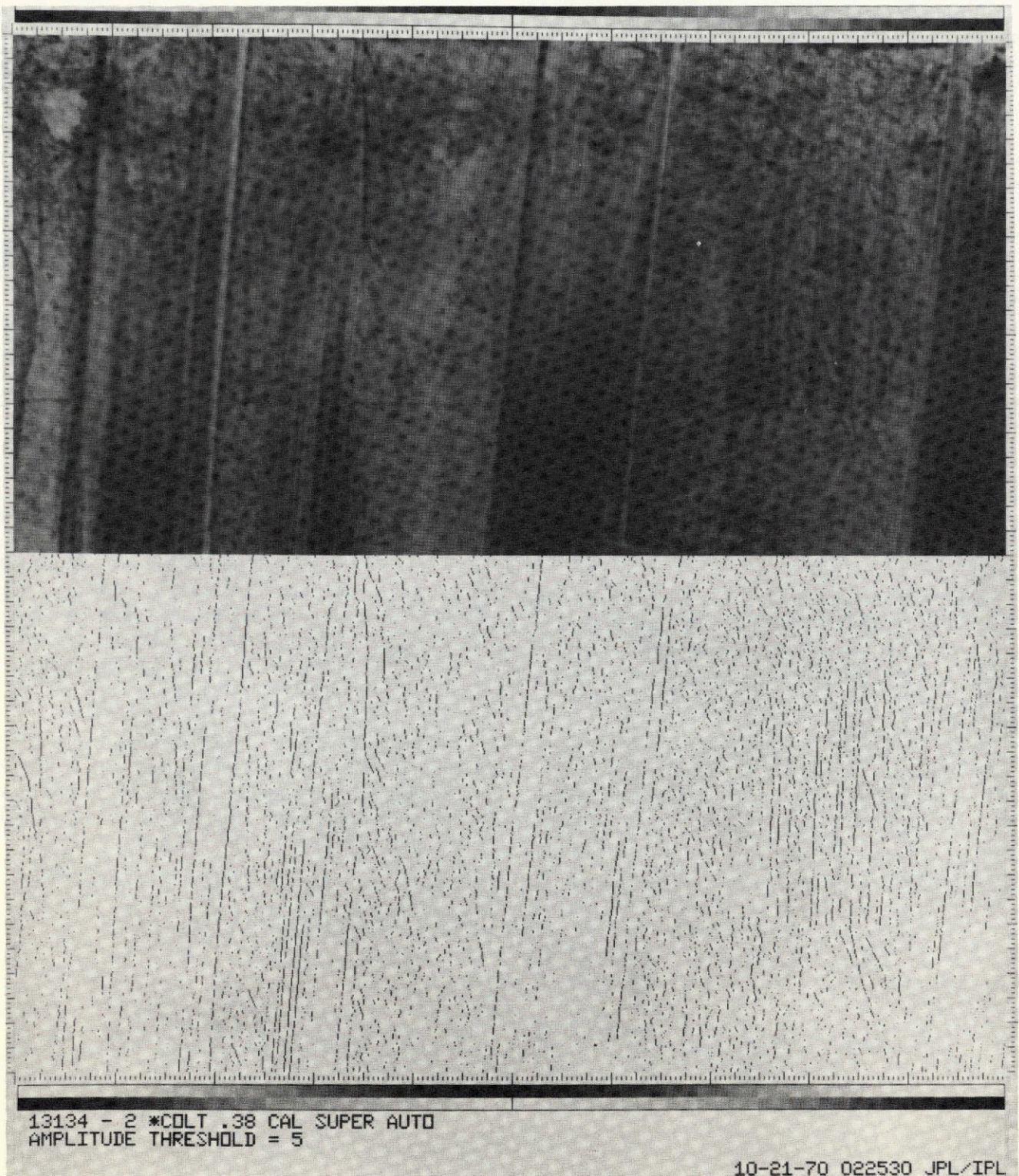

Figure 16. Idealization (bottom) of bullet image - amplitude threshold 5

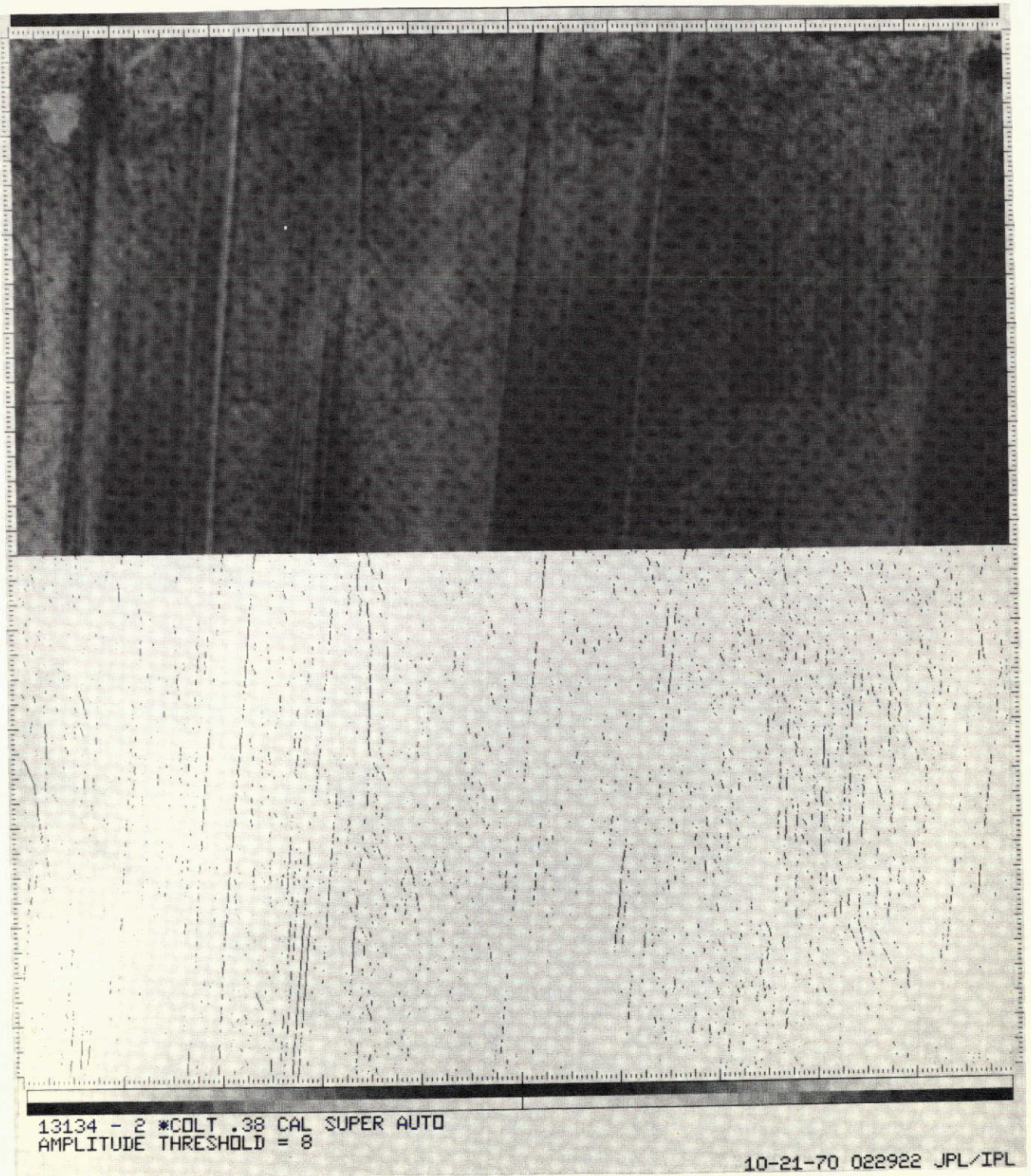

Figure 17. Idealization (bottom) of bullet image - amplitude threshold 8

SECTION VI

CONCLUSIONS AND RECOMMENDATIONS

A. Conclusions

The primary objectives of this initial phase, which was to investigate critical technology items relating to the development of automatic firearms identification, have been accomplished.

The problem of reproducibility of individual striations has been investigated and it has been found that striae will be retained for sufficient periods with specific weapons depending upon use and user.

A simulation study was conducted to verify that the statistics properties of random number sequences closely parallels the characteristics of striations seen on individual bullets.

A literature search was conducted in which it was learned that there is currently no universal factual basis for establishing identity of a firearm. Biasotti (Ref. 2) has conducted research which could prove very useful to future developments in firearms identification.

A series of test bullets were measured with a surface profiler and then examined with a scanning electron microscope. It was found that serious deformation of the bullet surface resulted from the profiling.

Finally, a generalized concept for the development of a software system to support an automated firearms identification system has been proposed.

B. Recommendations

During the course of this investigation considerable insight and interest has been developed into the problems encountered in firearms examination. It has been found that there has been no measurable technical growth in an area greatly in need of assistance.

It is believed that some initial steps should be taken so that firearms information can at least be communicated. This could be accomplished simply by developing a retrievable and expandable file of existing firearms classification data currently available from many diverse sources. Included in this file or in addition to it could be a manually compiled file of open-case bullet characteristics for all unidentified bullets.

The development of an automated system similar in nature to that described in this report could be a natural follow-on effort which would complement the manually produced classification system.

REFERENCES

1. Cross, E., "The Origin of Some Markings on Fired Bullets," *RCMP Gazette*, 13:9, pp. 5-10, Sept. 1961.
2. Biasotti, A. H., "A Statistical Study of the Individual Characteristics of Fired Bullets," *Amer. J. of Forensic Sciences*, 4:1, pp. 34-50, Jan. 1959.
3. Lucas, A., *Forensic Chemistry and Scientific Criminal Investigation*, 2nd Ed., Edward Arnold and Co., London, p. 324, 1931.
4. Burd, D. Q., and Kirk, P. L., "Tool Marks, Factors Involved in Their Comparison and Use as Evidence," *J. Criminal Law and Criminology*, 32-36, pp. 679-686, Mar.-Apr., 1942.
5. Burrard, G., *The Identification of Firearms and Forensic Ballistics*, 1st American Edition, A. S. Barnes and Co., New York, pp. 165-166.
6. Brackett, Jr., J. W., *A Study of Idealized Striated Marks and Their Comparisons Using Models*, paper presented at the 26th Semiannual Seminar of the Calif. Assoc. of Criminalists, Stateline, California, Oct. 22, 1965.

APPENDIX
AUTOMATED FIREARMS IDENTIFICATION
SYSTEM (AFIDS): PHASE 0

SECTION I
INTRODUCTION

A. Firearms Identification Problem

The use of firearms in the commission of crimes is increasing rapidly in the United States. The ability of firearms examination laboratories to keep abreast of this increase is often hampered by a lack of trained personnel, by examination methods which are outdated and inexact, and by inability to communicate specific firearms examination data to and from other agencies.

The function of the laboratories in the large metropolitan cities such as New York, Chicago, Washington, D.C., Los Angeles, Philadelphia, etc. is often reduced to one of cataloging firearms. The ability to search files for comparisons is greatly reduced and hampered by antiquated and/or poorly organized and maintained filing systems.

B. Phase 0 Overall Objectives

A program was undertaken to examine the firearms identification problem in greater depth. The initial investigations undertaken in preparing a Phase 0 plan indicated that the technology existed to provide a potential solution to the firearms identification problem. The need, from preliminary inquiries, existed. Finally it appeared that the development of an automated-type of firearms identification system could be accomplished within a reasonable time-span and with bounded costs.

In summary, the overall objectives of the Phase 0 plan were to validate the need and to establish the requirements for an automated system. Additionally, it was necessary to examine alternative approaches for bullet examination and analysis of data.

C. Specific Phase 0 Objectives

The specific Phase 0 objectives contained within the Phase 0 task plan are as follows:

- 1) Conduct surveys of firearms laboratories for the purposes of:
 - a) Surveying prospective users of the proposed Automated Firearms Identification System (AFIDS) on their requirements and need for such a system.
 - b) Acquiring technical data regarding rifling and bullet classification and identification specifications.
- 2) Identify and evaluate alternative approaches to measuring the surface characteristics of various classes of bullets.
- 3) Establish the validity of using data processing techniques on representative recorded profiles of the surface characteristics of bullets. Examination into the reduction of these records into standard specifications will be made.
- 4) Development of the functional and performance requirements for a firearms identification system shall be prepared.

The accomplishment of these goals and objectives and the results obtained are discussed in Section II, Summary of Phase 0 Results.

SECTION II

SUMMARY OF PHASE 0 RESULTS

The goals and objectives as outlined in Section I were accomplished as described below.

A. Laboratory Survey

A firearms laboratory survey was conducted to assess requirements and to establish the need for an automated system.

A questionnaire, containing 33 questions, was sent to the entire membership of the Association of Firearms (AFTE) and Tool Mark Examiners. In addition, other selected groups and individuals, known to be active in firearms examination, but not members of AFTE, were included in the survey.

AFTE, the Association of Firearms and Tool Mark Examiners, is not a large association. An analysis of its membership shows that its 168 members have the following affiliations:

- 25 city-level laboratories
- 11 county-level laboratories
- 17 state-level laboratories
- 10 federal-level laboratories
- 63 laboratories

In addition, the following affiliations were noted:

- 3 educational institutions
- 4 commercial organizations
- 9 of unidentifiable affiliation (probably interested non-professionals or retired examiners)

For statistical purposes the 46 responses from the 63 laboratories shown above represent a 73% return on the questionnaires.

Attached to the questionnaire were two cover letters. The first was from Dewayne A. Wolfer, an officer of the Association and Chief Forensic Chemist, Los Angeles Police Department and consultant to the AFIDS task. The objective of this letter was to have Mr. Wolfer introduce the membership to JPL and to request their cooperation in the survey. The second letter, from Dwain F. Spencer, Manager, Space Technology Applications, and also directed to the Association member, described what role JPL has in the task, the purpose of the questionnaire, and also requests their cooperation.

A summary of the salient features of the collective responses to the questionnaire shows the following:

- 1) The large laboratories (those employing 5 or more full time examiners) with a large case load (those with more than 100 examinations per month) were the most interested in AFIDS.
- 2) 60% of the laboratories reported that they believed some form of automation would be required in the future.
- 3) 53% of the laboratories reported access to a computer, but only 8% indicated they used it. These 8% stated that computers were used to store stolen firearms serial numbers and descriptions.
- 4) The increased work load for firearms examination is reflected in an expected 14% increase in new examiners.
- 5) 74% of all firearms which are submitted for examination are test-fired and the bullets subsequently examined.
- 6) 81% of all bullets examined are of the following caliber: .22 cal. (43%), .38 cal. (29%), and .32 cal. (9%).
- 7) 16% of the laboratories use three class characteristics to establish the name of a firearm (caliber, direction of twist, and number of lands/grooves). 71% of the laboratories indicated that four characteristics were used (same as above plus width of lands and grooves). An additional 4% indicated that they would also include depth of groove information and 6% indicated that they would include pitch of the grooves data if required.
- 8) The average time required for class characteristic examination is 31 minutes.
- 9) The average salary for an examiner is \$11,563.
- 10) 91% of laboratories considered the capability of transmitting or receiving bullet data a needed and beneficial capability.

The laboratory survey questionnaire returned relevant and suggestive data. Because of the representative nature of the sample, generalizations about United States firearms laboratories can be considered valid.

The data obtained indicates that the members of the Association of Firearms and Tool Mark Examiners are generally optimistic about the potential aid automation will offer.

Laboratories in Los Angeles, California, Chicago, Illinois, Lansing, Michigan, Philadelphia, Pennsylvania, and Washing-

ton, D.C. were visited. Discussions with the personnel and directors of these laboratories provided insight into laboratory functions and problems. The visits also permitted the exchange of ideas and data relative to firearms examination.

B. Identification and Evaluation of Alternative Approaches To Measuring the Surface Characteristics of Various Classes of Bullets

An extensive review of potential bullet scanning instrumentation was performed. This review was undertaken to identify alternative methods to accomplish qualitative and quantitative measurements of the various parameters of a fired bullet to facilitate firearms identification.

This review, conducted by R. Woodbury, of Section 374, Environmental and Dynamic Testing, was accomplished using the following evaluation criteria to assess the instrumentation:

- 1) Resolution.
- 2) Accuracy.
- 3) Repeatability.
- 4) Reliability.
- 5) Operating constraints.
- 6) Ease of implementation.
- 7) Speed.
- 8) Data outputting capabilities.
- 9) Cost.

The two systems which were recommended have some resemblance to each other. Both are optical scanning devices in nature and both will ultimately utilize image processing techniques to achieve quantification of the class and individual characteristics.

1. Television Microscopy

The first method recommended is that of television microscopy. In its simplest form, a television camera head may be attached to a microscope. With the appropriate electronics the video information may be displayed on a CRT tube and digitized for storage and/or subsequent processing by computer.

One of the primary advantages of considering this method is that a system presently exists which is a close counterpart to that which is needed. The system research tool, in use within the Space Science Division, is called an Automated Light Microscope System (ALMS) and is used in bio-medical research. This instrument is basically a conventional microscope except that four functions have been placed under computer control:

- 1) Microscope stage translation in two directions within the specimen plane.
- 2) Stage translation in the focus direction.
- 3) Substitution of various optical filters in the illuminating beam.
- 4) Operation of the image scanning camera.

Functions (1) and (2) allow the implementation of slide search and automatic focusing algorithms. Function (3) provides control of the intensity and spectrum of the illuminating beam. Function (4) provides the capability to scan and digitize a specified rectangular field of variable size and sampling density.

The Automated Light Microscope System (ALMS) configuration is shown in Fig. A-1. The microscope is under closed loop control of a dedicated IBM 1130 computer. The stage is driven by digital stepping motors. An eight position filter wheel, also driven by a stepping motor, allows substitution of optical filters in the illuminating beam. A closed circuit TV camera displays the field of the objective lens on a monitor located beside the computer console. An image plane scanner controlled by the 1130 feeds a digital picture of the microscope image into the machine.

The supervised specimen search, automatic focusing, and scanning are implemented on the 1130. The digital pictures obtained by the ALMS are transferred over a data link to an IBM 360/44 computer in JPL's Image Processing Laboratory.

2. Laser Scanning

The second alternative is a laser scanning device. It involves scanning the surface of a bullet with a focused laser beam and collecting the scattered light with photomultipliers for video processing and display.

The purpose of the laser is for illumination, not for the development of holograms, etc. The intensity of a focused laser beam is several orders of magnitude greater than the focused beam of the highest intensity incoherent source known. The laser also eliminates the need for optical gratings, irises and other devices associated with the generation of pseudo-monochromatic light from an incoherent source. Another advantage of using the laser is that it permits the use of inexpensive detectors because of the high signal to noise ratios available. In addition, because of the single frequency nature of the laser, sharp bandpass optical filters can be used to reduce ambient light in the vicinity of the target.

Some of the associated problems which have been encountered by others using lasers have not been assessed or evaluated, problems such as diffraction rings caused by dirt, etc., or light scattering due to the coherence of the laser.

Two techniques would be available using the laser scanning system. The first would be sector scanning in which the bullet remains stationary and a light raster generated by

horizontal and vertical deflection of the laser beam is focused onto a desired sector on the bullet.

The second technique, and perhaps more useful, is the "unwrapping" of the cylindrical surface of the bullet. To do this the bullet must be rotated through a single laser line scan (i.e., the vertical deflection of the laser beam is omitted, resulting in a single trace of light at the target, representing solely the horizontal deflection of the beam).

The measuring techniques which were reviewed and subsequently rejected are listed in Table A-1. Also shown are the reasons for the rejection.

It was found that several of the methods examined were able to accomplish measurements of one or two or even three of the required class characteristics. However, all had one or more serious disadvantage which would eliminate it from consideration. It was also found that the eventual rotation of either bullet or sensor would impose constraints which would also introduce complexities into the system under consideration.

Other considerations, less obvious than those criteria listed above, contributed to the elimination process. Such things as familiar and accepted techniques of examination, ease of understanding and operation, contacting probe versus non-contacting probe, environmental considerations (temperature, humidity) of the bullets, etc. also were noted.

C. Establish the Validity of Using Path Processing Techniques on Representative Bullets

There were two types of bullet data examined in approaching this objective. The first was obtained from a commercial meteorology laboratory by stylus methods. This type of data is considered profile information. Some of the characteristics of profile data are as follows:

- 1) Yields a direct measurement of depth of groove and some individual striae depths.
- 2) Difficult to visualize the surface features of the bullet along its long axis.
- 3) Minimum amount of data to examine and process.
- 4) Individual characteristics are frequently poorly discriminated.

An example of profile data is shown in Fig. A-2. The other type of data, image information, as gathered by a camera or some similar device, has the following characteristics (see Fig. A-3):

- 1) Good visualization of the bullet surface features.
- 2) Depth of groove and striae are not directly easily available from the data.

Table A-1. Rejected measuring techniques

| Method | Reason for Rejection |
|------------------|--|
| 1. Stylus | <ol style="list-style-type: none"> 1. Slow. Produces one line on data per scan. 2. Contacting. Scratches surface. 3. Cannot be used for large scale examinations. |
| 2. Ultrasonics | <ol style="list-style-type: none"> 1. Poor lateral resolving power (lines/mm). 2. Limited to diameter measurements. Beam penetrates material. 3. Narrow field of inspection. Requires scanning using servos. 4. Calibration and impedance matching. Difficult and critical for qualitative measurements. |
| 3. Microwaves | <ol style="list-style-type: none"> 1. Poor lateral resolving power. 2. Calibration relative. Cannot be calibrated to a usable standard. 3. Value limited to measuring changes in surface characteristics. 4. Cannot measure diameters. |
| 4. Eddy Currents | <ol style="list-style-type: none"> 1. Poor lateral resolving power. 2. Penetrates surface of material. 3. Narrow field of inspection. Requires scanning using servos. 4. Sensitive to metallurgical properties. |
| 5. Capacitance | <ol style="list-style-type: none"> 1. Poor lateral resolution. 2. Calibration sensitive to humidity. 3. Probe alignment critical. 4. Narrow field of inspection. Requires scanning using servos. |
| 6. Air Gages | <ol style="list-style-type: none"> 1. Poor lateral resolution. 2. Probe alignment critical. 3. Narrow field of inspection. Requires scanning using servos. |

- 3) Maximum amount of data to examine and process.
- 4) Adaptable to feature extraction and pattern analysis algorithms.

The resulting selection of an approach to measuring the surface features of a bullet were partly guided by the above listed characteristics as well as those listed under alternative approaches.

It is noteworthy that profile data will yield more direct measures of class characteristics. That is, all six class characteristics can be determined by analysis of two or more strategically positioned profiles of data from around the circumference of a bullet. However, the correlation of striae of individual characteristics is difficult at best.

Image data, (i.e., camera, television, laser scans, etc.) represents the other extreme in amounts of data obtained. Computer processing of image data will yield all class characteristics but depth of groove and striae. This parameter could be obtained by more elaborate computing methods or by using interferometry methods.

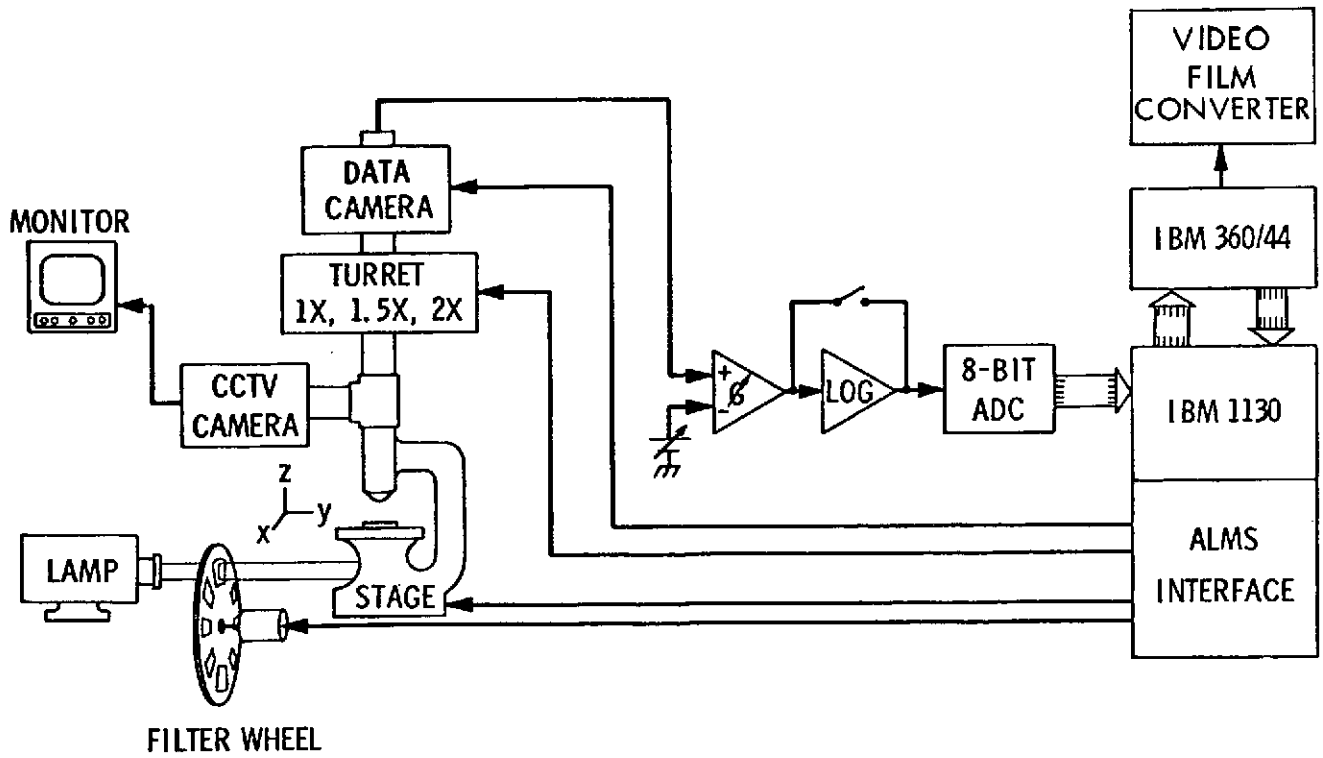

Figure A-1. Automated light microscope system

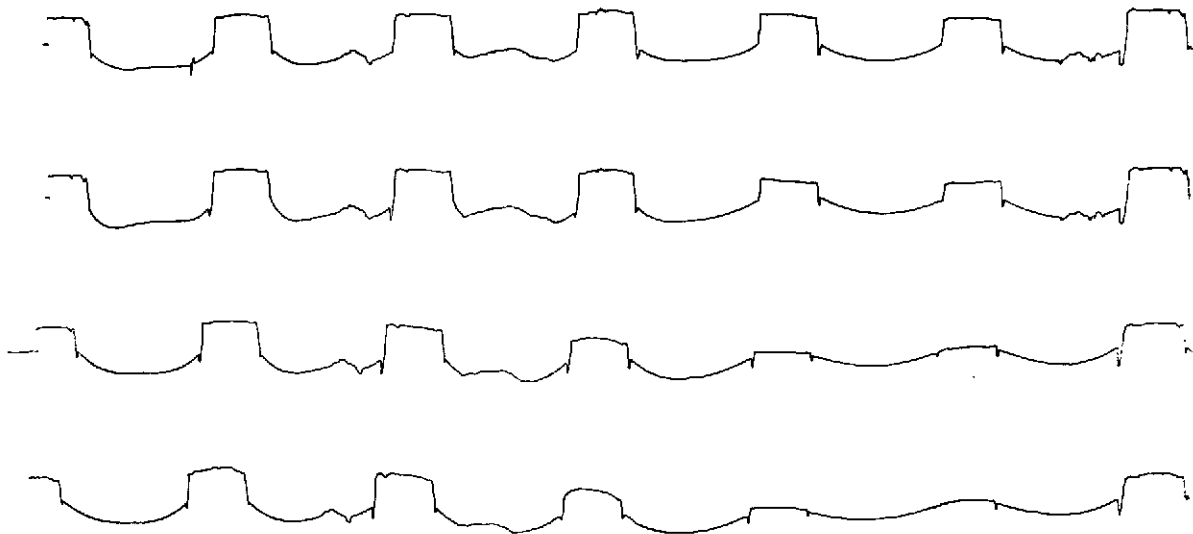

Figure A-2. Samples of profile data obtained by stylus methods. Note how groove definition changes. This is caused by obtaining profiles close to the base and nose of the bullet

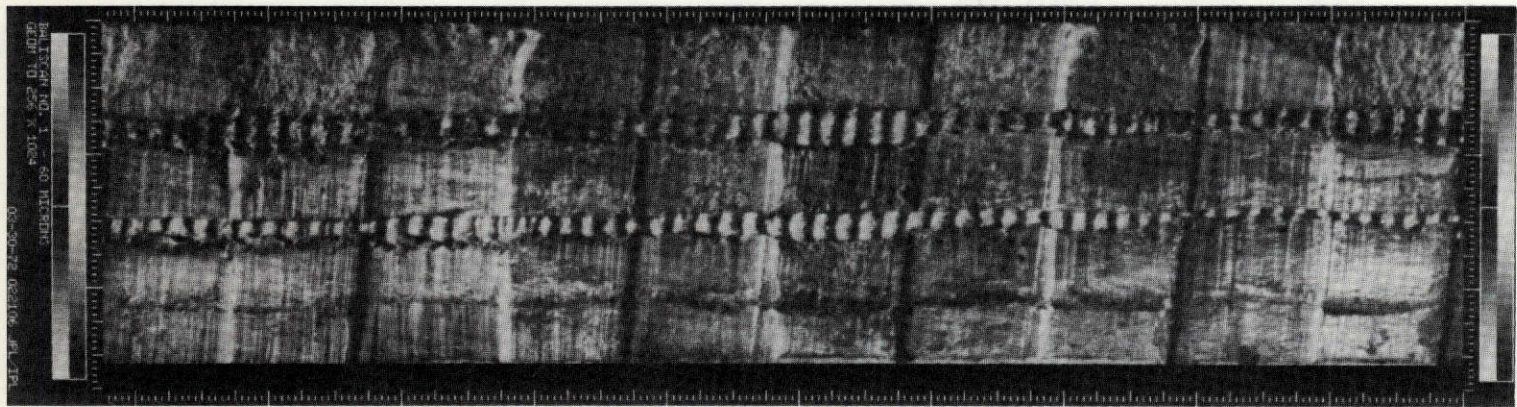

Figure A-3. Example of image-type bullet data

One of the prime advantages of using image characterization of bullets is the adaptability of this type of information to computer algorithms specifically oriented towards feature extraction and pattern analysis. An additional feature which was considered was the ability to transmit, by telephone or other methods, image data. An image from a TV or laser scanner can be transmitted to another agency and can be used for comparison purposes to real data or bullets under a microscope or to other photographic data. This cannot be done with profile data. Profile information can be communicated, but would be of limited value for comparison purposes.

During the Phase 0 period, profile and image data were examined for the purposes of attempting to identify bullets. It is possible, for example, to discriminate between bullets by computing the power spectrum of various profile data. The process is one of computing the amounts or power of the various frequencies within the profile. It is believed that similar processes would apply to image data as well.

Other programs, designed as preprocessing steps for image enhancement purposes, were applied to assess the utility of such programs and gain familiarity with bullet image data.

D. Development of Functional and Performance Requirements

As a result of the activity undertaken in meeting the prior three objectives, it is possible to begin to develop functional and performance requirements for an AFIDS.

Based on the data gathered from the firearms laboratories it is possible to establish some bounds on both functional and performance requirements.

There are obvious difficulties in attempting to establish correlations between budgets, costs, case loads, needs, desires and other criteria. From the functional standpoint it is possible to state that the AFIDS which does evolve must be capable of examining and characterizing a class of bullets for both class and individual characteristics. The characterization, being an image, will be subject to certain computer processes in order to establish classification and/or identification. From discussions with firearms examiners it was also determined that the ability to rapidly transmit to another agency the image of a bullet, would be a distinct capability which would increase significantly the laboratory effectiveness.

Functions which are unclear in their utility and need would include such things as:

- 1) The ability to do sector (raster) scanning on specific areas of bullets. This would permit system examination of badly deformed bullets.
- 2) Should the system be capable of examining two bullets at the same time?
- 3) Should the software algorithms which will evolve for feature extraction, pattern analysis and eventual identification emulate the contemporary processes now undertaken?

From the performance standpoint, it can be stated that the system must be competitive with contemporary measurement methods and with the results from such methods. The factors of cost, speed, utility and results are key parameters in assessing and establishing performance requirements.

SECTION III

CONCLUSIONS AND PHASE I GOALS

The primary objectives of Phase 0 have been met. An in-depth assessment of the needs and present status of 44 firearms laboratories in the United States has been made. Information, both quantitative and narrative, has been provided which is valuable to the future design of an Automated Firearms Identification System.

Various data from representative bullets has been examined and it is believed that the subsequent development of feature extraction and pattern analysis algorithms can provide the process necessary for identification.

Equipment which is within the state of current technology is available for bullet examination. The adaptation of this equipment to the purposes of firearms examination and identification is an objective of a subsequent Phase I effort.

Economic considerations have not been examined in detail. It can be shown that most firearms laboratories could not be expected to purchase an automated system whose price is in excess of several hundreds of dollars. This is because there are no budget dollars available for new equipment purchase.

Funding assistance will be necessary from state and national levels.

The potential return from a fully automatic and operational system is significant. It will be possible, probably for the first time, to compare bullets in an open file from one city with those of another. Laboratories will be able to routinely compare each new piece of evidence with that currently in the active file.

The firearms laboratory can begin to assist the other areas of law enforcement by now contributing to the solutions of past crimes.