

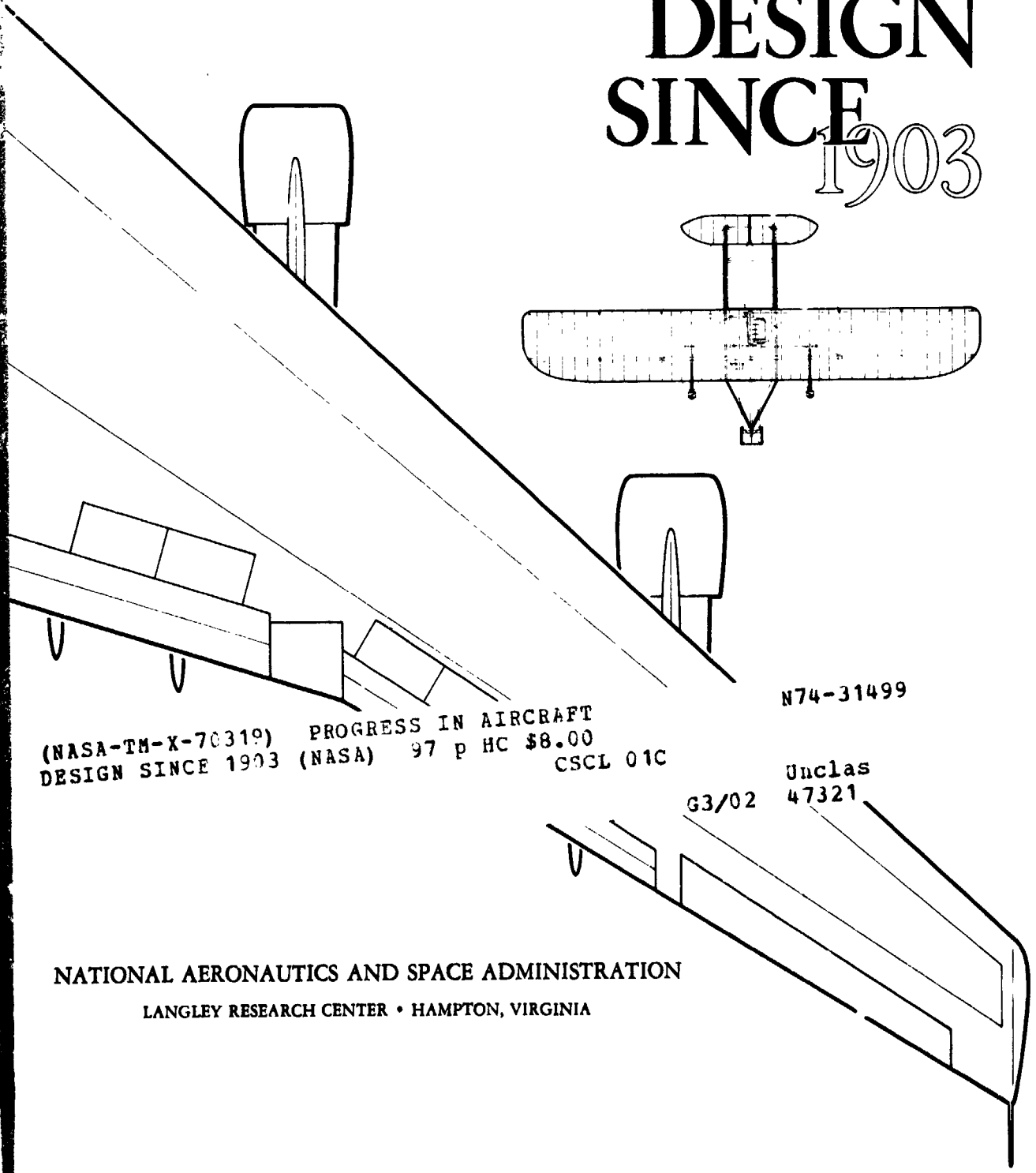

PROGRESS IN AIRCRAFT DESIGN SINCE 1903

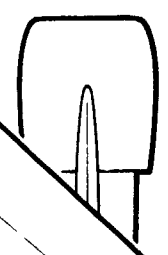
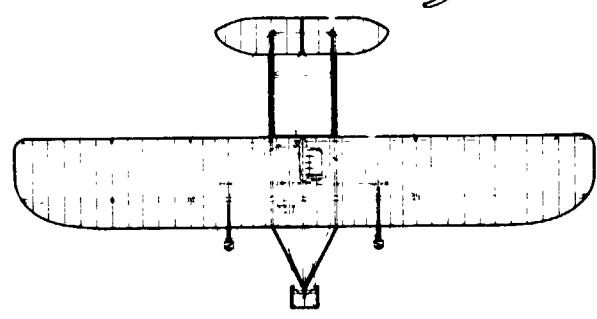
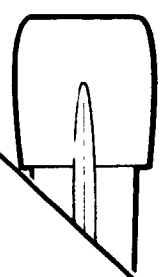

(NASA-TM-X-70319) PROGRESS IN AIRCRAFT
DESIGN SINCE 1903 (NASA) 97 p HC \$8.00
CSCL 01C

N74-31499

Unclas
G3/02 47321

NATIONAL AERONAUTICS AND SPACE ADMINISTRATION
LANGLEY RESEARCH CENTER • HAMPTON, VIRGINIA

TABLE OF CONTENTS

AIRCRAFT	PAGE	AIRCRAFT	PAGE
Aeronca C-2	28	Granville Bros. R-1 "Super Sportster"	33
Beech Model 18	42	Grumman F3F-2	36
Bell Model 204	73	Grumman F4F-3 "Wildcat"	43
Bell P-59A "Airacomet"	57	Grumman F8F-1 "Bearcat"	60
Bell XS-1	63	Grumman F-14A "Tomcat"	92
Blériot XI	5	Handley Page O/400	7
Boeing Model 40B	23	Hawker Siddeley "Harrier"	88
Boeing Model 80A-1	27	Kellett YO-60	58
Boeing Model 367-80	71	Lear Jet Model 23	84
Boeing Model 377 "Stratocruiser"	64	Lockheed 1049 "Super Constellation"	68
Boeing Model 727	82	Lockheed P-38F "Lightning"	47
Boeing Model 737	89	Lockheed P-80A "Shooting Star"	59
Boeing Model 747	90	Lockheed YF-12A	83
Boeing B-17F "Flying Fortress"	39	Lockheed "Vega"	25
Boeing B-29 "Superfortress"	56	Martin MB-2	18
Boeing B-47E	66	Martin PBM-3C "Mariner"	48
Boeing B-52 "Stratofortress"	69	McDonnell F-4B "Phantom II"	77
Boeing F4B-4	32	McDonnell Douglas F-15A "Eagle"	93
Boeing P-26A	31	Morane Saulnier Type N	6
Cessna Model 421	87	Navy-Curtiss NC-4	17
Cierva autogiro	20	Nieuport XVII C.1	9
Consolidated B-24D "Liberator"	49	North American B-25H "Mitchell"	51
Consolidated PBV-5A "Catalina"	37	North American F-86F "Sabre"	65
Convair B-36D	62	North American F-100D "Super Sabre"	70
Convair B-58A "Hustler"	74	North American P-51B "Mustang"	52
Convair F-106A "Delta Dart"	75	North American X-15	79
Curtiss JN-4D "Jenny"	12	Piper J-3 "Cub"	44
Curtiss P-6E "Hawk"	30	Piper "Cherokee 140"	80
Curtiss P-36A	38	Pitcairn PA-5 "Mailwing"	24
Curtiss P-40B	46	Republic P-47D "Thunderbolt"	53
Curtiss PW-8	19	Royal Aircraft Factory R.E.8	8
De Havilland DH-4	13	Ryan NYP "Spirit of St. Louis"	22
Douglas A-26 "Invader"	55	Sikorsky R-4B	54
Douglas AD-1 "Skyraider"	61	Sikorsky S-55	67
Douglas DC-3	40	Sikorsky S-64	81
Douglas DC-8	78	SPAD XIII C.1	10
Douglas DC-9	86	Stearman Model 75	35
Douglas DC-10	91	Supermarine S.6B	29
Douglas SBD-5 "Dauntless"	45	Vertol CH-46A "Sky Knight"	76
Fairchild Model 24	34	Vickers F.B. 27A "Vimy"	14
Focke Achgelis Fa 61	41	Vought F4U-1 "Corsair"	50
Fokker D VII	15	Vought F-8E "Crusader"	72
Fokker Dr I	11	Vought O2U-1 "Corsair"	21
Ford 5-AT	26	Vought VE-7 "Bluebird"	16
General Dynamics F-111A	85	Wright "Flyer"	4

PROGRESS IN AIRCRAFT DESIGN SINCE 1903

The development of the aircraft from the humble Wright "Flyer" of 1903 to the magnificent machines of today must be ranked as one of the great engineering achievements of all time.

In no other type of vehicle is there less margin for error. Each curve, each shape, and each detailed part must be meticulously designed on the basis of quantitative data if the aircraft is to achieve its desired characteristics.

The startling changes in airplane design since 1903 are the results of technological advances in such fields as aerodynamics, propulsion, structures, materials, and internal systems. Private individuals, research laboratories operated by the government, universities and other organizations, as well as industrial design and engineering teams, have all been involved in bringing the airplane to its present state of perfection.

Aeronautical development comes by slow and painstaking work most of the time, interrupted occasionally by a brilliant insight or feat. Both the routine and the unusual are important to the growth of aviation. The immortal Douglas DC-3, for example, was a brilliant design concept, and its early use changed the face of air transport forever. But it could not have been the success it was, had it not been for dedicated work in research, development and flight that produced its cantilevered metal construction, its powerful and economical air-cooled engines, its snug-fitting and low-drag engine cowlings, its retractable landing gear, and its trailing-edge flaps to slow its landing speed and reduce its landing distance.

None of these significant technical advances had been developed specifically for the Douglas DC-3; all had originated on earlier aircraft. Yet in the design synthesis that produced the DC-3, all these features were combined — for the first time in a single aircraft — to produce a truly outstanding and significant contribution to aeronautics.

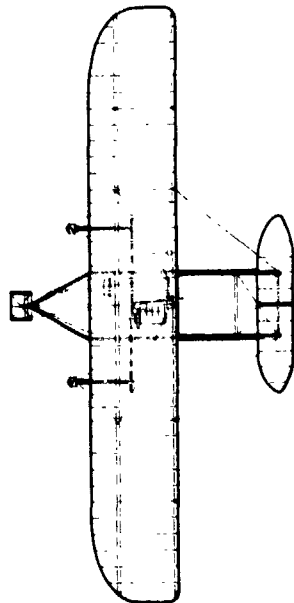

The material in this booklet is an attempt to focus attention on the widest variety of aircraft that have contributed all of the bits and pieces that have marked the course of aeronautical development in the United States. Most of the aircraft described are of American origin, because the selections for inclusion were made with the deliberate intention of charting this country's aeronautical progress.

Each of the aircraft included is of significance for one or more of the following reasons:

- **An innovation in design**, such as the variable-sweep General Dynamics F-111 series, whose wings sweep through a large angle in flight to change its shape for optimum performance.
- **An innovation in operations**, such as the Boeing 747, the first really large jet transport, designed to carry hundreds of people on transoceanic flights.
- **The best example of a specific design philosophy**, such as the Grumman F8F-1, the ultimate development of the air-cooled radial piston-engined fighter.
- **Typical of a much-used aircraft**, such as the Curtiss P-40B, which was only a fair performer, but was available in squadron strength with the Army Air Corps when America was plunged into World War II.
- **Performer of an outstanding feat**, such as Lindbergh's "Spirit of St. Louis", which completed the epochal flight across the Atlantic in 1927.

In this variety of aircraft from the past can be seen the ideas, the designs and the concepts that have formed the present, and will help to build the future, of aviation.

The progress of aircraft design technology, described in this booklet in words and pictures, is illustrated in a wall display in the Visitors' Center of the Langley Research Center, National Aeronautics and Space Administration, Hampton, Virginia.

The display presents, in miniature but highly detailed and accurate models, a broad panorama of aeronautical development. It begins with the Wright brothers' "Flyer" of 1903 and ends with the current generation of jet transports. In model form, and to a common scale, the aircraft described in this booklet take on added dimension and emphasis.

Many of the models in the Langley display were built and contributed by members of the Tidewater Branch of the International Plastic Modelers Society, an international group of scale-model enthusiasts. Certain of the models, for which no commercial kits existed, had to be fabricated completely; that work was done by several talented individuals in the Langley Research Center. A few of the models were donated specifically for the display by the manufacturers of the full-scale aircraft.

WRIGHT "FLYER"

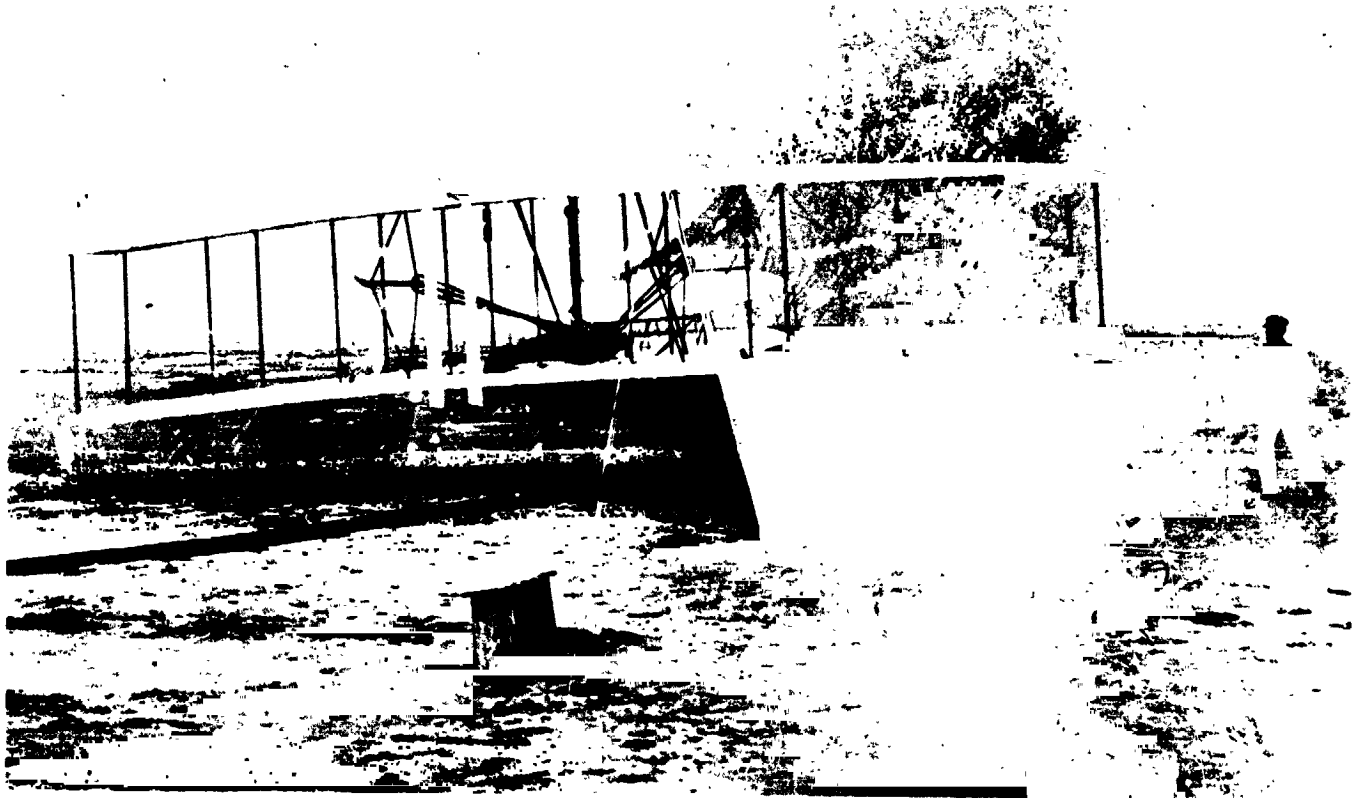

WRIGHT "FLYER": It first freed man from the grip of Earth.

This is where it all started, on a windy December day in 1903 above the sand dunes at Kitty Hawk, with Orville Wright and the fragile contraption lifting off at Kill Devil Hill and forever freeing man from the grip of Earth.

That first flight lasted 12 seconds and covered 120 feet, a little less than the wingspan of modern jet transports. But it was, as Orville Wright wrote later, "... the first in the history of the world in which a machine carrying a man had raised itself by its own power into the air in full flight, had sailed forward without reduction of speed, and had finally landed at a point as high as that from which it started."

Wilbur Wright made the second flight that day, for about 11 seconds, and covered 195 feet. On the third flight, Orville "... was proceeding along pretty well when a sudden gust ... lifted the machine up twelve to fifteen feet and turned it up sidewise in an alarming manner." He succeeded in recovering from the unusual flight condition and landed safely, having been airborne for 15 seconds over a distance of about 200 feet.

On the day's fourth flight, Wilbur maintained control for about 800 feet; but then the aircraft began to pitch and landed forcibly 852 feet from

the launching point and 59 seconds after the takeoff. While they were discussing the results of this effort, the gusty wind suddenly rolled the aircraft over, damaging it extensively. The Wrights knew that the airplane would have to be rebuilt before it could fly again. So they prepared and ate lunch, washed the dishes and walked to the weather station to send a telegram home. It read:

SUCCESS FOUR FLIGHTS THURSDAY MORNING ALL AGAINST TWENTY-ONE MILE WIND STARTED FROM LEVEL WITH ENGINE POWER ALONE AVERAGE SPEED THROUGH AIR THIRTY-ONE MILES LONGEST 59 SECONDS INFORM PRESS HOME CHRISTMAS. ORVILLE WRIGHT.

Manufacturer: Orville and Wilbur Wright, Dayton, Ohio.

Powerplant: One four-cylinder water-cooled engine built by the Wrights, developing about 12 horsepower and weighing about 170 pounds.

Dimensions: Wing span, 40 ft. 4 in.; overall length, 21 ft. 1 in.; wing area, 510 square feet.

Normal gross weight: About 750 pounds, including pilot.

First flight: December 17, 1903.

BLERIOT XI

This frail-looking monoplane, a favorite sport aircraft of its time, was destined to make aviation history and to influence military and public thinking for years to come.

Louis Blériot, very early on the morning of July 25, 1909, hobbled out to his airplane. His crutches took weight off his feet, burned in an earlier flight by a faulty exhaust shield. He made a short test flight, landed, and prepared for his epochal flight across the English Channel.

At 4:35 A.M., the Blériot XI lifted off the grassy meadow of "Les Barraques", a farm a few miles southwest of Calais, and headed out toward the Channel, climbing to an altitude under 300 feet. He later said, "During a dozen minutes I was alone, isolated, lost in the middle of a foggy sea, seeing neither a point on the horizon nor a boat. And also I had my eyes fixed on the oil distributor and the gasoline level."

Ten minutes dragged by like that and then, Blériot said, "I was happy to see a gray line detach itself from the sea. It was the English coast."

At 5:12 A.M., he landed the Blériot XI heavily in a little pasture on the gentle slope of a hill at North Fall Meadow, near Dover. The wheels and the propeller were smashed in landing, but Blériot was not hurt.

In 37 minutes he had traversed the English Channel, flying a total distance of about 24 miles. He proved that natural barriers were no longer barriers to the airplane, and he ended forever the concept of defensive retreat behind a bastion of water.

Manufacturer: Louis Blériot

Powerplant: One Anzani three-cylinder air-cooled engine developing perhaps 25 horsepower.

Dimensions: Wing span, 25 ft. 7 in.; overall length, 26 ft. 2 in.; wing area, 151 square feet.

Normal weight: About 660 pounds; empty weight, about 462 pounds.

Typical performance: Cruising speed, about 36 mph.

BLERIOT XI: An epochal Channel crossing changed strategic concepts.



MORANE-SAULNIER TYPE N

This fragile streamlined beauty was tougher than its appearance would indicate, because — as a first-line fighter during World War I — it was the first to use a machine gun firing through the propeller disc.

Consequently, it changed fighter design for all time, and influenced directly every fighter to follow.

Raymond Saulnier, who was responsible for the design, had invented a synchronizing gear for machine guns in 1914. It enabled the guns to shoot between the revolving blades of the propeller. There was one catch: The service ammunition was not of high quality, and occasionally delayed in firing just long enough to hit one of the blades. Saulnier modified his invention with a simple idea. He installed steel deflector plates on the prop blades, with the idea that they would take care of any bullet that didn't pass between the blades.

French fighter pilot Roland Garros publicized this idea in aerial combat, and achieved several victories in quick succession before being forced down on the wrong side of the lines with engine trouble. Within weeks, the Germans had copied the invention and were installing a synchronizing

gear on the Fokker monoplanes.

There are conflicting stories about that development; but they agree that the Type N was the first aircraft to fire machine guns through the prop disc.

The plane was also used by a Russian pilot, who hoped to bring down his enemies — before the day of the synchronized machine gun — by snagging them on a weighted hook which he dropped from his Morane. It worked, at least once, tearing a wing off a two-seater German Albatros.

Manufacturer: Aéroplanes Morane-Saulnier, Villacoublay, France.

Powerplant: One Le Rhone rotary air-cooled engine, rated at 110 horsepower.

Dimensions: Wing span, 27 ft. 3 in.; overall length, 22 ft.; wing area, 118 square feet.

Normal gross weight: 1,122 pounds.

Armament: One 7-mm. Hotchkiss or St-Etienne machine gun.

Typical performance: Maximum speed, 102 mph. at 6,500 feet; endurance 1½ hr.

First flight: 1913.

MORANE-SAULNIER TYPE N: A fragile beauty influenced fighter design.

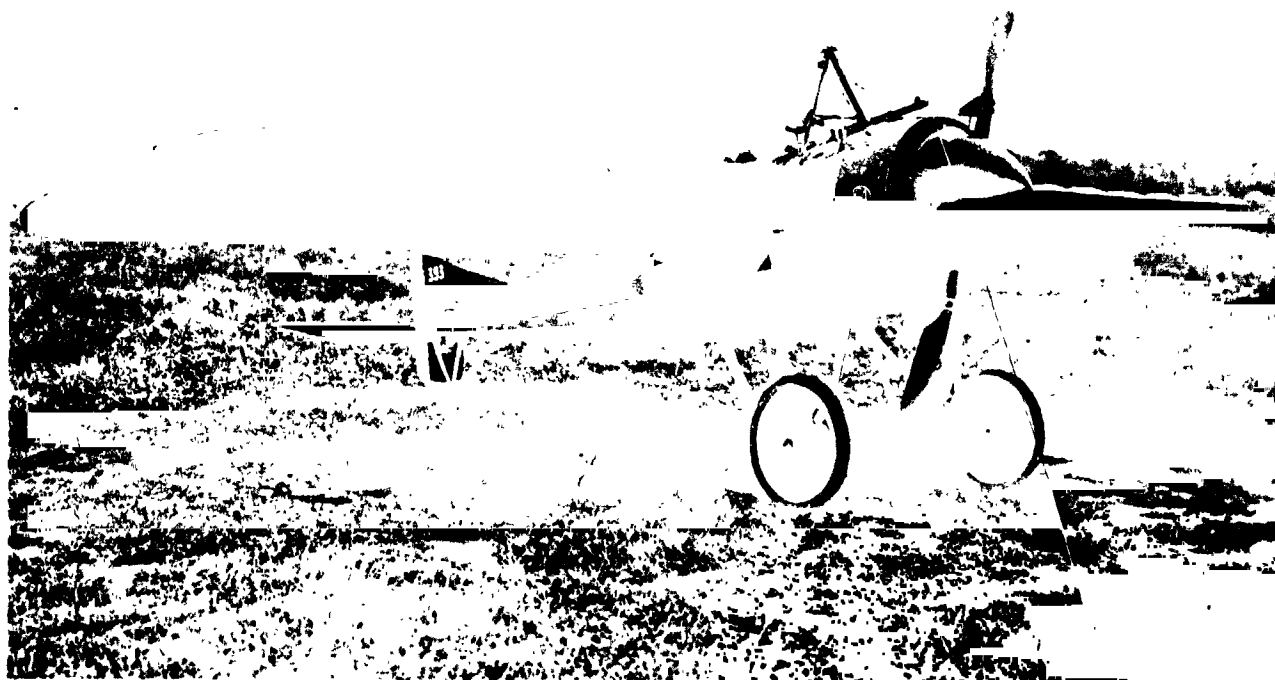

HANDLEY PAGE O/400

It was Frederick Handley Page's "bloody paralyzer", and — as the Allies first successful heavy bomber — it helped establish a concept that found later extensions in the missions of Bomber Command in World War II and of Strategic Air Command in later years.

At a time when typical bombs weighed 32 pounds, and were aimed by guess and dropped over the side of the fuselage by hand, the concept of a large bomber to drop 1,650-pound bombs on Berlin was startling.

It originated as a British Admiralty requirement and, in response, the Handley Page organization developed the huge biplane. Originally it was called the O/100, and was built in some quantity. But experience and modifications led to the O/400, basically the same airplane, but with more-powerful Rolls-Royce engines.

The first aircraft went to Royal Naval Air Service squadrons based at Dunkirk, and they promptly started a series of daylight patrols in April 1917. Later, they began nighttime raids on cross-channel ports and against German Gotha bomber bases that were being used to strike at London.

One naval squadron and several Royal Flying Corps squadrons were joined in what became the Independent Force of the Royal Air Force, and their O/400 bombers began a systematic raiding of German munitions factories in the Rhineland during the summer of 1918. In those last months of the war, the force was making night raids with formations of as many as forty O/400 aircraft.

The O/400 was one of the wartime designs selected to be built by American industry, and more than 100 were built in this country.



HANDLEY PAGE O/400:

It pioneered bomber design and mission concepts.

Manufacturer: Handley Page Ltd., Cricklewood, London, England.

Powerplant: Two Rolls-Royce "Eagle VIII" engines, each rated at 360 horsepower.

Dimensions: Wing span, 100 ft.; overall length, 62 ft. 10.25 in.; wing area, 1,648 square feet.

Normal gross weight: 13,360 pounds.

Armament: Up to 16 112-pound bombs, or eight 250-pound bombs, or three 520-pound, or three 550-pound, or one 1,650-pound.

Typical performance: Maximum speed, 97.5 mph. at sea level.

First flight: December 18, 1915 (O/100); first production deliveries, Spring 1918.

Total built: About 400 by Handley Page; 107 in America.

ROYAL AIRCRAFT FACTORY R.E.8

In retrospect, the significance of this aircraft is seen more in its concept than in the execution of that concept. It stemmed from a late 1915 requirement for an airplane that could be used for artillery spotting and reconnaissance with the British Expeditionary Force in France, and that could defend itself against enemy fighters.

Until then, airplanes used for observation had been designed to be stable in the air, to provide a steady working platform. For some reason, the R.E.8 was designed to be much less stable, apparently on the theory that it would be more maneuverable and capable of dog-fighting with an enemy.

The result was predictable. R.E.8s acquired a terrible reputation as the result of many crashes in early action at the front, and it was several years before pilots had any faith in the type as a flying

machine. By then, their confidence in it as a defensive weapon was at a low point, because it was hopelessly outclassed by the light, agile single-seat fighters the Germans were producing by the hundreds.

But with archetypical British bulldoggedness, thousands were built and pressed into service. By the end of the war, the R.E.8 had become the standard observation plane in service with corps reconnaissance squadrons.

It was called the "Harry Tate" after a British music-hall entertainer of the day, but there was nothing entertaining about the aircraft, said the pilots. They had their own, and less happy, nicknames. It was built by six other contractors, mostly automobile companies, as well as by the Royal Aircraft Factory, and among its few advantages was its relatively low cost.

ROYAL AIRCRAFT FACTORY R.E. 8: It was a good idea that turned out poorly.

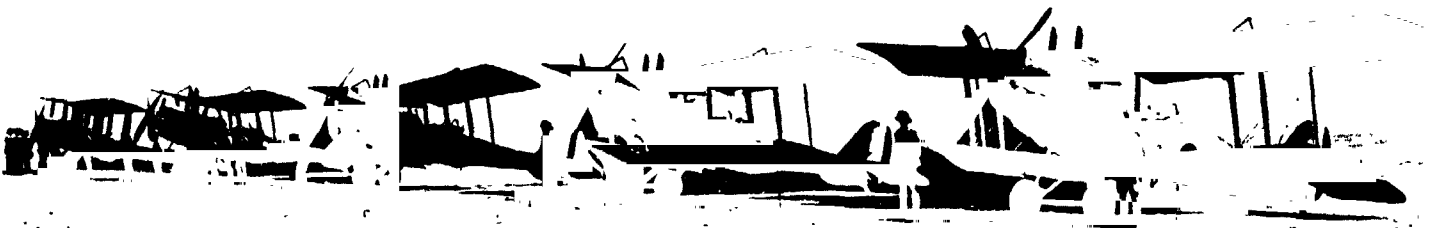

Manufacturer: Royal Aircraft Factory, Farnborough, Hants., England, and six other contractors.

Powerplant: One RAF 4a water-cooled engine rated at 150 horsepower.

Dimensions: Wing span, 42 ft. 7 in.; overall length, 27 ft. 10.5 in.; wing area, 377.5 square feet.

Normal gross weight: 2,869 pounds, including two 112-pound bombs.

Armament: One fixed and one flexible .30-caliber machine gun, plus two 112-pound bombs or the equivalent.

Typical performance: Maximum speed, 98 mph. with bombs at 6,500 feet; time to climb to 10,000 feet, 39.5 minutes; endurance, four hours.

First Flight: Mid-1916.

Total built: 4,077.

NIEUPORT XVII C.1



NIEUPORT XVII C.1: American pilots trained in this speedy fighter.

American pilots, training in France during the first World War, sharpened their aerial skills on this little fighter.

As a pursuit plane, it had achieved early fame in the capable hands of French and British aces, who preferred the light Nieuport because of its maneuverability and speed. But toward the end of the war, it was outclassed by later aircraft, and relegated to a training role for the Americans.

The distinguishing characteristic of the Nieuport XVII C.1 (17th type, pursuit, single-seat) was its sesquiplane wing arrangement, in which the lower wing seemed almost like an afterthought. It was an attempt to combine the advantages of the lower drag of the monoplane with the structural advantages of the biplane. The predecessor Nieuport fighters had featured it, and — whether or not for that reason alone — they had achieved a deserved reputation for speed, rate of climb and turning rate. The rotary engine made it a bit like trying to fly a gyroscope, in the words of one Lafayette Escadrille pilot, but they learned to compensate for that idiosyncrasy fairly soon.

Like its contemporaries, the Nieuport was built largely of wood trusswork, wire-braced and covered with fabric. Steel tubing was used in the forward fuselage and for the tail surfaces. This

lightweight structure, coupled with a fair amount of horsepower, was what gave the Nieuport its performance. It could climb to 10,000 feet in about nine minutes, a remarkable feat for that period.

The earlier Nieuport XVII models mounted a single machine gun on a tripod on the upper wing, where it fired clear of the propeller arc. That kind of mount had one advantage: The gun could be slid back and down, to fire upward into the belly of a higher target.

Some Nieuport XVII aircraft carried rockets, looking like Fourth-of-July fireworks, on their struts, fired electrically against observation balloons.

Manufacturer: Société Anonyme des Etablissements Nieuport, Issy-les-Moulineaux, France.

Powerplant: One Le Rhone 9J rotary engine rated at 110 horsepower.

Dimensions: Wing span, 27 ft. 2 in.; overall length, 18 ft. 9 in.; wing area, 161.5 square feet.

Normal gross weight: 1,232 pounds.

Armament: One .30-cal. machine gun.

Typical performance: Maximum speed, 107 mph; range, about 155 miles.

SPAD XIII C.1

"Take that, Baron von Guhlsdorf!" The twin Vickers on the SPAD's cowling chattered, spewing lead at the red Fokker . . .

Ah, the SPAD! Legendary mount of the aces who squinted, steely-eyed, through the ring sights, and shot down Fokkers by the hundreds in the pages of the pulp magazines of the Thirties.

Actually, the SPAD XIII was that good an airplane. The predominant fighter used by French, Belgian, Italian and American squadrons, it carried aces like Georges Guynemer, Eddie Rickenbacker and Frank Luke to glory.

It was a purely French production, drawn by Louis Bechereau who had designed racy monoplanes that flew off with the Gordon Bennett and Schneider Trophy contests in 1913. He worked as a designer for Armand Deperdussin, whose company was named, in characteristic French style, Société pour les Appareils Deperdussin, or SPAD for short. Deperdussin was bought out by Louis Blériot in 1914; Blériot retained the well-known initials, but renamed the company to fit: Société pour Aviation et ses Dérivés.

The SPAD XIII was the thirteenth design, and the C.1 marked it as a single-seat combat aircraft in French military shorthand.

The SPAD was a rugged, fast fighter, with an outstanding ability to dive without fear of

structural damage. It was maneuverable and had a high rate of climb, so that it could tackle any opposition in a dog-fight.

The first SPAD to see combat — the SPAD VII — and its British brother-in-arms, the S.E.5, appeared on the front in 1916. Developed models — the SPAD XIII and the S.E.5a — joined the fight in quantity early in 1918 and seized air superiority over the lines, never to lose it again during the war.

The pulp authors were right; it was truly immortal.

Manufacturer: Société pour Aviation et ses Dérivés, Paris, France, and eight other contractors.

Powerplant: One Hispano-Suiza eight-cylinder water-cooled engine rated at 220 horsepower.

Dimensions: Wing span, 26 ft. 3.75 in.; overall length, 20 ft. 4 in.; wing area, 227 square feet.

Normal gross weight: 1,807 pounds.

Armament: Two .30-cal. machine guns.

Typical performance: Maximum speed, 131.5 mph. at sea level; endurance at full throttle and 10,000 feet altitude, two hours and 30 min.

First flight: April 4, 1917.

Total built: 8,472.

SPAD XIII C.1: The legendary mount of the aces seized control of the skies.

FOKKER Dr I

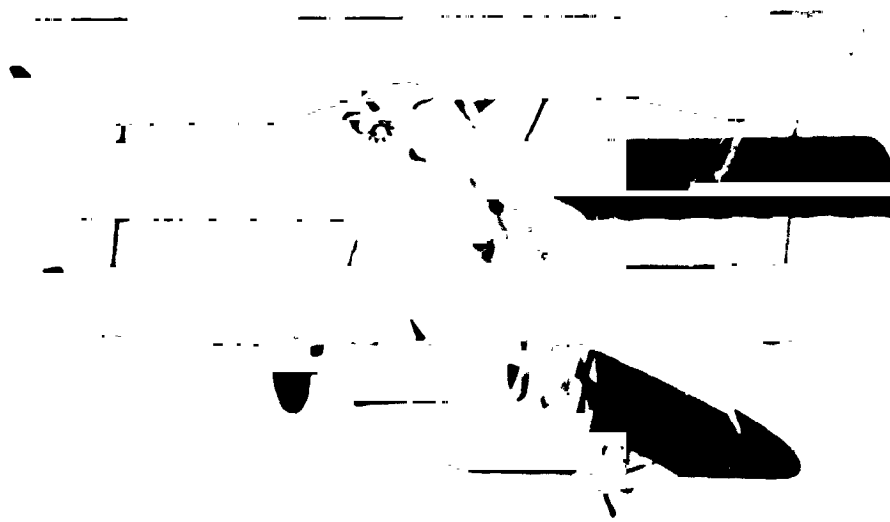

FOKKER Dr I: von Richtofen's last flight immortalized this triplane.

Manfred von Richtofen was a Baron in Prussian nobility, and on some occasions he fought in a red Fokker Dr I triplane. He shot down 19 of his total string of 80 victories while flying the triplane, and he was killed in one, most likely by ground fire from an Australian machine-gun team.

The Fokker Dr I (Dr was the abbreviation for dreidecker, or three-winged) probably was designed by Reinhold Platz, who worked on many of Fokker's advanced aircraft. It was inspired by the successes of the British Sopwith triplane on the Western front early in 1917.

The Fokker design team turned out a short-span, stubby little aircraft with a very high rate of climb and extreme maneuverability, both necessary characteristics in the personal air combat of World War I.

The powerplant was a French engine built under license in Sweden, although some Dr Is later were powered by the Oberursel, a German copy of the engine.

Few of the triplanes were red, and there are some doubts about whether von Richtofen's were all-red. They all left the factory with a gray-green streaked color scheme, fairly crying out for personal and gaudy markings. Those were applied after they reached front-line units in August 1917.

Von Richtofen flew several different triplanes. Many other first-rank German pilots chose the plane for its maneuverability, and it was very popular with them.

A series of accidents which hinted at wing structural problems grounded the Dr I temporarily in late October or early November 1917, and the type did not re-enter service until the end of the year. It continued to serve until the summer of 1918, used mostly by members of Richtofen's group.

The last Dr I was delivered in May 1918.

Manufacturer: Fokker Flugzeug-Werke GmbH.

Powerplant: One Le Rhone nine-cylinder rotary engine, rated at 110 horsepower.

Dimensions: Wing span, 23 ft. 7.38 in.; overall length, 18 ft. 11.13 in.; wing area, 202 square feet.

Normal gross weight: 1,289 pounds.

Armament: Two 7-mm. fixed Maxim/Spar-dau machine guns.

Typical performance: Maximum speed, 103 mph. at 13,120 feet altitude; duration, about 1.5 hours.

First flight: Spring/summer 1917.

Total built: 320

CURTISS JN-4D "JENNY"

It was a mediocre airplane that became a legend, a trussed and braced biplane that lumbered through the American skies for 14 years, and that survives today in a few lovingly restored examples.

The genesis of the "Jenny" was the need for a trainer plane more modern and safer than the open pusher aircraft designs in use before 1914. Curtiss developed the Models G, J and N to meet service needs, and eventually combined the best features of the J and the N into a single Model JN.

By mid-1916, the design had progressed to the fourth version in the series, the JN-4, and it in turn went through several detail changes to produce the fourth sub-model, the JN-4D.

The JN-4D became the primary trainer for most of the American pilots who served during World War I, and who stayed in the air service or joined it in the immediate post-war years. Thousands of students went through the curriculum of flight at Kelly and Brooks Fields, in Texas, and at other service schools, learning to master the "Jenny" as the first step toward solo flights in speedy SPADs and Nieuports.

At the end of the war, "Jenny" models up to the JN-4D were declared surplus to Government needs, and they went on the market at a fraction of their original cost of \$5,000. For a few hundred dollars, a flying school or an ex-service pilot could buy a "Jenny" and start barnstorming, flying passengers on scenic rides or training others to fly.

More than any other airplane, because of its cheap and easy availability, the "Jenny" opened the United States to aviation right after World War I. Citizens of remote areas saw "Jennies" at county fairs, and operating out of cow pastures, meadows, and golf courses. Their first exposure to aviation was a five-minute ride over their town, wind whipping their hair and clothes, and blurring their vision as they sought out familiar farms, buildings and landmarks.

Then in 1928, the "Jenny" was grounded because of new airworthiness regulations. It was the end of an era, now relived only by those fortunate few who own, fly, or can see the immortal lady of the skies.

Manufacturer: Curtiss Aeroplane and Motor Company.
Buffalo, New York.

Powerplant: One Curtiss OX-5, eight-cylinder V-type water-cooled engine, rated at 90 horsepower.

Dimensions: Wing span, 43 ft. 7.38 in.; overall length, 27 ft. 4 in.; wing area, 352.6 square feet.

Normal gross weight: 1,920 pounds.

Payload: Pilot and passenger.

Typical performance: Maximum speed 75 mph.; cruising speed 60 mph.

First flight: June 1917 (JN-4D)

Total built: More than 8,000 of all models of the JN series, of which 2,664 were JN-4D models.

CURTISS JN-4D: The "Jenny" brought aviation to the American public.

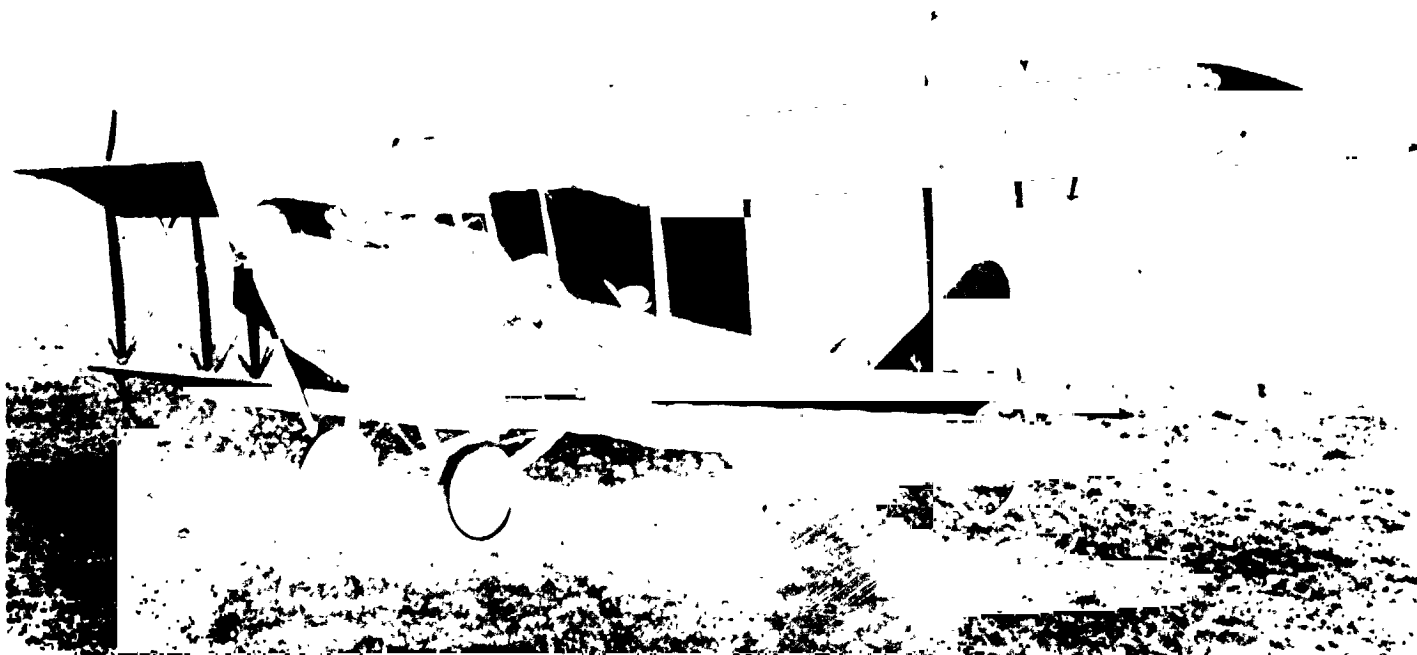

De HAVILLAND DH-4

This, the most notable high-performance day bomber of World War I, was a British design. But it was also the high point of the U. S. aviation effort in that war, and this country built more than three times the number that the British did.

They were contemptuously nicknamed "Flaming Coffins", although the U. S. losses to fire in the air totaled only eight during the war. After the war, they continued to serve with the U. S. military, and were finally phased out of active service in 1931.

The British De Havilland DH-4 was one of four designs selected to be built in the United States as its contribution to the air strength of World War I. The first British-built pattern aircraft, less its engine, arrived here in July 1917, and was rapidly fitted and tested with the Liberty 12 engine. Rechristened the "Liberty Plane", the DH-4 went into almost frenzied production aimed at getting hundreds — perhaps thousands — to the front before the war ended.

It was a magnificent effort, viewed from this later perspective. At one time, five major aircraft companies were building the plane, and — the month before the Armistice — they reached a peak production rate of nearly 1,100 "Liberty Planes" per month. The American Expeditionary Force accepted more than 1,200 airplanes before the Armistice, and of that number, 499 reached the front. Of those, 417 actually were used at the front, the only American-built aircraft to take

an active part in the war.

They were burned, in huge bonfires, immediately after the Armistice, consuming the earlier models which already had been obsolete by later and better versions in production.

The later models survived in the Air Service, and later the Air Corps, re-engined with a variety of powerplants and assigned to a wide variety of duties. They flew the mails for the Post Office from 1918 to 1927, and some continued to fly on forest patrol, a mission flown by the Air Corps with the "Liberty Planes", until 1931.

Manufacturer: Atlantic Aircraft Corp.; Boeing Airplane Company; Dayton-Wright Airplane Co.; The Fisher Body Corp.; and Standard Aircraft Corp.

Powerplant: One Liberty 12 water-cooled engine of 400 horsepower ("Liberty Plane").

Dimensions: Wing span, 42 ft. 6 in.; overall length, 30 ft. 6 in.; wing area, 440 square feet.

Normal gross weight: 4,297 pounds.

Armament: Two 230-lb. bombs under fuselage and four 112-lb. bombs under wings; one fixed .30-cal. and two flexible .30-cal. machine guns.

Typical performance: Maximum speed, 124 mph.; endurance, approximately three hours.

First flight: October 29, 1917 ("Liberty Plane"); first production deliveries, February 1918.

Total built: 4,846 (U.S. only).

De HAVILLAND DH-4: The high point of U. S. effort was a British design.

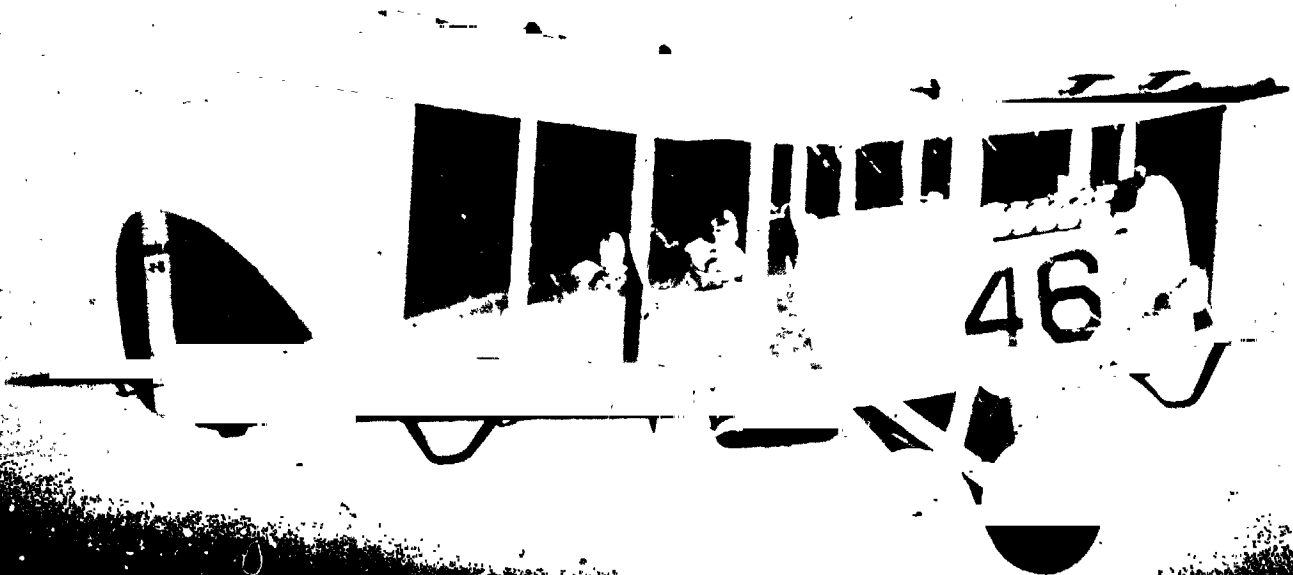

VICKERS F.B. 27A "VIMY"

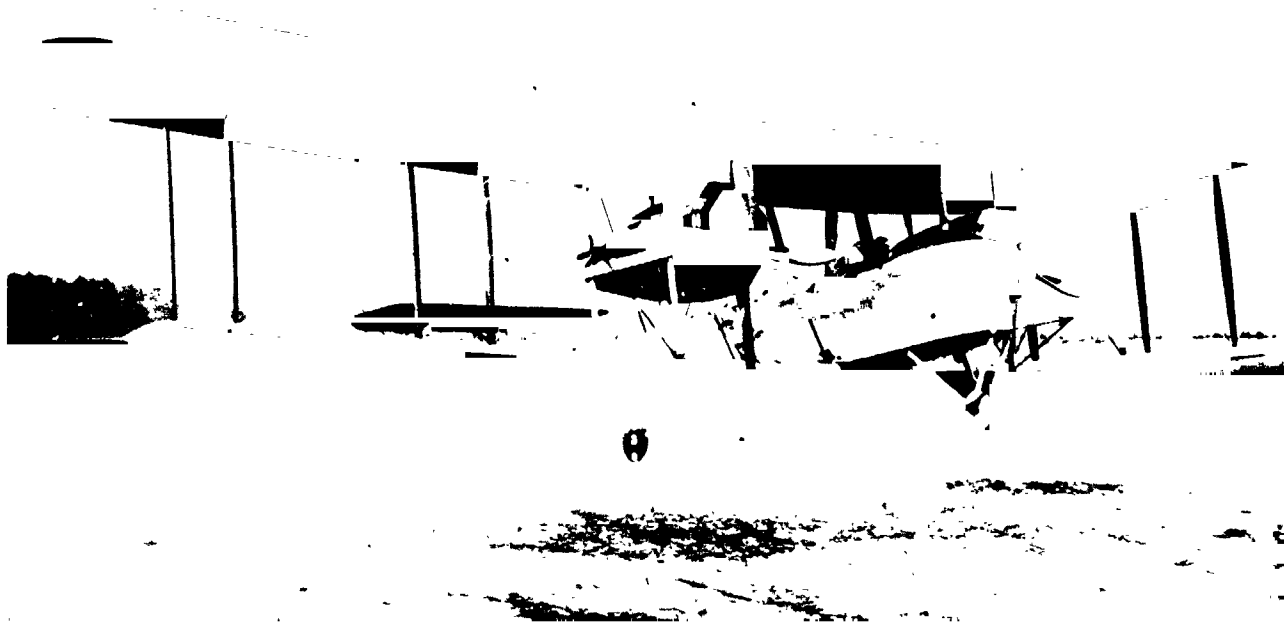

VICKERS F.B. 27A: In this "Vimy", Alcock and Brown first crossed the Atlantic non-stop.

It was designed as a bomber, but it is remembered as the airplane that carried two young Englishmen, Capt. John Alcock and Lt. Arthur Whitten Brown, across the Atlantic on the first non-stop crossing of that ocean by air.

It had been developed in 1917 to the same specification that produced the Handley Page O/400. The "Vimy" had better performance; the British military ordered 1,130 of them to be produced as quickly as possible. That order was first to be cancelled, and then reinstated in greatly reduced quantity at the end of the war, and the "Vimy" never saw service at the front. Only three had been delivered by the end of October 1918.

The 13th post-war aircraft built at the Weybridge works of Vickers was modified for the trans-Atlantic attempt. All the military equipment was removed and extra gasoline tanks were installed.

After test flights, the "Vimy" was disassembled and shipped to Newfoundland, the starting point chosen for the flight. After some problems finding a suitable field for takeoff, Alcock and Brown got the airplane assembled, rigged and tested the engines.

In the late afternoon of June 14, 1919, the big "Vimy" roared off the grassy field at St. John's, Newfoundland, and headed east over the Atlantic. They flew through the fog banks, and between fog and cloud for seven hours, seeing neither sea nor sky. At one time, the "Vimy" spun from 4,000

feet down "... very close to the water, at a dangerous angle ..." as Alcock wrote later. They ran into hail and sleet, and climbed to 11,000 feet, then flew so low that they were just skimming the surface, all with the hope of finding better visibility.

And then, after 16 hours and 27 minutes in the air, they landed in a bog near Clifden, County Galway, Ireland. This was the first crossing of the Atlantic, non-stop, by air, and it pioneered the routes that would be followed, years later, by thousands of flights across that ocean, carrying passengers and cargo at speeds five to six times faster than the "Vimy."

Manufacturer: Vickers, Ltd., Weybridge, England.

Powerplant: Two Rolls-Royce "Eagle VIII" water-cooled engines rated at 360 horsepower each.

Dimensions: Wing span, 67 ft. 2 in.; overall length, 43 ft. 6.5 in.; wing area, 1,330 square feet.

Normal gross weight: 12,500 pounds (bomber); 13,300 pounds (Alcock & Brown).

Armament: 2,476 pounds of bombs plus four .30-cal. flexible Lewis machine guns (bomber version).

Typical performance: Maximum speed, 103 mph. at sea level; range, 2,440 miles (Alcock & Brown).

First flight: November 30, 1917 (F.B.27 prototype).

Total built: 112.

FOKKER D VII

With the Fokker triplane, which it followed into production and service, the Fokker Doppeldecker VII (Double-wing, or biplane, VII) typified German air power in the last days of the first World War.

They were outstanding combat aircraft, with extremely good maneuverability. They were easily controlled, even at high altitudes, and could be pulled up to an extreme angle and held there, still under control, to slam bullets into the belly of an adversary. They could turn tightly, the low wing loading and high power of the engine whipping the biplane around in what seemed like fifty-foot circles.

Structure of the D VII was advanced for its day. Like the triplane, it had a welded steel tubing fuselage framework, covered with side panels of metal forward and a top decking of plywood aft; the rest of the fuselage covering was fabric. The wings were cantilevered, but of standard wooden construction, also fabric-covered. Tail surfaces were built of steel tubing on framework, fabric-covered.

Designed by Reinhold Platz, the Fokker D VII began to reach front-line squadrons in late April 1918. Richtofen's group of four squadrons was one of the first to be equipped with the new weapon, although their first airplanes arrived

after the Baron had been killed. Produced by both the Fokker factory and its chief competitor, the Albatroswerke, large numbers of D VII fighters were delivered during the last months of the war. By the time of the Armistice, more than 1,700 were operational.

They were specifically required by the terms of the Armistice to be handed over to the Allies, and that was generally done. But some were transported over the border into Holland by Fokker; they were used and — later — manufactured there.

Manufacturer: Fokker Flugzeug-Werke GmbH.

Powerplant: One Mercedes D III water-cooled engine, rated at 160 horsepower; later, a BMW III water-cooled engine, rated at 185 horsepower.

Dimensions: Wing span, 29 ft. 3.5 in.; overall length, 22 ft. 11.63 in.; wing area, 221.4 square feet.

Normal gross weight: 1,870 to 1,936 pounds.

Armament: Two fixed 7-mm. Maxim/Spandau machine guns.

Typical performance: Maximum speed, 117 mph. at 3,300 feet; duration, about 1½ hours.

First flight: Late 1917 or early 1918.

FOKKER D VII: Controllable and maneuverable, it was Germany's best.

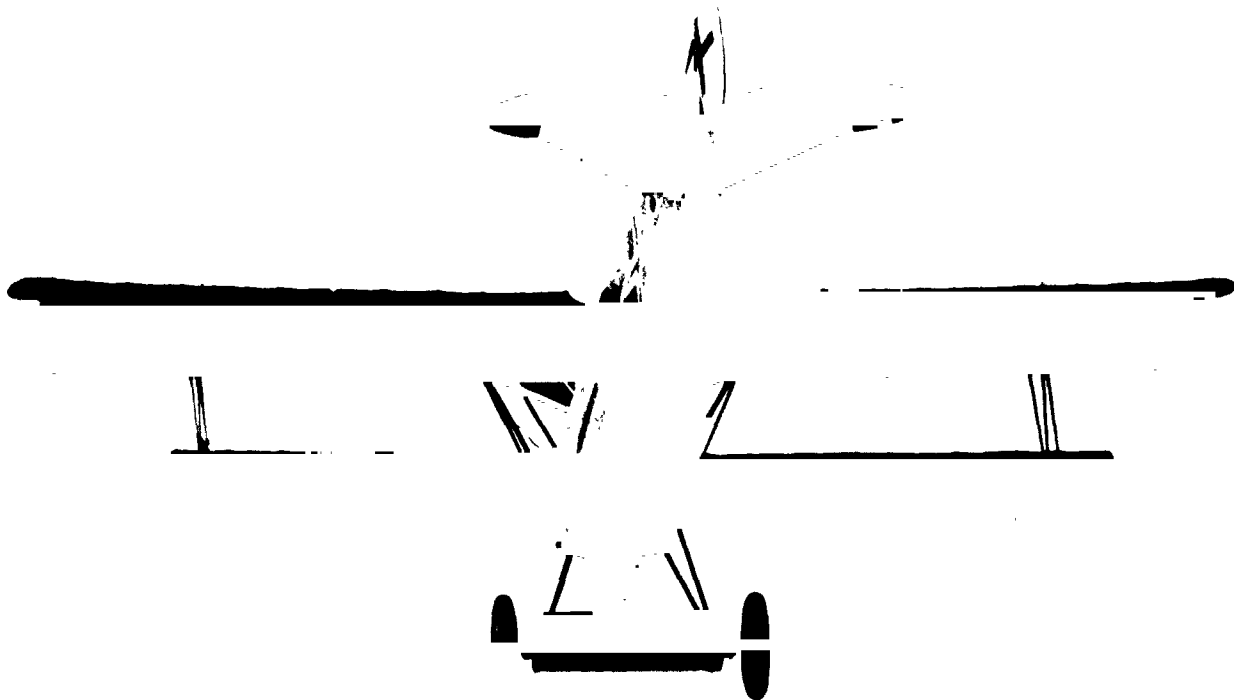

VOUGHT VE-7 "BLUEBIRD"

It was designed, built and delivered in 91 days, and its performance was so impressive in the competition for a new trainer that the Army immediately ordered 1,500 of them. But wartime economies dictated that its intended engine be used to improve an existing trainer, and the big order was cut finally to less than 20 aircraft.

One VE-7 was bought by the Navy in 1920, and it turned out to be the solution to a number of their problems. More were ordered, and additionally the Naval Aircraft Factory was put into production of the type.

The VE-7 wound up doing a variety of tasks for the Navy. It was a standard two-seat trainer; but it also served as a two-seat observation craft, a two-seat fighter, and a single-seat fighter.

It pioneered carrier operations in the U. S. fleet; it was a VE-7SF (for Scout Fighter) that made the first takeoff from an American carrier, the USS Langley, on October 17, 1922. And VE-7 models equipped the Navy's first two combat squadrons, Fighting One and Fighting Two.

It was developed into both landplane and sea-plane models, and the latter gained for the Navy and Vought much valuable experience in catapult operations from battleships and cruisers. That experience was to pay off in years to come in the designs of the enduring Vought "Corsair" and

other airplanes by other companies.

It lasted in active service as a first-line Navy fighter until about 1926. During its lifetime, it also served as a research aircraft, flying in experimental programs for the National Advisory Committee for Aeronautics, the predecessor of today's National Aeronautics and Space Administration.

The influence of the VE-7 on subsequent military, and especially Naval, aircraft was substantial.

Manufacturer: Lewis & Vought Corporation, Long Island City, New York.

Powerplant: One Wright E-2 water-cooled engine, rated at 180 horsepower.

Dimensions: Wing span, 34 ft. 4 in.; overall length, 25 ft. 5.13 in.; wing area, 284.5 square feet.

Normal gross weight: 2,100 pounds.

Crew: Pilot and observer, or student and instructor.

Typical performance: Maximum speed, 110 mph. at sea level; range, 291 miles.

First flight: Summer 1918.

Total built: 74 by Lewis & Vought, 69 by the Naval Aircraft Factory, four by Springfield Aircraft Co., and two at the Army McCook Field shops, for a total of 149.

VOUGHT VE-7: The "Bluebird" pioneered carrier operations in the U. S. fleet.

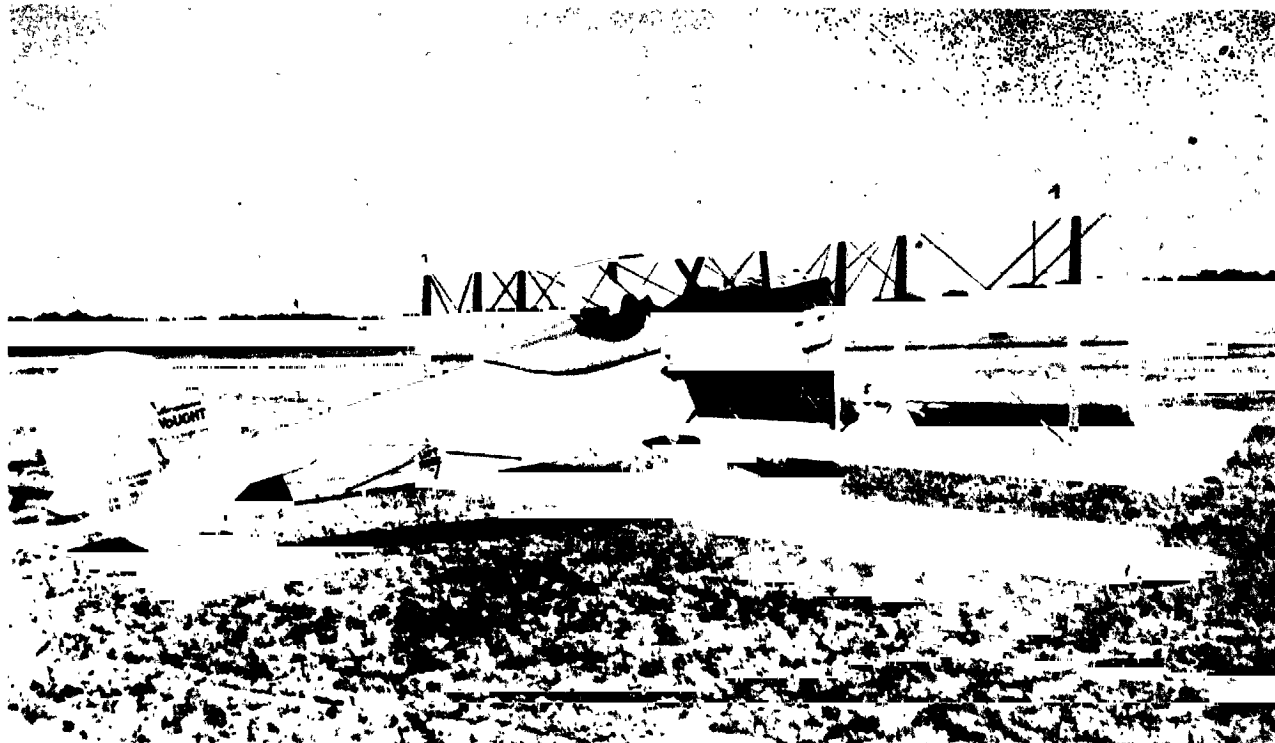

NAVY-CURTISS NC-4



NAVY-CURTISS NC-4: It made the first flight across the Atlantic.

Ten of these flying boats were built, and one — the NC-4 — became immortal for completing the first flight across the Atlantic. It was interrupted several times by incidents, and it took a total of 23 days elapsed time. But the NC-4 was the first aircraft ever to cross the Atlantic, pioneering a route that would be followed by thousands of later flights.

The boats were designed for anti-submarine duties in the first World War. The huge wings and four engines were the contemporary answer to range and endurance problems. Machine guns were fitted in turrets in the bow and amidships, for defense against the expected, occasional flying-boat fighter.

But like so many American designs of that period, the NC boats never fired their guns in anger. The NC-1, first of the line, flew hardly more than a month before the Armistice, and the first four boats were commissioned May 3, 1919.

On May 8 that year, the NC-1, NC-3 and NC-4 left Rockaway, New York, on the first leg of a flight that was aimed at crossing the Atlantic to Plymouth, England. The NC-1 and NC-3 made it to Trepassey Bay, Newfoundland, by May 10, but the NC-4, dogged by mechanical problems, did not land there until five days later. All three then departed on the first trans-Atlantic leg to the

Azores. The NC-1 was forced down at sea about 100 miles east of the islands, taxied for five hours, was taken in tow, and sank after breaking the tow line.

The NC-3 also landed short, was unable to take off and taxied for two days, finally making it into the harbor at Ponta Delgada under her own power. The NC-4 landed first at Horta, in the Azores, May 17, and then flew the short distance to Ponta Delgada on May 20. It landed at Lisbon May 27 and in Plymouth harbor on May 31.

The NC-4 was commanded on the epochal flight by Navy Lt. Cdr. Albert C. Reed; its two pilots were Coast Guard Lt. Elmer F. Stone and Navy Lt. (j.g.) Walter Hinton.

Manufacturer: Curtiss Engineering Company, Garden City, Long Island, New York.

Powerplant: Four Liberty 12-A water-cooled engines, each rated at about 400 horsepower.

Dimensions: Wing span, 126 ft.; overall length, 68 ft. 3 in.; wing area, 2,380 square feet.

Normal gross weight: 27,386 pounds.

Typical performance: Maximum speed, 85 mph.; range, about 1,470 miles.

First flight: October 4, 1918 (NC-1)

Total built: Four by Curtiss, six by the Naval Aircraft Factory.

MARTIN MB-2

"We do not sink battleships. We loop them."

This exuberant comment was scrawled on the walls of a hangar at Langley Field by a crew member of one of the Martin MB-2s that sank the German battleship "Ostfriesland" in a demonstration of air power, 60 miles off the Cape Charles, Virginia, lighthouse.

The demonstration had been arranged by the flamboyant Brigadier General William Mitchell, air power's pioneer and staunchest advocate. Among the aircraft he chose to hammer home his concepts was the Martin MB-2, then an advanced bomber with outstanding performance. It had been developed from the GMB (for Glenn Martin Bomber) of the late World War I period. Ten of these earlier bombers were built and tested in the last years of the war and the first postwar years. They flew in races and carried the mail, and served as the development base for the MB-2 design.

The MB-2 was somewhat larger, the Liberty engines were in cleaner cowlings, the landing gear was simplified, and some vertical tail area was added for better control.

These were the bombers that bounced off the grassy runway at Langley Field on July 21, 1921, headed out to sea off the Virginia Capes. Their target was one of the spoils of war: The German battleship "Ostfriesland", a heavy warship anchored to serve as a target.

In bombing attacks on previous days, Mitchell's task force had sunk a German destroyer with

300-pound bombs and a German cruiser with 600-pound bombs. On July 20, the "Ostfriesland" had been hit by smaller bombs, and had suffered damage above the waterline. But she was still afloat, to the delight of naval officers watching the tests.

Eight of the MB-2s were carrying 1,000-pound bombs and a second formation of eight was loaded with 2,000-pounders. The first formation dropped, but scored only one hit before being ordered to return to base under the complex handicapping of the tests. Later, the second formation swung in over the target and dropped six 2,000-pound bombs in succession. That did it; the "Ostfriesland" rolled, filled and sank.

Mitchell and the MB-2s had proven a basic tenet of air power.

Manufacturer: Glenn L. Martin Co., Cleveland, Ohio
Powerplant: Two Liberty 12A water-cooled engines, each rated at 410 horsepower.
Dimensions: Wing span, 74 ft. 2 in.; overall length, 42 ft. 7.75 in.; wing area, 1,121 square feet.
Normal gross weight: 13,695 pounds.
Payload: 2,000 pounds of bombs.
Typical performance: Maximum speed, 101.3 mph.; range, 400 miles with 2,000 pounds of bombs.
First flight: September 3, 1920.
Total built: 130.

MARTIN MB-2: With them, Gen. Mitchell proved a tenet of air power.



CURTISS PW-8

Based on the successful Curtiss R-6 racer, the PW-8 (for Pursuit, Water-cooled) fighter was developed privately by Curtiss. Its early flight tests at nearby Mitchel Field were impressive; among other performance advantages, it promised to be the first military aircraft able to cross the continental United States from dawn to dusk on a single day.

After two unsuccessful attempts to make that flight during 1923, and after some intervening problems with the PW-8 prototypes, the fourth production aircraft — serial 24-204 — was selected by Army Lt. Russell L. Maughan for his third try.

On June 23, 1924, having selected the day for an extra margin of sunlight, Maughan climbed into the PW-8 in the pre-dawn darkness, started the engine, taxied out and lifted off the runway at Mitchel Field at 4:30 A.M. His first stop was McCook Field, Dayton, Ohio, where he landed at 7:05 A.M. During the one-hour stay, the PW-8 wheels were changed for a larger size in the event of a forced landing in the rough country to the West.

Maughan's next stop was Rosecrans Field, St. Joseph, Missouri. It took him five tries to get airborne again because of the soft mud which covered the field from the previous day's heavy rain. The next stop was North Platte, Nebraska, and the PW-8 was checked and airborne again in 20 minutes, on the route to Cheyenne, Wyoming. After landing there and checking the airplane again, Maughan headed for Saldure, Utah, near the Great Salt Lake.

The last leg ended at Crissy Field, in San Francisco's Presidio. It grew late, the fog started to come in, and the sun was setting behind the Golden Gate while Maughan was still airborne. He finally landed at 9:48 P.M., Pacific Time, to the cheers of thousands.

There are conflicting records of that flight; in their lack of agreement, the best estimate is that Maughan was in the air approximately 18 hours on that first dawn-to-dusk trip across the United States.

Manufacturer: Curtiss Aeroplane and Motor Company, Garden City, Long Island, New York.

Powerplant: One Curtiss D-12 water-cooled engine rated at 405 horsepower.

Dimensions: Wing span, 32 ft.; overall length, 23 ft. 1 in.; wing area, 279.3 square feet.

Normal gross weight: 3,604 pounds (Maughan's airplane).

Armament: Two .30-cal. machine guns.

Typical performance: Maximum speed, 171 mph.; cruising speed, 137 mph.; range, about 950 miles.

First production deliveries: January 1923.

Total built: Three XPW-8; 25 PW-8.



CURTISS PW-8:

Lt. Maughan flew it across the U. S., dawn-to-dusk.

CIERVA AUTOGIRO

Don Juan de la Cierva, shocked by the crash of a bomber he had designed for the Spanish military, determined to find a way to keep wings from stalling. He hit upon the idea of a rotating wing, which would not stall. It would therefore contribute to the safety and the ease of flight.

His first attempt at an autogiro design, made about 1919, apparently was a failure. But he argued for a government grant, and got enough backing to develop the Cierva C.4, the first true autogiro, which he flew for the first time January 9, 1923, from a small airdrome near Madrid. It covered about 200 yards before landing. By the end of that month, a Spanish military pilot flew the craft over a four-kilometer closed course in a little over three minutes.

The autogiro, whose rotating wings are driven by air force alone, and not by an engine as is the case with the helicopter, was born. Cierva never stopped trying to improve it. His next successful attempt was the C.6A, which was built from the fuselage of a British Avro 504K trainer and other spare parts. It had a four-bladed rotor on a steel-tube pylon above the fuselage, and ailerons from a Bristol F.2B fighter were mounted on outriggers from the fuselage sides. The rotor was pre-spun by pulling on ropes wound around the rotor shaft.

This unusual conglomerate, the C.6A, first flew in May 1924, with a Spanish military pilot at the controls.

Cierva went on to develop the autogiro to a high level of design technology. During the years, he tried four-, three-, and five-bladed rotors, various types of landing gear including floats, and many different engines. It was truly a backyard inventor's kind of operation, and from that beginning came the burgeoning autogiro industry of the late 1920s and early 1930s.

Ironically, Cierva was killed in the crash of an airliner in 1936, reportedly when he was on the verge of introducing the helicopter concept as an extension of his design ideas. By then, the autogiro was on the way out of its short life, and soon after, the helicopter arrived to dominate completely the rotary-wing field.

Manufacturer: Juan de la Cierva

Powerplant: One Clerget nine-cylinder rotary air-cooled engine rated at 130 horsepower (C.6A).

Dimensions: Rotor diameter, 36 ft.; overall length, 34 ft. 4.13 in. (C.6A).

Empty weight: 1,490 pounds (C.6A).

First flight: May 1924.

CIERVA C.6A: The second of Cierva's many autogiros flew in 1924.

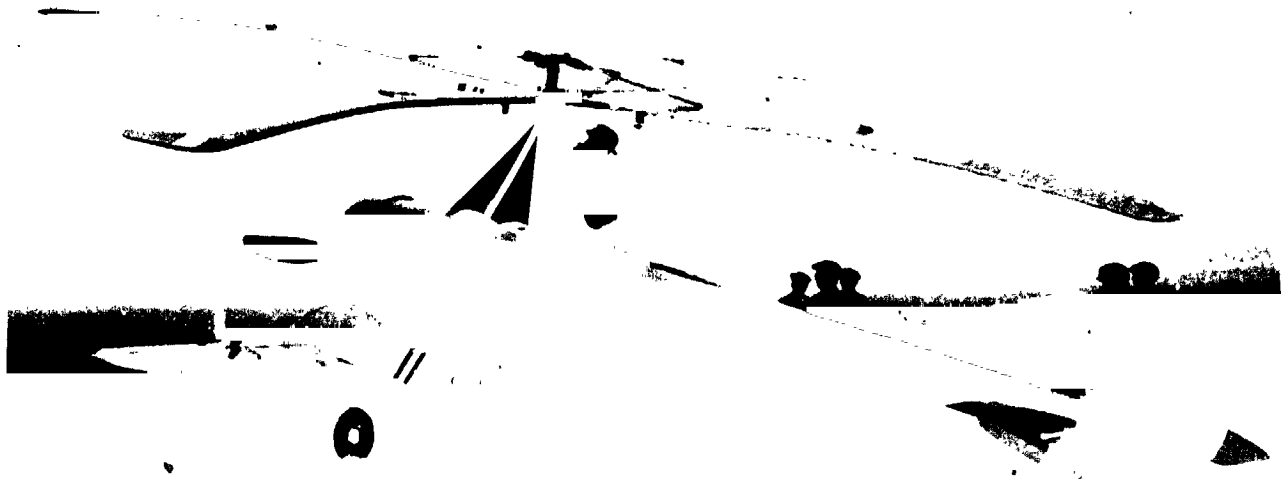



VOUGHT O2U-1: The "Corsair" contributed to shipboard aircraft design.

VOUGHT O2U-1 "CORSAIR"

In the mid-1920s, the Navy needed a replacement aircraft for its Vought UO-1 biplanes, which had been assigned to battleships and cruisers and were catapult-launched to fly observation missions. The UO-1 was basically the even-older VE-7, re-engined with a then-new radial air-cooled powerplant.

Vought designed a new biplane around a new radial engine, the Pratt & Whitney "Wasp", more reliable and lighter than its predecessor water-cooled engines of equal power. The Navy liked the design, and ordered the first two prototypes of a line that was to extend through almost ten years of production and a series of models, all named "Corsair."

The characteristic look of the plane was the slight amount of sweepback in the upper wing, placed there to cure the chronic tail-heaviness that had plagued the UO-1 and the VE-7 series.

Deliveries began in 1927, and the new aircraft were soon pressed into real combat by the U. S. Marine Corps who flew them against rebel strong points in Nicaragua during the 1927-1928 insurrection there.

The O2U-1 grew through continuing improvements, generally by increases in horsepower and weight, but the basic dimensions remained almost identical from model to model.

Vought sold nearly 200 export versions, and

received payment in a wide variety of currencies, including guano from Peru. It also was built abroad by Siam and China, and copied by the Japanese.

They lasted in U. S. service until late in 1941, but more than 100 continued to be kept around Naval air stations for service and utility aircraft.

The "Corsair" was an enduring, extensively used aircraft that generated a large export business for its developers. It made a significant contribution to the design of shipboard scout and observation aircraft.

Manufacturer: Chance Vought Corp., Long Island City, N. Y.

Powerplant: One Pratt & Whitney R1340-88 "Wasp" air-cooled radial engine rated at 450 horsepower.

Dimensions: Wing span, 34 ft. 6 in.; overall length, 24 ft. 5.25 in.; wing area, 320 square feet.

Normal gross weight: 3,635 pounds.

Armament: One fixed and two flexible .30-cal. machine guns.

Typical performance: Maximum speed, 150 mph.; range, 608 miles.

First flight: November 1926.

Total built: About 800 of all types, including 188 for export sales.

RYAN NYP "SPIRIT OF ST. LOUIS"

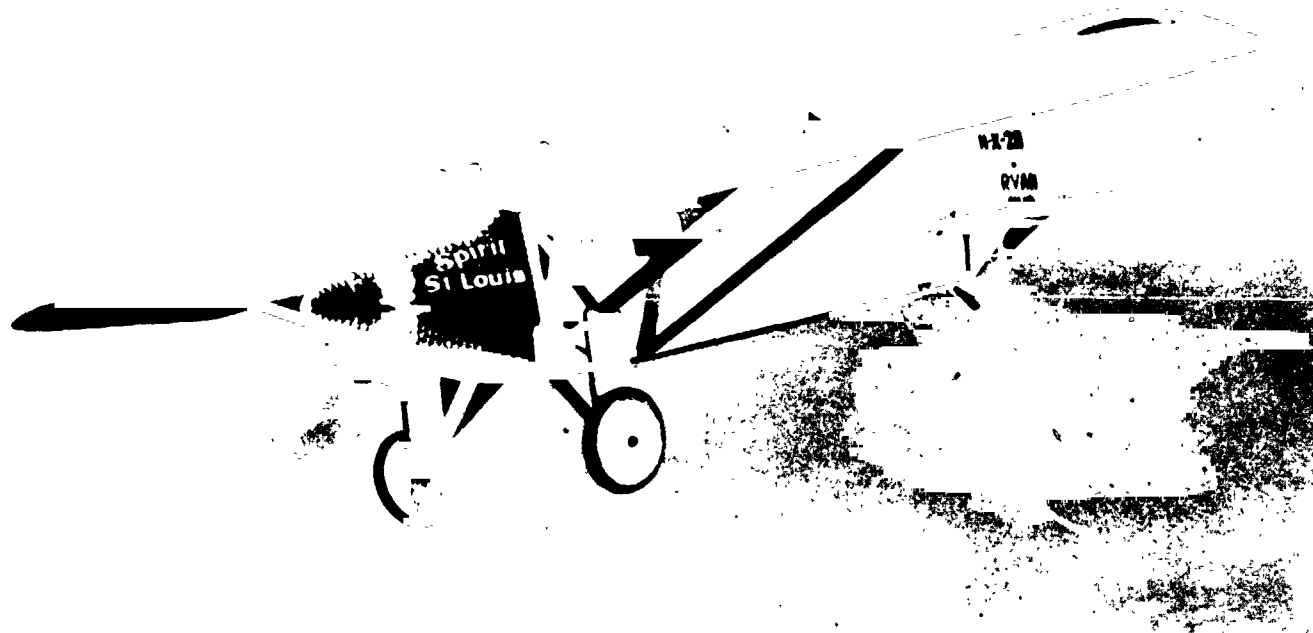

RYAN NYP: Lindbergh's solo flight won new support for aviation.

CAN YOU CONSTRUCT WHIRLWIND ENGINE PLANE CAPABLE FLYING NONSTOP BETWEEN NEW YORK AND PARIS STOP IF SO PLEASE STATE COST AND DELIVERY DATE.

The telegram went from Anglum, Missouri, to Ryan Airlines of San Diego, California, and it was the first step that led to the construction of the Ryan NYP, the airplane that carried Charles A. Lindbergh across the Atlantic and into immortality.

Ryan wired back that it would cost \$6,000 without engine and instruments, and would take three months; Lindbergh replied with a request for quicker delivery and some specifications. Back came figures for the fuel capacity, cruising speed, wing and power loadings, and a promise of a two-month delivery.

Lindbergh visited Ryan, discussed the problem, and wired his backers that he believed Ryan capable of building the plane with the performance he needed. The price with a Wright "Whirlwind" and instruments would be \$10,580, and delivery was guaranteed within 60 days.

He made the first test flight just 60 days after the design had started, and from there on, the story should be a familiar one. Lindbergh and the "Spirit of St. Louis" lifted off the bumpy sod of

Roosevelt Field, Long Island, at 7:52 in the morning of May 20, 1927, and headed out over the forbidding Atlantic.

After flying for 33 hours and 30 minutes, he landed at Le Bourget aerodrome near Paris, at 10:22 P.M. local time on May 21. The plane was mobbed by the cheering crowd, and Lindbergh was spirited away to recover from the long flight.

It was the first solo crossing of the Atlantic. It gave a tremendous stimulus to aviation, and created a new era of public interest in aviation and the exploits of airmen and aircraft.

Manufacturer: Ryan Airlines, Inc., San Diego, Calif.

Powerplant: One Wright "Whirlwind" J-5C radial air-cooled engine rated at 220 horsepower.

Dimensions: Wing span, 46 ft.; overall length, 27 ft. 8 in.; wing area, 319 square feet.

Normal gross weight: 5,250 pounds.

Useful load: 2,985 pounds.

Typical performance: Maximum speed, 124 mph.; cruising speed, 97 mph. with full load; still-air range, 4,110 miles.

First flight: April 28, 1927.

Total built: One.

BOEING 40B: Some of its passengers carried the mail on their laps.



BOEING MODEL 40B

Passengers sometimes had to hold the mail sacks on their laps within the cramped cabin of this vintage mail and passenger plane, but the glamor of being among the country's first airline passengers made up for the inconvenience.

It was the Boeing Model 40 that first made transcontinental air travel practical, if not comfortable. Developed to a Government requirement for a mail plane, the original Model 40 first flew July 7, 1925. Its wings and tail were wood structure; the fuselage mixed a wood shell construction with steel tubing framework. It was redesigned two years later when Boeing Air Transport decided to bid for the San Francisco to Chicago mail route. The redesigned fuselage structure, now entirely of welded-steel tubing, enclosed two passengers and the mail. The pilot, of course, sat in an open cockpit.

The Model 40A was the second U. S. airplane design to qualify for an Approved Type Certificate, a new standard for commercial aircraft promulgated by the Department of Commerce.

The Model 40B aircraft were all re-engined 40As. With the new engine, the 40B was so changed by the extra power that it was necessary

to go through a complete test and analysis for a new type certificate.

They sold at the factory for \$24,500, and were delivered primarily to Boeing Air Transport. Some of the B models were sold to other airlines. A further development, the Model 40B-4, carried four passengers. The Model 40C, actually an earlier model than the 40B, was basically a 40A modified to carry four passengers.

Manufacturer: Boeing Airplane Company, Seattle, Wash.

Powerplant: One Pratt & Whitney "Hornet" rated at 525 horsepower.

Dimensions: Wing span, 44 ft. 2.23 in.; overall length, 33 ft. 2.23 in.; wing area, 547 square feet.

Normal gross weight: 6,000 pounds.

Payload: 1,200 pounds of mail plus two passengers.

Typical performance: Maximum speed, 132 mph.; cruising speed, 105 mph.; range 550 miles.

First flight: May 20, 1927 (Model 40A); first deliveries of production aircraft, June 1927 (Model 40A).

Total built: 25 Model 40A; 19 Model 40B; 39 Model 40B-4; 10 Model 40C; five Model 40H-4 (Canadian-built); one Model 40X; one Model 40Y.

PITCAIRN PA-5 "MAILWING"

Back in the 1920s, the U. S. Post Office Dept. awarded air mail routes to private contractors, who were required to carry several hundred pounds of mail between specified points. One of these awards went to a division of Pitcairn Aircraft, and the company promptly designed and built the "Mailwing" specifically to carry mail between New York and Atlanta on Contract Air Mail route 19 (C.A.M. 19).

That route covered a distance of 792 miles and included stops at seven different cities. It was typical of the CAM routes, and typical of the requirements that spawned a number of mailplane modifications. But the "Mailwing" was a different breed, and it survived to become a classic in recent years.

It was, like its contemporaries, a biplane with a large wing surface for good performance in takeoff and landing from the many rural fields that served the mail routes. It carried its 500 pounds of mail in a covered compartment right under the upper wing center section, ahead of the pilot.

The structure was typical for the day: Welded steel tubing framework for the fuselage and tail surfaces, with wooden wing spars and ribs. The whole structure was fabric-covered, and lacquered to a high gloss.

In spite of the origins of the design, it was another route operator, Texas Air Transport, that first flew the "Mailwing" in service. They began in February 1928; it was not until May that year that the first "Mailwing" flew over Pitcairn's CAM-19. Texas Air Transport owned and operated seven of the airplanes; Pitcairn had 16 in service on CAM-19. Others were operated by Colonial Air Transport, and by Clifford Ball on a Pittsburgh to Cleveland run.

The "Mailwing" also was raced and shown in exhibitions with an eye on the possible market among sport and racing pilots. Its performance was outstanding for what was essentially a freight carrier, and it won several "firsts" in speed races.

Manufacturer: Pitcairn Aircraft, Inc., Bryn Athyn, Pa.

Powerplant: One Wright J-5C "Whirlwind" air-cooled radial engine rated at 220 horsepower.

Dimensions: Wing span, 33 ft.; overall length, 21 ft. 10.5 in.; wing area, 252 square feet.

Normal gross weight: 2,810 pounds.

Payload: 500 to 600 pounds of mail.

Typical performance: Maximum speed, 130 mph.; cruising speed, 110 mph.; range, 600 miles.

First flight: Mid-1927.

PITCAIRN PA-5: Built for the purpose, it carried the mail.

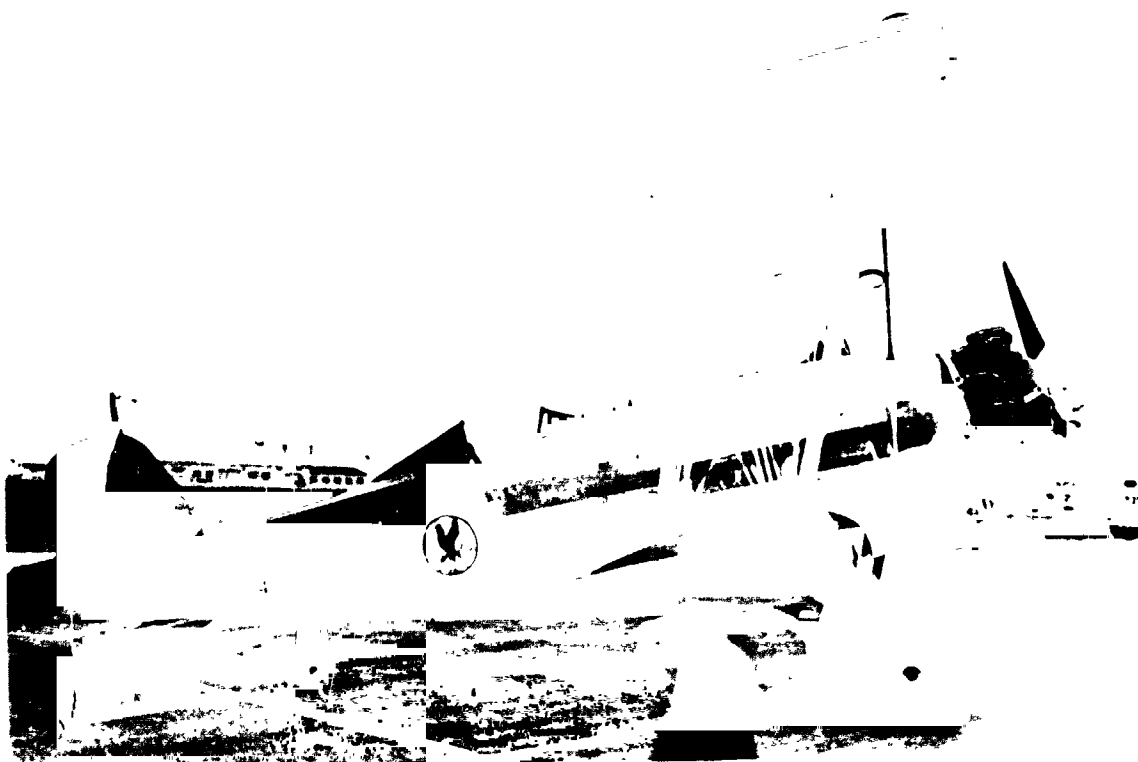

LOCKHEED "VEGA"

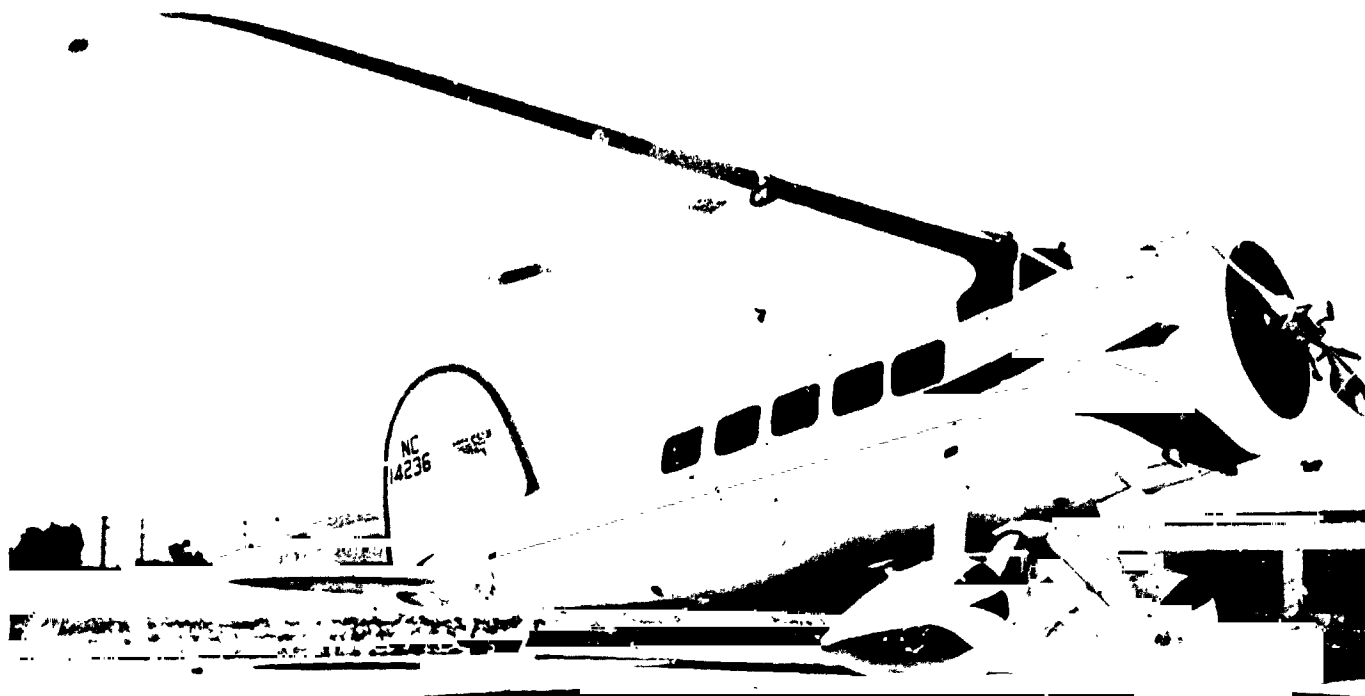

LOCKHEED "VEGA": It pioneered the style for speed and performance.

"Vega" was the name of a long line of Lockheed airplanes, used to set world records, to make historic flights, and for airline travel, military service and test flying. The first "Vega" led a generation of streamlined, cantilever-winged monoplanes, pioneering the style and lines that fairly shouted speed and performance.

And this began in 1927, when most of the aircraft companies were turning out airplanes built of wood trusswork and covered with fabric. The "Vega" was wood, also, but it was formed from a plywood shell structure, and the wing also was covered with plywood. It made a light, strong airframe, and a smooth one. Weight and drag went down; performance went up.

Part of the reason for the high performance of the "Vega" series was a new development, the NACA cowling, an engine enclosure which had been developed in the wind-tunnels of the National Advisory Committee for Aeronautics, at Langley Field, Va. A "Vega" was the first airplane to use the NACA cowling to reduce the drag of the air-cooled engine, and it became a standard feature of the type.

The "Vega" was operated by major and minor domestic and foreign scheduled airlines, by corporations for speedy executive transportation, and by such famous pilots as Amelia Earhart, Ruth Nichols, Wiley Post, Roscoe Turner, Jimmy

Mattern and Arthur Goebel.

A "Vega" was the first to fly non-stop from Los Angeles to New York, the first to fly non-stop in both directions, and the first to carry a passenger non-stop each way. It was the first to make a trans-Arctic flight, and the first to fly from and over the Antarctic. A "Vega" was the first airplane to be used to discover new land. Wiley Post, in the famed "Winnie Mae" made the first solo round-the-world flight.

The "Vega" models cost between \$13,500 and \$22,000 when they were in production. They were first-class aircraft with first-class performance, and aviation's heritage was enriched by their presence.

Manufacturer: Lockheed Aircraft Corp., Los Angeles, Calif.

Powerplant: One Wright "Whirlwind" J-5C air-cooled radial engine rated at 200 horsepower.

Dimensions: Wing span, 41 ft.; overall length, 27 ft. 6 in.; wing area, 275 square feet.

Normal gross weight: 2,900 to 3,470 pounds.

Typical performance: Maximum speed, 135 mph. to 185 mph.; normal range, 700 to 1,000 miles.

First flight: July 4, 1927.

Total built: 128, all models.

FORD 5-AT

This final development of the famed "Tin Goose" was one of the family of tri-motored Ford transports that formed the backbone of the scheduled airline industry in the late 1920s and early 1930s.

The first Ford tri-motors pioneered all-metal construction in the U. S. airline industry, and new safety and dependability resulted.

The Ford was noisy and uneconomical; but it was available, and could carry a large payload of mail, and more than a dozen passengers. The mail pay made up for the operating losses. Besides, the airplane had remarkable takeoff and landing characteristics, and would today be classed as a STOL (short takeoff and landing) type.

The forerunner was the model 4-AT, designed and built in a little more than four months. The 5-AT was basically a modification that used a larger wing and replaced the Wright engines with three Pratt & Whitney engines.

The first transcontinental air-rail service was started by Transcontinental Air Transport, a forerunner company to today's TWA, on July 7, 1929. Passengers flew the route in the Fords by day and traveled in railroad sleeping cars by night. The trip took two days; the novelty lasted about one year before being replaced by all-air service, also flown by Fords.

They sold for about \$50,000 in their production heyday, and were bought by private companies for executive and business transportation as well as by airlines and the military. They continued to fly in rugged terrain long after they had been replaced everywhere else by the ubiquitous DC-3, because they required minimum runways and could make very steep approaches. Mountain mines in South America bought Fords for that very reason.

A few are on the active roster today, and one is still flying a scheduled airline service with the remarkable Island Airlines, at Port Clinton, Ohio.

Manufacturer: Ford Motor Company, Dearborn, Michigan.

Powerplant: Three Pratt & Whitney "Wasp" air-cooled radial engines each rated at 420 horsepower.

Dimensions: Wing span, 77 ft. 10 in.; overall length, 50 ft. 3 in.; wing area, 835 square feet.

Normal gross weight: 13,500 pounds.

Payload: 3,643 pounds (13 to 15 passengers, baggage and mail).

Typical performance: Maximum speed, 152.5 mph.; cruising speed, 122 mph.; range, about 560 miles.

First flight: July 21, 1928 (5-AT-1).

Total built: 86 Model 4-AT; 116 Model 5-AT.

FORD 5-AT: The "Tin Goose" once was the backbone of the airlines.

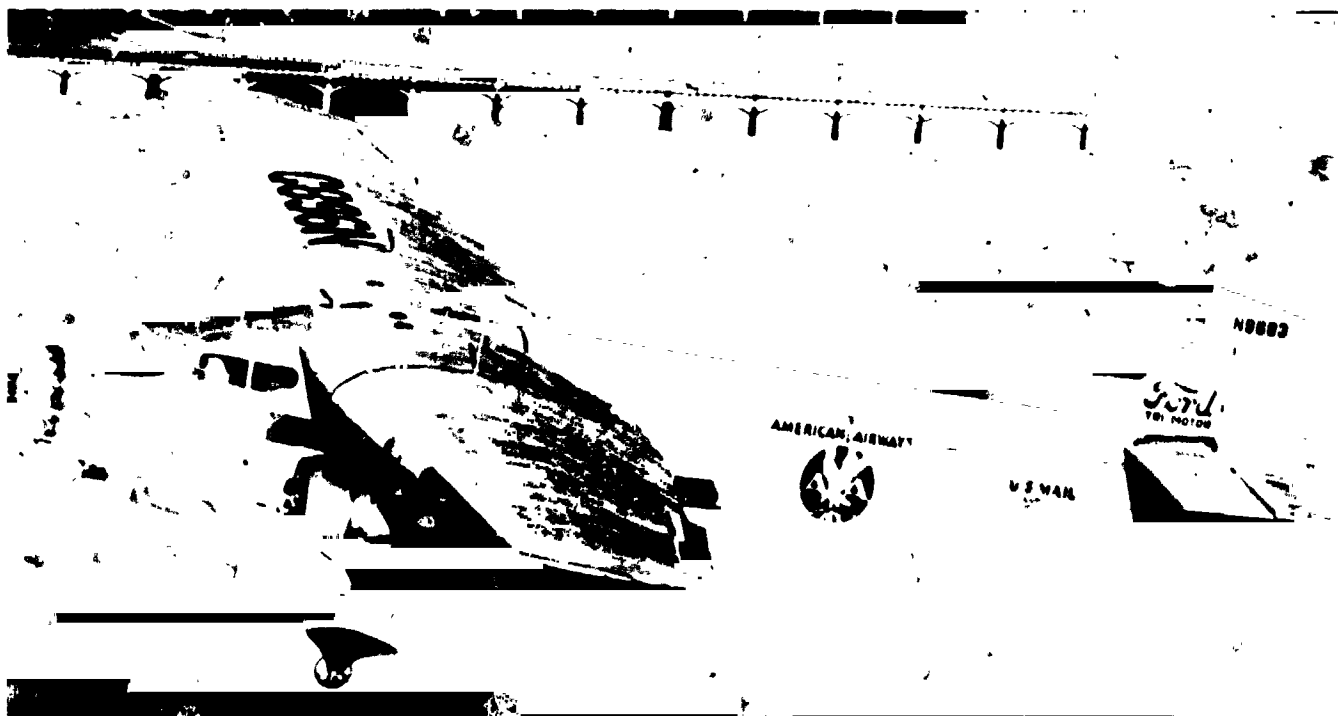

BOEING MODEL 80A-1

This multi-engined biplane transport of the late 1920s and early 1930s was designed specifically to carry passengers for profit. Boeing Air Transport, encouraged by the results of carrying passengers with the mail on the San Francisco to Chicago route, asked for a new airplane with a much larger cabin and more comfortable seating. The Boeing Model 80, designed early in 1928 and flown that same year, was the answer.

Originally built to carry twelve passengers plus a stewardess, the Model 80 was soon modified with a redesigned upper wing and higher-powered engines streamlined by the then-new NACA cowlings. These Model 80A aircraft, which cost \$75,000 each at the factory, were all later further modified to Model 80A-1 configuration by adding additional vertical tail surfaces.

Primary structure of the Model 80 series was all metal. Both steel and aluminum tubing were used in the fuselage, and the wings were built of aluminum alloy sections. With the exception of the vertical fin and a few fuselage panels, the covering was fabric.

The Model 80 introduced a new idea in air travel: The stewardess. There were other refinements, also. The cabins were finished with mahogany trim, and individual reading lamps highlighted the burnished aluminum finish of the interior hardware and the leather upholstery.

The Model 80A series had an outstanding safety record; they were dependable and stable. But they churned along at a slow speed for trans-continental air travel, and their passenger load was often limited by the higher-priority mail that had to be carried.

Manufacturer: Boeing Airplane Company, Seattle, Wash.

Powerplant: Three Pratt & Whitney "Hornet" radial air-cooled engines rated at 525 hp. each.

Dimensions: Wing span, 80 ft.; overall length, 56 ft. 6 in.; wing area, 1,220 square feet.

Normal gross weight: 17,500 pounds; empty weight, 10,735 pounds.

Payload: Eighteen passengers (Model 80A-1).

Typical performance: Maximum speed, 138 mph.; cruising speed, 125 mph.; range 460 miles.

First flight: Aug. 1928 (Model 80)

Total built: Four Model 80; 10 Model 80A (later modified to 80A-1 configuration); one Model 226 executive transport; one Model 80B (later converted to 80A-1).

BOEING 80A-1: It featured a stewardess, a new idea in air travel.

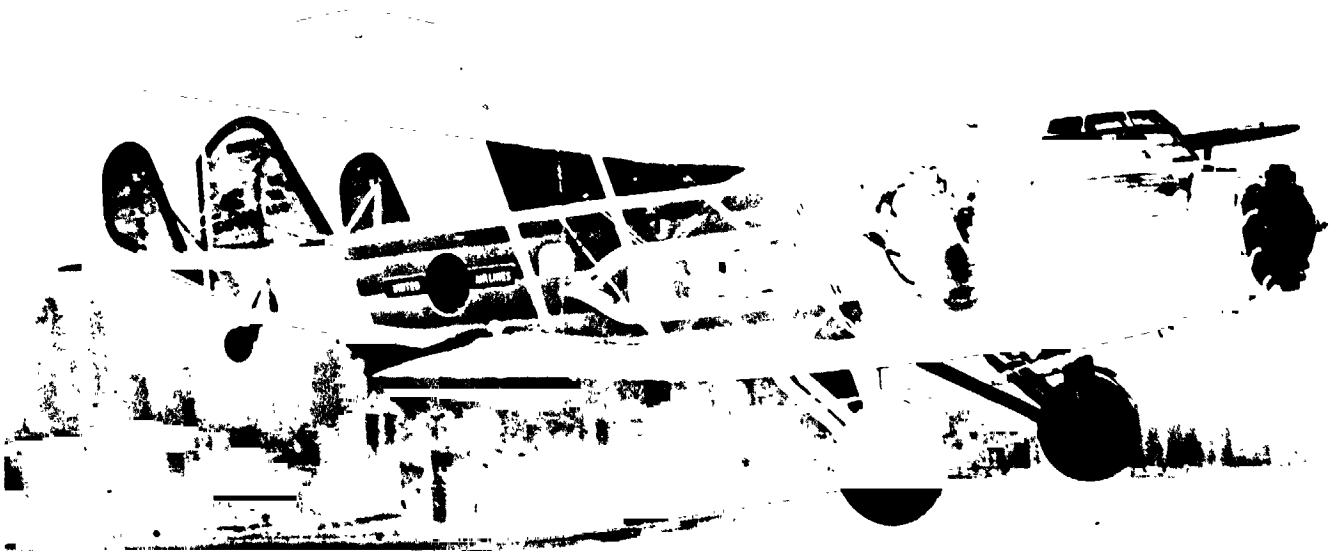

AERONCA C-2

Born in a backyard and nourished during the depression, the perky little Aeronca C-2 was America's first true, successful lightplane. It sold for \$1,495 at the factory, and 90 were bought during 1930, the first full year of production, during the depths of the depression.

It grew from the privately designed and built Roche-Dohse lightplane of 1925, and was originally powered by a homebuilt Morehouse engine delivering 29 horsepower. The design goal was simple: An economical and safe fair-weather airplane for the fun of flying.

The Roche-Dohse airplane, repainted and re-engined, became the Aeronca C-2, a single-seat lightplane with delightful flying qualities and

enough performance to meet the sportsman-pilot's requirements. The performance and economy made the C-2 a natural choice for student pilots also, and reduced the cost of flying from the then-prevalent \$30 per hour to about \$6.

The C-2 later was developed into a two-seater model, and eventually was produced in several variants with such options as floats for seaplane flying and skis for operating off snow and ice.

During the eight years the C-2 and its successors were in production, more than 500 were built, including a number under license in England. By 1937, the last year of full production, the C-2 and C-3 lightplanes held 19 official world records.

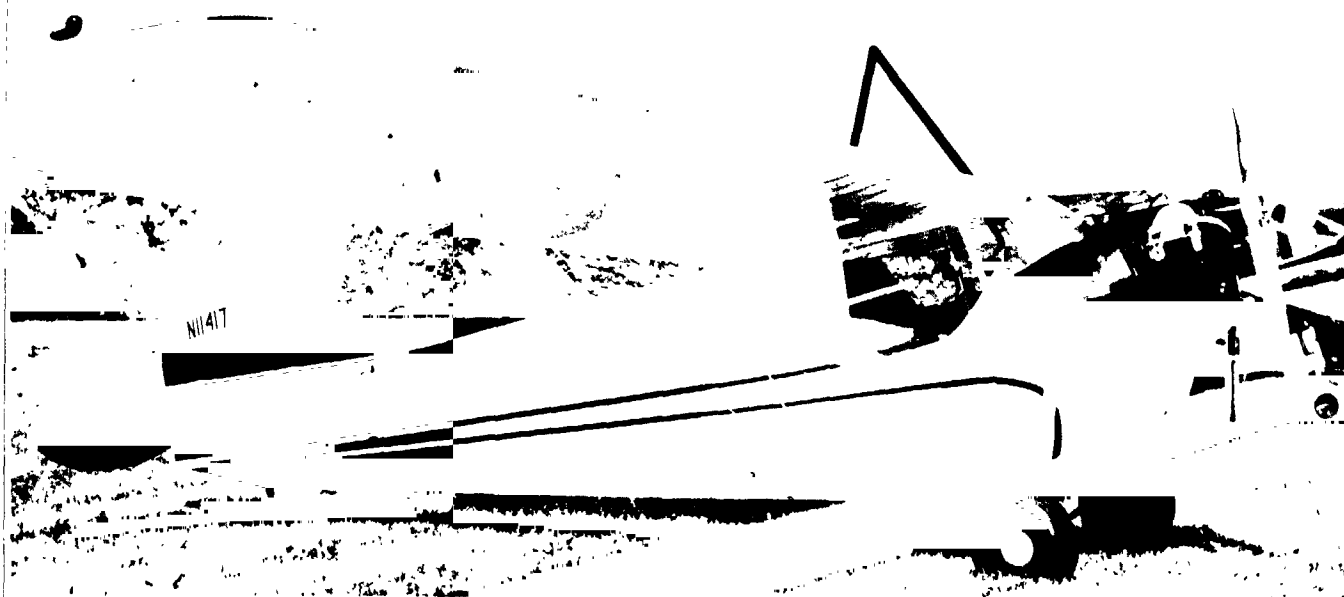

AERONCA C-2: The first successful U. S. lightplane was fun to fly.

Manufacturer: Aeronautical Corporation of America, Cincinnati, Ohio.

Powerplant: One Aeronca E-107A two-cylinder opposed air-cooled engine delivering 30 hp. at 2,500 rpm.

Dimensions: Wing span, 36 ft.; overall length, 20 ft.; wing area, 142 square feet.

Normal gross weight: 672 pounds; empty weight, 398 pounds; useful load, 274 pounds.

Typical performance: Maximum speed, 80 mph.; cruise speed, 60 mph.; range, 315 miles.

First flight: August 24, 1929.

Total built: 164 C-2 models; more than 500 of all types.

SUPERMARINE S.6B

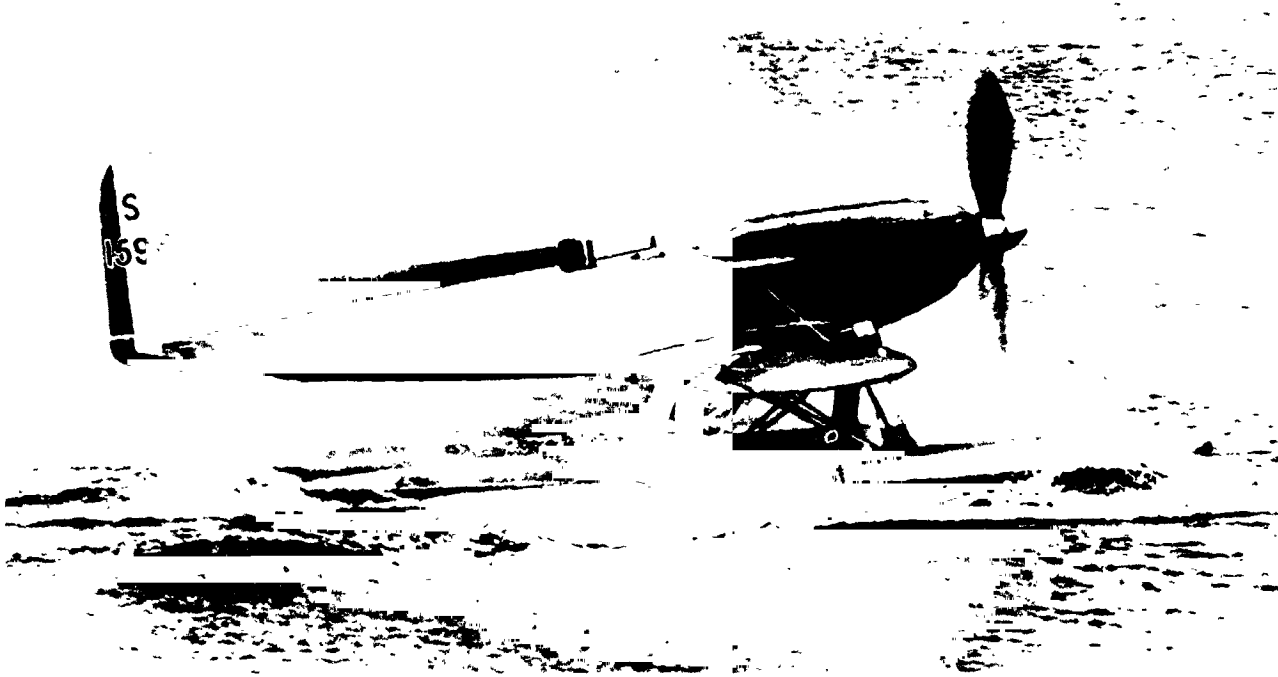

SUPERMARINE S.6B: Its speed spawned a generation of military aircraft.

This sleek seaplane racer won permanent possession of the Schneider Trophy for Great Britain in 1931, with an average speed over a triangular course of 340 mph. But behind the outward evidence of its success as a design lay the intangibles of experience gained in painstaking approaches to the realm of high-speed flight. That experience is why the Supermarine S.6B and its predecessor racing seaplanes are important aircraft.

The races originated in 1912 as a way to improve the breed of seaplanes, then far inferior to their land-based counterparts. By the time the British had scored their three wins in a row, the last in 1931, the performance of the racing seaplanes was at least 100 mph. faster than military aircraft in first-line service.

It was that high-speed performance that led directly to the new generation of military aircraft, the low-winged, cantilever monoplanes, powered by in-line, liquid-cooled Vee engines, and featuring close attention to the reduction of drag. One of that new generation was the British "Spitfire", designed by the man responsible for the S.6B: Reginald J. Mitchell.

One example of the value of this racing experience came when the earlier Supermarine

seaplanes developed control-surface flutter at high speed. It was a totally new phenomenon, one that was destined to appear time and time again in later aircraft. The British experienced the problem early, and found a way to solve it empirically.

During the depression, the British government decided it could not afford to finance the 1931 racing attempt. Lady Houston paid for the effort from her private funds, and the British took possession of the Schneider Trophy. The S.6B then was fitted with a special engine and went on to set a new world speed record of 407.5 mph.

Manufacturer: The Supermarine Aviation Works (Vickers) Ltd., Wollston, England.

Powerplant: One Rolls-Royce "R" 12-cylinder water-cooled Vee engine rated at 2,350 horsepower (S.6B).

Dimensions: Wing span, 30 ft.; overall length, 28 ft. 10 in.; wing area, 145 square feet.

Normal gross weight: 6,086 pounds.

Typical performance: Maximum speed, 407.5 mph.

First flight: June 1931.

Total built: Two S.6, later converted to S.6A configuration, plus two S.6B.

CURTISS P-6E "HAWK"

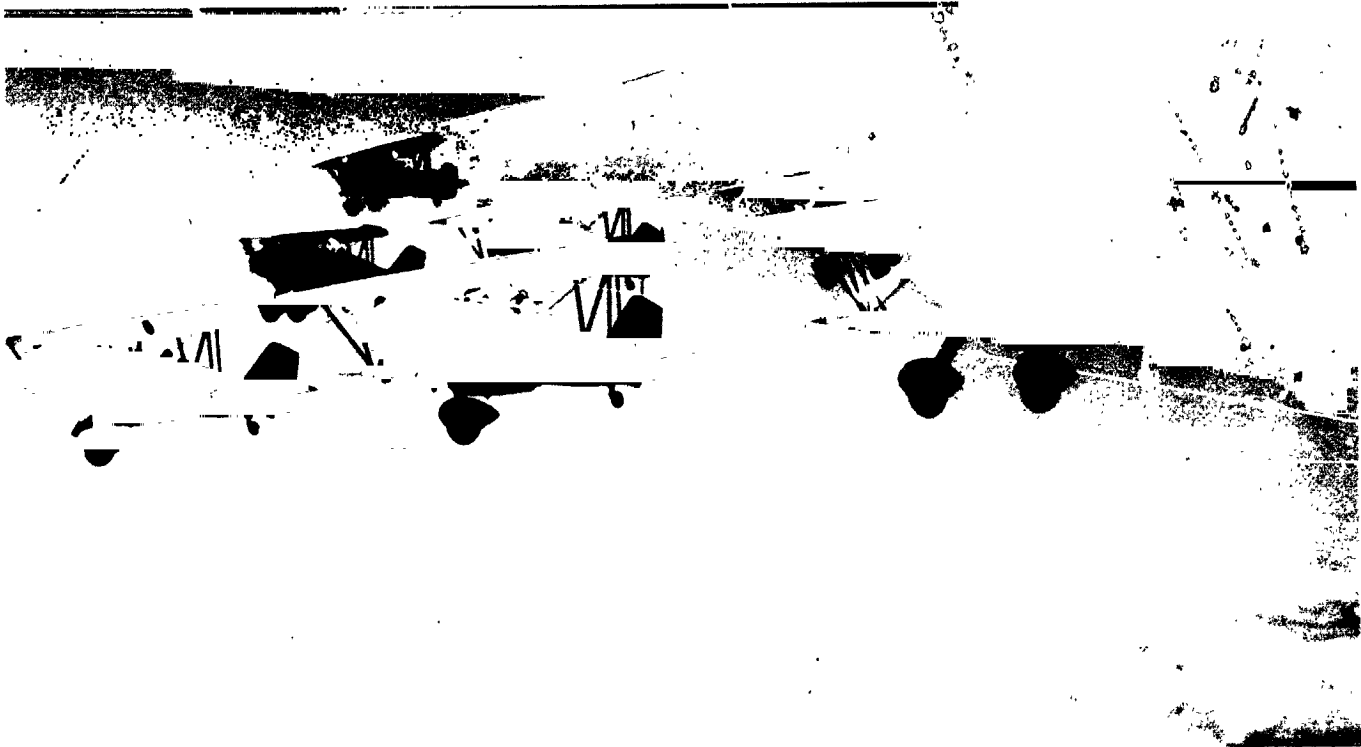

CURTISS P-6E: The "Hawk" basic design founded a line of fighters.

This elegant, classic pursuit plane shares with the Boeing P-12E/F4B-4 and Grumman F3F-3 models the pinnacle of U. S. biplane fighter design. But where the stubby Boeing and Grumman designs had air-cooled radial engines, the Curtiss "Hawk" was urged along by the 600 horses of an in-line Curtiss "Conqueror" engine, liquid-cooled by a radiator slung under the fuselage nose.

A long line of "Hawk" biplanes, traced back to the Army and Navy racers that Curtiss built between 1921 and 1925, preceded the P-6E, last major production model of the "Hawk" line. The basic "Hawk" design was a good one, and was the foundation not only for a series of Army and Navy fighters, but also for a wide variety of export models, sold all around the world. Some of these export aircraft lasted until after the second World War, a service life never envisioned by the designers.

The construction was conventional for its day. The fuselage framework was welded steel tubing, and the wings were built up of wooden spars and ribs. The entire aircraft, with the exception of a few metal panels and the cowling, was covered with doped fabric.

In addition to serving as front-line pursuit aircraft in the Army Air Corps, the P-6s did yeoman work in a series of experimental aircraft

programs that saw one or two modified to carry special "Conqueror" engines, new machine-gun arrangements, turbosuperchargers, and even radial engines by both Wright Aeronautical and Pratt & Whitney. The last P-6E was rebuilt as the XP-23 with an all-metal fuselage, new tail and nose, and a turbosupercharged engine.

They were phased out of the Air Corps by 1939, completing almost 16 years of "Hawk" service that started with the PW-8 of 1923.

Manufacturer: Curtiss Aeroplane and Motor Company, Buffalo, New York.

Powerplant: One Curtiss V1570-23 "Conqueror" liquid-cooled engine rated at 600 horsepower.

Dimensions: Wing span, 31 ft. 6 in.; overall length, 23 ft. 2 in.; wing area, 252 square feet.

Normal gross weight: 3,436 pounds (for official performance tests).

Armament: Two .30-cal. machine guns.

Typical performance: Maximum speed, 193 mph. at sea level; cruising speed, 167 mph.; range, 285 miles on internal fuel only, 572 miles with auxiliary tank.

First flight: 1931

Total built: 45 P-6E

BOEING P-26A

Fondly but never officially called the "Pea-shooter", this little fighter represented the link between old and new in military aircraft design. It retained the wire bracing, open cockpit, and fixed landing gear of the biplane age, but had the low-wing layout, the cowled engine and the all-metal construction of the new era in fighter design. It was the first monoplane fighter to go into production in the U. S. and the last of Boeing's production fighters. It featured one of the pioneering uses of wing flaps on military aircraft.

The P-26 series originated as Model 248, begun as a private venture by Boeing in September 1931. The Army agreed to provide the engines and instruments, and Boeing built three for test under the designation of XP-936. These became the XP-26 when the Army bought them soon after the testing began.

Production aircraft followed. The P-26A was the most numerous of the three production models built, and entered service with the Army Air Corps during 1934. They cost the military \$9,999, less the engine and other equipment that was furnished by the government.

These hot little airplanes landed too fast for many pilots, and the Army and Boeing developed and tested wing flaps to reduce the landing

speed. They were fitted to all the models in service and added on the production line at the factory.

These colorful anachronisms were to have a short life. The day of the cantilever wing and the retractable landing gear was almost at hand, and all the P-26s had been pulled out of front-line service by the start of World War II. But one of them, at least, was blooded in combat with a Japanese fighter; a Philippine P-26 shot down, one of the attackers during a raid on the islands early in the war.

Manufacturer: Boeing Airplane Company, Seattle, Wash.

Powerplant: One Pratt & Whitney R1340-27, radial air-cooled engine rated at 600 horsepower at 6,000-ft. altitude.

Dimensions: Wing span, 27 ft. 11.6 in.; overall length, 23 ft. 7.25 in.; wing area, 149.5 square feet.

Normal gross weight: 2,955 pounds.

Armament: One .30-cal. and one .50-cal. machine gun, or two .30-cal.; two 100-lb. or five 30-lb bombs.

Typical performance: Maximum speed, 234 mph.; cruising speed, 200 mph.; range, 635 miles.

First flight: March 20, 1932 (XP-936); January 10, 1934 (P-26A).

Total built: Three XP-936; 111 P-26A; two P-26B; 23 P-26C; 12 Model 281 export aircraft.

BOEING P-26A: A link between old and new, it pioneered wing flaps.

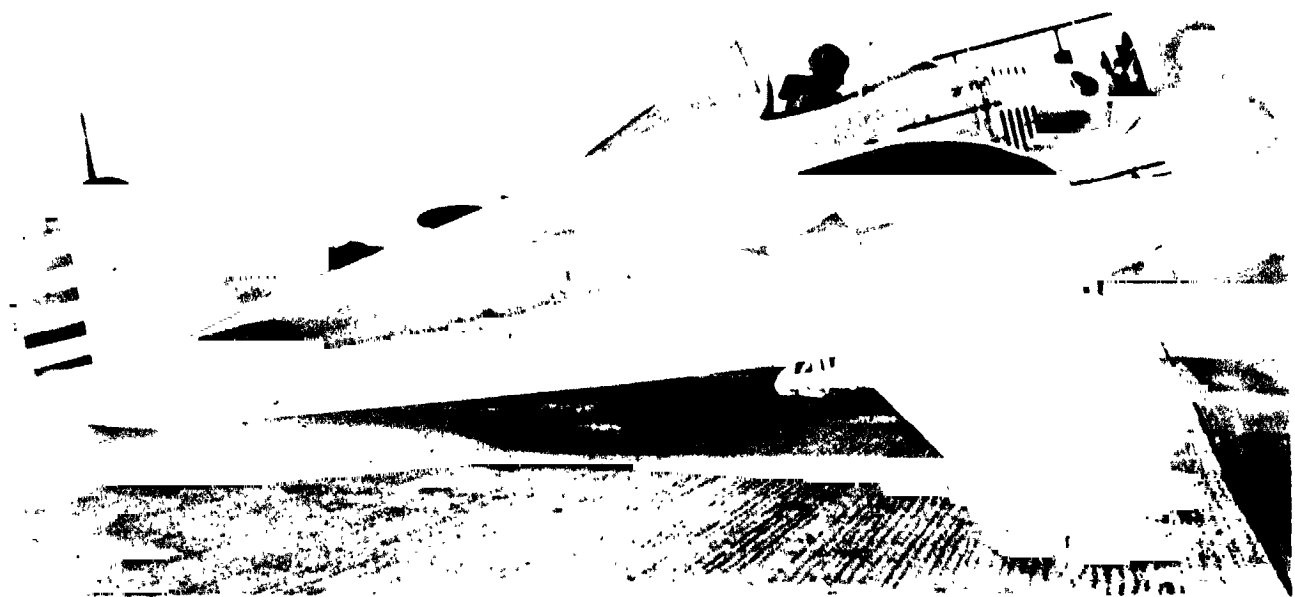

BOEING F4B-4

This fourth model of the fourth Navy fighter built by Boeing was the end of the road for the biplane fighter with fixed landing gear in U. S. naval air service.

Its rugged elegance and functional beauty are considered by many enthusiasts as a high point of the golden age of aircraft design.

The direct ancestor of the F4B-4 was the Boeing Model 15, a biplane design of 1923 which was bought by the Army to become the successful P-12 series, and by the Navy. That Navy design, the FB-1, evolved through successive models to the F4B-4, with an all-metal fuselage structure. But the wings were made from wood and covered with fabric.

They entered service with both the Navy and the Marine Corps in 1932, and served with seven different squadrons until they were outmoded by faster and more-modern aircraft in 1937. They were the last fixed landing-gear fighters in the Navy; their replacements — the Grumman F3F-2 and F3F-3 fighters — retained the biplane form, but retracted the landing gear.

After leaving front-line service, the F4B-4s

carried on in training and other utility duties, and also were used by high-ranking officers as VIP transports. Some were hastily impressed again into service for home defense in the panic that followed the attack on Pearl Harbor, and the start of U.S. involvement in World War II.

Their final role was as targets for ground gunners. Flown by radio control, the last of the Boeing biplanes were hammered out of the skies by American gunners, training for more deadly combat against tougher targets.

Manufacturer: Boeing Airplane Company, Seattle, Wash.

Powerplant: One Pratt & Whitney R1340 D air-cooled radial engine rated at 500 horsepower at 6,000 feet.

Dimensions: Wing span, 30 ft.; overall length, 20 ft. 4.69 in.; wing area, 227.5 square feet.

Normal gross weight: 3,087 pounds as fighter, 3,519 pounds as bomber.

Armament: Two .30-cal. machine guns, or one .30-cal. and one .50-cal.

First flight: July 21, 1932 (F4B-4).

Total built: 92 (F4B-4).

BOEING F4B-4: The design was a high point of aviation's golden age.

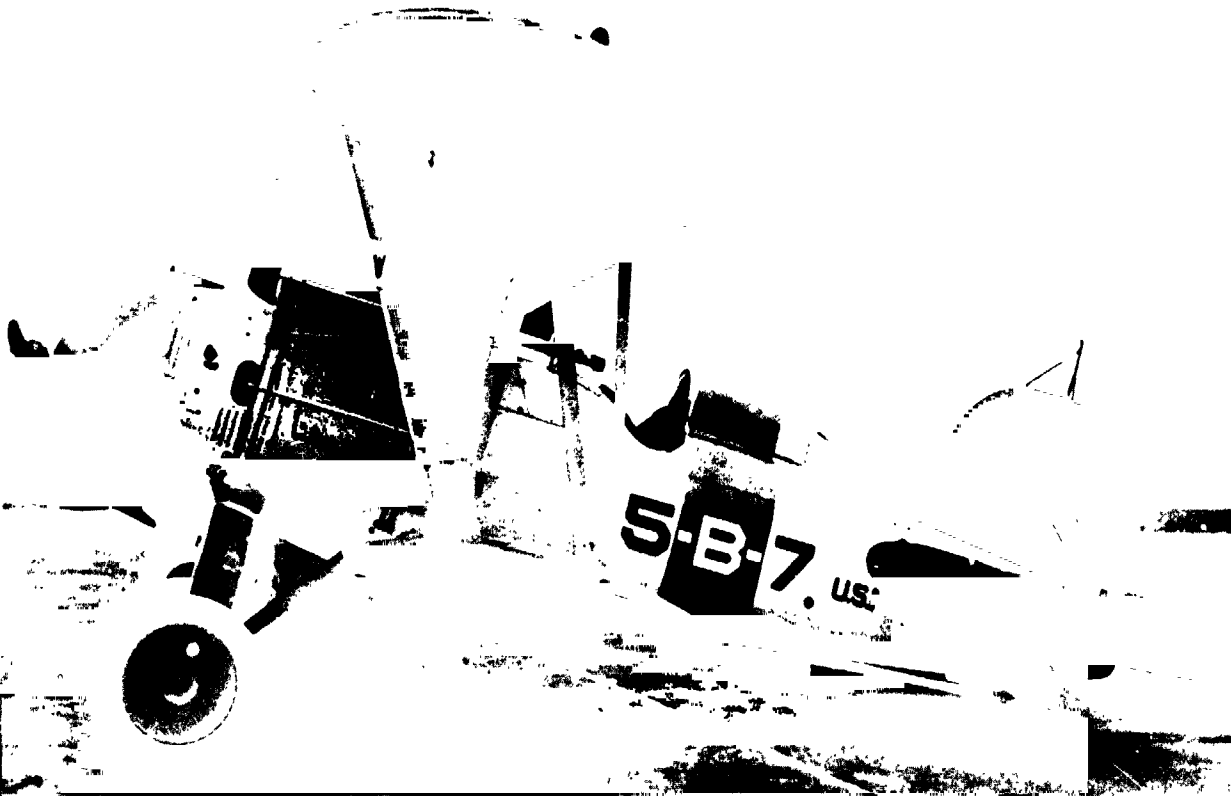



GEE-BEE R-1: Shaped like a teardrop, it was fast — and unstable.

GRANVILLE BROS. R-1 "SUPER SPORTSTER"

Flying the Gee-Bee R-1, said famed racing and test pilot Jimmy Doolittle, was "... like balancing an ice-cream cone on the tip of your finger." Doolittle flew this speedy racing monoplane in the 1932 National Air Races, at Cleveland, Ohio, racking up a speed of 294.4 mph., a new world's record for landplanes, in four runs during the Shell Speed Dashes.

Doolittle also flew the R-1 over the closed-course Thompson Trophy Race, winning with an average of 252.7 mph. for the ten-lap, ten-mile course.

The R-1, designed and built by the Granville brothers for the Springfield Air Race Association, had been test-flown only briefly before Doolittle arrived to try it. He studied it, walked around it, climbed in, and took off, never even circling the field. His goal was simple: To get that unstable winged milk-bottle to Cleveland in one piece.

The bluff shape of the R-1 came from tests in a wind-tunnel which showed the advantages of teardrop shapes, particularly if there was a big radial air-cooled engine mounted in the nose. The stubby fuselage carried low, wire-braced

wings and a fixed, streamlined landing gear completed the design. The vertical tail was almost non-existent, a feature that caused at least some of Doolittle's flying problems.

The cockpit was far aft, faired into the short fin. It barely fitted Doolittle, having been originally designed for a pilot with less-muscled shoulders.

Yet with all these disadvantages, and his unfamiliarity with the plane, Doolittle was able to win the Shell and the Thompson races in 1932. He was urged to fly the airplane later to attempt to get 300 mph. out of it, but he almost immediately announced his retirement from air racing.

Manufacturer: Granville Brothers Aircraft, Inc.,
Springfield, Mass.

Powerplant: One Pratt & Whitney R1340 "Wasp Sr."
air-cooled radial, rated at 730 horsepower.

Dimensions: Wing span, 25 ft.; overall length, 17 ft.
8 in.; wing area, 75 square feet.

Normal gross weight: 3,075 pounds.

Total built: Two (R-1 and R-2).

FAIRCHILD MODEL 24



FAIRCHILD 24: Designed for private pilots, it also aided the military.

This graceful design was in continuous production for 15 years, an unusually long life for a lightplane. It was designed to provide an enclosed cabin airplane that could be owned and operated by private pilots.

Its origins were in the persistence of Sherman Fairchild, whose interest in aerial photography had led him to form a company to build airplanes that were suitable platforms for his precise work. The first design featured an enclosed cabin for the pilot as well as the passengers, and the idea took hold.

The Model 24 started life in 1932 as a two-seat design, developed by the Kreider-Reisner Aircraft Company to Fairchild's requirements. The first production run sold at a unit price of \$3,360, a figure low enough to be within financial reach of many pilots. The success of the first model led to a continuing development of the Model 24 through a three-seat design and then a four-seat version, with more powerful engines.

Both in-line and radial engines were used in the later models, continuing to improve the performance of the little airplane.

Soon after America entered World War II, the

Model 24 was drafted for service with the Army (as the UC-61) and Navy (as the GK-1), and was sent under Lend-Lease to the British (as the RAF's "Argus"). It served as a light cargo and utility craft for the three services, and almost 1,000 were delivered to them.

It went out of production in 1947, and those that are operational today are regarded by enthusiasts as classic aircraft.

Manufacturer: Kreider-Reisner Aircraft Co.; Hagerstown, Maryland.

Powerplant: One A.C.E. Corp. "Cirrus" air-cooled in-line engine rated at 90 horsepower for takeoff (prototype); later, a Warner air-cooled radial rated at 145 horsepower; still later, Fairchild "Ranger" engines rated at 165 and 175 horsepower.

Dimensions: Wing span, 35 ft. 8 in.; overall length, 23 ft. 2 in.; wing area, 170 square feet (prototype).

Normal gross weight: 1,600 pounds (prototype).

Payload: Pilot and passenger.

Typical performance: Maximum speed, 114 mph.; cruising speed, 94 mph.; range, 350 miles. (prototype).

Total built: More than 1,000, including military types.

STEARMAN MODEL 75

It was developed as a training aircraft, designed to be rugged and forgiving, as well as easy and pleasurable to fly. It served with the U. S. Army and Navy as the standard primary trainer, and introduced a whole generation of military student pilots to the excitement of flying. It also flew in the air forces of 11 other countries, in a variety of missions from primary training to ground attack.

It was Stearman's Model 70, in its prototype form, built in a hurry toward the end of 1933 and flown probably before the year was out. After Army and Navy evaluation the following year, the Navy placed the first order for an improved Model 73 and designated it the NS-1. Production started, not to stop again until all biplane production records had been left far behind.

That early order quickly was supplemented by more, and again there was a model change. The Navy's Model 73 was followed by the Model 75, which became the standard PT-13/N2S series for the Army and Navy respectively.

Most of the models carried either the Continental or the Lycoming radial air-cooled engine in various model numbers but sharing a common 220-horsepower rating. A few were powered by the equivalent Jacobs engine, or carried special engine installations for customers who had their own reasons for selection of specific powerplants.

After the war, they became surplus and were bought by the hundreds for agricultural work. Many of these aircraft were re-engined with

surplus powerplants that more than doubled the horsepower of the trainer version. But the solid airframe of the Stearman design could handle the increased power and thrust.

Others were modified with new wings, altered fuselages, or additional protection for the crop-dusting pilot. Still others, gaudily splashed with sunbursts of color, were used in air shows around the country in routines reminiscent of the barnstormers of the 1920s.

These perky biplanes still survive, more than 40 years after the prototype first flew, working on the farm or air-show circuit, or lovingly cared for by the proud owner of an antique aircraft. The Stearman Model 75 has become a classic.

Manufacturer: Stearman Aircraft Co., Wichita, Kansas.

Powerplant: One 220-horsepower air-cooled radial, either Continental or Lycoming, with a few other installations as well.

Dimensions: Wing span, 32 ft. 2 in.; overall length, 24 ft. 0.25 in.; wing area, 297.4 square feet.

Normal gross weight: 2,717 pounds.

Crew: Two; instructor and student pilot.

Typical performance: Maximum speed, 124 mph.; cruise speed, 106 mph. at 65% power; range, 505 miles.

First flight: Late 1933.

Total built: 8,584 complete aircraft, plus spares to an equivalent of 10,346 total.

STEARMAN 75: A generation of student pilots trained on this classic.

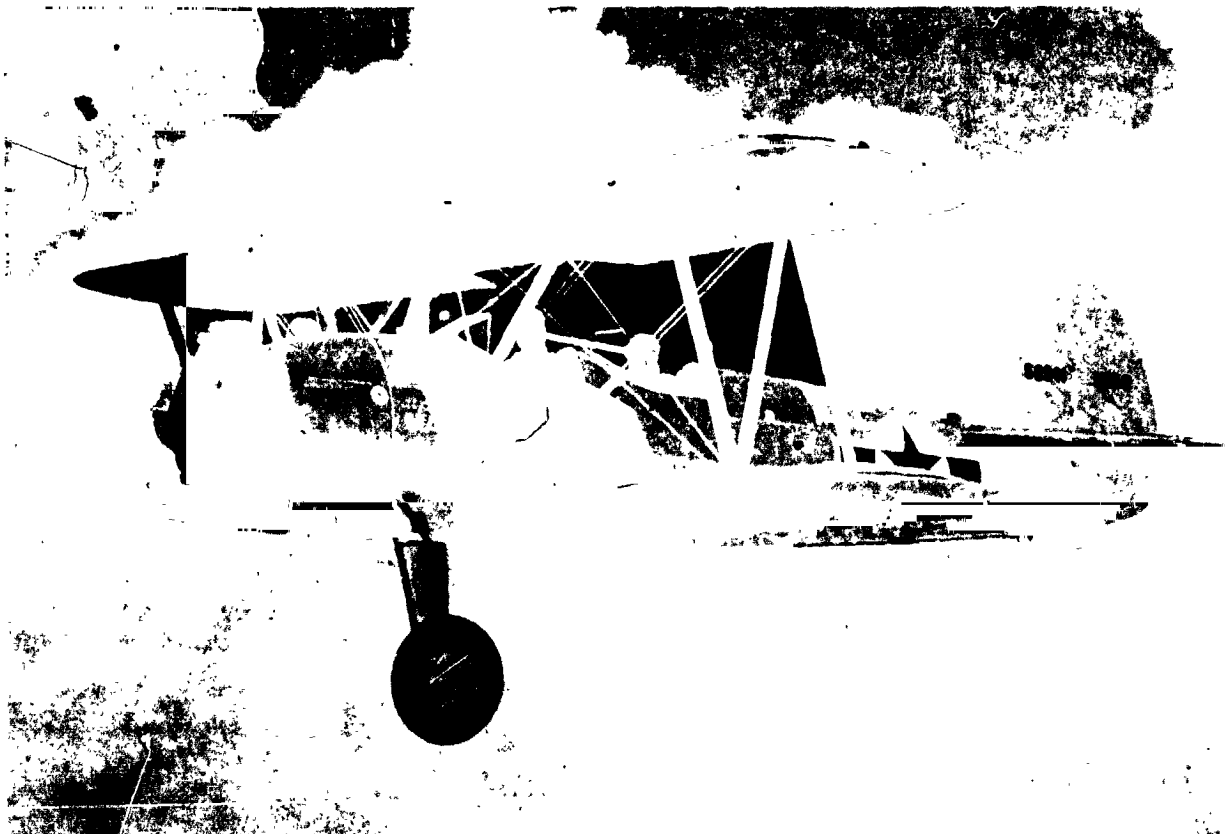

GRUMMAN F3F-2



GRUMMAN F3F-2: It was the last biplane fighter in U. S. squadrons.

This last Navy and Marine Corps biplane fighter was, in the words of the official flight test report, "... the most satisfactory single-place fighter developed for the Navy to date ..." It was the transition fighter between the fixed-landing gear biplanes typified by the Boeing F4B-4 and the new retractable landing gear monoplanes that were to become the next generation of fighters.

The F3F series was one member of a Grumman family of scouts and fighters of similar design. It started with the Grumman XFF-1, under Navy contract dated April 2, 1931, and included the production FF-1, SF-1, F2F and F3F fighters. The last production F2F-1 was modified to become the XF3F-1, featuring a somewhat longer fuselage and increased wing span. It was heavier, and therefore slower, but an engine change to increase the horsepower produced enough improvement in performance to compensate for the initial loss.

A further increase of nearly 50% in horsepower characterized the prototype XF3F-2, ordered by the Navy in July 1936. By March the next year, the Navy had settled on a production order. And, following the previous pattern, the 65th production F3F-2 was further modified to become the XF3F-3, and the progenitor of the absolutely last biplane fighter model flown by U. S. military pilots in squadron operations.

In early 1941, the bright color schemes gave way to overall gray as the Navy took on its duties in the neutrality patrol. But by then, the F3Fs were being replaced by new monoplanes like the Brewster F2A. Less than two months before the attack on Pearl Harbor, the Marines turned in their last F3F-2s, the last of the fighting biplanes.

They became trainers and station hacks, surviving into 1943, and remembered fondly by an older generation of Navy pilots who loved the stubby planes.

Manufacturer: Grumman Aircraft Engineering Corp., Bethpage, New York.

Powerplant: One Wright R1820-22 air-cooled radial engine rated at 950 horsepower.

Dimensions: Wing span, 32 ft.; overall length, 23 ft. 2 in.; wing area, 260 square feet.

Normal gross weight: 4,795 pounds (F3F-3).

Armament: Two .30-cal. fixed machine guns.

Typical performance: Maximum speed, 264 mph. at 15,200 feet; range, 980 miles.

First flight: March 22, 1935 (XF3F-1).

Total built: 164 (all models, including 81 F3F-2 aircraft).

CONSOLIDATED PBY-5A "CATALINA"

This graceful aircraft, characterized by its high parasol wing and retractable wingtip floats, was the most successful flying boat ever developed. It remained in production for ten years, continuously, and — when the totals were added — more PBYs had been built than all other flying boats combined.

It was developed in the mid-1930s as a replacement for earlier and aging Martin and Consolidated flying boats in the U.S. Navy. Begun as a patrol boat, by the time it entered production it was classified as a patrol bomber, because of an added capability to carry a load of weapons.

It entered service in the late 1930s, and its performance attracted orders from other countries as well. Australia, Canada, the Dutch East Indies and Great Britain all bought the big boats.

The PBY-5 model was the first of the series to be amphibianized by the addition of retractable landing gear, and they were in service in the Pacific when this country was plunged into World War II by the Japanese attack on Pearl Harbor, in December 1941.

It flew over the English Channel and over the Atlantic on submarine patrol and rescue missions; in the broad reaches of the Pacific it ranged over hundreds of miles in patrol, reconnaissance, rescue and anti-submarine flights. But it will be forever remembered for two major roles: First, as a rescue craft that often landed on the water

within sight of Japanese gun positions to pick up downed airmen, and second, as a bomber attacking Japanese shipping at night in the "slot", the waters between New Georgia and Santa Isabel islands on the main supply route to Guadalcanal.

It was called "Catalina" officially, but it was also lovingly called "Dumbo", after the flying elephant of the Disney cartoon. Today, a few survive, used as water bombers to fight forest fires.

Manufacturer: Consolidated Aircraft Corp., San Diego, Calif., and others.

Powerplant: Two Pratt & Whitney R1830-92 air-cooled radial engines, each rated at 1,200 horsepower for takeoff.

Dimensions: Wing span, 104 ft.; overall length, 63 ft. 10 in.; wing area, 1,400 square feet.

Normal gross weight: 35,420 pounds.

Armament: Four 1,000-pound bombs; three .30-cal. and two .50-cal. machine guns.

Typical performance: Maximum speed, 175 mph. at 7,000 feet altitude; cruising speed, 113 mph.; range, 2,350 miles.

First flight: March 28, 1935 (prototype XP3Y-1); first production deliveries, October 1936 (PBY-1).

Total built: 3,290 by Consolidated, Canadian Vickers, Boeing of Canada, and the Naval Aircraft Factory, plus possibly several hundred as the GST, built under license by the Russians.

CONSOLIDATED PBY-5A: The "Catalina" was the most successful flying boat.

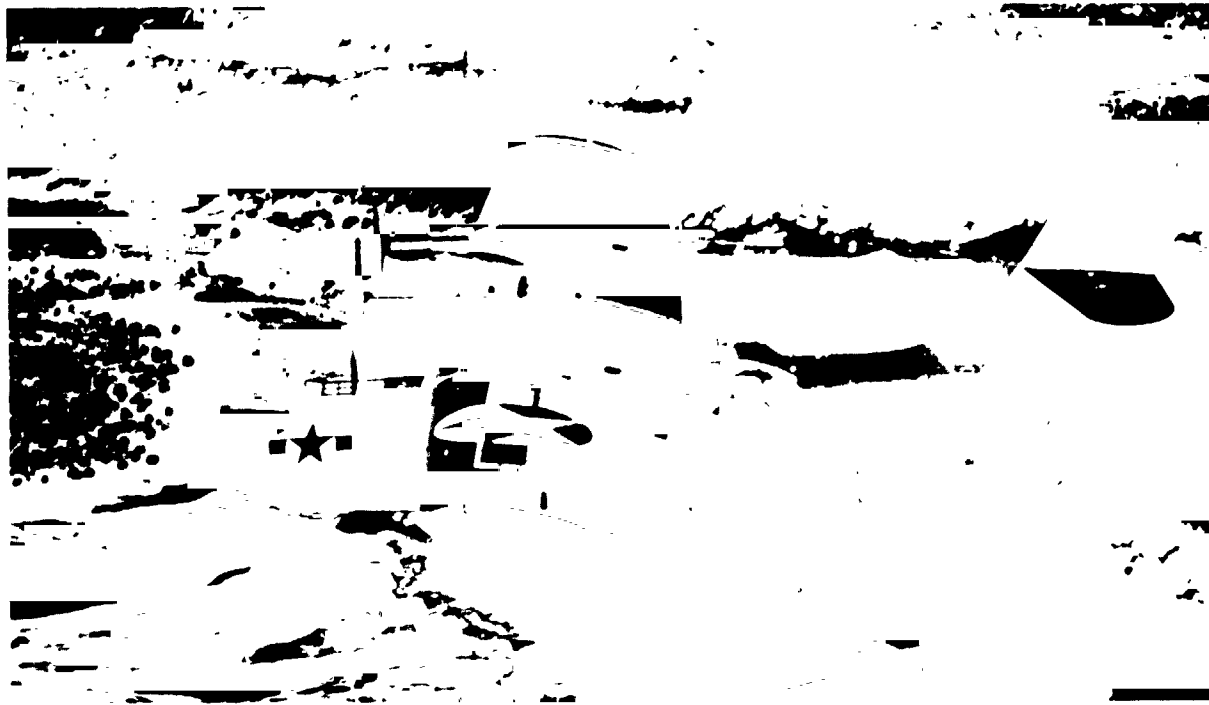

CURTISS P-36A

This stubby, radial-engined pursuit plane was the progenitor of a new breed of U. S. fighters. Replacing the Boeing P-26, the Curtiss design was conceived in 1934 for a design competition in the following year. Curtiss was the only company to meet the starting date of the competition. They lost out to the Seversky P-35, but got a consolation order for three Y1P-36 aircraft for test and evaluation.

The three planes impressed the Army, and 210 were ordered as P-36As in July 1937. First deliveries began in April 1938, and the little fighter entered squadron service with the Army Air Corps. The following month France ordered 100 export models (H75A-1), equivalent to the P-36A with only the necessary changes to match French requirements. In that service, the H75A-1s were to give the French their first victories over German aircraft in World War II. After France collapsed, some of the planes were flown to fields

in unoccupied France, or to Allied bases in North Africa or England. Some were used by the Germans for training, and some were impressed into service with the Vichy French air units and fought against the Allies.

In addition to service with the U. S. and both sides in France, the P-36 series also was bought and used by Great Britain (as the "Mohawk"), India, South Africa, Portugal, China, Finland, Holland, Peru, Argentina, and Thailand. Norway and Iran both ordered the P-36s, but neither got to use their aircraft, although some deliveries were made.

The brief glory of the P-36A came at Pearl Harbor, on December 7, 1941, when two aircraft from the 46th Pursuit Squadron at Halaiva roared off the runway to fight and down two Japanese aircraft in the first kills of the war by American air units.



CURTISS P-36A: The design formula led to a new breed of U. S. fighters.

Manufacturer: Curtiss-Wright Corp., Curtiss Airplane Division, Buffalo, New York.

Powerplant: One Pratt & Whitney R1830-13 radial air-cooled engine rated at 1,050 horsepower at 10,000 feet.

Dimensions: Wing span, 37 ft. 4 in.; overall length, 28 ft. 6 in.; wing area, 236 square feet.

Normal gross weight: 5,470 pounds.

Armament: One .30-cal. and one .50-cal. machine gun.

Typical performance: Maximum speed, 313 mph. at 10,000 feet; cruising speed, 270 mph. at 10,000 feet; range, 825 miles.

First flight: May 1935 (Model 75 prototype); first production deliveries, April 1938.

Total built: About 1,100 of all types (210 P-36A).

BOEING B-17F:
The "Flying Fortress"
had an unequalled
operational history.

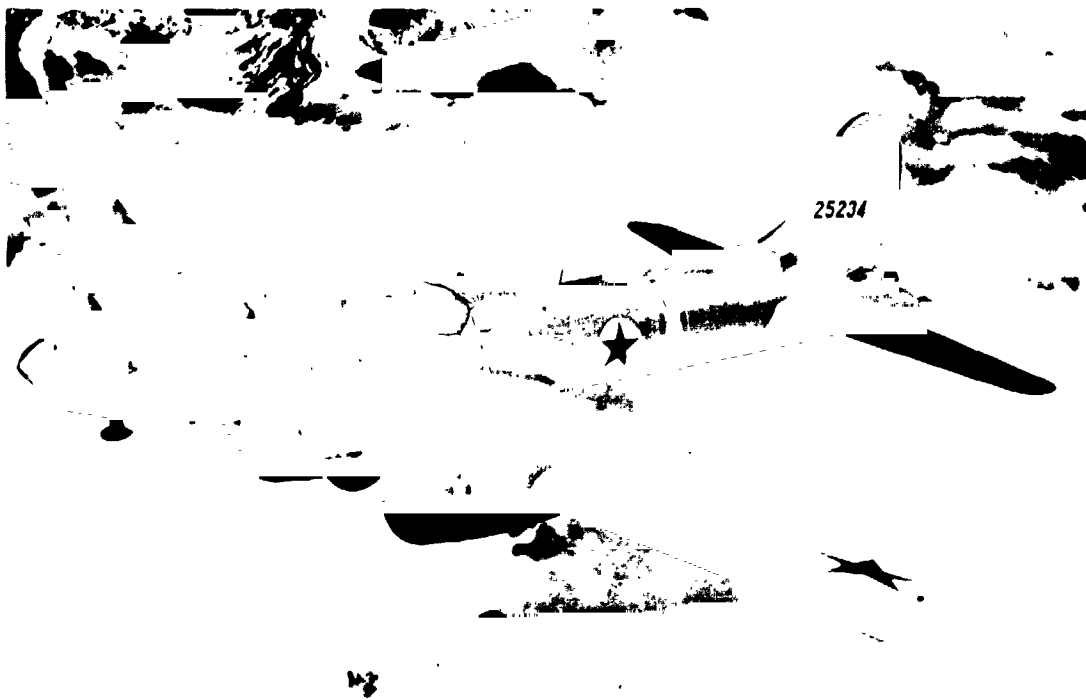

BOEING B-17F "FLYING FORTRESS"

The Boeing B-17, perhaps more than any other American aircraft, represents World War II in the air. This immortal bomber has starred in movies and television productions about those horrible and heroic days, and the sound of its engines or a glimpse of its rugged form still bring lumps to the throats of many middle-aged men.

But sentiment aside, what made the Boeing B-17 a great and significant airplane was its ability to adapt, time and time again, to operational requirements that continually got tougher. It started life as a four-engine bomber with limited defensive abilities and a fairly small — by British heavyweight standards — bomb load. It ended the war as a rugged, dependable weapon with an unequalled history of operations behind it. Its defensive power was multiplied many times over, directly in the form of more and heavier guns and more ammunition, and indirectly in the use of the "bomber box" formation that roared over the targets of industrial Europe at high altitudes, streaking long white vapor trails behind them.

The B-17s ranked high in all the ways to rate a bomber. They were predictable, handled well and lightly on the controls, took enormous amounts of battle damage and still came back. Its altitude performance was one of the strongest points. It landed slowly, due to the huge wing and the large flap area. But creature comfort was lacking. It was cold and cramped, especially for gunners in the waist and tail positions.

During the war years, B-17s were built by Lockheed's Vega subsidiary, and by Douglas Aircraft, as well as by Boeing. They served in every imaginable role, including flying gun ships, transports, rescue aircraft, drones, director aircraft, flying bombs, photo reconnaissance, cargo, and tanker versions. Captured B-17s were flown by the Germans and Japanese to develop their own defensive tactics against the type.

They served with the U. S. military until the 1950s, ending their careers as drone targets for missiles. A few privately owned still are actively flying, doing aerial survey, and fire-fighting on forest patrol.

Manufacturer: Boeing Aircraft Company, Seattle, Wash.

Powerplant: Four Wright R1820-97 air-cooled radial engines, rated at 1,200 horsepower each for takeoff.

Dimensions: Wing span, 103 ft. 9.38 in.; overall length, 73 ft. 10 in.; wing area, 1,420 square feet.

Maximum gross weight: 53,000 pounds (B-17E).

Armament: 8,000 pounds of bombs (maximum); one .30-cal. and nine .50-cal. machine guns.

Typical performance: Maximum speed, 325 mph. at 25,000 feet; cruising speed, 160 to 210 mph.; range, 2,000 mi. with 4,000 pounds of bombs.

First flight: July 28, 1935 (prototype Model 299).

Total built: 12,726 of all models.

DOUGLAS DC-3



DOUGLAS DC-3: It was the first transport to carry passengers profitably.

Known in every corner of the world, this immortal airplane was the first commercial transport to free the airlines from dependence on mail contracts for revenue. It was designed to make money for the airlines just by carrying passengers, and it did that task so well that the airlines ever since have been looking for a more-modern DC-3.

In its commercial form, it pioneered routes over terrain forbidden to earlier aircraft. It established the major airlines of the world, by giving them a solid economic foundation on which to build and expand. It helped small airlines get bigger, and new airlines to be born.

Veteran air travelers never forget the DC-3 trips they took. They climbed in the door at the rear of the cabin, bending over to avoid banging their heads. Then, turning left, they began the climb up the inclined floor of the passenger cabin, looking for seats. There were seven rows of two seats on the left side and seven single seats on the right. Meals were served in boxes, with a pillow to hold on the lap to substitute for a table.

The DC-3 cruised low enough so that the travelers could see the country they were flying over. It was also low enough so that the airplane encountered just about every bit of weather around, including sandstorms, waterspouts, and thunderstorms. But it plowed through or around them and, apart from a rough ride, there was no danger.

Developed with the active help of the airlines, the DC-3 originated as the DC-1, a synergistic synthesis of a number of technical advances:

Cantilever wings, all-metal construction, cowled radial engines, retractable landing gear, and trailing-edge flaps. DC-3s entered commercial service as 21-passenger transports and as sleeper transports for long trips. Later they served the military in every theater of war and in every kind of utility job. Most recently, they have been modified to carry gun packages for night combat in the skies of Southeast Asia; they took that task in stride.

They now have been in airline inventories since 1936, and in military service since 1942. Hundreds still survive wherever man has flown.

Manufacturer: Douglas Aircraft Co., Santa Monica, Calif.

Powerplant: Two Wright SGR1820-G2 "Cyclone" air-cooled radial engines rated at 1,000 horsepower each (Prototype); later, either Wright R1820 or Pratt & Whitney R1830 engines at 1,200 horsepower each.

Dimensions: Wing span, 95 ft.; overall length, 64 ft. 6 in.; wing area, 987 square feet.

Normal gross weight: 25,200 pounds.

Payload: 21 passengers, as designed; but later, anything that could be loaded aboard.

Typical performance: Cruising speed, 190 mph.; range, 1,500 miles.

First flight: December 17, 1935; first production delivery, June 7, 1936.

Total built: 803 commercial transports and 10,123 military versions (C-47 and others); additionally, about 2,000 built under license in Russia; about 60 in Japan.

FOCKE ACHGELIS Fa 61

This twin-rotored aircraft was the world's first controllable helicopter. Developed in secrecy by the German firm under the direction of Dr. Heinrich Focke, the Fa 61 first demonstrated the potential of the helicopter and its unique capability to hover.

Focke began the project in 1932, and the development took four years. He utilized the fuselage of a standard production Focke-Wulf Fw 44 trainer, and to it attached a trusswork of bracing struts to hold the two three-bladed rotors in a spanwise layout.

The first flights were made in 1936. By June 1937, the first (D-EBVU) of the two prototypes had established two official world records: A duration of 80 minutes, and a speed for 20 kilometers (about 12½ miles) of 76 mph. Later that year, it was flown to a new closed-circuit distance record of about 50 miles. In 1938, the first prototype was flown on a straight-line distance record flight of 143 miles. In 1939, the second prototype was flown to an altitude record of 11,243 feet.

These impressive performances were officially

witnessed and accepted by the FAI, the international body that judges all attempts at world records. The records astounded the aviation world, which was hardly aware that a helicopter was flying, let alone establishing official records.

To cap these performances, the famous woman test-pilot, Hanna Reitsch, flew the Fa 61 indoors in Berlin's Deutschlandhalle, a huge auditorium. This spectacular demonstration proved nothing, technically, but it was a masterpiece of propaganda.

There is no record of further development of the two experimental aircraft.

Manufacturer: Focke, Achgelis & Co., GmbH, Delmenhorst, Germany

Powerplant: One BMW Sh14A "Bramo" radial air-cooled engine rated at 160 horsepower.

Dimensions: Rotor disc area, 828 square feet.

Normal gross weight: 2,100 pounds.

First flight: June 26, 1936.

Total built: Two prototypes (D-EBVU and D-EKRA).

FOCKE ACHGELIS FA 61: It first demonstrated the helicopter's potential.



BEECH MODEL 18

For 32 consecutive years, the Beech Model 18 rolled off the assembly line, a world record for production longevity. The versatility and utility of this twin-engined craft — which was produced in 32 different models — have assured it of its place in aeronautical history.

It was the second design produced by the company, following on the heels of another classic aircraft, the Model 17 "staggerwing" Beech, and it was a major departure in construction. The all-metal monoplane started from Walter H. Beech's premise that a twin-engined aircraft should have a rudder behind each engine for optimum control.

That distinctive twin-tailed empennage was duplicated on more than 9,000 Model 18s during the production run. Early buyers of the plane were small Canadian airlines, who needed the combination of passenger capacity, flying qualities and economy that the Model 18 offered.

Later, military services bought 5,204 of them, and used them for everything from crew training to tactical bombers. More than 90% of the bombardiers and navigators serving with the U. S. military during World War II had their training on one model or another of the Beech 18.

In the postwar years, the Beech D18S model, a deluxe eight-place version, became business aviation's primary choice for executive trans-

portation.

Other manufacturers modified the aircraft to specific customer requirements, including conversions to tricycle landing gear. And — through the years — the basic airplane grew in weight and capability as more powerful engines were installed. But the basic structure remained the same. The last three production aircraft were delivered in November, 1969.

Currently, more than 2,000 Model 18 aircraft are registered within the United States, and an unknown number in foreign countries.

Manufacturer: Beech Aircraft Company, Wichita, Kansas.

Powerplant: Two Wright R760E-2 "Whirlwind" air-cooled radial engines rated at 320 horsepower each (Model 18A); later models also had Jacobs and Pratt & Whitney engines.

Dimensions: Wing span, 47 ft. 8 in.; overall length, 31 ft. 11 in.; wing area, 347 square feet.

Normal gross weight: 6,700 pounds (Model A); useful load, 2,758 pounds (Model A).

Typical performance: Maximum speed, 196 mph.; range, 1,200 miles.

First flight: January 15, 1937; first production aircraft delivered: June 25, 1937.

Total built: More than 9,000 of all models.

BEECH 18: It set a world record for production longevity.

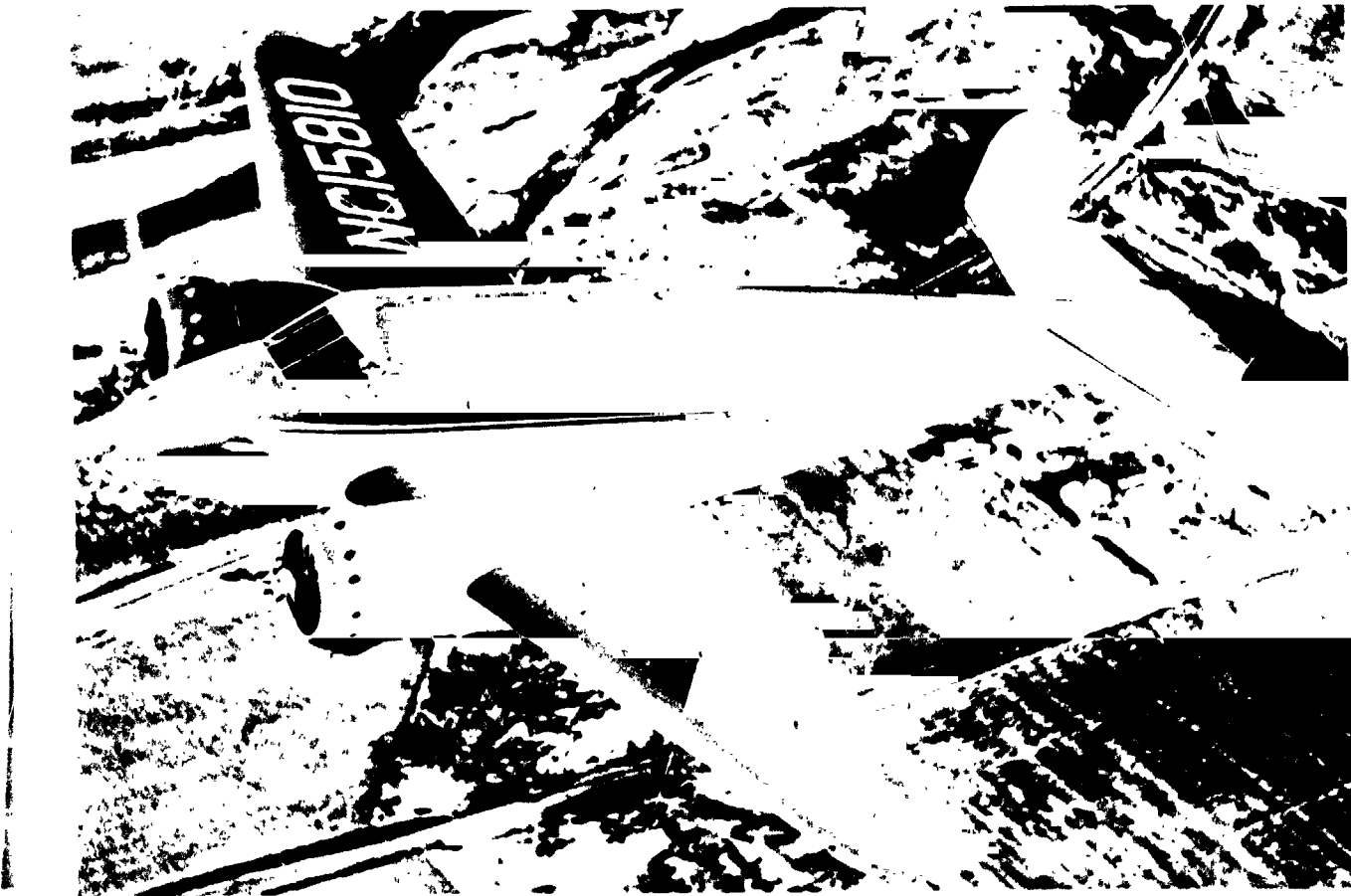

GRUMMAN F4F-3 "WILDCAT"



GRUMMAN F4F-3: The "Wildcat" was a superior weapon for skilled pilots.

First of the line of Grumman "Cats", the F4Fs held the line in the Pacific for the first two years of America's battles in World War II, fighting and clawing their way into and out of combat against outnumbering and superior aircraft.

It started as a derivation of the biplane fighters, and — as the XF4F-2 — was a loser in a competition for orders with the Brewster F2A-1. But the Navy contracted for a development with a supercharged engine, and this airplane — the XF4F-3 — had exceptional performance. Production orders followed.

They entered service one year before the attack on Pearl Harbor, and were deployed with the Navy on carriers and with the Marine Corps on island bases when the U. S. entered the war. A handful of Marine "Wildcats" defended Wake Island heroically against incredible odds, never managing to get more than three aircraft in the air at one time.

The first Navy ace of the war, Lt. E. H. O'Hare, shot down five Japanese bombers and damaged a sixth during a single mission in his "Wildcat" on February 20, 1942.

They were ordered by the French, but delivered to and operated by the British. Second source production was set up with Eastern Aircraft

Division of General Motors, and "Wildcats" poured out of both factories by the thousands.

Their kill average for the war was almost seven to one, which was an exceptional figure for an un-exceptional airplane. The "Wildcat" was inferior to its principal fighter opposition, the Japanese Zero, but its heavy armament and Grumman's "Iron Works" construction made it a superior weapon in the hands of skilled pilots.

Manufacturer: Grumman Aircraft Engineering Corp., Bethpage, New York.

Powerplant: One Wright R1820-76 air-cooled radial engine, rated at 1,200 horsepower for takeoff (F4F-3).

Dimensions: Wing span, 38 ft.; overall length, 28 ft. 9.38 in.; wing area, 260 square feet.

Normal gross weight: 7,065 pounds.

Armament: Four wing-mounted .50-cal. machine guns.

Typical performance: Maximum speed, 331 mph. at 21,300 feet altitude; range, 860 miles.

First flight: September 2, 1937 (XF4F-2 prototype); February 12, 1939 (XF4F-3); February 1940 (F4F-3 production aircraft).

Total built: 7,415 of all models, of which 285 were F4F-3s.

PIPER J-3 "CUB"

The Piper J-3 "Cub" became the Model T of aviation. It was, and is, easily the best-known lightplane of all time, and its name has become the generic term for all of them.

Built by the thousands for both civilian and military use, the J-3, its predecessors and similar successors, have been in continuous production for more than 40 years.

It started life as a simple design for a tandem-seat two-place lightplane for the private owner. After a series of ups and downs for the airplane and its producers, including a disastrous factory fire, the design evolved into the J-3 version. It featured such refinements as a tail wheel and brakes, and a starter made of rubberized shock cord, wound around a drum that could be engaged to the engine drive shaft. Most of the time the starter worked. Metal wing spars replaced the wooden ones of the earlier J-2, and the yellow paint job — to become standard for all civilian "Cubs" — was adopted.

By December 1941, one-third of all the airplanes in America, and nearly two-thirds of all the lightplanes, were Piper "Cubs."

World War II brought new orders to Piper for the J-3, painted olive drab and redesignated the L-4, for Army artillery spotting and liaison. Besides that workhorse task, the L-4s served as transports for Generals Eisenhower, Patton, Bradley, Clark and others. They landed on beachheads and back

roads, in pastures and plowed fields, and gave the ground forces a degree of communication they never had before then.

"Cubs" were armed with rockets, optimistically, perhaps. One was used to capture two enemy soldiers by landing next to them. One even was credited with downing a Messerschmitt Bf-109 that was chasing the "Cub." The L-4 could turn on a dime at low altitude; it did, and the German couldn't.

In spite of wartime heroics, it is as a civilian lightplane that the "Cub" will always be remembered. It gave wings to thousands of pilots, whose first dual and first solo were done in the noisy, drafty and uncomfortable cockpit of the immortal "Cub."

Manufacturer: Piper Aircraft Corp., Lock Haven, Pa.

Powerplant: One Continental A-65-8 air-cooled engine rated at 65 horsepower.

Dimensions: Wing span, 35 ft. 2.5 in.; overall length, 22 ft. 4.5 in.; wing area, 178.5 square feet.

Normal gross weight: 1,220 pounds.

Payload: Pilot and passenger, tandem seating.

Typical performance: Maximum speed, 100 mph.; cruising speed, 87 mph.; range, about 300 miles.

First flight: 1931 (prototype "Cub"), 1937 (J-3).

Total built: About 24,000 of all models.

PIPER J-3: The best-known lightplane gave wings to thousands.

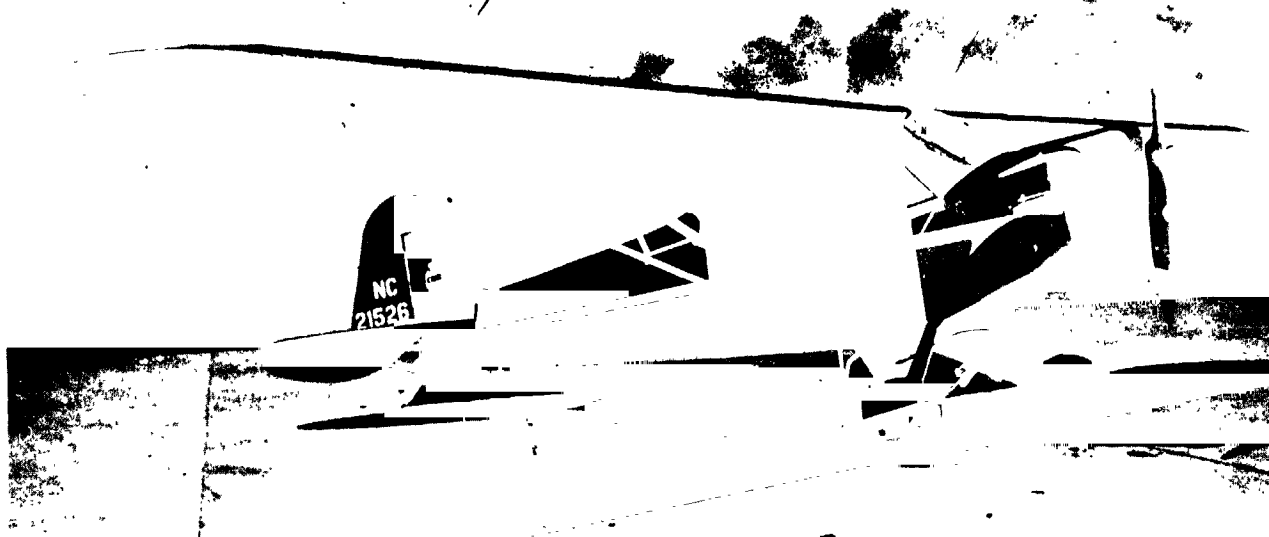

DOUGLAS SBD-5:
The "Dauntless"
and her crews were
tough combat
teams.

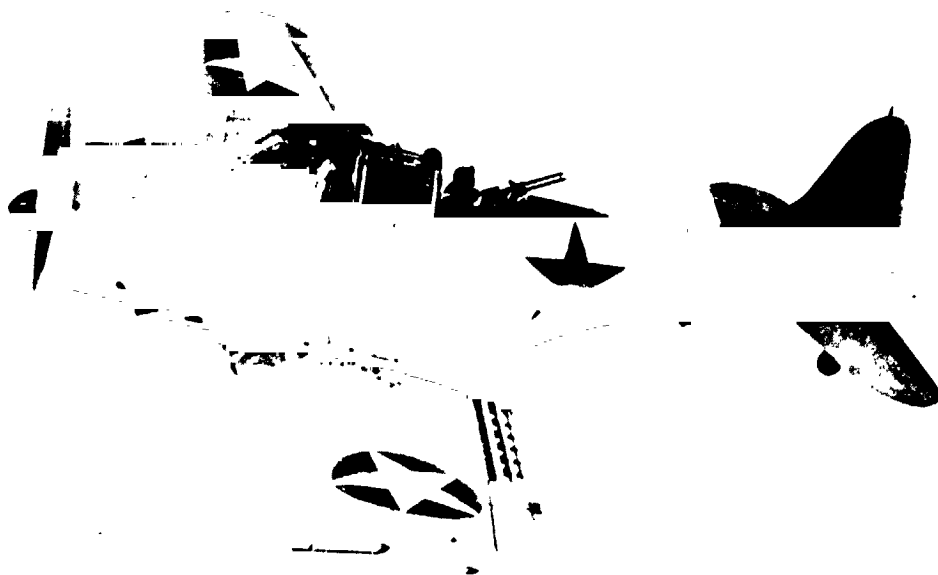

DOUGLAS SBD-5 "DAUNTLESS"

Slow but deadly, they called her, making the appellation fit the initials of her designation. One writer said she was as solid as concrete and as dependable as a tax notice. And from almost the beginning of World War II in the Pacific to its end, she served with Army, Navy and Marine forces, bombing, strafing and fighting from treetop level over the islands to as high as she could climb.

The beginning was in a Northrop design, the XBT-1, which first flew in July 1935. Production BT-1 aircraft followed; they entered the fleet in late 1937, and had been phased out by Pearl Harbor. But the XBT-2, a further development by Douglas who had bought the Northrop El Segundo company and its designs, grew into the SBD-1.

They joined the fleet in 1940, and were on hand when the war began. A replacement aircraft had long since been ordered and was under development, but it did not reach fleet units until near the end of the fighting. Meantime, successive orders for more and more SBDs kept the Douglas production lines full and the service pilots armed.

The SBD series had its deficiencies, viewed in the light of the Navy's requirements at the time. But the aggressiveness of its pilots and gunners, and its ability to turn inside almost any other aircraft once the bombs had been dropped, gave it a fighting edge in air-to-air combat. At the battle

of Midway, two SBDs shot eleven Japanese Zeros out of the sky in aerial combat. It was highly maneuverable, although slow; it was easy to maintain and rugged, so that it could get the crew back home after sustaining battle damage.

The SBD-5 was built in a new Douglas plant at Tulsa, Oklahoma, and was produced in the greatest quantity of any of the series. They began reaching Navy units in late 1943.

Manufacturer: Douglas Aircraft Co., El Segundo, Calif., and Tulsa, Oklahoma.

Powerplant: One Wright R1820-60 air-cooled radial engine rated at 1,200 horsepower.

Dimensions: Wing span, 42 ft. 6.25 in., overall length, 33 ft. 0.13 in.; wing area, 325 square feet.

Normal gross weight: 9,352 pounds; maximum, 10,855 pounds.

Armament: One 1,000-pound bomb; two fixed .50-cal. and two flexible .30-cal. machine guns.

Typical performance: Maximum speed, 252 mph. at 13,800 feet altitude; cruising speed, 139 mph.; range, 1,115 miles with a 1,000-pound bomb.

First flight: August 1938; first production deliveries, May 1940.

Total built: 5,936 of all models, of which 2,964 were SBD-5 models.

CURTISS P-40B

This fighter was inferior to its contemporaries in performance and armament, and it was obsolete from the day it entered service. And yet, in the hands of determined pilots, fighting against odds, the P-40 achieved fame and perhaps immortality.

Before the series terminated, P-40s had seen action in every theater of World War II, and had been flown in combat by the pilots of 28 countries. Thousands were built, making it one of the most-produced military aircraft of the war. And when America entered the war, more P-40s had been built than all other Army fighters together.

It started as the Hawk 75, a low-wing monoplane with a stubby radial engine, developed for the Army Air Corps in November 1934. Winning a competition and a contract, it grew into the P-36A. A new in-line Allison engine offered the promise of better performance in a modified airframe and so, after some detail design work, the XP-40 was born from a P-36 airframe with an Allison engine installation.

The Army ordered the craft into production in a large initial contract. The French ordered 140, but France fell before their delivery and the contract was taken over by the British, then desperate for everything with wings and machine guns. Named "Tomahawk" by the British, the P-40 (or correctly, the H81-A-1 export model) was largely used for training. But later models were better in performance, and their firepower was increased. The first operational "Tomahawks" were those of the Royal Air Force over the North African desert. It was there that the sharkmouth markings originated, later to be adopted by the American Volunteer Group that fought so well in China and Burma with relatively few P-40s.

It was the AVG that developed the battle tactics that made the P-40B and later models tough adversaries. Up against highly professional Japanese pilots, the AVG accounted for nearly 300 victories before it was absorbed into the U.S. Army Air Force.

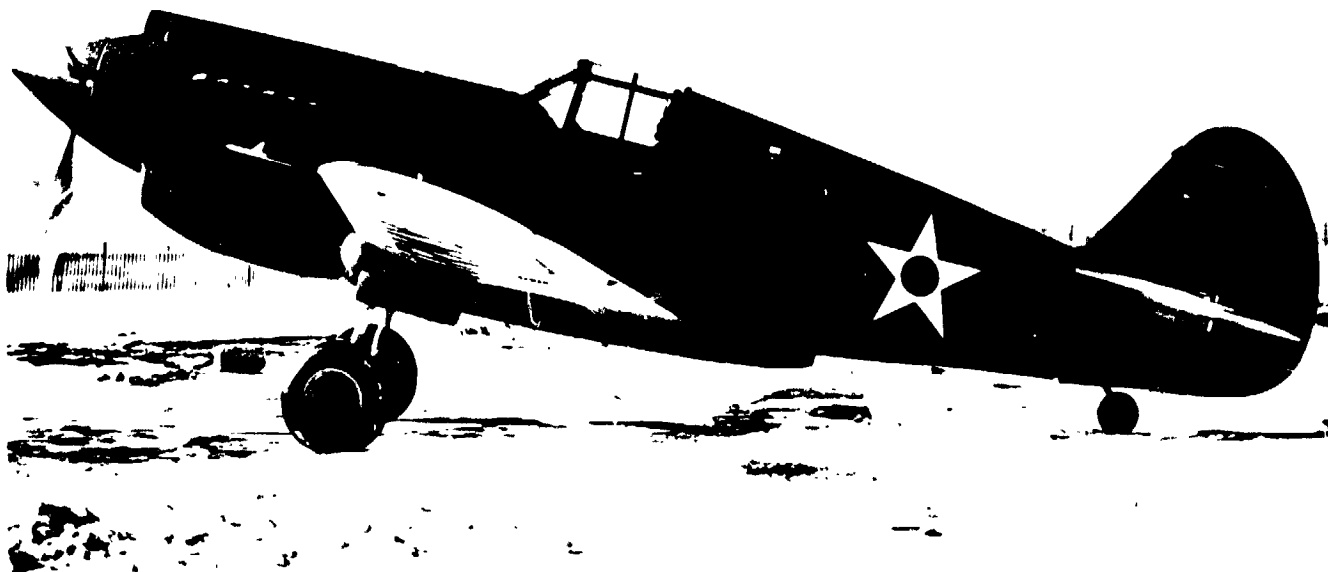

CURTISS P-40B: The "Flying Tigers" developed the tactics that made this fighter famous.

Manufacturer: Curtiss-Wright Corp., Curtiss Airplane Division, Buffalo, New York.

Powerplant: One Allison V1710-33 liquid-cooled engine, rated at 1,040 horsepower.

Dimensions: Wing span, 37 ft. 4 in.; overall length, 31 ft. 8.75 in.; wing area, 236 square feet.

Normal gross weight: 7,326 pounds.

Armament: Four .30-cal. plus two .50-cal. machine guns.

Typical performance: Maximum speed, 352 mph. at 15,000 feet; cruising speed, 273 mph.; range, 730 miles.

First flight: October 1938 (XP-40); first production deliveries, May 1940.

Total built: 13,700 (all models).

LOCKHEED P-38F "LIGHTNING"



LOCKHEED P-38F: This versatile plane ruled the Pacific for the Army.

It was the first turbosupercharged fighter and the first twin-engine single-seater fighter to serve with U. S. squadrons, and its long range and performance at high altitudes made it eventually a very effective weapon in the Pacific theater of war.

But the Lockheed P-38 series was initiated by a 1936 Army requirement for an interceptor and had its share of teething troubles before getting through development and into the hands of service pilots. Almost 300 P-38s were delivered before the Army lifted its prohibition on any combat duties for the type. Consequently, it was not until just before the attack on Pearl Harbor that the first "Lightning" squadrons became operational.

The P-38F was the first model cleared for front-line action; it and its G successor were modified from the original design in detail. The J model was a major change, with relocated cooling systems and increased internal fuel. With the introduction of the J models, the "Lightning" began to come into its own.

It was never popular in the European theater, although it was used as a bomber escort on long-range missions until replaced by the P-47 and P-51 fighters. The Pacific was "Lightning" territory, and it ruled that area for the Army much as the Grumman fighters ruled it for the Navy.

P-38s were converted and adapted to a wide variety of missions during their service careers. They became photo-reconnaissance aircraft, two-seat night fighters, and day bombers in addition to their primary mission. They could carry a bomb load as great as that of a standard B-17, and frequently did, in fighter-bomber missions.

The two top-scoring Army aces of the war, Majors Richard I. Bong and Thomas B. McGuire, achieved their victories while flying the "Lightning."

Manufacturer: Lockheed Aircraft Corp., Burbank, Calif.

Powerplant: Two Allison V1710-111 and -113 turbosupercharged liquid-cooled engines, each rated at 1,425 horsepower for takeoff.

Dimensions: Wing span, 52 ft.; overall length, 37 ft. 10 in.; wing area, 327.5 square feet.

Normal gross weight: 15,341 to 18,000 pounds.

Armament: One 20-mm. cannon plus four .50-cal. machine guns mounted in the fuselage nose; 2,000 pounds of bombs.

Typical performance: Maximum speed, 390 to 400 mph.; range with 2,000 pounds of bombs, 600 to 700 miles; range as escort fighter, 1,500 miles.

First flight: January 27, 1939 (XP-38).

Total built: 9,585 of all models.

MARTIN PBM-3C "MARINER"

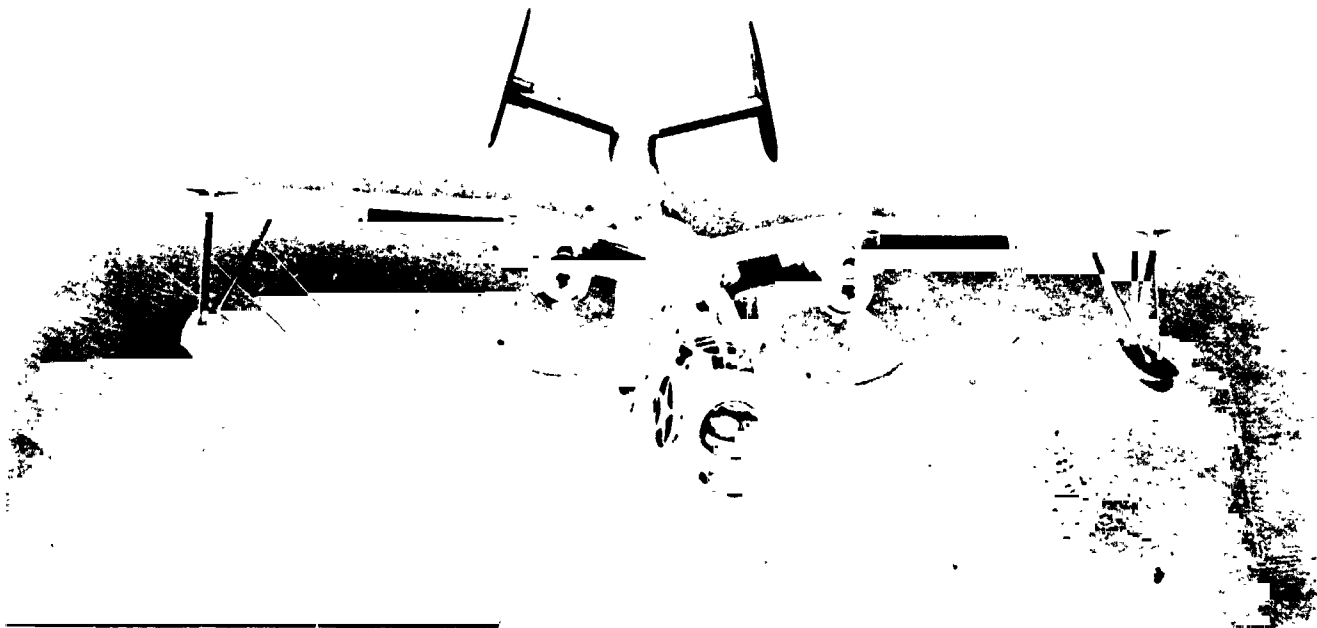

MARTIN PBM-3C: It was versatile, and broadened flying-boat technology.

The PBM series was the first flying boat designed by the Martin Company, although it was to be the fourth they had produced. Their three earlier production boats had been designed either at the Naval Aircraft Factory or at Consolidated Aircraft. But Martin's construction experience paid off in the design of Model 162, a deep-hulled, gull-winged flying boat with a pair of powerful engines.

A later aircraft than the standard Consolidated PBY series, the Martin was more advanced in its aerodynamics and its hydrodynamics. It carried more weapons, both for offense and defense.

After early flight tests of the prototype, the horizontal tail was re-mounted with some dihedral; that canted tail and the gull-wing layout gave the "Mariner" series its unique recognition feature.

In spite of its superior performance, the "Mariner" never was as widely accepted as the PBY, and smaller quantities were ordered. But the "Mariner" lasted through the war and beyond, serving with both the Navy and the Coast Guard in a variety of roles.

As a patrol bomber, it could carry a ton of bombs or depth charges. In later versions, beginning with the PBM-3, the engine nacelles were extended to include the bomb bays for offensive weapons such as bombs. A number of the series was built for transport, and could carry 20 passengers in addition to some cargo.

Search radar was installed above and behind the cockpit, and this system convinced the Navy that the PBM could serve in an anti-submarine role as well.

The last production versions were the PBM-5A model, made amphibious by the addition of retractable landing gear. One aircraft from an earlier batch of PBM-5S anti-submarine aircraft was modified to become the prototype for the later Martin P5M "Marlin" series.

Manufacturer: Glenn L. Martin Co., Baltimore, Maryland.

Powerplant: Two Wright R2600-12 air-cooled radial engines, each rated at 1,700 horsepower (PBM-3C).

Dimensions: Wing span, 118 ft.; overall length, 80 ft.; wing area, 1,408 square feet.

Normal gross weight: 58,000 pounds.

Armament: 2,000 pounds of bombs or depth charges; two .50-cal. machine guns in dorsal and nose turrets, plus one .50-cal. machine gun at each waist and tail position.

Typical performance: Maximum speed, 198 mph. at 13,000 ft.; range, 2,137 miles.

First flight: February 18, 1939.

Total built: 631.

CONSOLIDATED B-24D "LIBERATOR"

This four-engined, long-range bomber was built in greater quantity than any other U. S. military aircraft. It served in all the theaters of World War II, and became the standard bomber in the Pacific because of its range. It fought its way through one of the epic air battles of all time against the heavily defended oil refineries at Ploesti, Rumania. And yet its glory has been eclipsed by the deeds of the Boeing B-17.

Ungainly on the ground, the slab-sided B-24 was more graceful in the air because of its long, tapering wing. It started as a design study of a bomber with performance to be better than that of the B-17. The prototype was built in nine months, and — while it was still in the early stages of flight test — the B-24 was ordered by the Army Air Corps, the French and the British. The first production aircraft went to the British, and were used first as transports across the North Atlantic and later on anti-submarine patrol by RAF Coastal Command.

The B-24D model was the first to enter service with the USAAF, and was the subject of a major production program that involved Consolidated at San Diego and Fort Worth, and Douglas at Tulsa. A major share of the production came from the huge Ford factory at Willow Run, Michigan, where 200 complete B-24Ds were built each month, plus the equivalent of an additional 150 aircraft in major components for assembly elsewhere. North American Aviation at Dallas

also produced B-24s, primarily the later G models. By 1944, unit cost was down to \$215,000.

Versatility described the B-24. Designed as a bomber, it also was used for long-range transport, both photographic and electronic reconnaissance, cargo, anti-submarine duties, and as a tanker. It was operated by the U. S. Army Air Force and Navy, and by the British, in more theaters for longer times than any other bomber, and it was produced in more model versions than any other bomber, Allied or enemy.

Manufacturer: Consolidated Aircraft Corp., San Diego, Calif., and others.

Powerplant: Four Pratt & Whitney R1830-43 and later model air-cooled radial engines, each rated at 1,200 horsepower for takeoff, and each equipped with a General Electric B-22 turbo-supercharger.

Dimensions: Wing span, 110 feet; overall length, 66 ft. 4 in.; wing area, 1,048 square feet.

Normal gross weight: 67,800 pounds, to a maximum of 71,200 pounds at the end of B-24D production.

Armament: 5,000 pounds of bombs (normal), but could carry up to 12,800 pounds; ten .50-cal. machine guns.

Typical performance: Maximum speed, 303 mph. at 25,000 feet altitude; cruising speed, 200 mph.; range, 2,850 miles.

First flight: December 29, 1939 (XB-24).

Total built: 18,188 of all models.

CONSOLIDATED B-24D: Its long range made it dominant in the Pacific.



VOUGHT F4U-1 "CORSAIR"



VOUGHT F4U: The "Corsair" was the war's best carrier-based aircraft.

The "bent-wing bird", last of the American piston-engined fighters in service, had a long and productive life. It started in June 1938, when Vought was awarded a contract for a prototype powered by the huge, new Pratt & Whitney "Double Wasp" engine. The prototype cracked the 400-mph. mark in May 1940, and in June 1941 the company got a production contract.

From then on until December 1952 — eleven years and six months later — the "Corsair" was in continuous production. During those years, it saw service with the U. S. Navy and Marine Corps in World War II, and with the British Royal Naval Air Service and the New Zealand Air Force. It roared off carrier decks and dusty air strips on coral atolls and islands in the Pacific, and tore into Japanese aircraft formations to achieve victory ratios in excess of eleven to one. It was, in sum, the best carrier-based aircraft of that war, and one of the best fighters of the war.

During its life, it was modified to serve as a night fighter, carrying a radome on its right wing. It was armed with cannon instead of machine guns in another model, and carried cameras in a photo-reconnaissance version.

It was built by Brewster and Goodyear as well as by Vought during the war years, and was the basis for a growth version, the F2G-1, developed by Goodyear around the "Wasp Major", a brute of a powerplant with four rows of cylinders.

It was the mount of Navy and Marine aces during the Pacific fighting; Boyington, Foss, Hanson, Walsh, Kepford, Smith and Carl are some of their names.

And then, after the war, it stayed in Naval service and was revitalized for the Korean conflict as the AU-1, fighting there with the Marines in a ground-attack role, developing close-support tactics to a fine point.

The French bought the last production batch, assigned them to their Navy and used them for ground-attack missions in Indo-China and Algeria.

Manufacturer: Vought-Sikorsky Division, United Aircraft Corp., Stratford, Conn.

Powerplant: One Pratt & Whitney R2800-8 "Twin Wasp" air-cooled radial engine rated at 2,000 horsepower for takeoff.

Dimensions: Wing span, 40 ft. 11.7 in.; overall length, 33 ft. 4.6 in.; wing area, 314 square feet.

Normal gross weight: 11,093 pounds (F4U-1); 19,398 pounds (AU-1).

Armament: Six .50-cal. machine guns, later four 20-mm. cannon, plus bomb loads up to 4,000 pounds.

Typical performance: Maximum speed, 417 mph.; cruising speed, 182 mph.; range, about 1,000 miles.

First flight: March 29, 1940 (XF4U-1).

Total built: 12,571.

NORTH AMERICAN B-25H "MITCHELL"

It was the predominant twin-engined bomber in U. S. service during the second World War, and served in every operational theater. Thousands were delivered to the Russians, the British, and other Allied air forces, and more B-25s were built than any other twin-engined U. S. bomber.

It also made a reputation as a gun ship, packing the lethal firepower of eight machine guns in a solid nose and four more in packages on the fuselage sides. One model was converted to carry a 75-mm. cannon for ground strafing, and that installation was later combined in the B-25H with four machine guns in the solid nose and four in packages on the fuselage. Very little could withstand that concentrated blast of metal.

The design dated from 1938; the NA-40 prototype had basically the lines of the later B-25, but without the characteristic bent-wing look caused by the later reduction of outer panel dihedral angle to zero.

B-25s were in service at the time of the Pearl Harbor attack, and immediately went off on anti-submarine patrols over the Pacific. B-25B aircraft were used in the famous strike against Tokyo in April 1942, led by Lt. Col. James H. Doolittle. They took off from the flight deck of the USS Hornet, a Navy aircraft carrier, and — although all of the aircraft and some of the crews were lost — the boost to military and civilian

morale was great at a critical time.

The B-25 was a good-handling aircraft, with consistent, if not outstanding, performance. It could be thrown around in the air much like the more-agile fighters, and had a solid feeling in normal flight regimes.

After the war, they continued to serve with the Air Force and the Navy in a variety of training and support roles. In other countries, they remained as primary bomber aircraft until recent years.

Manufacturer: North American Aviation, Inc., Inglewood, Calif.

Powerplant: Two Wright R2600-13 air-cooled radial engines, each rated at 1,700 horsepower (B-25H).

Dimensions: Wing span, 67 ft. 6.75 in.; overall length, 51 ft. 3.75 in.; wing area, 609.8 square feet.

Normal gross weight: 36,000 pounds.

Armament: One 75-mm. cannon and 14 .50-cal. machine guns (B-25H).

Typical performance: Maximum speed, 293 mph.

First flight: January 1939 (NA-40); August 19, 1940 (B-25).

Total built: 9,815 of all models.

NORTH AMERICAN B-25: Heavily armed, it was the predominant U. S. bomber.

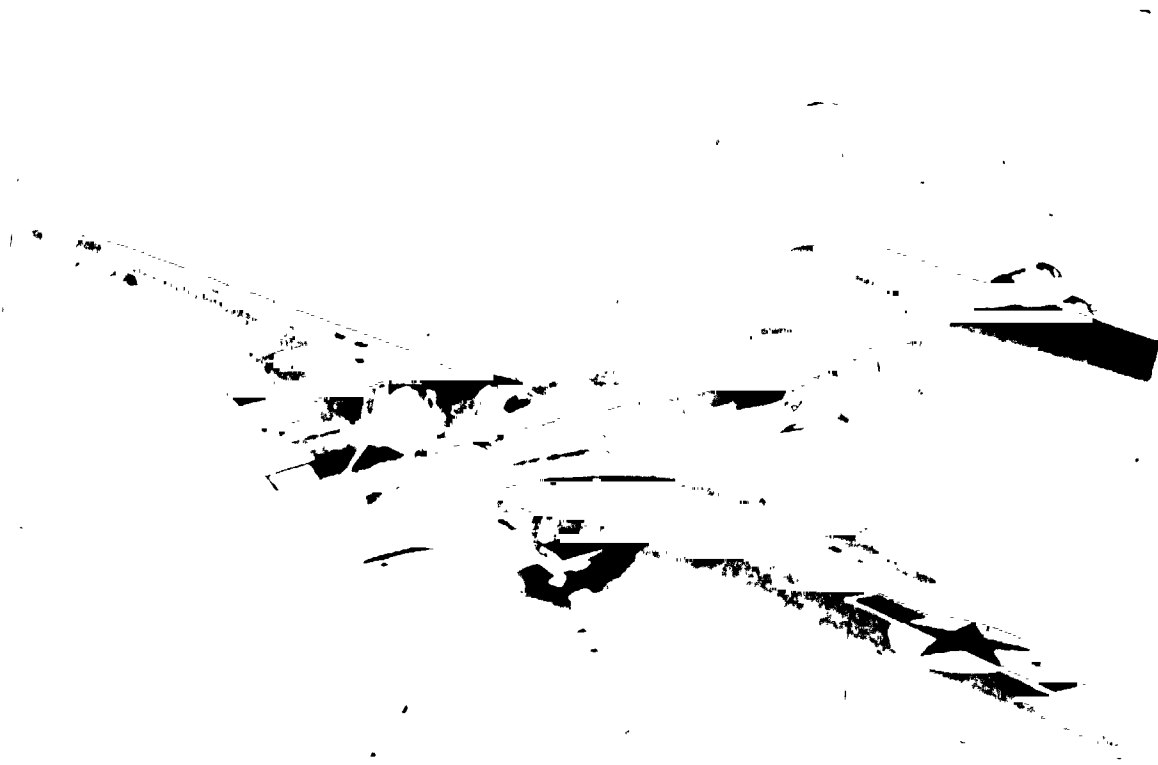

NORTH AMERICAN P-51B "MUSTANG"



NORTH AMERICAN P-51B: The thoroughbred of the skies became a classic in its day.

The "Mustang" was the classic fighter of World War II. Its lines, its performance and its versatility stamped it as a thoroughbred. It has fought in unknown numbers of wars and armed conflicts all over the world. It has carried every available weapon, has flown photo-reconnaissance missions at low and high levels, and has done dive-bombing. After World War II, it was used for racing and even for executive transport. But it almost didn't get off the ground.

The British were responsible for the birth of this remarkable aircraft. In April 1940, they indicated their willingness to buy it off the drawing board if North American would guarantee that the first prototype would fly within 120 days after the signing of the contract. The airplane was ready on time, but the engine wasn't. Nevertheless, the British bought, and the "Mustang I" was off and running.

Four "Mustang Is" were re-engined by the British with the Rolls-Royce "Merlin", and the result was a winner. The P-51B was the first production version of the "Mustang" to use the engine, and it was built under orders placed in 1942 and 1943.

Royal Air Force squadrons first took the plane into combat; the first American missions were flown with P-51Bs December 1, 1943, on a fighter sweep over France. On December 13, P-51Bs and P-38s flew a fighter escort mission for a B-17 bombing raid on Kiel, a round-trip distance of about 1,000 miles. This first escort task for the

"Mustang" emphasized its long range, and — in one way — was the beginning of the end for Germany. From then on, the bomber formations had long-range fighter escorts that could outfight almost anything the Germans ever were to send against them.

The P-51B and its identical twin, the P-51C, served only with Great Britain, the United States, and China, in the European and the China-Burma-India theaters of war. More advanced versions of the "Mustang" were built in much larger quantities and served in the air forces of many countries during and after the war.

Manufacturer: North American Aviation, Inglewood, California.

Powerplant: One Rolls-Royce "Merlin" V1650-3 liquid-cooled engine rated at 1,520 horsepower for takeoff.

Dimensions: Wing span, 37 ft.; overall length, 32 ft. 2.38 in.; wing area, 233 square feet.

Normal gross weight: 9,800 pounds (P-51B).

Armament: Four .50-cal. machine guns and two 500-pound bombs.

Typical performance: Maximum speed, 439 mph.; range, approximately 1,300 miles.

First flight: October 26, 1940 (NA-73 prototype).

Total built: 14,490 of all models were delivered.

REPUBLIC P-47D "THUNDERBOLT"

The beloved, rugged "Jug" was designed as a high-altitude interceptor, and its barrel-shaped fuselage was the result of a turbo-supercharger installation aft of the cockpit. The ducting necessary to carry the engine exhaust and air to that supercharger and back made up a large portion of the interior of the fuselage.

The P-47 originated in pre-war requirements for new fighters for the Army Air Force. The powerplant around which the P-47 was planned required a four-bladed propeller of large dimensions. Eight .50-caliber machine guns, the heaviest armament yet adopted in any fighter design, were installed in the wings. The result was a prototype that outweighed, but also outperformed, anything in its class.

There were problems, common to many high-speed aircraft, in getting the "Thunderbolt" to behave, and there were delays in getting it operational. Early P-47Bs, first blooded in combat in 1943, were outmaneuvered and outclimbed at moderate to low altitudes by enemy fighters. They also lacked range, and belly tanks were soon fitted to compensate for that deficiency.

It was the D model, with water injection for increased horsepower, and improved armor, that finally made the P-47 into the long-range escort fighter that the bomber forces so desperately needed. In total, more than 80 percent of all "Thunderbolts" were the D model, with the

performance that enabled them to stay with bomber formations as top cover, to fight off enemy attacks, and to take on ground targets on the way home. It was this latter tactic that led to their later and most successful use as fighter-bombers.

In that interdiction role, "Thunderbolts" destroyed thousands of locomotives, railway rolling stock, tanks and trucks. Their combat record was impressive; pilots claimed 3,752 enemy aircraft destroyed for losses of 824 P-47s. The actual loss rate in combat was less than one percent.

Manufacturer: Republic Aviation Corp., Farmingdale, N. Y.

Powerplant: One Pratt & Whitney R2800-21 air-cooled radial engine rated at 2,300 horsepower

Dimensions: Wing span, 40 ft. 9.31 in.; overall length, 36 ft. 1.75 in.; wing area, 300 square feet.

Normal gross weight: 13,500 pounds.

Armament: Eight .50-cal. machine guns plus one 500-pound bomb.

Typical performance: Maximum speed, 433 mph. at 30,000 feet.

First flight: May 6, 1941 (XP-47).

Total built: 15,683, all models, of which 12,602 were Ds.

REPUBLIC P-47D: It met a desperate need for a long-range fighter.

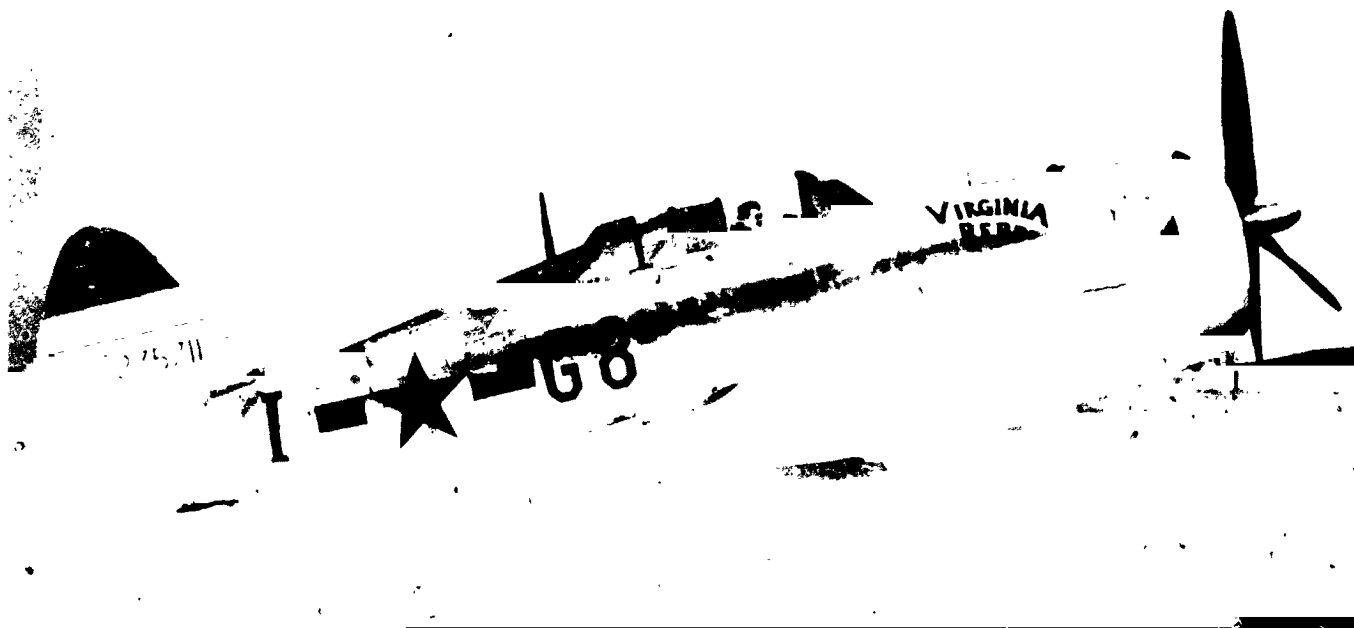

SIKORSKY R-4B

It was the world's first production helicopter, ordered in 1940 on the strength of observations and a film of Igor Sikorsky's perambulations in the VS-300, his experimental helicopter. The Army had earlier committed most of its funds for such projects to the development of the Platt-LePage XR-1, a helicopter design that was running into trouble. But some additional funds were found and the XR-4 was approved for construction and testing.

While being built, the XR-4 design was constantly checked and improved by results from the VS-300 flights. In its final form, that test helicopter resembled the layout of the refined XR-4; they shared the common layout of three-bladed main and tail rotors.

When the XR-4 was rolled out in December 1941, it looked incomplete. Its fuselage was only

partially enclosed, and the trusswork structure of the rear portion was open to the air.

After some flight tests, it was decided to ferry the XR-4 cross-country to the Army's Wright Field, near Dayton, Ohio, for additional acceptance and service testing. It took five days to make the 761-mile journey; the XR-4 was eased across country gently, because it was the only one of its kind.

The XR-4 grew a bit into the YR-4, with larger main rotor, increased horsepower, more fuel and a radio for communications. In turn, that model gave way to the YR-4B, of still greater horsepower, and the production R-4B, which became the first true production helicopter in the world.

From this strange-looking, little helicopter came the long lines of single-rotor craft which are so familiar today all over the world.



SIKORSKY R-4B:

An experiment grew to the first production helicopter.

Manufacturer: Sikorsky Aircraft Division of United Aircraft Corp., Bridgeport, Conn.

Powerplant: One Warner R500-1 "Super Scarab" air-cooled radial engine rated at 185 horsepower.

Dimensions: Rotor diameter, 36 ft.; overall length, 32 ft. 3 in.

Normal gross weight: 2,449 pounds (XR-4).

Payload: Two-man crew.

Typical performance: Maximum speed, 82 mph. at sea level; cruising speed, 65 mph.; range, about 200 miles.

First flight: January 14, 1942 (XR-4).

Total built: One XR-4; three YR-4A; 27 YR-4B; and 100 R-4B, for a total of 131.

DOUGLAS A-26 "INVADER"



DOUGLAS A-26: The "Invader" was fast, versatile, and the end of a line.

Aerodynamically, it was a beauty, with clean lines and powerful engines, and it was the end of the line for piston-engined attack aircraft. Double-slotted flaps slowed its performance for easier landings; but cleaned up, the A-26 was a fast and versatile attacker.

Engineering began on the "Invader" in January 1941. Three experimental units were ordered in May, and by October, progress with the design and the obvious pressures of a possible war prompted the Army to order 500 production models. The first experimental XA-26 had yet to fly.

When it did, the Army knew it had a winner. It had been designed as an all-purpose attacker, with three different nose configurations: One, all plexiglas, for operations as a light bomber; the second, with a longer radome-tipped nose and a quartette of cannon slung below for night-fighting; the third, a short nose housing a 75-mm. cannon for strafing ground targets.

The thorough test program — for this was to be the last attack aircraft designed and built for the U. S. military — proved the performance and the ruggedness of the A-26, but it also delayed introduction into service. By late 1944 the first USAAF units were in action with the A-26 in Europe and, a few months later, in the Pacific. The war ended; the A-26s were put into storage. And then the Korean conflict erupted. Out of storage came A-26s. Re-designated as B-26s,

they flew into combat in night attacks on supply lines. Later, the French used B-26s in Algeria and Indo-China. Still later, some came out of storage again and were modified in 1964 to a B-26K model, sent to Southeast Asia, and used for night interdiction in combat over the Ho Chi Minh trail.

They also served with the Brazilian, Peruvian, Saudi Arabian, South Vietnamese and Turkish air forces. Some were made into high-speed executive aircraft; others were bought surplus and — by devious routes — turned up in odd corners of the world, unmarked, but armed, fighting in the hands of mercenary pilots. Four or five are used currently in forest firefighting in Canada.

Manufacturer: Douglas Aircraft Company, Long Beach, Calif., and Tulsa, Oklahoma.

Powerplant: Two Pratt & Whitney R2800-79 air-cooled radial engines rated at 2,000 horsepower each.

Dimensions: Wing span, 70 ft.; overall length, 50 ft. 9 in.; wing area, 540 square feet.

Normal gross weight: 35,000 pounds.

Armament: 4,000 pounds of bombs internally plus 2,000 pounds externally; wide variety of gun noses.

Typical performance: Maximum speed, 360 mph.; combat range, about 1,000 miles.

First flight: July 10, 1942.

Total built: 2,446, all models.

BOEING B-29 "SUPERFORTRESS"

Designed specifically to bomb the Japanese empire, the Boeing B-29 was a decisive factor in forcing the final surrender of Japan.

It was a mammoth for the time, with the four most-powerful engines available. Its graceful wings supported a long, cylindrical fuselage that carried a maximum bomb load of eight tons. Portions of that fuselage were pressurized; the pilots forward, and the gunners amidships, worked in relative comfort, their duty stations connected by a long tunnel.

Remote gun turrets provided the defensive weapons, aimed and fired by gunners using electro-optical sights in blisters amidships. Both the remote power-operated turrets and the pressurization were "firsts" in bomber design.

The B-29 was ordered "off the drawing board" in May 1941, and more than 1,600 had been ordered before the prototype XB-29 ever flew. They were built by Bell Aircraft Corporation and the Glenn L. Martin Company, as well as by Boeing, in a massive production program that involved thousands of sub-contractors.

Their military life during World War II was a little over one year; they entered combat in June, 1944, bombing targets in Thailand. They dropped the two atomic bombs, one at Hiroshima and the other at Nagasaki.

At the time of the Korean conflict, the then-aging "Superfortresses" went into action almost at the start, and flew right through to the end of that war.

During their service, the B-29s racked up records for speed, distance, and the first non-stop round-the-world flight. Modified, they served as mother ships to research aircraft like the Bell XS-1. They were copied and produced in Russia as the Tu-70 bombers. They lasted in the U.S. Air Force inventory until June 1960.

Manufacturer: Boeing Aircraft Company, Seattle, Wash.

Powerplant: Four Wright R3350-23 and later models, air-cooled radial engines rated at 2,200 horsepower each.

Dimensions: Wing span, 141 ft. 2.75 in.; overall length, 99 ft.; wing area, 1,739 square feet.

Normal gross weight: 105,000 pounds.

Armament: 16,000 pounds of bombs; five remote turrets.

Typical performance: Maximum speed, 365 mph. at 25,000 ft.; cruising speed, 220 mph.; range 5,830 miles.

First flight: September 21, 1942 (XB-29); first production deliveries began in August 1943.

Total built: 3,974.

BOEING B-29: Airpower personified, it was decisive in Japan's surrender.



BELL P-59A "AIRACOMET"



BELL P-59A: America's first jet, it was designed for combat it never saw.

It was the first jet aircraft developed in America, and was designed for a combat role. It confirmed the basic concept of jet propulsion for military aircraft, blazed the way for the thousands of military and commercial U.S. jet aircraft to follow, and trained the first USAAF cadre of jet pilots to bridge the gap between piston-engined and turbojet-powered fighters.

Initiated by Maj. Gen. H. H. Arnold, Chief of the USAAF, following a visit to England and inspection of their turbojet development, the Bell XP-59A was built around two General Electric I-A turbojets, derived from the British Whittle W2B engine.

The flight test site was selected in the California desert, on a section of the Army Air Force Muroc Bombing and Gunnery Range, now Edwards Air Force Base, home of USAF experimental flight research.

Three experimental aircraft began the test program, followed by 13 development YP-59A models. Three of these, with GE I-16 engines, were flown against the Lockheed P-38J and the Republic P-47D in mock combat trials.

The primitive state of jet propulsion art doomed the "Airacomet" to be a trainer; it was outclassed by the best of the piston-engined fighters and it was not a good gunnery platform.

There were problems with the engines, which ran unevenly. The performance was less than

expected, because the engine data from British sources proved to be optimistic. The predicted thrusts were not achieved either in the original or the later production engines.

The first operational unit to be equipped with the "Airacomet" was the 412th Fighter Group, a training organization for pilots and mechanics. They were assigned 19 of the new aircraft, and were the only service unit so equipped. Other P-59 aircraft were assigned to the Navy and to the NACA for test work.

Manufacturer: Bell Aircraft Corporation, Buffalo, N. Y.

Powerplant: Two General Electric Co. I-16 turbojets, rated at 1,650 pounds of static thrust each (P-59A).

Dimensions: Wing span, 45 ft. 6 in.; overall length, 38 ft. 10 in.; wing area, 385.8 square feet.

Normal gross weight: 10,822 pounds.

Armament: One 37-mm. cannon and three .50-cal. machine guns.

Typical performance: Maximum speed, 409 mph. at 35,000 feet altitude.

First flight: October 1, 1942 (XP-59A). First production deliveries were made in December 1944.

Total built: 66, including three XP-59A, 13 YP-59A, 20 P-59A-1, and 30 P-59B.

KELLETT YO-60



KELLETT YO-60: A vanished dream, the autogiro promised much but delivered little.

By the mid-Thirties, aviation had discovered the autogiro and so had the public. There were predictions that everyman's aircraft finally had arrived, and that sport fliers would be landing at their doorsteps and taking off from their backyards in these marvelous new craft. The military got into the act by ordering a few small batches of autogiros for test and evaluation.

One of these was the Kellett YO-60, ordered as an observation aircraft for the Army. It was a development of the Kellett YG-1B, which was an earlier Army test vehicle. And that in turn was the development of a still earlier Kellett design.

They all had the autogiro principle in common: The rotor, set atop the fuselage on a pylon, was driven only by the air loads on the blades. There was no engine to drive the rotor shaft, as was the case with the later helicopters. The autogiro did have an engine, but in these early models, it was used solely for forward propulsion. Only in advanced autogiros developed some years later was there an auxiliary drive with a clutch to start the rotor spinning for a "jump" takeoff.

The YO-60 differed from the YG-1B in its enclosed cockpit and increased power. Otherwise, it was essentially identical to the earlier Kellett design, with its three-bladed rotor and characteristic lines.

Manufacturer: Kellett Autogiro Corp., Philadelphia, Penn.

Powerplant: One Jacobs R915-3 air-cooled radial engine rated at 300 horsepower.

Dimensions: Rotor diameter, 43 ft. 2 in.; overall length, blades folded, 25 ft. 11 in.

Normal gross weight: 2,640 pounds.

Typical performance: Maximum speed, 127 mph.

First flight: 1942 (YO-60).

Total built: Seven.

LOCKHEED P-80A "SHOOTING STAR"

It was too late for its intended war and was obsolescent when it went into combat just a few years later. But the "Shooting Star", the Army's first operational jet fighter, proved to be combat worthy. It also fathered a long line of training aircraft used by 19 different air arms.

On June 17, 1943, Lockheed was asked informally to design a jet aircraft that could do the job that the Bell P-59, first U. S. military jet aircraft, was not going to be able to do. The Army approved Lockheed's design six days later, and added that the first airplane had to be flying within 180 days. This was the origin of Lockheed's famous "Skonk Works" concept, which isolated a project team with a single goal. There were 23 engineers and 105 technicians in that first effort, and on the 143rd day, the XP-80 was rolled out, ready for flight.

The original engine was a British development, the Halford H.1, built by the de Havilland engine works. But its production lagged, and the XP-80 was re-engined for production.

As the XP-80A, the new design took 138 days to get ready for flight. Production followed, and by the end of the war, Lockheed had delivered more than 100. A handful were operational with Air Force squadrons in England and Italy for

familiarization flights.

Five years passed, and the Korean conflict erupted. The only operational combat-ready jet fighters were F-80C aircraft, and they joined action over Korea, winners in the first jet dogfight November 8, 1950.

The P-80 (or F-80 as it was later designated) was the basis for development of the F-94 night-fighter series, and the T-33, standard USAF trainer.

Manufacturer: Lockheed Aircraft Corp., Burbank, Calif.

Powerplant: One General Electric I-40 (J53) turbojet (XP-80A); one Allison J33-A 23 turbojet, rated at 4,600 pounds of thrust (P-80C).

Dimensions: Wing span, 38 ft. 10.5 in.; overall length, 34 ft. 6 in.; wing area, 237.6 square feet.

Normal gross weight: 15,350 pounds.

Armament: Six .50-cal. machine guns; 16 underwing rockets.

Typical performance: Maximum speed, 580 mph.; maximum radius of action, 350 miles.

First flight: January 9, 1944 (XP-80).

Total built: 1,731, including one XP-80, two XP-80A, 13 YP-80A, 917 P-80A and 798 P-80C.

LOCKHEED P-80A: Proven in combat, it fathered a long line of trainers.



GRUMMAN F8F-1 "BEARCAT"



GRUMMAN F8F-1: Its speed won the "Bearcat" a niche in aviation history.

This last piston-engined fighter ordered by the U.S. Navy never saw combat during World War II. But its place in aviation history is secure because of one facet of its outstanding performance: Years later, it regained the world's absolute speed record for piston-engined airplanes for the United States.

In the early days of World War II, there was an obvious need for a high-performance interceptor to defend Naval carriers from attack; the need became more pressing as the desperate Japanese adopted suicide tactics later in the war.

The F8F series was designed to be that interceptor, and two prototypes were ordered in November 1943. Production orders were placed little more than a year later, and deliveries began in February 1945. The war ended before any "Bearcats" saw combat, although the first squadrons had been carrier-qualified and were ready to move out into the Pacific.

It was built also as a night-fighter and as a photographic airplane. Production ended in 1949, cut back considerably from the original wartime orders which totaled, on paper, almost 4,000 planes, to have been built both by Grumman and the Eastern Aircraft Division of General Motors.

They had a relatively short life in the fleet, being phased out beginning in 1949. The photographic versions were last to go in 1952. Some

were converted into target drones, and others went to the French and the Royal Thai air forces, for combat over Indo-China.

A number of them have been modified and developed by private owners into unlimited class racing aircraft, and have established some spectacular performance marks. But none was quite as satisfying as the 482.642 mph. world record set by pilot Darryl Greenamyer on August 16, 1969, in a reworked F8F-2.

Manufacturer: Grumman Aircraft Engineering Corp., Bethpage, New York.

Powerplant: One Pratt & Whitney R2800-34W air-cooled piston engine rated at 2,100 horsepower for takeoff.

Dimensions: Wing span, 35 ft. 10 in.; overall length, 28 ft. 3 in.; wing area, 244 square feet.

Normal gross weight: 12,947 pounds.

Armament: Four .50-cal. wing-mounted machine guns; F8F-1B carried four wing-mounted 20-mm cannon.

Typical performance: Maximum speed, 421 mph. at 19,700 feet altitude (military versions); cruising speed, 163 mph. for long range; range, 1,105 miles.

First flight: August 21, 1944 (XF8F-1).

Total built: 1,260 of all models.

DOUGLAS AD-1 "SKYRAIDER"

Born in 1944 to requirements determined by the war in the Pacific, the Douglas "Skyraider" matured to fight in the Korean conflict and the war in Southeast Asia. Along the way, it changed from its original concept of a bomber and torpedo-dropper to an attack aircraft that could carry 8,000 pounds of weapons under its wings and fuselage, and snoot its way in and out with 20-mm. cannon.

The versatile "Skyraider" was born of an effort to keep Douglas in the Naval attack aircraft business. The company's SBD replacement, the BTD project, had been cancelled, and two other companies already were competing for the next Navy attack craft. Douglas designers worked rapidly to produce a proposal; the Navy reviewed it, allowed Douglas to join the competition, and Douglas won with its XBT2D-1 design.

High lift and low weight were major design criteria, and when the XBT2D-1 flew early in 1945 it lifted off at a weight about 1,000 pounds under the guarantee. Less than two months later, the Navy ordered an initial quantity of 548, and the program was on a firm foundation.

Later cutbacks reduced that number; the designation and the name were changed to AD-1 "Skyraider." Early developmental tests with prototype aircraft showed the versatility of the basic concept, and from then on, orders progressed in a steady stream.

The Korean conflict was its first combat deployment, and it served as ". . . the most

successful airplane of the 37-month war", according to an official Navy history. In 1961 the "Skyraider" again went into combat, flown by South Vietnamese pilots and American instructors. Both the U. S. Navy and Air Force used the aircraft, and a number also were operated by the South Vietnamese.

The last AD was retired from the Navy in 1968, ending 23 years of service with the fleet. Few aircraft can boast of a longer career, and none of a more-versatile one.

Manufacturer: Douglas Aircraft Co., El Segundo, Calif.

Powerplant: One Wright R3350-24W or later air-cooled radial engine, rated at 2,500 to 2,700 horsepower for takeoff.

Dimensions: Wing span, 50 ft.; overall length, 38 ft. 6 in. (AD-1); wing area, 400 square feet.

Normal gross weight: 16,000 pounds (AD-1 to AD-3); 17,000 pounds (later versions); maximum overload weight, 25,000 pounds.

Armament: Two 20-mm. forward-firing cannon (AD-1); up to 8,000 pounds of weapons under wings and fuselage.

Typical performance: Maximum speed, 320 mph. at 18,500 ft. altitude; cruise speed, 190 mph.; range, 900 miles.

First flight: March 18, 1945.

Total built: 3,180 of all models.

DOUGLAS AD-1: Veteran of two wars, it served the Navy for 23 years.

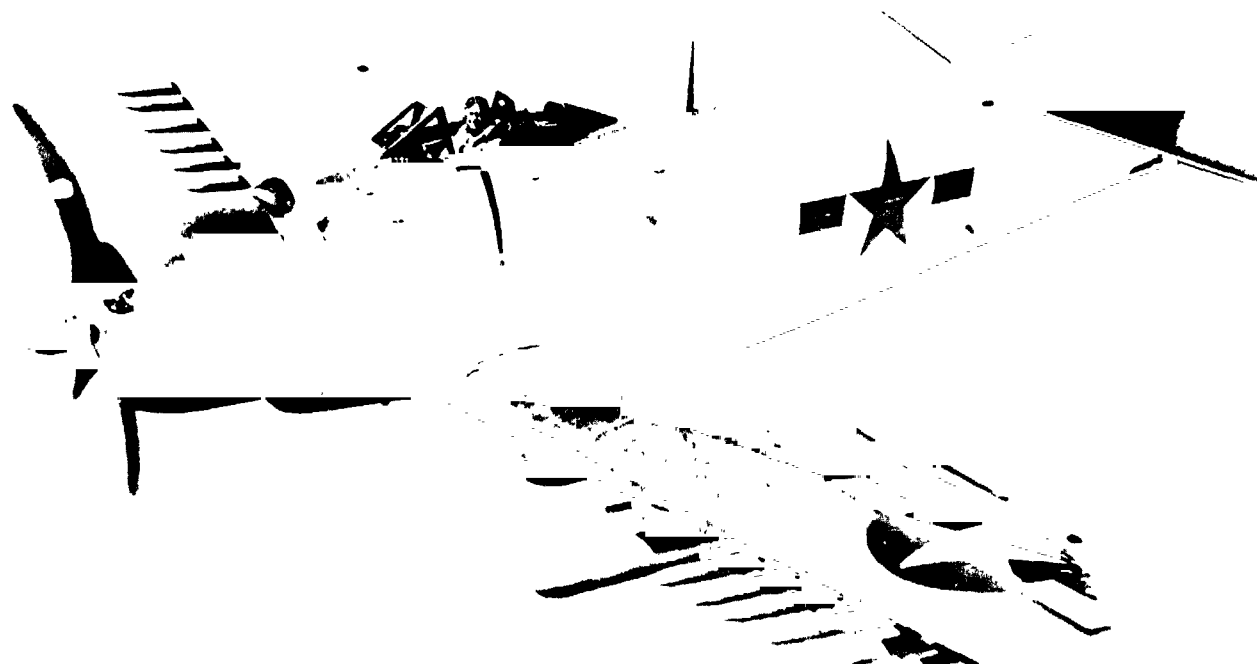

CONVAIR B-36D

This first intercontinental bomber with really long range was designed to requirements developed in April 1941, eight months before this country was plunged into World War II.

The design was submitted in August 1941, outlining a bomber that would carry 10,000 pounds of bombs over a distance of 10,000 miles. It would rely on its speed and maneuverability at high altitude for defense, but it would also be heavily armed with remotely fired turrets.

Fully pressurized, the cylindrical fuselage housed the 21-man (16 plus five relief) crew in two compartments connected by a tunnel.

Its gestation was long, because of the immediate commitments to development and production of a fighting force for the war at hand. But it became the backbone of this country's deterrent in the postwar years with the Strategic Air Command.

During most of its operational life, the B-36 was embroiled in controversy. It was criticized as lacking in performance at the very time that it was demonstrating its performance in excess of the requirements. And the question of its vulnerability, raised by ardent proponents of the then-new jet fighter, was never settled publicly. But privately, there was more than one occasion when friendly fighters, trying to attack what seemed like a lumbering target, were left floundering at high-altitude out of control after trying to turn in on a pursuit curve.

Later models of the B-36 were equipped with four jet engines for extra speed performance over the target. Other models were adapted for tests of fighters modified to be carried in the B-36 bomb bay or underneath its fuselage, for protection and for reconnaissance. B-36s were operational with SAC from June 1948 to May 1958.



CONVAIR B-36D: America's postwar deterrent strength rode its wings.

Manufacturer: Consolidated-Vultee Aircraft Corp., Fort Worth, Texas.

Powerplant: Six Pratt & Whitney R4360-41 air-cooled turbosupercharged radial engines, each rated at 3,500 horsepower, plus four General Electric J47-GE-19 turbojets, each rated at 5,200 pounds of thrust (B-36D).

Dimensions: Wing span, 230 feet; overall length, 163 feet; wing area, 4,772 square feet.

Normal gross weight: 357,500 pounds (B-36D).

Armament: Normal bomb load, 10,000 pounds; maximum bomb load, 72,000 pounds; sixteen 20-mm. cannon in eight turrets.

Typical performance: Maximum speed, 435 mph.; cruising speed, 225 mph.; range, 12,000 miles with 10,000 pounds of bombs.

First flight: August 8, 1946 (XB-36).

Total built: 385

BELL XS-1



BELL XS-1: It was the first to fly faster than the speed of sound.

The world's first supersonic aircraft, the tiny Bell XS-1 was originally designed as a research aircraft to explore the region around the speed of sound. The ideas that led to its development originated about 1943; they took form in the first of a long series of research aircraft that advanced the technology of aviation almost beyond measure.

With so little then known about high-speed flight, the XS-1 design was conservative. The fuselage was shaped like a .50-cal. bullet, on which some test data were available. The wings were stressed for 18 times the normal weight of the airplane, to allow for the anticipated high loads in flight.

The fundamental choice of rocket power was one major design criterion; so was the decision to air-launch the XS-1 from a mother ship rather than require it to have the ability to take off from the surface.

Bell got a letter contract on March 12, 1945 and built three of the research craft, originally under the designation of MX-524, then MX-653, then XS-1, and eventually (1948) as the X-1.

First flights were the responsibility of the contractor; Bell pilots made the first unpowered glides to check the systems of release from the

B-29 mother ship and to perfect the landing technique. They also made the first powered flights, up to the edge of the transonic region.

Then the Army Air Force took over its share of the program and began the build-up to the maximum speed and altitude capabilities. On the ninth Air Force flight, October 14, 1947, Air Force Capt. Charles E. Yeager became the first pilot to travel faster than the speed of sound. The Bell XS-1 had reached Mach 1.06, and had secured its niche in history.

Manufacturer: Bell Aircraft Corporation, Buffalo, N. Y.

Powerplant: One Reaction Motors, Inc., 6000-C4 liquid rocket engine, delivering 6,000 pounds of thrust.

Dimensions: Wing span, 28 ft.; overall length, 31 ft.; wing area, 130 square feet.

Normal gross weight: 13,390 pounds; landing weight, 5,200 pounds; useful load, about 500 pounds of scientific instrumentation.

First flight: January 19, 1946 (unpowered glide); first powered flight, December 9, 1946.

Total built: Three.

BOEING MODEL 377 "STRATOCRUISER"

It will be remembered forever as the airplane with the bar downstairs. Others will recall it as the best three-engined trans-Atlantic transport. The Boeing 377 "Stratocruiser" which actually had four engines, was both of these, and more.

Developed as a commercial version of the Air Force C-97 cargo transport, the Model 377 was a large, roomy and comfortable transport that carried passengers in space that hasn't since been duplicated. Its wide seats, legroom, headroom, and that downstairs bar made it a favorite, even though an engine occasionally failed in flight.

The "Stratocruiser" was developed as a mix of three earlier Boeing aircraft. From the B-29 came the wing, tail and landing gear, which were also used on the C-97. From the C-97 came the fuselage. And from the B-50 came the powerplants.

Six different airlines bought the original production aircraft at about \$1.5 million each, and equipped the "Stratocruisers" for de-luxe service, usually across the oceans. The interior layout could have handled as many as 114 passengers, but in practice the maximum seating capacity used by an initial customer was 61. Some were fitted as sleepers, with 28 upper and lower berths, and they are fondly remembered by

veteran travelers as the finest way to cross the Atlantic ever devised by man.

Dressing rooms were provided, in addition to the usual toilet accommodations. The galley installed at the rear of the aircraft was the most complete of any used up to that time, and could handle two complete meal and liquor services for the full complement of passengers.

They lasted too briefly on the oceanic services. They were replaced by less roomy, but far more economical, aircraft that set the patterns for today's distant travel.

Manufacturer: Boeing Airplane Company, Seattle, Wash.

Powerplant: Four Pratt & Whitney R4360 TSB3-G "Double Wasp", 28-cylinder air-cooled radial engines, rated at 3,500 horsepower each for takeoff.

Dimensions: Wing span, 141 ft. 3 in., overall length, 110 ft 4 in.; wing area, 1,720 square feet.

Normal gross weight: 135,000 to 148,000 pounds.

Payload: From 55 to 114 passengers.

Typical performance: Maximum speed, 375 mph.; cruising speed, 340 mph.; range, 4,200 miles.

First flight: July 8, 1947 (prototype); first production delivery was made in February 1949.

Total built: 55.

BOEING 377: The "Stratocruiser" is remembered for its space and comfort.

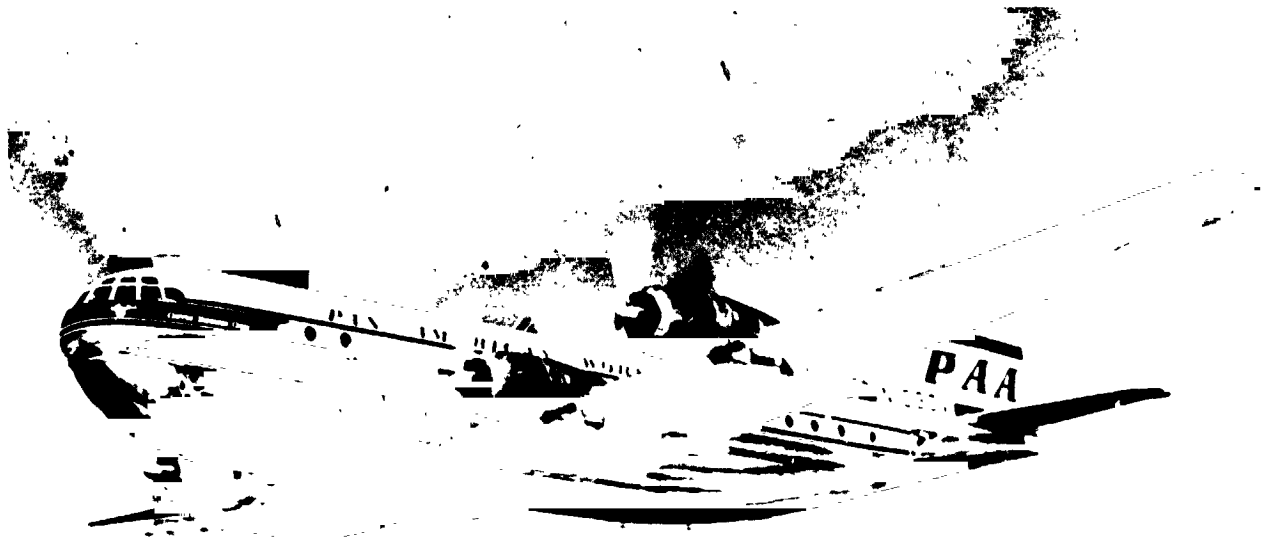

NORTH AMERICAN F-86F "SABRE"



NORTH AMERICAN F-86F: The "Sabre" was blooded in combat over Korea.

This country's first swept-wing jet fighter will be remembered as a veteran of combat high above Korea and as a defender of the free world in the air forces of many Asian, European and Latin American countries.

It originated as a straight-winged Navy fighter, and was adapted to an Army Air Force requirement for a day fighter, an escort fighter, and a dive bomber in late 1944. By mid-1945, German wind-tunnel data on wing sweepback had been seized, studied and used to convert the straight-winged design to the swept-wing geometry that characterized the entire line of "Sabres."

It was the F-86A version that was rushed into combat in the Korean conflict, where it accounted for many times its own losses in enemy aircraft destroyed. That tough proving-ground for the design resulted in a number of changes which were to become standard in later models. One of these was the all-flying tail, for better control and maneuverability at high speeds. It was a feature of the F-86E, and was kept in the line from that model on.

The F-86F featured more thrust and therefore better performance. It retained the all-flying tail, added a new wing leading edge which improved the high-speed performance, and carried a wider variety of more external weapons and fuel tanks. Surplus F models were exported to a dozen countries.

Late model F-86F aircraft were fitted with the automatic leading-edge slat which had been

deleted earlier when the high-speed leading edge was introduced. Further modifications led to the F-86H, with a larger engine and deeper fuselage.

The F-86D, although related by wing design, was basically a different aircraft. It was developed as an all-weather interceptor with a nose radome and all-rocket armament, and further developed into the cannon-armed F-86K for NATO countries, and the F-86L, which was a modernized D model.

The F-86F was produced in greater numbers than any of the other "Sabre" models, and is representative of the whole line.

Manufacturer: North American Aviation, Inc.,
Inglewood, Calif.

Powerplant: One General Electric J47-GE-27 turbojet
rated at 5,910 pounds of thrust.

Dimensions: Wing span, 39 ft. 1 in.; overall length,
37 ft. 6.5 in.; wing area, 313 square feet.

Normal gross weight: 15,198 pounds.

Armament: Six .50-cal. machine guns plus two AIM-98
"Sidewinder" air-to-air missiles; bombs and rockets.

Typical performance: Maximum speed, 604 mph. at
35,000 feet; combat radius, 463 miles with drop
tanks.

First flight: October 1, 1947 (XP-86).

Total built: 8,433 of all types, of which 1,539 were
F models.

BOEING B-47E



BOEING B-47E: Its thin, swept-wing layout influenced later designs.

For fifteen years, Boeing B-47s were in service with the deterrent force of the Strategic Air Command, USAF. This first swept-wing bomber was a revolutionary aircraft when it first appeared in 1947; it influenced later aircraft designs, including the long line of Boeing commercial jet transports.

It was originally designed with straight wings, but early access to German wartime wind-tunnel data convinced Boeing to use sweepback for high-speed performance.

As a major foundation stone of U. S. postwar airpower, the B-47 became a production program involving three companies: Boeing at Wichita, Kansas; Lockheed at Marietta, Georgia; and Douglas at Tulsa, Oklahoma.

The concept was a simple one: The B-47 was designed to carry the atomic bomb and to rely on speed and maneuverability at high altitudes for defense.

Its innovations were many. The swept wing was thin and flexible; it deflected frighteningly but safely under loads. The landing gear was a bicycle type, and wing outriggers were used for added ground stability. The six podded engines had to be precisely located to help dampen, instead of augment, the wing deflections in flight. Spoilers were used in addition to the ailerons to help the maneuverability.

Solid-rocket JATO (Jet-Assisted Take-Off) motors, attached to the fuselage sides, were used

to improve takeoff performance on hot days or at altitude. Drogue parachutes were pioneered as an aid to landing at high power settings, a safety measure in the event of the need to go around again.

The B-47B was the first real production model, and the first to enter service with the Strategic Air Command. The B-47E was a major improvement in the series, featuring more powerful engines, increased weight, ejection seats for the crew, and in-flight refueling.

The aircraft were phased into SAC in 1951, and were retired from that service in 1966.

Manufacturer: Boeing Airplane Company, Seattle, Wash.

Powerplant: Six General Electric Co. J47-GE-25 axial-flow turbojets rated at 7,200 pounds of thrust each with water injection (B-47E).

Dimensions: Wing span, 116 ft.; overall length, 108 ft.; wing area, 1,428 square feet.

Normal gross weight: 206,700 pounds.

Payload: 10,000 pounds of bombs.

Typical performance: Maximum speed, 606 mph. at 16,300 ft. altitude; cruising speed, 557 mph. at 38,500 ft.; ferry range, unrefueled and no bomb load, 4,035 miles.

First flight: December 17, 1947 (XB-47). First deliveries of production aircraft: 1951.

Total built: 2,031 of all types.

SIKORSKY S-55

This design number was given to a series of helicopters that pioneered the use of that class of aircraft in many ways. It will long be remembered for service as a rescue helicopter, hauling thousands of fighting men from exposed positions in the Korean conflict, bringing back wounded and sick, and lifting hundreds of flood victims from disaster-struck areas.

As the HRS-1 and later models, it helped the Marines develop their vertical envelopment tactics. In the Navy as the HO4S-1 series, it became the first helicopter to be used in anti-submarine warfare. The Coast Guard, Army and Air Force all used the S-55 under various designations and for numerous missions. Additionally, it was purchased and widely used for a variety of civilian tasks, ranging from the supply of off-shore oil rigs to passenger and freight-carrying. It was the first helicopter to be used in scheduled passenger services.

Its large payload and roomy fuselage made it ideal for many of these tasks. More than a ton of people or things could be lifted in its capacious belly. The reason for that huge volume grew directly from the design decision to put the engine in the nose. The drive shaft from the engine runs up and aft to the rotor pylon; the two-man crew is seated on each side of the drive shaft, and above the engine level. The space under the pylon

and rotor is free for payload.

The design originated in the late 1940s as the result of Sikorsky experience with the S-51, which had been basically a redesigned R-5 military helicopter. The rotor design ideas of the S-51 were expanded into a new system for the S-55, to be powered by a much larger engine and to be capable of carrying a much greater payload. The S-55 arrived on the scene just in time for use in the Korean conflict, and its place in aviation history is assured by its role in that limited war.

Manufacturer: Sikorsky Aircraft Division of United Aircraft Corp., Bridgeport, Conn.

Powerplant: One Pratt & Whitney R1340-57 air-cooled radial engine rated at 600 horsepower.

Dimensions: Rotor diameter, 53 ft.; overall length of fuselage, 42 ft. 3 in.

Normal gross weight: 7,200 to 7,500 pounds.

Payload: 2,250 pounds.

Typical performance: Maximum speed, 102 mph. at sea level; cruising speed, 85 mph.; range, 460 miles.

First flight: October 11, 1949.

Total built: 1,281, all models.

SIKORSKY S-55: It pioneered in scheduled passenger services.

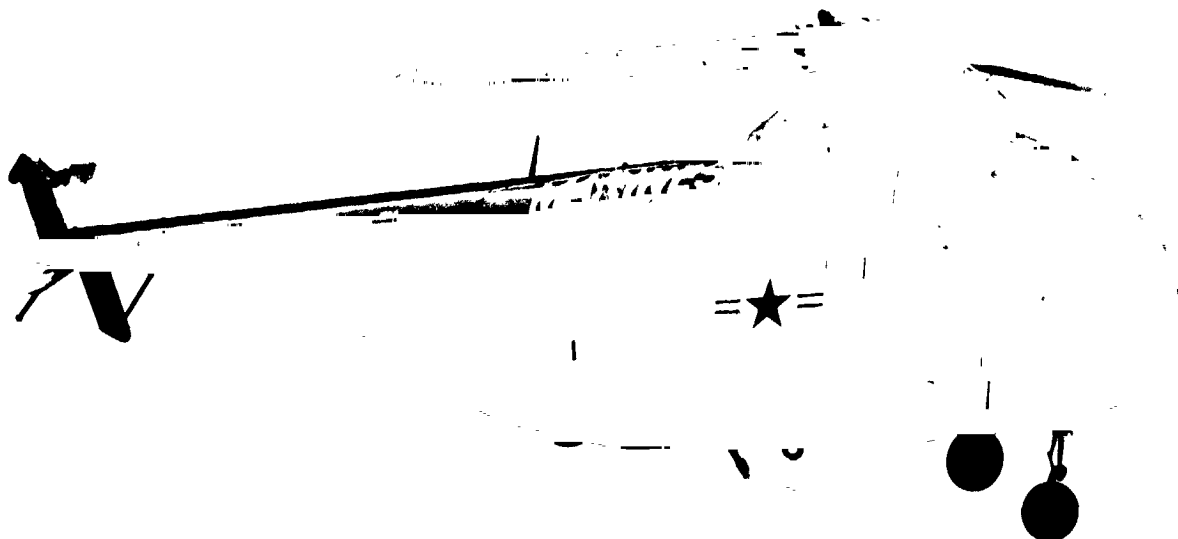

LOCKHEED 1049 "SUPER CONSTELLATION"

The curvaceous "Connie", in its day of glory, represented the peak of first-class airline travel, with quiet and comfortable interiors and speedy, economical performance.

It was the first commercial airliner capable of crossing the Atlantic in both directions, non-stop. The reason: Its wingtip fuel tanks, which added substantially to the range of the production aircraft.

The "Super Constellation" was the next-to-last member of a long-lived family that began with the military C-69 late in 1942. Over the years that followed, the fuselage was stretched, still retaining the dolphin-like shape, and the horsepower was increased. The "Connie" stayed in production for 15 years consecutively, and became a very popular commercial transport, because of its pressurized cabin and its long-range performance.

During its life, it more than doubled its available passenger capacity, increased its gross weight by more than half, and increased its engine power by about the same amount. In the late 1940s, it was again adopted by the military and put to work on a variety of missions, including long-range early-warning duties. A VC-121E "Super Constellation" was used as the presidential aircraft from 1954 to 1961. More recently, the type has

been used for hurricane-hunting, flying repeatedly and deliberately near and through hurricanes to track and report on their course, speed and intensity.

Special modifications have been used for satellite and missile tracking and for geophysical and geomagnetic surveys.

It was ousted from prominence by the new jet airliners that entered service in the late 1950s, and was reduced to carrying freight until replaced in that task also by jet freighters.

Manufacturer: Lockheed Aircraft Corp., Burbank, Calif

Powerplant: Four Wright R3350 Turbo-Compound C18-CA1 or later, rated at 2,800 to 3,250 horsepower.

Dimensions: Wing span, 125 ft. 10 in., overall length, 116 ft. 2 in.; wing area, 1,650 square feet.

Normal gross weight: 137,000 pounds (1049C).

Payload: 71 first-class or 91 coach passengers

Typical performance: Maximum speed, 376 mph.; cruising speed, 305 to 355 mph.; range, 4,620 to 5,840 miles (1049G).

First flight: January 9, 1943 (original C-69); October 13, 1950 (1049); December 12, 1954 (1049G).

Total built: 656 of all models, of which 104 were 1049G types.

LOCKHEED 1049: Long range made "Connie" a popular transport.

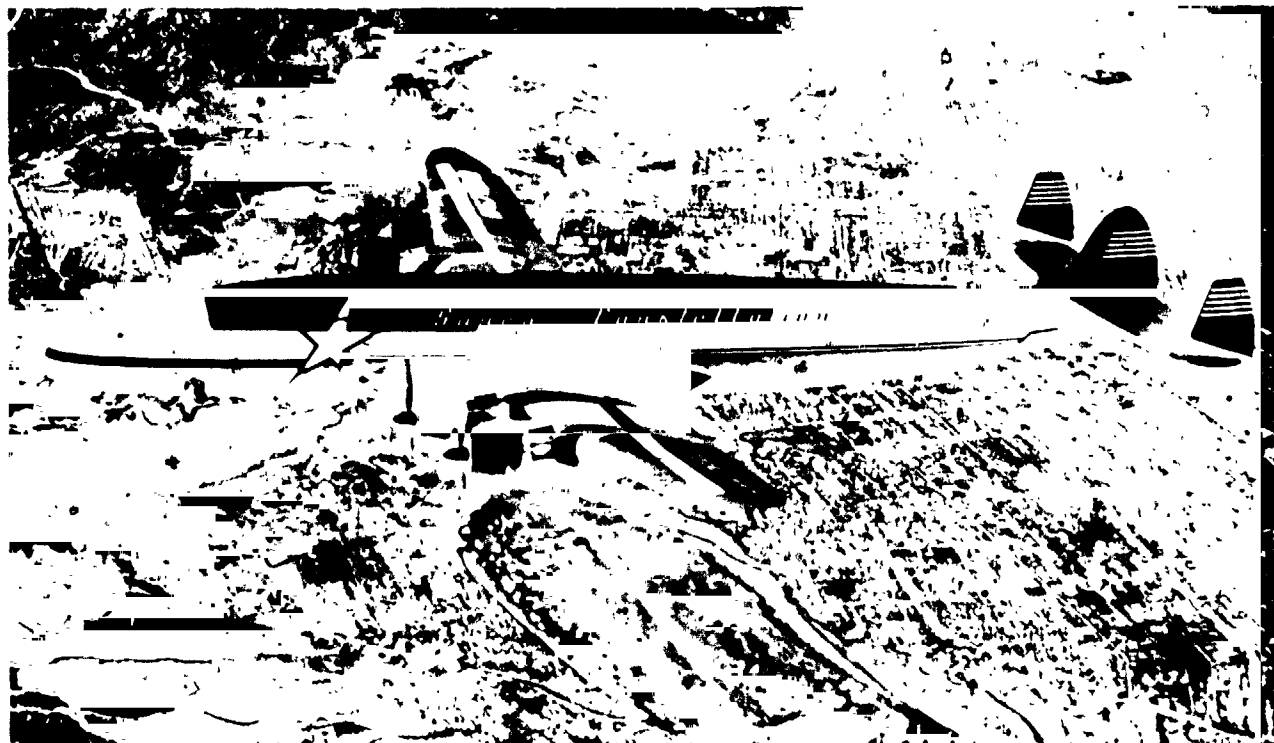



BOEING B-52H: Last of the line, the B-52H set a non-stop world record.

BOEING B-52 "STRATOFORTRESS"

The design studies that led to the XB-52 began less than one year after the end of World War II, to meet an Army Air Force requirement for a very heavy, long-range bomber. Two years later, the studies had focused on an eight-jet design.

In some ways the B-52 design was a natural extension of the innovations of the company's earlier B-47. It retained the thin highspeed airfoils of the B-47, which necessitated the flexible wing design. The B-52 also featured sweepback, bicycle landing gear, podded engines and drogue parachutes. The bicycle landing gear, although wide enough so that the B-52 could stand stably on it alone, was augmented with wingtip outriggers as on the B-47. But one novel feature was added; the B-52 wheel assemblies were made movable so that the wheels could align with the runway in cross-wind landings. In-flight refueling also was adopted as a standard feature from the start of the design.

The defense of the B-52 was to be handled by a single tail turret, fired by a gunner sitting in a tight compartment under the rudder. The bomb bays were huge, designed to house nuclear weapons, and later they were adapted to a variety of bombs, decoys, drones and other stores. The design bomb load was 20,000 pounds, twice that of the B-47.

Although high-altitude delivery of nuclear weapons was the primary design mission, B-52 aircraft have been modified since to enable them to fly low-level missions at high speed.

Latest models of the B-52 are the G and H

versions. The G features a lower vertical tail and additional internal fuel. The tail gunner has been moved into the forward crew compartment with remote firing controls for the tail turret. The H model has entirely new Pratt & Whitney turbofan engines (TF33-P-3, rated at 17,000 pounds of thrust each). A B-52H made an unrefueled flight nonstop from Okinawa to Spain, a distance of 12,519 miles, to set a world record.

Both the G and H models of the B-52 can carry two AGM-28 "Hound Dog" missiles externally in addition to the complete bomb-bay load internally.

Strategic Air Command operates B-52D, G and H models. The planes were phased into SAC starting in 1955; the last was delivered to the Command October 26, 1962.

Manufacturer: Boeing Airplane Company, Seattle, Wash.

Powerplant: Eight Pratt & Whitney J57-P-19W and later models, axial-flow turbojet engines rated at 10,000 pounds of thrust each (B-52A through B-52G).

Dimensions: Wing span, 185 ft.; overall length, 152 ft. 8 in.; wing area, 4,000 square feet.

Normal gross weight: 450,000 pounds.

Armament: 20,000 to 60,000 pounds of bombs, including "Hound Dog" and SRAM missiles and "Quail" decoys.

Typical performance: Maximum speed, 600 mph.; range, approx. 6,000 miles.

First flight: October 2, 1952 (XB-52).

Total built: 744 (all models).

NORTH AMERICAN F-100D "SUPER SABRE"

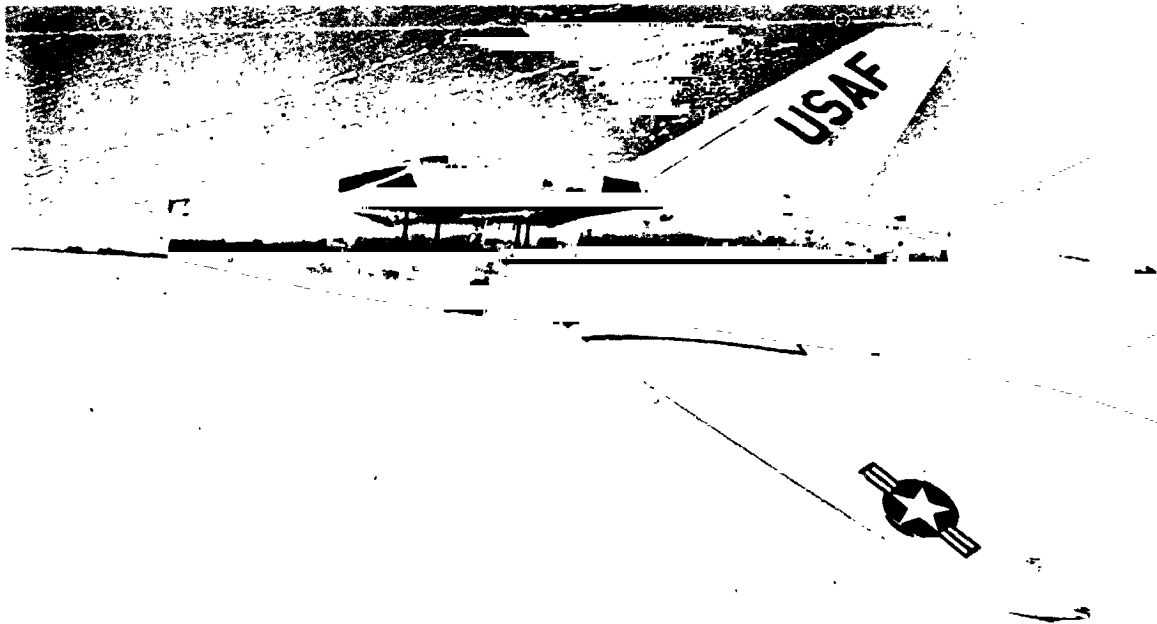

NORTH AMERICAN F-100D: New design features gave birth to the "Super Sabre."

A combination of high wing sweep and a powerful new turbojet engine produced the F-100 series, the world's first supersonic fighter. Other military aircraft before had flown supersonically for a few seconds in a dive; but the F-100 was the first fighter to sustain supersonic speeds in level flight.

The requirement for the F-100 originated in the skies over Korea, where the predecessor "Sabre" had fought for, and won, air superiority. The first approach was to improve the performance of the F-86 by adding a new wing with a 45-degree sweepback. But that early "Sabre 45" design evolved into the YF-100A to meet changing requirements and to take advantage of new aerodynamic data.

Among its features were a low-set horizontal tail to avoid the new problem of pitch-up, a violent maneuver that could destroy an aircraft. The tail was a one-piece "slab" unit, for better supersonic control. Mid-span ailerons were used to eliminate the chance of reversal at high speeds.

The F-100 also helped pioneer the use of titanium metal — chosen for its high strength, heat resistance and lightness — in its airframe.

But like so many pioneering aircraft types, the F-100 had some early problems, and a taller vertical tail, extended wing tips and changes in the control system were necessary to solve them.

The F-100A was the first production version, placed in service as a day fighter. The B model evolved into an entirely different aircraft, the

F-107. The F-100C was designed from the start as a fighter-bomber, and the F-100D had further capabilities in that line, including the ability to deliver nuclear weapons by the LABS (Low-Altitude Bombing System) technique. Additionally, it could serve as a refueling aircraft, using wing tanks equipped with an aerial refueling system. The final model in the series was the two-seat trainer F-100F.

The "Super Sabre" was operated by the Tactical Air Command of USAF, and by the Air National Guard, as well as by several other countries. It was used extensively in Southeast Asia during the war years there.

Manufacturer: North American Aviation, Inc., Inglewood, Calif.

Powerplant: One Pratt & Whitney J57-P-21 or -21A turbojet, rated at 10,200 pounds of thrust or 16,000 pounds of thrust with afterburning.

Dimensions: Wing span, 38 ft. 9.38 in.; overall length, 49 ft. 4 in.; wing area, 400 square feet.

Normal gross weight: 34,050 pounds.

Armament: Four M-39E 20-mm. cannon, plus missiles or bombs up to 6,000 pounds.

Typical performance: Maximum speed, 910 mph. at 35,000 feet; cruising speed, 590 mph.; combat radius, 534 miles.

First flight: May 25, 1953 (YF-100A)

Total built: 2,294, including 2 YF-100A, 203 F-100A, 476 F-100C, 1,274 F-100D, and 339 F-100F.

BOEING MODEL 367-80

This prototype jet transport, forerunner of the famed Boeing 707 line, was the first step toward U. S. leadership in commercial jet transports. It was privately financed and developed by Boeing as a jet transport and tanker prototype, with the dual aim of contracts for the commercial version and for an Air Force tanker, then in the requirement stage.

Boeing won both, and the rest of the story is a major part of aeronautical history.

The "Dash Eighty", as the prototype has always been called, was used first to develop the ideas and flight techniques of jet transports. Loaded with test equipment and its usual crew of three, the "Dash Eighty" explored every corner of the jet flight regime. During its lifetime, it was modified, re-engined, and repaired many times.

It tested strange radome shapes on its nose, and an aerial refueling system on its tail. For one program, it flew with five engines instead of its usual four.

Unofficially, of course, it was barrel-rolled by its exuberant test pilots. It plowed through soft-field landings, flew very close to the speed of sound, and — in an exciting NASA flight research program — showed its capability of flying straight and level at only 75 miles per hour near the ground.

Its design go-ahead came in May 1952, and by November, parts were being built. After the first flight came the first orders: Late in 1954, the Air Force bought it, as the KC-135 jet tanker/transport. One year later, the airlines started their ordering, and the process has — at mid-1974 — not yet stopped.

The "Dash Eighty", after 18 years of rugged developmental flying, was ferried in 1972 to Washington, D. C., and a permanent place in the National Air and Space Museum.

Manufacturer: Boeing Airplane Company, Seattle, Wash.

Powerplant: Four Pratt & Whitney JT3 axial-flow turbojet engines rated at 10,000 pounds of thrust each.

Dimensions: Wing span, 129 ft. 8 in.; overall length, 127 ft. 10 in.; wing area, 2,400 square feet.

Normal gross weight: 190,000 pounds.

Payload: Test equipment only.

Typical performance: Maximum speed, 582 mph. at 120,000 pounds weight and 25,000 feet; cruising speed, 550 mph.; range, 3,530 miles with reserves.

First flight: July 15, 1954.

Total built: One (Dash Eighty); more than 890 Model 707 and 720 aircraft; 743 in the KC-135 series.

BOEING 367-80: This prototype helped the U. S. lead in jet transports.

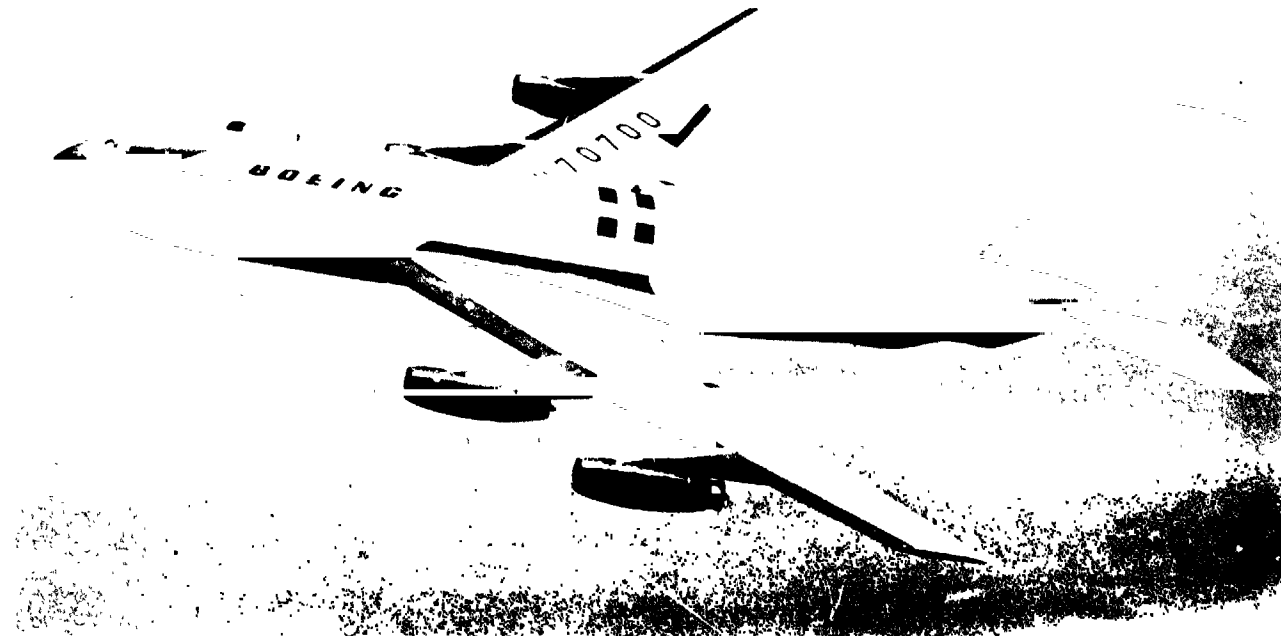

VOUGHT F-8E "CRUSADER"

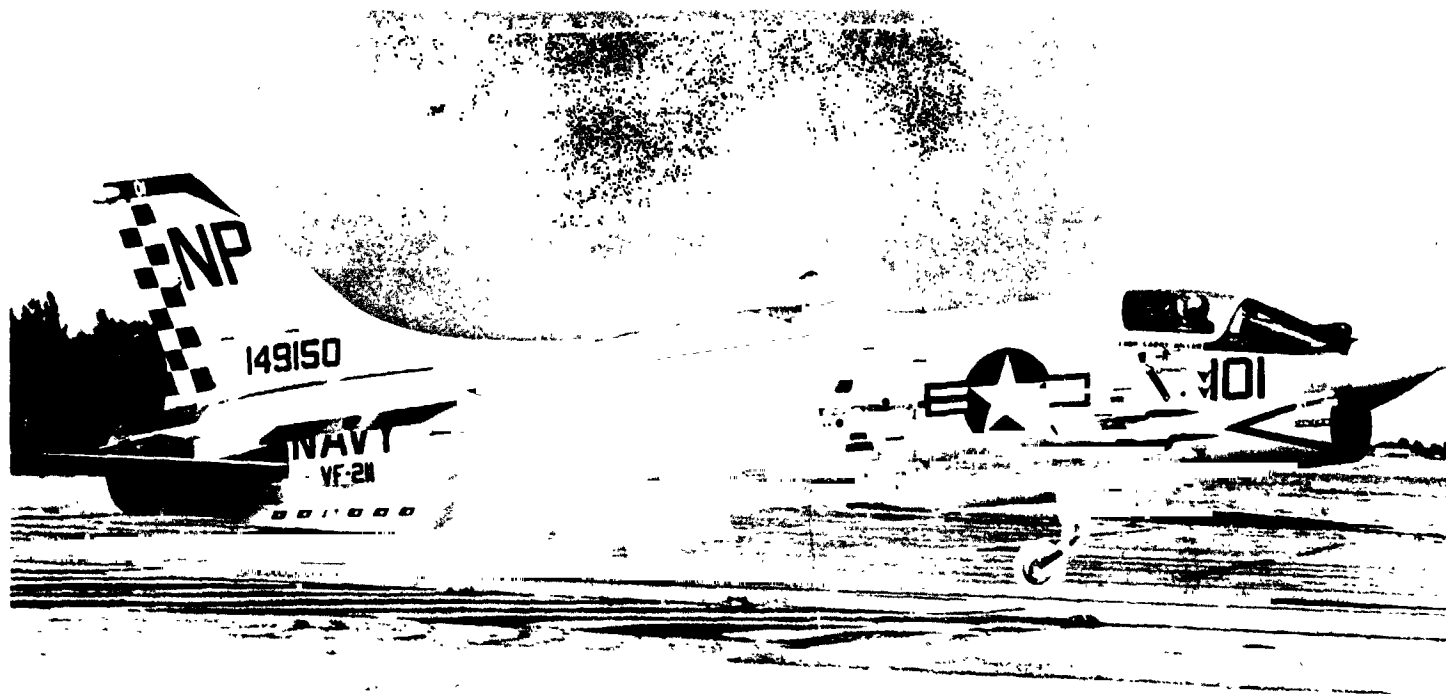

VOUGHT F-8E: The area rule reduced the "Crusader" transonic drag.

It was the first carrier-based fighter to exceed 1,000 mph., a feat which won for its developers the Collier Trophy in 1956. It was also the first airplane to fly across the United States at supersonic speed all the way; the pilot was then a relatively obscure Marine Corps Major named John H. Glenn.

The "Crusader" had to combine searing speed with tractability for carrier operations. Two design innovations made this possible. The first was the area rule, an aerodynamic development by the NACA, which greatly reduced the transonic drag of the airplane. The second was the variable-incidence wing, mounted so that its entire leading edge could be raised. This developed high lift while the fuselage remained almost level, giving the pilot superb forward visibility for the approach and landing on the aircraft carrier.

The Navy issued its requirement in the Fall of 1952, based on some of its experience in the Korean conflict. The need was for a day fighter with supersonic speed; Vought won the competition with its design for the F8U-1 (later redesignated F-8). On its first flight, it slammed through the speed of sound, and verified its designers' claims for highspeed performance.

Little more than a year after the first flight of the prototype, the Navy accepted the first production aircraft, with carrier qualifications and other service testing behind it. Five different

models, each improved basically over the one before it, followed each other down the "Crusader" production line. One specialized version was a high-speed photo-reconnaissance aircraft; another was built for the French Navy, featuring wing flaps that were "blown" by the excess air from the engine compressor to increase further the lift for landing.

The "Crusader" equipped about half of the Navy and Marine Corps fighter squadrons at the height of its service life. It fought well and ably in the Southeast Asia theater of war.

Manufacturer: Chance Vought Aircraft, Inc., Dallas, Texas.

Powerplant: One Pratt & Whitney J57-P-20 turbojet rated at 10,700 pounds of thrust, or 18,000 pounds with afterburning.

Dimensions: Wing span, 35 ft. 8 in.; overall length, 54 ft. 2 in.; wing area, 350 square feet.

Normal gross weight: 28,000 pounds without external loads (F-8E).

Armament: Four 20-mm. cannon and four AIM-98 "Sidewinder" air-to-air missiles, plus bombs, rockets or missiles up to 4,000 pounds.

Typical performance: Maximum speed, Mach 1.5; combat radius, about 600 miles.

First flight: March 25, 1955 (XF8U-1).

Total built: 1,264, all models.

BELL MODEL 204

This versatile, single-engined, single-rotor helicopter series, of which the Model 204B is the civilian version, has been built in greater numbers than any other rotary-wing aircraft. It originated as the XH-40, a utility helicopter prototype developed for the Army, and has grown through several production changes and design modifications which have greatly increased both its gross weight and its horsepower.

The XH-40 prototype carried six persons and weighed 5,650 pounds; the 204B carries ten persons and weighs 8,500 pounds in that configuration.

In its military version, it was the world's first armed helicopter, and — in that tactical configuration and others — it serves with the U. S. Army, Marine Corps and Air Force. Twenty nations use various models of this helicopter for such tasks as utility and training, medical evacuation, cargo transport and battlefield tactical missions.

It is familiarly known as the "Huey" in its military forms, because of an earlier military designation of HU-1 (now redesignated UH-1). Several models are in service, including the UH-1B, UH-1C, UH-1D, and the UH-1H.

Engine development and rotor size increases have paced the growth of the series. The prototype XH-40 swung a 44-foot diameter rotor, and was powered by a single Lycoming XT53 engine rated at about 825 horsepower. The last version of the 204B had a 48-foot rotor diameter with wider-chord blades, and was powered by the Lycoming commercial equivalent of an advanced T53 developing 1,100 horsepower. Initial capacity was six seats; the late models will carry ten, or more, persons.

Manufacturer: Bell Helicopter Company, Ft. Worth, Tex.

Powerplant: One Lycoming LTC1K-2 shaft turbine rated at 1,100 shaft horsepower (civil version of the T53-L-9 shaft turbine engine).

Dimensions: Rotor diameter, 48 ft.; overall length, 57 ft.

Normal gross weight: 8,500 pounds; corresponding useful load, 4,182 pounds.

Typical performance: Cruising speed at sea level and 8,500 pounds, 121 mph.

First flight: October 22, 1956 (XH-40 prototype); first production 204B delivered: April 1963.

Total built: Nearly 10,500 at mid-1974, all models.

BELL 204: A utility design, it led to the production of thousands.



CONVAIR B-58A "HUSTLER"

It was the first — and for many years, the only — supersonic bomber in the world, capable of flying in the target area at twice the speed of sound. It was ordered as the first "weapons system", which means that its airframe, engines, bombs, support equipment and the like were, to a large extent, designed and developed simultaneously for this single program.

Its large delta wing was built primarily from sandwich panels, huge sheets of thin skin bonded to a honeycomb core. The structure was very light, and rugged. It had an area-ruled shape — a major assist by the NACA — to minimize the transonic drag. The three-man crew was seated in tandem. At the tail was a rearward-firing Gatling-type cannon. Under the fuselage was a streamlined pod which housed fuel, weapons, electronic countermeasures, or reconnaissance equipment.

The B-58 stemmed from a design competition in 1949, which was won by Consolidated-Vultee Aircraft Corp. Thirty were ordered for test and evaluation, as part of the weapons system concept. After that phase, and a transition training period, the first B-58 wing was activated with Strategic Air Command on March 15, 1960.

One high point of the B-58's operational career was a record-making flight from Tokyo to London, flown non-stop at supersonic speeds. Three B-58As

from the 305th Bomb Wing began the flight from Okinawa, crossed above the starting gate at Tokyo and headed for London. One dropped out with navigation systems trouble, the second was ordered back via Chicago, and the third continued to London, covering the 8,028 miles in eight hours and 35 minutes.

The B-58s were phased out of SAC in January, 1970.

Manufacturer: General Dynamics Corp., Convair Division, Forth Worth, Texas.

Powerplant: Four General Electric J79-GE-5B turbojets, each rated at 15,600 pounds of thrust with afterburning for takeoff.

Dimensions: Wing span, 56 ft. 10 in.; overall length, 96 ft. 9 in.; wing area, 1,542 square feet.

Normal gross weight: About 160,000 pounds.

Armament: Podded weapons; rearward-firing Vulcan M-61 20-mm. cannon.

Typical performance: Sustained dash speed of Mach 2.0⁺, or, characteristically, 1,385 mph. at 44,000 feet; cruising speed, 595 mph.; tactical radius, 1,200 miles.

First flight: November 11, 1956.

Total built: 30 pre-production for test and evaluation plus 86 production aircraft for a total of 116.

CONVAIR B-58A: It flew, non-stop Tokyo to London, at supersonic speed.

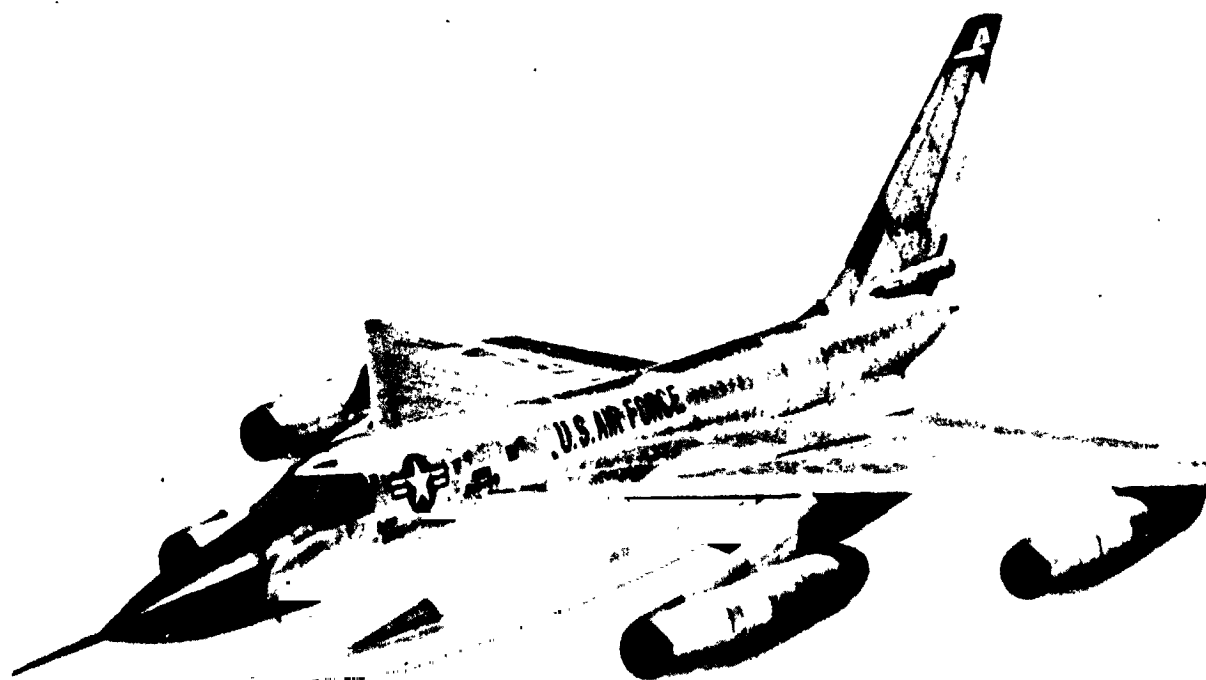

CONVAIR F-106A "DELTA DART"

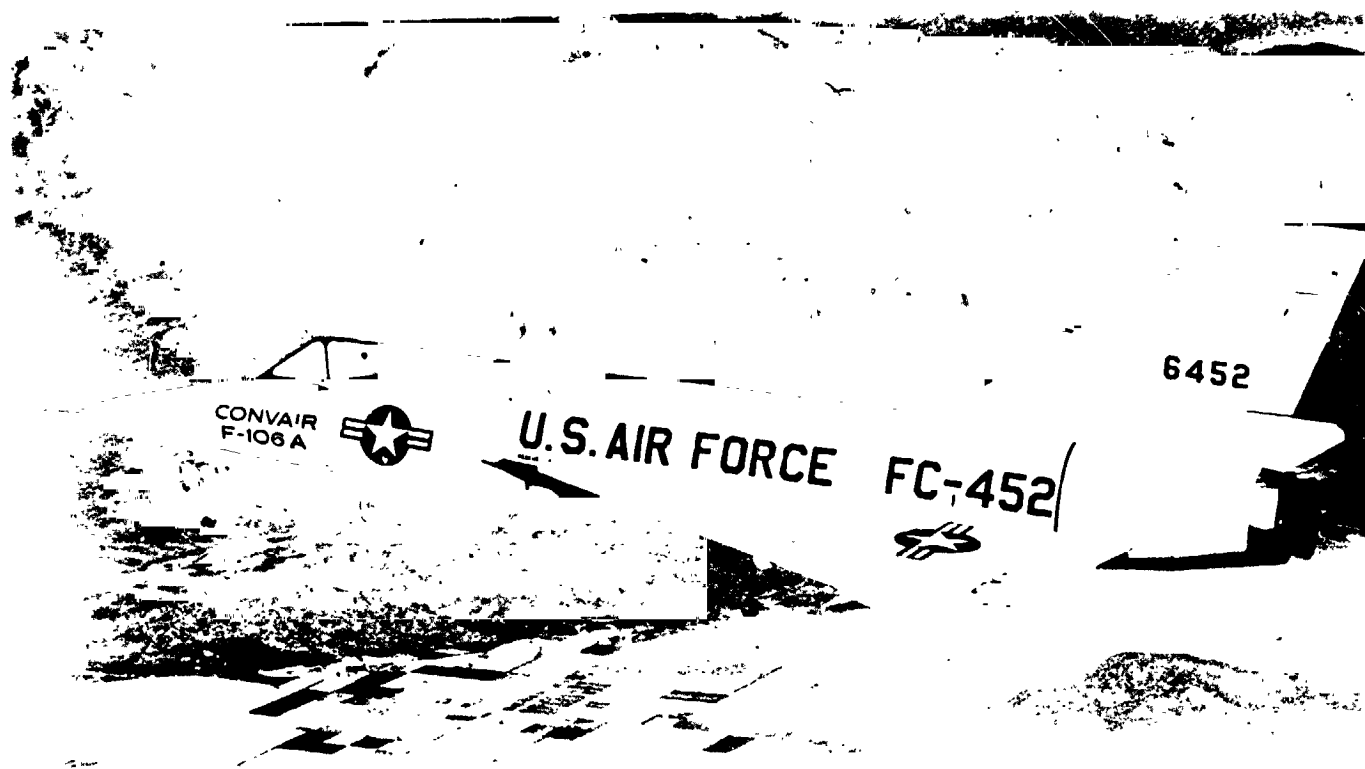

CONVAIR F-106A: The pilot is along for the ride in this automatic interceptor.

The F-106A, the current standard U. S. interceptor aircraft, is an automatically guided and fired weapon system in which the pilot is a monitor of advanced electronic systems. Among its design features are its delta wing and its area-ruled fuselage.

The "Delta Dart" started life in 1955, as a development of the earlier F-102 interceptor of similar layout, but it quickly became a complete new model. Its electronic brain is a digital computer, which receives and processes position data from targets and from a ground controller. The F-106 is directed automatically to the area of its target by ground commands; its radar automatically detects, tracks, and locks on to the target, and at the proper instant, the "Delta Dart" fires its missiles.

The basic design has been modified and updated several times since its inception, particularly in its electronics equipment. Changes in airborne electronics technology have offered major improvements in performance in less space or lighter weights, and — even though the F-106 now is a design approaching the 20-year-old mark — it is as contemporary electronically as many newer aircraft.

F-106s originally were assigned to the Air Defense Command; but recently, as that Command

has been reduced in size and scope, the "Delta Dart" has been transferred to Air National Guard units in various states. In those organizations, they maintain operational readiness status as part of the air defense system of the United States.

Early in 1974, about 200 F-106 aircraft were in service, 14 years after they first entered squadrons of the Air Defense Command.

Manufacturer: General Dynamics Corp., Convair Division, San Diego, Calif.

Powerplant: One Pratt & Whitney J75-P-17 turbojet, rated at 24,500 pounds of thrust with afterburner for takeoff.

Dimensions: Wing span, 38 ft. 3 in.; overall length, 70 ft. 9 in.; wing area, 697.8 square feet.

Normal gross weight: 35,500 pounds.

Armament: "Genie" or "Falcon" air-to-air missiles.

Typical performance: Maximum speed, Mach 2.0+; tactical radius, about 600 mi.; can attack targets as high as 70,000 feet in a zoom climb.

First flight: December 26, 1956.

Total built: 257 F-106A; 63 F-106B (two-seat trainer).

VERTOL CH-46A "SEA KNIGHT"

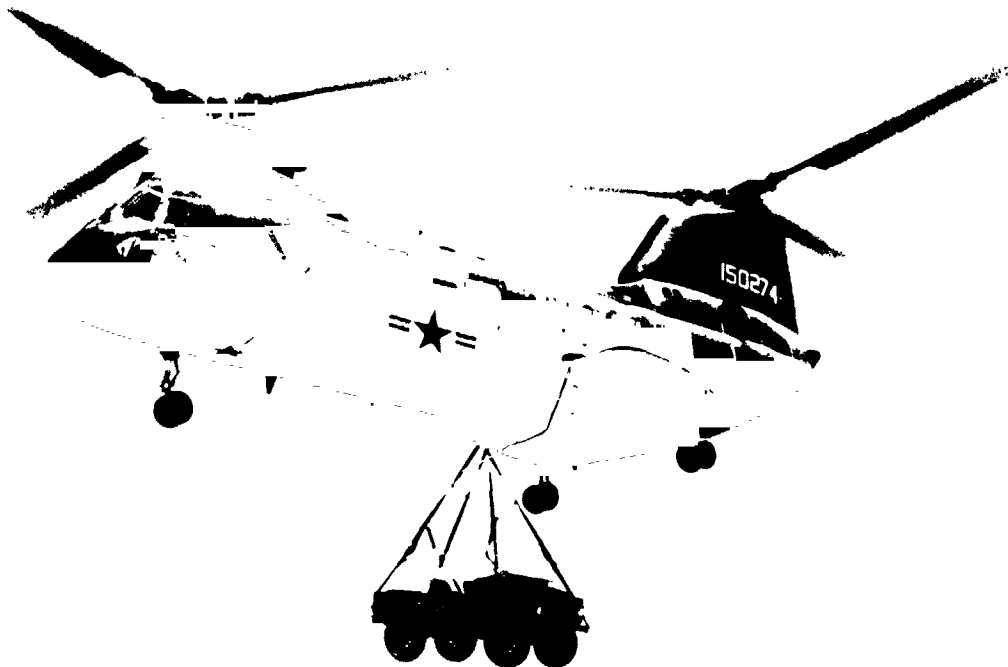

VERTOL CH-46A: The "Sea Knight" was designed to move USMC combat elements.

This tandem-rotored helicopter has been serving with the United States Navy and Marine Corps, helping to pioneer the tactics of vertical replenishment (for the Navy) and of vertical envelopment (for the Marines).

It originated as the Vertol 107, a commercial design used for several years in passenger-carrying services. But the tandem-rotor concept goes back to the first work done by Frank Piasecki with a variety of test aircraft and the famous H-21 "flying banana" used during the early 1950s.

The design concept moves the rotors fore and aft to make a large center-section cabin available. The helicopter then is relatively insensitive to major changes in loading and center of gravity position.

The major purpose in the design was to provide a means of moving combat elements of the Marines from any class of Navy carrier to positions beyond the beachhead. Combat teams landed there can advance toward the beach in a pincer movement with other combat teams landed by boat on the beachhead.

Additionally, the helicopters were to be used to supply equipment and other needs in cargo deliveries to the troops.

Officially classed as a medium-assault helicopter, the "Sea Knight" has both all-weather and shipboard capabilities. Its rear ramp speeds the

loading and unloading of cargo and troops, while an external cargo hook allows the helicopter to carry loads slung underneath its fuselage. It can also land on the water, its sealed fuselage giving it this amphibious capability.

The CH-46A design is used by the Canadian Army and the Royal Swedish Navy and Air Force, in addition to the U. S. Navy and Marines. It also is manufactured under license by Kawasaki Aircraft of Japan.

Manufacturer: Vertol Division of the Boeing Company, Morton, Pa.

Powerplant: Two General Electric T58-GE-8 shaft turbines rated at 1,250 horsepower each.

Dimensions: Rotor diameter, 50 ft; overall length, tip to tip of rotors, 83 ft. 4 in.

Normal gross weight: 19,431 pounds for assault missions.

Payload: Three crew plus 4,000 pounds load, equal to 25 troops, or to 15 litter patients and two attendants.

Typical performance: Maximum speed, 155 mph.; cruising speed, 150 mph.; radius of action, 115 miles.

First flight: October 16, 1962 (CH-46A).

Total built: 624.

McDONNELL F-4B "PHANTOM II"

This versatile aircraft is the mainstay of U. S. Air Force, Navy and Marine Corps fighter squadrons. During its continuing service in the military, it has established 15 world records for speed and time to climb. It has been in continuous production since August 1956. It also serves in the air forces of Great Britain, Germany, Iran and Israel.

The "Phantom II" originated as a McDonnell design proposal for a single-seat fighter built around two Curtiss-Wright J65 turbojets. Soon after, McDonnell aimed its proposal at a Navy requirement of September 1953, calling for a long-range attack fighter. About one year later, the company received a contract for two prototypes; production aircraft were to be called the AH-1, and to be powered by paired General Electric J79 turbojets.

For almost a year the requirements continued to change, and the AH-1 design was changed to keep up. The single-place concept changed to the two-man crew now standard. The wings were cranked, the tail was bent downward, missiles became the major weapons, ornate electronic systems were added for fire-control and other complex tasks. "Blown" wing flaps, their lift augmented by blasts of engine air over their leading edges, were added on an early prototype.

Redesignated the F4H-1, the "Phantom II" was ordered in quantity following the winning of a 1958 "fly-off" competition against the Vought F8U-3 "Crusader III." It was again redesignated to become the F-4A.

First of the operational models was the F-4B,

which joined the fleet in 1961. All the production run went to the Navy and the Marines. Later, the F-4C was developed for the Air Force, and that service further developed the aircraft into the F-4D and F-4E models, the latter the first model to be equipped with a cannon as well as missiles for offense.

Later models include the F-4G for automatic carrier landing test work; the F-4J, latest combat aircraft for the Navy and Marines; the F-4K and F-4M for Great Britain's Royal Navy and Royal Air Force. Iran operates modified F-4D models; the Israelis use F-4E versions, and the Germans fly RF-4E models.

Manufacturer: McDonnell Aircraft Corp., St. Louis, Mo.

Powerplant: Two General Electric J79-GE-8 turbojets, each rated at 17,000 pounds thrust with afterburning.

Dimensions: Wing span, 38 ft. 5 in.; overall length, 58 ft. 3 in.; wing area, 530 square feet.

Normal gross weight: 54,600 pounds (typical, with external stores).

Armament: Up to eight tons of bombs, rockets, and other weapons on hard points under the wings; "Sparrow" missiles.

Typical performance: Maximum speed, Mach 2.25 at 48,000 feet; combat radius as interceptor, about 900 miles; combat radius as attack aircraft, about 1,000 miles.

First flight: May 27, 1958 (XF4H-1).

Total built: More than 4,500 at mid-1974.

McDONNELL F-4B:
It was the first of many
for all three services.



DOUGLAS DC-8

Handicapped by a late start, the Douglas DC-8 never did catch up with the Boeing 707 jet transport. When Douglas shut down the production line, the company had built about 60 percent as many four jet transports as its competition in Seattle. And yet the Douglas DC-8 deserves a place among significant U. S. aircraft, if for no other reason than the fact that it is a high-quality product from a respected company.

The first DC-8 flew only a few months before the first 707 entered commercial service. Despite the time lag, the DC-8 sold well initially, and the aircraft was developed through a series of models which had variations in capacity and performance.

They were comfortable for the traveler, somewhat quieter than their competition — although the point will be argued — and well liked by most of the airlines that operated them.

The DC-8 was — so far as is known — the first commercial jet transport to have exceeded the speed of sound. It was deliberately dived during its test program, and passed through Mach 1 without a tremor.

The culmination of the DC-8 development was the Super Sixty series, with fuselages that were stretched to hold more than 250 passengers. They

remained the largest-capacity passenger aircraft in service until the wide-bodied jets began to arrive some years later.

Many DC-8s are in service today with scheduled airlines, but they are being replaced with newer equipment that is more versatile and larger

Manufacturer: Douglas Aircraft Company, Long Beach, Calif.

Powerplant: Four Pratt & Whitney JT3C turbojets rated at 13,500 pounds of thrust (early models); later aircraft had turbofan engines, rated up to 19,000 pounds thrust.

Dimensions: Wing span, 142 ft. 4.3 in.; overall length, 150 ft. 6.4 inches (early models), 187 ft. 5 in. (Super Sixty); wing area, 2,758 square feet.

Normal gross weight: 265,000 pounds (Series 10); 350,000 pounds (Super 63).

Payload: 116 to 259 passengers.

Typical performance: Maximum speed, 600 mph.; cruising speed, 544 to 583 mph.; range, 3,700 miles (early models) to 8,720 miles.

First flight: May 30, 1958.

Total built: 556, all models.

DOUGLAS DC-8: The "Pacific Pacer" was the prototype DC-8 jet transport.

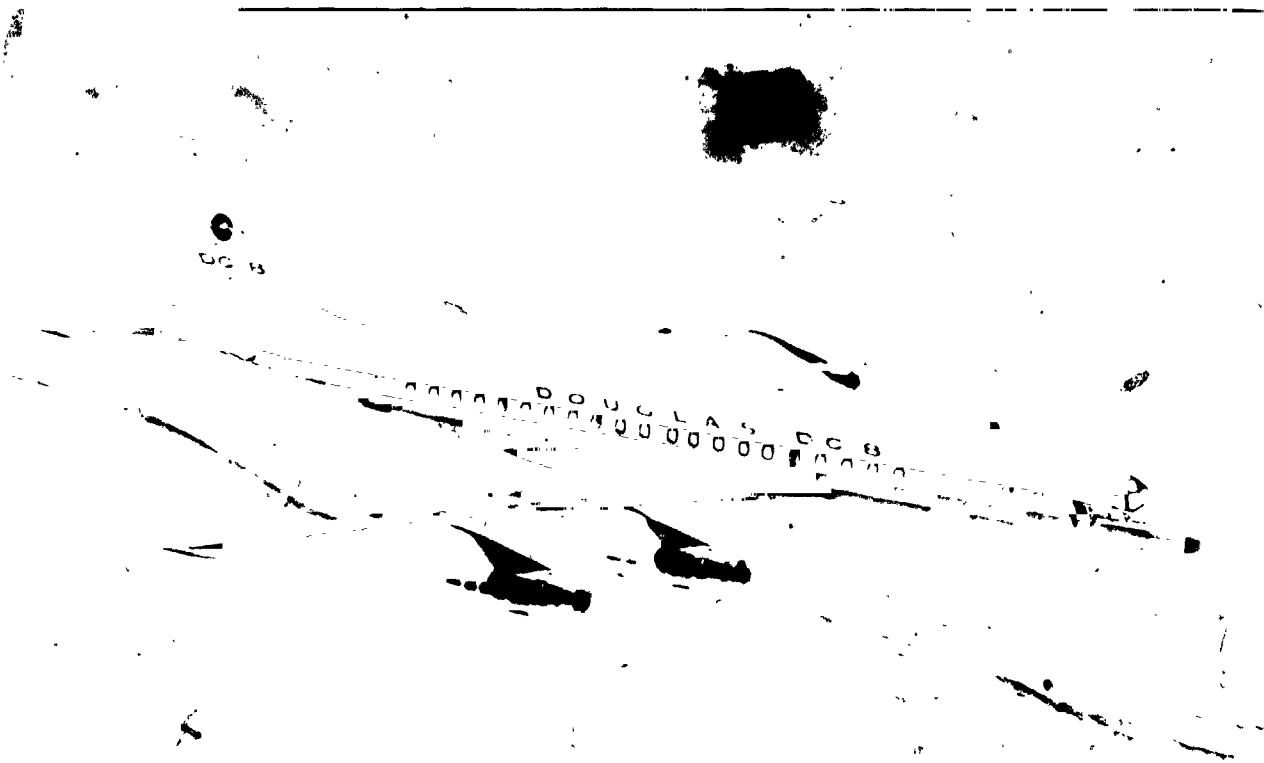

NORTH AMERICAN X-15

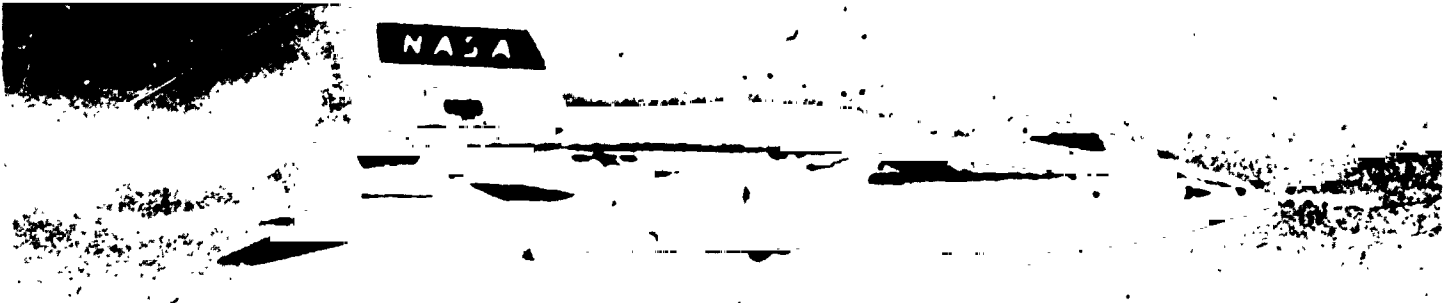

NORTH AMERICAN X-15: Specialized for research, it advanced man's knowledge of flight.

It was a highly successful research aircraft and, during its life, furnished fundamental engineering and scientific information of value to many aeronautical and space programs.

The basic concept was to provide a research aircraft that could probe new regions of speed and altitude, reaching six times the speed of sound in level flight, and heights that would only be exceeded by later space flights. Before the program ended, the X-15 had been flown to an altitude of 354,200 feet, more than 67 miles above the Earth's surface. It had exceeded its speed objectives, reaching Mach 6.7 on one test flight of the second X-15 aircraft. And in its investigation of high-temperature phenomena, it had flown fast enough in air dense enough to produce temperatures above 1,300°F, hot enough to turn large areas of its structure a cherry-red color.

It provided basic knowledge of hypersonic flight, a new regime of performance where conventional controls and test data no longer applied. The X-15 control system became the basis for the reaction controls on the Mercury and Gemini spacecraft. The pilot's flying suits developed for the X-15 program evolved easily into the spacesuits for the Mercury and Gemini astronauts.

The high temperatures anticipated in the flight

regime of the X-15 led to the extensive structural use of titanium and Inconel-X, and the lessons learned from fabricating those two metals paid off in machining and production techniques for all of the aerospace industry.

For nine productive years, the three X-15 models flew in a cooperative flight research program under NASA and the Air Force. They opened new frontiers of flight, and they extended man's knowledge.

Manufacturer: North American Aviation, Inc., Inglewood, Calif.

Powerplant: One Reaction Motors, Inc., XLR-99 rocket engine producing 57,000 pounds of thrust.

Dimensions: Wing span, 22 ft. 7 in.; overall length, 50 ft. (X-15-1); wing area, 200 square feet.

Normal gross weight: 33,000 pounds (X-15-1); 53,000 pounds (X-15-2).

Payload: Scientific instrumentation.

Maximum performance: Mach 6.72 (4,534 mph.); altitude, 354,200 feet.

First flight: June 8, 1959 (unpowered glide); September 17, 1959 (powered, interim engine); November 15, 1960 (powered, final engine).

Total built: Three.

PIPER "CHEROKEE 140"

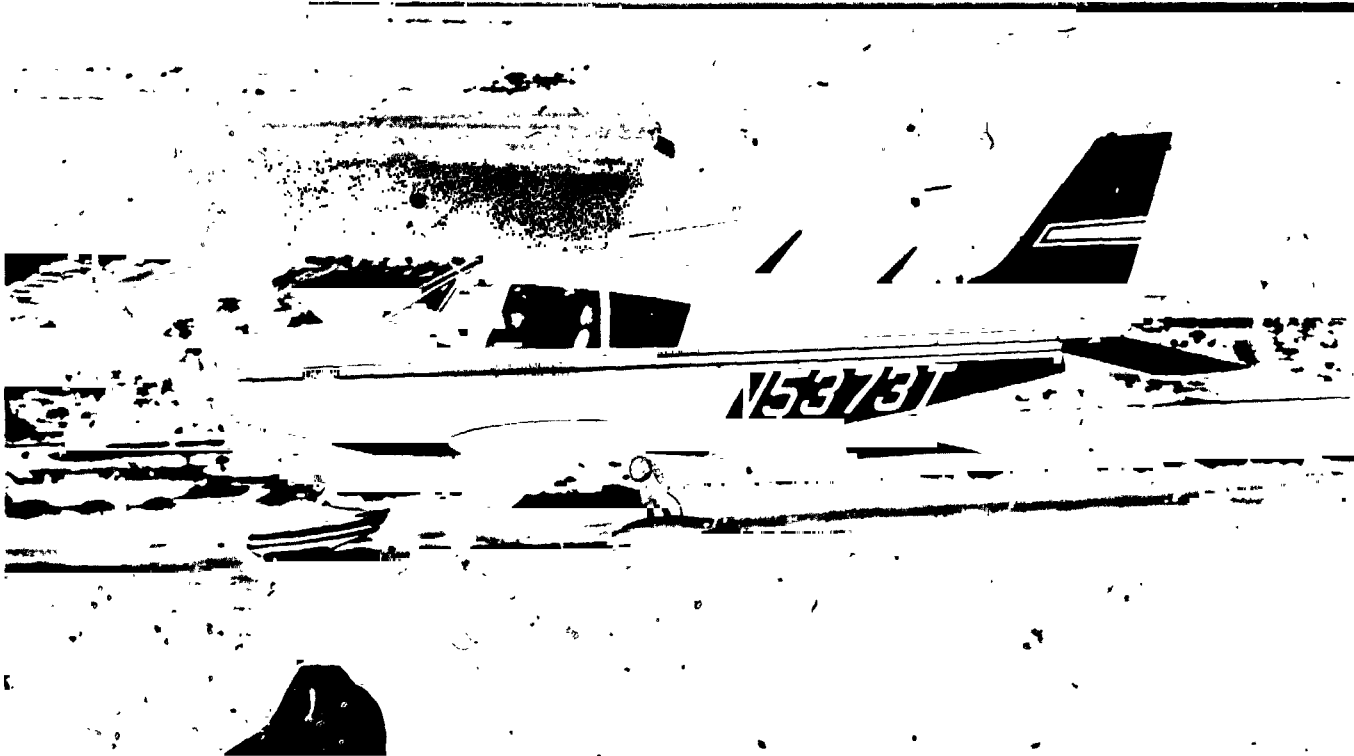

PIPER "CHEROKEE 140": This sport plane and its factory were designed together.

This low-winged, all-metal sport aircraft is the lowest-cost member of a complete family of Piper planes carrying the "Cherokee" name. From this two-seat version, most popular as a training and sport plane, the line extends upward through four-seat versions with increased power and performance, to the top-of-the-line six-to-seven place version that can double as an air taxi or a corporate business aircraft.

The "Cherokee 140" is representative of the current generation of light general-aviation aircraft. But it has one unusual characteristic.

It is perhaps the only example of simultaneous design of an airplane and a factory to produce it. The mandate was to develop a simple, low-cost family tourer. The market looked tremendous, and the Piper factory capacity at Lock Haven, Pa., was about out of expansion space. A new site at Vero Beach, Florida, was chosen and the world's first mass-production center for light aircraft was designed in parallel with the first "Cherokee."

The "Cherokee" got into the air before the factory was finished, but production followed rapidly. During the first year, more than 600 "Cherokees" were built and flown. In five years, 6,000 had been produced, and they were rolling off the Vero Beach assembly lines at the rate of

nearly a dozen per working day.

Mass production techniques resulted in efficient and low-cost construction. A few years back, after the plant had hit its stride, the output of aircraft was at the rate of nearly two per worker per year, a phenomenal figure for a light aircraft.

It's a popular plane, and perhaps one British pilot described it best: "... the Piper "Cherokee" family is regarded with the affection that an Englishman normally reserves for his dog. "Cherokees" are generally docile and well-mannered but always ready for a romp if the weather should be particularly tempting."

Manufacturer: Piper Aircraft Corp., Vero Beach, Florida.

Powerplant: One Lycoming O320-2AB air-cooled engine rated at 140 horsepower.

Dimensions: Wing span, 30 ft.; overall length, 23 ft. 4 in.; wing area, 160 square feet.

Normal gross weight: 1,950 pounds.

Useful load: Pilot, passenger and baggage.

Typical performance: Maximum speed, 144 mph.; cruising speed, 134 mph.; range, 560 miles.

First flight: January 14, 1960.

SIKORSKY S-64

This huge flying crane is the country's biggest helicopter, and it is able to lift a useful load greater than its own empty weight.

The goal was to develop a helicopter that would do for air transportation what the trailer truck did for over-the-road transportation. Sikorsky designed a twin-engined lifting rotor system, with a standard cockpit forward and a vestigial cockpit below and facing aft. That latter position is used when the helicopter is lifting a large load; the direct observation of the hoisting process by the pilot makes for better coordination.

To the lifting rotor, the designers added widespread landing gear that could straddle large loads for easier pickup. Consequently, the various versions of the S-64 can handle individual cargos or special vans with equal ease.

Earlier Sikorsky designs contributed to the development of the S-64. The six-bladed rotor system came essentially intact from the twin-engined S-56. Much design and flight experience came from the S-60 program, a predecessor flying crane powered by piston engines.

The original specification was developed by the Army of the Federal Republic of Germany for a heavy-lift helicopter capable of hauling ten tons vertically. Deliveries have been made to the German Army, and to the U. S. Army, which employed the CH-54A (its military designation) in the Southeast Asian theater of war. There it has been used to retrieve other helicopters from crash sites, to airlift downed aircraft, to carry earthmovers and other heavy equipment to mountain tops, and to move heavy artillery quickly from one position to another.

Manufacturer: Sikorsky Aircraft Division of United Aircraft Corp., Stratford, Conn.

Powerplant: Two Pratt & Whitney JFTD12-5A shaft turbines each rated at 4,800 horsepower maximum (S-64F).

Dimensions: Rotor diameter, 72 ft.; fuselage length, 70 ft. 3 in.

Normal gross weight: 47,000 pounds (S-64F).

Payload: 25,000 pounds (S-64F).

Typical performance: Maximum speed with external load drag equivalent to 129 square feet, 118 mph.; cruising speed, same conditions, 110 mph.; range, same conditions, 170 miles.

First flight: May 9, 1962 (first prototype).

Total built: 103.

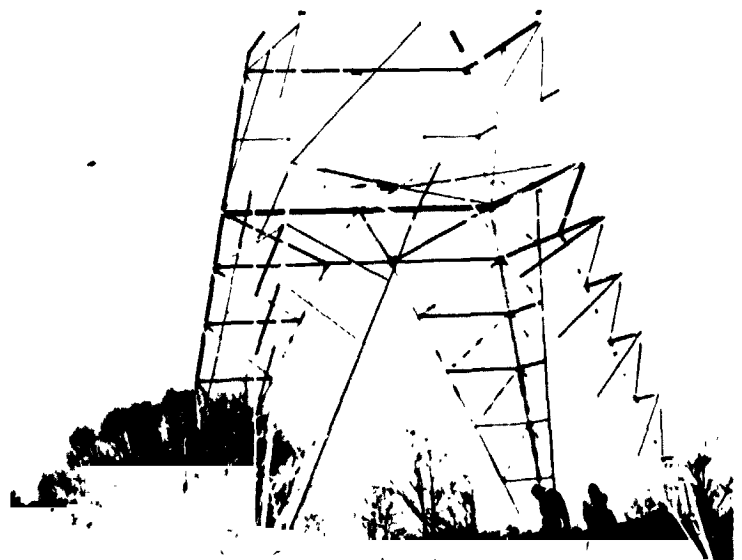
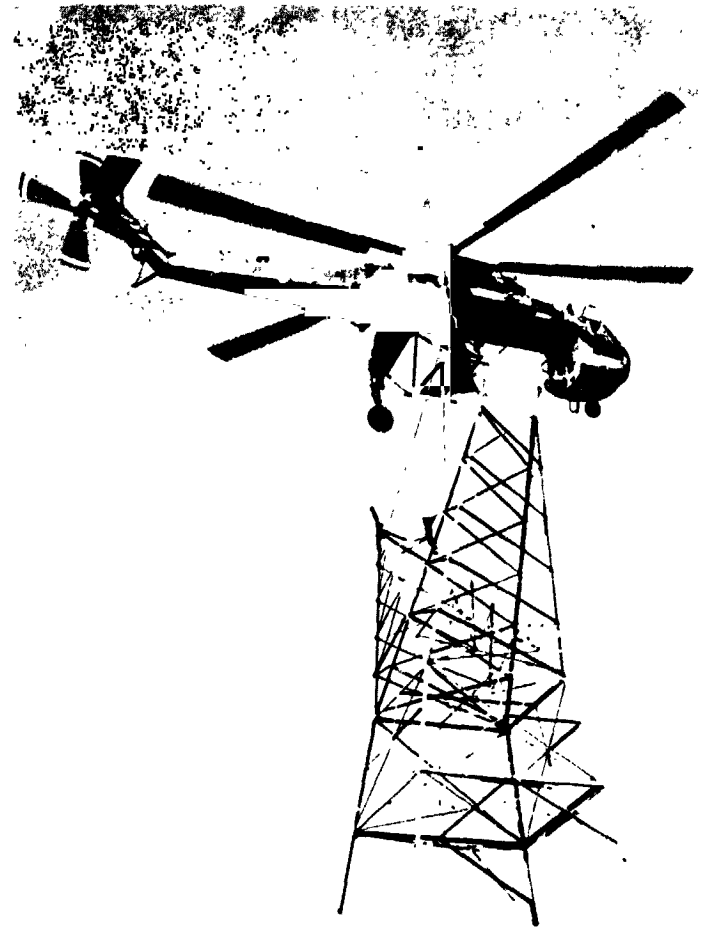

SIKORSKY S-64:
It can lift loads greater than its own weight.

BOEING MODEL 727

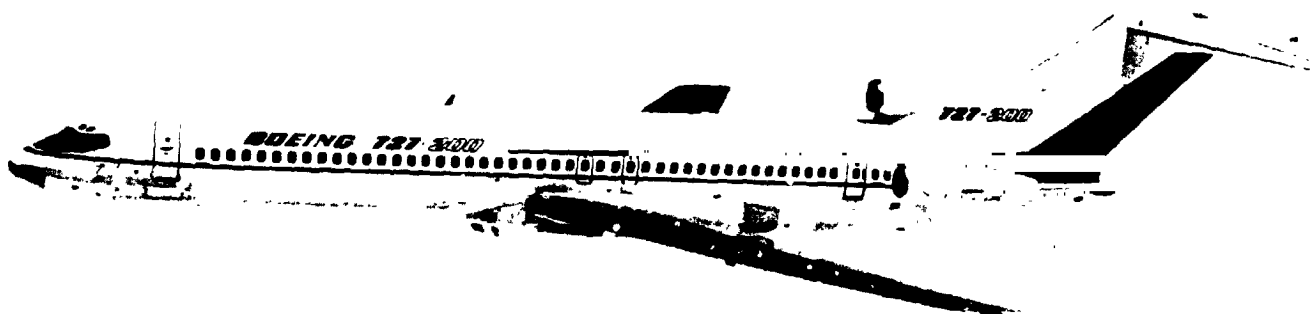

BOEING 727: A high-lift system helps make this transport successful.

Boeing's second jet transport development was aimed at shorter ranges and smaller airports. The same design philosophy produced the Boeing 727, a jet-powered transport with a wing full of high-lift devices. That wing had to meet two different and tough requirements. First, it had to let the airplane cruise at high speeds; second, it had to let the airplane land at low speeds.

To do this, Boeing developed a seemingly complex flap system for both the leading and trailing edges of the wing. Fully extended, the 727 wing looks like an all-metal washline, with all kinds of things hanging down. One airline captain is reported to have asked his co-pilot to re-assemble the wing following their takeoff and initial climb.

The high-lift system worked, and continues to work well, giving the Boeing 727 outstanding performance in and out of many airports that could not have handled the larger jets because of runway limitations. The 727 has sold in almost unbelievable numbers to airlines around the world. At mid-1974, more than 1,148 had been sold.

The first model, Boeing 727-100, was planned to carry 70 first-class passengers in four-abreast seating, or 114 tourist-class passengers in six-abreast seats. The second model, the Boeing

727-200, featured a lengthened fuselage and the typical capacity was increased to 160 all-tourist class passengers.

For years, aviation people have talked about a DC-3 replacement. The Boeing 727 is the true DC-3 replacement, opening cities to jet travel just as the great DC-3 opened cities for air travel thirty years earlier.

Manufacturer: Boeing Airplane Company, Seattle, Wash.

Powerplant: Three Pratt & Whitney JT8D-1 axial-flow turbofan engines, each rated at 14,000 pounds of thrust.

Dimensions: Wing span, 108 ft.; overall length, 133 ft. 2 in. (-100) or 153 ft. 2 in. (-200); wing area, 1,650 square feet.

Normal gross weight: 142,000 pounds (-100) or 169,000 pounds (-200).

Payload: 70 to 114 passengers (-100); 160 passengers (-200).

Typical performance: Maximum speed, 652 mph.; cruising speed, 596 mph.; range, 1,450 miles with 160 passengers (-200).

First flight: February 9, 1963.

Total built: More than 1,000 at mid 1974.

LOCKHEED YF-12A

This black interceptor prototype and its sister ship, the SR-71 strategic reconnaissance aircraft, represent the fastest aircraft in the U. S. inventory. The YF-12A established nine world records in four flights on May 1, 1965; they included the world absolute speed record of 2,070.1 mph., and the world absolute sustained altitude record of 80,257.9 feet. It also established a set of closed-course speed records with varying payloads, over two different distances.

Another product of Lockheed's "Skunk Works", the YF-12A had its origins in the early 1960s. The advanced interceptor design was to be able to cruise steadily at more than three times the speed of sound at altitudes above 80,000 feet. It was to be built around a new kind of turbo-ramjet engine that had never been flown before. And the rest of the airplane — its structures, aerodynamics, systems, instrumentation — was equally complex and unknown. C. L. Johnson, who received the 1963 Collier Trophy for the design, said that "... everything on the aircraft from rivets and fluids, up through the materials and powerplants, had to be invented from scratch."

This remarkable airplane was designed by a force never exceeding 200 engineers at its peak. When the airplane was first announced, it was described as the A-11, which was the Lockheed designation; that was soon changed to the SR-71

and YF-12A military designations.

In its planned interceptor role, the YF-12A would have carried a two-man crew — pilot and fire-control officer — and would have been armed with air-to-air missiles, launched by an advanced electronics system.

The YF-12A has an unusually long range for an interceptor aircraft, and also has aerial refueling for increased duration of flight.

One of the YF-12A aircraft is being flown by NASA at the Flight Research Center, Edwards, Calif., in advanced research on the airframe and powerplant.

Manufacturer: Lockheed Aircraft Co., Burbank, Calif.

Powerplant: Two Pratt & Whitney JT11D-20 bleed-bypass turbojet engines each rated at more than 30,000 pounds of thrust.

Dimensions: Wing span, 60 ft.; overall length, 110 ft.; wing area, 1,800 sq. ft.

Normal gross weight: 140,000 pounds for takeoff

Armament: Eight Hughes AIM-47A "Falcon" missiles.

Typical performance: Maximum cruise speed, Mach 3.0 at altitudes above 80,000 feet; combat radius, 1,200 miles.

First flight: 1963.

Total built: Three YF-12A prototypes.

LOCKHEED YF-12A: It once set nine world records in four flights.

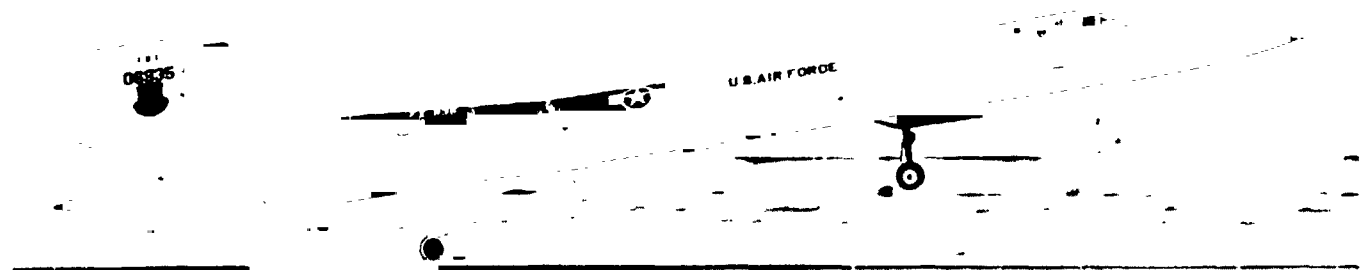

LEAR JET MODEL 23



LEAR JET MODEL 23: These white beauties revolutionized business flying.

This sleekly beautiful aircraft with the looks and lines of a fighter revolutionized business and corporate aviation. It was the first jet aircraft designed specifically for that market, and its initial success has since been matched by continuing sales and development of larger and improved models which are in service around the world.

Very few modern airplanes can be credited to a one-man organization; this one can. William P. Lear conceived the idea and roughed out his concepts on paper before turning over the details to an engineering staff. His strong-headed approach and unyielding attitude got the airplane designed, built, flown and certificated in spite of a move of the complete facilities, including tools, drawings, file cabinets and furniture, from Switzerland to Wichita, Kansas.

The design originated while Lear was living in Switzerland; he established a group within the framework of an existing Swiss aircraft company, and they set to work, detailing the eight-place business craft. For that reason, a lot of the form and substance of the "Lear Jet" was based on a Swiss attack aircraft developed earlier. It had a similar wing, with the sweep on the leading edge and tip tanks for extra fuel that couldn't be housed in the main wing.

The attack craft also lent its rugged structure to the "Lear Jet", and its proven systems saved Lear time and money in the development.

The "Lear Jet" made its first flights at Wichita, and moved into production quickly. Later models followed in development, so that today there is a choice of "Lear Jets" of different sizes and performance.

But they all stem from the first "Lear Jet" 23, a gleaming white beauty of an airplane.

Manufacturer: Gates Learjet Corporation, Wichita, Kansas.

Powerplant: Two General Electric CJ610-1 turbojets, each rated at 2,850 pounds of thrust for takeoff.

Dimensions: Wing span, 35 ft. 7 in.; overall length, 43 ft. 3 in.; wing area, 232 square feet.

Normal gross weight: 12,500 pounds.

Payload: Pilot plus seven passengers, or pilot and co-pilot plus six passengers.

Typical performance: Maximum speed, 570 mph. at 25,000 feet; cruising speed, 526 mph. at 40,000 feet; range, 1,800 miles with three passengers.

First flight: October 7, 1963.

Total built: 104 Model 23; about 450 of all models, at mid-1974.

GENERAL DYNAMICS F-111A

This remarkable series of fighters and fighter-bombers was the first variable-geometry aircraft to go into production, and the first of that type to become an operational military aircraft.

Its major characteristic is its ability to vary the sweepback angle of its wings in flight, spreading them to the fullest for takeoffs, landings, and flight at low speed and high altitudes. For high-speed flight at low altitudes, where the air loads can be very severe, the wings are swept back to reduce the span and therefore the stresses on the wing. This sweepback also reduces the drag for faster flight.

That unusual capability gives the F-111 series the ability to fly at supersonic speeds at sea level, and to exceed two and one-half times the speed of sound at high altitude. But further, the F-111 series is equipped with novel electronic installations which make it able to follow the terrain closely while flying at very high speeds. This system is automatic, and the pilot literally can sit without doing anything while the plane threads its way among mountains and valleys.

The gestation of the F-111 series was long and controversial. But out of it came a unique aircraft, with unique performance. Its fighter version, the F-111A and later models, is in service with

the Tactical Air Command; the fighter-bomber FB-111A flies with the Strategic Air Command. The Royal Australian Air Force operates a number of F-111C aircraft.

The research, development and service experience with the F-111 aircraft has laid a solid foundation for other and later variable-geometry types which now are in development.

Manufacturer: General Dynamics/Convair Aerospace, Fort Worth, Texas.

Powerplant: Two Pratt & Whitney TF30-P-3 or later turbofan engines, each rated from 18,500 to 25,100 pounds of thrust, depending on the model.

Dimensions: Wing span, spread, 63 ft.; wing span, fully swept, 31 ft.; overall length, 73 ft. 6 in. (F-111A).

Normal gross weight: 90,000 pounds (F-111A).

Armament: Missiles; one M-61 Vulcan 20-mm. cannon.

Typical performance: Supersonic at sea level, Mach 2.5 at altitude.

First flight: December 21, 1964 (F-111A); first production deliveries, October 16, 1967.

Total built: 550, including 159 F-111A, seven F-111B, 24 F-111C, 96 F-111D, 94 F-111E, 94 F-111F, and 76 FB-111A (as of mid-1974).

GENERAL DYNAMICS F-111A: Its wing sweepback can vary for best performance.

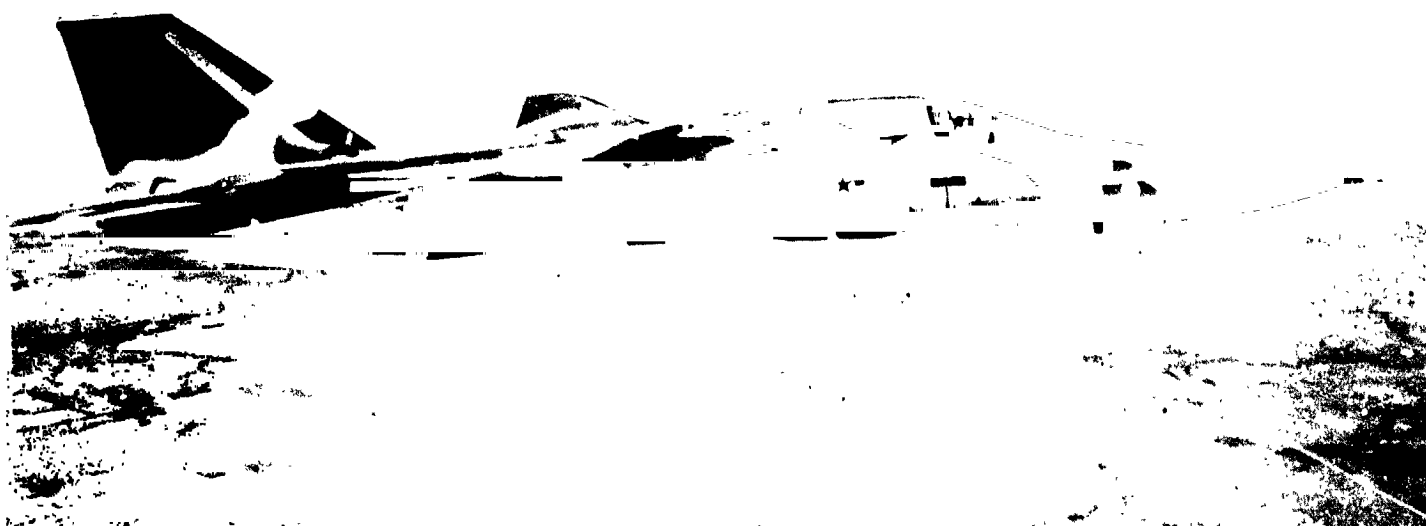

DOUGLAS DC-9

This time, Douglas was first off the mark, and developed this short- to medium-range twin-jet transport to serve the needs of airlines around the world. By May 1974, Douglas had delivered 726 aircraft, more than twice as many as its nearest competitor, and held orders for more than 776.

The DC-9 was designed with economy and growth in mind, and the four current models underscore that philosophy. Detail engineering began in February 1963, and in April, Douglas announced its decision to produce the airplane. Shortly after, Delta Air Lines ordered 15 and optioned another 15, in the initial order of the long DC-9 run. By the time the first two DC-9s were rolled out of the Long Beach factory January 12, 1965, Douglas was holding orders for 58 aircraft with 44 optioned.

The models that started the line were known as Series 10. They were designed to hold 90 passengers, and had an overall length of 104 ft. 5 in. The Series 20, which was not chronologically next, kept the same fuselage, but increased the wingspan for improved short-field performance. The Series 30 stretched the fuselage length to 119 ft. 4 in. overall, and the passenger capacity was raised to 115. The Series 40 has an overall length of 125 ft. 7 in., and a capacity of 125 passengers. Latest is the Series 50, with a further stretch to a 132-foot fuselage and a capacity of 139 passengers.

Douglas pioneered shared-risk production on this airplane. The total financial burden of developing any modern aircraft is so high that ways must be found to ease the cost to any one firm. Douglas found it in a cooperative program, where — for example — de Havilland of Canada assumed the financial risk and built the wing, against the prospect of future production orders for the airplane.

Manufacturer: McDonnell-Douglas Corp., Douglas Aircraft Company, Long Beach, Calif.

Powerplant: Two Pratt & Whitney JT8D-1 or -7, each rated at 14,000 pounds of thrust for takeoff, or JT8D-5, rated at 12,250 pounds of thrust.

Dimensions: Wing span, 89 ft. 5 in. (Series 10), 93 ft. 5 in. (Series 20, 30 and 40); overall length, 104 ft. 5 in. (Series 10 and 20), 119 ft. 4 in. (Series 30), 125 ft. 7 in. (Series 40), and 132 ft. (Series 50), wing area, 925 square feet (Series 10), 1,000 square feet (Series 20, 30 and 40).

Normal gross weight: 77,000 pounds (Series 10) to 114,000 pounds (Series 40).

Payload: 90 to 139 passengers.

Typical performance: Cruising speed, 560 mph., range, 1,300 to 1,725 miles.

First flight: February 25, 1965.

Total built: 726 at April 30, 1974.

DOUGLAS DC-9: Planned for growth and economy, it is in wide service.



CESSNA MODEL 421

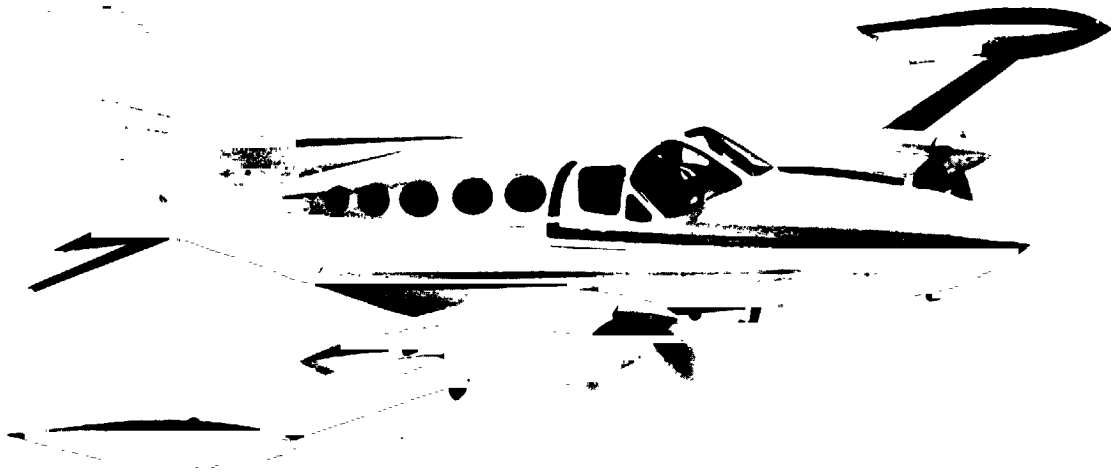

CESSNA 421: It added operational flexibility to business aviation.

This first low-priced pressurized twin-engine aircraft also is typical of the contemporary high-performance light twins that give new operational flexibility to many businesses and private owners.

The design stems from the fact that airplanes fly faster at high altitudes; how high, depends on the type of engine. To get satisfactory high-speed performance from a modern piston-engine airplane, it should be flown well above 10,000 feet. But that altitude is the legal and comfort limit for pilots not using oxygen, and oxygen systems are bulky and uncomfortable. Pressurizing the aircraft, so that the cabin air remains denser like the air much nearer the ground, has been the answer. But pressurizing is an expensive approach; or was, until Cessna developed this light pressurized twin and sold it at a price that was very nearly the same as unpressurized twins.

The Cessna 421 was designed in the mid-1960s to meet the growing need for an aircraft of this type. It was announced by the company in 1966 and placed on the market the following summer. Its success has been phenomenal, surpassing Cessna's marketing estimates.

The fuselage cross-section is oval, which meets the requirements for an efficient and light pressurized structure, and yet provides ample

space inside for a comfortable, even luxurious, layout. Typically, a Cessna 421 will carry four passengers in facing lounge chairs, in addition to the two crew positions. The interior is like a miniature airliner, and can be equipped with galley, bar, toilet, and other amenities. There is ample baggage space inside the cabin, in the nose and in two lockers in the wing nacelles.

Manufacturer: The Cessna Aircraft Company, Wichita, Kansas.

Powerplant: Two Continental GTS10-520-H turbo-charged piston engines, each rated at 375 horsepower.

Dimensions: Wing span, 41 ft. 10 in.; overall length, 36 ft. 1 in.; wing area, 211.65 square feet.

Normal gross weight: 7,450 pounds (1972 model).

Payload: Six to ten people, plus baggage (includes crew positions for two).

Typical performance: Maximum speed, 282 mph. at 18,000 feet altitude; cruising speed, 270 mph. at 25,000 ft.; best range, standard fuel capacity, about 922 miles.

First flight: October 14, 1965. First production aircraft delivered in summer, 1967.

Total built: More than 825, as of mid-1974.

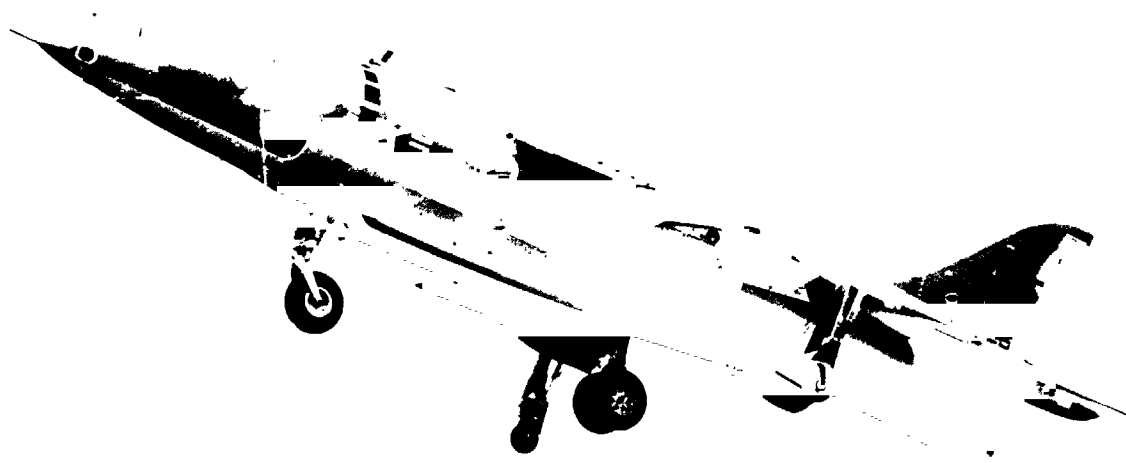

**HAWKER SIDDELEY
"HARRIER":**
The first VTOL
combat craft serves
the RAF and the
USMC.

HAWKER SIDDELEY "HARRIER"

This is the world's first VTOL (Vertical TakeOff and Landing) combat aircraft. Developed from the Hawker Siddeley P.1127 prototype and "Kestrel" production aircraft, the "Harrier" is in service with the Royal Air Force (as the G.R.Mk.1 "Harrier") and with the United States Marine Corps (as the AV-8A).

The key to the design is its unusual powerplant, a highly developed jet engine which has swiveling exhaust nozzles both front and rear. These can be swung to point downward, directing the exhaust vertically, and thus lifting the aircraft straight up on its own thrust. The nozzles then are gradually rotated so that the exhaust jet discharges toward the rear and, as they move, the aircraft makes the transition from vertical flight into the horizontal regime.

The "Harrier" stemmed from the P.1127 prototype and "Kestrel" series, but is somewhat larger and has a more-powerful engine. It is equipped to carry external weapons and other stores, including auxiliary fuel tanks for extended range. The normal range of underwing weapons used by the NATO countries can be carried, mounted on five pylon mounts, two on each wing and one on the fuselage centerline.

The first USMC "Harrier" was accepted January 6, 1971, and earmarked for delivery to Marine

Attack Squadron 513. By then, it had been in front-line service with the RAF for nearly three years. During that time, four U. S. Marine Corps instructor pilots had been serving with RAF "Harrier" units, gaining experience to pass along.

As Marine Corps Major General H. S. Hill said, "An aircraft which is deployed and based as a helicopter, but which packs the punch of conventional attack aircraft, is going to have a far-reaching effect on military aviation."

Manufacturer: Hawker Siddeley Aviation, Ltd., Kingston-on-Thames, England.

Powerplant: One Rolls-Royce Bristol "Pegasus" Mk.101 vectored-thrust turbofan rated at 19,000 pounds thrust.

Dimensions: Wing span, 25 ft. 3 in.; overall length, 46 ft. 4 in.; wing area, 201 square feet.

Normal gross weight: 22,000 pounds; for hover, 16,000 pounds.

Armament: 5,500 pounds of external stores: missiles, gun pods, rocket launchers, etc.

Typical performance: High subsonic speed, supersonic in a gentle dive; range, about 500 miles.

First flight: August 31, 1966.

BOEING MODEL 737

This versatile jet transport was designed by Boeing as their concept of the smallest airplane needed by the major airlines, and as a useful transport for local-service airlines. It was intended to replace the piston-engined and turboprop transports operated by many airlines over their short-haul routes.

The 737 shares with its contemporary, the Douglas DC-9, the major portion of such routes. Nearly 400 have been sold to airlines all over the world.

It was designed to be as small as possible, and to be able to carry a lot of passengers. This led to the use of the "Boeing standard" fuselage, with interior dimensions like those of the 707 and 727 that preceded it. The wide fuselage, perched on the small wings of the 737, led to its nickname of "Fat Albert."

The high-lift system on the 737, essential for its short-runway performance, draws heavily on the experience gained with the Boeing 727.

Stretching the airplane for greater passenger capacity was accounted for from the start of the design, and before the first aircraft ever flew,

Boeing was offering the 737 in two versions. The shorter of these, the -100, was designed to carry from 76 to 99 passengers. The longer -200 was planned around 88 to 113 passengers. Both versions can carry some cargo, as well as passenger baggage, below the floor in holds.

Manufacturer: Boeing Company, Seattle, Washington.

Powerplant: Two Pratt & Whitney JT8D-1 or later models, axial-flow turbofan engines each rated at 14,000 pounds of thrust for takeoff.

Dimensions: Wing span, 93 ft.; overall length, 90 ft. 7 in (-100), 96 ft 11 in. (-200); wing area, 964 square feet.

Normal gross weight: 94,300 pounds (-200).

Payload: Up to 113 passengers.

Typical performance: At Mach 0.75 and 30,000 feet altitude, the 737-200 carries 113 passengers a distance of 1,050 miles, with reserves.

First flight: April 9, 1967

Total built: More than 350 (at mid-1974).

BOEING 737: It meets the needs of major and local-service airlines.

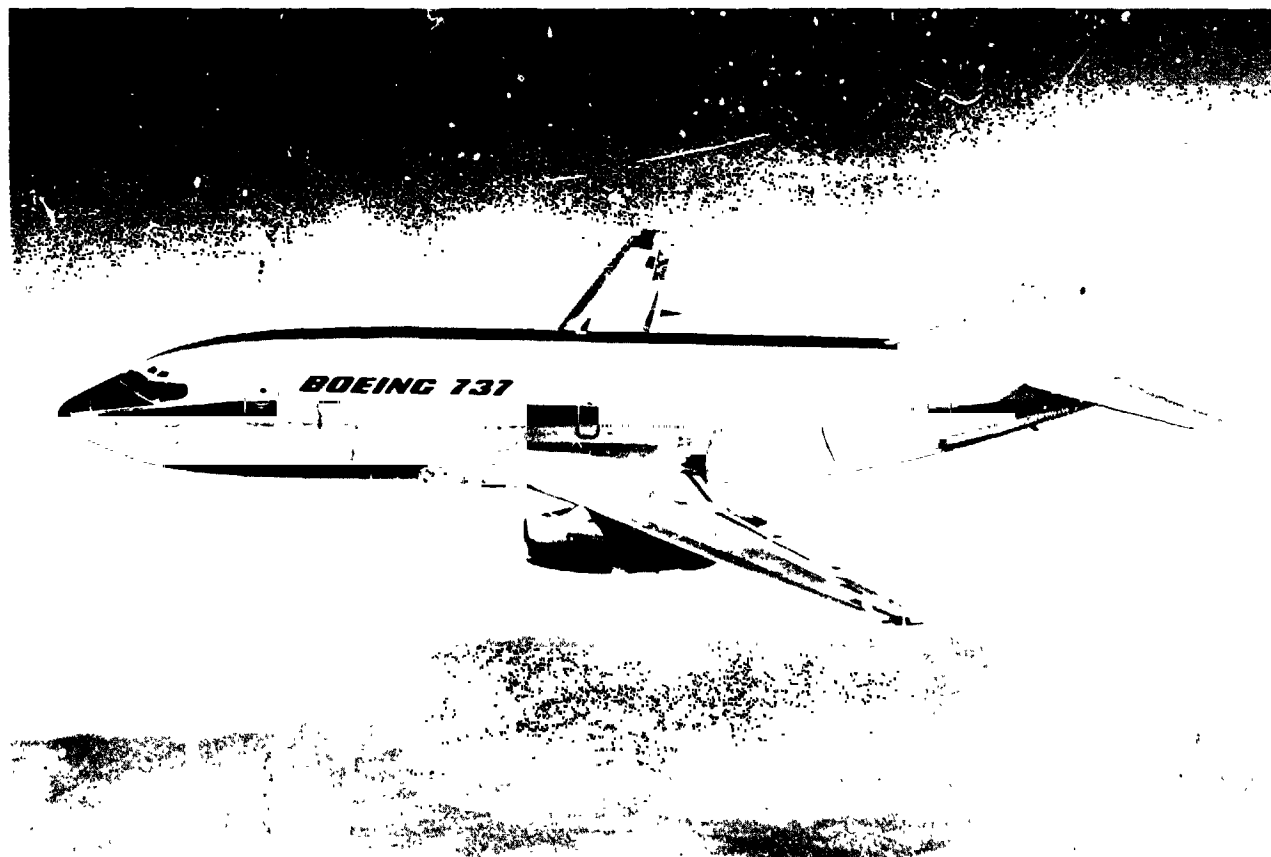

BOEING MODEL 747

The first of the wide-bodied jet transports, the Boeing 747 set the style and pace for a number of later transport designs in the United States and abroad. Its massive size and huge passenger capacity — close to 500 people — initially led to the disliked description of “jumbo jet.” But big and ponderous though it may seem, the Boeing 747 speeds through the air faster, and at higher altitudes, than any of its smaller contemporaries.

The company made a tentative decision to proceed with the design of the 747 in March 1966, and the following month, Pan American World Airways made a dramatic announcement that it would buy 25 of the new transports at a cost exceeding \$525 million.

By December 1966, the first drawings were beginning to go to the Boeing factory floor, and in January 1967 production began in a huge new factory built specifically for the 747.

The orders continued to come in, and in September 1968, the factory doors opened for the ceremonial rollout of the first Boeing 747, on time in a schedule that had been set two years earlier.

Flight testing and deliveries to the airlines followed, and — on January 21, 1970 — Pan Am

made its first commercial trans-Atlantic passenger flight with the new aircraft.

Since then, more than 260 Boeing 747s have been ordered. The first models were supplanted in production by an improved model built in three versions: The 747B, for passengers; the 747C, which can carry either passengers or cargo or both; and the 747F, an all-cargo aircraft.

Manufacturer: The Boeing Company, Seattle, Wash.

Powerplant: Four Pratt & Whitney JT9D-3A or later, axial-flow turbofan engines, each rated at 43,500 pounds of thrust (747A). Other engines and thrust ratings available.

Dimensions: Wing span, 195 ft. 8 in.; overall length, 231 ft. 4 in.; wing area, 5,685 square feet.

Normal gross weight: 710,000 pounds (747A); 775,000 pounds (747B).

Payload: Up to 490 passengers, plus more than 23,000 cubic feet for cargo.

Typical performance: Cruising speed, Mach 0.90; maximum operating range, up to 6,000 miles.

First flight: February 9, 1969. First production deliveries: December 1969.

BOEING 747: First of the big jets, it flies faster and higher than any.

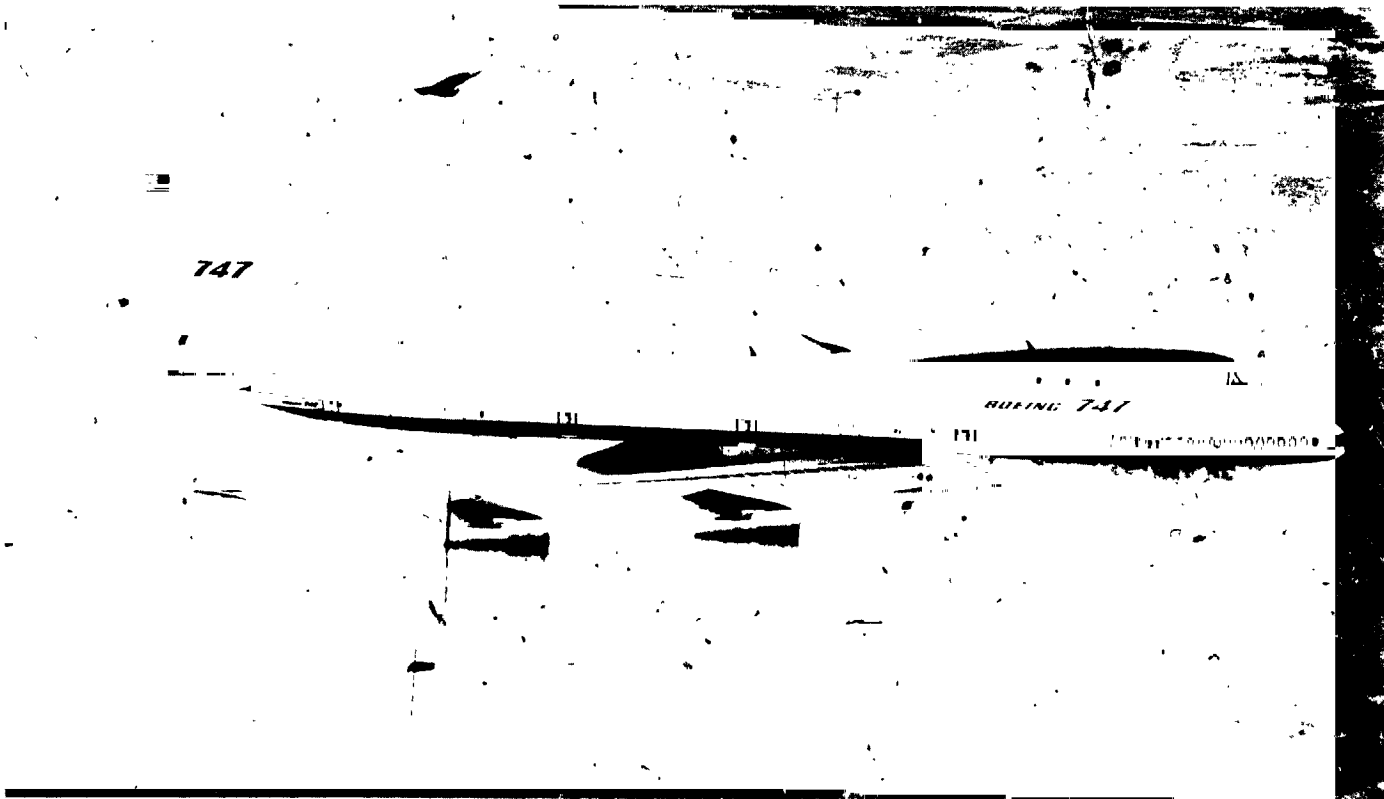

McDONNELL-DOUGLAS DC-10

One way to consider this airplane is as an updated DC-3. Its broad objectives, set in its time context, were the same as those for the first DC-3: Operate economically with a large load of passengers over short and medium stage lengths, using small airports.

Specifically, the DC-10 originated in answer to a requirement credited to American Airlines. American wanted a transport to carry a large load of passengers plus 5,000 pounds of freight from Chicago to Los Angeles. It also had to be able to operate out of New York's La Guardia Airport on hot days with a full payload for Chicago.

Douglas settled on the tri-motor formula and began the engineering design for the tenth of its long line of commercial transports.

The secret of its performance — and of the current generation of wide-bodied jets — is the high bypass ratio turbofan engines, those monstrous assemblages of metal that produce upwards of 40,000 pounds of thrust each. In effect, these jet engines function almost like a very special form of propeller powerplant. They produce their thrust with low fuel consumption and with low noise, endearing the airplane and

engine to the airlines and the community, in that order.

There are three basic models of the DC-10, referred to as the Series 10, 30 and 40 aircraft. They differ in engine installations, dimensions, passenger capacity and range capability, although basically they are all the same DC-10.

Manufacturer: McDonnell-Douglas Corp., Douglas Aircraft Co., Long Beach, Calif.

Powerplant: Three General Electric CF6-6D turbofan engines, each rated at 40,000 pounds of thrust (Series 10).

Dimensions: Wing span, 155 ft. 5 in.; overall length, 181 ft. 6 in. (Series 10)

Normal gross weight: 430,000 pounds (Series 10).

Payload: 250 to 380 passengers.

Typical performance: Maximum speed, 600 mph; range, 4,400 miles (Series 10).

First flight: August 29, 1970 (Series 10).

Total built: 145 delivered as of April 30, 1974.

McDONNELL-DOUGLAS DC-10: Three turbofans are its performance secret.

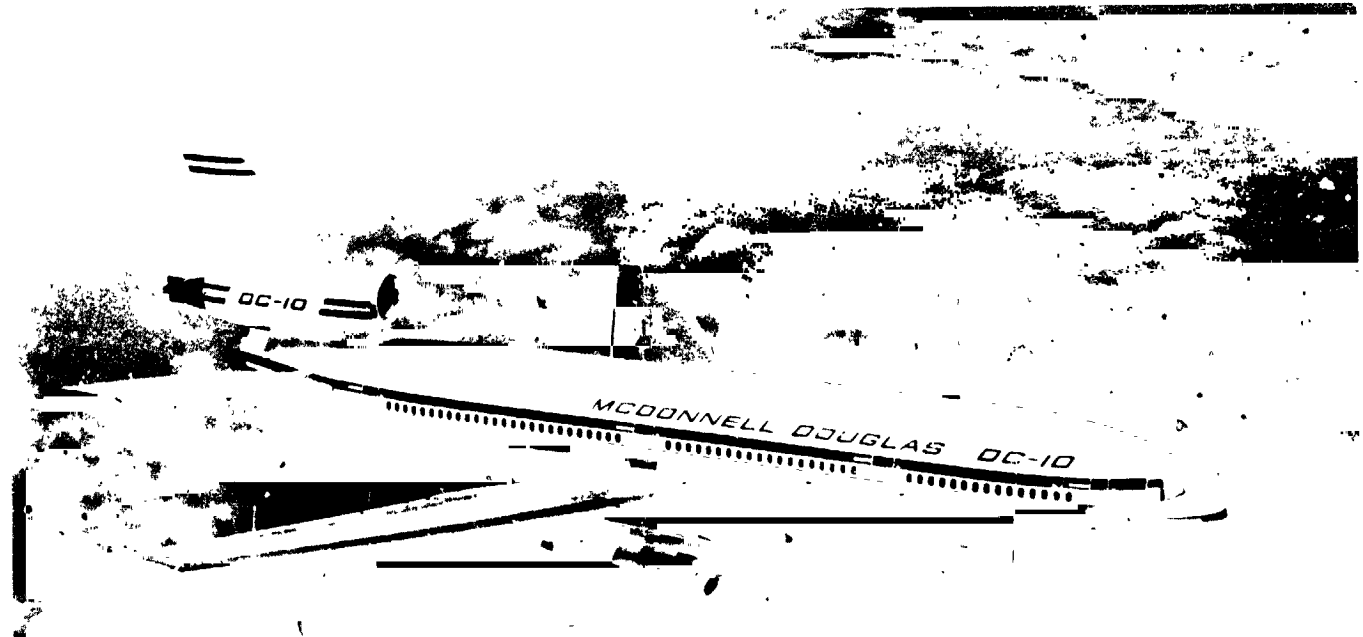

GRUMMAN F-14A "TOMCAT"

Controversial almost from the start and the subject of severe criticism from Congress, the Grumman F-14A is, nevertheless, a significant aircraft. Designed for fighter escort, fleet defense and ground attack duties, the F-14A had to be versatile.

Variable-sweep wings are a major design feature, in an airframe which demands new construction technologies and the use of titanium metal for strength and lightness. Its weapons load is flexible, and can be varied to include air-to-air missiles of three different types as well as its standard 20-mm. cannon.

Pilots who have flown the "Tomcat" talk about its high rate of climb at high altitude, an area of performance where many modern fighters are deficient. Others point out the maneuverability at high altitudes, citing the ability to pull tight turns at high speed.

The variable-sweep wing is flight-programmed, which means that it varies its sweep angle with the performance need. That feature, combined with the high-thrust turbofan engines, provides a rapid response to thrust and a speedy acceleration,

again compared to contemporary Naval fighter types.

But with all this high-speed performance, the "Tomcat" is reported to have a landing speed lower than the current generation of Navy fighters, a plus for carrier operations.

The F-14A was designed to take improved engines and newer weapons or electronic systems as they are developed during the airplane's lifetime.

Manufacturer: Grumman Aerospace Corp., Bethpage, New York.

Powerplant: Two Pratt & Whitney TF30-P-401 turbofan engines, each rated at more than 20,000 pounds of thrust.

Dimensions: Wing span, fully spread, 64 ft. 1 in.; fully swept, 33 ft. 2 in.; overall length 61 ft. 10 in.

Normal gross weight: 53,800 pounds.

Armament: Sparrow, Sidewinder and Phoenix missiles; one M-61 20-mm. cannon.

First flight: December 21, 1970 (prototype).

Total delivered: 76, by mid-1974.

GRUMMAN F-14A: The "Tomcat" excels in high-altitude performance.



McDONNELL-DOUGLAS F-15A "EAGLE"



McDONNELL-DOUGLAS F-15A: Its large wing increases its maneuverability.

This single-seat, twin-engined fighter is the first air superiority fighter to be produced in the U. S. in a quarter of a century.

Designed to be able to outmaneuver anything in the sky, and therefore to have superiority in the air, the F-15A stemmed from the FX competition of 1969. There were three competitors; McDonnell-Douglas won.

Development of the advanced engines that power the "Eagle" had begun long before. These afterburning turbofans develop a thrust equal to about nine times their own weight, a very high ratio for current engines. Engine development was funded jointly by the Air Force and the Navy, although the Navy later gave up its option to buy the advanced Grumman "Tomcat" the engine would have powered.

For all of its large look, the F-15A is only a little bigger than the F-4 "Phantom II", and — in early versions — actually weighs less than the other McDonnell twin-jet.

The relatively large wing area is one secret of the "Eagle" performance. The large surface means that the "Eagle" will be highly maneuverable at high altitudes; there are no current plans to add any high-lift devices to improve that performance.

With the available thrust from the engines exceeding the loaded weight of the "Eagle" by a large margin, the climb performance is spectacular. Takeoff distances are extremely short because of the large amount of available thrust.

The "Eagle" is capable of flying trans-continental distances without refueling, but there is provision for in-flight refueling in the aircraft.

Manufacturer: McDonnell-Douglas Corp., St. Louis, Mo.

Powerplant: Two Pratt & Whitney F100-PW-100, each rated at 20,000 to 30,000 pounds of thrust (exact figure classified).

Dimensions: Wing span, 42 ft. 10 in.; overall length, 63 ft. 10 in.

Normal gross weight: Approx. 40,000 pounds.

Armament: Cannon; air-to-air missiles.

Typical performance: Maximum speed, Mach 2.5 in a dash; range, about 2,000 miles.

First flight: July 27, 1972.

The Langley Research Center is grateful for all these contributions to the display.

The writing and photographic research for this booklet were done by David A. Anderton. Photographs were supplied by manufacturers, and by public and private sources in this country and abroad.

Their cooperation, and the help of many individuals who furnished data or other information, are appreciated.

PHOTO CREDITS

SOURCE	PAGE
Air Force Museum:	18, 33, 58
American Airlines:	24, 26
David A. Anderton:	11, 15
H. Andrews:	48
Beech Aircraft Corp.:	42
The Boeing Co.:	23, 27, 32, 35, 39, 56, 64, 66, 69, 71, 82, 89, 90
Boeing-Vertol:	76
Peter C. Boisseau:	28, 31, 44, 52, 53
The Cessna Aircraft Co.:	87
Curtiss-Wright Corp.:	12, 17, 19, 38, 46
Fairchild Industries:	34
Flight International:	7, 8, 14, 20, 29
Gates Learjet Corp.:	84
General Dynamics:	37, 62, 74, 75, 85
Grumman Aerospace Corp.:	37, 43, 60, 92
Hawker Siddeley Aviation:	88
Lockheed Aircraft Corp.:	25, 47, 59, 68, 83
LTV Aerospace Corp.:	16, 21, 50, 72
McDonnell Douglas Corp.:	40, 45, 55, 61, 77, 78, 86, 91, 93
Musée de l'Air:	5, 6, 9, 10
Piper Aircraft Corp.:	80
Rockwell International:	51, 65, 70, 79
Ryan Aeronautical Library:	22
Sikorsky Aircraft Div.:	54, 67, 81
Textron's Bell Helicopter Co.:	73
United States Air Force:	4, 13, 30, 49, 63
VFW-Fokker GmbH:	41

NATIONAL AERONAUTICS AND SPACE ADMINISTRATION

LANGLEY RESEARCH CENTER • HAMPTON, VIRGINIA

