

NASA TECHNICAL NOTE



NASA TN D-7669

NASA TN D-7669

(NASA-TN-D-7669) A FLIGHT INVESTIGATION
WITH A STOL AIRPLANE FLYING CURVED,
DESCENDING INSTRUMENT APPROACH PATHS
(NASA) 54 p HC \$3.75 CSCL 01C

N74-33452

H1/02 Unclass 50003

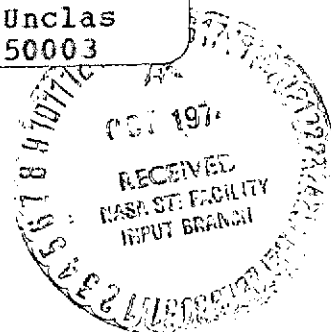

A FLIGHT INVESTIGATION WITH A STOL AIRPLANE FLYING CURVED, DESCENDING INSTRUMENT APPROACH PATHS

*by Margaret S. Benner, Milton D. McLaughlin,
Richard H. Sawyer, Roger Van Gunst, and John J. Ryan*

*Langley Research Center
Hampton, Va. 23665*



1. Report No. NASA TN D-7669		2. Government Accession No.		3. Recipient's Catalog No.	
4. Title and Subtitle A FLIGHT INVESTIGATION WITH A STOL AIRPLANE FLYING CURVED, DESCENDING INSTRUMENT APPROACH PATHS				5. Report Date October 1974	
				6. Performing Organization Code	
7. Author(s) Margaret S. Benner, Milton D. McLaughlin, Richard H. Sawyer, Roger Van Gunst, and John J. Ryan				8. Performing Organization Report No. L-9549	
9. Performing Organization Name and Address NASA Langley Research Center Hampton, Va. 23665				10. Work Unit No. 768-83-04-01	
				11. Contract or Grant No.	
12. Sponsoring Agency Name and Address National Aeronautics and Space Administration Washington, D.C. 20546				13. Type of Report and Period Covered Technical Note	
				14. Sponsoring Agency Code	
15. Supplementary Notes John J. Ryan is associated with Federal Aviation Administration.					
16. Abstract <p>A flight investigation using a De Havilland Twin Otter airplane was conducted to determine the configurations of curved, 6⁰ descending approach paths which would provide minimum airspace usage within the requirements for acceptable commercial STOL airplane operations. Path configurations with turns of 90⁰, 135⁰, and 180⁰ were studied; the approach airspeed was 75 knots. The length of the segment prior to turn, the turn radius, and the length of the final approach segment were varied. The relationship of the acceptable path configurations to the proposed microwave landing system azimuth coverage requirements was examined. The airplane was flown by NASA and FAA research pilots and by a commuter airline captain. The airplane was equipped with a modified flight director that provided guidance throughout the curved, descending approach.</p>					
17. Key Words (Suggested by Author(s)) STOL Curved descending approach Microwave landing system			18. Distribution Statement Unclassified - Unlimited STAR Category 02		
19. Security Classif. (of this report) Unclassified		20. Security Classif. (of this page) Unclassified		21. No. of Pages 52	22. Price* \$3.75

A FLIGHT INVESTIGATION WITH A STOL AIRPLANE FLYING CURVED,
DESCENDING INSTRUMENT APPROACH PATHS

By Margaret S. Benner, Milton D. McLaughlin, Richard H. Sawyer,
Roger Van Gunst, and John J. Ryan¹
Langley Research Center

SUMMARY

A flight investigation using a De Havilland Twin Otter airplane was conducted to determine the configurations of curved, 6° descending approach paths which would provide minimum airspace usage within the requirements for acceptable commercial STOL airplane operations. Path configurations with turns of 90° , 135° , and 180° were studied; the approach airspeed was 75 knots. The length of the segment prior to the turn, the turn radius, and the length of the final approach segment were varied. The relationship of the acceptable path configurations to the proposed microwave landing system azimuth coverage requirements was examined. The airplane was flown by NASA and FAA research pilots and by a commuter airline captain. The airplane was equipped with a modified flight director that provided guidance throughout the curved, descending approach.

The results of the investigation indicated that minimum-size path geometry considered acceptable by the pilots for commercial operations was a combination of 1220 m (4000 ft) straight segment prior to the turn, a 914 m (3000 ft) radius turn, and a 914 m (3000 ft) final approach segment. For the minimum-size path geometry considered acceptable by the pilots for commercial operations, proposed microwave landing system (MLS) azimuth coverages of $\pm 40^\circ$ and $\pm 60^\circ$ would be marginally acceptable for turn radii of 90° and 135° , respectively. For a 180° turn, an MLS azimuth coverage of $\pm 81^\circ$ would be required. Turn radii of at least 1220 m (4000 ft), however, appear preferable for routine commercial operations at 75 knots with this type of airplane to avoid occasional maximum bank angles approaching passenger-comfort limit values and to avoid exceeding passenger-comfort roll-rate limits under crosswind and gusty conditions. For approaches with radii of 1220 m (4000 ft) or less, the passenger-comfort limit of $\pm 0.13g$ in normal acceleration was equaled or exceeded in three-fourths of the approaches. Maximum nose-down pitch attitude angles exceeded an assumed passenger comfort limit of -12° in nearly 60 percent of the approaches. Under crosswind conditions, differences in approach times between approaches from the upwind side (tailwind in the turn) and the downwind

¹John J. Ryan is associated with Federal Aviation Administration.

side (headwind in the turn) of from 27 seconds on the shortest path to 71 seconds on the longest path were experienced. A general aviation type flight director system was modified simply by gain changes in the conventional inputs and the addition of reference bank angle and reference track angle inputs during the turn. These modifications were found to be acceptable for steep descending and curved flight-path steering.

INTRODUCTION

In congested terminal areas where airspace is severely limited, short take-off and landing (STOL) airplanes appear to offer a means of providing increased commercial transport service without significantly interfering with the present conventional operations. Noninterfering STOL arrival paths appear to be possible because of the steep-descent capability and slow-speed maneuverability of these airplanes. In some situations, curved descending flight paths will be required in order to use the nonallocated airspace for separation from obstacles, and for providing noise-abatement routings. Guidance for flight along curved descending approach paths is expected to be available by means of the recommended microwave landing system (MLS) described in reference 1.

The feasibility of several curved, descending instrument approaches on a 6° glide slope for commercial STOL airplanes and the relationship of these paths to proposed MLS azimuth coverage requirements has been studied in a fixed-base simulator for two STOL airplanes. (See ref. 2.) In order to extend these studies to the real-world environment, a flight-test program was conducted at Wallops Flight Center using a De Havilland Twin Otter airplane equipped with a modified flight director system. The objectives of the program were to determine under various wind conditions: (1) the minimum-airspace configurations of curved, descending approach paths (within the constraints of nominal passenger comfort limit) that were acceptable to pilots, (2) the tracking performance capabilities with the flight director system, and (3) the suitability of a modified general aviation flight director for steep, curved descending flight-path guidance.

The airplane crew consisted of an NASA research pilot and an FAA research pilot. A commuter airline captain helped to determine the acceptability of the curved flight paths for commercial use.

The results of the flight-test program are presented in terms of airplane attitudes during the different curved flight paths, the assessment of the modified flight director system, flight-path deviations at entrance to and exit from the turn to the straight final-approach segment, the pilot-acceptable turn radii and straight final segments and their relationships, the MLS azimuth coverage angles required for the acceptable path configurations, and pilot comments.

This investigation was a joint effort of the National Aeronautics and Space Administration (NASA) and the Federal Aviation Administration (FAA). The FAA provided the airplane equipped with the basic flight director system and the services of the project pilot for the FAA STOL tests with this airplane.

SYMBOLS

Values are presented in SI and U.S. Customary Units. Values were obtained in U.S. Customary Units.

d	final approach distance, m
g	acceleration of gravity, m/sec ²
\dot{h}_{\max}	maximum descent rate (occurring for a minimum of 5 sec)
R	radius of final turn, m
V	airplane true airspeed, m/sec
x, y, z	Cartesian coordinates for computer determination of flight-path deviations
θ	pitch angle, deg
ϕ	bank angle, deg
ϕ_{ref}	reference bank angle, deg
$\Delta\psi$	heading error, difference between airplane heading and required course, deg
ψ_{ref}	reference track angle, deg

ABBREVIATIONS

ADI	attitude director indicator
FM	frequency modulated
HSI	horizontal situation indicator
ILS	instrument landing system

IRIG	Inter-Range Instrumentation Group
MLS	microwave landing system
RNAV	area navigation
STOL	short take-off and landing
VHF	very high frequency
VOR	VHF omnirange radio navigation station

TEST EQUIPMENT AND METHOD

The test equipment consisted of the test airplane, basic flight instrumentation plus a modified flight director system, ground-based radar system general purpose computer, telemeter system, and onboard data recording system. A diagram of the overall system is presented in figure 1. The Wallops MPS-19 radar tracked the airplane and sent airplane position coordinates to the Wallops general purpose computer. The computer compared the radar position of the airplane with a preprogrammed approach path and, from this comparison, calculated localizer and glide-slope deviations. These values, with the reference and discrete signals shown in figure 1, were telemetered to the airplane. The localizer and glide-slope deviation data were displayed on the flight director instruments and, with the other telemetered signals, were used in the airplane flight director to provide flight director steering information. The signals were recorded onboard and on the ground in the general purpose computer facility.

Airplane

The test airplane, a De Havilland Twin Otter, is a twin turboprop driven airplane with high lift devices (double slotted flaps), a high wing, fixed landing gear, and STOL capability. It is capable of carrying up to 20 passengers and a crew of 2. Table I lists the airplane characteristics, and a photograph of the airplane is presented in figure 2.

Flight Instrumentation

Views of the pilot's and copilot's instrument panels are presented in figure 3. The flight director system included an attitude director indicator (ADI), a horizontal situation indicator (HSI), a controller and computer, and a runway heading selector. The ADI and the HSI can be seen in the center of the pilot's instrument panel and are shown in greater detail in figure 4. The flight director pitch and roll command bars of the ADI were

scaled so that a ± 1.9 cm (± 0.75 in.) displacement of the pitch command bar was equivalent to $\pm 28^\circ$ pitch angle command, and a ± 0.5 cm (± 0.2 in.) displacement of the roll command bar was equivalent to a 20° bank angle command. Glide-slope deviations were indicated by the vertically moving pointer on the right-hand side of the ADI. The pointer movement was scaled so that the distance between dots represented a deviation of 50 percent of glide-slope path width above or below the glide-slope center line. The localizer deviation indicator of the HSI was scaled so that a ± 0.952 cm (± 0.375 in.) displacement of the bar was equivalent to the localizer half-beam width. Expanded (increased sensitivity) localizer deviations were shown on the ADI. The distance between dots represented a deviation of 20 percent of localizer path width to the right or left of the localizer center line. (The widths of the glide slope and localizer beams, which were functions of the distance from the runway, are described in the section "Test Program.")

The pilot's instrumentation contained some additional features which were not included on standard instrument displays. A blue annunciator light located at the top left of the HSI illuminated 5 seconds before commanded turn initiation and remained on until 5 seconds before commanded turn exit. Another feature provided for improved situation information in the turns was a servo drive on the course pointer in the HSI. The aircraft received continuous information from the ground computer on the required course. The servo then drove the course pointer in such a manner that the required course was always displayed to the pilot. The turn annunciator light and the servo-driven course pointer features were developed in the simulation tests of reference 2. The runway heading selected (fig. 3(b)) was indicated on the HSI by the runway-heading index (fig. 4(b)).

Flight Director System Logic

A short investigation in the flight simulator of reference 2 was used to establish satisfactory gains and constants for the flight director glide slope and localizer mode. The simulation included the actual lags in the input signals as given in the later section "System Lags." The gains and constants used in the flight investigation were made to correspond as close to the simulator established gains as was practical in field modifications to the equipment. Block diagrams describing the glide-slope and localizer modes are given in figure 5.

The glide-slope mode consisted mainly of a glide-slope deviation signal and an incremental airplane pitch change signal. The incremental pitch change signal had a washout time constant of 12 seconds. A reference pitch-down signal of 5° was put in at approximately 228.6 m (750 ft) before glide-slope intercept to pitch the airplane down for the glide-slope transition. A lag circuit with a 0.2 second time constant tended to smooth the glide-slope deviation signal. A glide-slope extension input signal was programmed during the last 152.4 m (500 ft) of altitude to reduce the glide-slope deviation gain to about

one-third of its original value. The glide-slope deviation signal was dimensioned in terms of glide-slope path width.

In the localizer mode, localizer deviation and airplane heading error ($\Delta\psi$) commanded an airplane bank angle. The localizer deviation signal was dimensioned in terms of localizer width and a 0.5 second filter acted to smooth the localizer inputs. The lead network supplied damping which helped to stabilize the localizer mode. Heading error was washed out with a time constant of 7.5 seconds. Course error signal was limited to $\pm 47.5^\circ$ and bank angle signal was limited to $\pm 20^\circ$. The modifications to the localizer mode consisted of two extra signals for the curved portion of the localizer path, a reference bank angle, and a reference track angle. The reference bank angle was expressed as

$$\phi_{\text{ref}} = \text{arc tan } \frac{V^2}{gR}$$

and was the bank angle required to maintain steady turning flight for a given turn radius. In a steady turn, a zero roll-command flight director signal was obtained by biasing the airplane bank angle with the reference bank angle signal.

The reference track angle signal provided a continuous required course along the curved path relative to runway heading. The relationship between reference track angle (ψ_{ref}) and the airplane heading error ($\Delta\psi$) input signal (fig. 5) is shown in the following diagram:

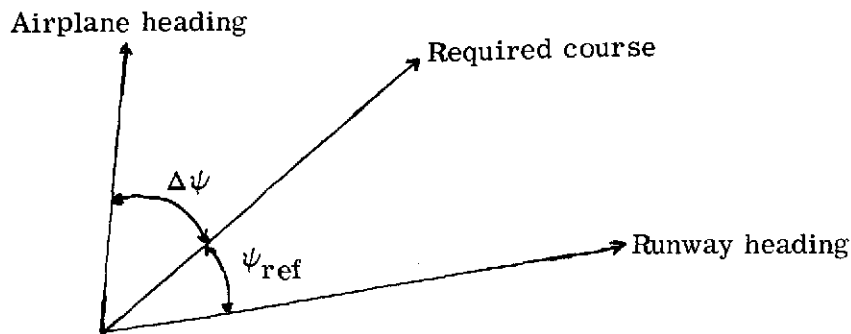

Sketch (a)

Radar

The MPS-19 was a precision tracking radar capable of tracking the airplane through 360° in azimuth and on the final approach down to an altitude of about 61 m (200 ft). The minimum tracking altitude generally depended on the amount of interference signal received from background reflections. An S-band beacon (2700 to 2900 MHz) aboard the airplane provided an enhanced tracking signal for the radar. The MPS-19 tracking radar

was accurate to ± 9.1 m (± 30 ft) in range and ± 1 mil in azimuth and elevation angles. For some of the tests, an FPS-16 precision tracking radar was used. This radar was accurate to ± 4.6 m (± 15 ft) in range and ± 0.1 mil in azimuth and elevation angles. With the FPS-16, the minimum tracking altitude was less than 30.1 m (100 ft). The radar tracking information was converted to airplane x, y, and z positions, with respect to the glide-slope ground intercept point in the general purpose computer.

Computer System

The basic component in the computing system was a Honeywell 625 general purpose digital computer capable of real-time operation. Inputs were from analog to digital converters at a sample rate of 10 times per second. Input data were filtered to reduce noise and smooth the data; the smoothing induced a time lag into the data of approximately 0.5 second. Data output rate of the computer was 10 times per second.

A detailed explanation of the method used to determine the localizer and glide-slope deviation by the Wallops computer is given in the appendix.

Telemetry and Recording Systems

The telemetry system was an IRIG proportional bandwidth FM-FM system. Six channels of information were telemetered to the airplane and are as follows:

Telemetered signals:

- Reference bank angle
- Reference track angle
- Glide-slope deviation
- Left turn discrete
- Right turn discrete
- Time

The localizer deviation was sent to the airplane over a localizer transmitter, a standard instrument-landing-system (ILS) unit.

In the airplane, telemetered data were recorded on a proportional bandwidth FM recording system and the conditions of flight were recorded on a constant bandwidth FM recording system. A total of 25 channels of information were recorded.

System Lags

The many system components – radar, computer, telemetry, flight director – used in processing the data contributed to the lags in the flight director command signals. The approximate lags for each system component are as follows:

Lag source	Lag type	Localizer mode, sec	Glide-slope mode, sec
Computer entry, processing, exit	Transport	0.3	0.3
Computer smoothing circuit	Phase	.5	.5
Aircraft receiver	Phase	.7	.4
Flight director computer	Phase	.5	.2

The total system lags were approximately 0.7 second in the localizer mode and 0.4 second in the glide-slope mode. They were determined by introducing a 10-Hz sinusoidal radar antenna oscillation and by measuring the phase lag of the recorded data. However, the total system lags were believed to be of the same order as the total lags found in conventional flight director usage, because the damping of the localizer and glide-slope deviation signals in the aircraft receiver was reduced to the lowest recommended value; thus, the lags in these signals were reduced and to some degree the lags of the ground equipment were compensated for.

TEST PROGRAM

Figure 6 shows the plan and oblique views of the general shape of the approach paths. These curved paths were formed by connecting straight and circular flight-path segments of various sizes. Final approach distance (the distance from the turn exit to runway threshold) of from 275 m (900 ft) to 455 m (1500 ft) and radii of the turn onto the final approach of from 1829 m (6000 ft) to 610 m (2000 ft) were used. The paths had a final turn of either 0° , 90° , 135° , or 180° with respect to the runway. The MLS azimuth beam was assumed to originate on the center line at the far end of the 610-m (2000-ft) runway (fig. 6(a)) and to have a coverage of either $\pm 40^\circ$ or $\pm 60^\circ$, the two coverages proposed for installations providing curved flight-path capability. (See ref. 1.) The coverage assumed for each path was the smallest of the two values which included, as a minimum, the complete turn to final approach and provided a minimum glide-slope height of 365 m (1200 ft) at the MLS azimuth boundary. The latter requirement was imposed so that the part of the approach prior to glide-slope intercept could be conducted at an altitude no lower than 305 m (1000 ft) with the glide-slope signal thus acquired from far enough below the glide slope to allow time for the capture maneuver. Table II lists the geometry of the paths tested, the assumed MLS azimuth coverage angle, and the height of the glide slope at the MLS azimuth boundary.

Although the azimuth coverages assumed for each path configuration were sufficient to include the turn and the provision for glide-slope intercept at 305 m (1000 ft), or above, coverage was not always sufficient to include a straight segment before the turn long enough to provide the pilot time to stabilize the airplane on the localizer before turn entry. For this reason, some special tests were made in which approach guidance was provided at either 610 m (2000 ft) or 1220 m (4000 ft) before turn entry. Guidance signal information for the path configurations and azimuth coverages given in table II was found to be compatible with the vertical coverage of 0° to 20° recommended in reference 1.

Figure 7 shows the dimensions of the localizer and glide-slope beams; a 6° glide slope was used for all the tests. The localizer and glide-slope beams were curved to fit the flight path being investigated.

The tests were initiated by first setting the runway heading on the selector panel (fig. 3(b)). The aircraft was stabilized at cruise speed (155 knots) at the specified altitude for the path being tested, and the altitude-hold mode on the flight director was manually activated. The altitude selected was such that the glide slope would be intercepted from below. However, an altitude of 305 m (1000 ft) was assumed as the minimum for flight prior to final descent guidance acquisition. The pilot followed radar vectors radioed from the ground to obtain the correct heading to acquire the localizer center line outside the simulated MLS area. With use of radar position information radioed from the ground, the pilot slowed the aircraft to 100 knots for localizer intercept and selected the "Glide-slope arm" and "VOR/Localizer" flight director modes. This procedure simulated an RNAV approach to the MLS coverage area. When the aircraft entered the simulated MLS coverage area, flight director guidance information was sent to the airplane over the telemetry link activating the selected modes. The pilot then used the flight director display information to fly the curved approach path. The pilot wore a visor-type eyeshade which obstructed his outside view to simulate instrument flight conditions. Transition from the glide-slope arm to the glide-slope capture mode was automatic as the airplane entered the glide-slope beam. The pilot slowed the aircraft to 85 knots about 1.8 km (1 n. mi.) before glide-slope intercept by use of 20° of flaps and adjusting power as necessary. He slowed the aircraft to the STOL approach speed of 75 knots at the glide-slope intercept using full flaps (37.5°), and by setting the propeller pitch control for low angle, and adjusting the power as necessary. The copilot took over and executed a missed approach at a decision height of from 61.0 m (200 ft) to 30.5 m (100 ft).

The airplane was operated by a crew consisting of an NASA research pilot and an FAA research pilot alternating as pilot and copilot. Also, a commuter airline pilot flew several paths to evaluate their acceptability for commercial use.

Test Conditions

Figure 8 shows the wind-speed and direction profiles for 7 test days. Wind speeds varied from 4 to 16 knots at ground level and varied greatly with altitude and day of test. The wind data were received from theodolite balloons released every half-hour during the tests. Although up to six sets of balloons were released in 1 day, only a representative data set is presented for each day. However, when each test run was analyzed, the corresponding time period balloon wind data were used. Each day's wind profile has a symbol beneath it. This symbol is used throughout this report to indicate data from that particular test day. Other meteorological data continuously recorded were temperature, barometric pressure, humidity, and ground wind speed and direction.

RESULTS AND DISCUSSION

The results of the STOL curved descending instrument approach path program are presented in figures 9 to 16. Pilots' comments and opinions on the various paths are included in this discussion. Passenger-comfort and piloting flight condition limits used to help rate the acceptability of each path were as follows:

Flight condition	Limit	Basis for limit
Bank angle	30 ⁰	Airline practice
Pitch (floor) angle . .	-12 ⁰	Pilot opinion
Descent rate	365 m/min (1200 ft/min)	Airline practice, unpressurized cabin
Incremental normal acceleration	±0.13g	Reference 3
Roll rate	10 ⁰ /sec	Reference 4

The pitch angle limit is based on pilot opinion of passenger acceptance in lieu of any known published results on the effect of this factor on passenger comfort. The incremental normal acceleration limit is based on values obtained in laboratory experiments at low frequency (0.2 Hz). In these experiments a root-mean-square value of 0.09g was rated objectionable by 50 percent of the subjects. An objectionable rating indicated the subject was adversely affected to the point he would try to avoid flying on that airplane again. Because peak values of acceleration were measured in the present tests, 0.13g was used as the limit value for correspondence with the 0.09g root-mean-square value. The roll rate limit is based on flight experiments in which turn reversals were made. The roll rate of 10⁰/sec was rated as having negligible demands on the passenger and his comfort state; the airplane motion was noticeable, but was not an appreciable factor in comfort or activity.

Typical Results

Typical results of the pertinent quantities recorded are shown in figure 9. The records end at the decision height of 30.5 m (100 ft). Figure 9(a) shows a radar plot of the airplane position relative to the horizontal and vertical flight paths to be flown. The solid lines represent the localizer and glide-slope center lines and beam boundaries. The dotted lines are the consecutive positions of the airplane at 1-second intervals. The assumed MLS azimuth coverage angle of 40° is indicated. The location where the flight path entered the assumed MLS coverage was the point at which telemetry of the guidance data from the ground was initiated. Figure 9(b) shows pertinent flight conditions as a function of time along the flight path. Glide-slope acquisition and the time period in the turn are indicated. For this test, the glide slope was acquired at 130 seconds before reaching an altitude of 30.5 m (100 ft). The turn occurred in the period from 126 seconds to 35 seconds before reaching an altitude of 30.5 m (100 ft). Figure 9(c) shows some of the input and output signals to the flight director computer. The pitch- and roll-command signals were calculated by the onboard flight director computer. (See fig. 5.) The pitch- and roll-command signal variations from zero represent the pilot's failure to satisfy the commands. The scales on these two time histories are deviation signals normalized with respect to the equivalent signal for the half-beam width deviation. The reference track angle signal was calculated by the Wallops ground-based general purpose computer and was continuously sent to the airplane beginning at 152 seconds before an altitude of 30.5 m (100 ft) was reached. This time corresponds to the airplane's entrance into the assumed MLS coverage. Although the reference bank angle signal was sent 14 seconds before the turn initiation, this signal was not switched to the flight director computer until a discrete signal was transmitted from the ground 5 seconds before turn entry.

Flight Director Characteristics

The localizer and glide-slope deviations and flight director commands are presented as a function of time in figure 10 for a noncurved (straight-in) instrument approach. The values are presented as ratios of deviations to half-scale beam widths. Zero time corresponds to an altitude of 30.5 m (100 ft). During the run a deliberate departure from glide slope and localizer was made by the pilot to evaluate the operating characteristics of the flight director. The glide-slope deviation took place from 120 seconds to 95 seconds and the localizer deviation from 40 seconds to 25 seconds.

Initially, the aircraft was on the localizer and descending to acquire the glide slope. The glide slope was acquired at about 135 seconds; from 135 seconds to 68 seconds, except for the intentional offset, the pitch-command and glide-slope deviations were small and constant. The result of the intentional offset was a quick smooth recovery of the glide slope with no overshoots. Below 68 seconds, the glide-slope deviations increased slightly

in size and appeared to become cyclic in nature. This transition to an apparently neutrally stable system had been noted in other flight director tests (ref. 5) and is the result of the effective system gain being too high. This increase in effective gain is caused by the decrease in glide-slope width as the runway is approached. For the present investigation, the effective gain appeared to become too large for a glide-slope half-width of approximately 76.5 m (250 ft), or less. The glide-slope half-width of 76.5 m (250 ft) occurs at a distance from the runway threshold of about 2360 m (7200 ft), which corresponded to an altitude of 236 m (720 ft) for a 6° glide slope. On a standard operational flight director system, a "glide-slope extension" mode automatically desensitizes the glide-slope deviation gain at, or below, a specified "trip" altitude. On standard glide-slope systems, this altitude corresponds to a specified glide-slope half-width as in the present test system. In this manner, the effective system gain is kept low enough to result in a stable system.

Initially, the minimum half-width of the glide slope was limited to 61.0 m (200 ft) in an attempt to keep the effective gain to an acceptable level with the glide-slope-extension trip altitude set at 47.5 m (150 ft). Pilot comments indicated that the system gain was not acceptable below an altitude of 213 m (700 ft). Rather than increase the minimum glide-slope half-width, an attempt was made to desensitize the gain at the lower altitudes by increasing the trip altitude. The trip altitude was adjusted to the maximum value of 152 m (500 ft). The glide-slope deviation gain was changed, beginning at the trip altitude from 1.0 to 0.33, over a period of 15 seconds. The pilots noted and the records show that there was a gain problem at an altitude of approximately 213 m (700 ft), but there was also some improvement below an altitude of 152 m (500 ft).

The intentional offset from the localizer took place at a time of ≈ 40 seconds. The recovery began at about 25 seconds and was smooth and rapid. It is to be noted in figure 10 that, throughout the run, while the roll-command signals were small, the localizer deviations were on the order of ± 0.2 half-beam width. This condition indicated low sensitivity of the localizer mode to localizer deviations. The pilots became aware of the localizer deviations by use of the HSI display and reduced these deviations by supplying a lead correction. This correction effectively increased the localizer system damping but, in turn, increased the pilots' workload in using the localizer mode.

Pilot Comments

Airplane instrumentation.- The pilots felt the flight director system was necessary for flying curved approach paths and, as implemented, provided acceptable guidance. However, the pilots suggested a few improvements. They felt that the localizer command bar was not sensitive enough, because it moved only ± 0.51 cm (± 0.2 in.) full scale. The airplane had to be far off the localizer center line for the indicated correction to be noticeable. Also, the pilots believed the pitch command bar to be too active close to

touchdown (starting at about 1.8 km (1 n. mi.)). The rate of the commanded correction was considered to be too high. Farther out, the commanded corrections were at an acceptable rate for the pilots to keep the pitch attitudes within reasonable values. The pilots determined that a pitch command limiter below 122 m (400 ft) was needed.

During several runs, the pilots made deliberate and significant (up to full half-beam width) deviations from the localizer and glide-slope center lines in the turn to determine the ability of the flight director to give commands to regain the path. Most recoveries commanded by the system were very smooth with no large overshoots. The glide-slope bar commanded small overshoots several times; the localizer bar commands resulted in some small residual localizer error.

The automatically up-dated required course feature of the HSI was of value in allowing the pilot to maintain a general awareness of his position relative to the desired course. The pilots indicated that the lack of range information made the proximity to touchdown difficult to assess. Presentation of the distance-to-touchdown along the flight path as displayed in a digital counter in the tests of reference 2 would have been useful. The pilots felt that although they performed a missed approach at 30.5 m (100 ft) to 61 m (200 ft) for each run, the flight director guidance was good enough to ensure that they could have continued the approach in good visibility to a landing on a typical 610 m (2000 ft) STOL runway for most runs. Glide-slope and localizer deviation errors were used with the flight director by the pilots as a "how goes it" indication to help determine the urgency of the correction commanded by the flight director.

Acceptable flight-path configurations.- The smallest turn radius, 610 m (2000 ft), was considered to be unacceptable because of the high workload and the large bank angles, especially in the turn when a tailwind existed. The 732 m (2400 ft) turn radius was considered to be acceptable unless a tailwind existed in the turn. The airline pilot felt that a 914 m (3000 ft) turn radius was the minimum turn radius acceptable for commercial operations based on the same criteria.

The acceptability of the various final approach distances was influenced by the turn radius used. The 455 m (1500 ft) final approach distance was acceptable only when used with the largest turn radius 1829 m (6000 ft). A final approach distance of 914 m (3000 ft) was acceptable with the minimum acceptable turn radius, 914 m (3000 ft). The airline pilot preferred a final approach distance of 914 m (3000 ft) to provide time to stabilize the final approach with consideration of crosswinds, wind shears, and pilot errors. Also, for the approaches shorter than 914 m (3000 ft), the turn maneuver was considered to be unsafe in instrument flight because of the low altitude.

Special tests were conducted to study the length requirement for a straight segment before the turn to provide the pilot time to stabilize on the localizer before turn entry.

The pilots indicated that the 610 m (2000 ft) distance was too short, but that the 1220 m (4000 ft) distance was sufficient.

The minimum-size path dimensions considered to be acceptable in these flight tests are smaller than those determined in the simulation tests of reference 2. In the simulation tests, a 914 m (3000 ft) final approach condition was considered to be too short to provide time to stabilize the airplane on the flight path, and the turn rollout was at too low an altitude for safety. A turn radius of 914 m (3000 ft) was acceptable only with a 1829 m (6000 ft) final approach distance and winds of 10 knots or less. Also, a straight segment before the turn of 1.8 km (1 n. mi.) was preferred. The reasons for these differences in the acceptable path dimensions between the flight and simulator tests are not understood; however, the larger values for the simulation tests may be the result, in part, of a more conservative attitude of the airline pilots used exclusively in that experiment.

Pilot workload.- The workload of flying the curved, descending approaches with the flight director guidance was considered by the pilots to be essentially the same for turn radii ranging from 732 m (2400 ft) to 1829 m (6000 ft). The workload was rated as essentially equal to that for a straight-in approach with the equivalent guidance. One pilot estimated that the task of flying the curved, descending approaches required 80 percent of his concentration, half, or more, of this concentration being devoted to speed control.

For the curved, descending approaches made with only localizer and glide-slope deviation information for steering guidance, the pilots reported that flight-path control was very difficult and the workload was unacceptably high, although on occasion, the tracking performance appeared to be acceptable. On the curved section of the path, the pilots were unable to determine the correct amount of heading change needed to reacquire the localizer center line from a deviation without an undershoot or overshoot. For some of the smaller radius paths, the pilots were simply unable to fly the pattern. The pilots all agreed that flight director guidance was essential for acceptable workload in flying curved, descending approach paths.

Approach Times

For the different curved flight paths of the tests, figure 11 shows the variations in approach times from turn entrance to arrival at an altitude of 30.5 m (100 ft). Data from straight-in approaches are also shown. The data have been segregated by wind direction on final approach. (See symbols on fig.) For the crosswind approaches, flagged symbols denote approaches with a tailwind component in the turn; unflagged symbols denote approaches with a headwind component in the turn.

As would be expected, the results show that approaches with a headwind on the final approach path took longer than those flown with a tailwind, and those with a headwind

in the turn generally took longer than those with a tailwind in the turn. The spread in approach time for the crosswind conditions experienced increased from 27 seconds for the shortest path to 71 seconds for the longest path.

These results are of particular significance for an air traffic control situation involving the sequencing of traffic by means of curved paths from opposite directions onto a common final approach path. In crosswind conditions, the traffic from one direction will experience a headwind in the turn, the traffic from the other direction, a tailwind in the turn. The difficulty of spacing traffic at 1 minute intervals under such conditions without computer assistance for the controller is evident.

Descent Rates

For each approach, the maximum descent rate \dot{h}_{\max} (occurring for a minimum of 5 sec) is shown plotted against airspeed in figure 12. The data are categorized by wind direction on final approach (symbols). For the crosswind approaches, flags are used on the symbols to denote approaches with a tailwind component in the turn; unflagged symbols denote approaches with a headwind component in the turn.

Comparison of the \dot{h}_{\max} values with calculated descent rates for flight on a 6° glide slope with no wind (dashed line) shows, as expected, generally higher values for the approaches with a tailwind on final path or in the turn and generally lower values for the approaches with a headwind on final path or in the turn. For the wind conditions experienced, the increases in \dot{h}_{\max} from tailwind effects did not exceed approximately 90 m/min (300 ft/min). In a number of cases, the \dot{h}_{\max} values for approaches with a headwind on the final path or in the turn were as large or larger than the \dot{h}_{\max} values in approaches affected by tailwinds. These high values generally resulted during recoveries from flight-path deviations which occurred in gusty conditions. With one exception, a straight approach with a tailwind, the \dot{h}_{\max} values did not exceed 350 m/min (1200 ft/min), the passenger-comfort limit; a similar result was obtained in the simulation tests of reference 2 with tailwinds up to 20 knots.

Airplane Attitudes

Maximum bank angle.- For a number of approaches, the maximum bank angle (held for a minimum of 5 sec) is presented as a function of turn radius in figure 13. The data presented are limited to those approaches in which localizer deviations did not exceed 0.2 of the beam half-width to eliminate approaches in which large lateral offsets were made to assess the capability of the flight director guidance. The data are categorized by wind direction on final approach (symbols) and for crosswind approaches by tailwind in the turn (flags).

The results show a significant increase in the maximum bank angles used compared with the calculated values in turns of less than 1220 m (4000 ft) radius to values approaching the passenger-comfort limit of 30° . These results apparently reflect the difficulty of maintaining flight path for small turn radii especially seen for crosswind approaches with a tailwind component in the turn. Although the maximum bank angles did not exceed the passenger-comfort limit value for these small turn radii, with this type of airplane, turn radii of 1220 m (4000 ft) or greater would appear to be preferable for routine commercial operations at an approach speed of 75 knots.

The results of the simulation tests of reference 2 showed similar increases in the maximum bank angle values with decrease in the turn radius from 1829 m (6000 ft) to 914 m (3000 ft) in both no-wind and crosswind conditions up to 20 knots. Similarly, the values of the maximum bank angle approached the passenger-comfort limit for turn radii of 914 m (3000 ft) and 720 m (2400 ft).

Maximum pitch-down angle.- In 57 approaches, the peak value of the maximum pitch angle (held for at least 5 sec) was found to be -20° . In 59.7 percent of the approaches the maximum pitch angle exceeded -12° (the assumed passenger-comfort limit). The analysis was limited to approaches with headwind or crosswind conditions. These results agree with those of reference 2, in which the peak maximum pitch angle for this airplane in STOL-type approaches was found to be -17.9° ; in 74.3 percent of the approaches the maximum pitch angle exceeded -12° . As discussed in reference 2, STOL-type approaches (with non-powered-lift airplanes) involve pitch-down angles which generally exceed the assumed passenger-comfort limit and investigation of passenger reaction to these high pitch-down angles would appear to be important.

Airplane roll rates.- For a number of approaches, the maximum roll rate measured in the turn is presented as a function of turn radius. (See fig. 14.) The data presented are limited to those approaches in which localizer deviations did not exceed 0.2 of the beam half-width to eliminate approaches in which intentional lateral offsets were made to assess the capability of the flight director guidance. The data are categorized by wind direction on final approach (symbols) and for crosswind approaches by tailwind in the turn (flags).

The results show a general increase in the maximum roll rates used as the turn radius becomes smaller. These results, like those discussed under the section "Maximum bank angle," apparently reflect the difficulty of maintaining a flight path for small turn radii, especially for crosswind approaches with a tailwind component in the turn. For turns of 914 m (3000 ft) radius or less, the maximum roll rates, on occasion, exceeded $10^{\circ}/\text{sec}$, the highest maximum roll rate which was considered to be acceptable for passenger comfort. (See ref. 4.) These results support the maximum bank angle

results which indicated that turn radii of 1220 m (4000 ft), or greater, appear to be required for routine commercial operations.

Airplane normal accelerations.- The probability of equaling or exceeding levels of maximum incremental normal acceleration from the steady-state (1g) condition based on 66 approaches is given in figure 15. The incremental normal accelerations arise mainly from random pitch rate inputs made for flight-path control. The results shown are limited to approaches made with a turn radius of 1220 m (4000 ft), or less.

The results indicate that the passenger-comfort limit of $\pm 0.13g$ in incremental normal acceleration was equaled or exceeded in about three-fourths of these approaches. Statistical comparison of these results with those for approaches made with larger turn radii and final approach distances is not possible because of a limited sample. However, the maximum incremental normal acceleration noted in three-fourths of the approaches with a turn radius of 1829 m (6000 ft) and a final approach distance of 914 m (3000 ft), was less than $\pm 0.1g$. The results for the approaches with the smaller dimensions support the conclusion based on the maximum roll attitude and roll rate results that turn radii of 1220 m (4000 ft), or greater, appear to be required for routine commercial operations unless the airplane is equipped with a ride comfort system.

Turn entrance and exit deviations.- Localizer and glide-slope deviations are presented at turn entries and exits in figures 16(a) and 16(b), respectively. The data are presented for turn radii of 1829 m (6000 ft), 1219 m (4000 ft), 914 m (3000 ft), 732 m (2400 ft), and 610 m (2000 ft). The solid symbols in figure 16(a) denote that the glide slope had not been intercepted at turn entry. For these cases, glide-slope deviations were plotted as zero, as the actual deviation from glide slope is not a measure of how well the pilot is tracking by use of approach guidance. Positive glide-slope deviations denote that the airplane is above the glide slope. Most of the nonzero glide-slope deviation values in figure 16(a) are positive because, in most cases, the pilot did not pitch the aircraft down enough at glide-slope intercept and, therefore, initially ended above the glide path.

From figure 16(a), it can be seen that localizer deviations at turn entry varied from 2.81 beam half-width outside (680 m (2230 ft)) to 3.15 inside (750 m (2450 ft)). These large deviations are associated with several runs flown with deliberate localizer errors introduced at the start of the run to assess the capability of the flight director guidance. The pilots were usually able to correct the localizer deviations quickly; however, some cases of large localizer deviations required large rolling maneuvers (bank angles greater than 30°) in order to make the corrections. Bank angles of this magnitude are unacceptable from a passenger-comfort level.

Localizer and glide-slope deviations at turn exit are presented in figure 16(b). The flagged symbols denote the wind blowing the aircraft toward the outside of the turn at turn exit. The results show that the localizer deviations at turn exit for all turn radii were less than 0.2 inside and 0.4 outside. The localizer deviations were centered about the localizer center line for the 1829 m (6000 ft) turn. As the turn radius was decreased, however, the localizer deviations tended to become mostly outside deviations. For the smaller turn radii, the turn rate required made the localizer command signal more active and hard to follow. Therefore, the pilot tended to get behind and toward the outside at turn exit. From the data of figure 16(b), no definite effects of the wind could be drawn. Glide-slope deviations for all turns were generally less than ± 0.15 and were about equally spaced about the glide-slope center line.

Figure 16 illustrates that for all the turn entrance conditions shown in figure 16(a), including those with deliberate large localizer deviations, the pilots using flight director guidance were able to correct the deviations to the small values shown in figure 16(b). In general, successful approaches to an altitude of 30.5 m (100 ft) were accomplished.

MLS AZIMUTH COVERAGE REQUIREMENTS

On the basis of the minimum-size path geometry considered acceptable by the pilots (see discussion under Pilot Comments - Acceptable flight-path configurations), an analysis of the MLS azimuth coverage requirements was made. The analysis was made by assuming an MLS localizer antenna installation at the far end of the runway as shown in figure 6 and as proposed in reference 1. By using minimum values of turn radius and final approach distances of 914 m (3000 ft) and a straight segment of 1220 m (4000 ft) for localizer acquisition before the turn, the following azimuth coverage requirements were determined from geometrical considerations:

Turn angle, deg	MLS azimuth coverage, deg
90	± 48
135	± 62
180	± 81

These results indicate that the proposed system having an azimuth coverage of $\pm 40^\circ$ might be marginally acceptable for minimum-size STOL airplane approach paths having a 90° turn to final. Similarly, the $\pm 60^\circ$ azimuth coverage system might be marginally acceptable for 135° turns to final. However, to accommodate minimum-size paths with 180° turns to final, an azimuth coverage of $\pm 81^\circ$ would be required. Of course, by

lengthening the final approach distance, the 90° and 135° turn approaches can be readily accommodated with the $\pm 40^\circ$ and $\pm 60^\circ$ azimuth-coverage systems. The final approach distance for the 180° turn approach would have to be lengthened about 732 m (2400 ft) to be accommodated by the $\pm 60^\circ$ azimuth-coverage system. Where land and lack of obstructions permitted, the minimum size paths could be accommodated, of course, by moving the localizer antenna the same distances beyond the far end of the runway.

With the exception of the 180° turn configuration, the MLS azimuth coverage requirements for these tests are somewhat higher than those determined in the simulation tests of reference 2. In reference 2, $\pm 40^\circ$ and $\pm 60^\circ$ angles were found to be adequate for the 90° and 135° turn configurations, and $\pm 80^\circ$ angles were found to be necessary for the 135° turn configuration. The differences in requirements are primarily the result of the smaller size path dimensions found acceptable in these tests compared with the simulation tests. (See discussion under "Acceptable flight-path configurations.")

CONCLUSIONS

A flight investigation using a De Havilland Twin Otter airplane was conducted to determine the configurations of curved, 6° descending approach paths which would provide minimum airspace usage within the requirements for acceptable commercial STOL (short take-off and landing) airplane operations. Path configuration with turns of 90° , 135° , and 180° were studied. The approach airspeed was 75 knots; the length of the segment prior to the turn, the turn radius, and the length of the final approach segment were varied. The relationship of the acceptable path configurations to the proposed microwave landing system azimuth coverage requirements was examined. The airplane was flown by NASA and FAA research pilots and by a commuter airline captain. The airplane was equipped with a modified flight director that provided guidance throughout the curved descending approach.

The results of the investigation indicated that

(1) Minimum-size path geometry considered to be acceptable by the pilots for commercial operations was a combination of a 1220 m (4000 ft) straight segment prior to the turn, a 914 m (3000 ft) radius turn, and a 914 m (3000 ft) final approach segment.

(2) For the minimum-size path geometry considered acceptable by the pilots for commercial operations, proposed microwave landing system (MLS) azimuth coverages of $\pm 40^\circ$ and $\pm 60^\circ$ would be marginally acceptable for turn radii of 90° and 135° , respectively. For a 180° turn, an MLS azimuth coverage of $\pm 81^\circ$ would be required.

(3) Turn radii of at least 1220 m (4000 ft), however, appear to be preferable for routine commercial operations at 75 knots with this type of airplane to avoid occasional

maximum bank angles approaching passenger-comfort limit values and to avoid exceeding passenger-comfort roll-rate limits under crosswind and gusty conditions.

(4) For approaches with radii of 1220 m (4000 ft), or less, and final approach distances of 914 m (3000 ft), or less, the passenger-comfort limit of $\pm 0.13g$ in normal acceleration was equaled or exceeded in three-fourths of the approaches.

(5) Maximum nose-down pitch attitude angles exceeded a passenger-comfort limit of -12° in nearly 60 percent of the approaches.

(6) Under crosswind conditions, differences in approach times between approaches from the upwind side (tailwind in the turn) and the downward side (headwind in the turn) of from 27 seconds on the shortest path to 71 seconds on the longest path were experienced.

(7) A general aviation type flight director system, modified simply by gain changes in the conventional inputs and the addition of reference bank-angle and reference track angle inputs during the turn, was found to be acceptable for steep descending and curved flight-path steering.

Langley Research Center,
National Aeronautics and Space Administration,
Hampton, Va., June 3, 1974.

APPENDIX

COMPUTER DETERMINATION OF FLIGHT-PATH DEVIATIONS

The following scheme was used in the ground-based computer to determine which leg of the approach the aircraft was on. From this knowledge, localizer and glide-slope deviations and other information were calculated. All positions were in reference to a Cartesian coordinate system originating at glide-slope center-line ground-plane intercept and localizer center line. (See sketch (b).)

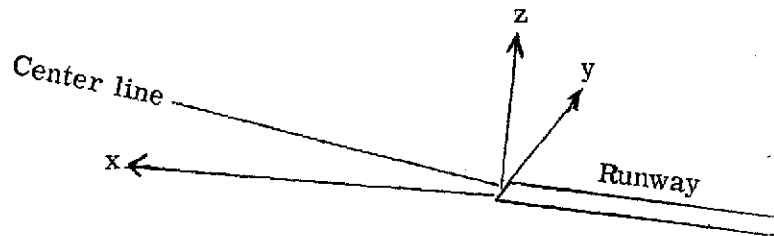

Sketch (b)

The approach path was divided into segments. Each segment was either a straight line or arc of a circle. Restrictions were:

- (1) The flight path must not cross itself.
- (2) No circular segment may exceed 90° .
- (3) Only one glide slope may be used.

Each segment of the ground trace was enclosed by a box whose sides were parallel to the Cartesian coordinate system. As an example, a ground trace of a 180° curved approach (sketch (c)) is shown:

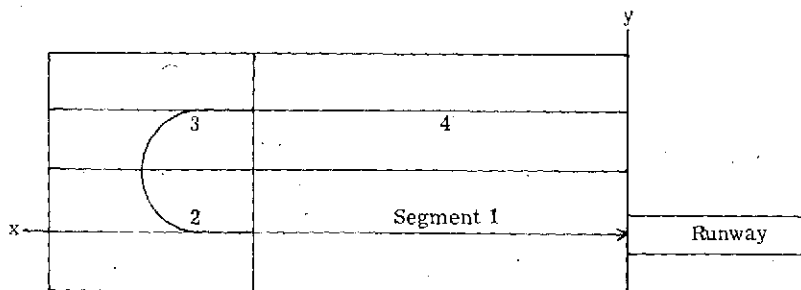

Sketch (c)

If the radar location put the aircraft outside any block of a path, an invalid signal was given. When the radar put the aircraft inside a block, it was necessary to determine which block by surveying the block limits. When the specific block was determined, it was then necessary to determine the aircraft position along and with respect to the desired

APPENDIX A - Concluded

approach path. A perpendicular to the ground-path segment was drawn from the projection of the aircraft on the ground. This perpendicular distance was the localizer deviation. The distance from the interception of the perpendicular with the ground-path segment measured along the path to glide-slope origin (intercept with the ground) was then computed. The glide-slope deviation was taken as the difference between the airplane height and the calculated height of the 6° glide slope at the above computed distance from glide-slope origin. The localizer and glide-slope deviations were expressed in terms of localizer and glide-slope half-widths.

REFERENCES

1. RTCA Special Committee 117: A New Guidance System for Approach and Landing. Vol. 1, Doc. DO-148, Radio Tech. Comm. Aeronaut., Dec. 18, 1970.
2. Benner, Margaret S.; Sawyer, Richard H.; and McLaughlin, Milton D.: A Fixed-Base Simulation Study of Two STOL Aircraft Flying Curved, Descending Instrument Approach Paths. NASA TN D-7298, 1973.
3. Holloway, Richard B.; and Brumaghim, Stanley H.: Tests and Analyses Applicable to Passenger Ride Quality of Large Transport Aircraft. Symposium on Vehicle Ride Quality, NASA TM X-2670, 1972, pp. 91-113.
4. Seckel, Edward; and Miller, George E.: Exploratory Flight Investigation of Ride Quality in Simulated STOL Environment. Symposium on Vehicle Ride Quality, NASA TM X-2620, 1972, pp. 67-89.
5. Grantham, William D.; Nguyen, Luat T.; Patton, James M., Jr.; Deal, Perry L.; Champine, Robert A.; and Carter, C. Robert: Fixed-Base Simulator Study of an Externally Blown Flap STOL Transport Airplane During Approach and Landing. NASA TN D-6898, 1972.

TABLE I.- TWIN OTTER AIRPLANE CHARACTERISTICS

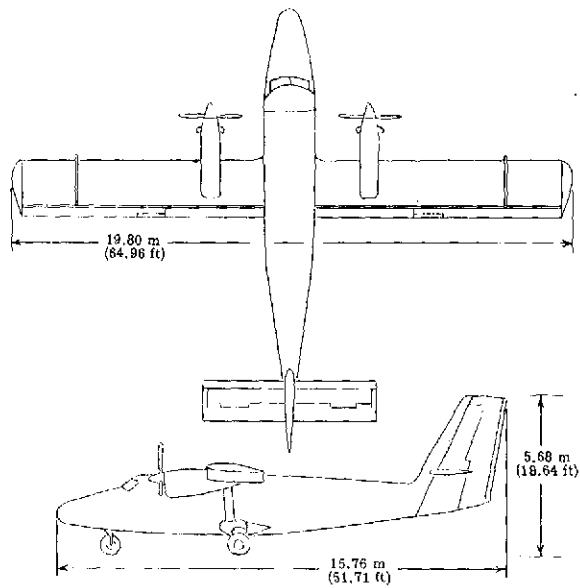

Maximum take-off weight, N	55 603
Wing area, m ²	39.02
Mean aerodynamic chord, m	1.98
High lift devices	Double slotted flaps
STOL landing distance from 15.2 meters, m	320.04

TABLE II.- CURVED APPROACH PATHS

Radius of final turn, R		Final approach distance, d		Turn angle, deg	Turn direction	Assumed MLS azimuth coverage, deg	Glide-slope height at MLS azimuth boundary	
m	ft	m	ft				m	ft
1829	6000	914	3000	180	Left	±60	655	2150
1829	6000	914	3000	180	Right	±60	655	2150
1829	6000	455	1500	135	Left	±60	555	1825
1829	6000	455	1500	135	Right	±60	555	1825
1220	4000	455	1500	90	Left	±60	560	1850
1220	4000	455	1500	90	Right	±60	560	1850
914	3000	2745	9000	180	Left	±40	720	2375
914	3000	2745	9000	180	Right	±40	720	2375
914	3000	914	3000	90	Left	±60	400	1300
914	3000	914	3000	90	Right	±60	400	1300
914	3000	914	3000	180	Left	±60	440	1450
914	3000	914	3000	180	Right	±60	440	1450
914	3000	455	1500	180	Left	±60	350	1150
914	3000	455	1500	180	Right	±60	350	1150
720	2400	2745	9000	135	Right	±60	605	1975
720	2400	1829	6000	90	Left	±40	510	1675
720	2400	1829	6000	90	Right	±40	510	1675
720	2400	1829	6000	180	Left	±40	495	1625
720	2400	1829	6000	180	Right	±40	495	1625
720	2400	914	3000	135	Left	±60	400	1300
720	2400	914	3000	135	Right	±60	400	1300
610	2000	914	3000	135	Left	±60	375	1225
610	2000	914	3000	135	Right	±60	375	1225

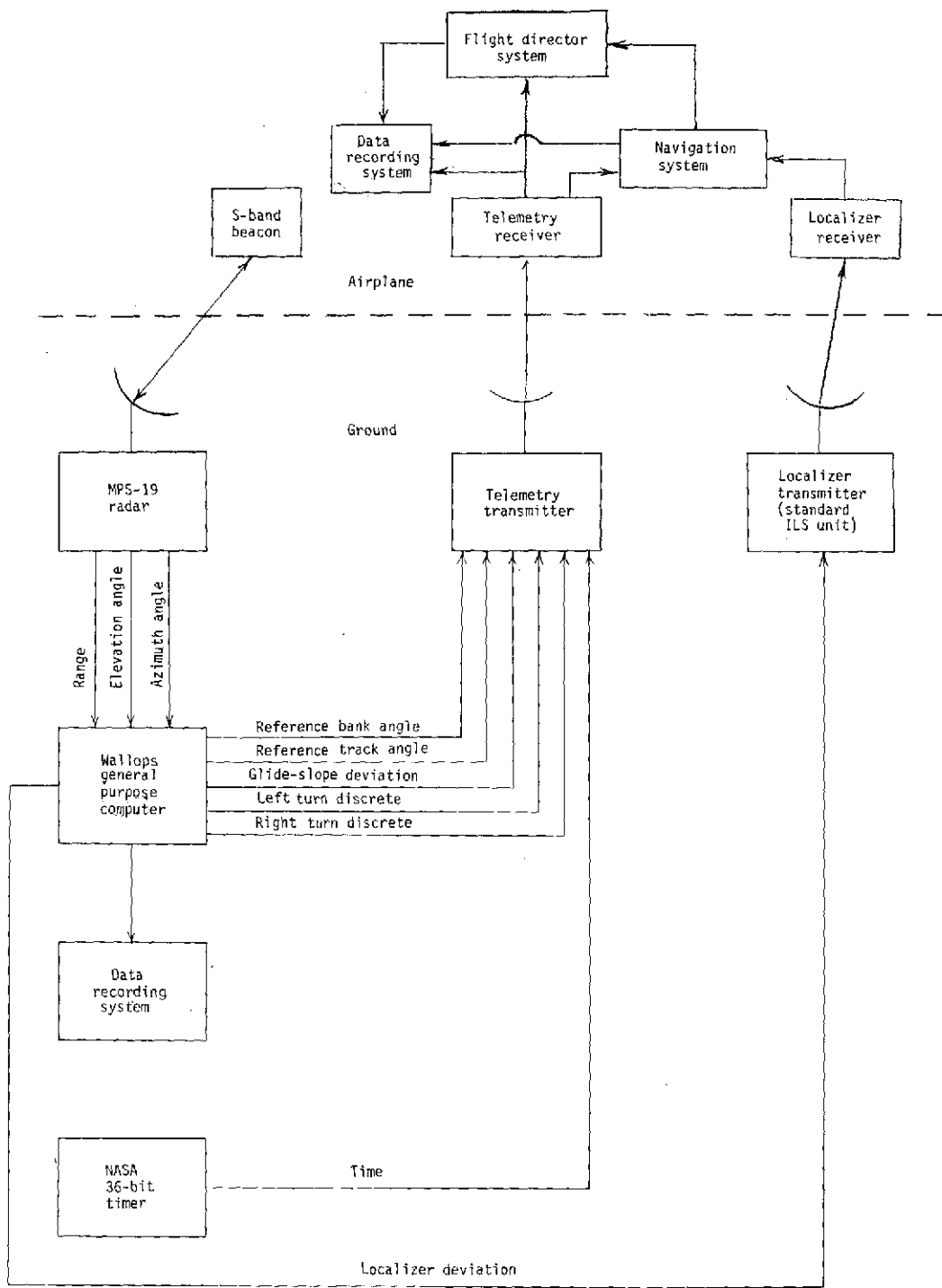
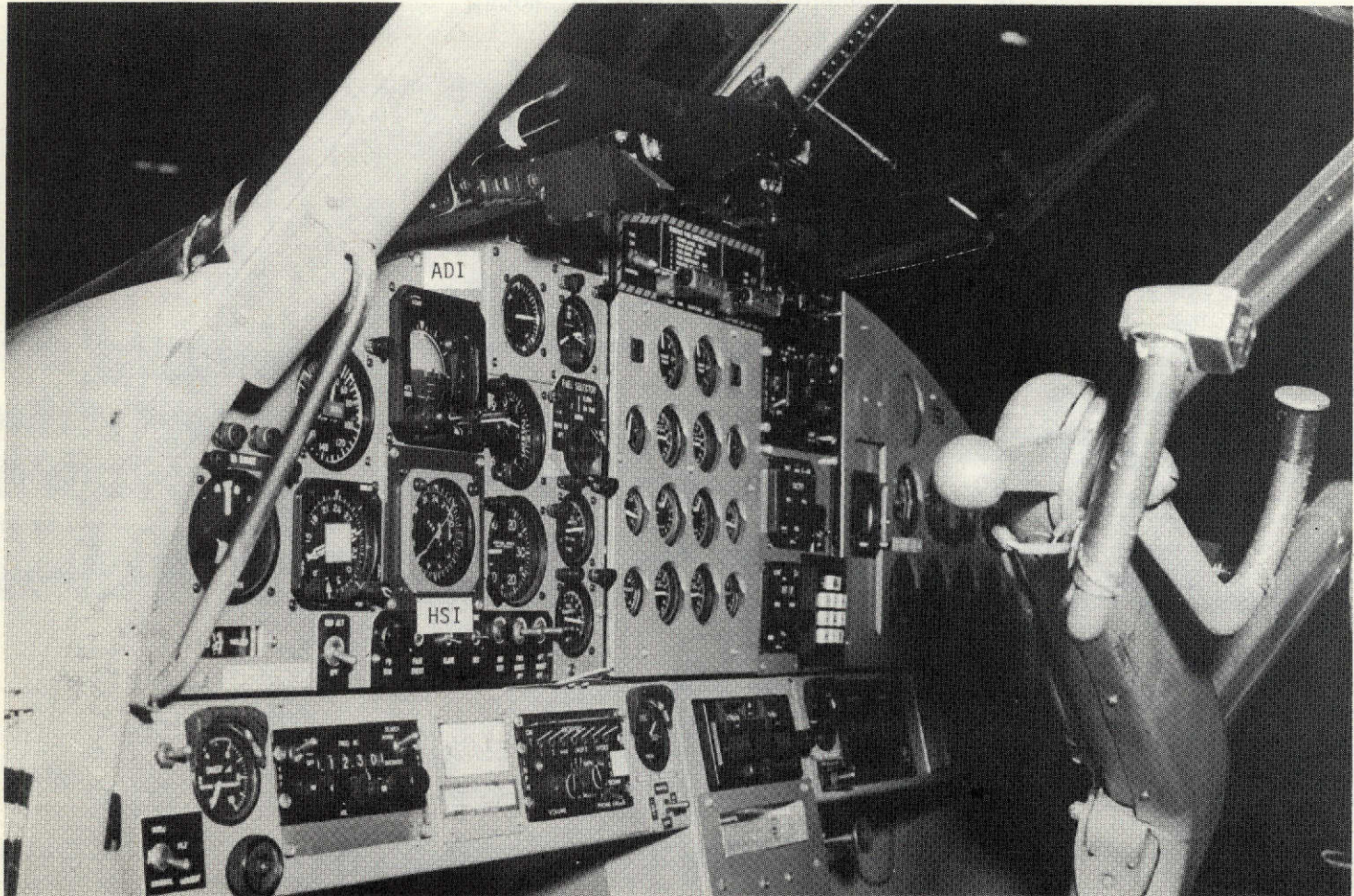

Figure 1.- Guidance information and data recording systems.



L-73-338

Figure 2.- Twin Otter airplane.



L-72-7478.1

(a) Pilot's panel.

Figure 3.- Flight instrument panel.

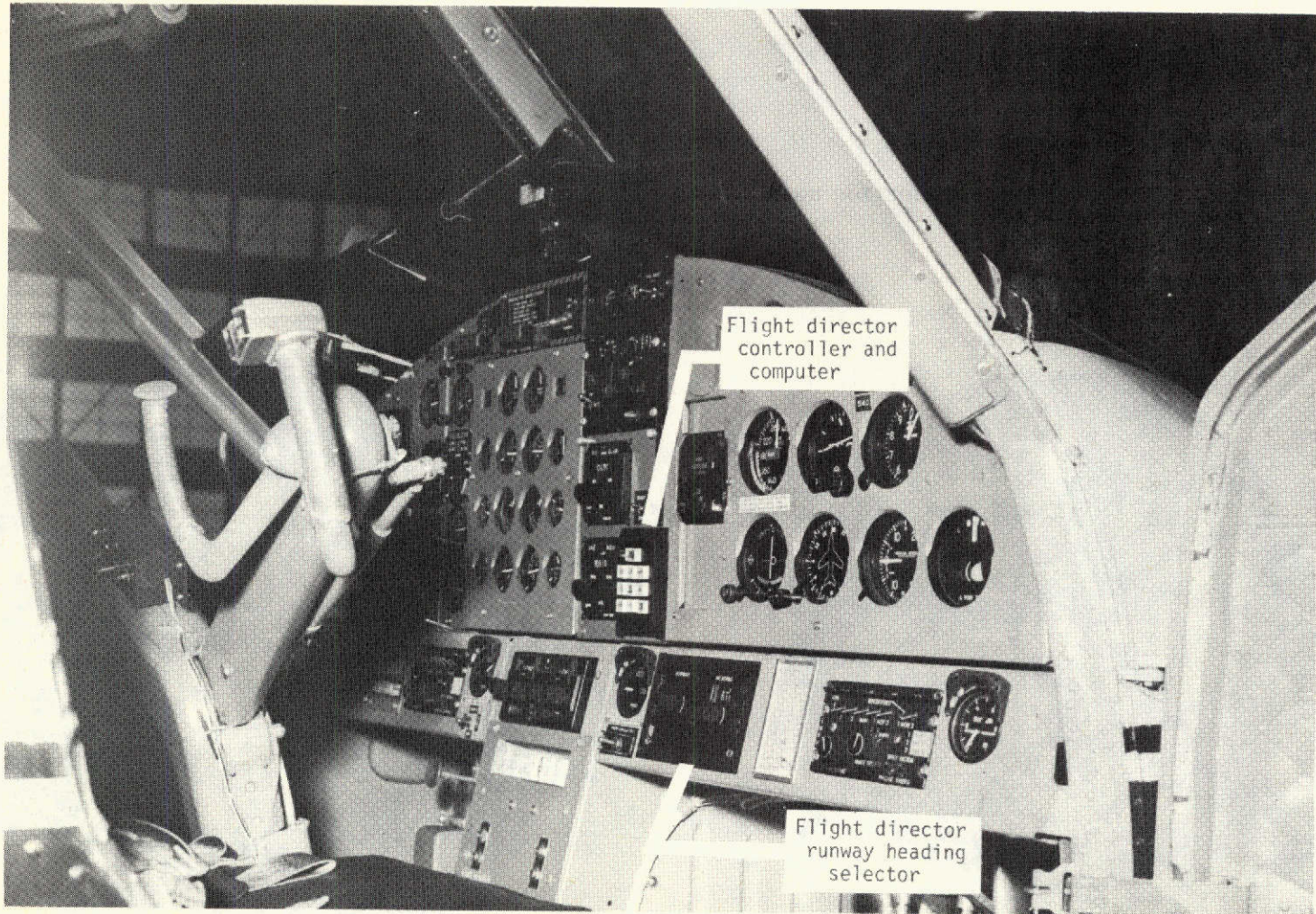

L-72-7468.1

(b) Copilot's panel.

Figure 3.- Concluded.

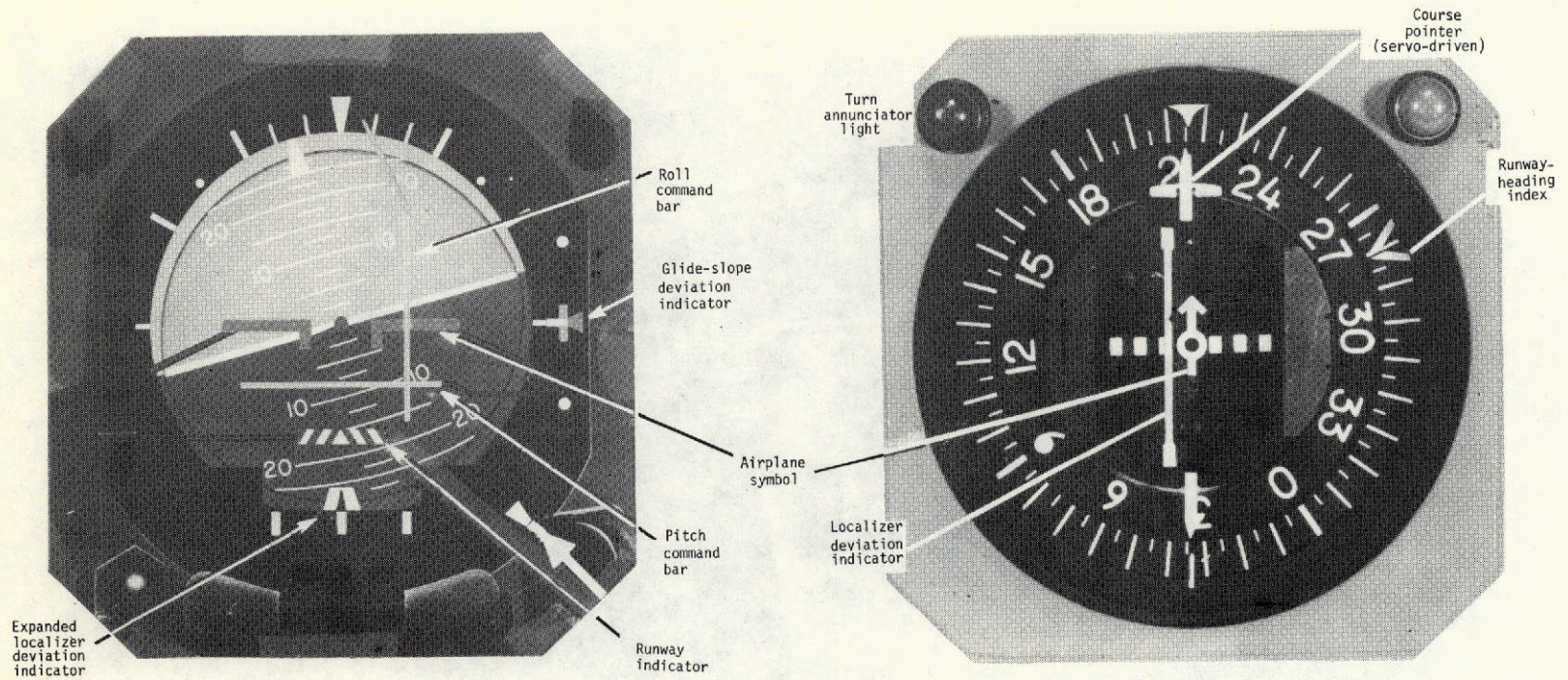

(a) ADI.

(b) HSI.

Figure 4.- Attitude director indicator and servo-driven horizontal situation indicator.

L-74-1118

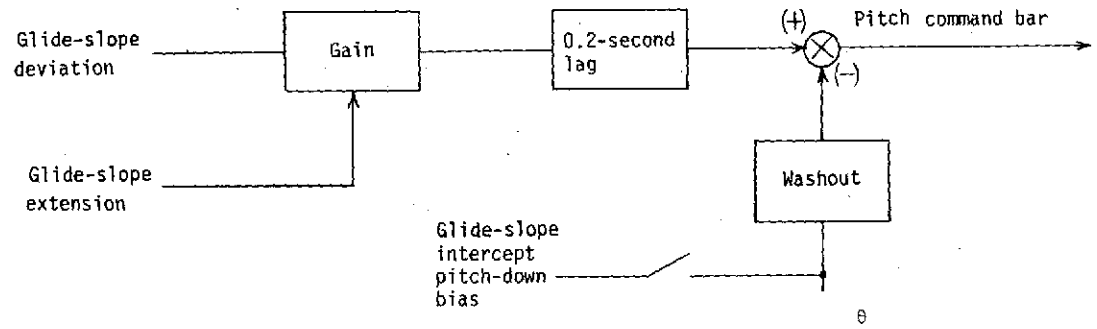

(a) Glide-slope mode.

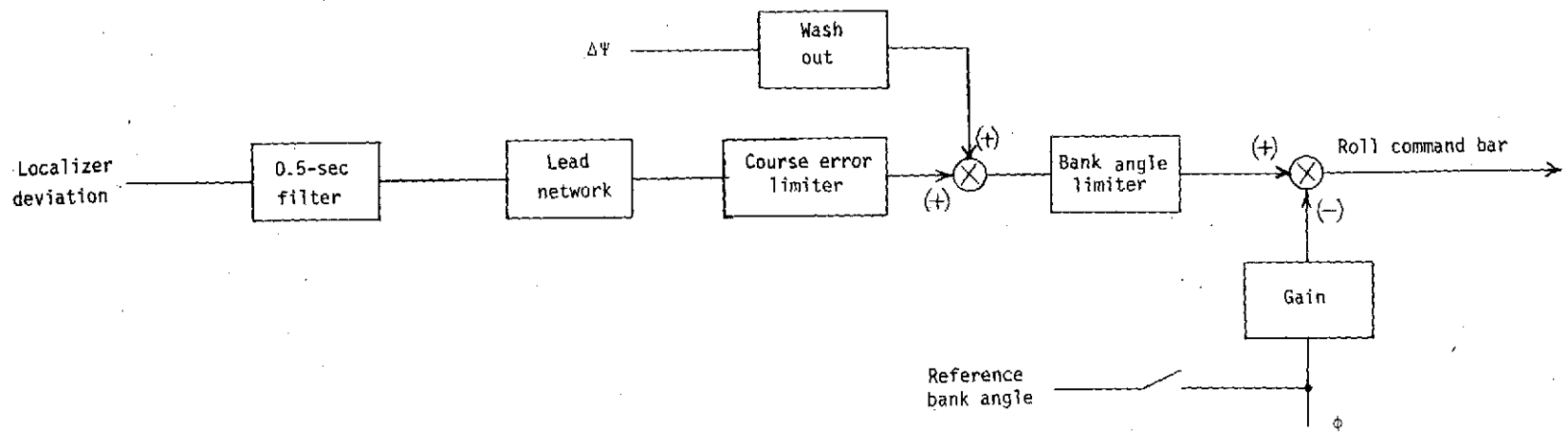

(b) Localizer mode.

Figure 5.- Flight director logic.

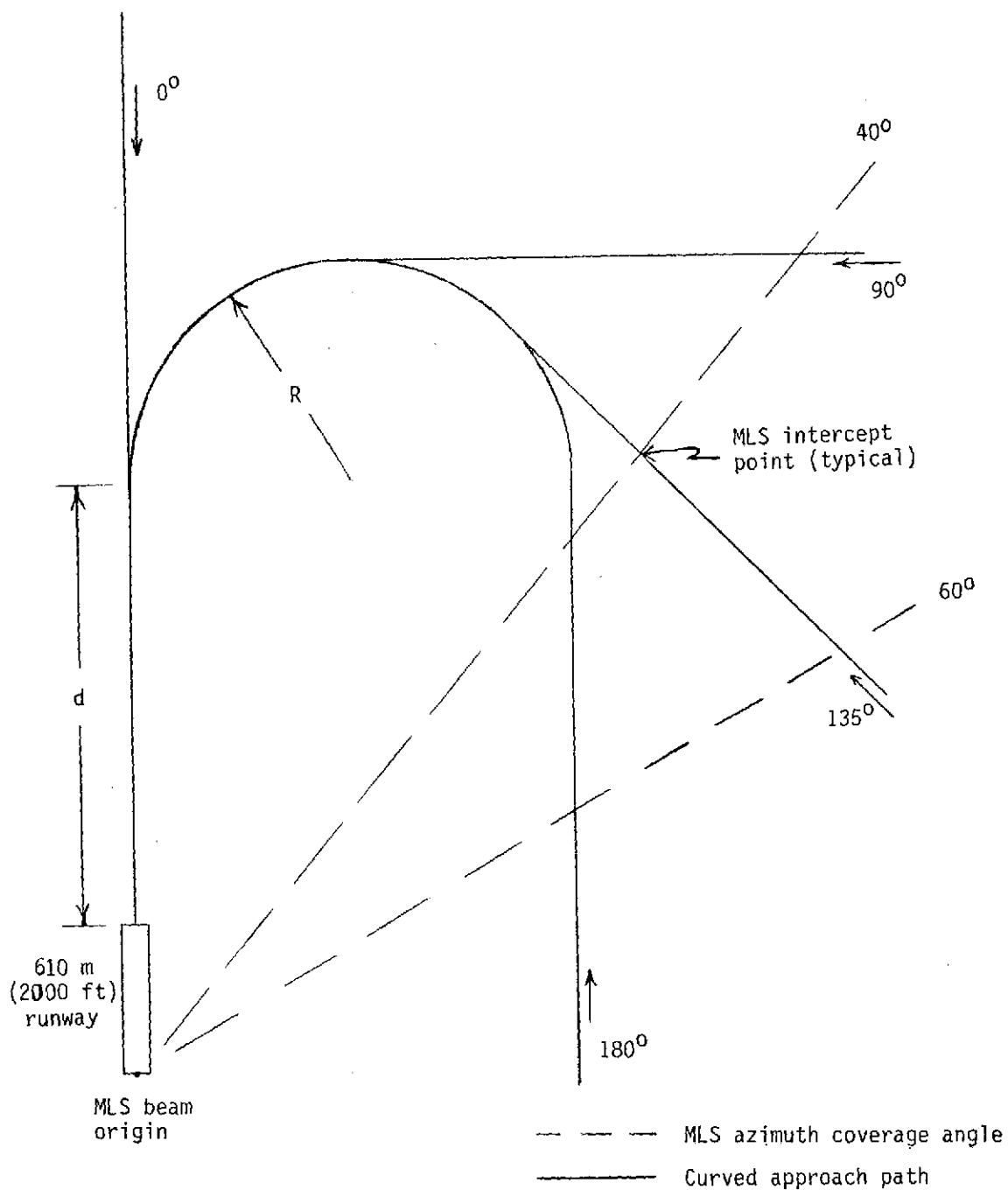

(a) Plan view.

Figure 6.- Curved flight-path shapes and MLS azimuth coverage angles.

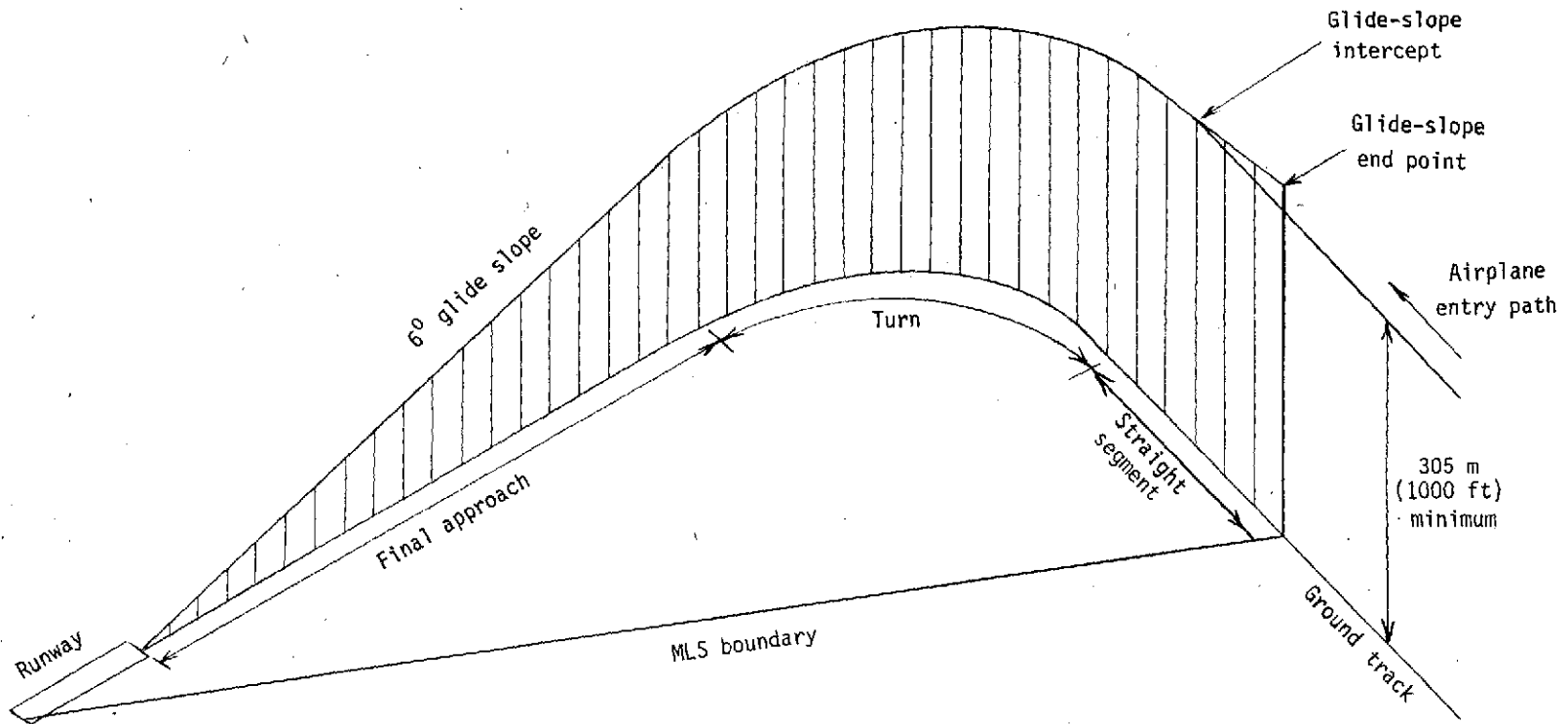

(b) Oblique view.

Figure 6.- Concluded.

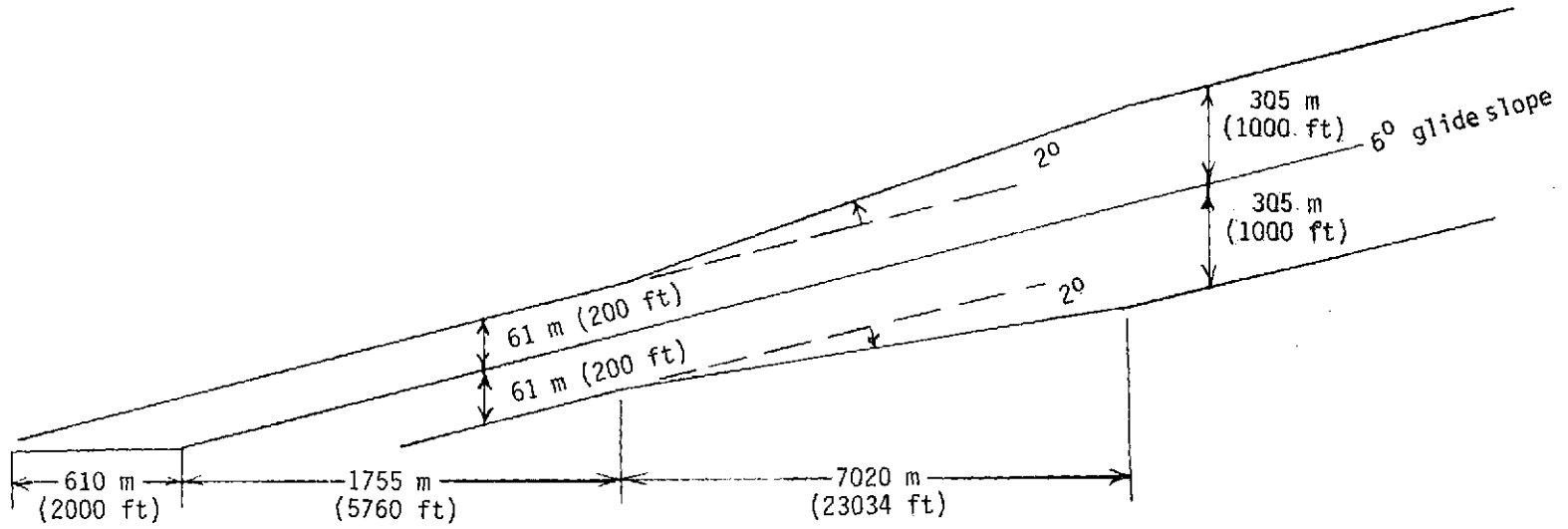

(a) Glide slope.

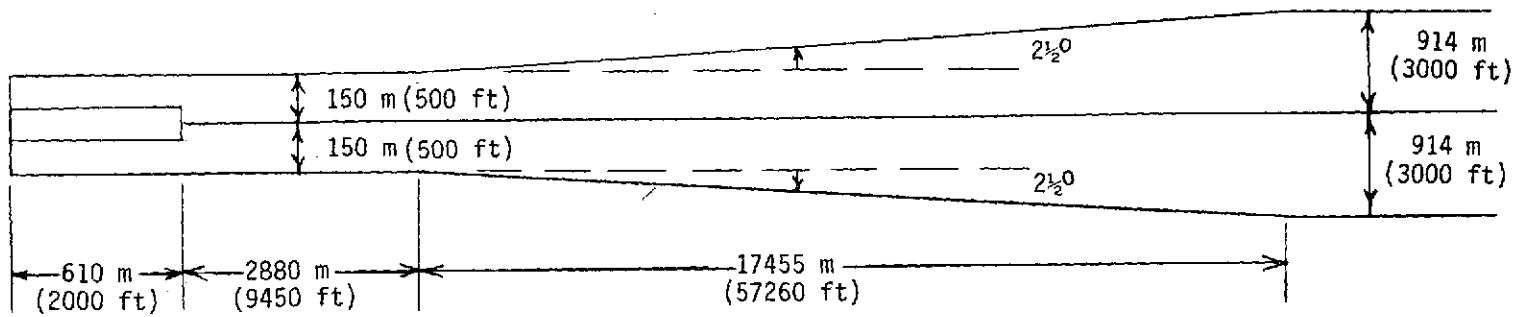

(b) Localizer.

Figure 7.- Glide-slope and localizer beams.

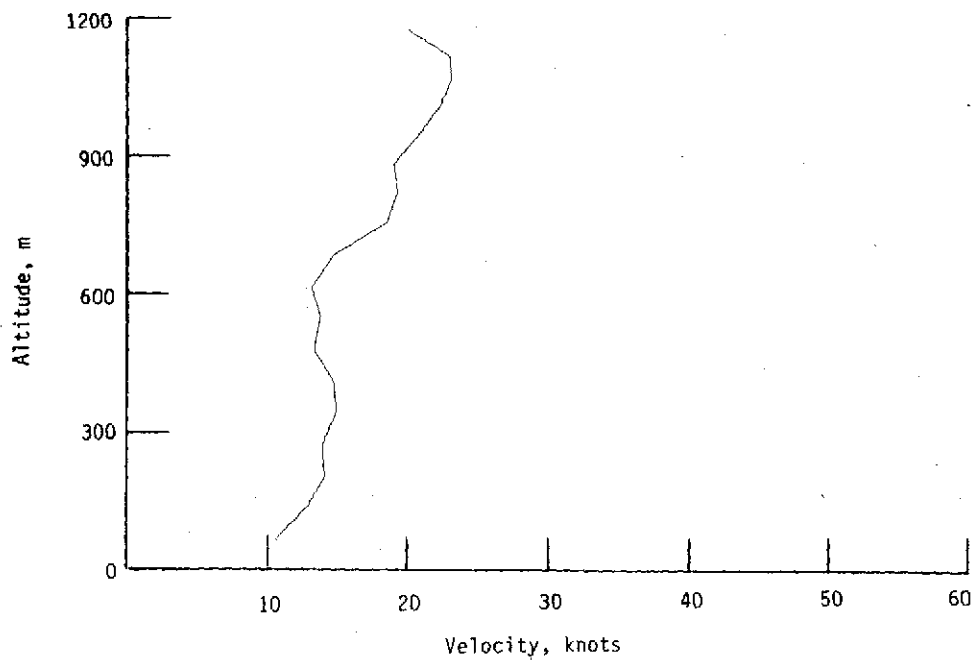
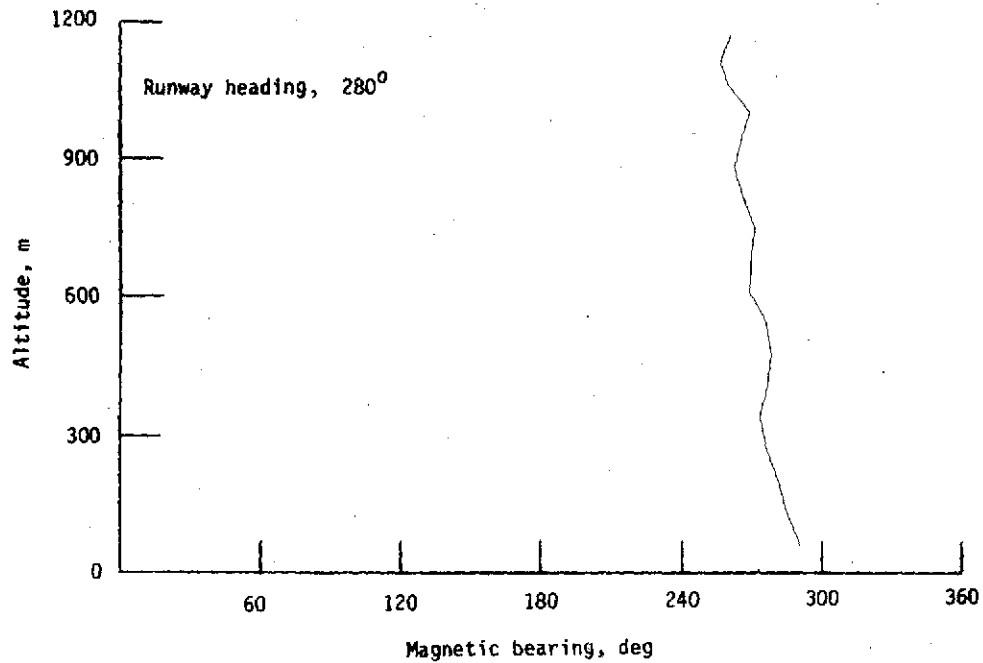

(a) Day 1. Data symbol \odot .

Figure 8.- Wind data.

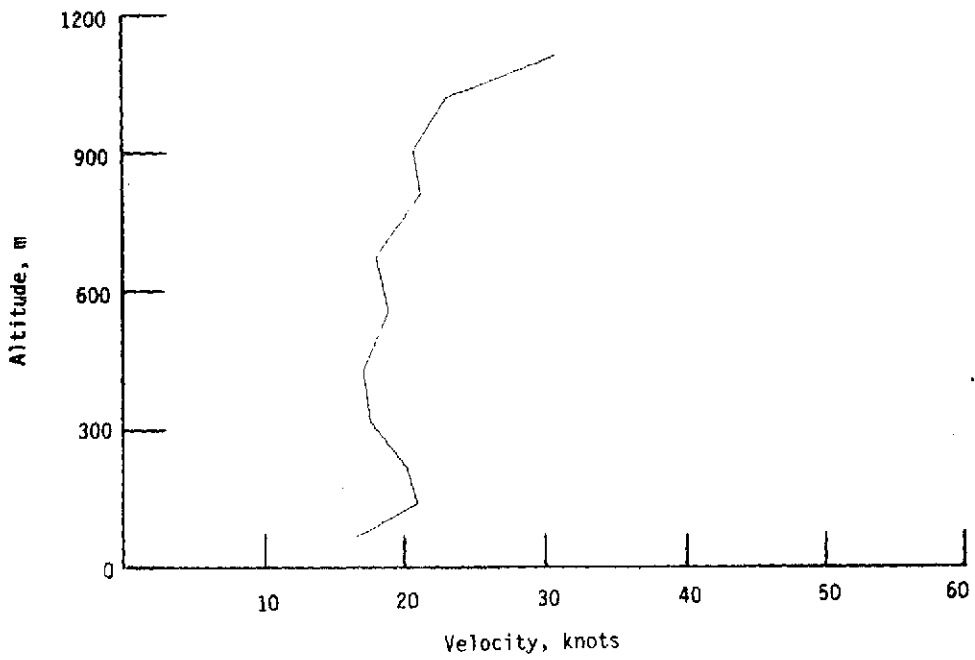
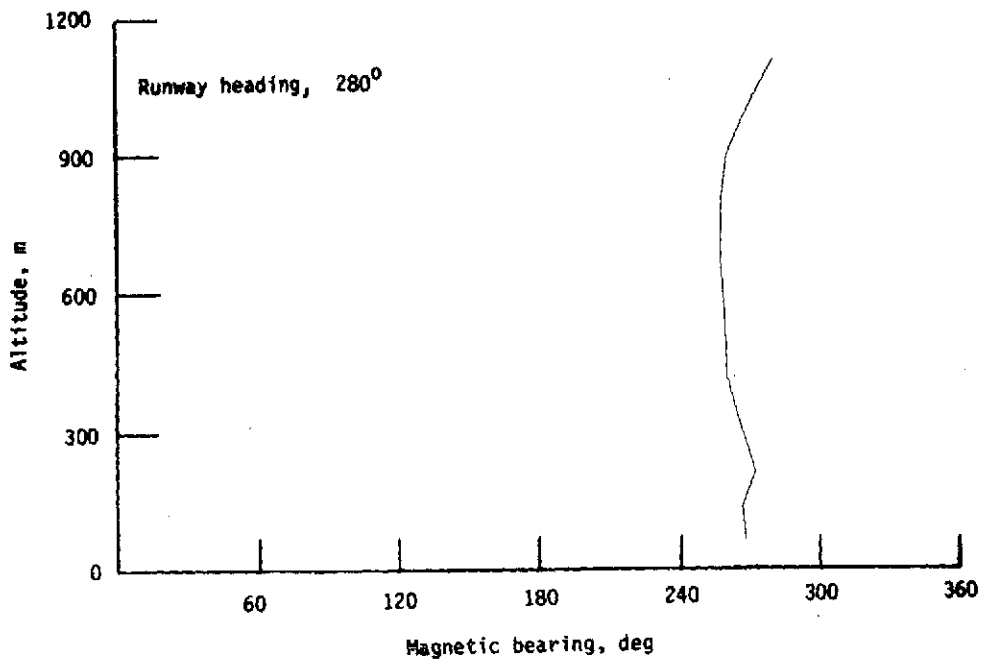

(b) Day 2. Data symbol □.

Figure 8.- Continued.

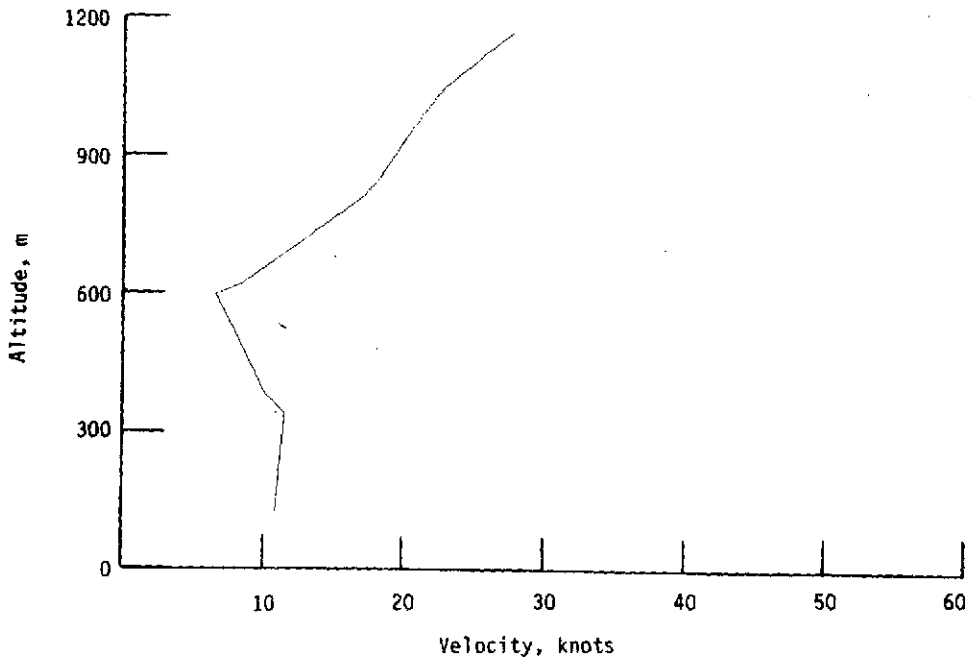
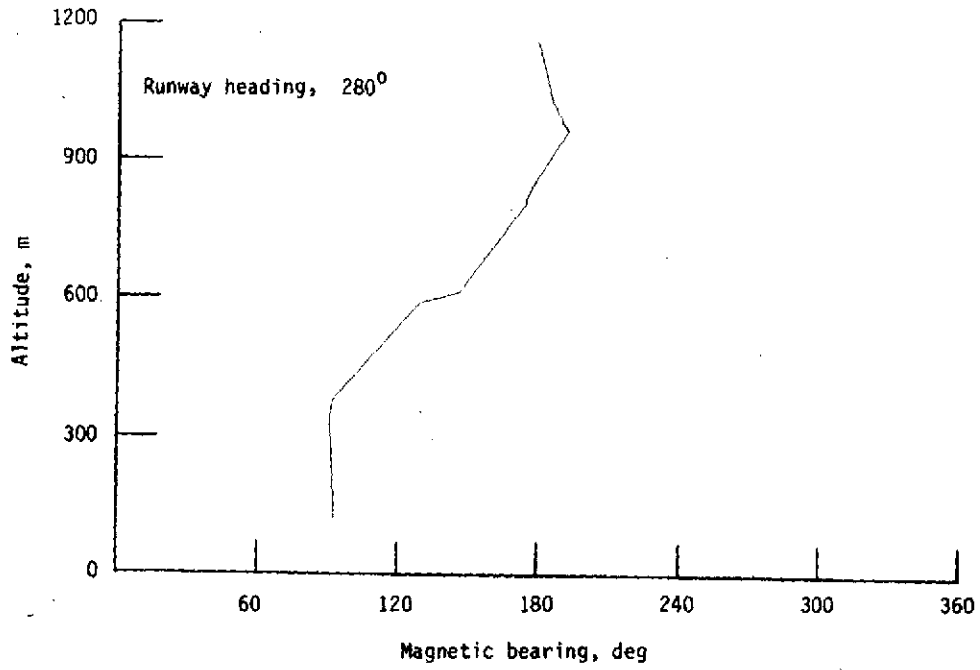

(c) Day 3. Data symbol \diamond .

Figure 8.- Continued.

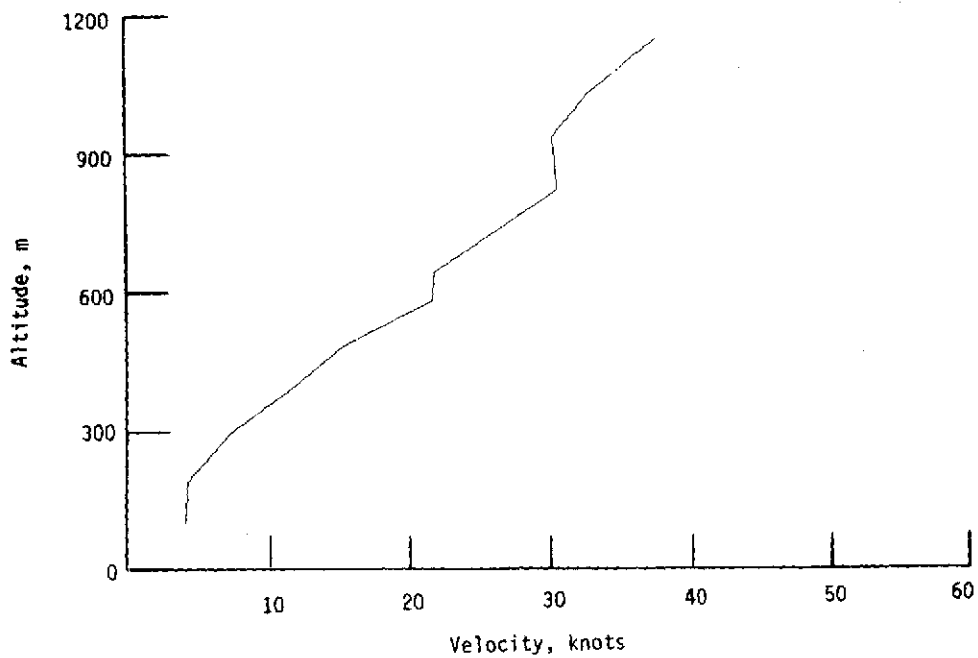
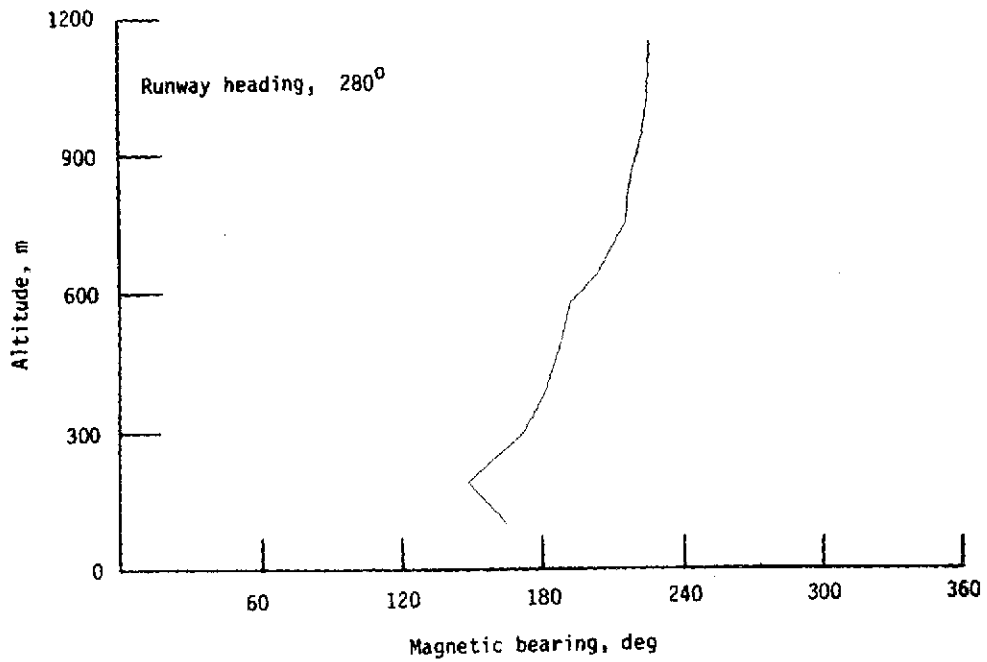

(d) Day 4. Data symbol Δ .

Figure 8.- Continued.

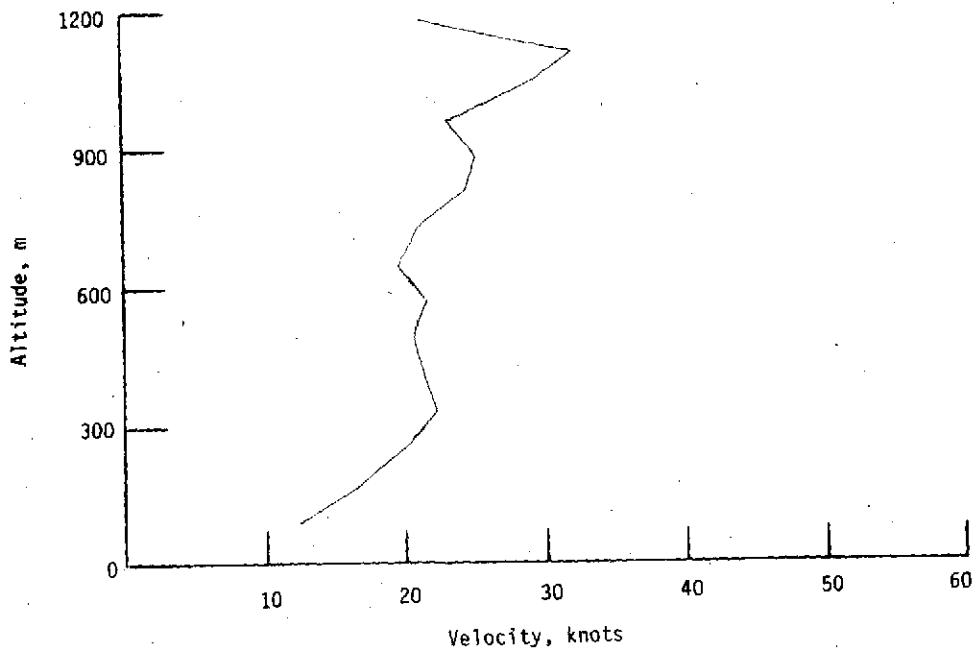
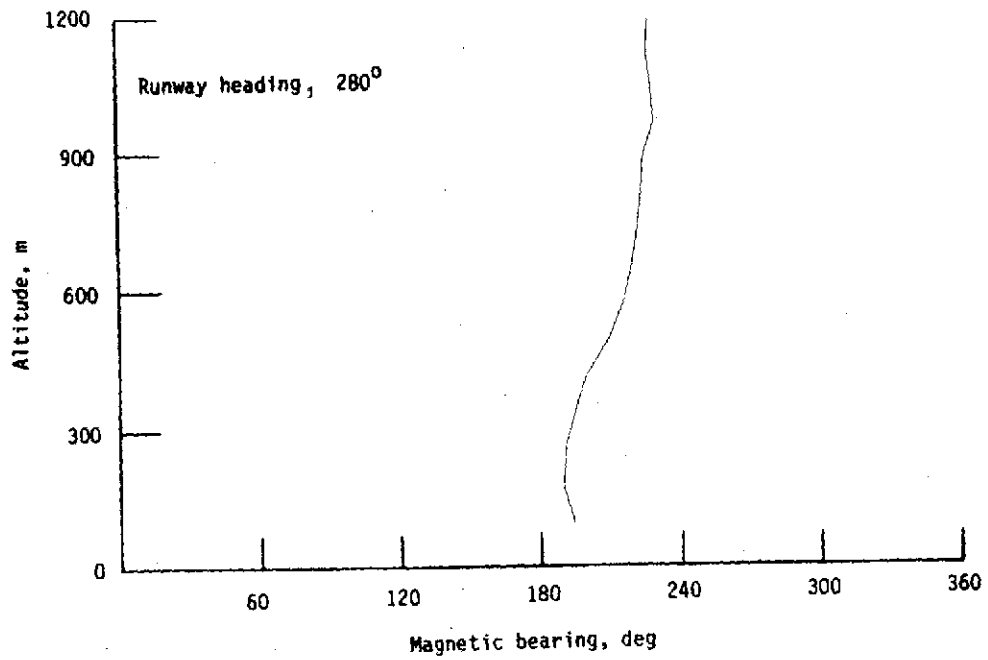

(e) Day 5. Data symbol Δ .

Figure 8.- Continued.

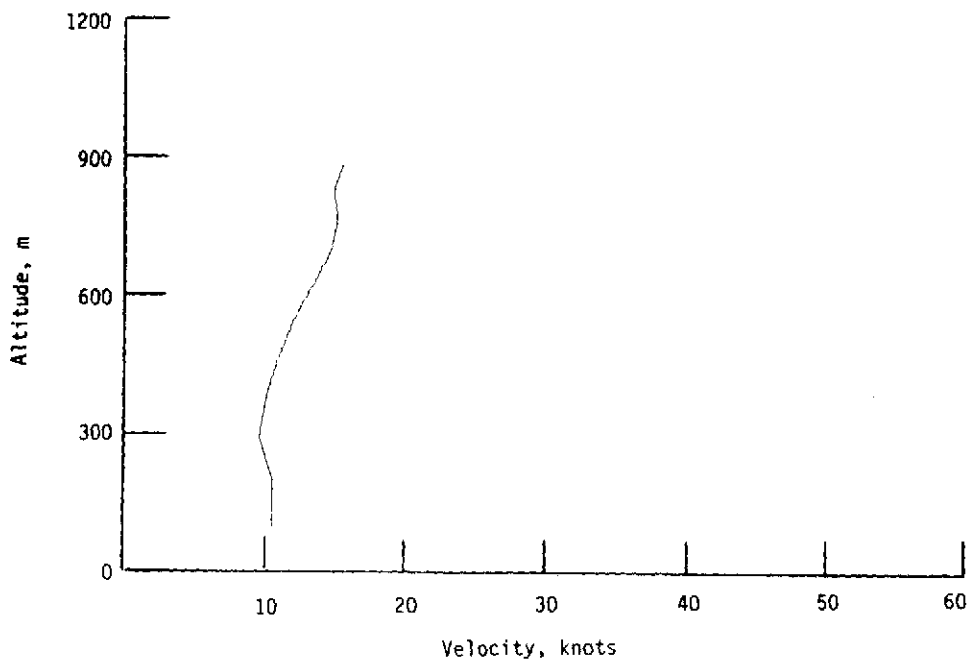
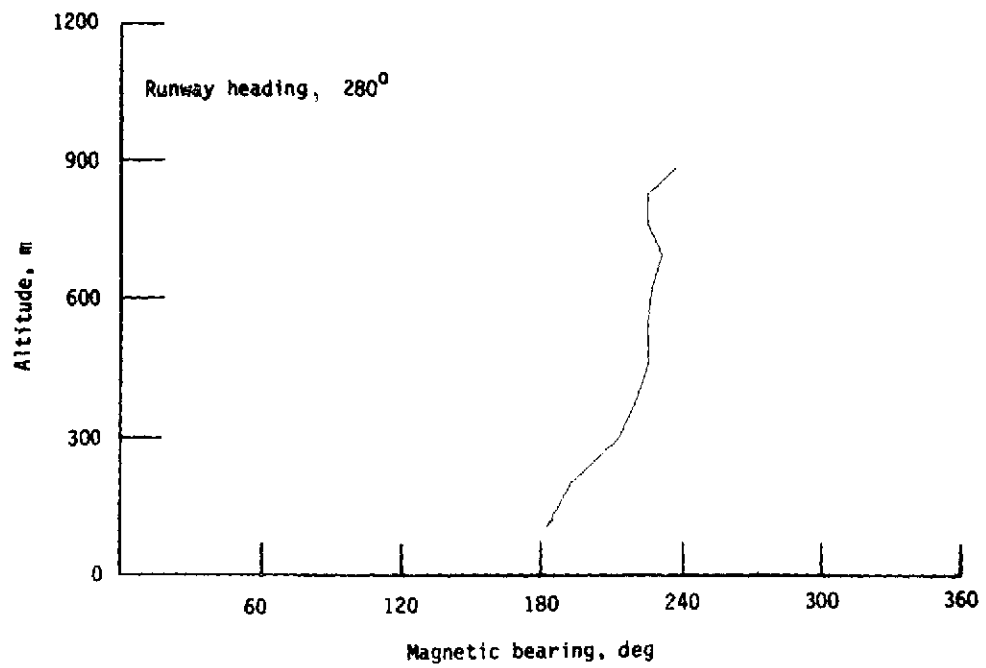

(f) Day 6. Data symbol Δ .

Figure 8.- Continued.

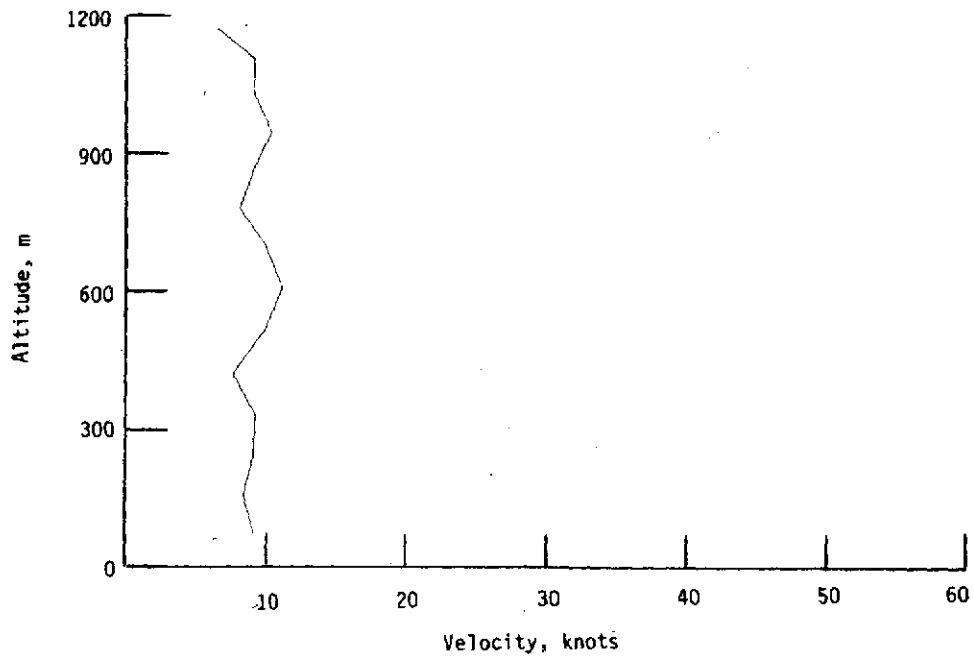
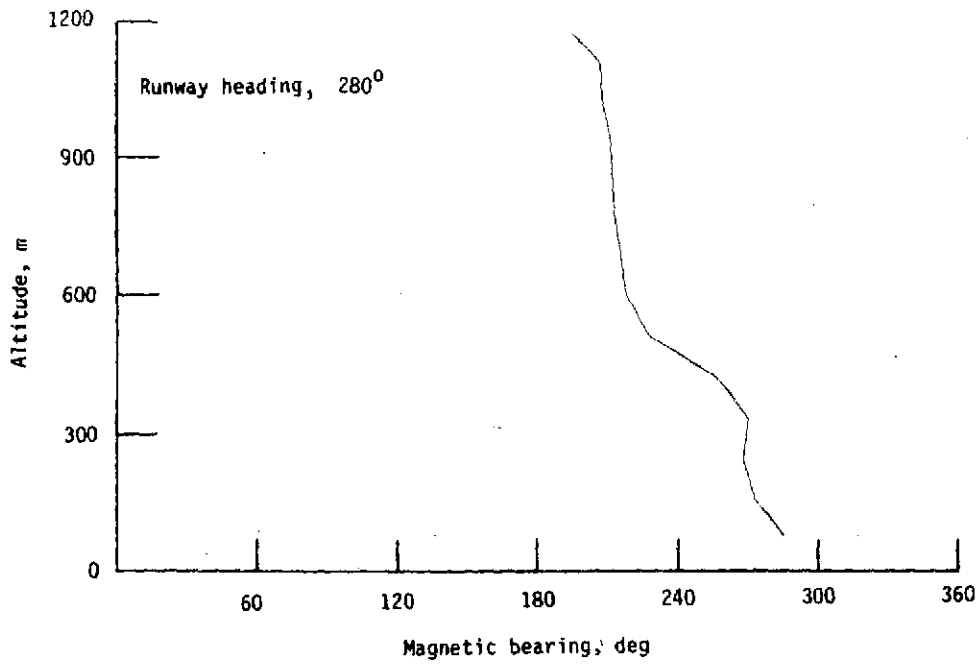

(g) Day 7. Data symbol \square .

Figure 8.- Concluded.

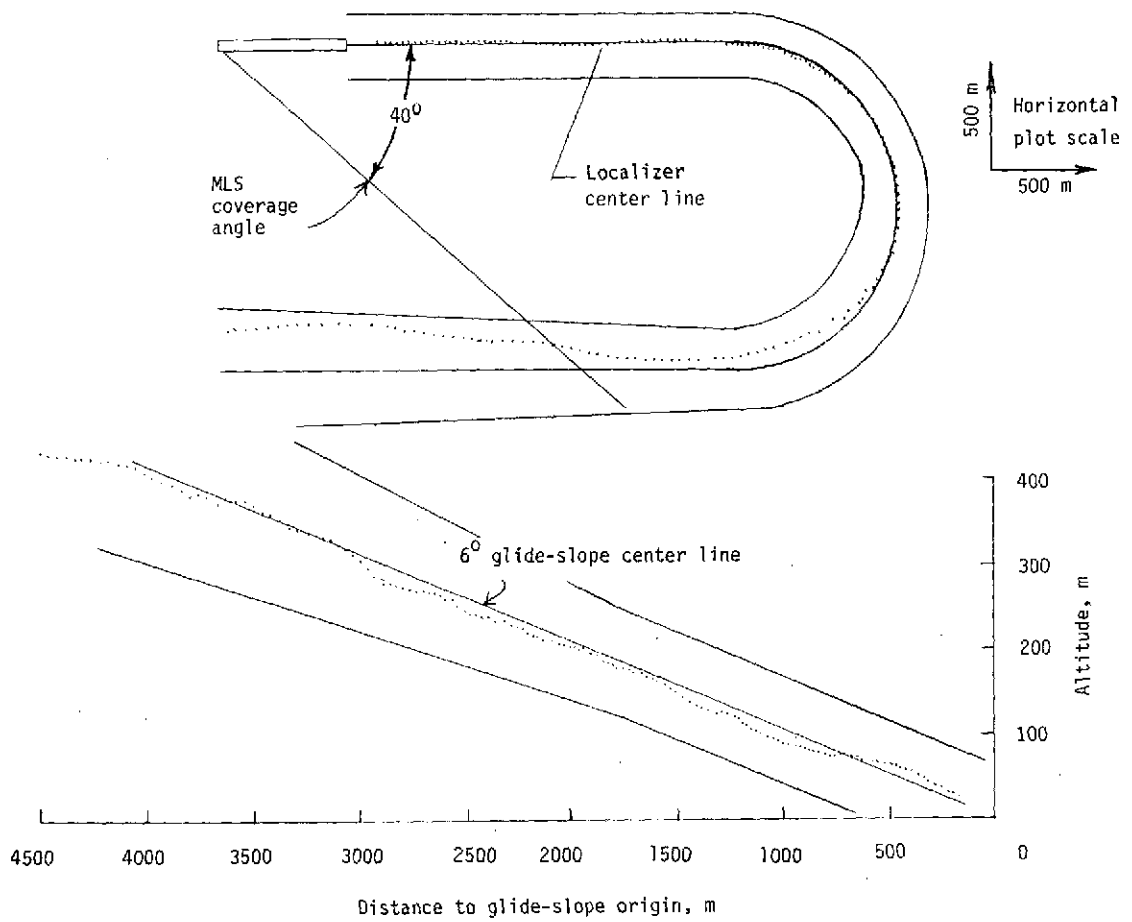

(a) Radar plots.

Figure 9.- Typical curved approach path results.

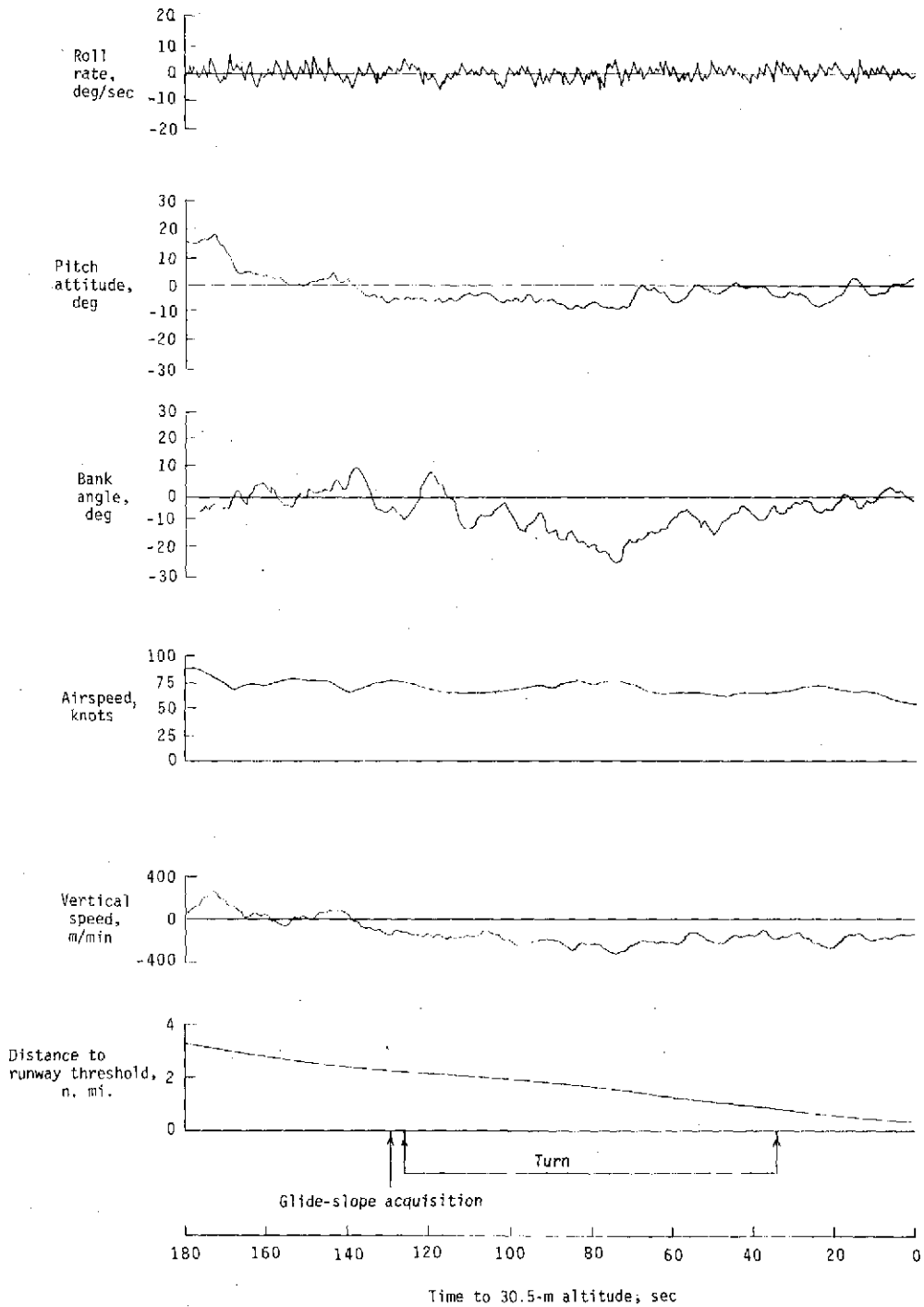

(b) Time histories of flight conditions.

Figure 9.- Continued.

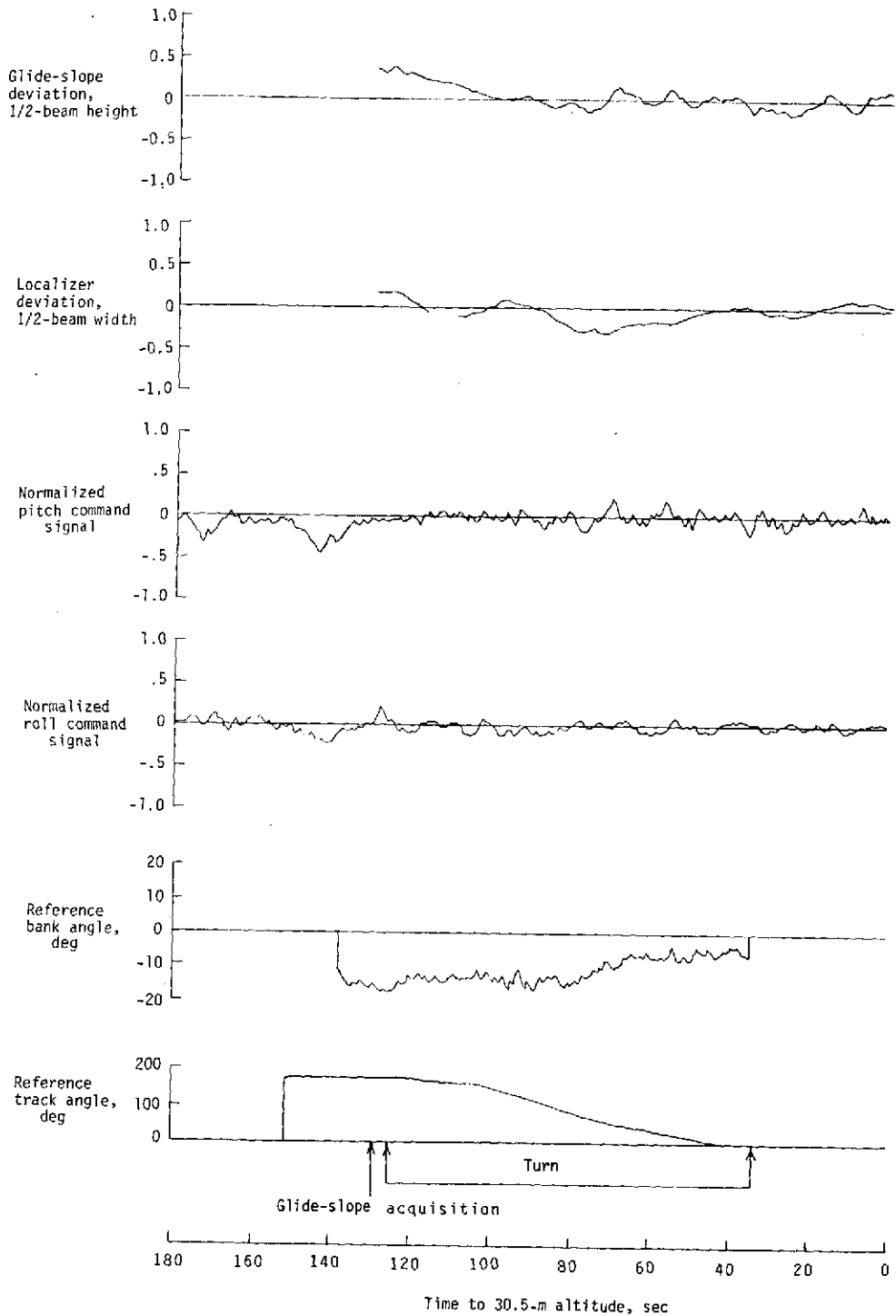

(c) Time histories of flight director inputs and commands and glide-slope and localizer deviations.

Figure 9.- Concluded.

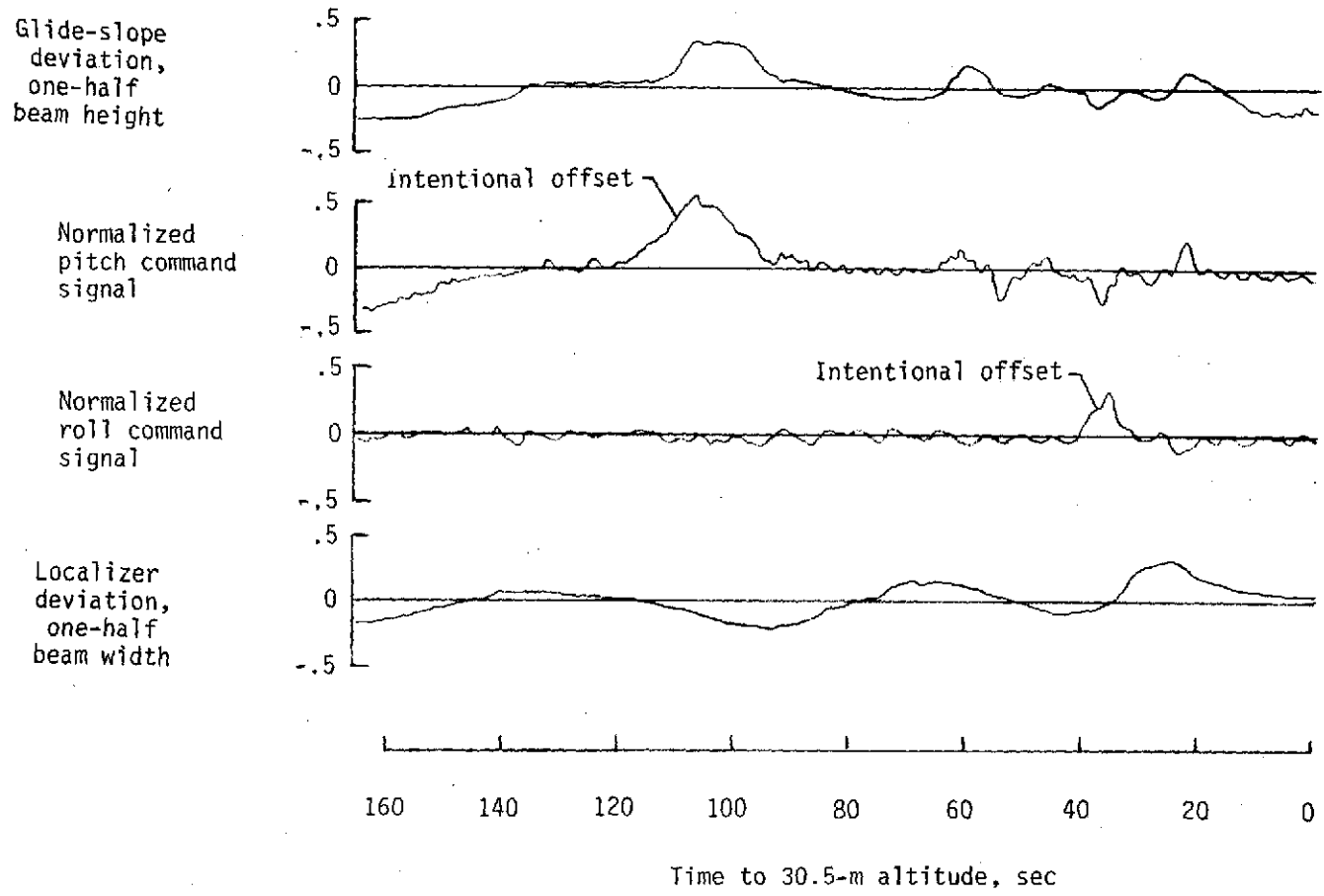

Figure 10.- Time histories of flight director commands and glide-slope and localizer deviations in a straight approach.

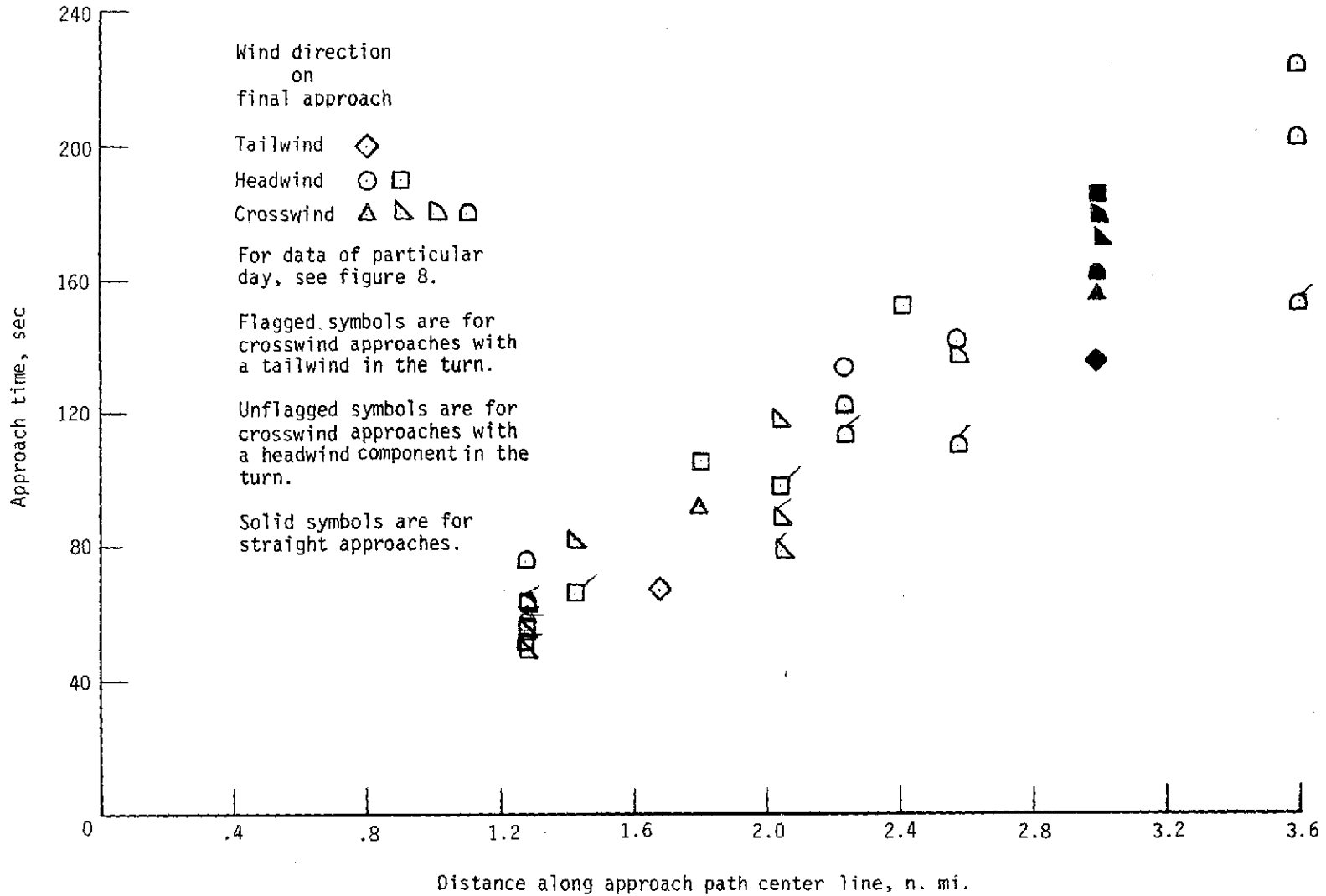

Figure 11.- Approach time from turn entry to 30.5-m (100-ft) altitude for various wind conditions and approach patterns. Target airspeed, 75 knots; 6° glide slope.

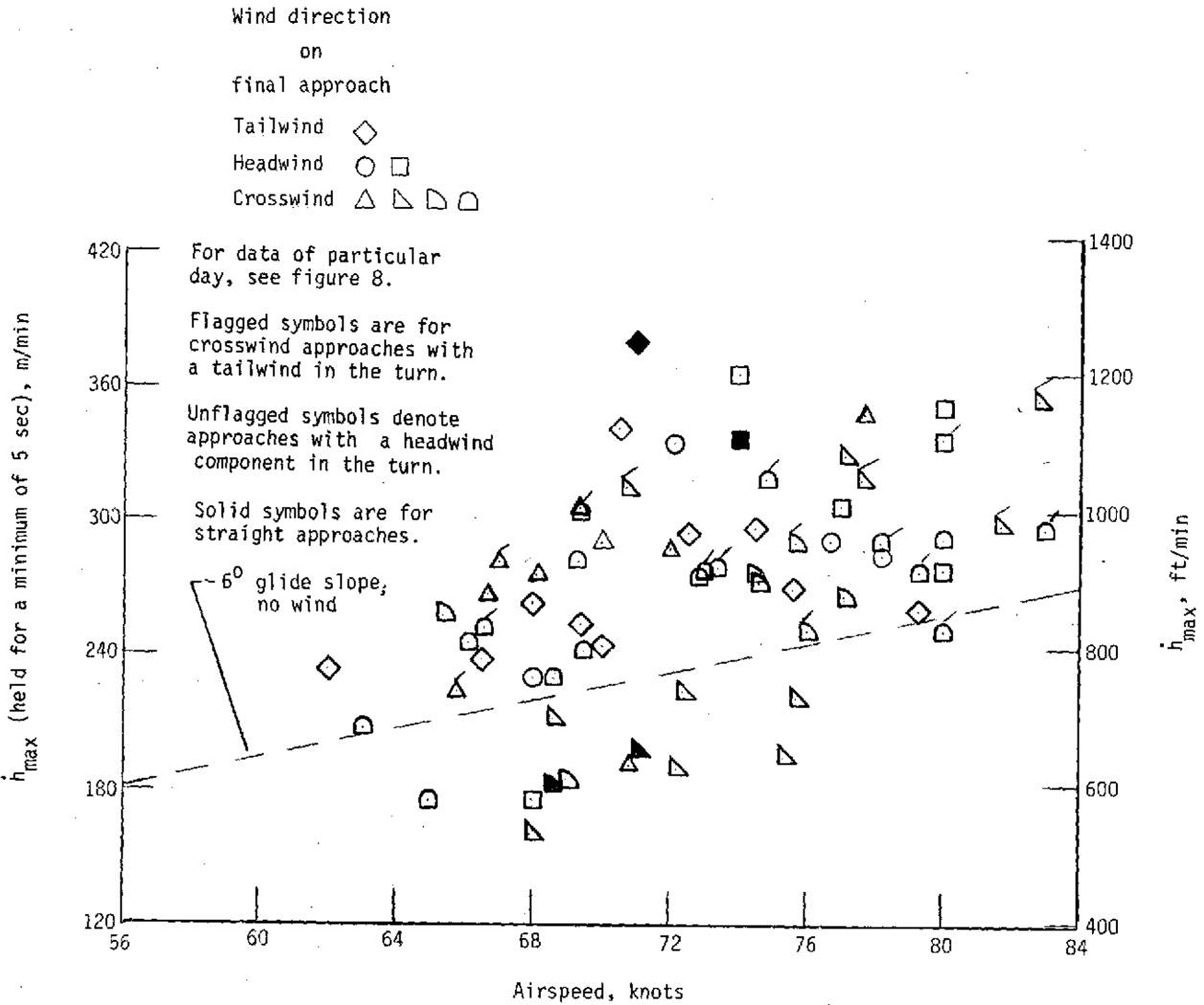

Figure 12.- Maximum descent rates held for a minimum of 5 seconds for various wind conditions and approach patterns. Target airspeed, 75 knots; 6° glide slope.

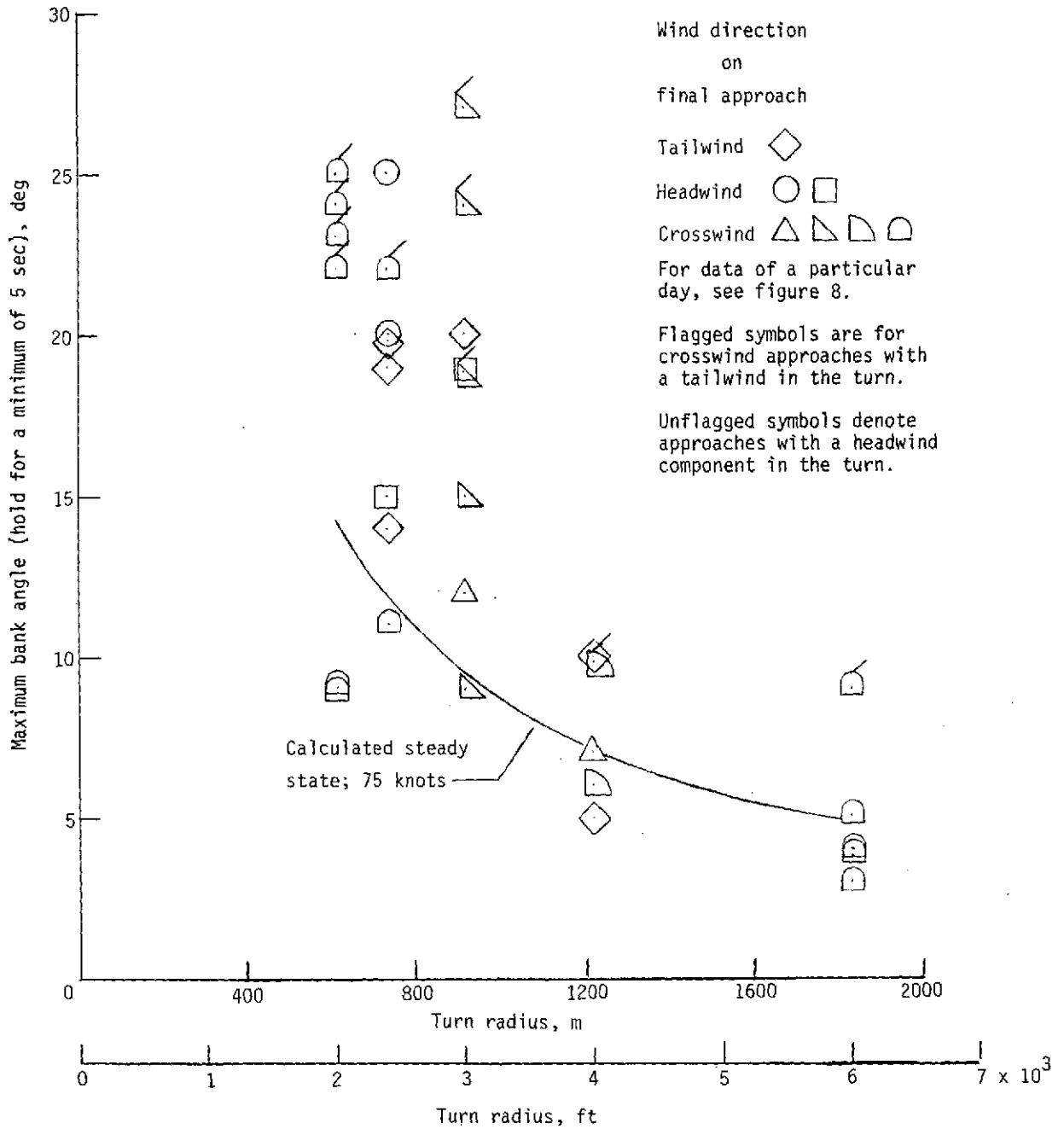

Figure 13.- Maximum bank angles held for a minimum of 5 seconds for various wind conditions and approach pattern. Target airspeed, 75 knots.

Wind direction on final approach

Tailwind \diamond
 Headwind \circ \square
 Crosswind \triangle ∇ \triangleleft \triangleright

For data of particular day, see figure 8.

Flagged symbols are for crosswind approaches with a tailwind in the turn.

Unflagged symbols denote approaches with a headwind component in the turn.

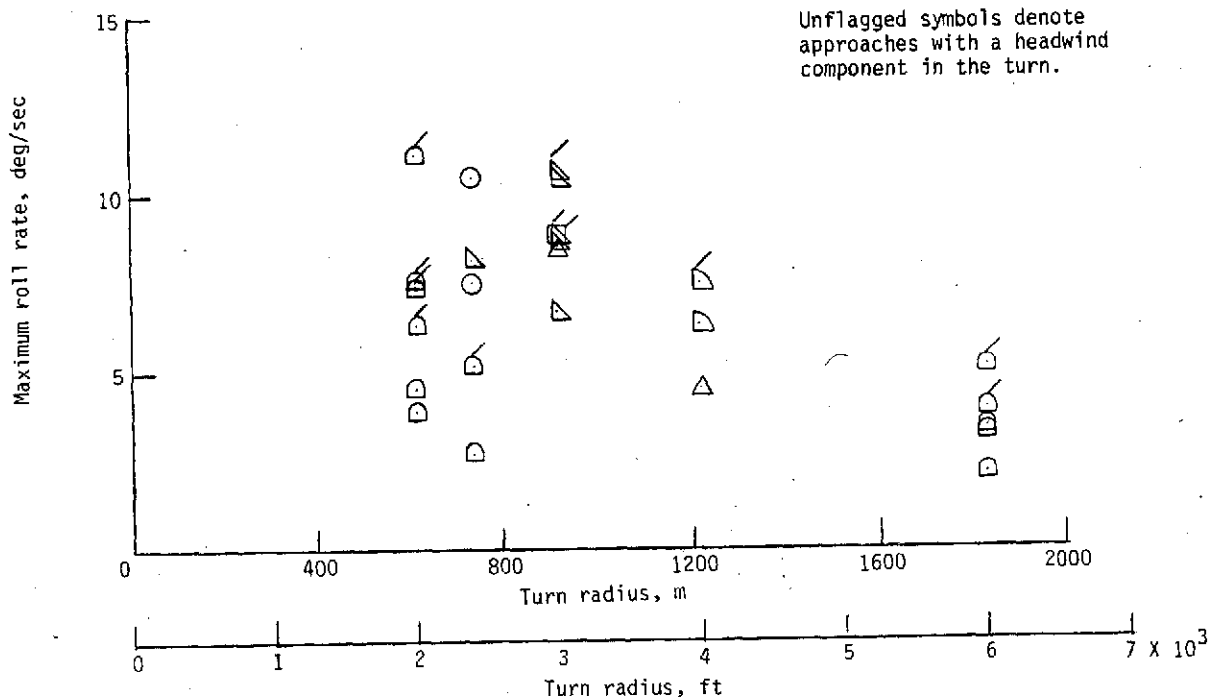

Figure 14.- Maximum roll rates for various wind conditions and approach patterns. Target airspeed, 75 knots.

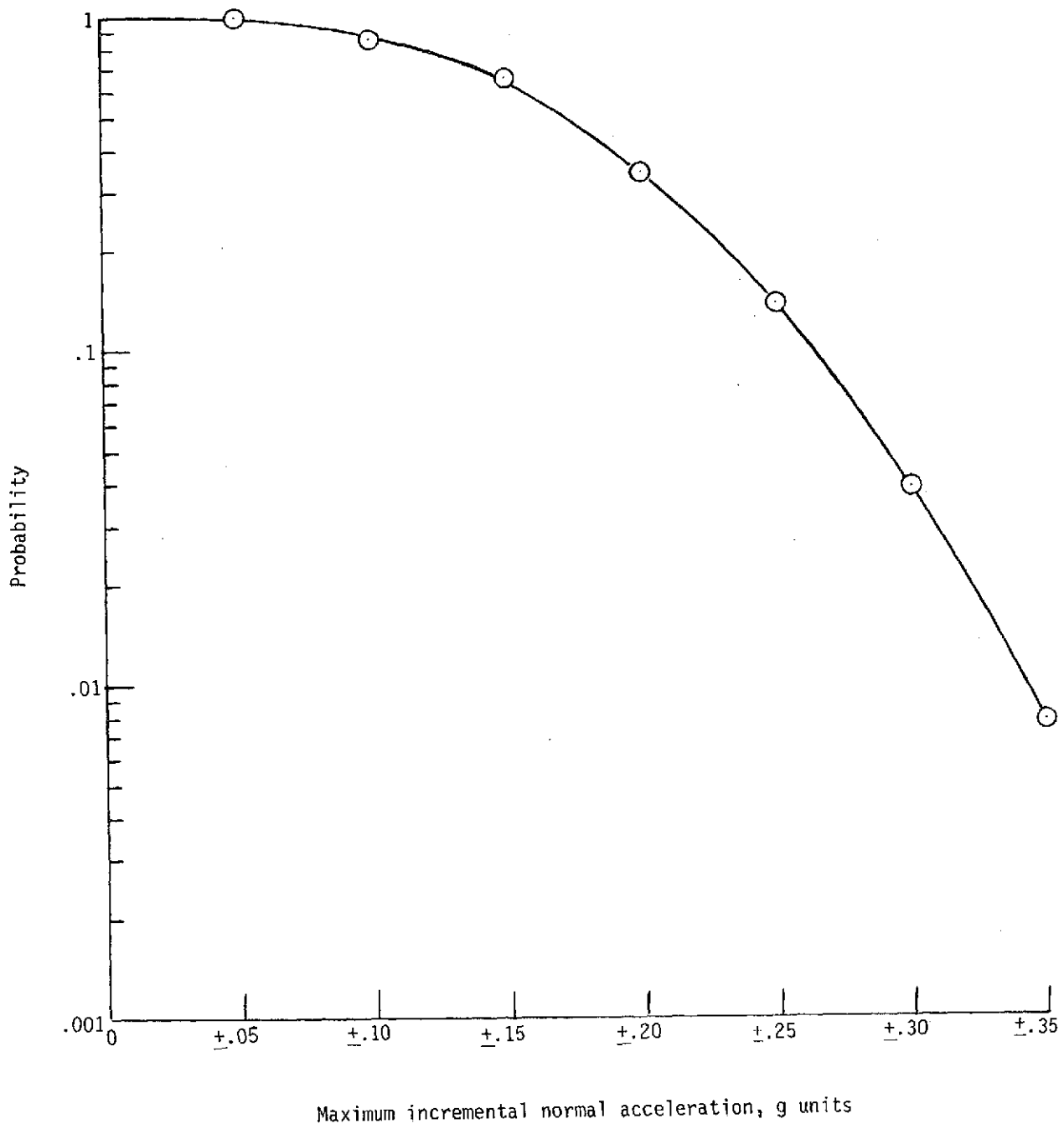
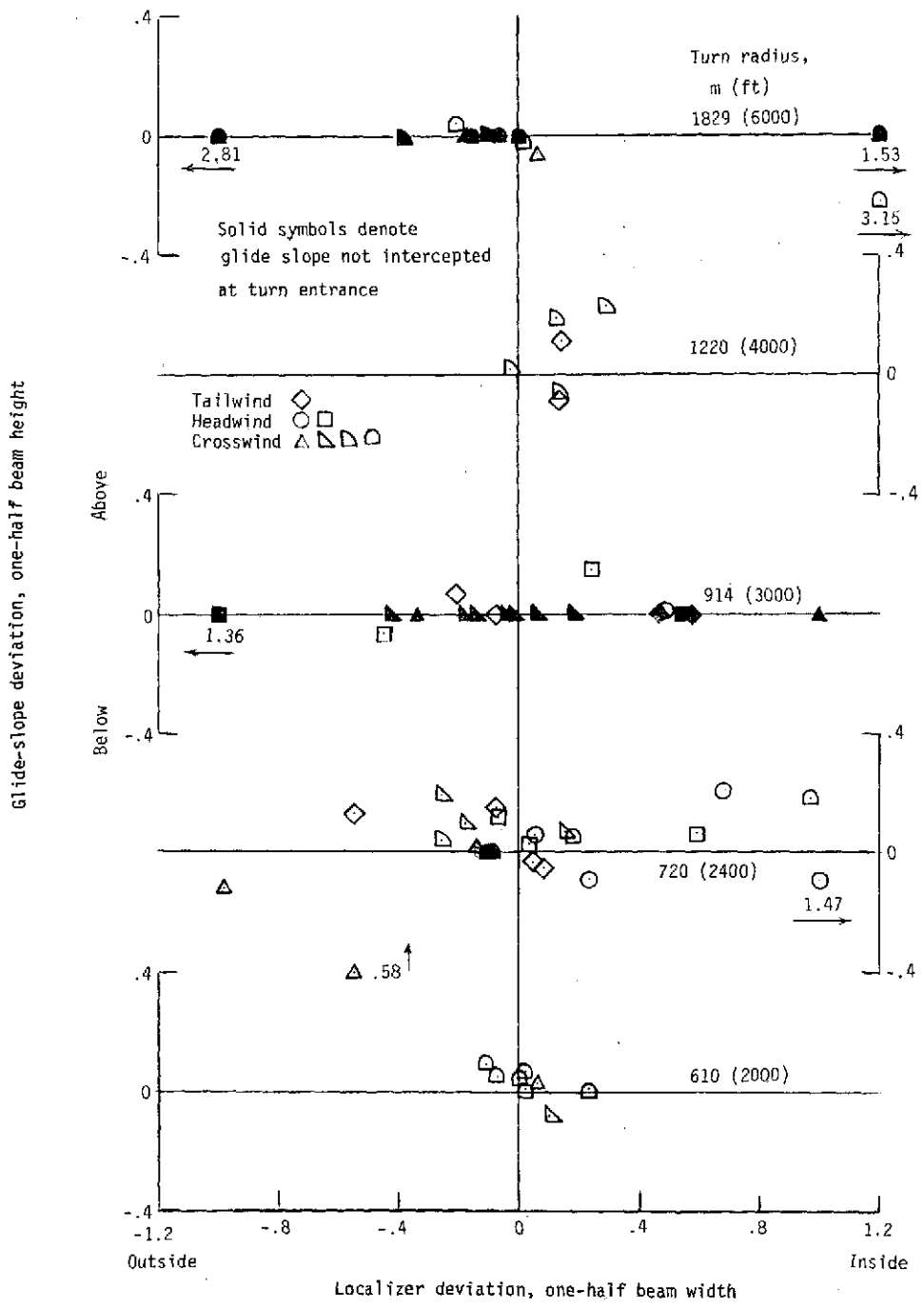
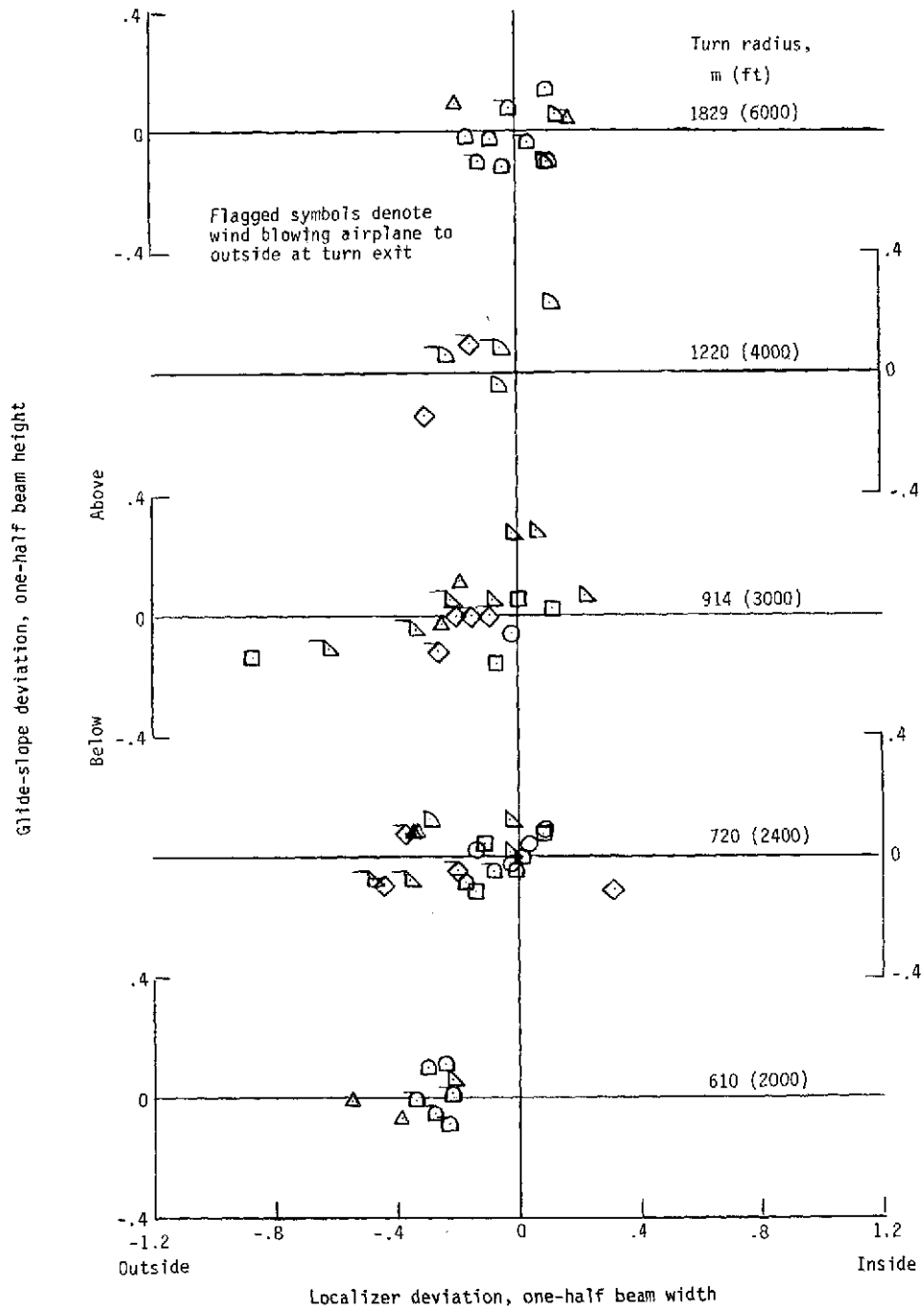

Figure 15.- Probability distribution of maximum incremental normal acceleration in curved descending approaches. Turn radius 1220 m (4000 ft), or less, and final approach distance 914 m (3000 ft), or less; 6° glide slope, 90°, 135°, and 180° turns. Wind velocities from 5 to 23 knots.



(a) Turn entrance.

Figure 16.- Localizer and glide-slope deviations at turn entrance and exit.



(b) Turn exit.

Figure 16.- Concluded.